

Department of Civil Engineering  
University of Alberta  
Edmonton



Structural Engineering Report No. 152

# KBES FOR THE DESIGN OF REINFORCED CONCRETE COLUMNS

by  
ALEXANDER S. BEZZINA  
SIDNEY H. SIMMONDS

July 1987

Structural Engineering Report No. 152

KBES for the Design of  
Reinforced Concrete Columns

by

Alexander S. Bezzina

and

Sidney H. Simmonds

Department of Civil Engineering  
University of Alberta  
Edmonton, Alberta

July 1987

## Abstract

The reasoning process adopted by an expert engineer in structural design comprises two components, namely:

1. the formal mathematical reasoning where every decision step follows directly from the previous computed information, and
2. the intuitive reasoning where a number of assumptions based on the acquired knowledge are made in arriving at a plausible design solution.

Knowledge-based expert systems for the proportioning and detailing of individual structural members must incorporate both of these components.

A knowledge-based system, developed for the analysis and design of reinforced concrete columns either for use in an automated CAD or a stand-alone environment is presented. The engineering design knowledge required as represented by a network of production rules is described. The solution strategies and techniques used in coupling heuristic and numerical algorithms are discussed. Column designs produced by the system are shown to be comparable to those proportioned by experienced structural engineers.

## Acknowledgements

This report is based on the M.Sc. thesis entitled Knowledge-Based CAD for Reinforced Concrete by A.S. Bezzina undertaken under the supervision of Dr. S.H. Simmonds.

The authors wish to express their appreciation to Dr. J.G. MacGregor, Department of Civil Engineering and Dr. R.E. Elio, Department of Computing Science, for their useful comments and suggestions during the course of this study. The assistance and advice given by Mr. T. Casey and Mr. A. Dunbar on computer related problems are greatly appreciated. Particular thanks are also due to Miss E. Arnold for helping in the preparation and revision of the typescript.

Financial assistance was received from the Canadian Commonwealth Scholarship and Fellowship Plan and The Natural Sciences and Engineering Research Council of Canada. This assistance is gratefully acknowledge.

## Table of Contents

Chapter	Page
Abstract .....	i
Acknowledgements .....	iii
List of Tables .....	vii
List of Figures .....	viii
Notation .....	ix
1. INTRODUCTION .....	1
1.1 General .....	1
1.2 Scope .....	2
1.3 The Global Design Problem .....	3
1.4 Integrated CAD Environment for Structural Engineering Applications .....	5
1.5 Existing Work on Knowledge-Based CAD Systems for Structural Design .....	7
2. PROGRAMMING ENVIRONMENT .....	9
2.1 Expert Systems .....	9
2.2 Structure of an Expert System .....	11
2.2.1 The Knowledge Base .....	13
2.2.2 The Inference Mechanism .....	14
2.2.3 The Blackboard .....	17
2.3 Knowledge Engineering .....	17
2.4 Programming Languages and Shells .....	19
2.5 User-Machine Interface .....	21
2.6 Host Hardware .....	25
3. EXPERT PROGRAMMING FOR STRUCTURAL DESIGN .....	26
3.1 Introduction .....	26
3.2 Design Criteria .....	26
3.3 Control by the Designer .....	27

3.4	Design Philosophy .....	28
3.5	Incorporation of Codes .....	29
3.6	Modularity of CAD Systems .....	31
3.7	Solution Strategies .....	33
4.	ENGINEERING LOGIC USED IN <i>COLUMN</i> .....	37
4.1	Program Scope and Capabilities .....	37
4.2	General Design Strategy used in Developing <i>COLUMN</i> .....	41
4.3	Column Section Proportioning and Detailing .....	43
4.3.1	Selection of Initial Concrete Section .....	43
4.3.2	Selection of Longitudinal Reinforcement .....	48
4.4	Evaluation of Strength Capacity .....	54
4.4.1	Second Order Effects in Columns .....	54
4.4.2	Strength Capacity of Section .....	55
4.4.3	Biaxial Bending .....	63
5.	DESIGN EXAMPLES .....	69
5.1	Introduction .....	69
5.2	Example 1 - Tied Column Design .....	69
5.3	Example 2 - Circular Spiral Column .....	73
5.4	Example 3 - Biaxial Bending .....	77
5.5	Conclusions .....	86
6.	SUMMARY AND CONCLUSIONS .....	87
6.1	Summary .....	87
6.2	Conclusions .....	88
	REFERENCES .....	89
	APPENDIX A - DETAILED CALCULATIONS .....	94
A.1	Sign Convention and Nomenclature .....	94
A.2	Slenderness Effects in Braced Members .....	94

A.3	Moment Magnifier for Slender Braced Columns	....99
A.4	Slenderness Effects in Unbraced Columns	.....101
A.5	Moment Magnifier for Slender Unbraced Columns	.104
A.6	Moment Magnification for Different Loading Conditions	.....106
A.7	Evaluation of Moment of Inertia of Steel Reinforcement	.....107
	A.7.1 Bars in a Rectangular Array	.....107
	A.7.2 Bars in a Circular Array	.....112
A.8	Modification of Capacity Reduction Factor	....113
A.9	Evaluation of Longitudinal Splices	.....115
A.10	Lateral Reinforcement	.....119
<b>APPENDIX B - USER'S MANUAL</b>		.....121
B.1	Introduction	.....121
B.2	General Comments	.....121
B.3	Operational Modes	.....123
B.4	Data Input	.....123
B.5	Running the Program	.....130
B.6	Sample Run	.....131
B.7	Diagnostic Messages	.....132
B.8	Summary of Flags Used in Program	.....136

## List of Tables

Table	Page
4.1 Number of Bars in Each Column Face .....	52
4.2 Accuracy of the Equivalent Eccentricity Method .....	68



## List of Figures

Figure	Page
1.1 The Design Process .....	4
1.2 Architecture of an Integrated Structural Engineering CAD System .....	6
2.1 Structure of an Expert System .....	12
3.1 Correlation between Module Classification .....	34
4.1 Sections Considered by <i>COLUMN</i> .....	39
4.2 General Design Strategy Used in <i>COLUMN</i> .....	44
4.3 Rule Network for Selection of R for Columns Subjected to Biaxial Bending .....	47
4.4 Production Rules for Selecting Reinforcing Pattern .....	50
4.5 Strength Capacity of Uniaxially Loaded Column .....	57
4.6 Interval Halving Technique for Location of NA .....	59
4.7 Compression Zone for Circular Section ( $a \leq h/2$ ) .....	61
4.8 Compression Zone for Circular Section ( $a > h/2$ ) .....	61
4.9 Evaluation of Strength Capacity .....	64
A.1 Moment Sign Convention .....	95
A.2 Sign Convention and Nomenclature .....	96
A.3 Reinforcement in a Rectangular Array .....	111
A.4 Reinforcement in a Circular Array .....	111
A.5 Variation of $\phi$ .....	114
A.6 Longitudinal Splices .....	116

## Notation

$a$	= depth of equivalent rectangular stress block
$A_b$	= area of the reinforcing bars
$A_c$	= area of concrete in compression
$A_g$	= gross area of the section
$A_g^o$	= initial trial gross area of section
$A_{st}$	= total area of reinforcing bars
$b$	= width of compression face of member
$b_1$	= column dimension required to accommodate reinforcement with bearing splices
$b_2$	= column dimension required to accommodate reinforcement with normal lap splices
$b_3$	= column dimension required to accommodate reinforcement with tangential lap splices
$c$	= distance from extreme compression fibre to neutral axis
$c_x$	= column dimension in the x-direction
$c_y$	= column dimension in the y-direction
$C_m$	= a factor relating actual moment diagram to an equivalent uniform moment diagram
$d_b$	= the nominal bar diameter of longitudinal reinforcing bars
$d_c$	= clear thickness of concrete cover
$d_s$	= bar diameter of lateral reinforcement
$D_c$	= diameter of concrete core
$e$	= eccentricity of the applied axial load measured from the centroid
$e_o$	= equivalent eccentricity of the applied load
$E_c$	= modulus of elasticity of concrete
$E_s$	= modulus of elasticity of reinforcement

- $EI$  = flexural stiffness of compression member  
 $f'_c$  = specified compressive strength of concrete  
 $f_{sy}$  = specified yield strength of spiral reinforcement  
 $f_y$  = specified yield strength of longitudinal reinforcement  
 $h$  = overall thickness of member  
 $I_g$  = moment of inertia of gross concrete section about centroidal axis, neglecting reinforcement  
 $I_{se}$  = moment of inertia of reinforcement about centroidal axis of member cross section  
 $k$  = effective length factor for compression members  
 $l_u$  = unsupported length of compression member  
 $M_c$  = magnified factored moment to be used for design of compression member  
 $M_{ns}$  = factored end moment on a compression member due to loads that result in no appreciable lateral deflection, calculated by conventional elastic frame analysis  
 $M_r$  = factored moment resistance  
 $M_s, M_{2s}$  = factored end moment on a compression member due to loads which result in appreciable lateral deflection, calculated by conventional elastic analysis  
 $M_1, M_{1b}$  = value of smaller factored end moment on compression member and associated with the same loading case as  $M_2$ , positive if member is bent in single curvature, negative if bent in double curvature  
 $M_2, M_{2b}$  = value of larger factored end moment on compression member, always positive  
 $N_b$  = total number of bars  
 $N_{col}$  = number of columns in the storey  
 $N_x$  = number of bars on the x-face only, including corner bars  
 $N_y$  = number of bars on the y-face only, not including corner bars

- $P_b$  = nominal axial load strength at balanced strain conditions  
 $P_c$  = critical load  
 $P_f, P_u$  = factored axial load  
 $P_r, P_n$  = axial load resistance  
 $r$  = radius of gyration of cross section of a compression member  
 $R$  = column aspect ratio ( $c_x/c_y$ )  
 $S$  = pitch of spiral  
 $S_b$  = clear bar spacing  
 $x_b$  = distance of bar from centroidal axis  
 $\bar{y}$  = the distance from centroid of area of concrete in compression to the centroid of the section  
 $a$  = factor used in determining equivalent eccentricity  
 $\beta_1$  = ratio of depth of rectangular compression block to depth to the neutral axis  
 $\beta_d$  = absolute value of ratio of maximum factored dead load moment to maximum factored total load moment, always positive  
 $\gamma$  = the ratio of centre to centre distance between outermost reinforcing bars (measured perpendicular to the axis of bending) to the overall depth of the column  $h$   
 $\delta$  = moment magnification factor for columns  
 $\delta_b$  = moment magnification factor to reflect the effects of member curvature between ends of compression members  
 $\delta_s M_s$  = the factored end moment at the end of the column due to loads causing appreciable lateral displacement, calculated by a conventional elastic frame analysis and increased for second-order effects of vertical load acting on a structure in a displaced lateral configuration  
 $\rho_g$  = maximum ratio of reinforcement  
 $\rho_s$  = ratio of spiral reinforcement

- $\phi$  = strength reduction factor
- $\phi_c$  = resistance factor for concrete
- $\phi_m$  = member resistance factor
- $\phi_s$  = resistance factor for reinforcing bars

**Subscripts**

- n = number of bars
- x = about the x-axis
- y = about the y-axis

## 1. INTRODUCTION

### 1.1 General

To date, most computer programs used for the analysis and design of reinforced concrete structural elements comprise of a set of linked tractable algorithms based on well defined mathematical sequential steps. These steps represent hard rules of a well established design procedure: one that is deterministic in nature and is often open to only one specific interpretation. While such programs have proved useful to facilitate and speed up the tedious mathematical computations involved in design they lack the most important aspect of the design procedure: the intuitive process of decision making. This restricts their use in a structural engineering CAD (computer-aided design) environment.

The engineering logic and decisions inherent in the design procedures are subjective and implicit in nature and are dependent on the acquired knowledge and experience of the structural engineer. The translation of the engineer's judgement and design concepts into computer programming is an essential component for building KBES (knowledge-based expert systems).

## 1.2 Scope

This thesis discusses the problems that must be solved in the development of a knowledge-based CAD system for the analysis, proportioning and detailing of structural elements, and in particular reinforced concrete elements. The principal objective is to examine the techniques and tools used in building CAD programs containing both numerical algorithmic and knowledge-based subprograms that are capable of being used independently or in the form of an integrated CAD system. This task is the first step in attaining the final goal of producing a comprehensive integrated CAD environment for multistorey reinforced concrete frame structures.

To illustrate this concept, *COLUMN*, a program for the design of reinforced concrete columns is presented. *COLUMN* constitutes only a part of a global structural engineering CAD system, however, most of the techniques and tools used in building knowledge-based expert systems are demonstrated. Emphasis is given to the design philosophy and the methodologies of knowledge engineering applied.

Since the field of expert systems and the corresponding field of knowledge engineering are relatively new in concept and still in the experimental stage, a special introduction to the subject is necessary. Hence, a general overview of the definitions, concepts, techniques and tools pertaining to the field of knowledge-based programming is examined in Chapter 2.

### 1.3 The Global Design Problem

The structural engineering design of buildings, from the conceptual stage to the construction phase, is a complex process which entails a number of distinct but interrelated tasks:

1. Conception of the project.
2. Synthesis of the preliminary design which involves generating or creating alternative builtform layouts.
3. Structural analysis of the frame considering various loading patterns and assuming preliminary section dimensions and material properties.
4. Proportioning and detailing of the structural members including foundations, columns, beams and slabs for safety and serviceability requirements.
5. Review and revision of the design.
6. Construction of the building.

This design process also summarized in Fig. 1.1, can be viewed as a constraint satisfaction problem. In such a cyclic and iterative process, adjustments and modifications are made until a feasible design that is consistent with the project's requirements is found.

The structural engineer is involved throughout the complete design process, however, it is his task alone to select and proportion in detail an appropriate type or form of structure. These design phases correspond to tasks (2) to (5) above.



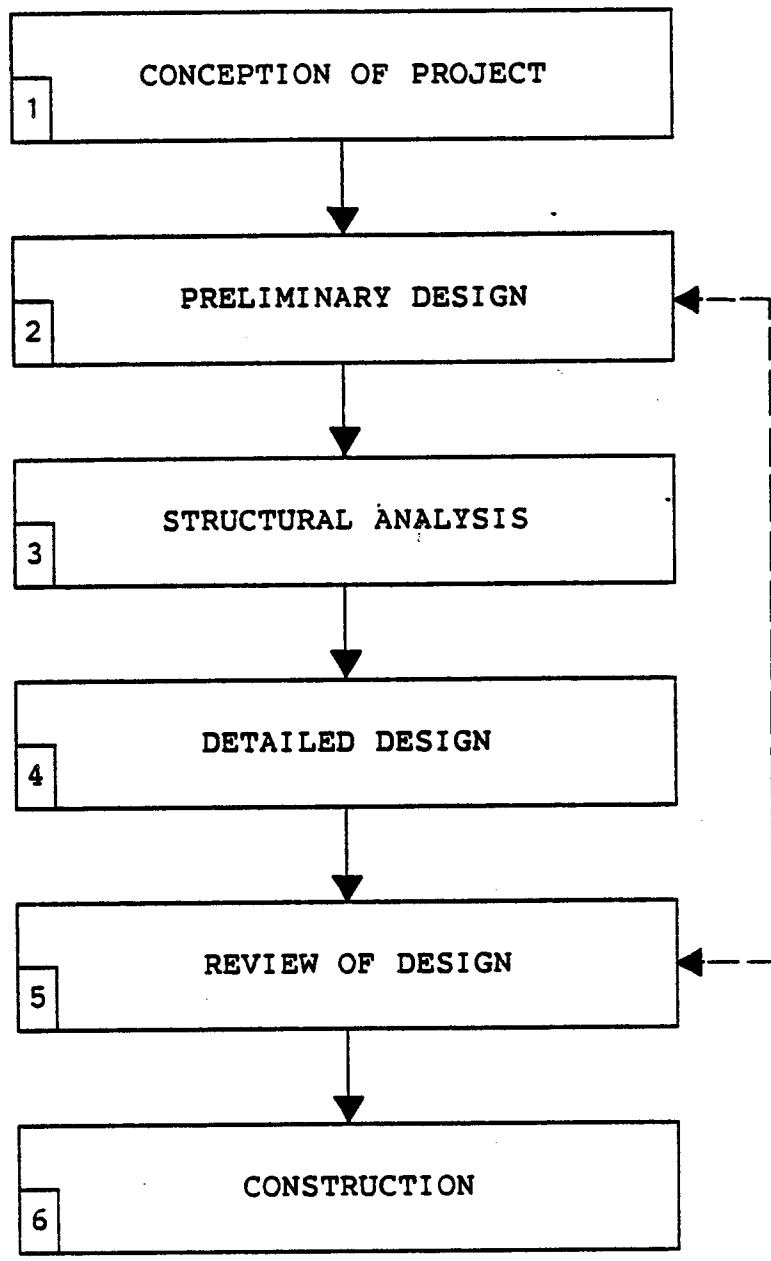

Figure 1.1 The Design Process

The design process is becoming increasingly more complex. The computerized approach to design, known as computer-aided design (CAD), has proven to be a valuable tool in automating these design procedures.

#### **1.4 Integrated CAD Environment for Structural Engineering Applications**

A system that is capable of assisting the engineer in design work ideally should contain a network of modules that are coordinated and integrated into a global structural engineering CAD environment (Fig. 1.2). Essentially, a prototype of such a system comprises four basic components, namely:

1. A structural analysis algorithmic module.
2. A set of knowledge-based and algorithmic modules for the proportioning and detailing of the individual structural elements.
3. A main design control knowledge-based system that links modules in (1) and (2), evaluates all information and results, and decides on an appropriate design route based on the built-in knowledge base and inference mechanism.
4. A database which integrates all the other modules and is considered to be the core of the system. Information and data is interfaced between the modules via this database or workfile. The database could be separate from or part of the design control module (Rehak et al., 1984).

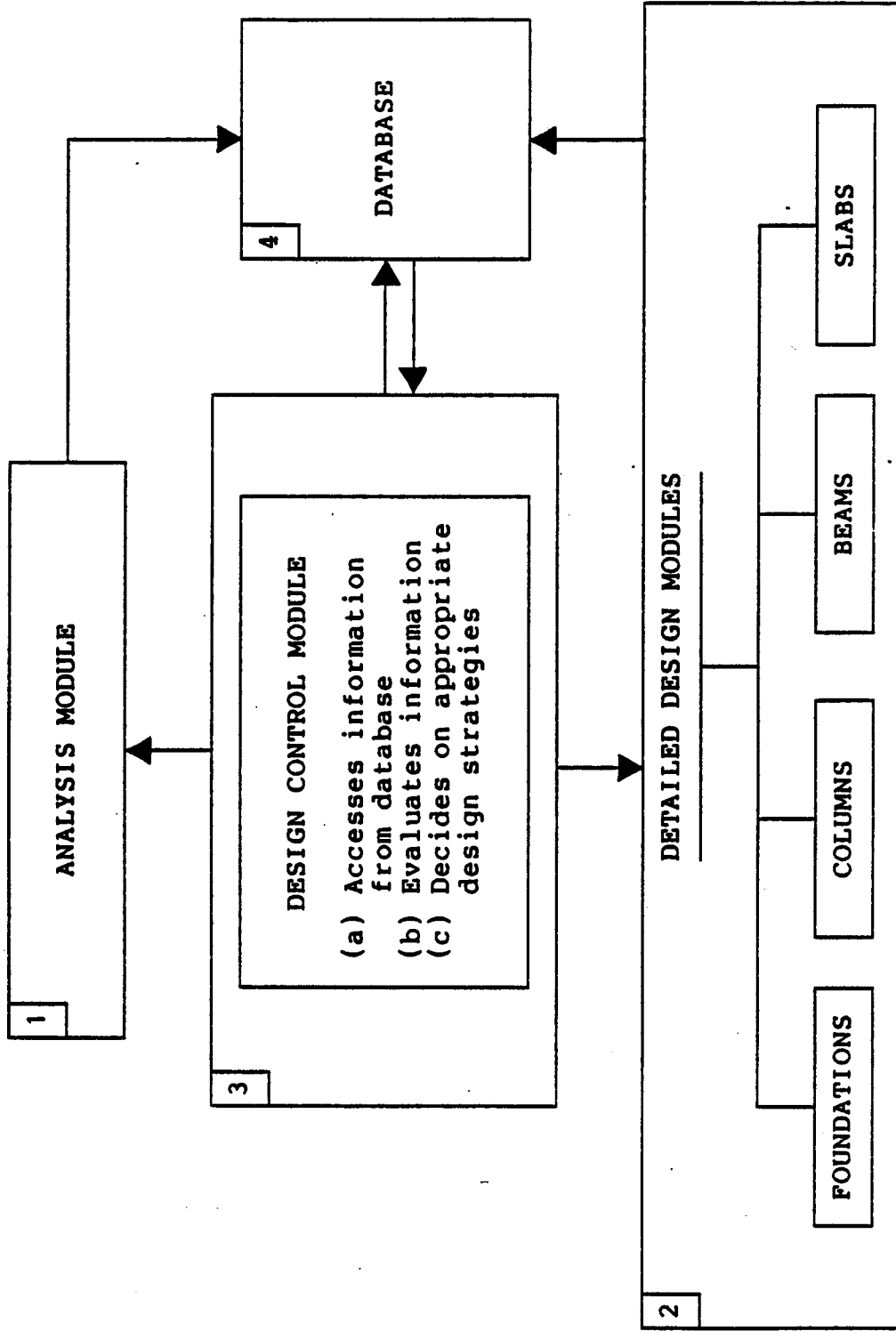

Figure 1.2 Architecture of an Integrated Structural Engineering CAD System

This global design framework also forms the basis for the development of any part of the system. Consequently, the overall philosophy and concepts that are applicable to the integrated system should be accounted for and implemented in the development of the separate modules.

### **1.5 Existing Work on Knowledge-Based CAD Systems for Structural Design**

Owing to the degree of complexity inherent in the design process, CAD systems that incorporate all aspects of design are still in a conceptual stage. Rehak et al. (1984) proposed a conceptual architecture for a knowledge-based environment for structural engineering applications. Various system structures representing different phases of the design process and their linkage into a network environment are presented.

Knowledge-based CAD systems related to structural design which are still in the development stage, including *SACON*, *SPERIL*, *SICAD* and *HI-RISE* (Maher and Fenves, 1984), are discussed by Adeli (1985) and Rehak et al. (1984).

*HI-RISE* for example, is an expert system that assists engineers in deciding upon a preliminary design of a structural system for rectangular high-rise buildings. The system performs an approximate analysis and sizing of members, evaluates various design possibilities, and selects the best structural framing system.

Little work has been done on knowledge-based systems for the design and detailing of the individual reinforced concrete members that compose the structural system. Existing computer programs, that claim to design members such as those by Halvorsen (1983), Ehsani (1986), Davister (1986), Ross and Yen (1986), and Balaguru (1987) essentially 'check' to confirm whether a section is satisfactory for a specified loading condition or determine the load capacity of the entered section. Consequently, for each of these programs, the section dimensions and data regarding reinforcement have to be entered by the user.

In contrast, *COLUMN* incorporates knowledge-based and design-logical subroutines that simulate the engineering rules of thumb and logic of an expert structural engineer. The inclusion of such expertise enables the program to select feasible column sections that are consistent with the particular loading configuration and constructibility constraints. The manner in which this is accomplished is described in the following chapters.

## 2. PROGRAMMING ENVIRONMENT

### 2.1 Expert Systems

Recent research and developments in the field of artificial intelligence (AI) has led to the evolution of new computer systems known as knowledge-based expert systems (KBES). Interactive computer programs that play the role of a human intelligent consultant are also referred to as intelligent knowledge-based systems (IKBS).

Expert systems are computer programs that simulate and embody domain specific knowledge which is applied skillfully in solving problems that are complex in nature and often require expert decision making. A definition of an expert system is given by Feigenbaum (1981):

"An expert system is an intelligent program that uses knowledge and inference procedures to solve problems that are difficult enough to require significant human expertise for their solution. The knowledge necessary to perform at such a level, plus the inference procedure used can be thought of as a model of the expertise of the best practitioners in the field."

The fundamental aspect in expert systems is the representation of a body of knowledge and the ability to use it intelligently. Hayes-Roth et al. (1983) distinguish between two types of knowledge: public and experiential.

Public knowledge in structural engineering includes well-defined theories and facts that are usually well documented. For example, the fundamental principles of structural mechanics such as equilibrium fall in this area. Code specifications are frequently based on experimental research and are therefore empirical in nature. However, for design purposes, when these quasi-empirical methods are codified into standards, they become established information and henceforth constitute a part of the public design knowledge to the engineer. This erudition can be translated easily into computer programming in the form of conventional algorithms incorporating a set of procedures based on a number of domain dependent rules.

Experiential knowledge comprises rules of thumb, intuitive design concepts, and sound engineering judgement attained through experience in the specific field; it is the knowledge that the expert engineers possess that is not commonly available in published literature or codes. For example, in the design of reinforced concrete structures, rules or recommendations regarding the selection of the dimensions of a structural element or reinforcement pattern are not specified by codes, although certain limitations might be stipulated. Such a decision is designer controlled and depends on his acquired expertise.

For the purposes of building KBES, knowledge is subdivided into chunks of knowledge which can be represented by separate rules called heuristics. Heuristics provide the

direction in solving problems that lack a formal mathematical reasoning or relationship. They enable "expert systems to make educated guesses, recognize promising approaches and execute an ordered search" (Hayes-Roth, 1983) thus aiding to establish a design solution strategy.

Another form of knowledge that enhances the versatility and effectiveness of the KBES is known as metaknowledge. Metaknowledge can be thought of as a higher strategic knowledge about the type of knowledge that is applicable to the particular circumstances.

## 2.2 Structure of an Expert System

In its simplest idealized form, an expert system consists of three main components (Fig. 2.1):

1. A knowledge base, which includes expert knowledge about the domain.
2. An inference mechanism or engine (also referred to as control system, reasoning mechanism or rule interpreter) which selects, interprets and applies the appropriate knowledge.
3. A blackboard in which intermediate results and observations are stored temporarily. This is a working memory in which a situation model is set up and updated.

In addition, an expert system includes a user's interface which incorporates a language processor that interprets user's input and generates output information.



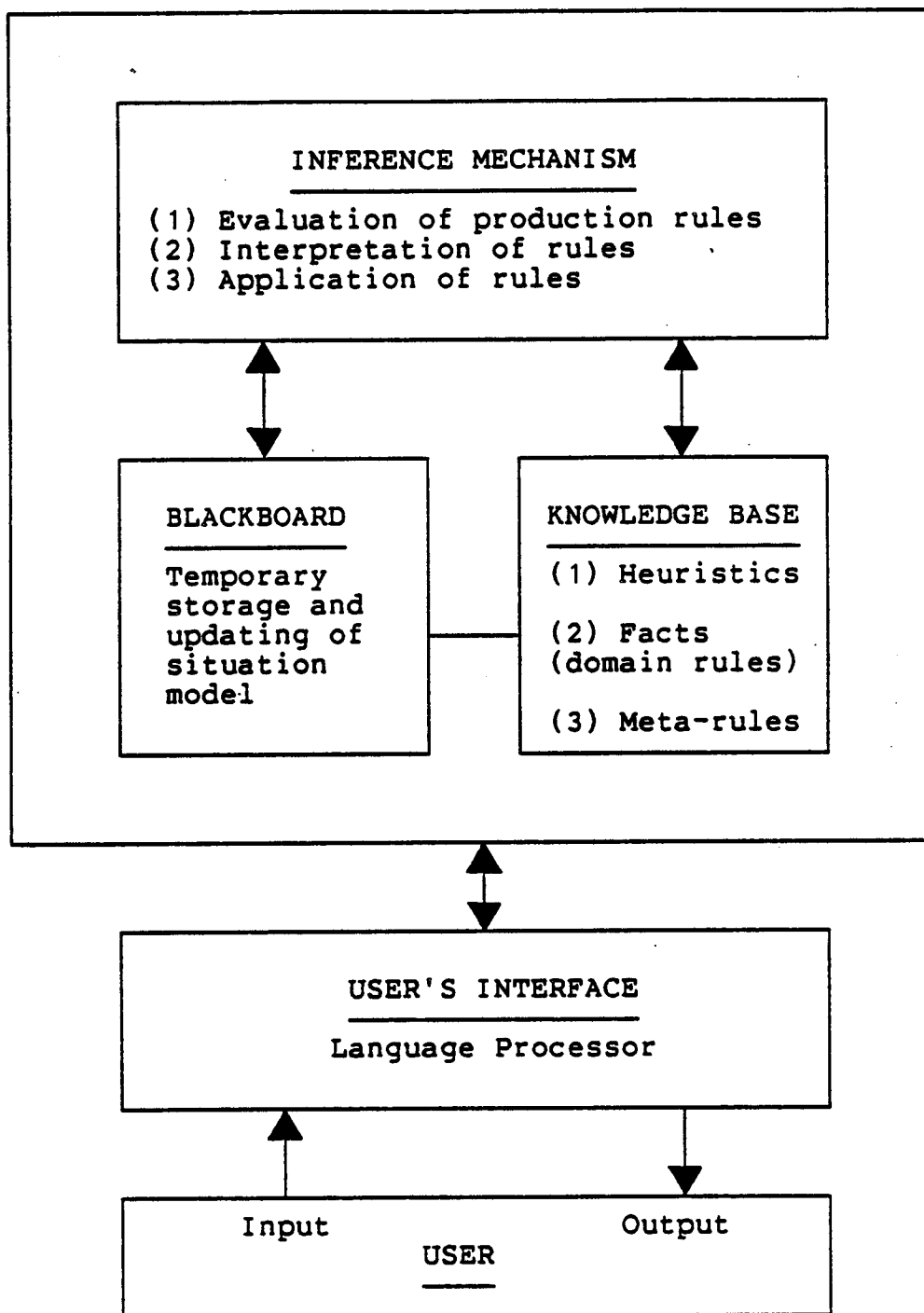

Figure 2.1 Structure of an Expert System

### 2.2.1 The Knowledge Base

Data bases or data structures provide a convenient system for storing information in the form of pieces of data that are more or less self-contained. The sorting of the data is normally done in a structured fashion for efficiency in storing and retrieving the data for user access or for processing by other programs. The way the respective bits of data relate to one another and how well these fit other data is unimportant in data structures.

By contrast, a knowledge base contains knowledge data and relationships that connect such data together with processes that operate on these relationships in order that inferences might be drawn (Elio, 1986).

Various approaches used in structuring knowledge include: list processing, semantic relationships, frame systems, production rule based systems, etc. Amongst the mentioned available techniques used in knowledge representation, it seems that the production rule systems are the most appropriate for the purposes of building structural engineering CAD programs. Production systems comprise a series of modular rules that represent independently chunks of knowledge. These rules entail control structures or logical conditional statements of the form IF-THEN or antecedent-consequent or situation-action (Adeli, 1985).

The production rule system constituting the knowledge base is composed of domain rules and heuristics which

provide the system with the knowledge required in identifying the problem solving techniques, and possibly metarules.

Heuristics represent the knowledge of the expert engineer and supply the necessary information in setting up a solution strategy. Unlike conventional algorithmic rules, owing to the uncertainty involved since there is no closed form solution to the design problem, heuristics provide a pragmatic approach to the problem.

Metarules or rules about rules, constitute a subset of the knowledge structure known as meta-level knowledge base. At a given stage of the reasoning process there may exist a situation where a number of rules are applicable to the same specific problem. Those rules that determine the manner and order in which the production rules are to be invoked are referred to as metarules. For example, one criterion used in formulating metarules can be based on weightings assigned to the domain dependent rules. Such weightings give an indication of the level of usefulness of the particular production rule. In this case, the metarule evaluates the weightings and decides on the most appropriate order in which the rules are to be invoked.

### **2.2.2 The Inference Mechanism**

Earlier it was mentioned that in expert systems the knowledge is applied skillfully in arriving at a solution. Lenat et al. (1979) define skill as the capability of having

knowledge and using it effectively. The role of the inference engine is precisely to simulate such domain skill. This mechanism which is the main component of KBES determines a control reasoning strategy by identifying a potential chain of actions in arriving at a plausible solution to the particular problem. This is normally achieved by:

1. interpreting the production rules from the knowledge base,
2. selecting the rules to use or actions to follow, and
3. invoking the selected rules or actions.

An intelligent control system achieves the above in an efficient manner if:

1. the correct knowledge rules are applied,
2. control is induced at various intermediate levels of the solution process so that frequent checks and revisions are made, and
3. a blind search is avoided, thus eliminating redundant approaches and reducing computer execution time.

Various types of inference mechanisms are described by Hayes-Roth et al. (1983) and Frost (1986). An examination of these mechanisms indicates that the most appropriate control strategies for structural design problems are the forward chaining, backward chaining, and a combination of the two.

In forward chaining, also known as antecedent reasoning or data-driven control strategy, the production rules are

scanned sequentially until a suitable rule or set of rules whose antecedent or IF-part meets the current conditions of the problem. This reasoning scheme is used in program *COLUMN* to select the shape and dimensions of a column section. Production rules based on the ratios of the eccentricities which in turn depend on the loading conditions, are scanned until the logical conditional statements that are consistent with the current design information of the problem, are found.

In the backward chaining scheme, also referred to as consequent reasoning or goal-driven strategy, it is the consequent part of the rules that are investigated and invoked first. A solution is justified if the THEN-part of the rule or a combination of the goals in the consequent part of the rules, match the specified conditions of the problems. This mechanism is efficient for problems that are of a diagnostic nature. Yehia and Bechara (1985) apply a form of this backward scheme in their program for checking designs of columns. A column adequacy check is made by matching the goals first, which in this case are the loading conditions of the input section, with predesigned sections stored in a databank. If the entered loading conditions already exist in the records of the databank, the other design parameters which include section and material properties are then checked. If a complete match is found, the design is complete.

### 2.2.3 The Blackboard

In expert systems, intermediate results or decisions are recorded in a temporary working database or blackboard. The blackboard for the knowledge-based program developed in this research is nothing more than the current values of the variables in the working memory, which are updated in accordance with the state of the design problem generated to that point. Design decisions are also changed or updated every time new additional design data and information is generated.

### 2.3 Knowledge Engineering

A new discipline known as knowledge engineering has emerged as a result of research work in KBES. Knowledge engineering is concerned with the problem of:

1. Abstracting the knowledge from the experts.
2. Identifying the appropriate AI techniques and formalisms for representing the knowledge and the reasoning process.
3. Designing the system.

Ideally this is achieved through various sessions held between two different groups; the people providing the knowledge which in this context are the expert structural engineers, and the knowledge engineers who extract the knowledge and implement it into a suitable expert system framework. Fenves (1986) comments on the above, stating that this approach might not be the most feasible, owing to the

lack of knowledge engineers and the difficulty of providing the specialized knowledge to someone with no background in the domain. It may be easier for the domain engineer to apply directly his or her knowledge via available expert system frameworks which comprise user interface and knowledge acquisition facilities. This situation is analogous with the problem of conventional programming, where the civil engineer had to initially rely on an intermediary person, known as the programmer, in order to translate for the computer the method of representing the analysis or solution to a design problem.

In developing an expert system for the selection of construction plant, Wijesundera and Harris (1985) pose the following questions in their approach for obtaining and representing the required domain knowledge:

1. How to approach the experts
2. How to acquire the knowledge
3. How to encode the knowledge

The knowledge of construction experts which included site engineers and experienced machine operating personnel was extracted using the following methods:

1. Informal conversations
2. Questionnaires
3. Examples

This approach was adopted in acquiring the additional expert knowledge to develop *COLUMN*. Discussions were held with the staff and students in structural engineering at the

University of Alberta, Department of Civil Engineering and practicing engineers, on possible approaches to the engineering logic used in reinforced concrete design process. In addition knowledge was also extracted from a comparative study of a number of manually worked design examples.

Contrary to popular belief, the design process is not merely a trial and error one, but rather involves a logical procedure which entails intuitive decision-making based on the engineering requirements and the acquired expertise of the engineer. Identifying the rules of thumb and good judgement inherent in the engineering logic used in arriving at good designs is not always a straightforward task. Decisions taken during the course of design, which are of a second nature to the designer, are often so inconspicuous that they are difficult to identify and are hard to translate into separate but interrelated chunks of knowledge.

#### **2.4 Programming Languages and Shells**

Prior to the development of an expert system, the various available programming tools must be investigated and evaluated with respect to the particular problem in order to select an appropriate programming medium. There are essentially two possible approaches or tools used in building expert programs.



For certain types of engineering problems it might be feasible to make use of open systems which include the use of declarative languages such as LISP (LIST Processing) or PROLOG, or otherwise the use of high-level languages such as FORTRAN, PASCAL, or BASIC.

The alternative approach in developing expert programs is to use available packages known as 'shells' which have already built-in the essential data structures and mechanisms of expert systems. Incorporating knowledge and reasoning techniques in these shells is constrained by the type of logic reasoning inherent in the inference mechanism of the particular shell. Typical shell programs of this sort, available for both mainframe and microcomputer systems, which employ various logic reasoning mechanisms include *1st CLASS* (1986), *SAVIOR*, and *KES* amongst others (Allwood et al., 1985).

Shell systems are quite efficient in handling logic reasoning that is qualitative or non-numeric in nature, but they require other serviant algorithmic programs to carry out the amount of computational work that is characteristic in structural design problems. Therefore, for structural engineering purposes, shell programs as they are available at present, cannot be used as a stand-alone system, but have to be used in conjunction with other numerical algorithmic programs (Fenves, 1986).

Since one of the main tasks of this research was to study the various components of CAD expert programs and how

they are integrated, the use of empty shells was not considered.

The programming language used in developing *COLUMN* is FORTRAN 77. This high-level language was selected because it represents well the rule based propositional logic which involves numeric matching of the IF-THEN-ELSE format. In addition, FORTRAN 77 is most appropriate for the numerical computational analysis required in design process. The use of such a language provides an open system which as the name implies has the advantages of allowing for addition, modification, and alterations to the programs.

As already indicated, the development of an expert program is primarily based on recognizing and accumulating the specific knowledge and the task of representing it. The programming medium adopted, be it a shell, or a language, although important, is a secondary issue. Changing the medium by which to represent the knowledge for the purposes of improving the system, takes much less time and effort than that used in accumulating the knowledge.

## **2.5 User-Machine Interface**

A preferred feature in CAD programs is a user friendly communication link to the computer. Various sorts of user interfaces include: the conversational type, interactive graphics, or menu-driven type.

The conversational type can be of two forms, namely:

1. A batch or direct insertion type, in which an input file

including basic data is set up and then read in batch by the program. The records in the file can be one of the following types:

- a. Formatted - In this type of input, the records comprising a sequence of characters are terminated by a system dependent end-of-line marker. The data is interpreted in a manner consistent with a preset input format.
  - b. Unformatted - The data or information, although entered in a specified sequential form, does not have to conform to any specific format.
  - c. Key word type - A set of sequences of characters representing particular parameters followed by an equal sign and the respective values of the parameters are entered. The sequence in which the variable names are input is unimportant.
2. An interactive input type in which the program prompts a series of questions requesting data and information from the user.

The batch unformatted type and the interactive type constitute the two optional operational input modes used in the system developed in this research. The interactive mode offers a user friendly interface, since it provides the user with guidance in entering data in a step-by-step fashion. On the other hand, the batch mode proves to be efficient to the frequent user, since once an input file is set up, designs with slightly varying constraints or conditions can be

easily produced with a minimum amount of effort by modifying the existing input file. Input data is entered via a terminal keyboard in both operational modes.

The use of formatted type of input is much less user friendly since setting up a file with records that must adhere strictly to a prespecified format is a tedious and a time consuming task.

The key word input is considered to be a good user-machine interface but seems to be more appropriate when used for purposes of revising or altering any parameters of an already executed design. In order to read this form of input, the program requires a special module that is capable of interpreting the names of the variables and their respective values.

A derivative of the key word type of input is the menu-driven input. Such input is used by the program (*ADOSS*, 1985) for the analysis and design of slab systems which prompts the user with a series of screen input pages composed of a number of data locations. The menu items are located using cursor keys and the relevant input is entered in the data items provided. The user is directed in inputting his data since he can only enter data which is consistent with constraints prespecified by the program. An additional desirable feature that is incorporated in the menu-driven input used by *ADOSS*, is that once the menu item is selected, all data associated with the selection is updated to conform with the particulars of the selection.

For example, if in the first input screen page a particular code is selected, the following data items prompted are all consistent with the building code selected.

The use of interactive graphics for purposes of input is mostly appropriate for CAD programs for large systems such as multistorey framed structures, where large amounts of information and input data regarding the configuration of the structure is normally required. This type of user interface has been made use of in the programs for the static and dynamic analysis of frames developed at the Department of Structural Engineering at Cornell University (Gattass et al., 1983) and programs for the design of reinforced concrete buildings developed at the Department of Civil Engineering at the University of Colorado (Saouma et al., 1984).

The other part of user-machine interface is concerned with the output of the design results. Typical output of results of CAD programs, besides being printed on the screen terminal are also printed on a hard copy in a written or graphical form, via output devices which include a line printer or a plotter. Although the graphical output has not been considered in this study, it is a desirable feature for CAD systems. A separate module that interprets the final design results and links to available drafting and drawing software such as *AUTOCAD*, can be incorporated to produce detailed drawings of designs.

## 2.6 Host Hardware

Until recently, sophisticated CAD programs for structural engineering had to be written exclusively for use on a mainframe computer (such as the Amdhal computer which operates under MTS that is available at the University of Alberta), since these programs required an appreciable amount of memory. The major and significant drawback to such programs is that they are system dependent and therefore cannot be used on other computer environments that may be available to practicing engineers.

In the recent past, microcomputers and other compatible peripheral devices with sufficient capacity and speed have been developed that are affordable to most engineering offices. This feature renders microcomputers a perfect environment for developing software, since, any program written for such systems are portable.

### 3. EXPERT PROGRAMMING FOR STRUCTURAL DESIGN

#### 3.1 Introduction

The concepts of expert systems and their general application to various fields were discussed in Chapter 2. In the context of KBES for the design of structural members in general and reinforced concrete members in particular additional features are required. These features are discussed in this chapter.

#### 3.2 Design Criteria

The goal of CAD in structural design is that the final design be deemed satisfactory; that is the design is:

1. Safe and serviceable
2. Constructable
3. Economical
4. In accordance with prescribed limitations imposed by the designer

These design criteria form the basis for the development of all production rules and inference mechanisms used in KBES for structural design.

In reinforced concrete design and the design of certain steel sections such as plate girders, the member cross sections are not preformed stock items but are individually selected to meet specific loading requirements using standardized sizes of components and construction requirements. This requires production rules and design

strategies that are unique to a given problem.

For example, in proportioning a reinforced concrete column section, decisions consistent with the above design criteria must be made to such items as:

1. The choice of the shape of cross section; when would a rectangular shape with a certain aspect ratio be advantageous to use over a circular shape of the same area.
2. Limitations on the number of reinforcing bars and bar diameters.
3. Selection of the appropriate reinforcement ratios considering detailing aspects such as, development and splice lengths and spacing of reinforcement.
4. Choice of reinforcement pattern; whether to place bars on two faces or on all faces of the column.
5. Criteria to use in incrementing or decrementing the size of bars, number of bars or dimensions of section.

The means by which such decisions are made in *COLUMN* are presented in Chapter 4.

### 3.3 Control by the Designer

In practice, the engineer must ultimately take responsibility for the design. Moreover, adjustment may be required to the design to accommodate last minute changes required by the architectural or mechanical aspects that are unique to a particular structure. Therefore, the program must have provision for the designer to impose *a priori* any



restrictions on dimension tolerances, bar size, number and arrangement of reinforcing bars. This means that at each decision step there is the opportunity for the designer to impose a different heuristic or strategy that will be recognized by the program and will override the resident heuristics. The same procedure can be used to alter heuristics in the program so that the designer can create a tailor made system for a particular project.

### 3.4 Design Philosophy

An important and essential aspect to be dealt with in the initial phase of building structural engineering CAD programs is the choice of an overall design philosophy. This includes the selection of appropriate mathematical design models. While retaining the important basic characteristics of the structural behaviour, a number of idealizations and assumptions are made in order to reduce a complex problem of design to one that can be approached by a relatively simple mathematical treatment. This applies especially with reinforced concrete design. Such simplifications normally concern geometric and material properties of the actual structure.

Achieving overall consistency is an important issue in building a comprehensive CAD environment. The design philosophy and assumptions used in formulating the mathematical models should provide a coherent level of sophistication in all the programs constituting the system,

if the results are to be meaningful. Abiding to this approach ensures compatibility and consonance between the modules; so when integrated, they yield an overall consistent structural engineering CAD system.

For example, the use of a complete second-order nonlinear structural analysis in conjunction with the moment magnifier design procedure stipulated in the building codes does not provide a consistent approach. The moment magnifier design model is introduced to compensate for known inconsistencies when the stress resultants have been obtained using a linear elastic analysis. Such a design procedure is not required nor will it give economical results if it is used in conjunction with a second-order analysis. Therefore, to ensure overall consistency is achieved, at no stage of the design process should a level of sophistication be used that is inconsistent with that applied up to that stage.

### **3.5 Incorporation of Codes**

The design philosophy implemented in the program developed for this study are those adopted by North American Codes which include:

1. CSA CAN3-A23.3-M77
2. CSA CAN3-A23.3-M84
3. ACI 318-83

The decision to opt for approaches and models that are in accordance with building code specifications was made for

three reasons:

1. In most practical design cases, adherence to a specific Building Code is stipulated in the contract of works. These codes, in turn, require that design is performed in accordance with other codes such as those indicated above.
2. Specifications in standards provide a source of accumulated design knowledge which is readily available. Codes summarize a vast amount of empirical research into a set of workable design rules. They give guidance in the selection of models and provide information about constructibility, safety and serviceability requirements and other design aspects. Lack of conformance with codes would require setting up criteria to cater for such design aspects. For CAD programs, this is not a justified approach, unless the system to be developed concerns design of specialized structures that are not treated in a thorough manner in the codes.
3. Codes, in general, focus on one coherent design philosophy. Factors used in standards, for loadings and material properties, together with assumptions made in idealizing actual structures, constitute a global consistent design procedure which forms a potential framework for CAD purposes. In addition, specifications stipulate possible alternative methods of analysis that are in compliance with the level of sophistication inherent in the detailing and proportioning provisions.

There are, however, some shortfalls in the codes with respect to them being implemented in CAD programs. Specifications which are becoming more complex are still written with the intent that they will be used with manual design procedures. Little provision, if any, is given to the possibility that design specifications can be automated with the aid of a computer. Consequently, incorporating certain clauses given in the codes, in the program presented herein, did not always prove to be a straightforward and easy task. Interpretations of certain code provisions, which are not clear, also created difficulty in the writing of programs.

### 3.6 Modularity of CAD Systems

Program organization is another important aspect that requires several considerations. A good approach for structuring a CAD system is to subdivide it into distinct modules that perform single particular tasks only (Szalwinski et al., 1977; Augusti and Borri, 1984). Modularity ensures flexibility in the system since it allows easy updating and overlay structuring of the program and facilitates the design checking and debugging of syntax and logic errors. Also, a good 'top-down' style of programming is achieved through the subdivision of programs into modules.

One reason for updating programs is to cater for changes and improvements in the code requirements. Whilst minor changes such as those in the values of load

factors can be easily implemented, fundamental changes that concern the basic design philosophy such as the substitution of working stress design criteria by limit states design approach require drastic changes in the framework of the program. This normally entails rewriting whole program modules. The same situation occurs when provision is made to incorporate in the program design in accordance with other international standards.

Other important changes that need to be accounted for in the development stage of CAD programs are those concerning the expansion of the design knowledge. Refinement and addition of the knowledge in the programs entails incorporating new production rules to the knowledge base and adjusting accordingly the inference mechanism. Alterations and additions of this sort can easily be done when the programs are written in modular form.

The modules used in program structuring can be described or classified using two systems.

1. Modules that describe the nature of the particular design task, namely:
  - a. Numerical algorithmic modules that do the 'number crunching' work in accordance with well defined mathematical relationships.
  - b. Knowledge-based modules that include design knowledge in the form of a series of production rules.
  - c. Decision-making modules that select and apply a

- design control strategy.
- d. Database modules that permanently store design parameters including those stipulated in codes.
2. Modules that represent a principal phase of the design procedure, namely:
- a. Input module that reads general information on the design problem, material and geometrical properties, loading and stability information.
  - b. Output modules that give results to the design problem.
  - c. Analysis modules that compute the values for design parameters in accordance with codes or well established design criteria.
  - d. Detailing and proportioning modules that decide on the section dimensions and reinforcing patterns.
  - e. Modules that carry out adequacy checks for strength, serviceability, and constructibility.
  - f. Modules that increment or decrement section dimensions and reinforcement.

A particular module can usually be classified under either system (Fig. 3.1).

### 3.7 Solution Strategies

Ofttimes, the solution algorithms applied in manual design do not prove to be the most efficient for computer applications. In deciding upon a solution algorithm, advantage should be taken of the ability of the computer to

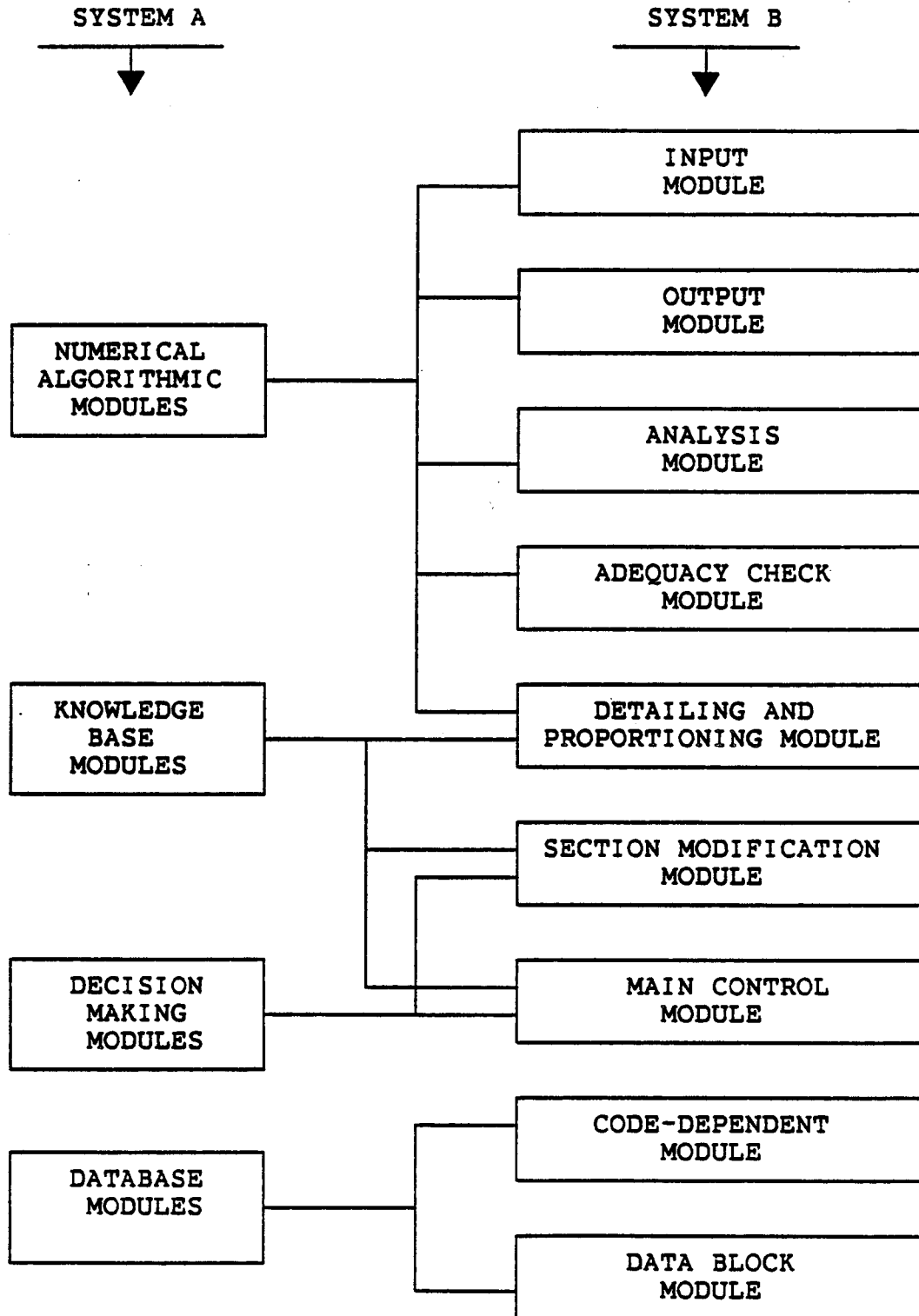

Figure 3.1 Correlation between Module Classification

execute quickly a sequence of operations.

An intelligent control module that reduces redundant operational steps by selecting a design strategy that optimizes execution efficiency, is used to link all modules. The structure of the control module depends on the type of solution route to the design problem. Basically there are two types of design routes (Clarke, 1978).

In the first type, known as automatic CAD or the complete cycle approach, the required input parameters, including any designer limitations or requirements are entered. The program is then run without any further external directives or user intervention, until a complete design is executed. Hence, the solution strategy must be decided entirely by the program itself and therefore requires an appropriate design knowledge base.

In comparison, in the second type known as decision design, the program requests information and decisions at appropriate stages of the design process, therefore the designer intermittently interacts with the computer to control the course of the solution procedure. The program, following an evaluation of intermediate phases of the design process, stops running and requests information from the designer in order for it to proceed further with the design solution. While such an approach is frequently appropriate for use in expert systems where the problem is diagnostic in nature, it is not appropriate for proportioning and detailing in structural design.



The automatic design approach is more complex to implement and the execution time in this approach is greater when compared to the decision design method. Notwithstanding this, the increase in execution time is small and overall the automatic design approach is more cost effective. Moreover, any modifications required after a complete run of a design can be made with the minimum amount of the engineer's time.

Consistent with the requirement of an automatic expert environment, the complete design approach was opted for in the development of *COLUMN*.

## 4. ENGINEERING LOGIC USED IN *COLUMN*

### 4.1 Program Scope and Capabilities

Program *COLUMN* was written to demonstrate the requirements of a computer program that, given the same information, will proportion a reinforced concrete column section that is comparable to that produced by an experienced structural engineer. *COLUMN* is therefore, a knowledge-based expert system in the domain of proportioning and detailing reinforced concrete columns.

When writing *COLUMN*, emphasis was placed on developing the heuristics and inference mechanisms that are required to select a column section with only the minimum information to define the boundaries of the problem. These are discussed in detail. It is realized that different heuristics and reasoning strategies are required when limitations are imposed on the problem by the user. While provisions have been made for many combinations of user restrictions, it should be noted that all possible combinations have not necessarily been considered. There may be some cases when the program returns a message that a satisfactory design cannot be completed with the restraints imposed when, in fact, such a design is possible. However, this occurs only in exceptional cases. It has been observed that the heuristics become simpler when more restrictions are imposed since the number of independent solutions is reduced. These can be easily incorporated to expand the knowledge of the

program.

Since *COLUMN* was conceived to be part of a comprehensive integrated CAD system, the modules concerned with data input have been isolated. In a CAD environment, data would be obtained from a global database into which the required information would have been placed by other expert programs. In the absence of such a database, *COLUMN* as written, is a stand-alone program and input must be user entered.

As knowledge of the remaining structure is unavailable certain minimum input and assumptions are required. The design strategy used in *COLUMN* assumes that all input axial loads and moments are obtained from an elastic first-order analysis, hence slenderness effects are considered using the moment magnifier method. As a result, stability information in the form of the effective length in each principal direction and, in an unbraced direction, the proportion of the loading parameters that cause appreciable sideways are required.

For ease of fabrication and placing during construction, most columns used in practice are symmetrically reinforced and are rectangular or circular in shape. *COLUMN* is capable of proportioning and detailing the types of column sections illustrated in Fig. 4.1. Reinforcement patterns are symmetrical about the principal axes and therefore consist of an even numbers of bars. In the case of both tied and spiral columns the reinforcement

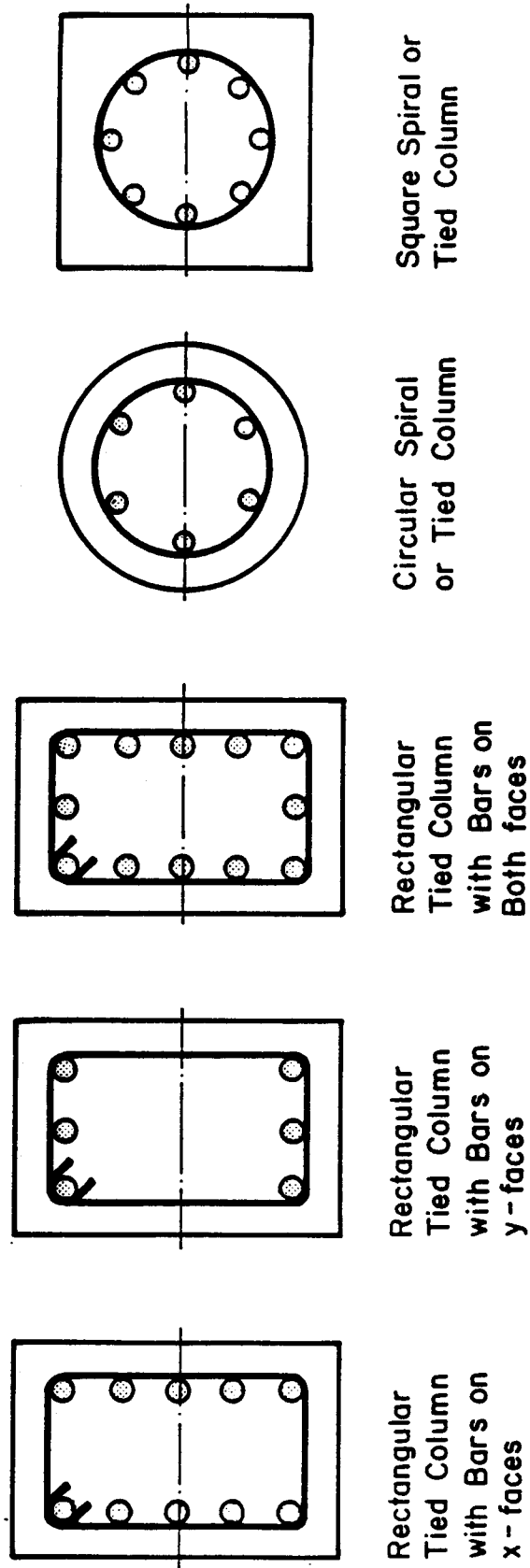

Rectangular Tied Column with Bars on x-faces

Rectangular Tied Column with Bars on y-faces

Rectangular Tied Column with Bars on Both faces

Circular Spiral or Tied Column

Square Spiral or Tied Column

Figure 4.1 Sections Considered by COLUMN

is placed in one layer or circle, and within a column cross section, all bars are of the same size. The existing knowledge base could be amended to render the program capable of selecting mixed bar sizes and/or bundled bars, when appropriate. The columns designed by the program can be long or short, braced or unbraced against sidesway, tied or spiral and uniaxially or biaxially loaded. However, again due to lack of data available regarding the overall structure for decision making, the program defaults to rectangular tied columns. Circular or spiral columns will only be considered when user specified.

*COLUMN* can be used in a 'design' or 'check' mode. In design mode, for a particular set of loadings, material properties and a set of constraints imposed by the designer, a column section including selection of reinforcement is determined by the program. In check mode, in addition to the loading and material properties, the user enters complete information regarding column dimensions and reinforcement. The program then merely determines whether the entered section is adequate for the specified loading.

The general design logic and philosophy implemented in the program are described in the following sections. The detailed features and computational work involved in the analysis is described in Appendix A, and the procedure for using the program is explained in the USER'S MANUAL in Appendix B.

#### 4.2 General Design Strategy used in Developing *COLUMN*

The task of designing a reinforced concrete column consists of selecting an economical cross section that is capable of safely supporting the applied loads. This design should also satisfy the serviceability requirements and other constraints that are dependent on the particular project.

The engineer, through his or her acquired knowledge and expertise has the ability of recognizing the alternative potential column designs, and isolates the one deemed to be the most appropriate. Then, a detailed analysis of the tentative design is performed to evaluate whether the strength capacity is adequate. If the section is found inadequate, the engineer modifies the design by incrementing or decrementing the concrete cross section dimensions, or the amount of reinforcement, or otherwise considers an alternative shape of cross section.

The design strategy and knowledge base implemented in the program *COLUMN* utilizes the same design logic with one exception; the program selects an initial trial section known to have the minimum concrete dimensions and minimum amount of reinforcement consistent with the loading conditions and constructibility requirements. The strength capacity of the trial section is evaluated and compared with the required capacity. If the section is not sufficient, the concrete section or reinforcement is incremented. Since the modification of the section entails incrementing either the

area of reinforcement or the column dimensions with one increment step at a time, *COLUMN*, ensures that the final design is the most economical in terms of the volume of concrete and amount of reinforcement.

The various steps that simulate the above design procedure constitute the general reasoning strategy incorporated in the program *COLUMN*. These steps can be summarized as follows:

1. Selection of initial section
  - a. Compute minimum area of concrete section consistent with loading conditions.
  - b. Select an appropriate column aspect ratio and concrete dimensions - module *DIMEN*
  - c. Select a reinforcement pattern - module *REPAT*
  - d. Select a minimum area of steel reinforcement and a minimum bar combination - module *REINF*.
2. Evaluation of section
  - a. Account for slenderness effects by magnifying the moments if necessary - modules *SLENDX* and *SLENDY*.
  - b. Compute axial load and moment capacity of trial design - module *CAPAC*.
3. Modification of section - module *INCRE*

When in design mode, all of the steps are invoked, however, when in check mode, only Step 2 of the process is used.

Since the program has no *a priori* knowledge of the possible solution, the reasoning mechanism employed is the data-driven type. A forward chaining reasoning scheme is

invoked on the production rules incorporated in the knowledge-based modules indicated in Stages 1a to 1d. The decision trees of possible section dimensions and bar combinations are evaluated and scanned until a potential solution is achieved.

The numerical algorithmic subroutines indicated in Stages 2a and 2b determine whether the selected section is satisfactory. If the trial design is inadequate, the section is incremented (Stage 3) and the system backtracks to the initial design stage in order to select a more appropriate design. This iterative process is invoked until a satisfactory solution that meets all the requirements is achieved. This process and the manner in which the various modules are coupled is illustrated in Fig. 4.2. The design knowledge and analytical solution strategies employed in this dialectical process are described in detail in the following sections.

#### 4.3 Column Section Proportioning and Detailing

##### 4.3.1 Selection of Initial Concrete Section

When neither or at most one of the column dimensions is user specified, a minimum gross area of section  $A_g^o$  is computed using a modified form of the code equations for the design axial load strength of compression members:

$$A_g^o = \frac{P_u}{\phi a_c [0.85f'_c + \rho_g (f_y - 0.85f'_c)]} \quad [4.1]$$



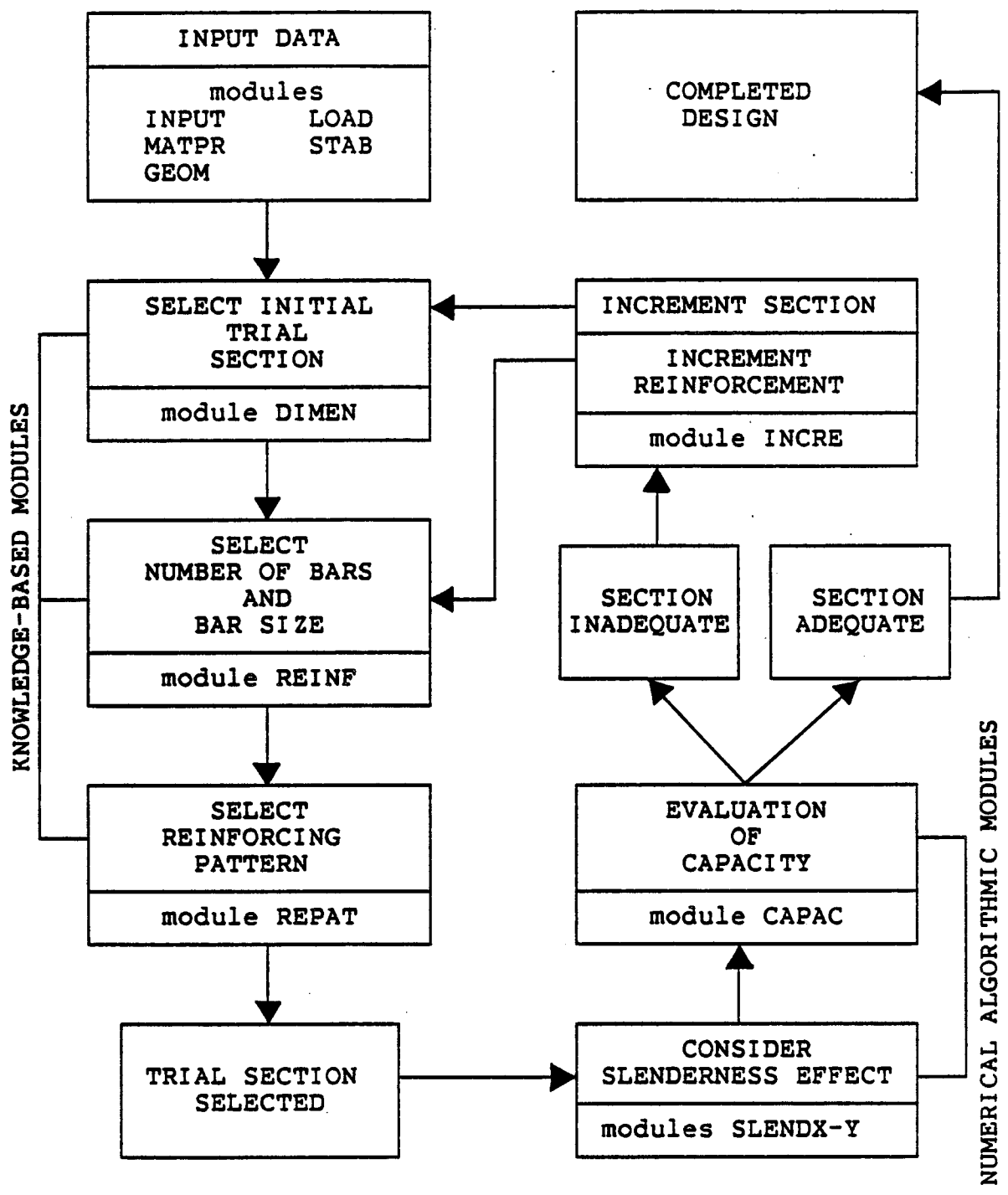

Figure 4.2 General Design Strategy Used in COLUMN

for CAN3-A23.3-M77 and ACI 318-83, and

$$A_g^o = \frac{P_f}{\alpha_c [0.85\phi_c f'_c + \rho_g (\phi_s f_y - 0.85\phi_c f'_c)]} \quad [4.2]$$

for CAN3-A23.3-M84, where  $P_u$  and  $P_f$  are the values of the axial loads computed from entered dead and live loads acting on the column and  $\alpha_c$  defaults to a value of 0.85 for spiral columns and 0.80 for tied columns.

In order to ensure that the smallest possible concrete section is selected, the value of  $\rho_g$  used in the above equations is the maximum reinforcement ratio which is either specified by the user or assigned a value of 0.03 by the program. If user specified, the value of maximum reinforcement ratio must not be less than 0.01 or greater than 0.08 to conform with code limits. Values of  $\rho_g$  approaching 0.04 outside the region of lap splices can create some practical difficulties in fitting the reinforcing bars, placing and compacting concrete. Thus, for economic and constructibility purposes, the default value for the maximum reinforcement ratio was limited to the value of 0.03.

Once a minimum gross area of section is computed, the corresponding theoretical dimensions can be obtained easily if the specified shape of the column is square or circular or, if rectangular, one of the column dimensions or column aspect ratio is specified, since in each case only one unknown parameter is involved. The actual dimensions for the

trial section are obtained from these theoretical dimensions by increasing them to a multiple of a length increment. This length increment, if not user entered, defaults to 2 in. when using Imperial units and 50 mm when using SI units. In addition, all section dimensions are checked to ensure that they are not less than the minimum dimension which is 8 in. or 200 mm. This minimum dimension is considered to be the smallest dimension that can be physically built with the type of materials envisioned by the codes. Therefore, an error message results if a dimension less than the minimum is user entered.

When the shape of the column cross section is not stipulated by the user, *COLUMN* selects a rectangular section with an aspect ratio,  $R$ , (where  $R = c_x/c_y$ ) so as to resist the applied loading in an efficient manner. Essentially the paradigm used in the inference rules evaluates the loading condition by computing the eccentricity of the axial load. This parameter determined by  $e_x = M_y/P$  or  $e_y = M_x/P$  gives an indication of the predominate loading action. A value of  $e$  that is large compared to the column dimension obviously infers that the moment prevails over the axial load and vice versa. The ratio of this eccentricity to the column dimension (computed from the area of concrete by assuming the section is square), denoted by  $e_x/c_x$  or  $e_y/c_y$  forms the main attribute of the rules. A typical network of rules are summarized in Fig. 4.3. Unless otherwise specified by the user, *COLUMN* limits the value of  $R$  between 0.5 and 2.0.

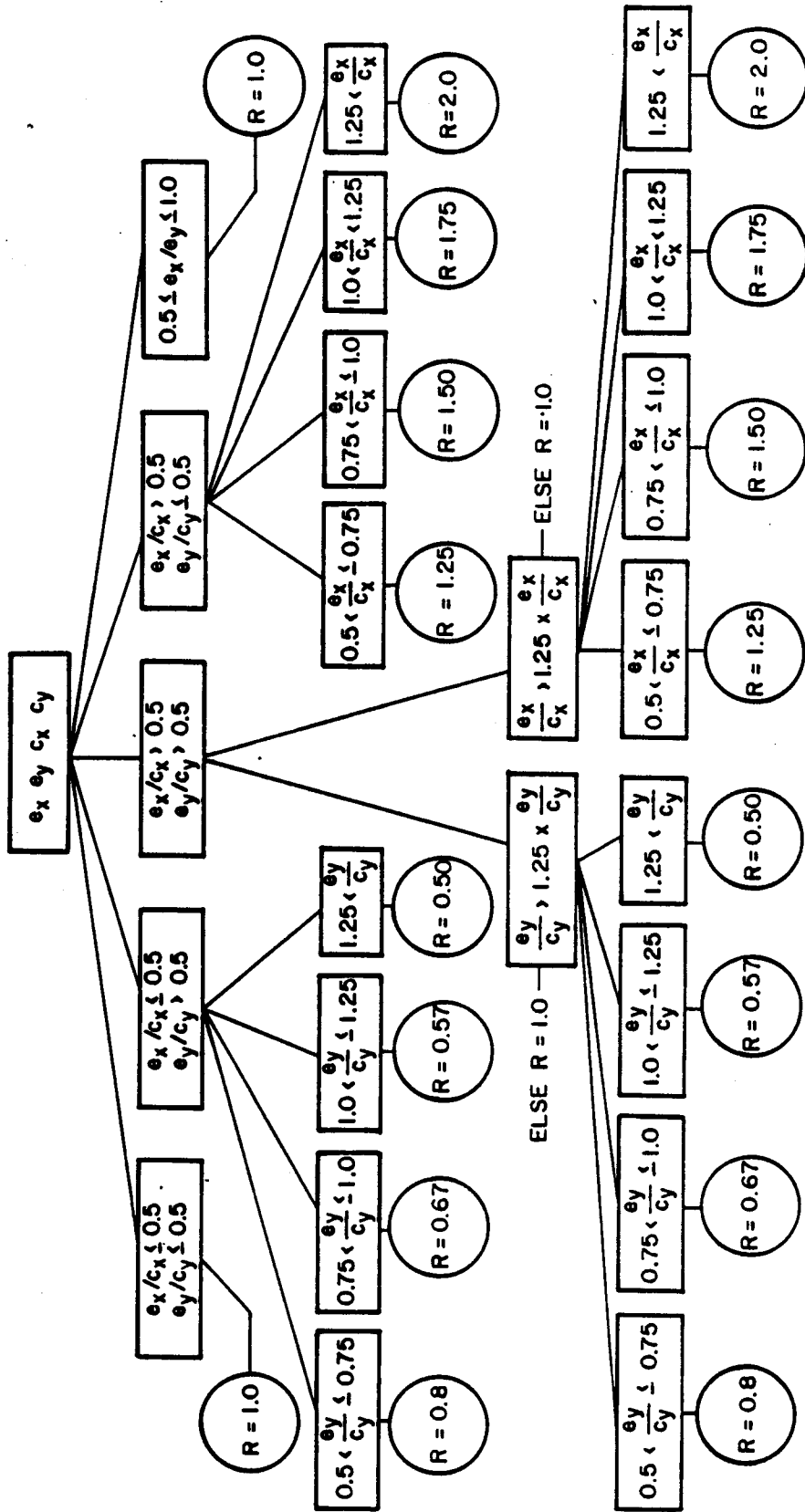

Figure 4.3 Rule Network for Selection of R for Columns Subjected to Biaxial Bending

The values of the parameters implemented in the production rules were selected on the basis of a number of trial designs performed as follows. For various values of  $R$ , the range of the ratios  $e/c$  that result in steel ratios,  $\rho_g$ , between 0.01 and 0.03 are determined by entering a given column interaction diagram with an assumed value of  $A_g$  and  $P_f$ . This process is repeated with different values of  $A_g$  and  $P_f$ . It was observed that when this procedure was applied to different column interaction diagrams there was a correlation between  $R$  and  $e/c$ . At this stage of the design, although a trial value of  $A_g$  is known, the value of  $R$  (and hence  $c$ ) is unknown. Consequently, for the purposes of formulating the production rules, the ratio of  $e/c$  is determined by computing  $c$  from  $A_g$  assuming a square section. Although the values of  $R$  were modified to account for this method of computation, these values are approximate since they are selected in a manner such that they are applicable to different combinations of section geometries and load intensities. It should also be noted that  $R$  is only used as a guide in determining the trial dimensions; the actual dimensions are obtained by modifying the trial dimensions to be a multiple of the length increment.

#### 4.3.2 Selection of Longitudinal Reinforcement

In the context of an automated CAD system, the selection of longitudinal reinforcement turns out to be a complex problem, since for the same loading conditions, a

number of bar combinations can be used. The choice of reinforcement entails selecting the number, size, and placement pattern of the bars.

In the absence of user direction, *COLUMN* uses a criteria to determine the reinforcing pattern that is similar to that used in determining the column aspect ratio. When either the axial load or the moments about both principal axes result in similar eccentricity ratios, bars are placed on all four faces of the column. However, should one moment dominate, not only will the column be elongated to assist in resisting the moment, but reinforcement will be placed only on the two short faces for greater efficiency.

The network of inference rules for determining whether to reinforce the column in two or four faces is shown in Fig. 4.4. These rules take the form:

IF < antecedent (a) > AND < antecedent (b) >  
THEN < consequent >

where < antecedent (a) > represents the loading condition, and < antecedent (b) > represents the range of magnitude of the ratio  $e_x/c_x$ ,  $e_y/c_y$  or  $e_x/e_y$ . One such typical rule is given by:

IF < BIAXIAL BENDING > THEN  
IF <  $1.0 < e_x/e_y \leq 1.25$  > THEN  
< BARS ON BOTH FACES ( $N_y \approx N_x$ ) >

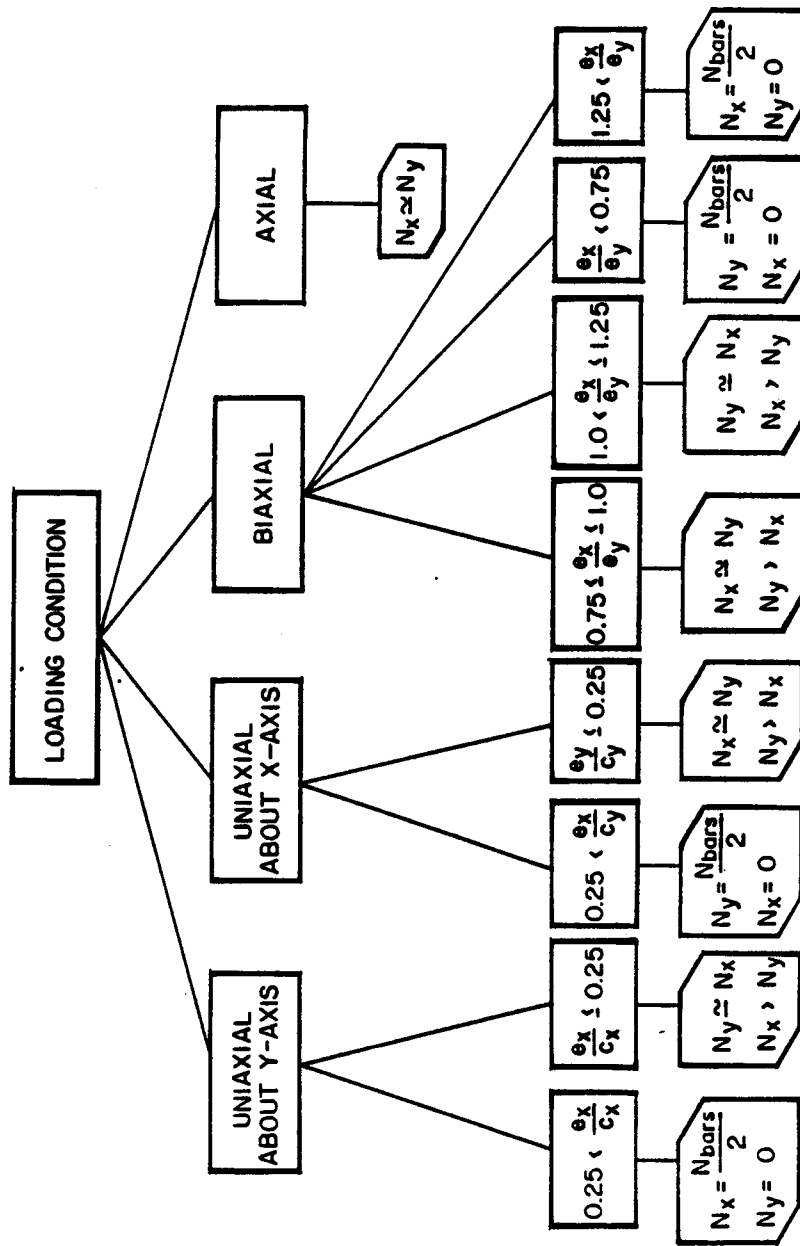

Figure 4.4 Production Rules for Selecting Reinforcing Pattern

In practice, unless the splice length is the governing factor, it is usually more economical to use the smallest number of bars that will give the required area and meet minimum spacing requirements since the required number of ties and labour is a minimum. This design approach forms the basis of the reasoning strategy implemented in the knowledge-based subroutine *REINF* in selecting the bar combination.

Unless specified otherwise, the minimum and maximum bar sizes considered by the program are #5 and #11 in Imperial units and #15 and #35 in SI units. Larger bars are only considered when specifically requested by the user.

The procedure implemented in *COLUMN* for selecting the reinforcement and modification of the trial design is as follows:

1. Select an appropriate reinforcement pattern; bars are placed in two or in all four faces.
2. Determine the value of the minimum area of reinforcement,  $A_s$  min. This is computed as 0.01 times the gross area of of the initial trial section or the revised concrete section.
3. Compute a range of number of bars consistent with the section dimensions. The minimum and maximum number of bars per face, as given in Table 4.1, are computed using the following expressions:

$$\text{min. no. of bars per face} = \frac{C}{k} + 1 \quad [4.3]$$



Table 4.1 Number of Bars in Each Column Face

column dimension		number of bars in face
in.	mm	
8 - 14	200 - 350	2 - 3
16 - 22	400 - 550	3 - 4
24 - 30	600 - 750	4 - 5
32 - 38	800 - 950	5 - 6
40 - 46	1000 - 1150	6 - 7
48 - 54	1200 - 1350	7 - 8
etc.		

$$\text{max. no. of bars per face} = \frac{C}{k} + 2 \quad [4.4]$$

where  $k = 8$  in. in Imperial units and 200 mm in SI units. When bars are placed in two faces only, the total number of bars is twice the number in one face. In the case where the bars are placed on all four faces, the total number of bars is two times the number of bars on two adjacent faces minus four. For example for a 300 mm  $\times$  600 mm column section reinforced on all faces, the total minimum and maximum number of bars considered by *COLUMN* is given by:

$$\text{min. no. of bars} = (2 + 4) \times 2 - 4 = 8$$

$$\text{max. no. of bars} = (3 + 5) \times 2 - 4 = 12$$

4. Starting with the minimum bar size and the minimum number of bars in the selected range of bars for the section, the corresponding area of reinforcement  $A_s$  is computed. If  $A_s \geq A_{s \text{ min}}$  then the section is checked for strength adequacy. However, if  $A_s < A_{s \text{ min}}$  the number of bars are incremented first. If the maximum number of bars in the selected range is reached, the bar size is increased.
5. This is repeated until either:
  - a. the maximum bar size is tried,
  - b. the section is found to be adequate, or
  - c. reinforcement ratio  $\rho$  exceeds  $\rho_{\text{max}}$ ,

in which case the column dimensions are incremented. If the specified column shape is square, both dimensions are incremented by one length increment. When the user specifies one of the dimensions, only the unspecified dimension is incremented. In the case where the column section is rectangular, the initial  $A_g^o$  or the current area of section, is incremented by an area equal to the length increment times the smaller column dimension and the system backtracks to determine a new value of R. The whole design process is then invoked until a column section that meets all the serviceability and safety requirements, is found.

If the program is used in check mode the number of bars on the faces and bar size has to be entered. In this mode, the bar is specified by assigning equal values to the minimum and maximum bar size. If these values are not equal, the program uses only the minimum bar size.

Whether entered or selected by the program, the number of bars are checked with the permitted minimum number of bars for the particular shape of cross section in accordance with building code requirements.

#### **4.4 Evaluation of Strength Capacity**

##### **4.4.1 Second Order Effects in Columns**

In determining the maximum end design moment of a column, the program utilizes the moment magnifier method.

Consequently, *COLUMN* requires information regarding the stability conditions.

If the program were a part of a comprehensive CAD system, this information would be made available via the global database. However, since at present, *COLUMN* is used as a stand-alone system, the values for the effective length factors ( $k$ ) and the information on the end bracing conditions need to be specified. An alternative approach would be for the program to select a value of  $k$  from a set of production rules that are capable of selecting the effective length factors on the basis of user specified information on the end framing conditions. The heuristic knowledge required for this approach can be based on information provided in Figure C1 of Appendix C of CAN3-A23.3-M84 or in Section 3.8.1.6.2 and Tables 3.21 and 3.22 of the British Standard for Structural Use of Concrete (BS 8110:Part1:1985). This approach would, of course, result in more input than the approach implemented.

The moment magnifier method as implemented in the program including comments on the interpretation of the pertinent code specifications, is explained in detail in Appendix A.

#### **4.4.2 Strength Capacity of Section**

At this stage of the design procedure an initial column section including concrete dimensions, amount and arrangement of reinforcement has been selected. This column

section has been checked for the slenderness effects and the moments are magnified if necessary. Essentially then, the design problem has been reduced to an analysis problem where the strength capacity needs to be checked against the applied factored axial loads and moments.

The nominal strength capacity of the section which is uniaxially loaded is computed using design assumptions stipulated in the codes which are summarized below and illustrated in Fig. 4.5.

1. Conditions of strain compatibility and equilibrium of forces must be satisfied.
2. A linear strain relationship is used, hence the strains in steel and concrete are proportional to the distance from the neutral axis.
3. Maximum compressive strain in concrete is 0.003.
4. Stress in steel is equal to the steel strain times the modulus of elasticity of steel  $E_s$ , which has to be equal to or less than  $f_y$ .
5. Concrete takes no tension.
6. An equivalent rectangular concrete stress block (Whitney stress block) as shown in Fig. 4.5 is used to approximate the parabolic stress block.

The solution algorithm used in *COLUMN* first checks whether the capacity of the section for the pure axial compression case is larger than the applied axial load. If this capacity is greater than the applied load, then the neutral axis for the case when the resisting axial load is

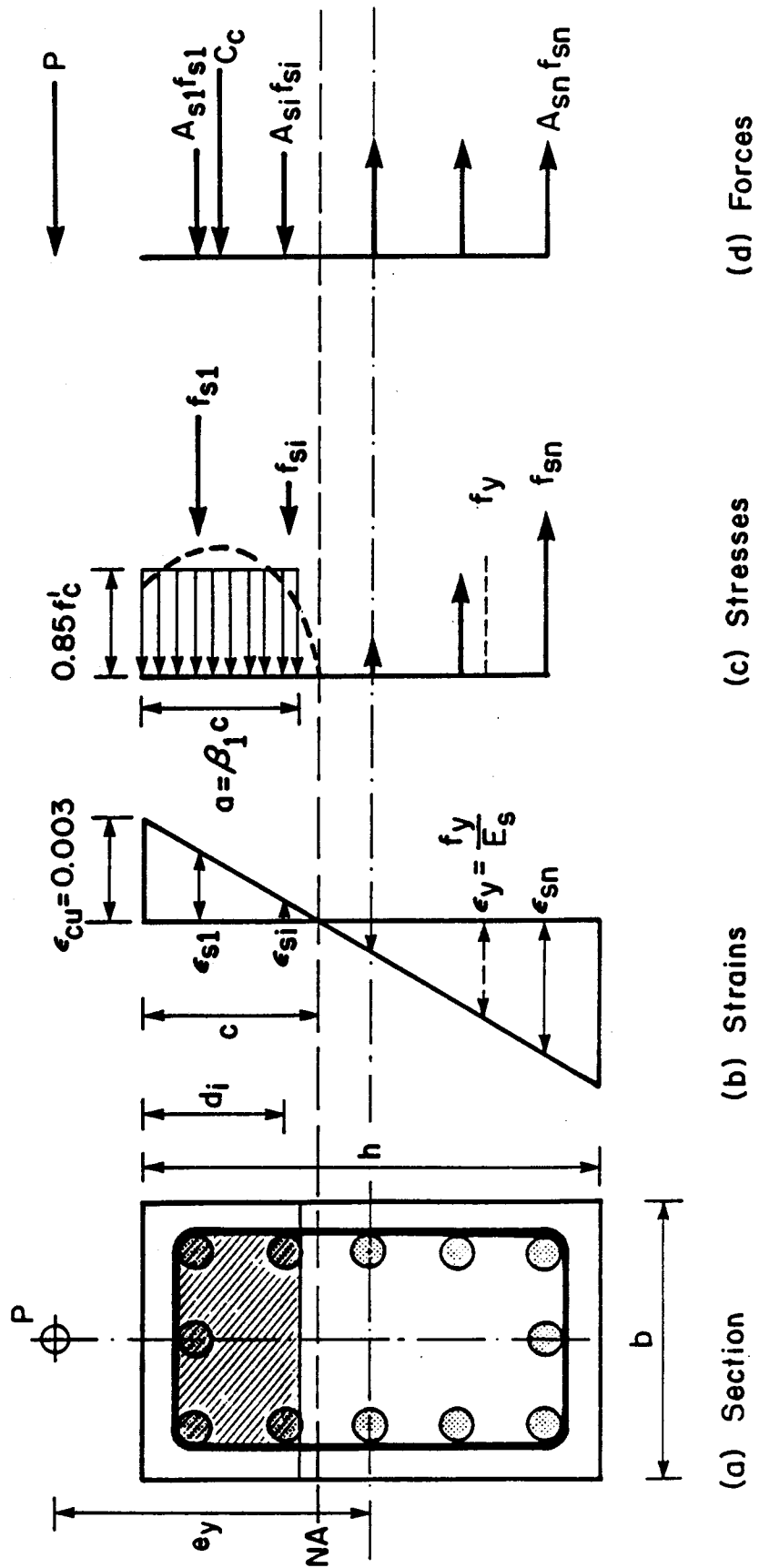

Figure 4.5 Strength Capacity of Uniaxially Loaded Column

equal to or just greater than the applied factored axial load is located, otherwise the section is incremented.

The position of the neutral axis located at depth  $c$ , as indicated in Fig. 4.6, is initially assumed to fall between the two possible limits  $c_u$  and  $c_l$ . The upper limit  $c_u$  corresponds to the case where the depth of the compression stress block is equal to the depth of the column, and the lower limit  $c_l$  corresponds to the pure axial tension case. The axial load capacity is then computed and compared to the applied factored axial load. As shown in Fig. 4.6, depending on whether the applied factored load is greater than the computed axial load capacity, a new position of the neutral axis is located halfway between the previous location and the appropriate limit  $c_u$  and  $c_l$ . Note that at this time, again depending on the relative values of the applied and computed axial load capacity, the position of either  $c_u$  or  $c_l$  is altered to correspond to the previous location of the neutral axis. In this way the location of the neutral axis converges to the location where the computed and the applied axial load capacities are within a prescribed limit (which in *COLUMN* is set to  $+ 0.0025 \times P_f$ ). If convergence is not possible the computed capacity is always less than the applied axial load and the section must be incremented.

For any position of the neutral axis, the axial load is computed as follows.

$$P_r = \phi_c 0.85 f'_c A_c + \phi_s \sum_{i=1}^n f_{si} A_{si} \quad [4.5]$$

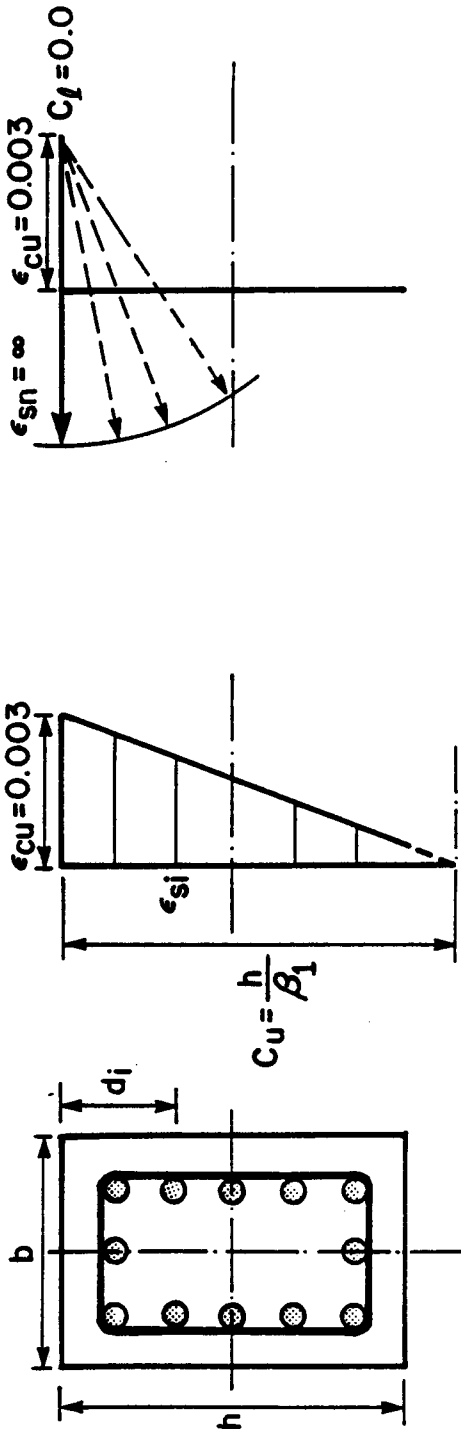

(a) Section

(b) Initial Limit on  $C_u$

(c) Initial Limit on  $C_e$

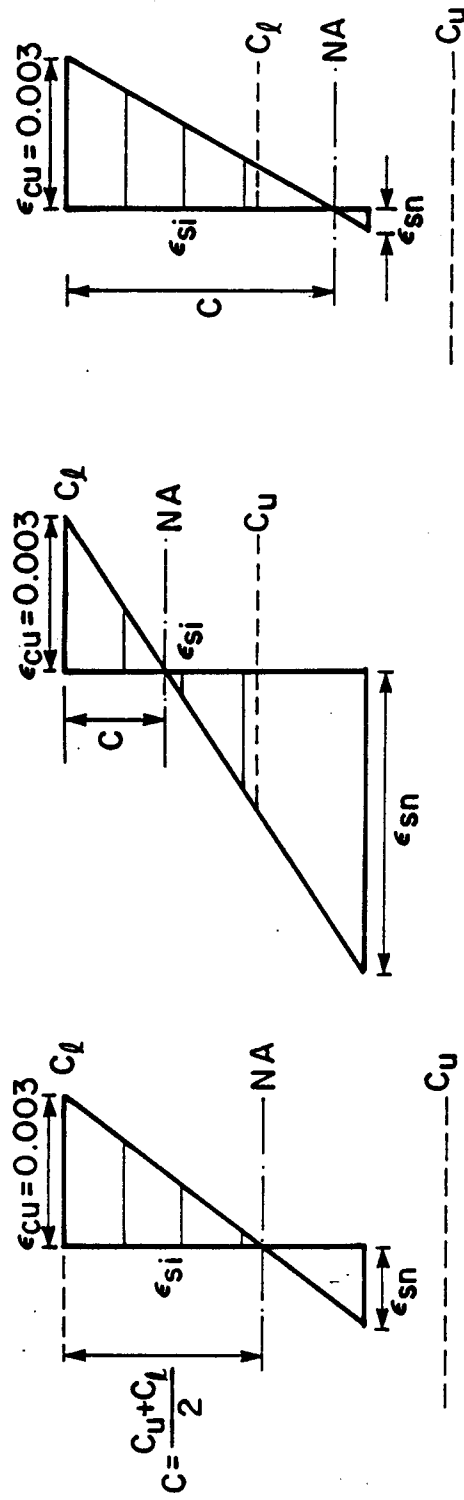

(d) First Trial NA

(e) Axial Load Capacity  $>$  Applied Load

(f) Axial Load Capacity  $<$  Applied Load

Figure 4.6 Interval Halving Technique for Location of NA



in the case of CAN3-A23.3-M84 and

$$P_n = \phi(0.85f'_cA_c + \sum_{i=1}^n f_{s_i}A_{s_i}) \quad [4.6]$$

for the case of CAN3-A23.3-M77 and ACI 318-83.  $P_r$  and  $P_n$  are the factored axial load resistances and  $A_c$  is the area of concrete in compression defined by:

$$A_c = ab$$

in the case of a rectangular or square section and;

$$A_c = h^2 \left[ \frac{\theta - \sin\theta\cos\theta}{4} \right]$$

where

$$\theta = \cos^{-1} \left[ \frac{h/2 - a}{h/2} \right]$$

in the case of circular when  $a \leq h/2$  (Fig. 4.7) and

$$\theta = 180 - \psi$$

where

$$\psi = \cos^{-1} \left[ \frac{a - h/2}{h/2} \right]$$

in the case of a circular section with  $a > h/2$  (Fig. 4.8).  $\phi_c$  and  $\phi_s$  are the resistance factors for concrete and steel respectively and  $\phi$  is the strength reduction factor. The capacity reduction factor  $\phi$  is modified as described in Section A.8 of Appendix A. If the sign of the stress in

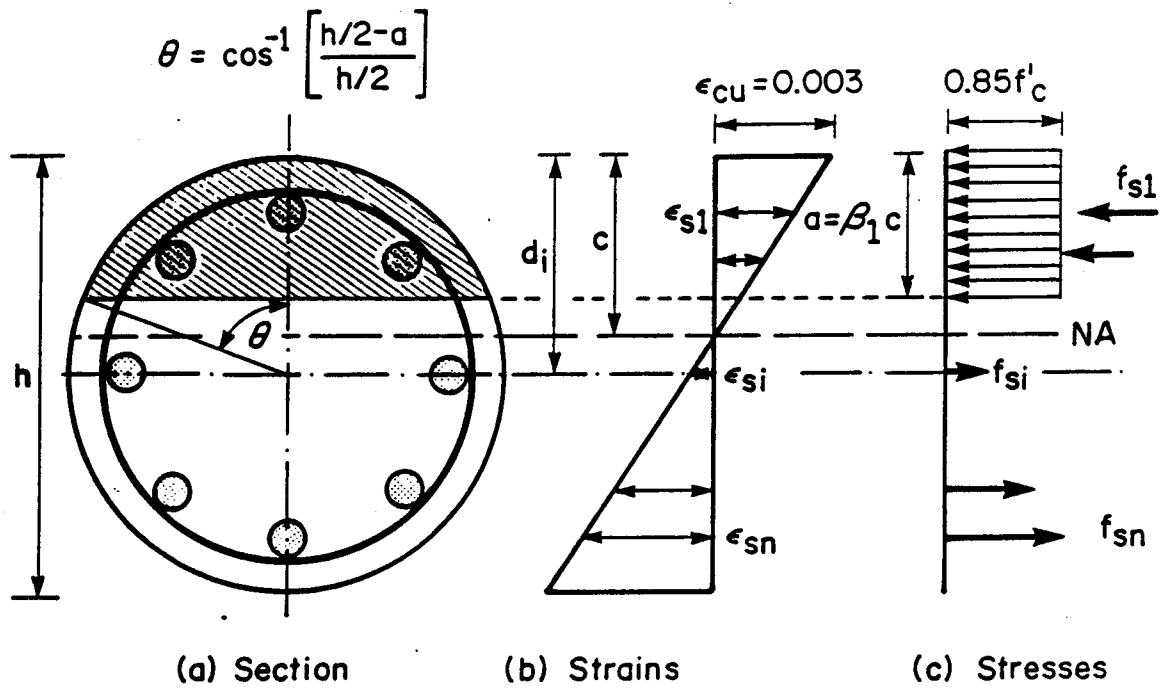

Figure 4.7 Compression Zone for Circular Section ( $a \leq h/2$ )

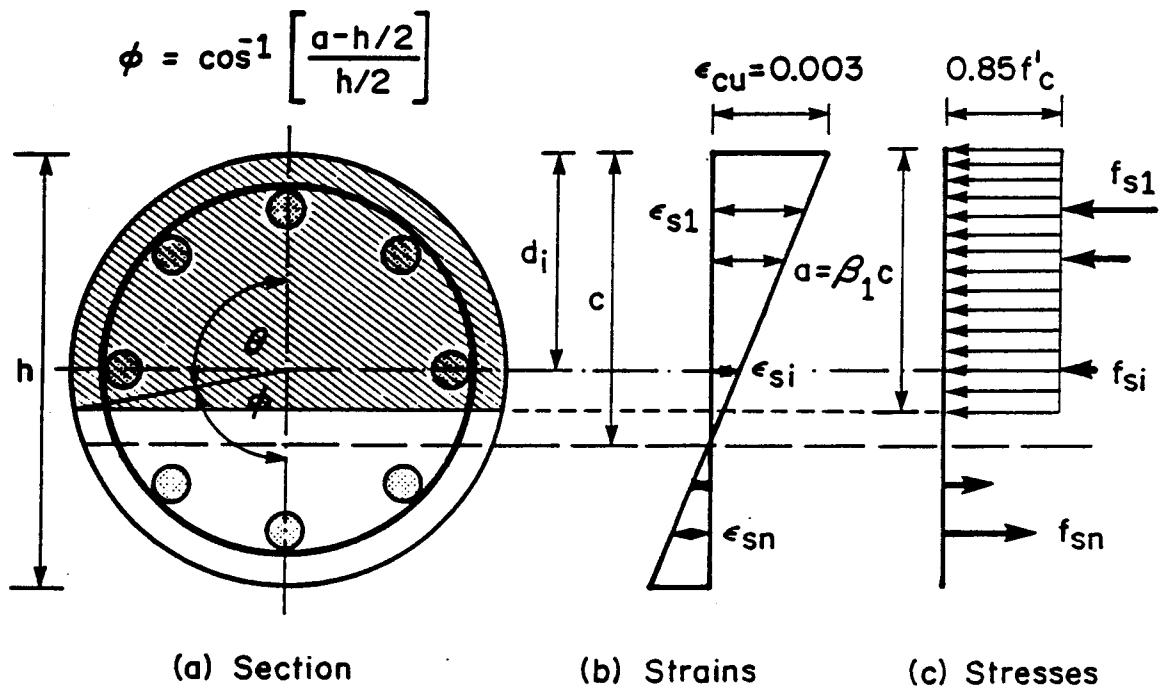

Figure 4.8 Compression Zone for Circular Section ( $a > h/2$ )

steel is negative, then the steel is in tension; otherwise, in compression. If steel is in compression, the force due to the area of concrete displaced by the steel in compression is subtracted, as this has already been accounted for in the computation of the force due to the total area of concrete in compression.

If a resisting axial load equal to the factored axial load is not possible, the trial section is modified as described in Section 4.3.2. When the neutral axis is located so that the axial load resistance is equal to the applied load the corresponding resisting moment of the section is computed using:

$$M_r = \phi_c 0.85 f'_c a_c \bar{y} + \phi_s \sum_{i=1}^n f_{si} A_{si} (h/2 - d_i) \quad [4.7]$$

in the case of CAN3-A23.3-M84 and

$$M_r = \phi [0.85 f'_c a_c \bar{y} + \sum_{i=1}^n f_{si} A_{si} (h/2 - d_i)] \quad [4.8]$$

in the case of CAN3-A23.3-M77 and ACI 318-83, where

$$a_c \bar{y} = ab(h/2 - a)$$

for a rectangular or a square section (Fig. 4.5), and

$$a_c \bar{y} = h^3 \left[ \frac{\sin^3 \theta}{12} \right]$$

in the case of a circular section (Fig. 4.7 and 4.8).

If the resisting moment  $M_r$  is greater or equal to the applied magnified factored moment  $M_c$  then the section is adequate; otherwise, the section has to be modified as described in Section 4.3.2. and the program backtracks so that the process from the computation of slenderness effects described in Section 4.4.1, to the evaluation of strength capacity is repeated until an adequate section is found. If the program is being used in check mode a message indicating whether the column is adequate or inadequate in strength is printed.

The above procedure ensures that the point on the load-moment interaction diagram represented by the coordinates  $M_c$  and  $P_f$ , the factored loads, always lies within and therefore to the right of the failure curve (Fig. 4.9).

The reader is referred to Appendix A for a complete discussion on the interpretation and implementation of code heuristics.

#### 4.4.3 Biaxial Bending

In a biaxially loaded column, determining the location of the neutral axis that satisfies equilibrium is not as simple and straightforward as in the uniaxially loaded case. The neutral axis is not usually normal to either of the principal axis or to the resultant eccentricity and therefore is dependent on two unknown variables; the angle

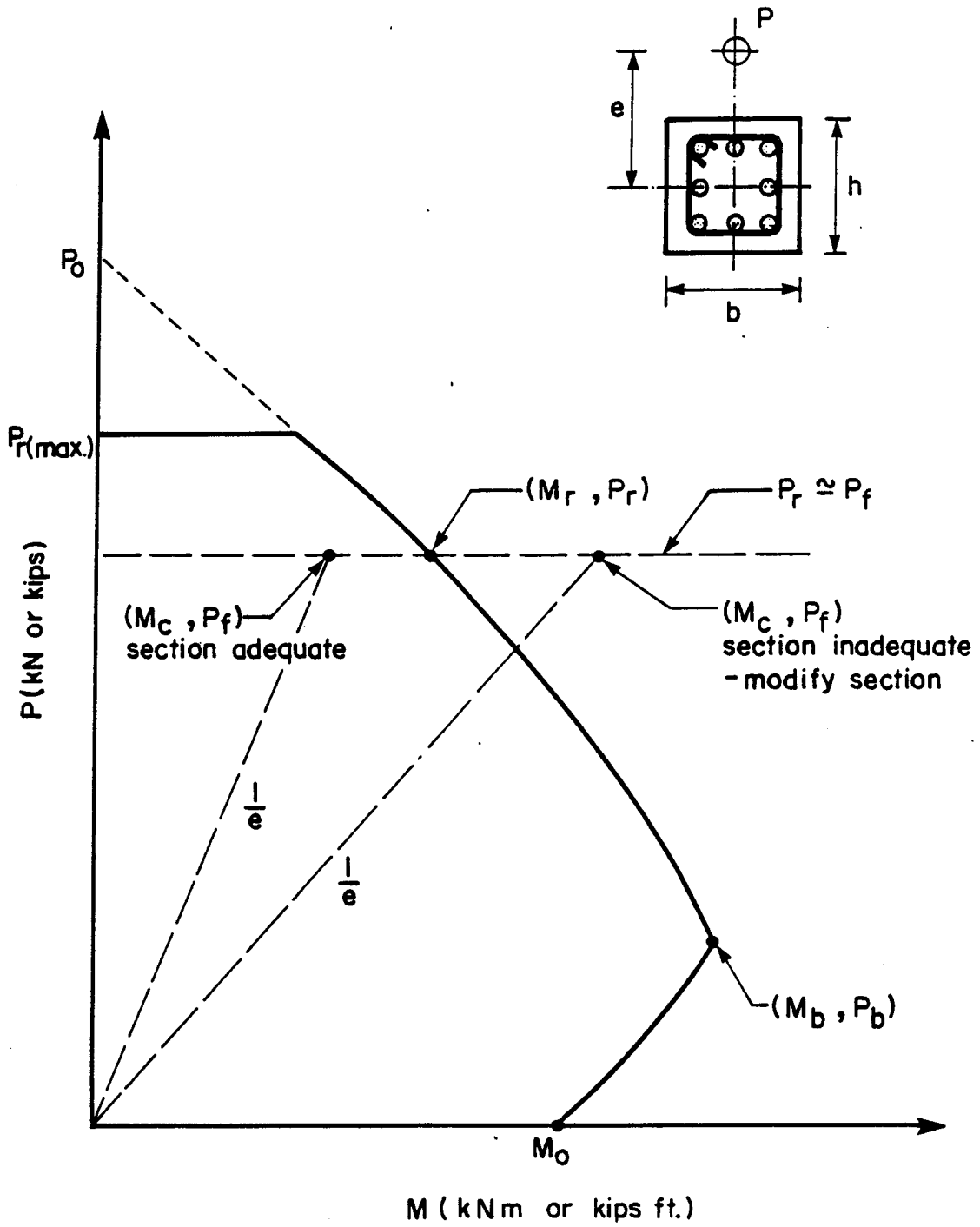

Figure 4.9 Evaluation of Strength Capacity

of inclination with either reference axis and the depth. A trial and error procedure which successively corrects the position of the neutral axis until the section capacity approaches the required value, involves a numerous amount of iterations and therefore is time consuming even for use on a computer.

To simplify the approach, there are available various approximate design methods that deal with biaxial bending, that for practical design purposes have proved to be reasonably adequate. Three methods that are commonly used include:

1. Bresler's Reciprocal Method
2. Load Contour Method
3. Equivalent Eccentricity Method

The procedure implemented in *COLUMN* to verify whether the selected design is adequate for strength, is the Equivalent Eccentricity approach. In this method, a biaxial bending situation is reduced to one with bending about one of the major axes. This is accomplished by replacing the eccentricities of the load  $P$  ( $e_x$  and  $e_y$ ) by an equivalent uniaxial eccentricity  $e_o$  as follows.

In the case where:

$$\frac{e_x}{c_x} \geq \frac{e_y}{c_y}$$

the inclined bending is simulated by uniaxial bending about the  $y$ -axis with the axial load  $P$  acting at an equivalent

eccentricity  $e_{ox}$  computed by:

$$e_{ox} = e_x + ae_y \frac{c_x}{c_y} \quad [4.9]$$

On the other hand, if:

$$\frac{e_y}{c_y} > \frac{e_x}{c_x}$$

the loading is replaced by the axial load  $P$  acting at an equivalent eccentricity about the x-axis  $e_{oy}$  described by:

$$e_{oy} = e_y + ae_x \frac{c_y}{c_x} \quad [4.10]$$

For the case when,

$$\frac{P}{A_g f'_c} \leq 0.4$$

$$a = \left[ 0.5 + \frac{P}{A_g f'_c} \right] \left[ \frac{f_y + 300}{700} \right] \geq 0.6 \quad [4.11]$$

and for,

$$\frac{P}{A_g f'_c} \geq 0.4$$

$$a = \left[ 1.3 - \frac{P}{A_g f'_c} \right] \left[ \frac{f_y + 300}{700} \right] \geq 0.5 \quad [4.12]$$

Having reduced the biaxially loaded situation into a uniaxially loaded one, the strength adequacy of the column section is evaluated using the same solution strategy that utilizes the interval halving procedure as described in

#### Sections 4.4.2.

This method although simple in its approach produces feasible designs that are representative of those used in practice. Table 4.2 gives an indication of the accuracy of the method when compared to the Bresler's Reciprocal approach. These values were computed on the basis of 131 column tests.

It is important to note that the type of procedure used in tackling biaxial bending problems is not a main issue within the context of this research. The prime objective is to study the manner in which knowledge required in selecting feasible designs could be incorporated in a CAD environment. It is evident that the accuracy of the designs depends on the sophistication of the design method adopted. However, as already mentioned, refining the method for the strength analysis does not always mean that the resulting overall design process is a consistent one. In spite of this, any type of design solution strategy can be incorporated, since the built-in knowledge for the design process is independent of the level of sophistication of the analysis method used.



Table 4.2 Accuracy of the Equivalent Eccentricity Method

		EQUIVALENT ECCENTRICITY APPROACH	BRESLER'S RECIPROCAL METHOD
COMPRESSION FAILURE	<u>mean test</u> calculated	1.177	1.150
	coefficient of variation	0.112	0.119
TENSION FAILURE	<u>mean test</u> calculated	1.125	1.185
	coefficient of variation	0.129	0.100

## 5. DESIGN EXAMPLES

### 5.1 Introduction

In this chapter the use and application of *COLUMN* are illustrated. Three design examples are presented to demonstrate the general features and to evaluate the designs produced by the system. The user specified input data and the system's printed output are also presented. For clarity, the examples are executed in batch mode. The procedure for entering data and the control commands are described in detail in the USER'S MANUAL in Appendix A. The output, produced by *COLUMN* is composed of two parts.

1. An echo check of the input design parameters including default values assigned to the unspecified data by the program.
2. Design information on the selected section dimensions and reinforcement together with additional design comments that are specific to the particular problem.

### 5.2 Example 1 - Tied Column Design

The data of this example is taken from Example 7.1 in 'Concrete Design Handbook' (CPCA, 1985). Design a tied column to support a factored axial load of 2630 kN and factored moment about the x-axis of 100 kNm. The column is braced against sidesway and has an unsupported length  $l_u = 3400$  mm. Assume condition elastic + at both the top and bottom of the column so that from Fig. C1, Appendix C of

CAN3-A23.3-M84 the value of  $k = 0.9$ . The material properties for this design are  $f'_c = 40$  MPa and  $f_y = 400$  MPa. Type S concrete is used and the concrete cover to No.10 ties is 40 mm.

The shape of cross section selected by *COLUMN* is square and the bars are distributed on all faces since the predominate loading action is due to the compressive load. The design suggested by *COLUMN* is identical to that given in the Handbook.

```

TIED COLUMN DESIGN
A2 at 4th FLOOR
D,C84,T
40.,400.,0.,
0.,
S
R
0.,0.,0.,
0.,0.,0.,
D,T
0.,
0,0,0,
0,0,0
F
2630.,0.,
100.,0.,0.,0.,
0.,0.,0.,0.,
1,0.90,3400.,
1,0.90,3400.,

```

Input for Example 1

```

*****
*
*                               COLUMN                               *
*
*
*   Column version 1.0 (Jul/1987) - knowledge-based computer      *
*   program for the design and analysis of reinforced             *
*   concrete columns                                             *
*
*   Developed at The Department of Civil Engineering              *
*   The University of Alberta Edmonton, Alberta, Canada          *
*   by: Alexander Bezzina & Sidney H. Simmonds                  *
*
*****

```

PROJECT: TIED COLUMN DESIGN      COLUMN ID: A2 at 4th FLOOR

MODE: DESIGN MODE      CODE: CSA CAN3-A23.3-M84

MATERIAL PROPERTIES:

<u>concrete:</u>	<u>steel:</u>
f c = 40.0 N/sq.mm	fy (long.) = 400.0 N/sq.mm
Wt. = 2400.0 kg/cu.m	fy (lat.) = .0 N/sq.mm
Ec = 31975.4 N/sq.mm	Es = 200000.0 N/sq.mm
type = SEMI-LOW DENSITY	

SECTION DATA:

<u>concrete section:</u>	<u>reinforcement:</u>
shape = RECTANGULAR	type = TIED
cx = .0 mm	reinf. pattern = UNSPECIFIED
cy = .0 mm	splice type = TANGENTIAL
R = .0	max. reinf. ratio = .030
cover = .0 mm	max. no. of bars =
cx incr. = .0 mm	no. bars x-face =
cy incr. = .0 mm	no. bars y-face =
	max. bar size = #35
	min. bar size = #15

COLUMN DATA:

type = BRACED ABOUT X-AXIS	type = BRACED ABOUT Y-AXIS
lx = 3400.0 mm	ly = 3400.0 mm
kx = .90	ky = .90

INPUT LOADING:

type = FACTORED		
<u>axial loads:</u>	<u>moments:</u>	
Pd = 2630.0 kN	top end:	bottom end:
Pl = .0 kN	Mxd = 100.0 kN.m	Mxd = .0 kN.m
	Myd = .0 kN.m	Myd = .0 kN.m
	Mxl = .0 kN.m	Mxl = .0 kN.m
	Myl = .0 kN.m	Myl = .0 kN.m

Output for Example 1

## DESIGN - COLUMN ID: A2 at 4th FLOOR

\*\*\*\*\*

DESIGN FACTORED LOADS:

P = 2630.0 kN  
 Mx = 100.0 kN.m  
 My = .0 kN.m

SLENDERNESS RATIOS:

(kl/r) - x = 30.3  
 (kl/r) - y = .0

COLUMN DESIGN:

concrete section:  
 cx = 350.0 mm  
 cy = 350.0 mm  
 cover = 40.0 mm

reinforcement:  
 no. bars x-face = 2 - #30  
 no. bars y-face =  
 total no. of bars = 4 - #30  
 reinf. ratio = .023  
 tie sets - #10 @ 350.0 mm

ADDITIONAL DESIGN COMMENTS:

COLUMN DEFLECTS IN SINGLE CURVATURE ABOUT X-AXIS

SLENDERNESS EFFECTS ABOUT X-AXIS DUE TO  
 STABILTY MAY BE NEGLECTED

TANGENTIAL SPLICES CAN BE USED.

CLEAR SPACING OF BARS ON THE X-FACE = 187.6 mm

CLEAR SPACING OF BARS ON THE Y-FACE = 187.6 mm

Output for Example 1 (contd)

### 5.3 Example 2 - Circular Spiral Column

This is example 7.2(b) in 'Concrete Design Handbook' (CPCA, 1985). Design a circular spiral column for a  $P_f = 4560$  kN and  $M_f = 20$  kNm, in accordance with CAN3-A23.3-M84. The material properties for this project are  $f'_c = 40$  MPa,  $f_y = 400$  MPa, and  $f_{sy} = 400$  MPa. The unsupported length of the column  $l_u = 3600$  mm and as in the previous example  $k = 0.9$ .

The diameter of the column section selected by the program is 500 mm, which is identical to that used in the Handbook. However, the percentage reinforcement selected by *COLUMN* is 2.5% as compared to 2.14% given in the source example. *COLUMN*, designs for a moment of 136.8 kNm computed from the minimum eccentricity requirement

$$e = (15 \text{ mm} + 0.3h) = 30 \text{ mm}$$

$$M_f = P_f \times e = 136.8 \text{ kNm}$$

rather than the entered moment of 20 kNm. This minimum eccentricity requirement is overlooked in the example given in the Handbook.

CIRCULAR SPIRAL COLUMN  
B2 at 3rd FLOOR  
D,C84,S  
40.,400.,400.,  
0.,  
N  
C  
0.,0.,0.,  
0.,0.,0.,  
D,R  
0.,  
0,0,0,  
0,0,0  
F  
4560.,0.,  
20.,0.,0.,0.,  
0.,0.,0.,0.,  
1,0.90,3600.,  
1,0.90,3600.,

Input for Example 2

```

*****
*
*                               COLUMN
*
*
*   Column version 1.0 (Jul/1987) - knowledge-based computer
*   program for the design and analysis of reinforced
*   concrete columns
*
*   Developed at The Department of Civil Engineering
*   The University of Alberta Edmonton, Alberta, Canada
*   by: Alexander Bezzina & Sidney H. Simmonds
*
*****

```

PROJECT: CIRCULAR SPIRAL COLUMN    COLUMN ID: B2 at 3rd FLOOR

MODE: DESIGN MODE

CODE: CSA CAN3-A23.3-M84

MATERIAL PROPERTIES:

concrete:

f c = 40.0 N/sq.mm  
 Wt. = 2400.0 kg/cu.m  
 Ec = 31975.4 N/sq.mm  
 type = NORMAL DENSITY

steel:

fy (long.) = 400.0 N/sq.mm  
 fy (lat.) = 400.0 N/sq.mm  
 Es = 200000.0 N/sq.mm

SECTION DATA:

concrete section:

shape = CIRCULAR  
 cx = .0 mm  
 cy = .0 mm  
 R = .0  
 cover = .0 mm  
 cx incr. = .0 mm  
 cy incr. = .0 mm

reinforcement:

type = SPIRAL  
 reinf. pattern = CIRCULAR  
 splice type = RADIAL  
 max. reinf. ratio = .030  
 max. no. of bars =  
 no. bars x-face =  
 no. bars y-face =  
 max. bar size = #35  
 min. bar size = #15

COLUMN DATA:

type = BRACED ABOUT X-AXIS  
 lx = 3600.0 mm  
 kx = .90

type = BRACED ABOUT Y-AXIS  
 ly = 3600.0 mm  
 ky = .90

INPUT LOADING:

type = FACTORED

axial loads:

Pd = 4560.0 kN  
 Pl = .0 kN

moments:

top end:

Mxd = 20.0 kN.m  
 Myd = .0 kN.m  
 Mxl = .0 kN.m  
 Myl = .0 kN.m

bottom end:

Mxd = .0 kN.m  
 Myd = .0 kN.m  
 Mxl = .0 kN.m  
 Myl = .0 kN.m

Output for Example 2



DESIGN - COLUMN ID: B2 at 3rd FLOOR

\*\*\*\*\*

DESIGN FACTORED LOADS:

P = 4560.0 kN  
 Mx = 136.8 kN.m  
 My = .0 kN.m

SLENDERNES RATIO:

(kl/r) - x = 25.9  
 (kl/r) - y = .0

COLUMN DESIGN:

concrete section:  
 cx = 500.0 mm  
 cy = .0 mm  
 cover = 40.0 mm

reinforcement:  
 no. bars x-face = 10 - #25  
 no. bars y-face =  
 total no. of bars = 10 - #25  
 reinf. ratio = .025  
 spirals - #10 @ pitch - 50.0 mm  
 no. of spacers = 2

ADDITIONAL DESIGN COMMENTS:

COLUMN DEFLECTS IN SINGLE CURVATURE ABOUT X-AXIS

MINIMUM ECCENTRICITY ABOUT X-AXIS GOVERNS  
 MINIMUM MOMENT ABOUT X-AXIS = 136.8 kN.m

SLENDERNES EFFECTS ABOUT X-AXIS DUE TO  
 STABILTY MAY BE NEGLECTED

RADIAL SPLICES CAN BE USED

Output for Example 2 (contd)

#### 5.4 Example 3 - Biaxial Bending

The purpose of this example is to illustrate the different designs that result when additional constraints are imposed by the engineer. Consider the design of a braced tied column in accordance with CAN3-A23.3-M84 for the following factored loading:

$$P = 1400.0 \text{ kN}$$

$$M_x = 252.0 \text{ kNm}$$

$$M_y = 560.0 \text{ kNm}$$

For all cases use  $f'_c = 30 \text{ MPa}$ ,  $f_y = 400 \text{ MPa}$ , No. 10 ties with 40 mm cover and a dimension increment of 20 mm. The additional constraints imposed in selecting the column section are:

- a. no additional constraints,
- b. section specified as square but no restrictions imposed on selecting reinforcement and
- c. section specified as square with equal reinforcement on all four faces.

It is observed that the moment  $M_y$  is large compared to  $M_x$  and the more efficient solution of elongating the section in the x-direction and placing the reinforcement only in the x-faces is selected when no additional constraints are imposed. This resulted in 17% less concrete and 25% less reinforcement than case(c) when a square section with equal reinforcement on all faces was specified. When only a square

section was specified the reinforcement was placed on only two faces as the more efficient arrangement. Of course, if the difference in the applied moments had been less, the difference in solution due to the constraints imposed would be less, since if the applied moments were equal a square section with reinforcement on all faces would have been selected for the no additional constraint case.

**BIAXIAL BENDING (a)**  
 A1 at 2nd FLOOR  
 D,C84,T  
 30.,,400.,,0.,,  
 0.,,  
 N  
 R  
 0.,,0.,,0.,,  
 20.,,20.,,0.,,  
 D,R  
 0.,,  
 0,0,0,  
 0,0,0,  
 0,0,0,  
 F  
 1400.,,0.,,  
 252.,,0.,,560.,,0.,,  
 0.,,0.,,0.,,  
 1,0.75,4000.,,  
 1,0.75,4000.,,

**BIAXIAL BENDING (b)**  
 A1 at 2nd FLOOR  
 D,C84,T  
 30.,,400.,,0.,,  
 0.,,  
 N  
 S  
 0.,,0.,,0.,,  
 20.,,20.,,0.,,  
 D,T  
 0.,,  
 0,0,0,  
 0,0,0,  
 0,0,0,  
 F  
 1400.,,0.,,  
 252.,,0.,,560.,,0.,,  
 0.,,0.,,0.,,  
 1,0.75,4000.,,  
 1,0.75,4000.,,

**BIAXIAL BENDING (c)**  
 A1 at 2nd FLOOR  
 D,C84,T  
 30.,,400.,,0.,,  
 0.,,  
 N  
 S  
 0.,,0.,,0.,,  
 20.,,20.,,0.,,  
 B,T  
 0.,,  
 0,0,0,  
 0,0,0,  
 0,0,0,  
 F  
 1400.,,0.,,  
 252.,,0.,,560.,,0.,,  
 0.,,0.,,0.,,  
 1,0.75,4000.,,  
 1,0.75,4000.,,

Input for Example 3(a), 3(b), 3(c)

```

*****
*
*                               COLUMN
*
*
*   Column version 1.0 (Jul/1987) - knowledge-based computer
*   program for the design and analysis of reinforced
*   concrete columns
*
*   Developed at The Department of Civil Engineering
*   The University of Alberta Edmonton, Alberta, Canada
*   by: Alexander Bezzina & Sidney H. Simmonds
*
*****

```

PROJECT: BIAKIAL BENDING (a)      COLUMN ID: A1 at 2nd FLOOR

MODE: DESIGN MODE      CODE: CSA CAN3-A23.3-M84

MATERIAL PROPERTIES:

<u>concrete:</u>	<u>steel:</u>
f c = 30.0 N/sq.mm	fy (long.) = 400.0 N/sq.mm
Wt. = 2400.0 kg/cu.m	fy (lat.) = .0 N/sq.mm
Ec = 27691.5 N/sq.mm	Es = 200000.0 N/sq.mm
type = NORMAL DENSITY	

SECTION DATA:

<u>concrete section:</u>	<u>reinforcement:</u>
shape = RECTANGULAR	type = TIED
cx = .0 mm	reinf. pattern = UNSPECIFIED
cy = .0 mm	splice type = RADIAL
R = .0	max. reinf. ratio = .030
cover = .0 mm	max. no. of bars =
cx incr. = 20.0 mm	no. bars x-face =
cy incr. = 20.0 mm	no. bars y-face =
	max. bar size = #35
	min. bar size = #15

COLUMN DATA:

type = BRACED ABOUT X-AXIS	type = BRACED ABOUT Y-AXIS
lx = 4000.0 mm	ly = 4000.0 mm
kx = .75	ky = .75

INPUT LOADING:

type = FACTORED		
<u>axial loads:</u>	<u>moments:</u>	
Pd = 1400.0 kN	top end:	bottom end:
P1 = .0 kN	Mxd = 252.0 kN.m	Mxd = .0 kN.m
	Myd = 560.0 kN.m	Myd = .0 kN.m
	Mxl = .0 kN.m	Mxl = .0 kN.m
	Myl = .0 kN.m	Myl = .0 kN.m

Output for Example 3(a)

**DESIGN - COLUMN ID: A1 at 2nd FLOOR**

\*\*\*\*\*

**DESIGN FACTORED LOADS:**

P = 1400.0 kN  
 Mx = 252.0 kN.m  
 My = 560.0 kN.m

**SLENDERNES RATIO:**

(kl/r) - x = 24.7  
 (kl/r) - y = 16.8

**COLUMN DESIGN:****concrete section:**

cx = 620.0 mm  
 cy = 420.0 mm  
 cover = 40.0 mm

**reinforcement:**

no. bars x-face = 3 - #35  
 no. bars y-face = 6 - #35  
 total no. of bars = 6 - #35  
 reinf. ratio = .023  
 tie sets - #10 @ 420.0 mm

**ADDITIONAL DESIGN COMMENTS:**

COLUMN DEFLECTS IN SINGLE CURVATURE ABOUT Y-AXIS

COLUMN DEFLECTS IN SINGLE CURVATURE ABOUT X-AXIS

SLENDERNES EFFECTS ABOUT X-AXIS DUE TO  
 STABILTY MAY BE NEGLECTED

SLENDERNES EFFECTS ABOUT Y-AXIS DUE TO  
 STABILTY MAY BE NEGLECTED

RADIAL SPLICES CAN BE USED

CLEAR SPACING OF BARS ON THE X-FACE = 105.1 mm

CLEAR SPACING OF BARS ON THE Y-FACE = 446.0 mm

Output for Example 3(a) (contd)

```

*****
*
*                               COLUMN
*
*
*   Column version 1.0 (Jul/1987) - knowledge-based computer
*   program for the design and analysis of reinforced
*   concrete columns
*
*   Developed at The Department of Civil Engineering
*   The University of Alberta Edmonton, Alberta, Canada
*   by: Alexander Bezzina & Sidney H. Simmonds
*
*****

```

PROJECT: BIAXIAL BENDING (b)      COLUMN ID: A1 at 2nd FLOOR

MODE: DESIGN MODE      CODE: CSA CAN3-A23.3-M84

MATERIAL PROPERTIES:

<u>concrete:</u>	<u>steel:</u>
f c = 30.0 N/sq.mm	fy (long.) = 400.0 N/sq.mm
Wt. = 2400.0 kg/cu.m	fy (lat.) = .0 N/sq.mm
Ec = 27691.5 N/sq.mm	Es = 200000.0 N/sq.mm
type = NORMAL DENSITY	

SECTION DATA:

<u>concrete section:</u>	<u>reinforcement:</u>
shape = SQUARE	type = TIED
cx = .0 mm	reinf. pattern = UNSPECIFIED
cy = .0 mm	splice type = TANGENTIAL
R = .0	max. reinf. ratio = .030
cover = .0 mm	max. no. of bars =
cx incr. = 20.0 mm	no. bars x-face =
cy incr. = 20.0 mm	no. bars y-face =
	max. bar size = #35
	min. bar size = #15

COLUMN DATA:

type = BRACED ABOUT X-AXIS	type = BRACED ABOUT Y-AXIS
lx = 4000.0 mm	ly = 4000.0 mm
kx = .75	ky = .75

INPUT LOADING:

type = FACTORED	
<u>axial loads:</u>	<u>moments:</u>
Pd = 1400.0 kN	top end:
Pl = .0 kN	bottom end:
	Mxd = 252.0 kN.m      Mxd = .0 kN.m
	Myd = 560.0 kN.m      Myd = .0 kN.m
	Mxl = .0 kN.m      Mxl = .0 kN.m
	Myl = .0 kN.m      Myl = .0 kN.m

Output for Example 3(b)

DESIGN - COLUMN ID: A1 at 2nd FLOOR

\*\*\*\*\*

DESIGN FACTORED LOADS:

P = 1400.0 kN  
 Mx = 252.0 kN.m  
 My = 560.0 kN.m

SLENDERNESS RATIOS:

(kl/r) - x = 20.0  
 (kl/r) - y = 20.0

COLUMN DESIGN:

concrete section:  
 cx = 520.0 mm  
 cy = 520.0 mm  
 cover = 40.0 mm

reinforcement:  
 no. bars x-face = 4 - #35  
 no. bars y-face =  
 total no. of bars = 8 - #35  
 reinf. ratio = .030  
 tie sets - #10 @ 520.0 mm

ADDITIONAL DESIGN COMMENTS:

COLUMN DEFLECTS IN SINGLE CURVATURE ABOUT Y-AXIS

COLUMN DEFLECTS IN SINGLE CURVATURE ABOUT X-AXIS

SLENDERNESS EFFECTS ABOUT X-AXIS DUE TO  
 STABILTY MAY BE NEGLECTED

SLENDERNESS EFFECTS ABOUT Y-AXIS DUE TO  
 STABILTY MAY BE NEGLECTED

TANGENTIAL SPLICES CAN BE USED

CLEAR SPACING OF BARS ON THE X-FACE = 91.5 mm

CLEAR SPACING OF BARS ON THE Y-FACE = 346.0 mm

Output for Example 3(b) (contd)



```

*****
*
*                               COLUMN
*
*
*   Column version 1.0 (Jul/1987) - knowledge-based computer
*   program for the design and analysis of reinforced
*   concrete columns
*
*   Developed at The Department of Civil Engineering
*   The University of Alberta Edmonton, Alberta, Canada
*   by: Alexander Bezzina & Sidney H. Simmonds
*
*****

```

PROJECT: BIAXIAL BENDING (c)      COLUMN ID: A1 at 2nd FLOOR

MODE: DESIGN MODE

CODE: CSA CAN3-A23.3-M84

MATERIAL PROPERTIES:

concrete:

f c = 30.0 N/sq.mm  
 wt. = 2400.0 kg/cu.m  
 Ec = 27691.5 N/sq.mm  
 type = NORMAL DENSITY

steel:

fy (long.) = 400.0 N/sq.mm  
 fy (lat.) = .0 N/sq.mm  
 Es = 200000.0 N/sq.mm

SECTION DATA:

concrete section:

shape = SQUARE  
 cx = .0 mm  
 cy = .0 mm  
 R = .0  
 cover = .0 mm  
 cx incr. = 20.0 mm  
 cy incr. = 20.0 mm

reinforcement:

type = TIED  
 reinf. pattern = BOTH FACES  
 splice type = TANGENTIAL  
 max. reinf. ratio = .030  
 max. no. of bars =  
 no. bars x-face =  
 no. bars y-face =  
 max. bar size = #35  
 min. bar size = #15

COLUMN DATA:

type = BRACED ABOUT X-AXIS  
 lx = 4000.0 mm  
 kx = .75

type = BRACED ABOUT Y-AXIS  
 ly = 4000.0 mm  
 ky = .75

INPUT LOADING:

type = FACTORED

axial loads:

Pd = 1400.0 kN  
 Pl = .0 kN

moments:

<u>top end:</u>		<u>bottom end:</u>	
Mxd =	252.0 kN.m	Mxd =	.0 kN.m
Myd =	560.0 kN.m	Myd =	.0 kN.m
Mxl =	.0 kN.m	Mxl =	.0 kN.m
Myl =	.0 kN.m	Myl =	.0 kN.m

Output for Example 3(c)

DESIGN - COLUMN ID: A1 at 2nd FLOOR

\*\*\*\*\*

DESIGN FACTORED LOADS:

P = 1400.0 kN  
 Mx = 252.0 kN.m  
 My = 560.0 kN.m

SLENDERNESS RATIOS:

(kl/r) - x = 18.6  
 (kl/r) - y = 18.6

COLUMN DESIGN:

concrete section:  
 cx = 560.0 mm  
 cy = 560.0 mm  
 cover = 40.0 mm

reinforcement:  
 no. bars x-face = 3 - #35  
 no. bars y-face = 1 - #35  
 total no. of bars = 8 - #35  
 reinf. ratio = .026  
 tie sets - #10 @ 542.4 mm

ADDITIONAL DESIGN COMMENTS:

COLUMN DEFLECTS IN SINGLE CURVATURE ABOUT Y-AXIS

COLUMN DEFLECTS IN SINGLE CURVATURE ABOUT X-AXIS

SLENDERNESS EFFECTS ABOUT X-AXIS DUE TO  
 STABILTY MAY BE NEGLECTED

SLENDERNESS EFFECTS ABOUT Y-AXIS DUE TO  
 STABILTY MAY BE NEGLECTED

TANGENTIAL SPLICES CAN BE USED

CLEAR SPACING OF BARS ON THE X-FACE = 175.2 mm

CLEAR SPACING OF BARS ON THE Y-FACE = 175.2 mm

Output for Example 3(c) (contd)

## 5.5 Conclusions

The examples presented cover only some of the features and capabilities of *COLUMN*. However, these examples are sufficient to indicate that *COLUMN* is capable of producing designs that are comparable and, in certain instances, more economical than those suggested in the textbooks.

## 6. SUMMARY AND CONCLUSIONS

### 6.1 Summary

This research was undertaken for a twofold purpose, namely;

1. to study the issues that need to be addressed in developing programs that automate the structural engineering design process, and
2. to investigate how these issues are considered in the development of systems for the design and analysis of reinforced concrete members.

The techniques and tools used in building knowledge-based expert systems were discussed and their particular application to the design of reinforced concrete structures was emphasized.

A knowledge-based system for the analysis and proportioning of reinforced concrete columns has been developed and presented. The reasoning strategy simulated by the system follows that used by an expert system in designing reinforced concrete columns, namely:

1. Select a potential design
2. Evaluate the design
3. Modify the design

The knowledge required for proportioning column sections is structured using a production rule based approach. A forward chaining scheme is used to invoke the rules that apply for the particular loading conditions.

## 6.2 Conclusions

This research has demonstrated that knowledge-based expert systems for the proportioning and detailing structural elements can be written. Such systems should be capable of producing designs that are:

1. Safe and serviceable
2. Constructible
3. Economical
4. In accordance with prescribed limitations imposed by the designer.

*COLUMN* fulfills these requirements and, although still in its development stage, the column sections produced by the system have shown to be comparable with those designed in actual practice by experienced structural engineers.

## REFERENCES

- ACI Committee 318. "Building Code Requirements for Reinforced Concrete (318-83)". American Concrete Institute, Detroit, 1983.
- ACI Committee 318. "Commentary on Building Code Requirements for Reinforced Concrete (318-83)". American Concrete Institute, Detroit, 1983.
- ACI Committee 340. "Design Handbook In Accordance With the Strength Design Method of ACI 318-83: Volume 2 - Columns". ACI Special Publication, SP-17A(85), American Concrete Institute, Detroit, 1985.
- Adeli, H. "Knowledge-based Expert Systems in Structural Engineering". Proceedings of the Second International Conference on Civil Engineering Computing, Vol. 2, London, Dec 3-5, 1985, pp. 391-398.
- Adeli, H. and Paek, Y.J "Computer-Aided Design of Structures Using LISP". Computers and Structures, Vol.22, No.6, London, 1986, pp. 939-956.
- Allwood, R.J. et al. "Some Experiences from Evaluating Expert System Shell Programs and Some Potential Applications". Proceedings of the Second International Conference on Civil and Structural Engineering Computing, Vol.2, London, Dec 3-5, 1985, pp. 415-420.
- Augusti, G. and Borri, A. "The Use of Microcomputers in Structural Design: Some Considerations and an Example". Proceedings of the International Conference on Computer Aided Analysis and Design of Concrete Structures, Part II, Split, Yugoslavia, Sept. 17-21, 1984, pp. 963-976.
- Balaguru, P. "Analysis and Design of Reinforced and Prestressed Concrete Compression Members Using Desk Top Computers". Computer Applications in Concrete Technology, SP-98, American Concrete Institute, Detroit, 1987, pp. 249-280.
- Borse, G.J. Fortran 77 and Numerical Methods for Engineers, PWS Publishers, Boston, 1985.
- Breysse, D. "Automatic Design of Structures". Proceedings of the International Conference on Computer Aided Analysis and Design of Concrete Structures, Part II, Split, Yugoslavia, Sept. 17-21, 1984, pp. 791-802.

- British Standards Institution. **The Structural Use of Concrete**, BS 8110, Part 2, London, 1985.
- Canadian Portland Cement Association. **ADOSS - Analysis and Design of Slab Systems**, User's Manual, Ottawa, 1985.
- Canadian Portland Cement Association. **Concrete Design Handbook**, CPCA, Ottawa, 1985.
- Canadian Standards Association. "Design of Concrete Structures for Buildings". CAN3-A23.3-M77, 1977.
- Canadian Standards Association. "Design of Concrete Structures for Buildings". CAN3-A23.3-M84, 1984.
- Clarke, D. **Computer Aided Structural Design**, John Wiley and Sons Ltd., Chichester, 1978.
- Clifton, J.R. and Oltikar, B.C. "Expert System for Selecting Concrete Constituents". **Computer Applications in Concrete Technology**, SP-98, American Concrete Institute, Detroit, 1987, pp. 1-24.
- Croft, D.D. "The GLADYS Computer System". **Proceedings of the CSCE Specialty Conference on Computers in Structural Engineering Practise**, Montreal, Oct. 6-7, 1977, pp. 133-156.
- Davister, M.D. "A Computer Program for Exact Analysis". **Concrete International Design and Construction**, July 1986, Vol.8, No.7, pp. 56-63.
- Ehsani, M.R. "CAD for Columns". **Concrete International Design and Construction**, September, 1986, Vol.8, No.9, pp. 43-47.
- Elio, R. "Questions of Knowledge Investigations in the Field of Artificial Intelligence". **New Trail**, Edmonton, 1986.
- Etter, D.M. **Structured Fortran 77 for Engineers and Scientists**, The Benjamin/Cummings Publishing Company Inc., California, 1983.
- Feigenbaum, E. "Expert Systems in the 1980's, in **Machine Intelligence**". ed. A. Bond, Pergamon Press, 1981.
- Fenves, S.J. "What is an Expert System". **Expert Systems in Civil Engineering**, proceedings of a Symposium sponsored by the Technical Council on Computer Practices of the American Society of Civil Engineers, Seattle, Washington, Apr. 8-9, 1986, pp. 1-6.
- Ferguson, P.M. **Reinforced Concrete Fundamentals SI Version**, John Wiley & Sons, Inc., New York, 1981.

- Finn, G.A. and Reinschmidt, K.F. "Expert Systems in an Engineering Construction Firm". **Expert Systems in Civil Engineering, Proceedings of a Symposium sponsored by the Technical Council on Computer Practises of the American Society of Civil Engineering, Seattle, Washington, Apr. 8-9, 1986, pp. 40-54.**
- Frost, R.A. **Introduction to Knowledge Base Systems.** William Collins Sons & Co. Ltd., London, 1986.
- Gattas, M. et al. "Interactive Graphics Dynamic Analysis of Frames". **ASCE Specialty Conference on Dynamic Response of Structures, Atlanta, Georgia, January 15-16, 1981.**
- Halvorsen, G.T. "Reinforced Concrete Column Design Program". **Design of Structural Concrete, COM-1(83), American Concrete Institute, Detroit, 1983, pp. 139-148.**
- Hapgood, W. **1st Class, Instruction Manual, Programs in Motion Inc., Massachusetts, 1986.**
- Hayes-Roth, F., Waterman, D., and Lenat, D. **Building Expert Systems, Addison-Wesley Reading, Massachusetts, 1983.**
- Hoit, M.I., Fagundo, F.E. and Johnson, H. "Integrated Design Environment For Concrete Structures". **Computer Applications in Concrete Technology, SP-98, American Concrete Institute, Detroit, 1987, pp. 139-148.**
- Kostem, C.N. "Attributes and Characteristics of Expert Systems". **Expert Systems in Civil Engineering, Proceedings of a Symposium sponsored by the Technical Council on Computer Practices of the American Society of Civil Engineers, Seattle, Washington, Apr. 8-9, 1986, pp. 30-39.**
- Lenat, D.B., Hayes-Roth, F. and Klahr, D. "Cognitive Economy". **Rept. HPP-79-15, Heuristic Programming Project, Computer Science Department, Stanford University, California, 1979.**
- Leung, C-K. and Simmonds, S.H. "Reinforced Concrete Column Design Program". **Structural Engineering Report No.116, University of Alberta, Edmonton, April, 1984.**
- Ludvigsen, P.J. et al. "Expert System Tools for Civil Engineering Applications". **Expert Systems in Civil Engineering, Proceedings of a Symposium sponsored by the Technical Council on Computer Practices of the American Society of Civil Engineers, Seattle, Washington, Apr. 8-9, 1986, pp. 18-29.**



- MacGregor, J.G. "Simple Design Procedures for Concrete Columns". Introductory Report for the Symposium on the Design and Safety of Reinforced Concrete Compression Members, Volume 15, Quebec, 1974.
- MacGregor, J.G., Breen, J.E. and Pfrang, E.O. "Design of Slender Concrete Columns". American Concrete Institute Journal, Vol.67, No.1, January, 1970, pp. 6-28.
- MacGregor, J.G. and Hage, S.E. "Stability Analysis and Design of Concrete Frames". Journal of the Structural Division, American Society of Civil Engineers, October, 1977, Vol.103, No.ST10, pp. 1953-1970.
- Maher, M.L. "Problem Solving using Expert System Techniques". Expert Systems in Civil Engineering, Proceedings of a Symposium sponsored by the Technical Council on Computer Practices of the American Society of Civil Engineers, Seattle, Washington, Apr. 8-9, 1986, pp. 7-17.
- Maher, M.L. and Fenves, S.J. "HI-RISE: An Expert System for the Preliminary Structural Design of High Rise Buildings". Proceedings of the IFIPWG 5.2 Work Conference on Knowledge Engineering in Computer Aided Design, Budapest, Hungary, Sept. 17-19, 1984, pp. 125-140.
- Microsoft Corporation. Microsoft FORTRAN 4.0 Optimizing Compiler User's Guide and Language Manual, 1987.
- Park, R. and Paulay, T. Reinforced Concrete Structures, John Wiley and Sons, Inc., Toronto, 1975.
- Pillai, S.U. and Kirk, D.W. Reinforced Concrete Design in Canada, McGraw-Hill Ryerson Ltd., Toronto, 1983.
- Pollalis, S.N. "Decision Support Systems for the Design of Reinforced Concrete Structures". Computer Applications in Concrete Technology, SP-98, American Concrete Institute, Detroit, 1987, pp. 183-195.
- Raic, G. "Interactive Approach to Database in Structural Analysis". Proceedings of the International Conference on Computer Aided Analysis and Design of Concrete Structures, Part II, Split, Yugoslavia, Sept. 17-21, 1984, pp. 987-996.
- Rehak, D.R., Howard, H.C., and Sriram, D. "Architecture of an Integrated Knowledge Based Environment for Structural Engineering Applications". Proceedings of the IFIP WG 5.2 Work Conference on Knowledge Engineering in CAD, Budapest, Hungary, Sept. 17-19, 1984, pp. 89-124.

- Rice, P.F. et al. **Structural Design Guide to the ACI Building Code**, Van Nostrand Reinhold Company Inc., New York, 1985.
- Ross, D.A. and Yen, J.R. "Interactive Design of Reinforced Concrete Columns with Biaxial Bending". **ACI Journal**, Proceedings V.83, No.6, Nov.- Dec. 1986, pp. 988-993.
- Saouma, V.E. et al. "Interactive Computer Graphics in the Design of Reinforced Concrete Buildings". **Proceedings of the International Conference on Computer Aided Analysis and Design of Concrete Structures, Part II, Split, Yugoslavia, Sept. 17-21, 1984**, pp. 937-950.
- Stevens, L. **Artificial Intelligence**. Hayden Publishing Company, Inc., New Jersey, 1985.
- Szalwinski, C.M., Johnston, J.Z. and Blackwell, W. "CONCBM-A Design Program for Reinforced Concrete Beams". **Proceedings of the CSCE Specialty Conference on Computers in Structural Engineering Practise, Montreal, Oct. 6-7, 1977**, pp. 239-274.
- Thadani, B.N. **Practical Reinforced Concrete Design with Computer Use**, Cantext Publications, Winnipeg, 1986.
- Wager, D.M. "Can Expert Systems Help the Construction Industry?". **Proceedings of the Second International Conference on Civil and Structural Engineering Computing, Vol.2, London, Dec. 3-5, 1985**, pp. 387-390.
- Wang, C. and Salmon, C.G. **Reinforced Concrete Design**. Harper and Row, Publishers, Inc., New York, 1979.
- Wijesundera, D.A. and Harris, F.C. "The Integration of an Expert System into the Construction Planning Process". **Proceedings of the Second International Conference on Civil and Structural Engineering Computing, Vol.2, London, Dec. 3-5, 1985**, pp. 399-398.
- Wright, E.W. "Application Software for Building Structures Where will it come from?". **Proceedings of the CSCE Specialty Conference on Computers in Structural Engineering Practise, Montreal, Oct. 6-7, 1977**, pp. 7-34.
- Bechara, R.M. "A Knowledge Based System for the Design of Reinforced Concrete Columns". **M.Sc. Thesis, Civil Engineering Department, University of Pittsburgh, 1985**.

## APPENDIX A - DETAILED CALCULATIONS

### A.1 Sign Convention and Nomenclature

The sign convention of the moments entered by the user is as shown in Fig. A.1. Positive moments at either top or bottom of the column are moments which act in a clockwise direction and vice versa. Therefore, when entered end moments are both of the same sign, the column deflects in double curvature; otherwise, the column deflects in single curvature. In accordance with the codes, the program *COLUMN* determines which of the end moments is larger and sets the value of this moment to be positive. The smaller end moment is set to a positive value if the column is bent in single curvature and negative if bent in double curvature.

The nomenclature used in describing the column cross section is as indicated in Fig. A.2. When bars are placed on all faces, the number of bars on each x-face  $N_x$  includes the two bars at the corners as illustrated in Fig. A.2. The direction of the dimensions which is parallel to either of the principal axes is indicated by the subscript.

### A.2 Slenderness Effects in Braced Members

For members braced against sidesway, when the slenderness ratio  $kl_u/r$  is less than  $(34 - 12M_1/M_2)$ , the member is considered to be short and thus slenderness effects are neglected.  $k$  is the effective length factor,  $l_u$  is the unsupported length of column, and  $r$  is the radius of

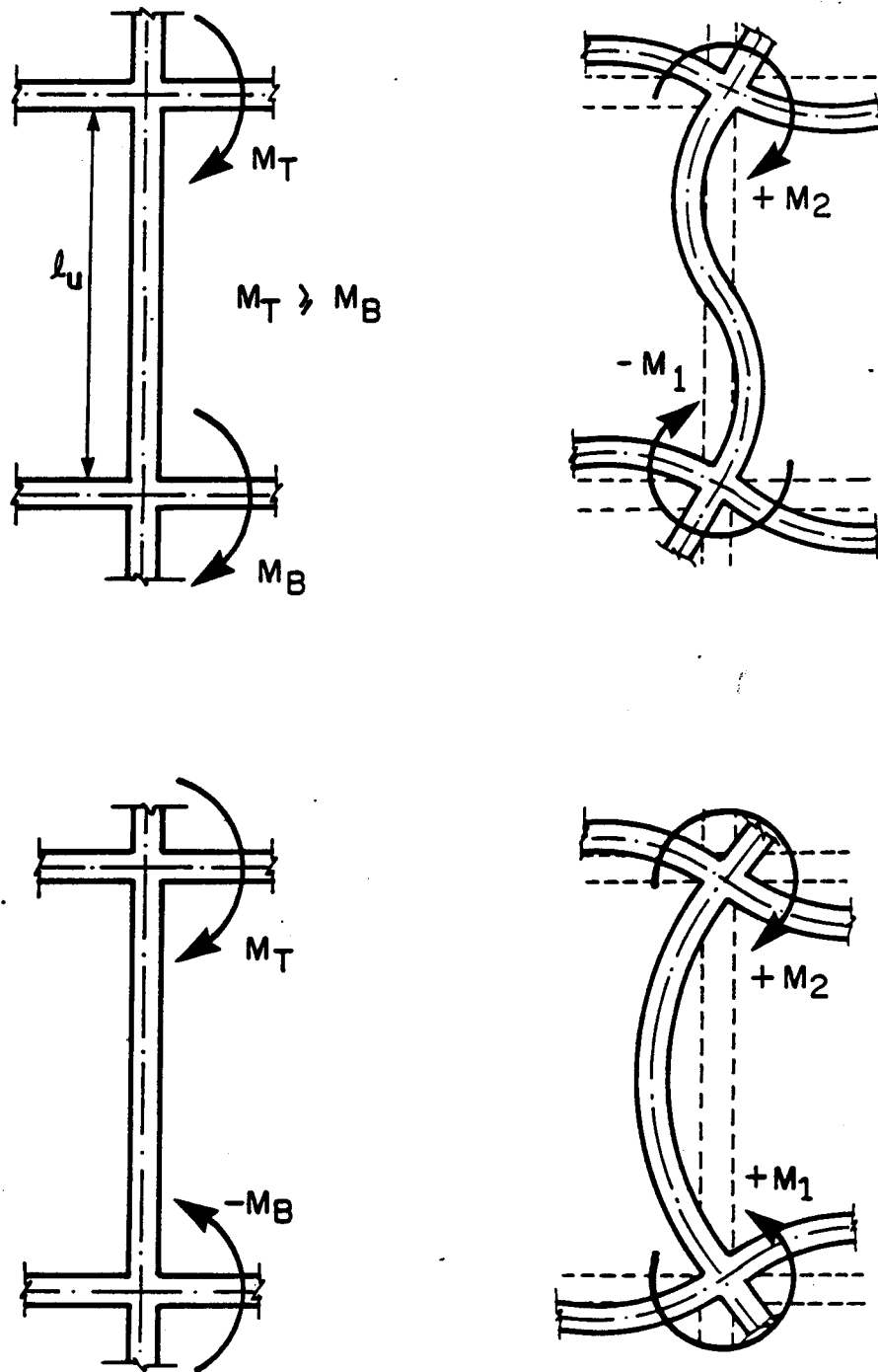

(a) Input Moments from Analysis Clockwise Positive (b) Deflected Shape and Design Moments used by Program

Figure A.1 Moment Sign Convention

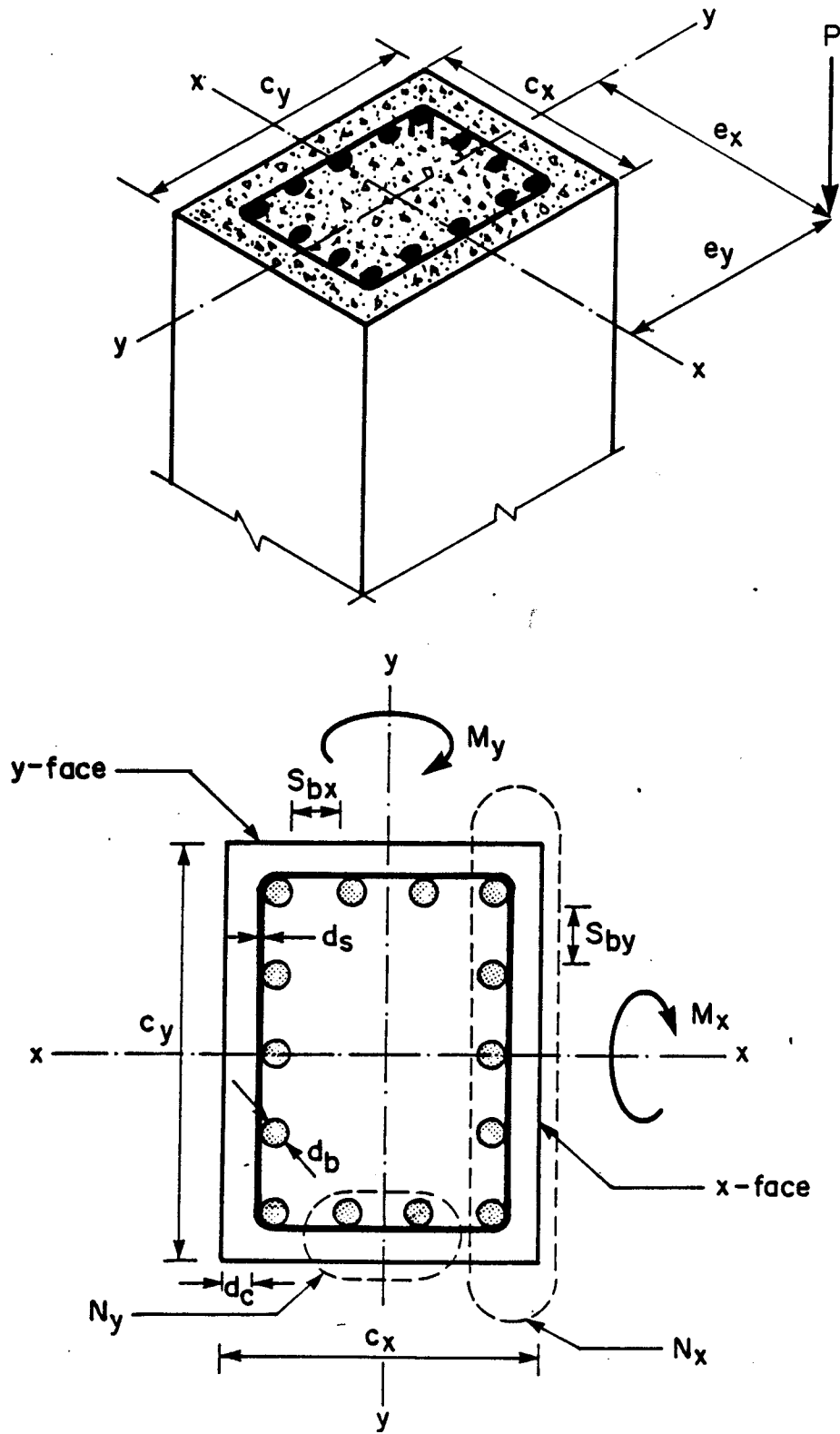

Figure A.2 Sign Convention and Nomenclature

gyration of the cross section of the column about the axis under consideration. Values of  $k$  and  $l_u$  are entered by the user and the value of  $r$  is computed by:

$$r = \sqrt{\frac{I_g}{A_g}} \quad [A.1]$$

where  $I_g$  is the moment of inertia of the gross section about centroidal axis under consideration, neglecting reinforcement.

The larger factored end moment,  $M_2$  is always positive and its value should not be less than the axial load acting at a minimum eccentricity equal to:

1. The greater of (0.1h) mm and 25 mm for tied columns and the greater of (0.05h) mm and 25 mm for spiral columns in accordance with Section 8.4.6 CAN3-A23.3-M77.
2. (15 + 0.03h) mm as stipulated in Section 10.11.6.4 CAN3-A23.3-M84.
3. (0.60 + 0.03h) in. in accordance with ACI 318-83 Section 10.11.5.4 for a braced frame or Section 10.11.5.5 in the case of an unbraced frame.

Therefore, if the eccentricity computed from the entered moments and loads is less than the minimum stipulated by the codes, the design moment is based on the value of the code minimum eccentricity. If  $kl_u/r$  is less than  $(34 - 12M_1/M_2)$ , the minimum eccentricity does not apply and the equation for the maximum axial load governs.

In the case where the column is axially loaded and hence there are essentially no moments acting at either end of the column, the codes recommend values of  $M_1/M_2$  for the purposes of calculating  $C_m$ , the equivalent moment factor. However, for the same loading situation, the codes do not give any indication as to what value of  $M_1/M_2$  to use for checking whether slenderness effects are to be accounted for or not. In this case there are two possible approaches of selecting a value of  $M_1/M_2$  for consideration of slenderness effects.

The first is to assume conservatively that the column bends in symmetrical single curvature, thus the value  $M_1/M_2$  is taken to be equal to 1.0. Design examples in textbooks by Wang and Salmon (1985), and by Pillai and Kirk (1983) use this value. However, the more rational approach seems to be that, although a minimum moment as required by the codes is applied, the value of the moment at the other end of the member as computed from a frame analysis is zero. Consequently, the value of  $M_1/M_2$  is zero and the value of  $(34 - 12M_1/M_2)$  is equal to 34. Therefore, the uniaxially loaded member is treated similarly to the case where a member is subjected to a uniaxial bending moment at one end only. This approach is considered to be more appropriate since it prevents the use of spurious moments.

### A.3 Moment Magnifier for Slender Braced Columns

Slenderness effects in long braced columns are accounted for by increasing the applied larger end moment by a magnification factor  $\delta_b$ . The design moment is thus given by:

$$M_c = \delta_b M_2 \quad [A.2]$$

Where  $M_c$  is the magnified factored design moment and  $\delta_b$  the magnification factor computed from entered loading and geometry:

$$\delta_b = \frac{C_m}{1 - \frac{P_f}{\phi P_c}} \geq 1.0 \quad [A.3]$$

where  $P_c$  is the critical load of the member described by:

$$P_c = \frac{\pi^2 EI}{(kl_u)^2} \quad [A.4]$$

and  $C_m$  is the equivalent moment factor given by:

$$C_m = 0.6 + 0.4 \frac{M_1}{M_2} \geq 0.4 \quad [A.5]$$

The ratio of the column end moments  $M_1/M_2$  is taken as 1 if both moments  $M_1$  and  $M_2$  acting on the compression member are zero.



When CAN3-A23.3-M77 and ACI 318-83 are used, the value of  $\phi$  is the strength reduction factor, whilst for CAN3-A23.3-M84  $\phi$  is replaced by  $\phi_m$ , the member resistance factor.

The flexural stiffness, EI, used in calculating the value of  $P_c$  is computed using the more "accurate" of the two equations stipulated in the codes (MacGregor et al., 1970).

$$EI = \frac{0.2E_c I_g + E_s I_{se}}{1 + \beta_d} \quad [A.6]$$

In the equation for EI, the influence of the longitudinal reinforcement is considered by including the flexural stiffness of the steel,  $E_s I_{se}$ , where  $E_s$  is the modulus of elasticity of the steel and  $I_{se}$  the moment of inertia of the steel reinforcement about the centroidal axis under consideration. This is computed as described in Section A.7. The use of Equation [A.6] for evaluating EI is possible since the required information on the content of reinforcement is already available at this stage of the design process.

The factor  $\beta_d$ , which is the absolute value of the ratio of the maximum factored dead load moment to the maximum factored total load moment  $M_2$ , is used to approximately account for the reduction of the value of EI because of creep due to sustained loads.

If the value of  $P_f$ , the factored axial load, is larger than the value of  $P_c$  multiplied by  $\phi$ , then the column is

unstable and therefore a larger column cross section is necessary. If the program is in check mode, a message indicating that the column is unstable is printed, otherwise the column section is incremented and the process of selecting reinforcement and checking of slenderness effects is repeated. Incrementing the reinforcement content is not practical as this does not affect significantly the value of the flexural stiffness  $EI$  of the member. If the value of the moment magnifier  $\delta_b$  is less than 1, it is set to 1.

#### A.4 Slenderness Effects in Unbraced Columns

For frames that are not braced against sidesway, the column is considered to be long if the value of slenderness ratio  $kl_u/r$  is greater than 22, when design is carried out using CAN3-A23.3-M77 and ACI 318-83. This provision is not stipulated in CAN3-A23.3-M84 and therefore in an unbraced frame all the columns are considered to be slender.

The magnified moment is computed differently in all three codes considered. In CAN3-A23.3-M77 the magnified moment  $M_c$  is defined by:

$$M_c = \delta M_2 \quad [A.7]$$

where as in the braced case,  $M_2$  is the larger factored end moment and  $\delta$  is the moment magnifier for the sway case computed as described in Section A.5.

In CAN3-A23.3-M84 the magnified moment  $M_c$  is defined by:

$$M_c = \delta_b M_2 \quad [A.8]$$

where  $\delta_b$  is the magnification factor for the braced case as determined in Section A.3 and  $M_2$  is the greater of the  $(M_{ns} + \delta_s M_s)$  computed for both ends of the column. The magnifier  $\delta_s$  takes into account lateral drift effects computed as described in Section A.5,  $M_{ns}$  are the moments due to gravity loads and  $M_s$  are the moments associated with sway.

In ACI 318-83 the magnified factored moment  $M_c$  is defined by:

$$M_c = \delta_b M_{2b} + \delta_s M_{2s} \quad [A.9]$$

where  $\delta_b$  and  $\delta_s$  are identical to those used in CAN3-A23.3-M84 and  $M_{2b}$  and  $M_{2s}$  are similar to  $M_{ns}$  and  $M_s$  used in CAN3-A23.3-M84 respectively.

For CAN3-A23.3-M84 and ACI 318-83, it is evident from the above that, for the purposes of computing the magnified moment for members that are not braced against sidesway, it is not enough to distinguish between those moments that result from dead loads, live loads and wind loads. A further breakdown that distinguishes moments due to gravity loads, from moments that result from lateral drift effects is

necessary. Consequently, at the analysis stage, it is important to differentiate between those loads that induce an appreciable sway deflection (the codes consider a lateral deflection to be appreciable when it is greater than  $l_u/1500$ ) from the gravity loads. Moments  $M_s$  and  $M_{ns}$  corresponding to these two loading conditions respectively, should therefore be computed from a separate structural analysis of the frame. Consequently, for an unbraced frame in the case of CAN3-A23.3-M84 or when the column is classified as slender in accordance with CAN3-A23.3-M77 and ACI 318-83, the program prints a message indicating that additional information is required to compute the magnified moment. At this stage, for the program to determine the largest possible magnified moment, the values of  $M_s$  and  $M_{ns}$  at both ends of the member need to be entered.

If the unbraced compression member is axially loaded and therefore there is no moment at either end of the member, a minimum moment computed identically to that used for the braced condition, using a minimum eccentricity and the factored design load, is considered in the case of CAN3-A23.3-M77. When ACI 318-83 is used, a minimum moment associated with sway  $M_{2s}$  is computed using a factored gravity axial load acting at an eccentricity of  $(0.6 + 0.03h)$  in. In the case of CAN3-A23.3-M84 the use of minimum eccentricity is not specified.

### A.5 Moment Magnifier for Slender Unbraced Columns

The moment magnifier associated with sway denoted by  $\delta$  in CAN3-A23.3-M77 and  $\delta_s$  in CAN3-A23.3-M84 and ACI 318-83 is defined by:

$$\delta_s = \frac{1}{1 - \frac{\sum P_f}{\phi \sum P_c}} \geq 1.0 \quad [\text{A.10}]$$

where  $\sum P_f$  is the sum of the factored axial loads,  $\sum P_c$  is the sum of critical loads of all the columns in the storey, and the value of  $\phi$  is identical to the  $\phi$  used in determining the value of  $\delta_b$ . The value of  $\delta_s$  is common to all the columns in the storey.

The value of  $P_c$  for the individual columns depends on the geometrical properties of the particular cross section of the member. Since this information is not known *a priori*, the normal approach in design practice is to assume a value of  $\delta_s$  and following the determination of trial designs of all compression members in the storey the value of  $\delta_s$  is verified. This value is adjusted accordingly and the whole process is repeated until the computed value of  $\delta_s$  converges to the assumed value.

Whilst this approach is appropriate and can be implemented in a CAD environment for frames, it is not applicable to CAD programs for the design of isolated columns since additional information on the design of the remaining columns in the storey is required.

For the case of a slender unbraced column, in addition to the information regarding moments, the program requests the value of  $\Sigma P_c$  and the number of columns in the storey. The value of  $\Sigma P_c$  is then computed by:

$$\Sigma P_c = N_{col} \times P_c \quad [A.11]$$

where  $P_c$  is the critical load of the column under consideration based on the current dimensions and  $N_{col}$  is the number of columns in the storey. This implies that all the columns in the storey are assumed to be identical. Since the philosophy adopted in determining a column section is based on only incrementing the dimensions, the value of  $\Sigma P_c$  can be considered to be the possible minimum consistent with the condition that all columns in the storey have similar shape,  $k$  values, and dimensions. If this is not the case, then, when the column has been incremented considerably there is the possibility that any of the other columns in the storey have smaller dimensions than the one being considered. Notwithstanding this shortfall, in the absence of data on the remaining part of the structure, such an approach seems to be the more appropriate for computing a feasible value for  $\delta_s$ . It should be noted that, the value of  $P_c$  and therefore  $\delta_s$  is only slightly affected by the individual column size. However, when the storey has a considerable number of columns, the cumulative effect of the column sizes in determining  $\Sigma P_c$  and therefore  $\delta_s$  could be significant

(Ferguson, 1981).

If the value of  $\delta_s$  is larger than 2, the column section is incremented and the process of selecting the reinforcement content and checking slenderness effects is repeated. Although the latter condition of a maximum limit of 2 on the value of  $\delta_s$  is not specified in the codes, in design practice it is advisable to use this limit in order to account for serviceability requirements and to avoid any possible instability of the unbraced frame (Commentary to CAN3-A23.3-M84). The column cross sectional dimensions are also incremented if the value of  $\Sigma P_c$  is greater than the value of the term  $\phi \Sigma P_c$ .

When CAN3-A23.3-M77 is used, the value of  $\delta_s$  obtained for the entire storey using Equation [A.10] is checked with the value of  $\delta_b$  computed for the individual column using Equation [A.3] for the braced column case, and the larger of the two values is the value used as  $\delta$  in Equation [A.7].

#### **A.6 Moment Magnification for Different Loading Conditions**

For members subjected to biaxial bending, the moment about each principal axis is magnified using  $\delta$ 's computed from the corresponding conditions of restraint about each axis separately. When members are subjected to uniaxial bending, the moment is magnified using  $\delta$  computed about the axis under consideration.

If the member is axially loaded with no moments at either end, the slenderness ratio  $kl_u/r$  is computed about

each principal axis. The magnified moment is computed using the specified minimum moment and  $\delta$  calculated about the principal axis that produces the largest slenderness ratio.

The slenderness factors and the magnified moments about the x and y principal axes are computed in subroutines *SLENDX* and *SLENDY* respectively.

#### A.7 Evaluation of Moment of Inertia of Steel Reinforcement

The moment of inertia of steel reinforcement  $I_{se}$  about each principal axis of the member cross section used in computing the flexural stiffness  $EI$  in Equation [A.6] is computed for the various possible reinforcement patterns using the general formula from direct application of statics defined by:

$$I_{se} = \sum_{i=1}^n A_{bi} x_{bi}^2 \quad [A.12]$$

where  $A_{bi}$  is the area of the individual bar whose centroid is situated a distance  $x_{bi}$  from the centroidal axis of the section, and  $n$  is the total number of bars in the section.  $I_{sex}$  and  $I_{sey}$ , the moment of inertia of steel reinforcement about the x and y axis respectively are computed by the subroutine *ISTEEL*, using the following expressions.

##### A.7.1 Bars in a Rectangular Array

For bars on only the x-faces:



$$I_{sey} = 0.25A_{st}(\gamma_x c_x)^2 \quad [A.13]$$

where  $\gamma_x$  is the ratio of the centre to centre distance between the outermost reinforcing bars (measured perpendicular to the axis of bending) to the overall depth of the column  $c_x$  defined by:

$$\gamma_x = \frac{c_x - 2d_c - 2d_s - d_b}{c_x} \quad [A.14]$$

where  $d_c$  is the clear thickness of concrete cover,  $d_b$  is the nominal diameter of the longitudinal bars and  $d_s$  is the diameter of the lateral reinforcement.

The moment of inertia about x-axis is defined by:

$$I_{sex} = \frac{4A_{st} \sum y(i)^2}{N_b} \quad [A.15]$$

where  $A_{st}$  is the total area of the longitudinal reinforcement,  $N_b$  the total number of bars, and  $y(i)$  is the distance from the centroid of the (i)th bar to the x-axis defined by:

$$y(i) = 0.5\gamma_y c_y - (i-1)(d_b + S_{by}) \quad [A.16]$$

where

$$i = 1, K$$

$$K = (N_b - 1.0)/4.0 + 0.51$$

and  $K$  is truncated to an integer to account for the

situation when reinforcing bars are placed on the centroidal axis, in which case these bars do not contribute to the total value of the moment of inertia of reinforcement.  $\gamma_y$  is similar to  $\gamma_x$  except it is measured perpendicular to the x-axis and is defined by:

$$\gamma_y = \frac{c_y - 2d_c - 2d_s - d_b}{c_y} \quad [\text{A.17}]$$

and  $S_{by}$  is the clear bar spacing between bars in the x-faces.

For bars only on the y-faces:

$$I_{sey} = \frac{4A_{st} \sum x(i)^2}{N_b} \quad [\text{A.18}]$$

where  $x(i)$  is the distance from the centroid of the (i)th bar to the y-axis defined by:

$$x(i) = 0.5\gamma_x c_x - (i-1)(d_b + S_{bx}) \quad [\text{A.19}]$$

where

$$i = 1, K$$

$$K = (N_b - 1.0)/4.0 + 0.51$$

where again  $K$  is truncated to an integer.

The moment of inertia of the reinforcement about x-axis is given by:

$$I_{sex} = 0.25A_{st}(\gamma_y c_y)^2 \quad [\text{A.20}]$$

Both  $\gamma_x$  and  $\gamma_y$  are computed using Equation [A.14] and [A.17] respectively.

For bars on all faces:

$$I_{sey} = 0.25A_{sx}(\gamma_x c_x)^2 \quad [A.21]$$

for the case when there are no bars on the y-faces. This situation occurs when there are only four bars in the column section in which case, the corner bars are considered as bars on the x-face. Otherwise, the moment of inertia  $I_{sey}$  is given by:

$$I_{sey} = 0.25A_{sx}(\gamma_x c_x)^2 + (2A_{sy}/N_{by}) \sum_{i=1}^k x(i)^2 \quad [A.22]$$

where

$$x(i) = 0.5\gamma_x c_x - d_b - S_{by} - (i-1)(S_{by} + d_b) \quad [A.23]$$

where

$$i = 1, K$$

$$K = (2.0N_{by} - 1.0)/4.0 + 0.51$$

and as in previous cases  $K$  is truncated to an integer.  $A_{sy}$  and  $A_{sx}$  are the total area of steel on the y and x faces respectively,  $N_{by}$  is the number of bars in a single y-face and all other variables are similar to those described in the above sections (Fig. A.3).

Similarly the moment of inertia of steel about the x-axis is defined by:

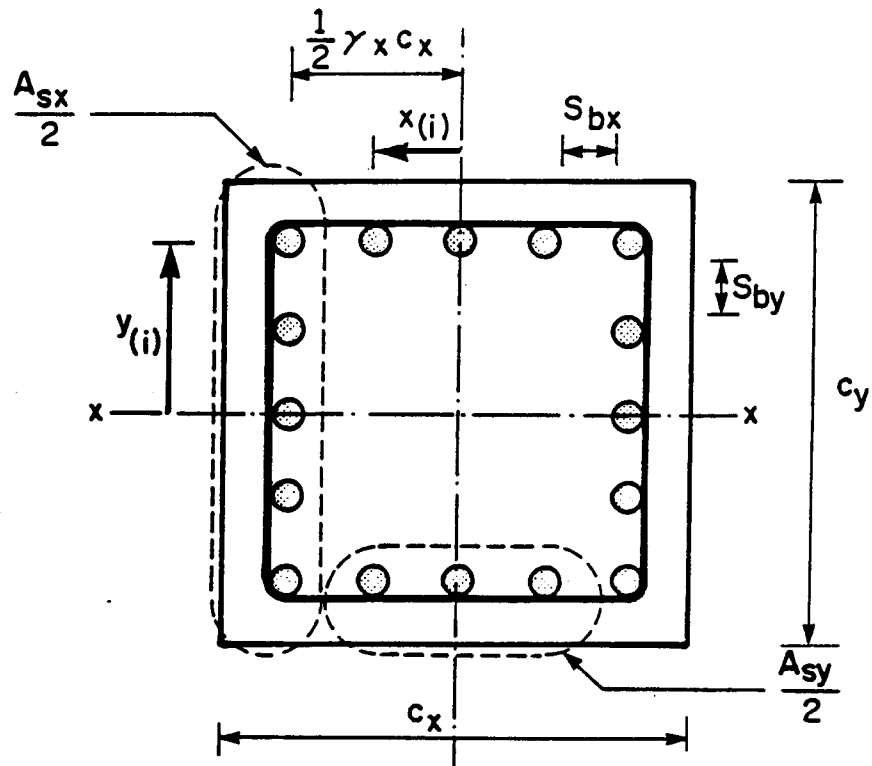

Figure A.3 Reinforcement in a Rectangular Array

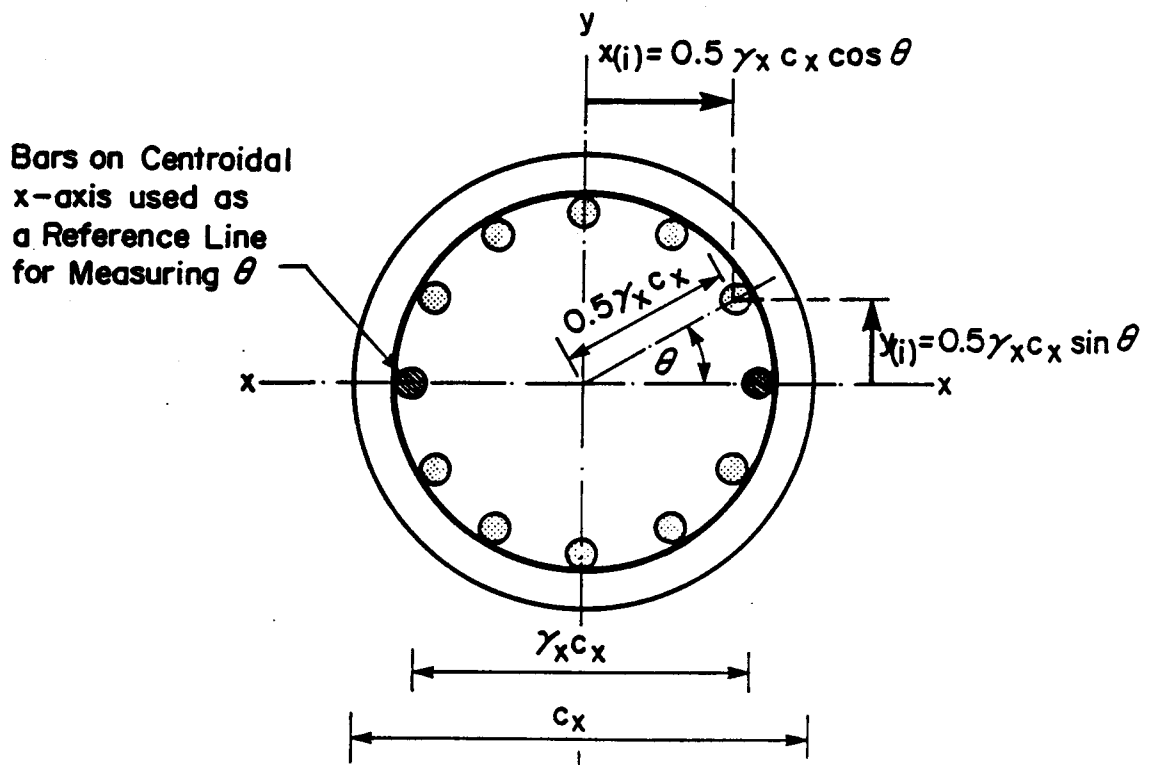

Figure A.4 Reinforcement in a Circular Array

$$I_{sex} = 0.25A_{sy}(\gamma_y c_y)^2 + (2A_{sx}/N_{bx}) \sum_{i=1}^k y(i)^2 \quad [A.24]$$

where

$$y(i) = 0.5\gamma_y c_y - (i-1)(S_{bx} + d_b) \quad [A.25]$$

where

$$i = 1, K$$

$$K = (2.0N_{bx} - 1.0)/4.0 + 0.51$$

where the definition of the variables is as described above.

### A.7.2 Bars in a Circular Array

In order to compute the moment of inertia of reinforcement in a circular pattern, a reference line including two bars is made to coincide with the centroidal x-axis (Fig. A.4) The angles ( $i\theta$ ) subtended by the lines drawn from the centre of the section to the centroid of the bars and this reference axis are computed in order to calculate the distances of the bars from the axes denoted by  $x(i)$  and  $y(i)$ .

The moment of inertia of reinforcement about the y-axis is given by:

$$I_{sey} = \frac{A_{st} [0.5(\gamma_x c_x)^2 + 4 \sum_{i=1}^K x(i)^2]}{N_b} \quad [A.26]$$

where

$$x(i) = 0.5\gamma_x c_x \cos(i\theta) \quad [A.27]$$

where

$$i = 1, K$$

$$K = (N_b - 3.0)/4.0 + 0.51$$

where  $K$  is truncated to an integer.

The moment of inertia of the reinforcement about the  $x$ -axis is defined by:

$$I_{sex} = \frac{A_{st}[0.5\gamma_x c_x + 4\sum_{i=1}^K y(i)^2]}{N_b} \quad [A.28]$$

where

$$y(i) = 0.5\gamma_x c_x \sin(i\theta) \quad [A.29]$$

where

$$i = 1, K$$

$$K = (N_b - 4.0)/4.0 + 0.51$$

and  $M$  is an integer variable that is defaulted to 1 when bars are located on the centroidal  $y$ -axis of the member cross section, otherwise  $M$  defaults to 0.

#### A.8 Modification of Capacity Reduction Factor

In the case of CAN3-A23.3-M77 and ACI 318-83 the capacity reduction factor  $\phi$  is modified by comparing the value of the axial load capacity computed for the particular trial location of the neutral axis  $P_n$ , and  $P'$  which is the smaller of  $0.1(f'_c)A_g$  or  $P_b$  the axial load strength at balanced strain conditions. When  $f_y$  does not exceed 60,000 psi or 400 MPa and the value of  $\gamma$  computed using Equation [A.14] or [A.17] is not less than 0.70, then  $P'$  is taken as  $0.1(f'_c)A_g$ . The modified value of the reduction factor when  $P_n$  is less  $P'$  is given by (Fig. A.5):

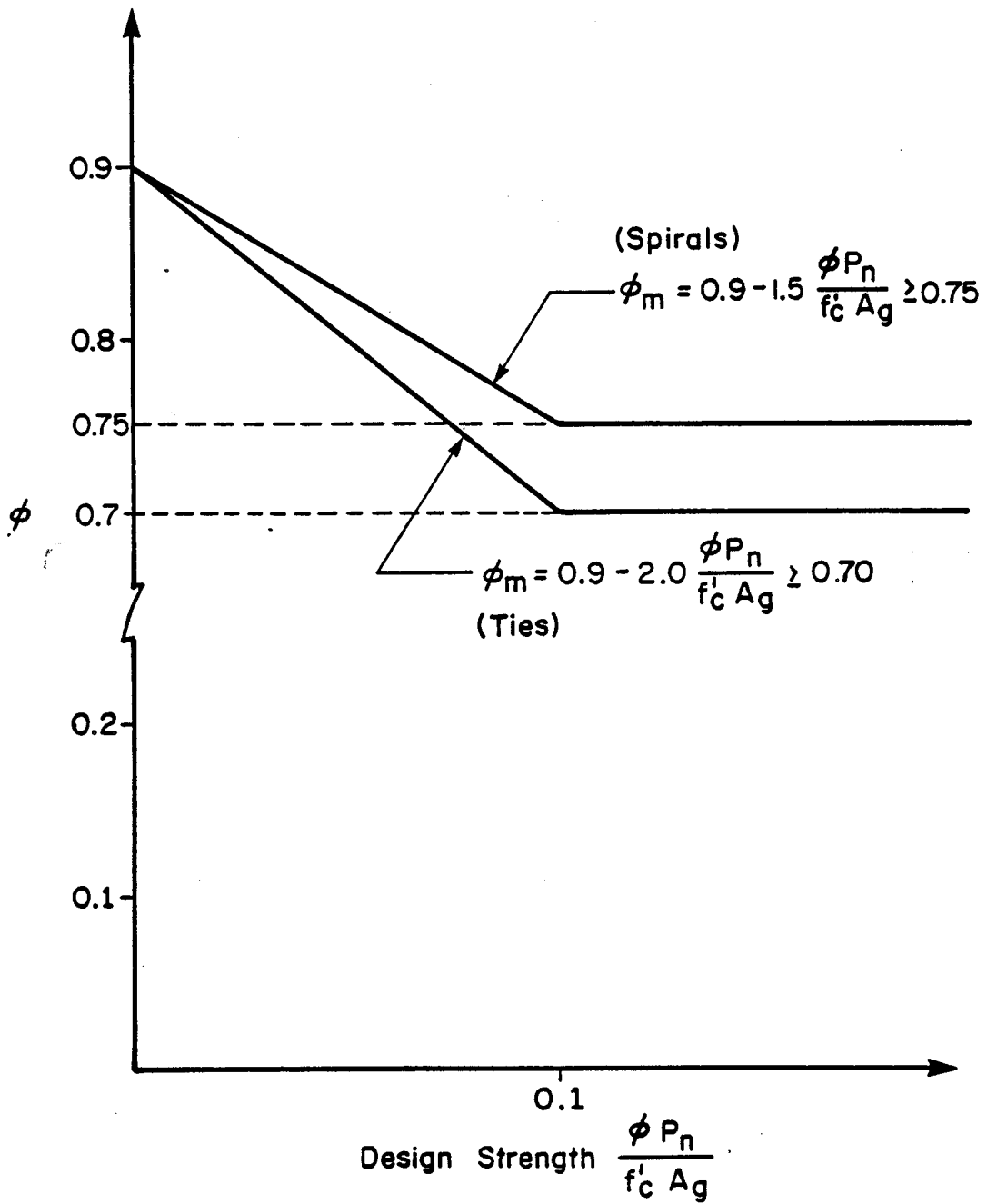

$\gamma = 0.7$

$f_y \leq 60,000 \text{ psi or } 400 \text{ Mpa}$

Figure A.5 Variation of  $\phi$

$$\phi_m = 0.9 - \frac{(0.9 - \phi)\phi P_n}{P'} \quad [A.30]$$

where

$$\phi \leq \phi_m \leq 0.9$$

where  $\phi_m$  is the modified value of  $\phi$ .

### A.9 Evaluation of Longitudinal Splices

Once a final cross section is selected, the program proceeds to examine whether the specified type of splice is constructible and then selects the lateral reinforcement. For tied columns a check is made to determine whether the selected reinforcement pattern can be accommodated with either one of the following user specified splices

(Fig. A.6):

1. Bearing
2. Normal lap or Radial
3. Tangential lap

This is accomplished by the following expressions

(ACI Design Handbook Volume 2 - Columns, 1985). For bar diameters ( $d_b$ ) less than or equal to #25 in CAN3-A23.3-M77 and CAN3-A23.3-M84 or #8 in ACI 318-83,

Bearing splices:

$$b_1 = 2(d_c + d_s) + N \times d_b + (N-1)S_{b1} \quad [A.31]$$

Normal splices:



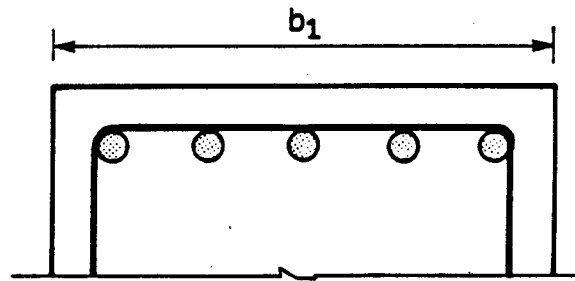

(a) Bearing Splice

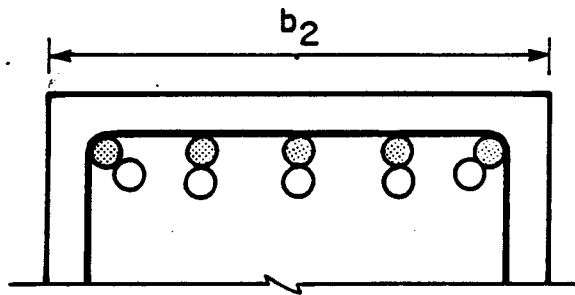

(b) Normal (radial) Lap Splice

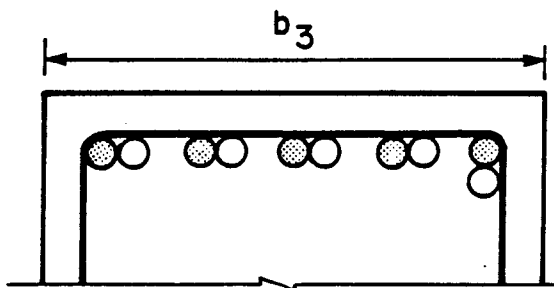

(c) Tangential Lap Splice

Figure A.6 Longitudinal Splices

$$b_2 = b_1 + [(2S_{b_1} + 2d_b) \times \cos\theta - 0.586d_b - 2S_{b_1}] \quad [A.32]$$

where

$$\theta = \arcsin \frac{(1 - \sqrt{0.5})d_b}{S_{b_1} + d_b}$$

**Tangential splices:**

$$b_3 = 2(d_c + d_s) + (2N-1)d_b + (N-1)S_{b_1} \quad [A.33]$$

For bar diameters greater than #25 in CAN3-A23.3-M77 and CAN3-A23.3-M84 or #8 in ACI 318-83,

**Bearing splices:**

$$b_1 = 2(d_c + d_s) + N \times d_b + (N-1)1.5d_b \quad [A.34]$$

**Normal splices:**

$$b_2 = b_1 + 1.38d_b \quad [A.35]$$

**Tangential splices:**

$$b_3 = 2(d_c + d_s) + (2N-1)d_b + (N-1)1.5d_b \quad [A.36]$$

where N is the number of bars on the face with the minimum clear bar spacing,  $S_{b_1}$  is the minimum clear bar spacing and,  $b_1$ ,  $b_2$ , and  $b_3$  are the minimum column dimensions required for accomodating bearing, normal, and tangential splices respectively.

In the case of spiral columns, the maximum number of bars that can be accommodated using the specified splices is determined and checked against the number of bars selected in design. This maximum number of bars is determined using the following expressions. When the bar diameter is less than or equal to #25 in CAN3-A23.3-M77 and CAN3-A23.3-M84 or #8 in ACI 318-83,

Bearing splices:

$$N = \frac{180}{\arcsin[(S_1 + d_b)/(H - d_b - 2(d_c + d_s))]} \quad [A.37]$$

Normal splices:

$$N = \frac{180}{\arcsin[(S_1 + d_b)/(H - 3d_b - 2(d_c + d_s))]} \quad [A.38]$$

Tangential splices:

$$N = \frac{180}{A1 + B1} \quad [A.39]$$

where

$$A1 = \arcsin \frac{(S_{b1} + d_b)}{H - d_b - 2(d_c + d_s)}$$

and

$$B1 = \arcsin \frac{d_b}{H - d_b - 2(d_c + d_s)}$$

When the bar diameter is greater than #25 in CAN3-A23.3-M77 and CAN3-A23.3-M84 or #8 in ACI 318-83,

Bearing splices:

$$N = \frac{180}{\arcsin[(2.5d_b)/(H - d_b - 2(d_c + d_s))]} \quad [A.40]$$

Normal splices:

$$N = \frac{180}{\arcsin[(2.5d_b)/(H - 3d_b - 2(d_c + d_s))]} \quad [A.41]$$

Tangential splices:

$$N = \frac{180}{A1 + B1} \quad [A.42]$$

where

$$A1 = \arcsin \frac{(2.5d_b)}{H - d_b - 2(d_c + d_s)}$$

and

$$B1 = \arcsin \frac{d_b}{H - d_b - 2(d_c + d_s)}$$

A message indicating whether the selected reinforcement can be accomodated with the specified splice is printed.

#### A.10 Lateral Reinforcement

For tied columns, in accordance with code requirements, the program determines the required vertical spacing between the tie sets by computing the least value of:

1.  $16 \times d_b$  (reinforcing bar diameter)
2.  $48 \times d_s$  (lateral tie diameter)
3. the least column dimension ( $c_x$  or  $c_y$ )

To aid the engineer select a feasible tie arrangement, the program prints out the value for the vertical tie spacing computed as shown above together with the-values for the

clear longitudinal bar spacing on both faces ( $S_{bx}$  and  $S_{by}$ ).

The minimum ratio of spiral reinforcement required for a member to qualify as a spiral column has been determined from tests and is specified in the building codes as:

$$\rho_{s \text{ min}} = 4.5 \left[ \frac{A_g}{A_c} - 1 \right] \frac{f'_c}{f_{sy}} \quad [\text{A.43}]$$

where  $f_{sy}$  is the specified yield strength of the spiral reinforcement and  $\rho_s$  is the ratio of spiral reinforcement defined as follows:

$$\begin{aligned} \rho_s &= \frac{\text{Volume of spiral in one loop}}{\text{Volume of core entered by one loop}} \quad [\text{A.44}] \\ &= \frac{\pi d_s^2 (D_c - d_s)}{D_c^2 S} \end{aligned}$$

where  $D_c$  is the diameter of concrete core,  $d_s$  is the lateral spiral diameter, and  $S$  is the maximum spacing between spirals. Equations [A.43] and [A.44] for  $\rho_s$  are used to solve for  $S$ . The minimum number of vertical spacers for spiral reinforcement is also determined in accordance with the code requirements.

## APPENDIX B - USER'S MANUAL

### B.1 Introduction

*COLUMN* is a knowledge-based program for the analysis and design of reinforced concrete columns. The program has been developed for use on an IBM-PC XT/AT microcomputer or a compatible system that operates on MS-DOS (Microsoft Disk Operating System) version 3.x. The system requires a minimum of 512 KB RAM, a 360 KB flexible disk drive, preferably a 10 MB hard drive and a printer device. *COLUMN* is written in MS-FORTRAN (version 4.0); this utilizes the full language standard FORTRAN 77 together with additional MS-FORTRAN metacommands. These metacommands represented by a "\$" character in column one of the source code, are not part of the standard FORTRAN language.

### B.2 General Comments

1. The program can be operated in either a Batch Mode or an Interactive Mode. In Batch Mode, a data file must be created (using an editor such as PE2), whilst in Interactive Mode the program displays prompts for input. The input data is the same for both batch and interactive mode.
2. The input is a free format type, however, real and integer data should be distinguished by the use of the decimal point. In Interactive Mode if the entered data is not in agreement with the required specification, the

prompt is displayed again until the right specification is entered. Each individual entry is separated by a comma, however the comma may be omitted for the last entry of each input.

3. All entries in the input line are required, therefore a 0 should be entered for all parameters for which the default value is to be used or the program is to select. For Interactive Mode processing, the return key must be pressed after a line of data is entered on the terminal keyboard.
4. Except for the heading identifier and the column identification mark, all input character strings should be typed in upper case.
5. The units used in the input are:
  - a. SI units when using CAN3-A23.3-M77 or CAN3-A23.3-M84
  - b. Imperial or U.S. Customary units when using  
ACI 318-83
6. In both Batch and Interactive modes the input data is checked by the program and if errors are detected, the system prompts the error message followed by the recommended action. A list of error messages which arise from input errors is outlined in Section A.

### B.3 Operational Modes

At the start of each run, the program prompts for the type of operational mode.

**MODE** (I)

**MODE** = 0 - Batch Mode  
= 1 - Interactive Mode

### B.4 Data Input

The input datafile for Batch Mode processing comprises 19 lines of input data. Each line is entered in the sequence indicated by the line numbers, as follows:

(a) Heading Recorded:

(1) **HED** (A25)

**HED** = project heading descriptive identifier

(b) Column Identification Record:

(2) **COLID** (A25)

**COLID** = column identification mark

(c) Input Control Design Record:

(3) **DESG, CODE, TYPE** (A)

**DESG** = D - Design Mode (user may specify partial information on column section)  
= C - Check Mode (user has to specify all information on column section)



**CODE** = C77 - CAN3-A23.3-M77  
 = C84 - CAN3-A23.3-M84  
 = A83 - ACI 318-83  
**TYPE** = T - Tied Columns  
 = S - Spiral Columns

(d) Material Properties:

(4) **FPC, FY, FSY** (F)

**FPC** = concrete strength (N/mm<sup>2</sup> or ksi)  
**FY** = yield stress of longitudinal  
 reinforcement (N/mm<sup>2</sup> or ksi)  
**FSY** = yield stress of spiral or lateral steel  
 (N/mm<sup>2</sup> or ksi)

Unit Weight of Concrete:

(5) **MGAMMA** (F)

**MGAMMA** = unit weight of concrete (kg/m<sup>3</sup> or pcf)  
 If 0 is entered the default value is  
 2400 kg/m<sup>3</sup> or 150 pcf

Type of Concrete:

(6) **LAM** (A)

**LAM** = N - Normal density  
 = S - Structural semi-low density  
 = L - Structural low density

(e) Section Geometry Data:

(7) **SHAPE** (A)

**SHAPE** = S - Square  
= R - Rectangular  
= C - Circular

(8) **CX, CY, R** (F)

**CX** = dimension of cross section in the  
x-direction (mm or in.)

**CY** = dimension of cross section in the  
y-direction (mm or in.); if shape = S,  
value of  $c_y$  is not used.

**R** = ratio of  $c_x/c_y$ ; if both  $c_x$  and  $c_y$  are  
entered, R is not the used; when shape  
is not rectangular R defaults to 1.0

(9) **CXINCR, CYINCR, COVER** (F)

**CXINCR** = length increment for dimension  $c_x$  (mm or  
in.); if 0 is entered, default value is  
50 mm or 2 in.

**CYINCR** = length increment for dimension  $c_y$  (mm or  
in.); if 0 is entered, default value is  
50 mm or 2 in.

**COVER** = concrete cover to reinforcement (mm or  
in.); if 0 entered, default value is 40  
mm or 1.5 in.

## General Reinforcement Data:

## (10) RFACE, SPLICE

(A)

- RFACE** = D - reinforcement pattern to be selected by program
- = X - reinforcement arranged in x-faces (end faces) only (Fig A.2)
- = Y - reinforcement arranged in y-faces (lateral faces) only (Fig A.2)
- = B - reinforcement placed on both the x and y faces
- = C - reinforcement placed in a circular arrangement
- SPLICE** = B - bearing splice
- = R - radial splice
- = T - tangential splice

## Reinforcement Ratio

## (11) PG

(F)

- PG** = maximum percentage of reinforcement ( $0.1 \leq PG \leq 0.08$ ). If entered PG = 0.0 then default is 0.03

## Reinforcing Bars (a):

(12) **BMAX, NX, NY** (I)

- BMAX** = allowable maximum number of bars, if 0 is entered this is selected by program
- NX** = number of bars in each x-face, including corner bars
- NY** = number of bars in each y-face, if bars on all faces NY does not include corner bars

## Reinforcing Bars (b):

(13) **BSMI, BSMA, LR** (I)

- BSMI** = minimum bar size, number 15 to 55 for CAN3-A23.3-M77 and CAN3-A23.3-M84 or 5 to 18 for ACI 318-83; if 0 is entered the default is 15 or 5
- BSMA** = maximum bar size, number 15 to 55 for CAN3-A23.3-M84 or 5 to 18 for ACI 318-83; if 0 is entered the default is 35 or 11
- LR** = minimum lateral reinforcing bar size number; if 0 is entered the default is 10 for CAN3-A23.3-M77 and CAN3-A23.3-M84, or 3 for ACI 318-83

(f) Loading Geometry:

Loading Type:

(14) **FACT** (A)

**FACT** = U - unfactored  
= F - factored

Axial Loading:

(15) **PD, PL** (F)

**PD** = axial dead load - must be positive (kN  
or kips)  
**PL** = axial live load - must be positive (kN  
or kips)

Moments Acting at Top of Column (see sign convention  
Section A.1):

(16) **MDXT, MLXT, MDYT, MLYT** (F)

**MDXT** = dead load moment about x-axis acting at  
the top of column (kNm or kips.ft)  
**MLXT** = live load moment about x-axis acting at  
the top of column (kNm or kips.ft)  
**MDYT** = dead load moment about y-axis acting at  
the top of column (kNm or kips.ft)  
**MLYT** = live load moment about y-axis acting at  
the top of column (kNm or kips.ft)

Moments Acting at Bottom of Column:

(17) MDXB, MLXB, MDYB, MLYB (F)

- MDXB = dead load moment about x-axis acting at the bottom of column (kNm or kips.ft)
- MLXB = live load moment about x-axis acting at the bottom of column (kNm or kips.ft)
- MDYB = dead load moment about y-axis acting at the bottom of column (kNm or kips.ft)
- MLYB = live load moment about y-axis acting at the bottom of column (kNm or kips.ft)

(g) Stability Data:

About the x-axis:

(18) XBRAC, KX, LUX (I,F,F)

- XBRAC = 0 - column unbraced about x-axis  
 = 1 - column braced about x-axis
- KX = effective length factor about the x-axis
- LUX = unsupported length about the x-axis (mm or in.)

About the y-axis:

(19) YBRAC, KY, LUY (I,F,F)

- YBRAC = 0 - column unbraced about y-axis  
 = 1 - column braced about y-axis
- KY = effective length factor about the y-axis
- LUY = unsupported length about the y-axis (mm or in.)

## B.5 Running the Program

Once the program is mounted, to run *COLUMN* enter the command COL at the disk drive prompt. The program then prompts for the type of operational mode (see Section B.3). If 0 is entered (Batch Mode) the user is requested to enter the name of a file that contains the input data. This file must be created by the user prior to running the program and must exist in the current directory. The user is also prompted for the name of the output file into which the results are to be stored. The specified name for the output file must not exist in the current directory. This file is created automatically by the program. If 1 is entered (Interactive Mode) only the filename for output of results is required.

The output file which includes the results can be viewed on the screen by entering edit mode. The output can be scrolled by using the pg up and pg dn keys. To get a hard copy of the output results on the printer, type the command LPR <output-filename>.

The above steps are described in the following sample run. In this example COLEX.INP is the name of the input data file in the current directory and COLEX.OUT is the name assigned to the output file. It is assumed that the executable file (COL.EXE) and the input file are in drive A. The input commands are indicated in bold characters.

## B.6 Sample Run

(1) user

<A:/>COL

program

MODE: TYPE 0 FOR BATCH OR 1 FOR INTERACTIVE

THEN PRESS RETURN KEY

(2) user

0

program

ENTER INPUT DATA FILE NAME

(3) user

COLEX.INP

program

ENTER OUTPUT DATA FILE NAME

(4) user

COLEX.OUT

program

Stop - Program terminated

(5) user - to view the output results on the screen using  
for example PE2 (personal editor 2)

<A:/>PE COLEX.OUT

(6) user - to get a hardcopy of the output

<A:/>LPR <COLEX.OUT

LPR (Line PRinter) is a program written in C that interprets  
the output for *COLUMN* and lays out the format of the output.



**B.7 Diagnostic Messages**

- ERROR #C001...INVALID MODE ENTERED  
ACTION: SPECIFY MODE AGAIN  
TYPE 0 FOR BATCH OR 1 FOR INTERACTIVE
- ERROR #C002...INVALID TYPE OF PROBLEM ENTERED  
ACTION: SPECIFY TYPE OF PROBLEM AGAIN  
TYPE D FOR DESIGN MODE  
TYPE C FOR CHECK MODE
- ERROR #C003...INVALID CODE ENTERED  
ACTION: ENTER CODE AGAIN  
TYPE C77 FOR CAN3-A23.3-M77  
TYPE C84 FOR CAN3-A23.3-M84  
TYPE A83 FOR ACI 318-83
- ERROR #C004...INVALID COLUMN TYPE ENTERED  
ACTION: ENTER COLUMN TYPE AGAIN  
TYPE T FOR TIED COLUMN  
TYPE S FOR SPIRAL COLUMN
- WARNING #C005...Fy ENTERED < ALLOWABLE MINIMUM Fy  
MINIMUM Fy = 250.0 kN/mm<sup>2</sup> or 35.0 ksi  
ACTION: ENTER Fy OF LONGITUDINAL STEEL AGAIN
- WARNING #C006...Fy ENTERED > ALLOWABLE MAXIMUM Fy  
MAXIMUM Fy = 500.0 kN/mm<sup>2</sup> or 75.0 ksi  
ACTION: ENTER Fy OF LONGITUDINAL STEEL AGAIN
- WARNING #C007...Fy ENTERED < ALLOWABLE MINIMUM Fy  
MINIMUM Fy = 250.0 kN/mm<sup>2</sup> or 35.0 ksi  
ACTION: ENTER Fy OF SPIRAL STEEL AGAIN
- WARNING #C008...Fy ENTERED > ALLOWABLE MAXIMUM Fy  
MAXIMUM Fy = 500.0 kN/mm<sup>2</sup> or 75.0 ksi  
ACTION: ENTER Fy OF SPIRAL STEEL AGAIN
- WARNING #C009...F'c ENTERED < ALLOWABLE MINIMUM F'c  
MINIMUM F'c = 15.0 kN/mm<sup>2</sup> or 2.0 ksi  
ACTION: ENTER F'c AGAIN
- WARNING #C010...F'c ENTERED > ALLOWABLE MAXIMUM F'c  
MAXIMUM F'c = 60.0 kN/mm<sup>2</sup> or 6.0 ksi  
ACTION: ENTER F'c AGAIN

ERROR #C011...INVALID CONCRETE TYPE ENTERED  
ACTION: INDICATE TYPE OF CONCRETE AGAIN  
TYPE N FOR NORMAL DENSITY CONCRETE  
TYPE S FOR STRUCTURAL SEMI-LOW DENSITY  
CONCRETE  
TYPE L FOR STRUCTURAL LOW DENSITY CONCRETE

ERROR #C012...INVALID COLUMN TYPE ENTERED  
ACTION: ENTER COLUMN TYPE AGAIN  
TYPE S FOR SQUARE  
TYPE R FOR RECTANGULAR  
TYPE C FOR CIRCULAR

WARNING #C013...RECTANGULAR SHAPE IS NOT PERMITTED  
SINCE LATERAL REINFORCEMENT SPECIFIED IS  
SPIRAL  
ACTION: ENTER COLUMN TYPE AGAIN  
TYPE S FOR SQUARE  
TYPE C FOR CIRCULAR

WARNING #C014...ENTERED COLUMN DIMENSION IN THE  
X - DIRECTION  
MUST BE EQUAL TO DIMENSION IN THE  
Y - DIRECTION  
SINCE A SQUARE COLUMN SECTION HAS BEEN  
SPECIFIED  
ACTION: THE PROGRAM DEFAULTS VALUE OF  $C_y = C_x$

WARNING #C015...ENTERED  $C_x <$  ALLOWABLE MINIMUM  $C_x$   
MINIMUM COLUMN DIMENSION = 200 mm or 8 in.  
ACTION: ENTER NEW COLUMN DIMENSION  $C_x$

WARNING #C016...ENTERED  $C_y <$  ALLOWABLE MINIMUM  $C_y$   
MINIMUM COLUMN DIMENSION = 200 mm or 8 in.  
ACTION: ENTER NEW COLUMN DIMENSION  $C_y$

ERROR #C017...INVALID REINFORCEMENT PATTERN ENTERED  
ACTION: SPECIFY REINFORCEMENT PATTERN AGAIN  
TYPE D FOR DESIGN BY PROGRAM  
TYPE X FOR X - FACES  
TYPE Y FOR Y - FACES  
TYPE B FOR BOTH FACES  
TYPE C FOR CIRCULAR

WARNING #C018...REINFORCEMENT PATTERN CANNOT BE  
CIRCULAR SINCE SPECIFIED SHAPE OF COLUMN IS  
RECTANGULAR  
ACTION: SPECIFY REINFORCEMENT PATTERN AGAIN  
TYPE X FOR X - FACES  
TYPE Y FOR Y - FACES  
TYPE B FOR BOTH FACES

ERROR #C019...INVALID TYPE OF SPLICE ENTERED  
ACTION: ENTER TYPE OF SPLICE AGAIN  
TYPE B FOR BEARING SPLICE  
TYPE R FOR RADIAL (NORMAL) SPLICE  
TYPE T FOR TANGENTIAL SPLICE

WARNING #C020...ENTERED REINFORCEMENT RATIO IS  
NOT WITHIN MAX. AND MIN. LIMITS  
MAXIMUM REINFORCEMENT RATIO = 0.08  
MINIMUM REINFORCEMENT RATIO = 0.01  
ACTION: ENTER REINFORCEMENT RATIO AGAIN

WARNING #C021...ENTERED NUMBER OF BARS IS SMALLER  
THAN ALLOWABLE MINIMUM NUMBER OF BARS  
MIN. NO. OF BARS = 4 FOR RECTANGULAR  
MIN. NO. OF BARS = 6 FOR CIRCULAR  
ACTION: ENTER MAXIMUM PERMISSABLE No. OF BARS

ERROR #C022...MAXIMUM BAR SIZE CANNOT BE LESS  
MINIMUM BAR SIZE  
ACTION: ENTER MAXIMUM BAR SIZE AGAIN

ERROR #C023...INVALID LOADING TYPE ENTERED  
ACTION: SPECIFY TYPE OF LOADING AGAIN  
TYPE U FOR UNFACTORED  
TYPE F FOR FACTORED

ERROR #C024...WRONG SPECIFICATION OF BRACING  
CONDITION ABOUT THE X-AXIS or Y-AXIS  
ACTION: SPECIFY BRACING CONDITIONS ABOUT THE (X-AXIS  
or Y-AXIS)  
TYPE 0 FOR UNBRACED  
TYPE 1 FOR BRACED

WARNING #C025...ENTERED EFFECTIVE LENGTH FACTOR  
FOR BRACED COLUMN ABOUT X-AXIS  
IS NOT WITHIN PRACTICAL LIMITS  
 $0.5 < K_x < 1.0$   
ACTION: ENTER EFFECTIVE LENGTH FACTOR ( $K_x$ )

WARNING #C026...ENTERED EFFECTIVE LENGTH FACTOR  
FOR BRACED COLUMN ABOUT Y-AXIS  
IS NOT WITHIN PRACTICAL LIMITS  
0.5 <  $K_y$  < 1.0  
ACTION: ENTER EFFECTIVE LENGTH FACTOR ( $K_y$ )

WARNING #C027...ENTERED EFFECTIVE LENGTH FACTOR  
FOR UNBRACED COLUMN ABOUT X-AXIS  
IS < 1.0  
ACTION: ENTER EFFECTIVE LENGTH FACTOR ( $K_x \geq 1.0$ )>

WARNING #C028...ENTERED EFFECTIVE LENGTH FACTOR  
FOR UNBRACED COLUMN ABOUT Y-AXIS  
IS < 1.0  
ACTION: ENTER EFFECTIVE LENGTH FACTOR ( $K_y \geq 1.0$ )>

**B.8 Summary of Flags Used in Program****(a) Operational Mode Default Flags**

**TMODE** = 0 - Batch mode  
= 1 - Interactive mode

**(b) Code Default Flags**

**TCODE** = 1 - CSA CAN3-A23.3-M77  
= 2 - CSA CAN3-A23.3-M84  
= 3 - ACI 318-83

**(c) Problem Mode**

**TDESG** = 1 - Design mode  
= 2 - Check mode

**(d) Type Of Column Default Flags**

**TYPE** = 0 - Spiral column  
= 1 - Tied column

**(e) Shape Of Column Default Flags**

**TSHAPE** = 1 - Square  
= 2 - Rectangular  
= 3 - Circular

**(f) Type Of Splice Default Flags**

**TSPLIC** = 1 - Bearing splice  
= 2 - Radial splice  
= 3 - Tangential splice

**(g) Type Of Bending Default Flags**

**TLFLAG** = 0 - Axial loading  
= 1 - Uniaxial bending about y-axis  
= 2 - Uniaxial bending about x-axis  
= 3 - Biaxial bending

(h) Type Of Loads Default Flags

**TFACT** = 1 - Unfactored loads  
= 2 - Factored loads

(i) Reinforcement Pattern Default Flags

**TRFACE** = 1 - Not specified  
= 2 - On x-faces  
= 3 - On y-faces  
= 4 - On both faces  
= 5 - Circular

(j) Dimensions Default Flags

**TDIMFG** = 0 - Nothing entered  
= 1 -  $c_x$  only entered  
= 2 -  $c_y$  only entered  
= 3 -  $c_x/c_y$  - (R) only entered  
= 4 -  $c_x$  and  $c_y$  known

(k) Type Of Bracing Default Flags

**TXBRAC** = 0 - Unbraced about x-axis  
= 1 - Braced about x-axis  
**TYBRAC** = 0 - Unbraced about y-axis  
= 1 - Braced about y-axis

RECENT STRUCTURAL ENGINEERING REPORTS

Department of Civil Engineering

University of Alberta

121. *Standardized Flexible End Plate Connections for Steel Beams* by G.J. Kriviak and D.J.L. Kennedy, December 1984.
122. *The Effects of Restrained Shrinkage on Concrete Slabs* by K.S.S. Tam and A. Scanlon, December 1984.
123. *Prestressed Concrete Beams with Large Rectangular Web Openings* by T. do M.J. Alves and A. Scanlon, December 1984.
124. *Tests on Eccentrically Loaded Fillet Welds* by G.L. Kulak and P.A. Timler, December 1984.
125. *Analysis of Field Measured Deflections Scotia Place Office Tower* by A. Scanlon and E. Ho, December 1984.
126. *Ultimate Behaviour of Continuous Deep Reinforced Concrete Beams* by D.R. Ricketts and J.G. MacGregor, January 1985.
127. *The Interaction of Masonry Veneer and Steel Studs in Curtain Wall Construction* by W.M. McGinley, J. Warwaruk, J. Longworth and M. Hatzinikolas, May 1985.
128. *Evaluation of Existing Bridge Structure by Nondestructive Test Methods* by L. Mikhailovsky and A. Scanlon, May 1985.
129. *Finite Element Modelling of Buried Structures* by D.K. Playdon and S.H. Simmonds, October 1985.
130. *Behaviour and Ultimate Strength of Transversely Loaded Continuous Steel Plates* by K.P. Ratzlaff and D.J.L. Kennedy, November 1985.
131. *Inelastic Lateral Buckling of Steel Beam-Columns* by P.E. Cuk, M.A. Bradford and N.S. Trahair, December 1985.
132. *Design Strengths of Steel Beam-Columns* by N.S. Trahair, December 1985.
133. *Behaviour of Fillet Welds as a Function of the Angle of Loading* by G.S. Miazga and D.J.L. Kennedy, March 1986.
134. *Inelastic Seismic Response of Precast Concrete Large Panel Coupled Shear Wall Systems* by M.R. Kianoush and A. Scanlon, March 1986.
135. *Finite Element Prediction of Bin Loads* by A.H. Askari and A.E. Elwi, June 1986.

136. *Shear Behavior of Large Diameter Fabricated Steel Cylinders* by J. Mok and A.E. Elwi, June 1986.
137. *Local Buckling Rules for Structural Steel Members* by S. Bild and G.L. Kulak, May 1986.
138. *Finite Element Prediction of Reinforced Concrete Behavior* by S. Balakrishnan and D.W. Murray, July 1986.
139. *Behavior and Strength of Masonry Wall/Slab Joints* by T.M. Olatunji and J. Warwaruk, July 1986.
140. *Bayesian Analysis of In-Situ Test Data for Estimating the Compressive Strength of Concrete in Existing Structures* by G.J. Kriviak and A. Scanlon, July 1986.
141. *Shear-Moment Transfer in Slab-Column Connections* by S.D.B. Alexander and S.H. Simmonds, July 1986.
142. *Minimum Thickness Requirements for Deflection Control of Two-Way Slab Systems* by D.P. Thompson and A. Scanlon, November 1986.
143. *Shrinkage and Flexural Tests of Two Full-Scale Composite Trusses* by A. Brattland and D.J.L. Kennedy, December 1986.
144. *Combined Flexure and Torsion of I-Shaped Steel Beams* by R.G. Driver and D.J.L. Kennedy, March 1987.
145. *Cyclic and Static Behaviour of Thin Panel Steel Plate Shear Walls* by E.W. Tromposch and G.L. Kulak, April 1987.
146. *Postbuckling Behavior of Thin Steel Cylinders Under Transverse Shear* by V.G. Roman and A.E. Elwi, May 1987.
147. *Incipient Flow in Silos - A Numerical Approach* by R.A. Link and A.E. Elwi, May 1987.
148. *Design of Web-Flange Beam or Girder Splices* by D. Green and G.L. Kulak, May 1987.
149. *Spreadsheet Solution of Elastic Plate Bending Problems* by G.E. Small and S.H. Simmonds, July 1987.
150. *Behaviour of Transversely Loaded Continuous Steel-Concrete Composite Plates* by S.J. Kennedy and J.J. Cheng, July 1987.
151. *Behaviour and Ultimate Strength of Partial Joint Penetration Groove Welds* by D.P. Gagnon and D.J.L. Kennedy, July 1987.
152. *KBES for Design of Reinforced Concrete Columns* by A. Bezzina and S.H. Simmonds, July 1987.