

Design of a Braided Composite Badminton Racket on Solidworks

Mackenzie Neufeld, Ahmed Samir Ead, Eric Lepp, Jason Carey
Department of Mechanical Engineering, University of Alberta

Objective

To create and model an efficient design of a badminton racket in order to build a prototype out of Kevlar® braided composites.

Introduction

- Badminton rackets are typically made of steel, aluminum or carbon fiber.
- Kevlar is a heat resistant and high strength synthetic fiber [1].
- In order to create an efficient racket, the frame must be flexible, strong, and durable - but light.

Methods

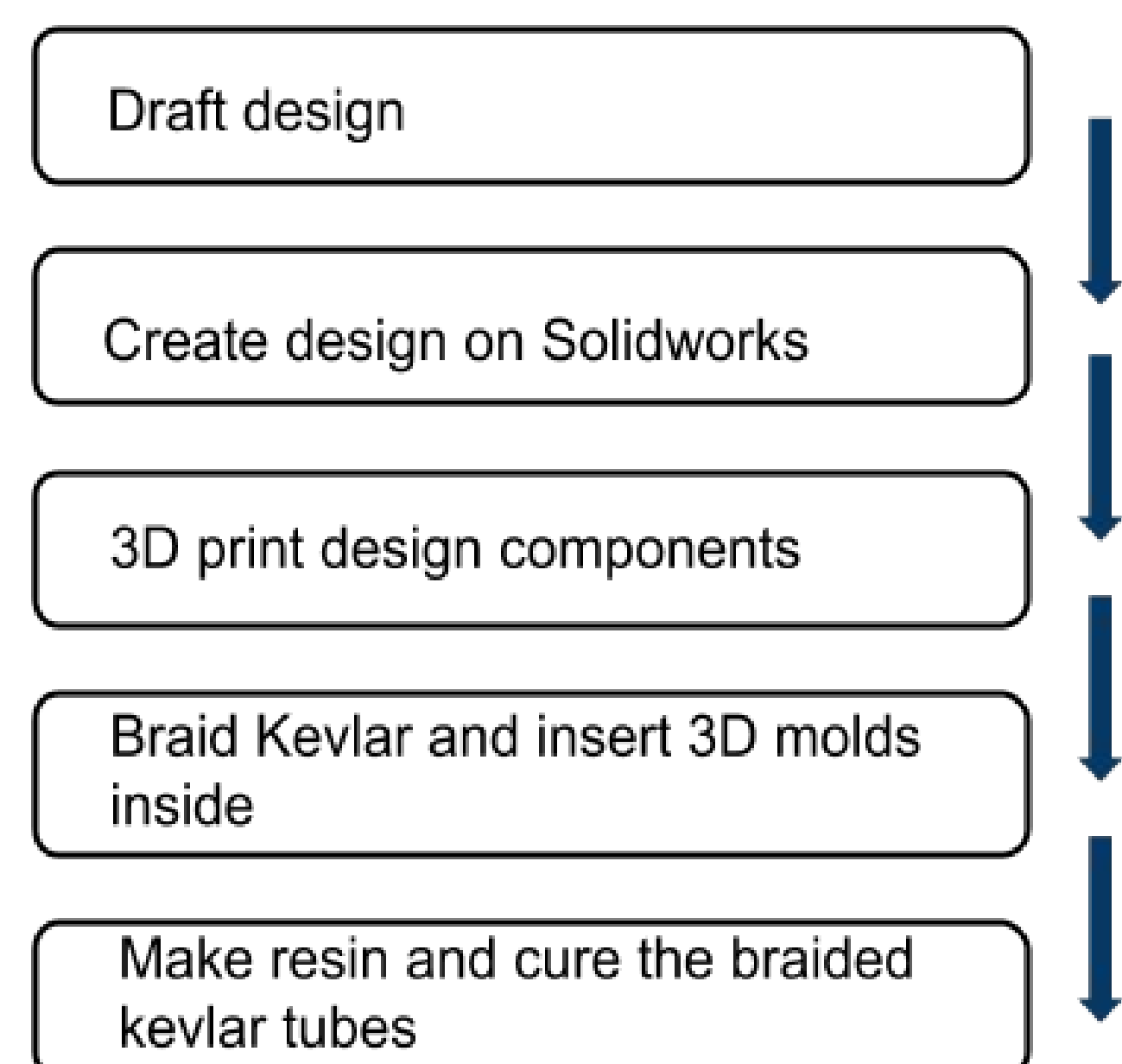

Design Process

- Modeling the racket on Solidworks allows designers to check the geometric and manufacturing feasibility of the product.
- In order to design and 3D print feasible racket components, it must be broken down to various parts. An exploded view of the model racket is shown with its various components in Figure 1. This requires the designer to create connector parts to attach to these components (as shown in Figure 2).
- This model mimics the ideal Kevlar prototype.

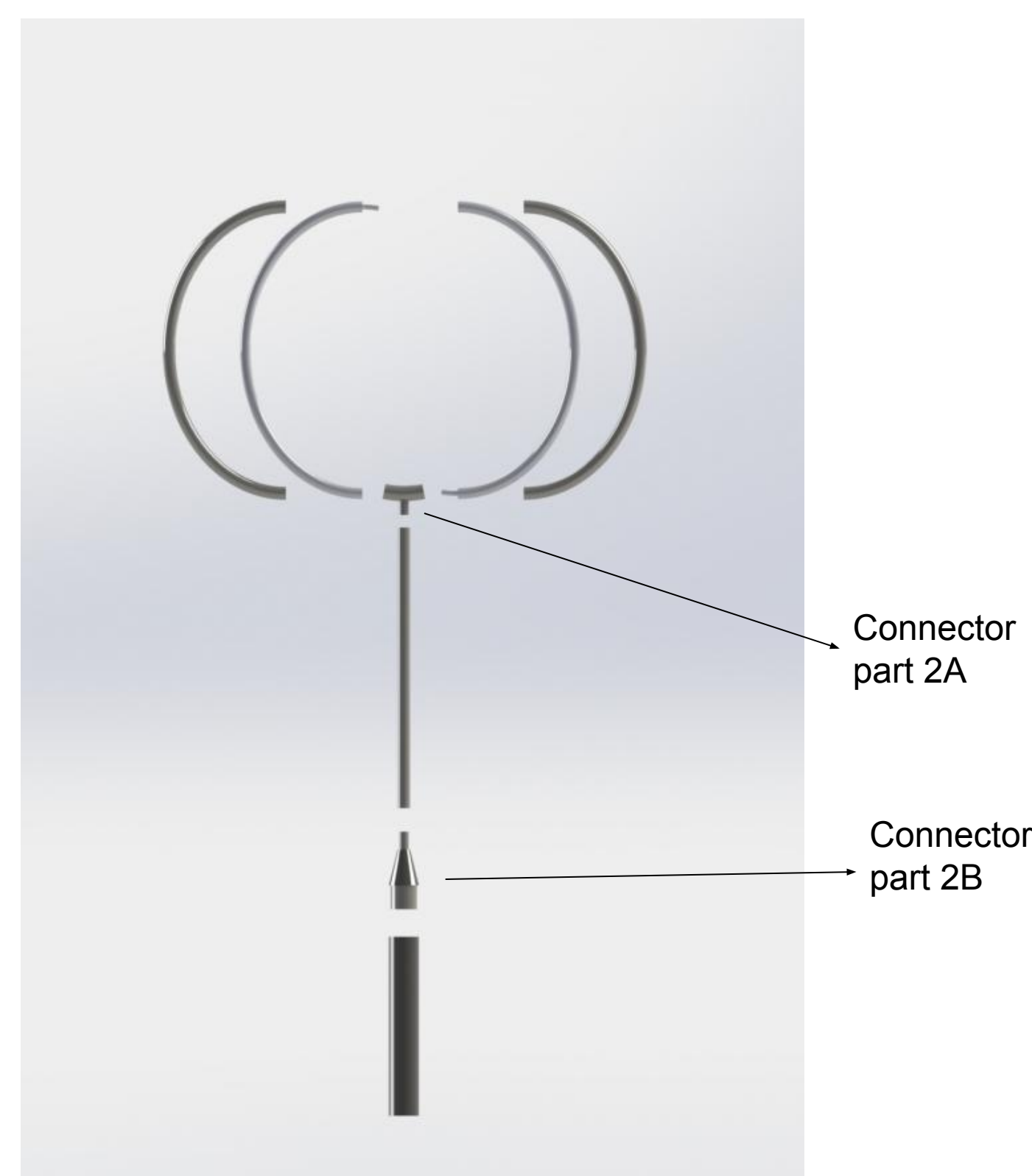

Figure 1: Exploded view of racket

Racket Head

- Two solid half ellipses were modeled, acting as a skeleton for the racket.
- On the ends of each half ellipse there is either a hole or an extrusion. This allows for a secure connection between the pieces.
- In order to mimic the composite braid that would encase the 3D skeleton, a hollow half ellipse with a slightly larger diameter was needed. These components were attached to the handle using the connector shown in Figure 2A.

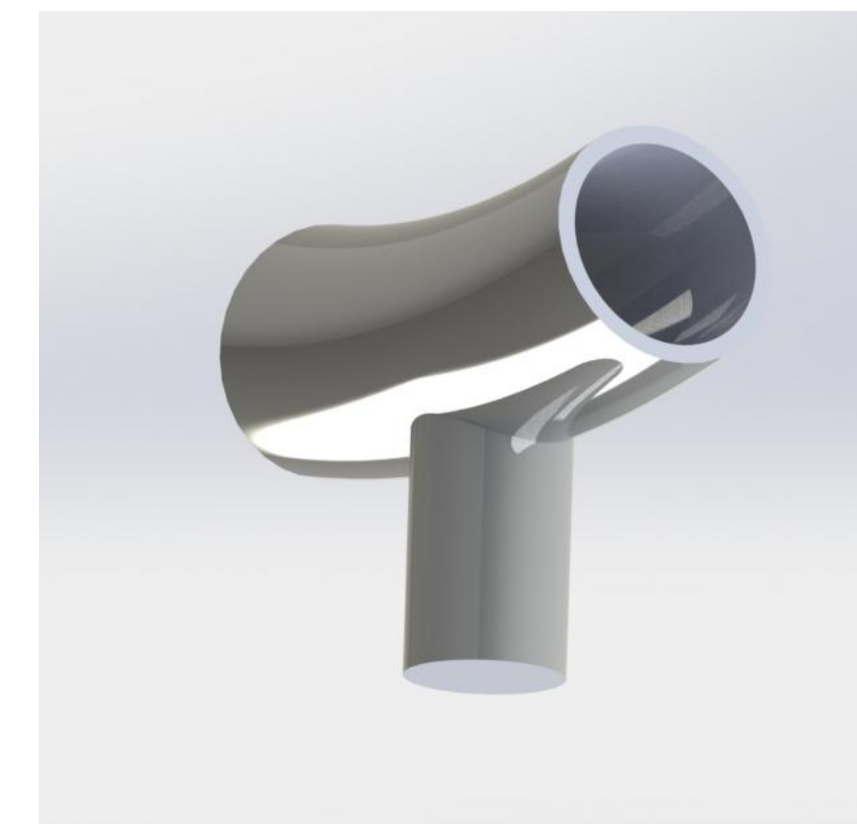

Figure 2A: The connector which attaches the racket head pieces to the handle

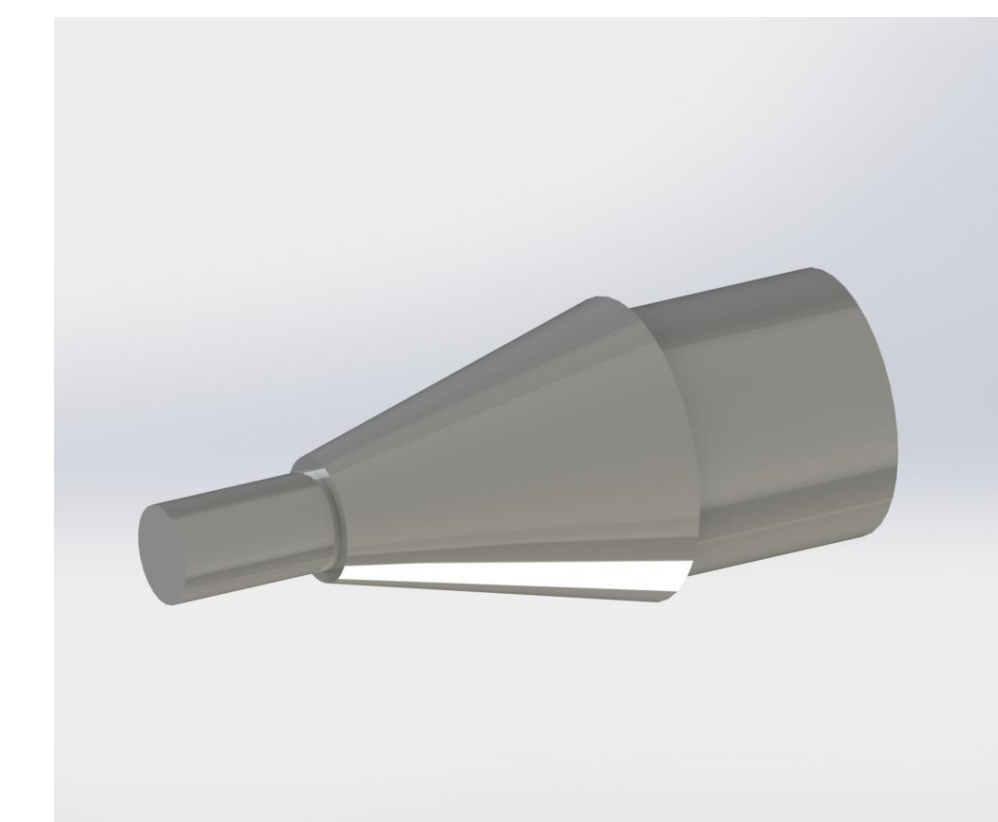

Figure 2B: The connector which attaches the rod to the grip

Racket Handle

- In order to make the handle, two separate braids of Kevlar were cured with composite resin on a mandrel with an appropriate diameter.
- They were attached to each other using the connector shown in Figure 2B.

Braiding and Curing Process

1. Braid Kevlar using the maypole braiding system
2. Slide the braid onto the appropriate curing mandrel
3. Prepare composite resin- Take 10g of resin (Ecopoxy A) and mix with 10g of hardener (Ecopoxy B)
4. Apply resin to braid with syringe and evenly distribute across the specimen using gloves
5. Leave to harden
6. Once hardened, cut parts to appropriate length and attach to form racket



Figure 3: The resin application process of Kevlar braids on various curing mandrels



Figure 4: A sample of a cured braid of Kevlar

Material Significance [2]

Materials	Pros	Cons
Kevlar	<ul style="list-style-type: none"> - Better strength to weight ratio than carbon fiber - 5 times stronger than steel - Lighter than steel - Resists effects of naturally occurring chemicals 	<ul style="list-style-type: none"> - High flex resistance - Once cured it can only be pierced with specific drills - Not recyclable
Carbon Fiber	<ul style="list-style-type: none"> - Good strength to weight ratio - Extremely flexible - High heat resistance 	<ul style="list-style-type: none"> - Not recyclable - Labor intensive to manufacture - Expensive
Aluminum and Steel	<ul style="list-style-type: none"> - Strong - Recyclable 	<ul style="list-style-type: none"> - Stiff - High density

Conclusion

- Currently Kevlar is used for bulletproof vests, car brakes, boats, or in aerospace engineering
- In order to be used in the sporting good industry, braided Kevlars would have to be produced with an enhanced flexibility
- This may require the application of variations of thermoplastic resin which allows for more compliance in flex (lower modulus)
- To produce braided Kevlar in smaller scales - lower density braiders are required.

References

- [1] "Carbon Fibre versus Kevlar Material | Which one is the Best for you?", *Tricel Composites*, 2019. [Online]. Available: <https://www.tricelcomposites.co.uk/blog-carbon-fibre-vs-kevlar/>. [Accessed: 06- Aug- 2019].
- [2] "Kevlar", Elsevier, last modified 2019, <https://www.sciencedirect.com/science/article/pii/B9781845696276500019>

Acknowledgements

Thank you to both Canada Summer Jobs and the Society of Petroleum Engineering for sponsoring me this summer - I wouldn't have this amazing opportunity if it weren't for your generous support.

Thank you to my PI Jason Carey, my supervisors Samir and Eric, and the members of my lab: Ross, Xiao, Sissi, Ahmed, and Bill who all heightened this experience to its full potential.

Thank you to the WISEST team for giving myself and other like-minded students this wonderful opportunity express our passion for science - this experience will be cherished forever.