

THE UNIVERSITY OF ALBERTA

A SYSTEMS MODEL FOR

APPRENTICESHIP

TRAINING

by



THOMAS WILLIAM BROAD

A THESIS

SUBMITTED TO THE FACULTY OF GRADUATE STUDIES AND RESEARCH

IN PARTIAL FULFILMENT OF THE REQUIREMENTS FOR THE DEGREE

OF MASTER OF EDUCATION

DEPARTMENT OF INDUSTRIAL AND VOCATIONAL EDUCATION

EDMONTON, ALBERTA

FALL, 1972.

ABSTRACT

This study embraced the development of a systems model for apprenticeship training and the application of the model to a few training situations in the apprenticeship scheme that is extant in Alberta at this time.

The model was developed from a general training model and adapted to suit the evolving concept of apprenticeship training. This concept is that the apprentice will select different blocks or modules of training to suit his particular job.

These different blocks are seen as job-centred training. That is the training course is developed from an actual job analysis. From job analyses for different trades behavioral objectives are developed, and in turn from these objectives the development of performance objectives as well as training objectives is carried out.

The function of the training authority, according to the model, in Alberta this is the Provincial Apprenticeship Board, is to perform a quality control function. This is to ensure that the quality of tradesmen developed through apprenticeship training is maintained at a consistently high quality. The meaning here of quality does not necessarily infer the possession of solid, but outdated hand skills, but rather equipping a tradesman with the skills required by him for his job as technology advances. These skills envelop the complete spectrum from the purely manipulative skills to the purely heuristic.

The model as developed agrees with the proposals of a number of eminent scholars in the science of education as well as modern

notions in industrial training. That is, the ideas expressed in the model are not new. What might be new is the synthesis of contemporary ideas from industrial training, with up-to-date thinking from the field of educational endeavour and from sociology. This synthesis has, perhaps, resulted in an organic whole that is the systems approach to apprenticeship training.

The part of the study, that was the application of the model, used some ten different methods for assessing some aspects of the training situations. Some of these methods are standard in this type of study; others are regarded as unique.

The conclusion of the study is that the use of the systems approach to apprenticeship training, if job-centred as outlined in this model, will tend, possibly significantly, to reduce some of the defects in apprenticeship training that have been pointed out in recent years.

ACKNOWLEDGEMENT

This study has been supported by a grant-in-aid from the Alberta Human Resources Research Council.

I am indebted for the assistance given to me by: so many of my colleagues at the Northern Alberta Institute of Technology; the many apprentices who assisted me in the study in many different ways, and who gave me encouragement; the many individuals at Headquarters Training Command, Canadian Forces, Winnipeg, who assisted me and who attempted to provide answers for the numerous questions that I posed; Fred Whittle, Director, and the staff of the Provincial Apprenticeship Board, Alberta Department of Labour for their co-operation; Professor M. Petruk, Dr. J.F.D. Ilott, Dr. V. Nyberg, and Dr. G. Rose of the University of Alberta for their advice and criticism; and my wife Louise without whose untiring help, criticism, and encouragement this study would not have been completed.

TABLE OF CONTENTS

	Page
LIST OF TABLES.....	x
LIST OF FIGURES.....	xi
Chapter	
1. BACKGROUND AND STATEMENT OF PROBLEM.....	1
Introduction.....	1
Apprenticeship in Alberta.....	2
Manpower Development and Apprenticeship Training.....	4
Statement of Problem.....	7
Purpose of the Study.....	8
Need for the Study.....	9
Delimitation of the Study.....	10
Limitations of the Study.....	10
Definition of terms.....	10
2. SEARCH OF THE LITERATURE.....	12
A Model.....	12
System Research.....	17
Skilled Behavior.....	18
Job Analysis.....	22
Attitude.....	24
Training.....	26
On-the-job Training.....	30
Aptitude Testing.....	34
Merit Rating of Apprentices.....	38
Examinations.....	42

Chapter	Page
2.	External Examinations..... 51
	Evolving Ideas of Apprenticeship..... 53
	Summary..... 57
3.	DEVELOPMENT OF THE MODEL..... 60
	Approach to the Study..... 61
	Results of the Enquiries..... 62
	The Objectives of Apprenticeship Training.... 63
	Training Models..... 65
	Basic Model..... 66
	Analyze Trade, Subsystem 1.0..... 68
	Establish Terminal Objectives, Subsystem 2.0..... 68
	Select Apprentices, Subsystem 3.0..... 73
	Develop Training Courses, Subsystem 4.0..... 77
	Implement Training, Subsystem 5.0..... 79
	Administer Results, Subsystem 6.0..... 80
	Monitor Effectivity of Training, Subsystem 7.0..... 82
	Conduct Experimental Training, Subsystem 8.0..... 84
	Conclusion..... 84
4.	APPLICATION OF THE MODEL..... 85
	An Examination of the Validity of the Training Course Given to First-year Cooks..... 88
	An Independent Study of the Second-year Radio-T.V. Technician Examination of the Provincial Apprenticeship Board..... 89

Chapter	Page
4.	
A Review of the Provincial Apprenticeship Board Examination for Third-year Level Plumbing Apprentices.....	92
Fourth-year Automotive Mechanics	
Evaluation of Apprentices by Supervisors...	96
Evaluation of the Work Situation.....	99
Weighted Performance of Apprentices.....	100
Rating of Apprentices by Forced-distribution Method.....	101
Rating of Apprentices by Their Peers.....	102
Rating of Apprentices by the Shop Instructor.....	103
Rating of Apprentices by The Provincial Apprenticeship Board.....	104
Correlations.....	104
The Apprentices' View of Examinations.....	104
5. ANALYSIS OF RESULTS.....	107
The Model.....	108
An Examination of the Validity of the Training Course Given to First-year Cooks.....	109
An Independent Study of the Second-year Radio-T.V. Technician Examination of The Provincial Apprenticeship Board.....	110
A Review of the Provincial Apprenticeship Board Examination for Third-year Level Plumbing Apprentices.....	111
Evaluation of the Work Situation.....	113
Weighted Performance of Apprentices.....	115
The Correlation Matrix.....	116
The Apprentices' Views Of Examinations.....	117

Chapter	Page
6. SUMMARY AND CONCLUSIONS.....	119
Summary.....	119
Conclusions.....	121
Recommendations for Further Study.....	122
Bibliography.....	125
Appendix	
A INFORMATION FROM THE CANADIAN FORCES.....	136
B A SURVEY OF FIRST-YEAR COOK APPRENTICES.....	140
C AN INDEPENDENT REVIEW OF THE EXAMINATION FOR SECOND-YEAR RADIO-T.V. APPRENTICES.....	148
D AN ITEM ANALYSIS OF THE EXAMINATION FOR THIRD-YEAR PLUMBING APPRENTICES.....	154
E THE EVALUATION OF APPRENTICES BY SUPERVISORS.....	158
F THE EVALUATION OF THE WORK SITUATION.....	165
G CRITERION (THE WEIGHTED PERFORMANCE OF APPRENTICES).....	170
H THE RATING OF APPRENTICES BY FORCED-DISTRIBUTION, BY PAIRS, BY SHOP INSTRUCTORS' MARKS, AND BY APPRENTICESHIP BOARD MARKS.....	172
I CONSOLIDATED TABLE AND CORRELATION MATRIX.....	178
J THE APPRENTICES' VIEWS OF EXAMINATIONS.....	181

LIST OF TABLES

Table		Page
B-1	Selection of Alternative Responses to the Question "How Often Do You Perform This Task" by First-year Apprentice Cooks.....	144
B-2	Selection of Alternative Responses to the Question "Was Your First-year Training Adequate For This Task" by First-year Apprentice Cooks.....	146
C-1	Second-year Radio-T.V. Technician Examination, Distribution of Questions According to Subject Division.....	153
D-1	Third Year Examination Plumber Apprentice, Plumbing Section, Item Analysis Multiple-Choice Questions.....	155
D-2	Third Year Examination Plumber Apprentice, Gasfitting Section, Item Analysis Multiple-Choice Questions.....	156
E-1	The Evaluation of Apprentices by Their Supervisors.....	164
F-1	The Evaluation of the Work Situation.....	168
F-2	Garages Listed By Characteristics.....	169
F-3	Rating of Garages By Characteristics.....	169
G-1	Criterion (Weighted Performance of Apprentices).....	171
H-1	Shop Instructors' Rating of Apprentices By Forced-Distribution Method.....	176
H-2	Rating of Apprentices By Their Peers, The Marks Given By Shop Instructors, And The Mark Obtained By Each Apprentice On The Apprenticeship Board Examination.....	177
I-1	Consolidated Table Of Ratings And Marks.....	179
I-2	Correlation Matrix Of Ratings And Marks.....	180

LIST OF FIGURES

Figure		Page
1	A Model of Apprenticeship Training.....	67
2	Subsystems 1.0 and 2.0 of the Model.....	70
3	Subsystems 3.0 and 4.0 of the Model.....	76
4	Subsystems 5.0, 6.0, 7.0, and 8.0 of the Model.....	81
D-1	Histogram, Third Year Plumbing Apprentices Total Score On All Test Items	157

CHAPTER 1

BACKGROUND AND STATEMENT OF THE PROBLEM

INTRODUCTION

The task of vocational educators is to develop the skills and knowledge of the nation's manpower. This development may take place at a number of educational levels from special classes for the atypical in the formal school to the technological level at a post-secondary institution, or the training of workers in a complex industrial concern for productive and supervisory duties.

One significant aspect of vocational education is apprenticeship training. Apprenticeship, as a method of manpower development, has a long and honourable history that has its origin in earliest tribal societies (Butts, 1955, 9). The system existed in societies in many parts of the world, and can be found wherever the skilled worker had a status (Phelps-Brown, 1962, 66). The significance of apprenticeship training in Alberta may be gauged by the large number of people it serves. As of March 31, 1970 there were 9,590 persons registered as apprentices in the Province of Alberta learning a number of different trades (Provincial Apprenticeship Board, 1970a).

Apprenticeship training is essentially carried out on the job. The apprentice learns his trade from the journeyman with whom he works. The length of the training period has been set to some extent by tradition and varies from country to country (International Labour Office, 1966, 56-61). In Alberta the period of apprenticeship varies from three to four years according to the trade (Provincial Apprenticeship-

ship Board, 1970b).

The tradesman of tradition, to show that he had well and truly learned his trade, made a masterpiece. The acceptance of the masterpiece by the guild showed that the training period was at an end. Then the young tradesman was accepted into the guild as a master craftsman (Butts, 1955, 157). In a number of countries emphasis is still placed upon the apprentice passing a test of his practical skill at the end of the apprenticeship period. Although examinations in related theory are sometimes set, the weight that these examinations carry is usually much less than the practical examination (International Labour Office, 1966, 110-129). The Alberta practice, however, appears to emphasize theoretical examinations by pencil and paper tests, rather than examinations of practical skill. This conclusion is drawn from Trade Training, Is Apprenticeship for You? (Provincial Apprenticeship Board, 1970b), which states,

When the period of apprenticeship has been served (four years in most trades) and all courses successfully completed, the apprentice writes the Journeyman examination, and if successful, he is certified as a qualified tradesman.

This introduction illustrates the inherent dual nature of apprenticeship: a method of preparation for entry into a craft as a skilled worker, and a method of education that has roots firmly established in the past. Furthermore, it appears that the philosophy and methods used to evaluate the skill and knowledge gained by the apprentice during his training period vary considerably from place to place.

APPRENTICESHIP IN ALBERTA

Apprenticeship in Alberta is a formal system administered

by staff of the Provincial Department of Labour under the direction of the Director of Apprenticeship (The Apprenticeship Act, 1969, s5). A person may become an apprentice only in certain designated trades (The Apprenticeship Act, 1969, s6). Currently 31 trades have been designated as trades that come under The Apprenticeship Act (Provincial Apprenticeship Board, 1970a). To become an apprentice a person must be employed in a firm where the trade is plied and must be at least 16 years of age with a minimum standard of education. The standard of education varies, in general, according to the trade area (Provincial Apprenticeship Board, 1970b).

The Apprenticeship system is formal, in that an application for apprenticeship is made by the worker to the Provincial Apprenticeship Board on a special form provided for the purpose that is also signed by his employer. Following approval of the application, a contract is drawn up that is signed by both worker and employer. The contract is then registered at the Provincial Apprenticeship Board (Provincial Apprenticeship Board, 1970b). In the event that the apprentice is a minor, the contract is to be signed by the father, mother, guardian, whoever has the legal authority. If there is no parent or guardian with that authority, then the contract may be signed by a judge having jurisdiction in the district in which the employer carries on his business (The Apprenticeship Act, s17).

The period of apprenticeship may be three or four years, depending upon the trade. During the apprenticeship there are periods of classroom training at a Provincial Institution that the apprentice must attend. These periods are from four to twelve weeks

in each year of the apprenticeship (Provincial Apprenticeship Board, 1970b). The Apprenticeship Act, however, indicates that no apprenticeship contract shall be for a period of less than twelve months exclusive of vacation period, and shall include not less than 2000 hours of training supplemented by not less than 144 hours of related classroom instruction (The Apprenticeship Act, s. 15).

A prospective apprentice must be employed "by an employer who is a Journeyman and who is prepared to enter into an apprenticeship agreement with him " (Provincial Apprenticeship Board, 1970b). The Apprenticeship Act (s.2) is not so specific with regard to employers, it may be a person, firm, or corporation. However, on-the-job training under supervision of a journeyman of the relevant trade is controlled by regulations issued under the authority of The Apprenticeship Act. The Regulations with Respect to the Trade of a Machinist (Alberta Regulation 260/67) specifies that for the trade of machinist an employer may employ one apprentice for every two journeymen employed (s. 3), but Regulations With Respect to the Trade of An Electrician (Alberta Regulations 196/69) specifies that an employer may employ one apprentice for each journeyman employed.

Apprenticeship in Alberta is a formal system of education that is given strength and legal status by an act of the Provincial Legislature and continued support by Provincial Regulations approved by the Lieutenant-Governor in Council.

MANPOWER DEVELOPMENT AND APPRENTICESHIP TRAINING

There are four considerations to apprenticeship training in

Alberta. These include the apprentice, the work situation in which each individual apprentice operates, the technical schools which are charged with the duty of imparting some skills and the related theory, and the Provincial Apprenticeship Board that has statutory obligations for the administration of apprenticeship training in the Province. Since the courses of study and the major examinations for the various trades are prepared by the Apprenticeship Board, see for example, Course Outline For Apprentice Electricians (Provincial Apprenticeship Board, 1969a), this has the effect of limiting the training to three major considerations: the apprentice, the work situation, and the Apprenticeship Board.

Apprentice tradesmen differ in abilities, as do all people. Indeed the development of aptitude test batteries was stimulated by the thought that the general intelligence tests measured, primarily, verbal comprehension. Contemporary thought recognizes a number of broad groups as factors of intelligence tests, although Guilford, in his model, proposed some 120 cells, Vernon, in his model, proposed two major group factors verbal-education, and practical-mechanical (Anastasi, 1961, 337-361). From this recognition of individual differences it is a short step to the recognition that a manpower development programme might be inconsiderate to emphasize particular abilities such as those manifest in the score given for a written examination, rather than the more general abilities that are needed when at work.

It is intuitively evident that there must be variations in the abilities of different employers in the Province to provide satisfactory on-the-job training for their apprentices, probably

wide variations. At this point, cognizance must also be given to the Provincial extremes of rural and urban situations. Furthermore, attention must be given to the motives of different employers. Some employers could have a commitment to train manpower for their own use and for the industry as a whole, but other employers might not be so committed.

The Apprenticeship Board administers the Apprenticeship Act and so plays an important part in the industrialization of the Province as a whole, and in the lives of the many individuals who earn a living, or are intending to earn a living, as skilled tradesmen. The life of the apprenticeship tradesman is affected by regulations of the Provincial Apprenticeship Board that apply to his rate of pay and the frequency of his pay increases, as well as to other less personal matters; however, it must not be construed that these regulations are of necessity unfair. The regulations require that an employer increase the pay of the apprentice as his ability is shown to increase. During the apprenticeship period, apprentices are paid a certain percentage of the prevailing journeyman rate of pay that varies according to the year of the apprenticeship and the trade. For example, automotive mechanic apprentices are paid 55, 65, 75 and 85 per cent of the prevailing journeyman rate (Alberta Regulation 387/65), and electrician apprentices are paid 45, 55, 65 and 75 per cent of the prevailing rate for a journeyman electrician according to which of the four periods of their apprenticeship they are recognized as serving. The apprentice is able to progress from one apprenticeship period to the next, or to journeyman status by passing an

examination prescribed by the Apprenticeship Board and obtaining a satisfactory report from his employer and the technical school. (See for example, Alberta Regulation 260/67, Regulations with Respect to the Trade of Machinist).

Apprenticeship in Alberta is linked to The Tradesmen's Qualification Act. This Act prohibits any person from engaging in any trade, designated under this Act, unless he is the holder of a certificate of proficiency issued in respect of the trade (The Tradesmen's Qualification Act, s. 2(b)). Furthermore, according to The Apprenticeship Act (s. 21 (2) (g)) certificates of qualification in a trade may be cancelled or suspended. In addition, the holder of a certificate of qualification may be required to re-appear for re-examination at any time at the discretion of the Apprenticeship Board (Alberta Regulation 260/67).

Examinations are an important part of the apprenticeship training scheme in Alberta. These examinations differ from the traditional practice that emphasizes the demonstration of practical skills that are learned from contact with skilled artisans by on-the-job training. Instead, concentration is on the theoretical aspect of the trade.

STATEMENT OF THE PROBLEM

There is a rapid rate of change of industrial techniques and an increasing flow of technological information with which, numerous complaints indicate, existing systems of apprenticeship do not keep pace. In fact major deficiencies may be listed: changing skills are given little recognition, often obsolete train-

ing syllabuses are used, training is often thought of as for a lifetime thus not giving recognition to changing skill requirements and the differing demands of various employers, there is lack of liaison with formal education, and poor quality training (Singer and Macdonald, 1970, 15).

PURPOSE OF THE STUDY

The purpose of this study was to develop a systems model for apprenticeship training.

This model is job-centred and takes advantage of the technique of job analysis to ensure that the apprentice is trained for the skills that are actually needed for his work. From this analysis of the job, training objectives will be developed. These objectives will then be used for the preparation of both on-job and off-job training courses, and are the basis for the evaluation of the apprentice. A quality control function is built into the model in order to monitor the training of the apprentice both by his employer, on-the-job, and by the training institution, off-the-job. This quality control function also provides for the validation of training by continually surveying the apprentices and their employers regarding the suitability of their training for the job that they actually do.

The use of a systems model is to provide for a continuous flow of information between different segments of the model. This information flow is necessary in both forward and backward directions. The use of feedback information is necessary in order that the system can adjust itself to changing demands.

NEED FOR THE STUDY

Insufficient studies on apprenticeship training have been carried out in North America, despite the fact the apprenticeship as an educational method is both widespread and common. The studies that have taken place, or are under way, in Canada incline towards the economic value of apprenticeship. However, there are other aspects that must be studied if only for the reason that these other aspects have not been studied previously.

Studies of practices in other areas of education have pointed to the fact that it is beneficial both to education, as a social science, and to society at large that both administrative machinery and evaluative instruments be subjected to scholarly scrutiny. This scrutiny and subsequent publication of the results is necessary in a democratic society in order that the democracy can be made visible to all, and, also, in order to increase the body of knowledge available to the social sciences.

Alberta has been industrialized at a rapid pace since it was touched by the industrial revolution, which, might be said, commenced at Leduc with the discovery of oil in 1947. To continue, or perhaps to increase this pace, more people in the Province must develop the skills and obtain the knowledge that is in keeping with the industrial age. Apprenticeship training is one way of doing this. This study will assist in the provision of information on the method of apprenticeship.

DELIMITATION OF THE STUDY

The study was confined to the development of a model that would provide for the continuous review of apprenticeship training, standards and evaluation, on the trades that are designated under The Apprenticeship Act of the Province of Alberta, or on similar trades.

One phase of the study was the application of the model to different aspects of apprenticeship training in Alberta. However, this application of the model was in static situations, because the model cannot be applied dynamically unless it is actually set into motion. At this time it is only a proposal. The application of the model was restricted to just a few trades, and just one level of each of these trades was selected in this study of the application of the model.

LIMITATIONS OF THE STUDY

The approach to training developed in this study is completely dependent upon the individuals who will be operating within the system. The study was made on the supposition that all communication channels were completely open, and that each individual or group responsible for a particular segment of the model completely understood their tasks, and carried them out. However, such an ideal situation is unlikely to be found in practice.

DEFINITION OF TERMS

Apprentice. An apprentice is a person, aged sixteen or

older, who enters into a contract with an employer in accordance with The Apprenticeship Act.

Designated Trade. A trade that comes under The Apprenticeship Act.

Journeyman. A person who is recognized as being a qualified tradesman by the granting to him of a certificate of qualification, certificate of apprenticeship, or a certificate of proficiency.

Provincial Apprenticeship Board. A five member group appointed by the Lieutenant-Governor-in-Council in accordance with The Apprenticeship Act. One member must represent organized labour, and one member industry. This Board is charged with the over-all responsibility for apprenticeship training in Alberta.

Trade Areas. Trades that are grouped together because of some common factor. Examples: construction trades with the construction, repair or maintenance of buildings; mechanical trades, concerned in some way with the repair of automotive vehicles; service trades, offer service to consumers as cook, baker, or T.V. repair.

CHAPTER 2

SEARCH OF THE LITERATURE

This search of the literature has been carried out in an endeavour to look for answers that might be pertinent in a study that attempts to rationalize or systematize apprenticeship training. As well as discussing models and systems in some depth, inquiries have been made into such matters as skill, and training both on and off the job. These matters have been looked into because they appear to be central to the study. Also it was thought necessary to make an enquiry into attitude as it pertained to the job and into aptitude testing, merit rating and examinations. All of these subjects are considerations in successful training schemes and should be brought to the notice of those interested in apprenticeship training.

A MODEL

The use of a model in the area of training is by no means unique. In an article entitled "Training Explained" Nadler writes,

In our field [of training] there is much that can be done with the descriptive model. As the name would indicate, it is an attempt to describe what needs to happen and in approximately what sequence (Nadler, 1971, 53).

The idea of model is complex. Thus it will be expanded further.

A model, according to Webster's International Dictionary is a set of plans for a building or structure, or it is anything that may serve as an example.

This simple idea of a model as a plan, agrees in essence with Nadler's view of a training model. A more sophisticated

explanation of a model is given by Downey (1963, 64-69) who discusses two types of models: theoretical and conceptual. A theoretical model, according to Downey, is in essence a mental image of some set of phenomena, that is, something not yet understood is thought of in terms of well-known relationships or symbols. Theoretical models may be used to predict outcomes in a field of study that is not fully understood by the outcomes of a model in a field of study that is well understood. A conceptual model is useful for systematizing information as a taxonomy is used, although frequently, taxonomies do not depict relationships among their elements. However, an effective conceptual model implies relationships between elements as well as the ordering of them. A conceptual model is a theoretical view of a real set of elements interacting with each other.

Thus Downey's conceptual model tends to agree with Nadler's model. The theoretical model that Downey discusses is well known in the physical sciences and has been used with excellent results to predict possibilities of occurrences with such theoretical objects as atoms and molecules. In fact, the basis of organic chemistry is that of structural theory which in general can only be completely understood by using a three dimensional model to depict a theoretical molecule (Morrison and Boyd, 1966,4). For example the discovery of the structure of the DNA molecule, by Crick and Watson, a major event in the biological sciences, was a matter of making a model. This discovery, made at the Department of Physics, Cambridge University, illustrates completely Downey's statement that theoretical models are used to predict outcomes in a field of study that is not completely understood. Actually the model embraced two fields of study, or

domains of knowledge (Downey, 1963, 96) physics and chemistry are in the physical domain, biology and genetics, which the DNA molecule explains, are in the biological domain.

As Restle remarks, ultimately the final answer to a substantive question must be obtained by a full scale experiment. However, before the full scale experiment is carried out, plans should be made, calculations carried out, and models constructed. These activities are as applicable to the social scientist as to the physical scientist (Restle, 1964, 111-113).

In fluid mechanics models are used to permit visual observations of theoretical possibilities. Quantitative data may be obtained from models, in this field, if similitude is obtained between the model and the proposed structure. Similitude refers to every part of the model being in the same ratio to the proposed structure as every other part, but with the added restriction that in the studies other concerns such as fluid flow and pressure must be kept at the same ratio between model and structure (Streeter, 1962, 166).

This same notion of similitude is used by Hall and Kerber in models for educational research under the term of isomorphism. These authors divide models into three general classes: iconic, analogue, and symbolic. An iconic model is used to convey a static or a dynamic condition at a particular time. The analogue model is effective in the representation of dynamic systems. Graphs and flow-charts are perhaps the simplest of analogue models. Symbolic models are used to propose an isomorphism between measurable properties in one area, perhaps learning theory, with mathematical

symbolism (Hill and Kerber, 1967, 14-19).

Some writers in the social sciences use other terms for what has been discussed as a model. Van Dalen uses paradigm as a synonym for model (Van Dalen, 1966, 65). However, Kerlinger, whilst agreeing that model and paradigm are synonymous believes that the word model has value connotations that paradigm does not (Kerlinger, 1964, 275). Paradigm meaning pattern or model is used in the study of linguistics (Francis, 1958, 187).

Hills, in a publication written to clarify matters on the subject of models and the more useful term, systems, refers to models as structural systems. Here the notion is of the order of relational properties of two or more elements. As an example of structural systems with different relations between the elements, consider the names "Roland", "Rohald" and "Arnold" these structural systems contain exactly the same elements but the relationships between the elements are different in each case (Hills, 1967, 6).

Hills also comments upon process systems and functional systems. The characteristic processes of social systems are the many forms of communication. Communication in the process system is feedback: both positive and negative, involving various kinds of communication media. The system is maintained in equilibrium by this feedback (Hills, 1967, 6).

The notion of equilibrium is central to systems theory. It may be static or dynamic. Static equilibrium is that quality of a system which when disturbed by some stimulus, tends to react towards its original state. On the other hand, the dynamic equilibrium of a system responds to stimulus by taking a different position or by

some change in the goals of the system (Lonsdale, 1964, 121-122).

Equilibrium in systems theory is indicative of the multidisciplinary usefulness of models and systems. Equilibrium is a necessary control feature of any living organism; equilibrium or homeostasis, in a living organism, acts to correct any disturbance within the organism (Guyton, 1971, 3). The disturbance could be a rise in body temperature, and so perspiration would be the corrective action (Hilgard and Atkinson, 1967, 41).

Equilibrium in any living organism is dependent upon feedback (Hilgard and Atkinson, 1967, 173). According to Griffiths, feedback is the process of returning the output information of a system to the system input and in so doing affecting subsequent output from the system (Griffith, 1964, 117). If a system is to be useful, it adapts to change in its environment. In short, systems learn. Using this idea, Lonsdale writes, that feedback is the process by which a system learns (Lonsdale, 1964, 173).

System theory is useful for the examination of social organizations; it has been used to investigate and predict results from changes in organizations. The theory of systems treats of both closed and open systems. A closed system is not in communication with its environment, whilst an open system acts upon and reacts to its environment (Griffiths, 1964, 116).

As Getzels points out, all social systems have functions that tend, over time, to become routinized, or institutionalized. These social systems, or institutions, are purposive in that they possess institutional goals. They are also organized and the people within them assume roles and are responsible for certain

institutional tasks (Getzels et al , 1968, 57-58). Such an organized social system together with the roles that are implicit with the system is termed by Hills as a functional system (Hills, 1967, 10). The model that was the subject of this study is in accord with Hills' process system in that it is dependent upon both forward and backward communication, or feedback, to maintain it in a state of equilibrium. It must also be recognized as an open system. One that acts upon and reacts to the supra-social-system. However, since this process system is also a social system with people in the system behaving according to the roles of the system at times, it must be regarded as a functional system. A functional system recognizes that change in one variable, or function, in the system results in change to other variables, or functions in the system (Hills, 1967, 10).

SYSTEM RESEARCH

In a systems context, research may be regarded as having two dimensions: monitoring and improvement. Monitoring is the comparison of actual system input or output, with input or output criteria. It is the endeavour to maintain the operating integrity of the system as it was designed. Subfunctions of the monitoring function are: quality control, data storage, interpretation of data and communication channels. Monitoring has the function of maintaining the status quo of the system. Improvements in systems operations are made by analysing errors and wastage. The more accurately the variables that constitute errors and waste are identified, the greater improvement to the efficiency and effectivity of the system.

It is an axiom that any system left to run by itself will be progressively degraded. Systems research will resist and reverse the trend of systems toward death. However without effective channels for the processing and embodiment of research information the function will be impotent (Miller, 1961, 369).

It should not be necessary to remark that all who are in any way connected with education should strive to increase their knowledge of the total process, and to improve their performance in each part of the whole. Change should not be made without reason. Experiments should be made and ideas tested. Kerlinger remarked to this end, that if the researcher believes that something is so, the belief must be put to a test (Kerlinger, 1964, 13). The implication is that mere belief is insufficient. In a similar way Whitehead objected to the use of common sense as a basis for thought or new ideas. Whitehead remarked, about the application of common sense to problem solving, "Its sole criterion for judgement is that the new idea shall look like the old ones" (Whitehead, 1958, 157). Change based merely on common sense, Whitehead might say, is not progressive.

SKILLED BEHAVIOR

In order to discuss the preparation of skilled tradesmen it appeared necessary to have some understanding of just what the concept of skill encompasses. This is important prior to the examination of any job of work that will necessitate categorizing the job, or task, as skilled or unskilled.

D.H. Holding appeared to look at skilled performance as an industrial engineer would regard it, merely as a pattern of movements.

This position was obtained when he wrote that, the completion of a skilled task requires information on what is to be done, sensory information resulting from the task, and information about the results of actions. These three kinds of information make a complete loop composed of input, output and feedback. Feedback may be internal or external. Reliance on external feedback is typical of the beginner at a task, the smooth rhythmic movement of the skilled operator is indicative of internal feedback through the kinesthetic loop. The skilled operator disregards much of the information received by his senses, experience has taught him to note only the important and exceptional cues (Holding, 1965, 13-14).

Seymour however, appeared to examine skilled behavior with a little more depth than does Holding, and wrote that all industrial tasks have both knowledge and skill sectors. The internalization of the knowledge sector permits the psycho-motor activities of the skill sector to proceed without interruption, and so reduces the difficulty of the task. The learning of a task that requires an input of symbolic information together with non-symbolic is well known to be difficult. Another difficulty occurs when the rhythm of a psycho-motor activity must be interrupted for an input of symbolic information as occurs in many wiring jobs. Other learning difficulties occur when the work is 'fine', that is when the discrimination necessary for the task is close to the threshold for the sense in use. This sense may be visual, tactual, kinaesthetic, or auditory (Seymour, 1966, 85-86).

Probably a necessary cautionary note was made by Fleishman resulting from his studies with the armed forces of the United States

when he pointed out that there is a difference between ability and skill. Abilities are basic traits learned possibly, but nevertheless completely part of an individual. On the other hand, skills are task oriented. In flying an aircraft, trouble shooting an electrical circuit or some piece of equipment, or operating a machine tool of some type, a specific skill is being used. The learning of these skills is the learning of a particular sequence of responses. A trait such as space visualization must be regarded as more basic than a skill when it can be shown to be related to such different tasks as aircraft navigation and dentistry (Fleishman, 1962, 138-139).

From a review of his own experiments and those of other workers in the area of skilled performance, Fitts concluded that, tasks are changing rapidly as a result of changes in technology. For example the importance of primary motor skills is decreasing whilst the importance of perceptual skills is increasing. The skills that seem to be of increasing importance are those that require the individual to receive and put into short-term memory quite a number of separate stimuli. This stored information must be collected in various ways, compared with other stored information and then decisions made. It is apparent that a taxonomy is required for skilled tasks. Since skilled work emphasizes the dynamicism of input, output and feedback the taxonomy should recognize processes and activities rather than static measures (Fitts, 1962, 178). The taxonomy that Fitts proposes can perhaps be categorized as follows:

- I Degree of gross body movement
- II Extent of external pacing of the activity

A. Stimulus and response sequences

1. coherence
2. continuity
3. frequency
4. complexity

B. Stimulus-response coding and code transformations

1. visual, auditory, tactual, etc. inputs
 - (a) size, colour, pitch, etc. of inputs
2. vocal or manual output in many forms
 - (a) force, amplitude, or other characteristics

C. Nature and amount of input and external feedback

1. amount of input
 - (a) quality of input
2. amount of feedback
 - (a) quality of feedback

D. Nature of internal feedback (very difficult to measure and control)

E. Dynamics of physical system [here consider where and how to brake a motor vehicle in order to bring it to a halt at a predetermined point. Similar concerns occur in the operation of machine tools.]

F. Overall task complexity

1. Number of separate sources of input or feedback information
2. The number of external systems with separate dynamics
3. The number of separate actions to be taken serially as well as concurrently (Fitts, 1962, 179-183).

Maier points out, that to a psychologist an act of skill is a pattern of movements that has been learned. This act is quite

independent of knowledge. Hence it is important to differentiate between a skillful worker, who actually might be unskilled in an industrial sense, and the skilled tradesman of industry (Maier, 1965, 378).

JOB ANALYSIS

Before training of any type can take place there must be information as to what should be taught. In industrial training this information should be derived from an analysis of the particular job for which a person is being trained (Tiffin & McCormick, 1952, 58).

It was not the purpose here to discuss how a job should be analyzed, there is a great deal of information on the various methods of job analysis (Roff and Watson, 1961, 8). The purpose was to point out that for the design of an adequate training course a job analysis must be a first requirement. To this end, Shartle complained that,

All too often psychologists and personnel workers carry out procedures requiring job information without having on hand the accurate and thorough information necessary (Shartle, 1950, 135).

Similar to Shartles' complaint was that of Lynton and Pareek who wrote that,

Most job analyses now in use are inadequate even as descriptions of current activities. They specify a series of required qualifications in subject-matter knowledge and technical skill, that is all. To serve as the basis for training designs, job analyses have to go beyond these simple lists and describe how a job has to be performed, for example, under what physical conditions and time pressures and with what access to colleagues, superiors and additional resources. In short, the job analyses have to be operational (Lynton & Pareek, 1967, 85).

Lynton and Pareek were writing about training in the United States

as representative of highly industrialized nations and of India as representative of developing nations. They asked the question, "whether all this training activity the world over, or even the greater part of it, can be justified by its results." They answered their question, "no, with honorable exceptions" (Lynton and Pareek, 1967, vii). The thesis of their writings was that the training of all descriptions must be improved, hence their complaint of job analyses.

An interesting discussion of job analysis was given by Neff who was concerned with individual differences in the work place. He noted that, "the job analyst has often had a tendency to overlook the other side of the equation - the worker himself" (Neff, 1969, 176). As Neff pointed out, job analysis derives from the early time and motion studies of Taylor and Gilbreth (Neff, 1968, 20).

Miller, in his "Analysis and Specification of Behavior for Training", had both sides of Neff's equation in mind. He wrote that, although it is necessary to specify the physical performance requirements of a job, this is not sufficient for good training design. A psychological description, also, is at least desirable if not essential (Miller, 1962, 31).

This point of Miller is in agreement with findings in Britain that a craftsman's job is not an amalgam of a series of unskilled jobs, but that it has a psychological content, which, although difficult to measure, must be taken into account (Engineering Industry Training Board, 1971).

This section may be summarized by saying that training is wasted if the training is not validated by a job analysis, and further,

that job analysis should not just recount the visible movements of the worker but should endeavour to note the psychological dimensions of the job.

ATTITUDE

Although the attitude of an apprentice to various aspects of the work-situation as viewed by significant others, such as employers, supervisors, journeymen, instructors, other apprentices, will undoubtedly affect his progress as he makes his way through an apprenticeship programme, it is beyond the scope of this particular study to examine the question in any detail. It must suffice to discuss a few significant facets of the question.

Most of us judge people by their attitudes, but just what attitudes are and how they are formed is a complex area of study. One definition of attitude is that an attitude is "a predisposition to experience, to be motivated with respect to and to respond to a class of objects in a certain way" (Smith, Bruner and White, 1956, 7).

The study of attitudes may be approached by a number of paths: culture - personality, cognitive, psychoanalysis, among others (Smith, Bruner and White, 1956; Rokeach, 1960).

An important dimension of attitude for any educational system is that of the attitude of an individual toward taking tests. One aspect of test taking, the amount of time spent taking tests was summarized by the statement,

If a respondent believes that standardized tests of ability are accurate, or that his performance on such tests accurately reflects his real intelligence, he will be more likely to hold positive rather than negative attitudes towards taking these tests (Brim et al, 1969, 97).

A theory of attitudes applicable to the work situation was developed by Breer and Locke of the School of Industrial and Labour Relations, Cornell University. This theory might be summarized by saying that,

In working at a certain task, occupation, or trade an individual develops certain beliefs, values and preferences specific to the task itself which over time are generalized to other areas of life (Breer & Locke, 1965, 10).

The theory was supported by a number of laboratory experiments (Breer & Locke, 1965, 256).

The implication of the study was that in a stable society most people will be able to find jobs suitable to their attitudes. However, in a mobile society resulting from technological change there will be a number of individuals who are required to take up occupations which require attitudes that are not congruent with their own. That is there will be a lack of symmetry between the attitudes brought to a work situation and the reinforcing properties of the situation itself (Breer and Locke, 1965, 20).

Ridgeway, in Industrial Training International, wrote,

From the research evidence available it would appear that effective training, that which produces the required attitudes, knowledge, skills and behavior in the trainee, will only be achieved through either matching the trainees' motivation, intelligence, personality and other characteristics to the course or structuring the course to "fit" the trainees' characteristics.

The assumptions that trainees with the same training needs who follow the same course of training will acquire the same degree of attitude, skill, knowledge or behavior would appear not to be valid (Ridgeway, 1971, 175).

The proposal that Ridgeway made points to homogeneous grouping in many dimensions or to make allowances for individual differences to a degree that is probably uncommon in apprenticeship

training. There are probably a number of practical reasons why the first will be difficult to carry out except on a one-to-one basis between apprentice and the on-job or off-job instructor. The second one is an individual progress plan. Using what is known about educational technology today for off-job instruction, this proposal is quite possible. With a sympathetic supervisor and work group much is possible; however, the fact that there are limits to dependence and independence is crucial in most work situations. On this matter Neff wrote,

It is not too much to say that failures in job performance and subsequent dismissals may more often be due to insufficiencies on this dimension than because of sheer lack of some required skill or aptitude (Neff, 1968, 125).

Neff also pointed out that the work-situation also demands a balance between the personal and the impersonal and the necessary flexibility to adjust in a moment. Thus extremes of attitude or other affective behavior might be tolerated in the off-job training situation but not in the on-job situation.

TRAINING

Training appears to mean different things to different people, and since apprenticeship is often referred to as training in the literature, (Provincial Apprenticeship Board, 1970b), just what is regarded as training must be examined closely.

Douglas Seymour, has discussed training from two view points: the subjective and the objective. On the subjective level, training is the acquisition of the skill and knowledge necessary for the effective performance of a task. Objectively, it is the teaching of the skill

and knowledge necessary for the task to be mastered. From semi-skilled to skilled work, the required "skill and knowledge have to be acquired on a task by task basis" (Seymour, 1966, 161).

D. H. Holding has a similar view. Training has quite specific objectives and the results should be measurable. On the other hand, it may not be possible to define the objectives of education, and the educational procedures, but possibly, because of the breadth of education, it may not be demonstrably efficient (Holding, 1969, 1).

This separation of training and education whilst common, is not general. According to Wolfle, training is the applied aspect of learning, and investigations of teaching both in industry and the schools are classified under training (Wolfle, 1951, 1267).

The similarities of training and education were noted by Glazer, when he wrote, "The process of training and education is concerned with techniques and procedures of guiding and modifying human behavior" (Glazer, 1962, 1).

Consonant with Wolfle's view that training is the applied aspect of learning but perhaps wider in scope was the view of Miller who has written. "Training is applied behavioral science just as engineering is the application of the physical sciences" (Miller, 1962, 34).

Apparently a new thought has derived from training experiments in Britain. That is for craftsmen, training should be guided discovery in order to develop the planning skills and problem solving strategies and decision methods to form the intellectual component of skilled behavior (Engineering Industry Training Board, 1971, 24-26).

However, if the discovery method is a teaching technique then the British conclusions agreed with Glazer's thesis, and also that of Porter who was concerned with "systems training" in the United States Air Force, who wrote that controlled discovery as a method of training can be grasped, effectively, only by experiencing it (Porter, 1964, 67).

A study, that was sponsored by the European Economic Community, O.E.C.D., involved using the discovery method for training experiments in Austria, Sweden, the United Kingdom, and the United States. The conclusion of this international experiment is that the discovery method of training is superior to the traditional or expository method. The trades involved were such extremes as stonemasonry and data processing. Some results of training using discovery compared with traditional training methods were significant at the one percent level. An important facet of training by the discovery method is that there was increased motivation, especially by older and by minority group trainees (Belbin, 1969, 24).

That the discovery method is a general technique is held by Jerome Bruner, who also implied that it is as useful for training as it is for education regardless of what dichotomy between the two is perceived. In his, The Process of Education, he wrote to the effect that, discovery, both as a teaching method and as a mode of learning, has been urged by a number of workers in the academic disciplines. However, the method is not confined to the formal subjects (Bruner, 1963, 20-21).

The view of Holding (1969) that training must have objectives

with results that are measurable is entirely in agreement with Mager. Mager's notion was that any training program must have a statement regarding the objectives of the program. These objectives must denote measurable attributes that are observable in the program's graduates; otherwise it is impossible to determine the success of the training program (Mager, 1962, 3).

Different view on just what is training might derive from the application of training principles to tasks with different dimensions of skill. Britain's Engineering Industry Training Board noted that,

manipulative skills of craftsmen are less central in achieving experienced worker standard than are knowledge and the ability to apply theory constructively and flexibly (Engineering Industry Training Board, 1971, 26).

On this point Maier wrote that it is the unskilled worker who does most of the manipulative work. The tradesman, or skilled worker, requires both manipulative skills and knowledge. These two facets to skilled work are quite independent of each other. Thus training operatives in manipulative skills would be approached much differently than in training tradesmen in a craft that has a high cognitive content. Training for the cognitive area, the heuristic skills of a job is recognized by Miller, and he remarked that training for decision making is "the point where education and training merge" (Miller, 1962, 55).

According to Troyer, teaching at all levels necessitates the setting of performance objectives in behavioral terms (Troyer, 1971, 44). This is contrary to Holding (1969) who considered that objectives are applicable to training but not to education.

From this section it was gathered that learning theory is as applicable to training as it is to education, if indeed there is a difference between these two activities. Also, the skills of a tradesman might vary from the purely manipulative to the purely heuristic skills and with any mixture of these two components. Furthermore, to train as to educate requires the setting of objectives in behavioral terms in order that measurement of the effectivity of training can take place.

ON-THE-JOB TRAINING

On-the-job training is by no means confined to learning a trade by means of apprenticeship. The system is well established in all areas of the work-a-day world and it would be trivial to argue either for or against the system. Frank Metcalfe, Director of Britain's Engineering Industry Training Board, wrote that development of skill and knowledge has to take place in the workshop since the purpose of training is to enable the craftsman to practice his range of skills efficiently under the pressures of cost and time (Metcalfe, 1970, 30). We are all well aware that on-the-job training is used in the professions under various terms: medical doctors and school teachers intern; lawyers and chartered accountants article; engineers on completion of their academic work operate for a period as an engineer-in-training or, in some places, as an apprentice.

Although it is trivial to discuss the need for on-the-job training, the quality of on-the-job training is a matter of concern. To develop the breadth of knowledge and skills necessary for craftsmen in an industrial nation, on-the-job training must be rich.

The United States Navy, a large employer of tradesmen, has a training administrator at each of its facilities. It is part of the training administrator's task to ensure that each apprentice is rotated around the different shops in order that he may gain experience on different work assignments. Furthermore, this movement from task to task to give breadth to his work experience must take place regardless of the urgencies of productive work in any particular work area (U.S. Navy, 1967, 17). The concern of the United States Navy, that on-the-job training has breadth rather than narrow specialization, can be gauged from the Navy Civilian Personnel Instructions (NCPI 410), "A well organized, effectively co-ordinated, work experience and related information is necessary to accomplish the established objectives of apprenticeship training" (U.S. Navy, no date, 77).

Air Canada places the responsibility for training of its learner category of tradesmen, which is equivalent to apprentice, squarely on the shoulders of its line supervisors. The Supervisor's Manual read:

Because the efficiency of an individual's work pattern is developed almost entirely by the environment within his particular group, it follows that any lasting improvement in his work methods must come from action within that group. Therefore, training must primarily be considered a function of line supervision.

Training and good supervision go hand in hand - neither one is possible without the other. The quality and amount of training which a supervisor administers is one measure of his supervisory ability (Air Canada, no date, 2.1.1, 1).

The Supervisor's Manual of Air Canada was the source of a very useful definition for the training that is under consideration in this

section. This definition read:

On-the-job training may be considered as training which is given at the place of work and involves instruction on specific procedures by one who already knows the correct procedure. It may be given to a group or individually, by doing the job with the trainees looking on or assisting (Air Canada, no date, 2.1.1, 3).

The concern of Air Canada for tradesmen with a well-rounded background that derives from broad-based training was obtained from their Technical Training Policy which read:

As a part of on-the-job training, the rotation of individuals on a planned periodic basis from one phase of work to another plays a very important function. A properly planned Rotation Training Program has five distinct advantages:

1. It will permit development of a balanced work force.
 2. It will provide qualified replacements in the event of sickness, transfers, promotions, vacations, etc.
 3. For those planning to write Company examinations, it will provide the practical experience required.
 4. Applied to Learner and Junior Mechanic classifications, it ensures the full rounding out of practical experience to complement the classroom instruction being given throughout the course of training.
 5. It will tend to improve morale of the working force through increased job interest.
- (Air Canada, no date, 2.1.1, 4)

Similar concern that apprentices are given on-the-job training to provide a great deal of breadth to their training was shown by such organizations as The Chrysler Corporation (Main, 1970), Giddings and Lewis Machine Tool Company (Braun, 1970), Cincinnati Milacron (formerly The Cincinnati Milling Machine Company) (Cincinnati Milacron, no date).

The examples given have been of large business concerns in North America. The concern for adequate breadth in training also occurs in Europe. In a study of apprenticeship in Europe, the International Labour Office reported that,

The pattern of training that is evolving is therefore one of an initial period of basic training given outside production and lasting between 3 and 24 months, followed by planned work experiments ... to initiate the apprentice into the rhythm and pressures of production. During the latter period the apprentices may be assigned successively to several departments in the undertaking so as to gain as wide experience as possible of his own trade as well as some knowledge of related trades (International Labour Office, 1966, 97).

Small European firms, that have a narrow specialization, pool their resources to obtain the necessary breadth of training. Although the apprentice is under contract to one firm he is sent successively to different plants according to an agreed plan to gain the skills and experience that he cannot obtain at his present firm (International Labour Office, 1966, 98).

For certain trades in Denmark, an employer must demonstrate that his workshop facilities, tools and equipment are sufficient and adequate, and that he has sufficient work of varied types as well as the skilled craftsmen necessary for the instruction of apprentices (International Labour Office, 1966, 133). In fact, most countries have regulations that require employers to have adequate facilities and competent journeymen tradesmen before they are permitted to take apprentices into the firm (International Labour Office, 1966, 134).

This section has provided the background to show that a competent tradesman with in-depth knowledge of his trade should have a broad experience during the formative years of his apprenticeship training. This broad experience is provided by larger organizations by rotating their apprentices to different work assignments in their own organizations. Employers in specialist types of work undertake co-operative agreement with other employers in order that their

apprentices may gain wide experience. Other employers must satisfy the relevant authorities that their facilities, work and staff are adequate for the training of apprentices.

APTITUDE TESTING

In Canada the notion of aptitude testing to suggest an individual's place in the work of work is not widely accepted. However, there are indications that it is necessary.

Johnson, in a study of apprenticeship in New Brunswick that took place in 1966, suggested that,

... one solution to the problem of the high drop-out rate is the administration of a battery of aptitude and interest tests to all apprenticeship applicants prior to the commencement of training (Johnson, 1967, 21).

This same suggestion was reported by Hammer, almost twenty years previously, in his dissertation, when he quoted members of management as saying, "The closer we screen the prospective apprentices the sooner we will have quality mechanics" (Hammer, 1950, 23).

The Canadian Forces have developed aptitude tests. Combinations of these tests and different test weightings are used to predict the suitability of a recruit for training in four occupational areas: mechanics, technical (scientific), communications (electronics), clerical. The validity of the aptitude tests was assessed in terms of manpower wastage at different score levels. The results of these aptitude tests show that they are effective predictors of trade training success (McInnis, 1968).

From a survey of a few North American industrial organizations, it was apparent that employment testing, screening tests, or aptitude

tests (these might all be different terms for the same, or similar tests) are reasonably common, at least among the larger undertakings.

The Giddings and Lewis Machine Tool Company, Wisconsin, stated:

Each applicant for our apprenticeship program must take two qualifying tests and obtain a score above the limits established by the Company and previous tests. His next step is to take the general aptitude testing at the Wisconsin State Employment Service. Finally he is tested by our local technical institute and this will determine the potential success the applicant will have in one of the apprentice fields (Braun, 1971).

The Chrysler Corporation had a similar testing procedure for apprenticeship applicants. The applicants must:

Be a high school graduate or equivalent (successful completion of General Education Development Test)

Satisfactorily pass the appropriate Chrysler personnel screening test and the uniform apprenticeship application and selection procedure tests (Main, 1971).

Applicants for the training programmes of Cincinnati Milacron, must provide a high school transcript and take appropriate tests (Personnel Development Centre, no date, 1).

The Lockheed - California Company, a Division of Lockheed Aircraft Corporation, established an apprenticeship program in 1939 jointly with the local lodge of the International Association of Machinists and Aerospace Workers. Applicants for positions there must "have the aptitude and potential ability for the trade as determined by qualifying tests" (Lockheed Apprenticeship Program, 1969).

In Canada, those who aspired to be apprentices at the shops of C.P. Rail require grade 10 mathematics or be successful on a Company mathematics test and must pass an Aptitude Test (Hayward,

1971).

Air Canada, though, required only that those hired in the mechanical trade categories will have Grade XI or equivalent. This does not, however, imply that apprentices are engaged with no thought of their abilities or aptitudes for work, "since future permanent employees are normally selected from temporary employees" (Air Canada, no date, 1.1.1, 1). Thus it was obvious that the intent of Air Canada was to examine the people who want to learn one of the aircraft trades whilst they were temporary workers and presumably, not subject to union restrictions regarding subsequent discharge. What is regarded as "temporary" is not stated; however, the implication was that it is sufficient for a satisfactory judgement of the potential learner's aptitude and ability for the trade to be made.

It was not just the larger organizations that used tests for the selection of apprentices. R. Angus (Alberta) Limited, an employer of about 650 different workers and a Caterpillar Tractor dealer, required for apprentices a minimum of Grade X education and to be physically fit (R. Angus, no date). The would-be apprentices were given the Psychological Corporation, Mechanical Comprehension Test Form CC and the Wonderlic Personnel Test. The applicants had also to provide two references, a transcript of marks from Grade IX up, and satisfy an interview panel of three members (Rozenhart, 1971).

According to Ginsberg, most young workers begin with only a general idea of the kind of job they are seeking. Discussing experience in New York, he wrote that a young person of minimum literacy and personable can usually obtain a job. Whether this job

or the next one would lead to establishment in a career is another matter. The early years in the working world are a period of many job changes, and depending upon the outcome, these years can be looked upon either as a period of useful exploration, or as one of aimless floundering (Ginsberg, 1969, 141-142).

The implication of immaturity of young people who are trying to establish themselves in the world of work in Ginsberg's writings was not in agreement with the findings of Johnson's New Brunswick studies of drop-outs from apprenticeship programmes. The hypothesis that those who 'completed' an apprenticeship were more mature than those who 'cancelled' their contract was not supported in the study (Johnson, 1968, 15). Of course, the conditions in New York were without doubt much different than those of New Brunswick. That the drop-out problem in apprenticeship is significant may be gauged from Manitoba statistics. For the year ending October 31, 1969, there were 304 cancellations of apprenticeship contracts compared with 748 new registrations (Department of Labour, 1969, 35). These data appeared to support Ginsberg's thesis of early years in working world being a period of many job changes.

The correlation between intelligence and success in training has been noted (Super and Crites, 1949, 87 - 89). However Super wrote:

Intelligence, surprisingly, has little to do with getting an entry job When employers consider inexperienced workers they are more influenced by evidences of maturity, that is, by size and manner, than by intelligence (Super 1957, 109).

The importance of good methods of personnel selection has also

been noted by Ginsberg. He has written, "Improved selection and improved training and utilization of personnel are the keystones to a more efficient manpower program" (Ginsberg, 1959, 137).

This section has noted the widespread use of aptitude testing in personnel selection for apprenticeship both in large organizations and in small. It has also noted that at least one of these organizations uses government facilities for aptitude testing of apprentices.

MERIT RATING OF APPRENTICES

Since apprenticeship involves on-the-job training, the apprentice's performance at his work situation must, almost by definition, be used to estimate the skills and abilities he has learned, his usefulness to his employer, and to predict his success in the trade.

According to Otis and Leukart,

The available evidence that workers differ in their ability to perform jobs and that these differences are reflected in their individual worth to the company is over-whelming. Workers show their value to a company in other ways than production. Such factors are receptiveness of supervision, attendance, quality of work, ability to get along with others, and length of time on the job are examples (Otis and Leukart, 1956, 443).

On the subject of merit rating Tiffin wrote,

Merit rating is simply a systematic way for a supervisor to record his judgement about the job-performance of an employee. It is new only in the sense that it involves a record of judgement made. Unrecorded ratings of employees by supervisors have been made ever since one man worked for another. And these unrecorded judgements have often played an important part in the future of the man rated (Tiffin, 1962, 175).

Ratings are judgements. There is no exact boundary between tests and ratings, rather a zone where they coincide; however if a

trait can be tested, it should not be rated. Ratings are inherently subjective, and they merely portray patterns of inter-personal perceptions at a certain point in time. Ratings do not measure merit, they merely indicate patterns. A number of ratings will indicate a trend, and not, of necessity, always an accurate indication (Best, 1962, 181).

Best wrote:

But if ratings are such ambiguous and awkward instruments; why use them at all? Primarily because we have no choice! Rating is an inescapable and indispensable feature of personnel administration. If formal methods are not provided, or if they are inappropriate, ratings will be made informally (Best, 1962, 181).

A study by Seashore and others concluded that inter-correlations between five job performance variables, that were suitable for the study, were small, and that the size and direction of the correlations were more variable than could be expected on the basis of measurement and sampling errors. The data were interpreted as contradicting the validity of a score for overall job performance as an unidimensional construct, and as a basis of the practice of adding together the scores for each of the variables into a single job performance measure. It was suggested that the measurement of job performance will remain at a primitive and empirical level until some complex theory of job performance is created (Seashore, et al, 1962, 216). However, the employee probably needs some indication of what opinion the supervisor has of him. We all require feedback of some form. Merit ratings should be used for employee guidance. If a worker is not performing to the expectations of his supervisor, the rating should be discussed with him for the mutual benefit of all

concerned (Patton and Littlefield, 1957, 298).

The Canadian Forces used On-Job Training Standards against which each trade trainee is assessed by his supervisor. These job standards describe as clearly as possible the limits of acceptable performance for each task (Canadian Forces Headquarters, 1970, 1-1). Furthermore, the implication of on-job training and job standards was that all levels of supervision are required to,

treat all trainees as individuals, to tailor training expressly for each trainee, to monitor each trainee's progress, and eventually to know each trainee well enough to certify his competence in the performance of his duties (Canadian Forces Headquarters, 1970, 1-4).

The United States Navy evaluated the performance of each of its civilian apprentices. It is the duty of the apprentices' supervisors and instructors to keep him informed of his progress and provide him with the necessary advice and assistance (United States Navy, C.S. 118, 83).

Although a number of methods of merit rating are available for the purpose of explaining ratings, the graphic method using a scale was preferred, and because of the notion that fine discriminations as indicated by a continuous scale are impractical, discontinuous scales are rapidly coming into use. The discontinuous scale recognizes the human limitations of the rater. Furthermore, it is easily understood by the parties most involved, the employee and his supervisor (Patton and Littlefield, 1957, 306).

Colquhoun, a student of Elizabeth Hagen and R.L. Thorndike at Columbia, used a discontinuous scale of five points to measure ten areas in a ward performance rating scale of graduate nurses in Ontario (Colquhoun, 1967, 59-63).

The recorded or unrecorded rating of apprentices is a fact of industrial life. Since in the common apprenticeship agreement the apprentice is the most vulnerable partner (International Labour Office, 1966, 105), it is only reasonable that the supervisor's judgement of the apprentice's performance on the job should be open to scrutiny. This scrutiny should properly be a counselling interview between the apprentice and his supervisor with an opportunity for a representative of the statutory body responsible for apprenticeship training to be present when necessary.

Performance rating is considered to be important to the economic life of a nation. This was Hutchinson's theme when he wrote,

Higher standards in the measurement of a fair days work have ... reflected themselves in growth of national income by gaining greater output from given amounts of human resources (Hutchinson, 1963, 8).

Hutchinson went on to say,

The determination of a fair day's work is no simple task. It involves both definition and measurement to the concept, and neither of these activities is easy to perform ..., it would seem that the measurement of a fair day's work can best be done when the worker and the company understand each others' interest and goals (Hutchinson, 1963, 61).

The evaluation of the performance of professional engineers was suggested, by the National Society for Professional Engineers, to be done in an entirely similar way to that which others have proposed that workers in more ordinary pursuits should be evaluated. On this matter was written, "Evaluation of engineers is a matter of human judgement and should not be disguised as anything else" (The Professional Engineers in Industry, 1965, 7).

The report went on to say,

...it is essential that the immediate supervisor conduct an interview with each engineer, reviewing in detail the results of the performance evaluation. This should include frank discussions of the individual's strong points and accomplishments, pointing out areas in need of improvement. This is the only real means the engineer has of knowing what he must do if he is to progress within the organization ...

The numerical score obtained by evaluating the engineer on some eleven traits each having a nine point scale and different weights for each trait may be used for pay increases and for promotion purposes (The Professional Engineer in Industry, 1965, 12).

The evidence was overwhelming that judgements are used in industry to rate workers even including the professionals. And whilst these ratings are not based upon a sound basis of theory, they must be used for employee growth and development until some sound theory of job performance is developed.

EXAMINATIONS

According to Smith, the standard of performance that a student should meet to indicate successful completion of a training course should be the final component of the objectives for the training course stated in behavioral terms. There are usually two kinds of performance standards - accuracy and speed. Under accuracy, there should be:

- (a) What percentage of problems must the student work correctly? Here problem is not defined, hence it could be construed to be either in the practical domain or in the theoretical domain.
- (b) What percentage of correct answers to questions

must he give? The questions must be within the range that will be stated as the condition under which the behavior will be observed.

(c) Within what tolerances must he work?

The second standard is that of the speed with which the task must be performed. An example of a course objective, that includes the three components of a behavioral objective: performance, conditions, standards and then by utilizing both of the standards, accuracy and speed, is the statement,

The student will identify any malfunctioning component in a standard superheterodyne radio receiver. He will use a screwdriver, multimeter, and schematic drawings: over 80% of the malfunctions must be correctly identified within 15 minutes (Smith, 1964, 65).

The Canadian Armed Forces have been much influenced in the development of their training system by Robert F. Mager's writings on developing instructional objectives. Furthermore,

Concerning the measurements of results, we are primarily concerned with practical performance. In performance tests, objectivity is obtained by stipulating the test conditions of time and accuracy (Mayhood, 1971).

The influence of behavioral objectives on the Canadian Forces Training system can also be derived from the publication, Canadian Forces Training System Manual, where it is written,

1. The most desirable means of measuring the effectiveness of training is a performance check. This is a standardized test that requires the trainee to demonstrate that he has mastered each one of the objectives of the course. The problem is to devise tests that will adequately measure the effectiveness of a given program.
2. Performance checks in training situations may be used to monitor the quality of training and to diagnose instructional difficulties.
3. An important purpose of performance checks in training

programs is to monitor the ability of the trainee to accomplish the objective for which he has been trained. If all, or nearly all, trainees can achieve the objectives, the training program is satisfactory, or perhaps could even be shortened to provide more time in other areas. If too many trainees fail to achieve the objectives, training is ineffective and requires investigation to determine the reason for the failure rate.

4. To monitor the effectiveness of training, performance checks should have the following characteristics.
 - (a) They should directly reflect the appropriate objectives. The student should be required to perform exactly as required by the objectives.
 - (b) They should measure the ability of the student to perform the objectives related to the task, not simply his mastery of the knowledge and skill elements of the task.
 - (c) They should be scored on a pass/fail basis. (Canadian Forces, 1969b, 4-6).

The Ontario Department of Labour in its Modular Training is using the concept of training objectives; however, the objective and performance standards used are not in behavioral terms. For example, Training Block 155 Math - Square Roots, Area and Volume, has the objective,

To enable the learner to solve normal workshop problems which involve calculations of area, volumes and simple geometry.

It also has the performance standard,

The trainee will demonstrate the standard he has attained by applying on the job the knowledge gained in this block to solve workshop problems and will pass the terminal examinations (Ontario Department of Labour, 1970, 1-5).

The question that must be asked about this performance objective is, how, and to whom, will the trainee demonstrate the standard attained by applying his knowledge on the job? Also, would failure to do this negate the fact that he had passed the terminal

examination if that were the case. Or, alternatively, would a failure to pass the terminal examination be negated by satisfactory performance on the job? Furthermore, since no allowance is mentioned for errors, the implication must be that nothing but perfection is satisfactory. This performance standard as written is not a behavioral standard as outlined by Mager (1962, 13) or Smith (1964, 65).

The word "standard" as used in the discussion to this point is a standard of performance. The term "standard" is used in some places, as in Local Apprenticeship and Training Standards for Electrical Contracting Industry (no date), apparently, to mean rules. In one case, however, this research has found that training standards have made provision for an examination and a passing grade (RCA Service Company and the International Brotherhood of Electrical Workers, 1970, 16-17).

The notion of trade standards was found to be used in Germany. A textile mechanic, being tested on completion of his training, must use two knitting machines designated by his employer for up to two hours, and obtain reasonable amount of production. He must also test his product and explain deviations from accepted quality standards. The mechanic must also diagnose and rectify a minor machine malfunction within one hour. In addition the mechanic must demonstrate his metal working skills during a three hour test, and must also prove his knowledge of raw textiles, textile products and textile fabrication, and textile construction (Entwurf Ausbildungsordnung 1969, 17-18).

The standard of performance is also used in the United Kingdom and may be assessed by the following:

The standard obtained during training must have been assessed by the appropriate tests of B.S. [British Standard] 1295 and B.C. 2645 or similar tests that are not of lower requirements. The competency standard achieved must comply with the requirements of the relevant testing authority. A list of some authorities applicable to various types and standards of welding work is shown below:

British Standards Institution
Lloyds Register of Shipping
Ministry of Defence
Ministry of Transport
ARB/AID

(Engineering Industry Training Board, 1968, 19)

The previous excerpt gave consideration to one kind of standard in terms of Smith (1964), that of accuracy; although many would deny that the soundness of a weld indicates accuracy, they would propose that it is an entirely different standard, that of quality, not mentioned by Smith. Leaving that line of thought for the present, an excerpt from the same publication indicated that the production standard of time is an active part of the performance standard:

The last of the tests [approved standards of performance] will be carried out at the end of the period of experience when it is judged that the trainee can reach the required standards of performance in accuracy, quality and time (Engineering Industry Training Board, 1968, 5).

From the Training Research Division, Behavioral Sciences Laboratory, Aerospace Medical Division of the United States Air Force, John P. Foley has written a most important report on performance testing with implications far beyond the military context upon which the reported research was based. On the matter of training course objectives and the tests that are given on these courses, he wrote:

The official objective of formal technical training courses is to teach each airman to perform the specific task that make up the job for which he is being trained. The actual

objective of many of these courses is to teach those behaviors that are tested by the course examinations. The official and actual objectives should be the same. The behaviors measured by the course examinations should be the same behaviors found on the job for which training is given (Foley, 1963, 1).

Foley drew attention to the United States Air Force, Air Training Command Manual, which, on a discussion regarding educational testing and testing of Air Force trainees, reads:

From our public schools and universities, we have a long tradition of this kind of measurement, complete with techniques for making tests reliable, for making them discriminate well among students, for making them of equal difficulty, etc. So far as Air Force Training is concerned, there is only one catch. We are usually not interested in how well a student answers questions on a test. What we really want to know is how well he can diagnose trouble in a radar set, fly an airplane, fabricate sheet metal, repair a motor, or forecast weather.

We should therefore, concentrate our efforts towards student's grading on practical performance or work sample. Tests that duplicate, as closely as possible, the performance that will be required of the student on the job (Air Training Command, 1951, 2, 3-5, Foley, 1963, 2).

Since it would be absurd to see industrial training as serving any other purpose than for improving on-job performance it would appear that the philosophy indicated above should apply equally to training for industry as for training for military applications.

The method of obtaining a validity index for a test by an examination of how well the test discriminates between the upper and lower twenty-seven percent of those tested was questioned by Foley. He remarked that:

One very dangerous assumption that is made in this process is that the test as a whole is valid. When test items are modified or replaced so that all items have a high discrimination index within the examination, it is possible that the examination may be more invalid when measured against an external criterion than in its original form. Referring to this index as a "validity" index has given Air Force school administrators undesired confidence in their written

examinations.

If an objective of a course is the ability to perform a complex behavior with minimum involvement of verbal factors, it cannot logically be inferred, without proof, that a series of written items about the behavior will actually measure the ability of the student to perform the behavior (even though the discrimination index is high) (Foley, 1963, 12).

What Foley is discussing of course is criterion-referenced testing. His thesis is that the performance on the job is the criterion and all tests following training should be referenced to this job performance, and not to some other criterion. Criterion-referenced measures are absolute indicators of performance; whereas, the usual, or norm-referenced, educational measure is relative indicator. The things that are done to norm-referenced measures to improve them are probably injurious to criterion-referenced measures. This is so because variability, what is strived for in norm-referenced testing, is of no interest in criterion-referenced testing (Popham & Husek, 1969, 2-4).

The performance of the student on the actual job is recognized, in Britain, as being the preferred situation. There they wrote,

Testing should be carried out within the workshop whenever practicable, this being the "real" situation.

The successful completion of productive work gives much greater satisfaction than can be obtained when working on specially prepared equipment. When testing is carried out in training centres productive work should normally be used (Road Transport Industry Training Board, no date).

The criticism that Foley expressed on the application of techniques for reliability, discrimination, difficulty, etc. to tests for the mastery of a training course, appears similar to the criticism

of Catell and Butcher who when discussing personality and motivation measurement wrote:

The result has often been that the study of reliability and homogeneity has been carried to extraordinary lengths of pedantic elaboration, whereas the validity issue has been treated quite naively (Catell and Butcher, 1968, 91).

An entirely different aspect of those examinations that bear on an individual's right to work might be coming into view. This is the legal aspect. This aspect is perforce bound up with the psychometric principles of validity and reliability. Hasler brought this aspect into focus, when he wrote:

It is increasingly apparent that there is a need today to use and validate procedures which provide work behavior descriptions of individuals.

At the same time, psychologists and others using psychological tests in business and industry are under increasing pressures from government to demonstrate job performance validity for these instruments. This pressure is emphasized by the March 8, 1971 Supreme Court ruling that employers cannot use job tests that screen out Negroes without realistically measuring their qualifications to do the work. Various other federal regulations stress the need to show that test scores parallel performance levels on the jobs for which the tests are used as selection aids (Hasler, 1972, 12).

Stewart brought out the same point but with much less precision than Hasler; however, Stewart drew attention to the idea that anyone setting and scoring an examination could be asked to prove their conclusions in a court of law (Stewart, 1971, 64).

PRACTICAL EXAMINATIONS

In Holland, the Bemetal Foundation for vocational training in the metal and electrotechnical industry has expended a great effort towards making objective practical examinations for apprentices. In

order to maintain a satisfactory standard of craftsmanship,

... all candidates have to make exactly the same test piece in exactly the same week from exactly the same blueprints provided by Bemetal.

Afterwards all these test-pieces are brought together at a central point, where they are assessed, checked, measured and marked by experts from industry according to identical rules (Bemetal Foundation, no date, 13).

These examinations appear to recognize the behavioral objectives of accuracy and time as discussed by Smith (1964).

In a study carried out in the United States Navy, it was ascertained that 72 percent of the supervisors, in the sample surveyed, believed that practical performance tests were a valid measure of on-job performance; however, only 17 percent were using them. It appeared that the reason that practical tests were not more widely used, is that satisfactory practical tests had not been developed (Harris, 1962, 28).

Possibly such tests were available. They could have been one or a number of tasks from the usual daily work of the person to be tested. Remmers and Gage have touched on the marking of such tasks or products, which is, they say, the non-symbolic activities of educational endeavour. They mentioned the two-fold scoring of these products. This is whether the particular attribute or dimension measured is present or absent, good or bad. However, this they asserted leads to a loss of refinement in evaluation hence they preferred a rating scale. The Remmers and Gage excursion into the scoring of practical work is useful in that it discusses the marking of food-stuffs together with such activities as woodwork and drafting by the same scoring methods (Remmers and Gage, 1955, 153-156).

In Germany, examinations for the journeyman level are set and scored by a panel. On this panel there must be at least three members and all must know the particular trade, also each panel member must be proficient in testing. One member must be a self-supporting tradesman [master], one must be an employed tradesman, and one must be an instructor in the particular technical institute. If there are more than three panel members, not less than two-thirds of the panel must be composed of self-supporting and employed tradesmen (Berufsbildungsgesetz (BBIC), 1970, 23).

In Switzerland, as in Holland, the Employers Federation is now designing the specimen jobs for journeyman examinations in the major metal trades. A similar occurrence has taken place in France, in the major industrial regions of the country, with the result of a definite raising of the standard of workmanship in most instances. Except in France where the examinations are traditionally more difficult, European employers regard the examinations as an over-all assessment of the young craftsman's aptitudes and abilities. The examination therefore, is just a means of differentiating between those who will go on to technical studies, those who will remain as a skilled craftsman and, possibly, a supervisor, and those who will gradually be relegated to repetitious or semi-skilled work (International Labour Office, 1966, 122-125).

EXTERNAL EXAMINATIONS

In technical and craft education there is movement to reduce the rigidity of external examinations as there is movement and pressure

to reduce these external examinations in the formal school (The A.T.A. Magazine, 51-5, 2-3).

In the United Kingdom, the Report of the Committee on Technicians Courses and Examinations stated,

students are no longer required by the [examination] joint committees or the CGLI [City and Guilds of London Institute] to pass examinations - other than informal tests held by individual colleges - at the end of each year of their course. Both national certificate and T [Technician] examinations are based on two or three year units with promotion from first to second year, and second to third year where applicable, at the discretion of the college (1969, 15).

The report gave the opinion that the technical student should at some time be tested in reference to some objective criteria. It also complained that an external examination was "a confining influence on teaching and was liable in any event to give a false picture of the student and his real achievement, and often did" (1969, 42).

With regard to technical examinations as carried out in the United Kingdom there was a very strong plea for more weight in the final grade to the teacher's grading of the student.

In fact, there was a body of opinion in the committee that teacher's assessment should constitute the most important single component in the system of student testing, with other components, externally set or moderated, used as an independent check on the validity of the assessment (Report of the Committee on Technician Courses and Examinations, 1969, 42).

That is, the committee was of the notion that the best use of external examinations was that of quality control.

In the Canadian Forces, the quality control function is vested in the Standards Section at each unit. The Canadian Forces Training System Manual contained the statement:

Standard sections must be so located in the organizational

structure as to be free of undue pressure from the instructional staff. The instructional staff, despite assurances, is likely to feel somewhat threatened by the evaluation system. Since it is natural for people to want to 'look good', it is also natural for pressures to be exerted on the system to bring this about or, at the very least, to keep from 'looking bad'. One way of avoiding this is to involve the instructional staff actively in all quality control operations (Canadian Forces 1969, 3-4).

The above was considered to be a perceptive analysis of the implications of external examinations. And, carrying it a step further and out of the educational environment, it is most perceptive of the quality control function in any industry.

In Europe, apprentices usually only take one examination set by the authority for control of apprentices. This examination is at the end of their period of apprenticeship, although other intermediate examinations are sometimes arranged on a voluntary basis to assist in identifying training deficiencies (International Labour office, 1966, 113).

EVOLVING IDEAS OF APPRENTICESHIP

The industrial revolution sent the apprenticeship system into a decline. According to Ashton, (1964, 78) the early factory masters in England used apprenticeship as a guise for the employment of cheap child labour. This accusation, though, might be unkind, since under the cottage system it was usual for very young children to be apprenticed to a craftsman (Walsh, 1969, 3). It does little good to condemn the cotton masters of Lancashire for the rape of the apprenticeship system for economic gain (Walsh, 1969, 35). Possibly it was the whole fabric of society that did not understand the new

industrialism and the impact that it would have upon the existing institutions, nations, and, indeed, the whole world itself (Walsh, 1969, 107).

It is obvious that industrialism has had two entirely different, indeed, opposing effects on the abilities required of craftsmen. The first is the breaking down of the old crafts into many small parts. This action commenced with the first industrialists as Adam Smith commented in his Wealth of Nations (1920) and was continued by Frederick Taylor and his scientific management (Hoxie, 1916, 15). Smith (1920), discussed the divisions and the deskilling of the craftsman's skill in his celebrated pin factory example. In the example, the pinmaker's craft was broken down into a number of operations: drawing wire, cutting, grinding the point, forming the head, polishing and other smaller operations. From this division of labour, the production of pins would multiply because of the increase in production from each of the operators to whom these smaller tasks were assigned (Smith, 1920, 6). In turn, Taylor and the school of scientific management that he pioneered, studied each of these smaller tasks in order to develop the most efficient method which the worker must follow to maintain his production. This action, workers said, degraded skilled labour (Friedman, 1955, 43; Hoxie, 1918, 135).

Opposing the deskilling and the degrading of the craftsman's skill is the movement, as more sophisticated technologies are applied to industrial process, to require the tradesman to be conversant with new technology to the degree that is necessary in the particular trade

under consideration . It is not difficult to consider trades that have additional demands imposed on them resulting from improved technology. One is that of machinist. This trade has kept pace with modern industry in every way. Modern processes include spark erosion and tape controlled machining (Northern Alberta Institute of Technology 1971, 12). The crafts that technology has bypassed are probably the ones that have died or are dying out. Such a one is the trade of blacksmith (Mergen, 1972, 354).

Writing from France, with perceptive comments on the world scene Friedman noted that,

Concerned industries are now aware that better production is achieved and improved mental health of the work force results if the tasks are not broken down to the point of monotony. Rather the jobs are expanded to give variety and to permit the worker to think for himself (Friedman, 1955, 152).

Apprenticeship in the sense that it is used in modern industrial countries has as its goal the development of skilled tradesmen that are versatile and possess in-depth knowledge of their trades. (Okamoto, 1970, 7; International Labour Office, 1966, 51).

From the previous discussion, it is apparent that apprenticeship has declined under industrial practices that used apprenticeship training incorrectly. It also appears that for increased job satisfaction the worker must be able to carry out a number of jobs, or, to put it differently, he should both have and use a broad spectrum of skills.

Versatility and in-depth knowledge of a trade are not obtained by chance, but are deliberately planned by those, at various levels of responsibility, who are charged with the task of the preparation

of skilled tradesmen. In fact patterns of apprenticeship are evolving that permit more flexibility in training than the rigid craft apprenticeship tradition (International Labour Office, 1966, 189).

In Germany the I.G. Metall, Braunschweiger, Krupp and the ABB plans are designed for the flexibility that appears to be necessary today. These plans propose finding common elements in groups of trades and giving on-the-job training in the general trade area for the first training stage. Trainees with limited ability could complete their training at this point. The more able apprentices could progress to other stages in their training. Each successive stage implied a narrowing of the trade area and also an end point for those who chose to end their training or whose abilities do not permit further progress (Krause, 1970, 8-15).

In Canada, the Ontario Department of Labour followed a suggestion for industrial training that was proposed by the Canadian Manufacturer's Association called training by blocks. Training blocks in a trade area are sufficiently common to be used as a training core for the area. Other blocks offer training suitable for a particular skill or occupation. Each block in the Ontario plan has a terminal objective and performance standard that the trainee must meet in order to receive accreditation for the block. Training blocks are assembled to suit a particular training need (Dempsey, 1970, 16-24).

A system similar in essence to the German and Ontario plans has evolved through the efforts of Britain's Engineering Industry Training Board. This scheme called modular training sets a foundation of broad training. From this foundation multi-skilled craftsmen can

be prepared. The various skills required were identified for each trade, and the necessary training modules for the skill development prepared. The training modules are capable of being assembled in a variety of ways to suit the particular industry and the capacity of the individual trainees (Metcalf, 1970, 25-39).

The International Labour Office noted that the vitality of the European apprenticeship system is apparent in its willingness to change and to adapt to a new industrial world (International Labour Office, 1966, 183). Also noted is that apprenticeship training is in a period of rationalization. The period of apprenticeship is being examined as are training methods, and training syllabi. Also, research projects are being launched to examine many facets of apprenticeship training and to offer solutions to the many pressing problems which have been identified (International Labour Office, 1966, 179-197).

SUMMARY

This search of the literature has brought together from many different sources significant information on the total subject of apprenticeship training.

The use of models in education and training is not at all new (Downey, 1963; Nadler, 1971) but it is a great aid in indicating what should take place and in what order.

Also, there is a false dichotomy between education and training as Bruner (1962) noted the discovery method is not confined to the academic disciplines at all, and it is a matter of record that British studies have used this method to advantage in trades training

(Engineering Industry Training Board, 1971). Furthermore, in both training and more formal educational endeavours, objectives are a necessity (Mager, 1962; Troyer, 1971). This is applicable whether training is carried out in a classroom or on-the-job. In both cases training should be systematic, and in accord with definite and measurable objectives.

The use of measurable objectives appears to be necessary if examinations are to be meaningful. The question of examinations brings up, among others, Foley's (1963) concern that examinations must be valid and reliable measures of on-job performance and he questioned the use of written examinations to measure ability on the job. Hasler (1972) brought the legal question to bear on the subject of tests and measurements in, and for, the world of work.

The question of aptitude testing has been examined. The use of aptitude testing was found to be common in industrial concerns both in Canada and the United States. The need for such testing in apprenticeship schemes has been noted by Johnson (1967). Aptitude testing possibly carries on to merit rating, which, as Tiffin (1962) pointed out, is a systematic method for a supervisor to place on record his judgement of an employee. Although, as Seashore (1962) pointed out, it is a very complex subject, but it is done anyway so it is only proper that it be attempted and recorded.

An examination has been made of the subject of skill. It is not a simple subject. Fitts (1962) pointed out that the importance of motor skills is decreasing, whereas the importance of perceptual skills is increasing as technological changes are embodied in the work place. Fitts also proposed a taxonomy of skills. The

importance of this section is paramount since it is difficult to take measures to train skilled workers without at least elementary notions of skilled behavior from the psychological point of view.

The findings of this search add weight to the proposition that training, like formal education, is a complex undertaking that cannot be attempted lightly. However according to Lynton & Pareek (1967) it is commonly entered into without any clear knowledge of what is to be expected from it. As a result a great deal of money is wasted. The studies indicated that if research findings were implemented in a systematic way this waste could be halted and a valuable investment would be made in manpower resources.

CHAPTER 3

DEVELOPMENT OF THE MODEL

It is not evident from the writings on industrial apprenticeship in Alberta that a complete study of the system has ever been carried out. It is probable that much can be gained from the examination of any on-going system of human endeavour. The least attractive reason for such a study might be to satisfy the curiosity of a particular individual. A very good reason, without suggesting it is the most attractive reason, is to satisfy the public at large that the system studied is healthy, and is carrying out the objectives that were set by society when it was originally instituted. This particular study while probably affected to some degree or another by the two reasons given was motivated by a wish to examine the system of apprenticeship in Alberta against a background of modern thinking in industrial practices, and educational endeavour.

Because of an extensive personal knowledge of the apprenticeship system in Alberta, the decision was made to disregard the existing state of affairs in the Province and obtain information on the topic from elsewhere in the world. From this information, a model for apprenticeship training was developed. The final stage of the study was to apply the model to different facets of the Alberta system of apprenticeship training.

APPROACH TO THE STUDY

1. Letters were written to all the Provincial Departments of Labour, except Alberta, in Canada enquiring for information on apprenticeship training in that Province.
2. Letters were written to the Canada Department of Manpower and Immigration enquiring about studies that have been carried out by that Department pertaining to apprenticeship training.
3. Letters were written to a number of diplomatic and trade missions in Canada requesting information on apprenticeship training in their home countries.
4. Letters were written to a selected number of larger American and Canadian industrial concerns requesting information about apprenticeship programs that they might operate themselves.
5. Letters were directed to different branches of the United States armed forces regarding the methods used to evaluate the trainees to the various trades that are necessary in a modern military organization.
6. An enquiry was made of the Human Resources Research Organization, Alexandria, Virginia of studies that have been made regarding training methods and the evaluation of training.
7. An enquiry was made of the Canadian Armed Forces concerning the training and evaluative methods of the Canadian forces.

8. Enquiries were made of a number of organizations in the United Kingdom regarding aspects of apprenticeship training.
9. Requests were made of Canadian Embassies in a few European countries in an endeavour to obtain information on apprenticeship training in these countries.
10. Enquiries were made of certain industrial organizations and municipal governments in Canada on specific topics.
11. An organized study was made of available library material.
12. Letters were directed to a number of craft unions requesting information on their activities in apprenticeship training.
13. A seminar on educational objectives at the Northern Alberta Institute of Technology was attended.
14. An enquiry was made to the United States Department of Labor requesting information on apprenticeship training and evaluative methods.

Each of these activities was carried out in order to obtain as many new ideas of apprenticeship training as possible that could be embodied into the study.

RESULTS OF THE ENQUIRIES

Each of the fourteen different sets of enquiries was successful in that ideas and useful material were obtained from each of them, directly or indirectly.

The information derived from these enquiries has been reported in the study where it has been considered useful, or practical to do so.

Although, it must be admitted that under the term of practicality there is some French, German, and Belgian information that has not been studied in sufficient detail to warrant its exclusion under the terms of not being useful.

The enquiries to the Canadian Armed Forces proved to be the key to the development of the model. For from one enquiry, to Training Command, there resulted an invitation to attend a one-day briefing at Headquarters, Training Command, Canadian Forces Base, Winnipeg, Westwin, Manitoba. This briefing, as well as providing an overview of the role of Training Command within the Canadian Forces, provided an opportunity for a number of small conferences on different aspects of training with the personnel responsible for the training function in, what is probably, Canada's largest single training organization. The information derived from these conferences is shown in appendix A. This visit also provided an opportunity to obtain literature that is not available from usual sources. One piece of literature was the source of the basic training model that was used in the study.

THE OBJECTIVES OF APPRENTICESHIP TRAINING

Early in the study, it was realized that it might be possible to produce a model for apprenticeship training, but this model would be operating inefficiently unless a framework in which the model would operate was also developed. In other words, the goal or general objective of apprenticeship training must also be defined in addition to the training system.

It was postulated that much of the criticism of apprenticeship that has been heard recently (Singer & Macdonald, 1970, 15-17; Dempsey, 1970, 17), was the failure to both recognize and formulate the objectives of apprenticeship training. Once formulated all parties could work towards these objectives. These objectives may not be permanent and may require revision over time (Lonsdale, 1964, 174). Although consideration does not indicate that the general goals of apprenticeship have changed over time, they certainly have changed in particular regions at particular periods, and because of particular reasons (Lewis, 1955, 161; Ashton, 1964, 78).

An objective for apprenticeship training was formulated for this study and used as a frame within which the training model is purported to operate. This objective is as follows: The objective of apprenticeship training is the development of a worker who can carry out each of the tasks of his trade at the 'experienced worker' standards of time, accuracy, and quality, and who will be well received by good employers, fellow tradesmen, and consumers at large. In this definition there is, by intent, no reference to craft as this word, it is believed, has an emotional content, nor is there reference to skill, since skill in industrial occupations is a continuum or spectrum (Wellens, 1963, 26). The reference to experienced worker standards (Metcalf, 1970, 37), gives recognition to well practiced skills whether psycho-motor or intellectual (Fitts, 1962, 177) as well as behavioral objectives that are measurable (Smith, 1964, 3). What is meant by good employer is an employer (single proprietor, partnership, limited company, government at any level,

or international enterprise) who does a reasonable, possibly average, class of work, with some degree of breadth in the actual shop where the worker would be employed, and with which he would be expected to be reasonably familiar. The reference to fellow tradesmen means those with whom he would be in contact, whether unionized or not, at his place of work. Implicit here is that his degree of skill would be such that he would be welcomed into a craft union. The reference to consumers recognizes that consumers have a right to expect that the articles that they buy or have repaired have been worked on by people who know their jobs or tasks, and who will be responsible for their workmanship or actions.

TRAINING MODELS

When originally conjectured the model for apprenticeship training was one that changed according to the information that it generated itself as well as any information that was fed to it. Study has shown that a number of models purport to do this (McKeon, 1967, 609; Gagné & Fleishman, 1959, 42; Tyler, 1950). It was also originally considered that the model needed for this study would be required to be developed from first principles. The thought behind this was that contemporary apprenticeship plans such as Germany's Krupp plan (Krause, 1970, 10) and the Ontario plan (Dempsey, 1970, 22) illustrated static systems without feedback. The general model as developed by Thomas (1970), though, has the desirable feedback features of Tyler's model and is also job-centered as is necessary for apprenticeship training. However, Thomas' model was for,

apparently, a single course, thus his model has been modified to suit the number of training courses, blocks or modules that are part of modern industrial training (Krause, 1970; Dempsey, 1970; Metcalfe, 1970), as well as in other aspects.

The following discussion relies heavily on Thomas (1970, 17-27), whether specifically acknowledged or not.

BASIC MODEL

The proposed training system, shown on page 67, is constructed from eight subsystems operating within environmental constraints. Each of the subsystems are purported to be reacting with each other and also with the environment. The model is divided and will be analyzed (except the environmental constraint, Objectives of Apprenticeship Training, which has already been discussed) as follows:

- 0.0 Objectives of Apprenticeship Training
- 1.0 Analyze Trade
- 2.0 Establish Terminal Objectives
- 3.0 Select Apprentices
- 4.0 Develop Training Courses
- 5.0 Implement Training
- 6.0 Administer Results
- 7.0 Monitor Effectivity of Training
- 8.0 Conduct Experimental Courses

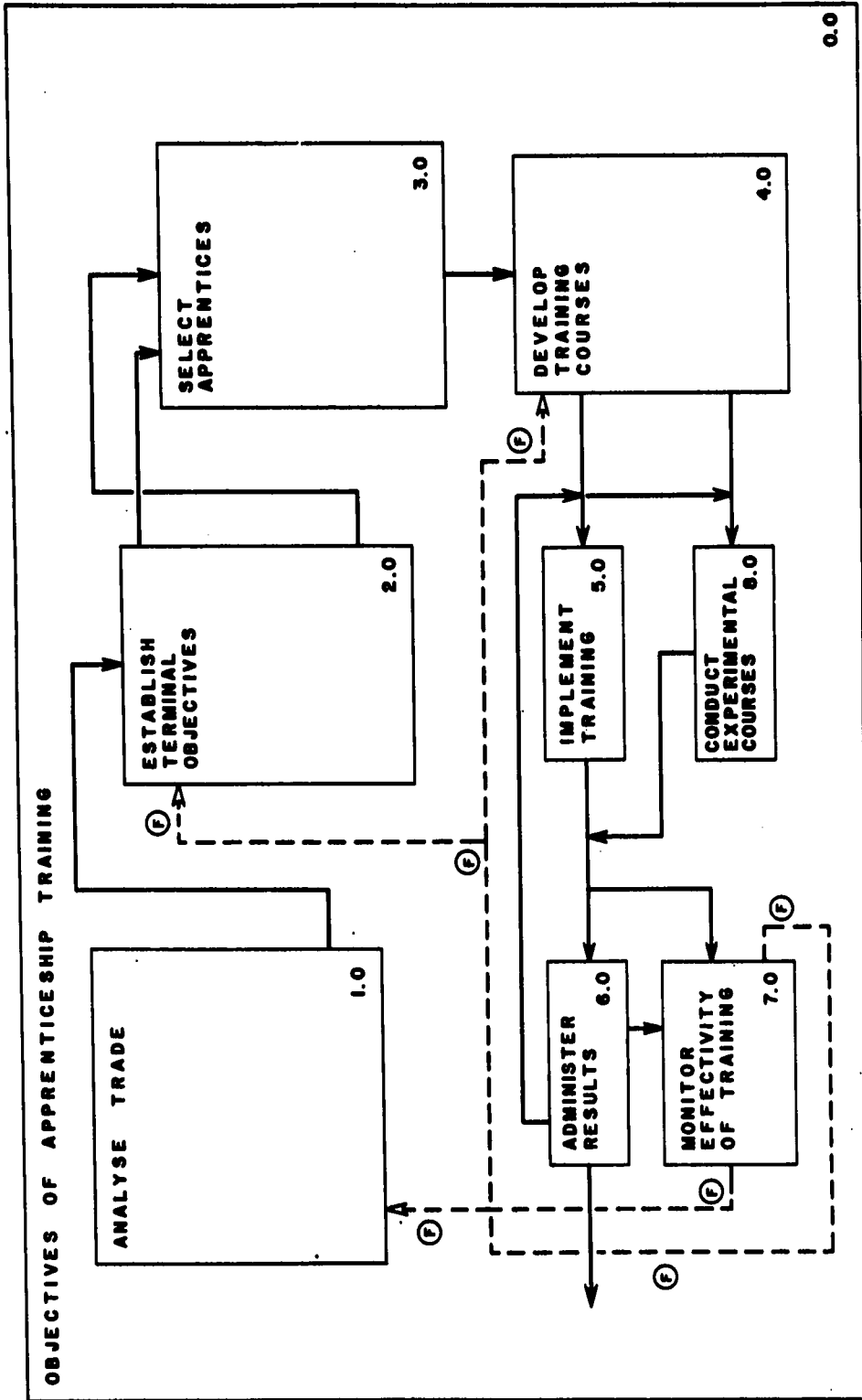

AFTER: THOMAS, D. B. - 1970, P. 26

A MODEL OF APPRENTICESHIP TRAINING
FIGURE 1

Analyze Trade, Subsystem 1.0

The evidence was overwhelming that training course design must commence with an analysis of the job or trade for which the course is to be designed (Seymour, 1966, 171-176; Miller, 1962, 32; Canadian Forces, 1969b, 2-2). This has the target of both valid and complete training as well as efficiency (Miller, 1962, 32).

This subsystem is further divided into three sub-subsystems, 1.1, 1.2, 1.3, each of which are further sub-divided, see page 70. The essential functions of this subsystem is to examine legal, trade union and other constraints upon the trade, develop an inventory of tasks that are expected of the apprentice at each level of experience, and also of the journeyman, and to catalogue the repertory of skills (Hunter et al, 1969, 8). It is also an essential function to review these inventories at least annually (Smith, 1964, 19).

The goal of an instructional system is the acquisition of the skills and knowledge by the trainee for the tasks assigned to his particular level of responsibility (Air Training Command, 1969, 3-1). To delineate the goals for all trades under consideration is the function of this particular subsystem.

Establish Terminal Objectives, Subsystem 2.0

A major function of a training system is the establishment of the training objectives (Stewart, 1971, 87). The contemporary view supported by research evidence is that well-defined job-relevant objectives are more important than training methods (Smith, 1964, 5). Objectives describe the performance or behavior expected of the student

on the completion of a particular block or segment of his training. A particular student may possess the needed behavior and so should not require to take the training specified for the block (Dempsey, 1970, 23), thus saving money for the student, his employer and the training authority.

The subsystem, page 70, is divided into seven sub-subsystems. Some of these sub-subsystems are further divided.

The weighting of practical and written tests could vary from 1.0 to 0.0. This is the same as saying that a training segment could have either a practical test to ensure competency, a written test, or both. Where both practical and written tests are considered necessary, the weight given to each would reflect the importance given to each of them.

However, contrary to the above method of weighting, if a training segment has X objectives and A of these objectives can be assessed by practical tests and the remaining $X-A$ can only be assessed by written tests, the student will be expected to attain both sets of the performance objectives in order to obtain credit for the training block, segment, or stage. This then causes the weighting function 2.2 to be redundant. Contemporary thinking appears to favor the setting of training objectives together with a minimum standard of performance for all tests, rather than weighting different tests with the implication that less than adequate performance might be accepted.

The sub-function 2.4 is part of the validating function of subsystem 2.0. The particular sub-function has the responsibility of

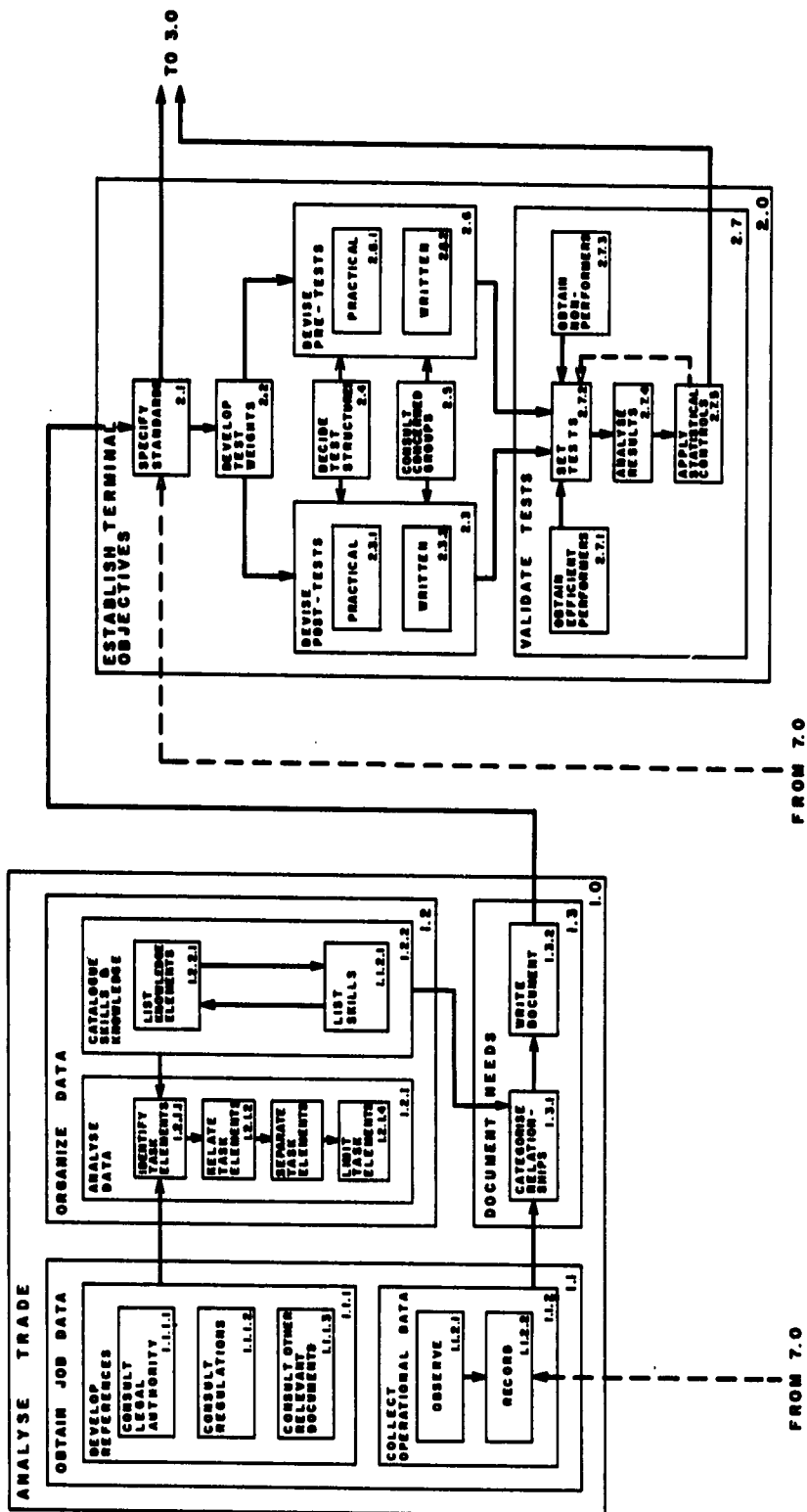

AFTER, THOMAS, D. B. - 1970, PP. 19 & 20

FIGURE 2

deciding how the course objectives are best tested.

The training objectives and the tests that purport to assess these objectives should not be decided by the training authority in isolation but in conjunction with all interested groups (Metcalf, 1970, 26; Holden, 1971, 28). Sub-subsystem 2.5 is identical to 3.5; however, interested groups in 3.5 are given as separate functions which have been omitted from 2.5 merely for reasons of space.

The validating function of 2.7 carried out by 2.7.1, 2.7.2., and 2.7.3 is in agreement with Anastasi (1961, 471) and Smith (1964, 56). If non-performers can pass the test item correctly a skill is not being tested or the test is defective in some way.

The sub-function 2.7.4 is to analyze results of the performance tests. It is usual to test the sub or enabling objective as well as terminal objective. In a hierarchical order there may be a number of levels of enabling objectives under the terminal objectives. An example of a terminal and two enabling objectives one lower than the other are: terminal objective, student will be able to machine a shaft on a centre lathe to a dimension of 1.375 inches plus or minus 5 thousandths of an inch; enabling objective, student will be able to use a one to two inch outside micrometer; lower level enabling objective, student will be able to add together inches and decimal parts of an inch. If more than 15 percent of the students, who fail a sub-level, pass the higher level it is possible that the sub-level is not necessary for successful performance of the task. Similarly, if students pass the lower level objectives, but fail the higher level objectives, it is probable that the organization of

skill and knowledge elements should be re-examined in order to identify missing components of skill or knowledge. Furthermore, as no test is perfectly reliable it might be necessary to lower the standard (Smith, 1964, 59).

In the matter of testing the behavioral objectives of a course Stewart is of the opinion that one-hundred percent of the objectives must be achieved by the student (Stewart, 1971, 100); however, Smith (1964, 59) implies that the number of objectives passed in a test might be varied. The standard of acceptable performance for the Canadian Forces trade of Electrician Level 3 might vary between fifty and one-hundred percent (Canadian Forces 1969a, 3-1).

The function of 2.7.5 is to apply statistical controls to the tests. These controls will vary according to the type and structure of the tests given. In practical tests this could be a matter of adjustment of the time to do the project to the experienced worker standard (Engineering Industry Training Board, 1968, 5; Bemetal, no date, 16). A similar requirement is necessary on written tests to establish a reasonable time for the task to be completed.

It is probable that the usual test statistics found in educational endeavour have no applicability in this view of testing. If there are X objectives in the training block and the skills necessary for these objectives are mandatory in the work situation or as a prerequisite for the next training stage, there is little accomplished by permitting the student to graduate from the stage with less than the necessary skills. With some objectives it will

probably be correct to examine the result if the student has achieved less than complete mastery of the skills. If the error that might result from less than complete mastery is not critical then a passing grade of less than one hundred percent is applicable. However, in either case the test results will be pass or fail and the statistics of average score and standard deviation will not be of interest.

Select Apprentices, Subsystem 3.0

Subsystem 3.0, page 76, has in essence a manpower development function and, because of this, the drawing of the subsystem has certain deficiencies. These deficiencies in the model were retained for reasons of simplicity, but with the intention of explaining matters in these notes.

In any instructional system, the most critical of all the resources is the individual student. The efficiency of the instructional system necessitates that:

- a) instruction capitalizes on skills already possessed by the students
- b) instruction be in accordance with individual potential
- c) instruction, once given, should be fully exploited

Furthermore, instruction should be designed to start with what the student already knows. Prerequisites for entry into a course of training must, therefore, be carefully specified. This specification must, then, be based upon the best estimates of the human resources available. Efficient programmes are attained by careful determination of numerical requirements and realistic recog-

dition of the student's potential and capacity (Air Training Command, 1969, 5-3).

This should never be construed that those not possessing the minimum educational requirements should be cut off from further training. What must occur is that prerequisite training should be made available.

Sub-function 3.3 is necessary in an efficient programme of manpower development. Rarely are the numbers of apprentices consciously geared to the actual need for new workmen as revealed by attrition or changes in the demand by the economy (Kuhn, 1967, 473). Now, it appears, in Canada sub-functions 3.2 and 3.3 are within the abilities of Statistics Canada to carry out (Hills, 1971, 1). This should then only leave regional adjustments to be made by the training authority.

Some functions of subsystem 3.4 are minor and others significant but all nevertheless necessary.

The minimum age is probably set by the school acts in all areas (School Act, s. 133, 1).

Health is another matter. It appears only reasonable because of differing demands made upon workers in different trades that the ability of the trainee to maintain the physical demands of the work should be considered (State Labour Office, 1964, 16).

There appeared to be a demand for the aptitude testing of all types of industrial trainees as Hammer (1950, 23) and Johnson (1967, 21) have noted in their studies in both the United States and Canada. Private industrial organizations in North America were found to have aptitude testing as a requirement for apprentices (Personnel

Development Centre, no date, 1), so have trade unions (National Joint Committee, 1966, 2). Such widely separated places, both in distance and economic standard, as Holland and India require aptitude testing in State training schemes (State Labour Office, 1964, 14; Anand, no date, 1). Canada Manpower, it was found, used the General Aptitude Test Battery, but did not as a rule test clients for employers (Wass, 1971).

It is traditional, it appeared, to require minimum educational standards for trainees, sub-function 3.4.4, (Provincial Apprenticeship Board, 1970b). However, research is needed to discover the kind of basic education workers should have. Although the general view is for more education to all while young and at school, as yet there is no conclusive evidence that this is the best course. It may be of greater efficiency and effectivity to provide the additional education later in life as the need for it is indicated (Wilkinson, 1966, 100).

With one exception, that of 3.6.2, the functions carried out by sub-subsystem 3.6 are routine administrative functions. The function of 3.6.2, though, is most important if apprenticeship is to be other than a source of cheap labour. The apprentice must learn his trade from skilled workers in a systematic manner. Apprenticeship under other conditions than these should not be tolerated (Editor, 1966, 4).

The function of 3.5 has been discussed previously when sub-subsystem 2.5 was discussed. Nevertheless, emphasis must be placed on it at every opportunity. This function gives the opportunity for the training system to react with, and to receive input, from its

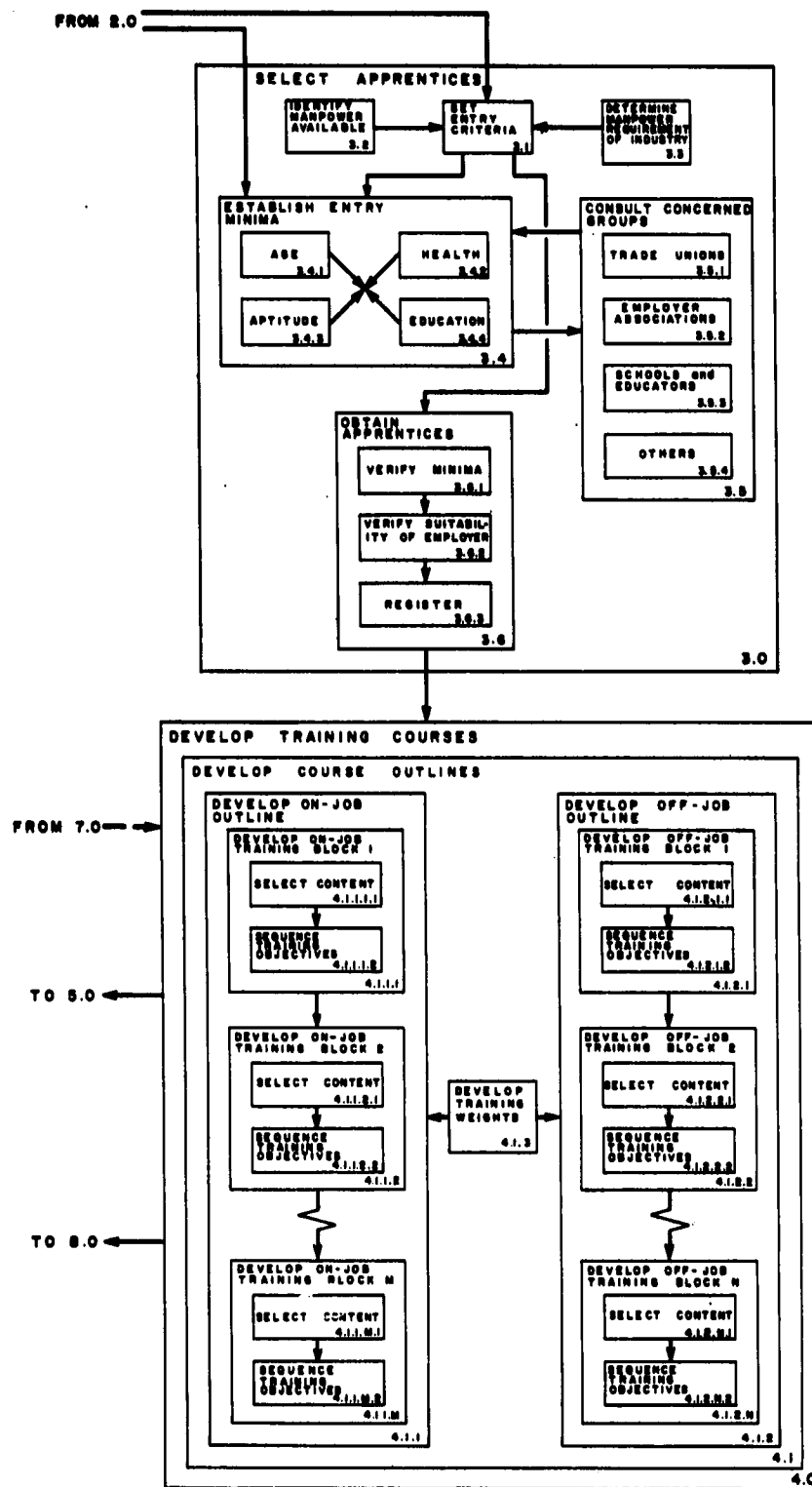

AFTER: THOMAS, D. B.
1970, p.p. 19 & 20

SUB-SYSTEM 3.0 & 4.0 OF THE MODEL

FIGURE 3

environment. In Canada, concerned groups must include associations of the native people and associations of the Metis, and the apprentices themselves (Dyck, 1970, 23 & 91; Ziegler, 1970, 25; Metis Association of Alberta, 1970).

Develop Training Courses, Subsystem 4.0

The function of subsystem 4.0, page 76, is to develop the on-job and off-job training courses to enable the students to attain the objectives for the trade that were established in subsystem 2.0.

The sub-function 4.1 should be the responsibility of professional vocational-educators who know the population to be trained, the facilities available, and also are able to compile learning packages, resource units and have the competence to identify teaching aids and programmed materials that will be necessary if all the students are to attain the terminal objectives specified (Saylor & Alexander, 1966, 24).

Training by blocks, stages or modules is the modern notion of industrial training (Krause, 1970; Dempsey, 1970; Metcalfe, 1970; Damm, 1971). There are basic philosophical differences between these three types of training. The German system, training by stages, has the training time fixed, as terminal-skills and the amount learned are the variables. The British system, module training, and the Ontario system, training by blocks, have the terminal skills fixed, here training time and amount learned being the variables. Having time as the variable hence giving cognizance to individual differences would indicate the pedagogical superiority of module

training, and training by blocks over training by stages.

Under the system of module training, a trainee is first given a one year off-job training to give a broad coverage of the trade area following which he takes two on-job training modules in his field of interest. At this point he is recognized as a skilled craftsman, although training is not intended to be complete on attaining this status for he may take as many of the skill modules as he desires. During the period that the trainee is taking modules of on-job training he is encouraged to take off-job training courses in theoretical subjects. Time off, by day or block release, is given for this purpose. It is suggested that it takes about six years to develop a skilled craftsman under this approach (Metcalf, 1970).

The system of training by blocks has many similarities to module training. A significant difference though is that under the system of training by blocks there is no system of off-job training that purports to give breadth to the training. Instead there is a matrix of training blocks from which the trainee can select to suit his interests and the need for the job that he holds. The matrix includes both on-job and off-job blocks, and a number of them are common to more than one trade area. At the present time to reach the level of journeyman approximately twenty training blocks are required to be taken at the rate of at least five blocks per year (Dempsey, 1970).

It appears that the two systems are not incompatible and a decided advantage could accrue if the essence of the module system were used for young entrants to industry, and that of block system

were used for the older worker who desires and has the opportunity to go into an area for which he requires training.

There are two important ideas common to both systems. One is that on-job training is the responsibility of the employer, the other that there are definite objectives to each block or module which must be attained by the trainee. It is considered that these two ideas will generate two equally important results: one, skill training being the responsibility of the employer will cause him to take a greater interest in it, the other result, having meaningful objectives for each segment of training, will motivate the apprentices.

It is recognized that the block system and the module system might only be satisfactory in organized urban areas. It will probably be necessary to provide additional training to those apprentices in rural areas where the employer might not have a satisfactory level of business to provide the necessary training (Moran, 1970).

Implement Training, Subsystem 5.0

Traditionally the subject of apprenticeship training would be the function of this subsystem, page 81, but in this model many of the traditional functions, if indeed they were recognized or existed at all, have been taken over by other subsystems. Thus the function of this training segment is to do exactly what job analysis has found it necessary to do in terms of terminal objectives, and in the sequence found advisable in the development of the course of training.

The model supposes that the apprentice is responsible for one

unit of training (block or module) at a time, and that he stay with that particular block until he achieves the objectives set for it. Despite this, there is probably no good reason why the student could not occupy himself with an off-job training block at the same time as he is working through an on-job block. The off-job training block, of course, might be any one of evening, day release, or correspondence courses.

Administer Results, Subsystem 6.0

The function of this subsystem, page 81, is almost purely administrative, although for the unsuccessful apprentice a counselling function is implied.

For the apprentice who has successfully completed a segment of his training the fact is recorded and he is directed to the next segment of training. In this way all the segments of training required to meet the objectives for skilled worker status in his trade are fulfilled. Finally, he is issued with the appropriate certificate to indicate that his period of apprenticeship has been completed.

It is implied that the time taken by the apprentice in any training block should be dependent only upon his ability to learn; however, practicality will dictate, as will the economic pressures of the market place, that the apprentice who is unable to meet the objectives of a training block will be requested to consider training in an area that is more in keeping with his abilities. Thus the decision either to train in a different area, or to terminate training, will have to be made in some circumstance or other.

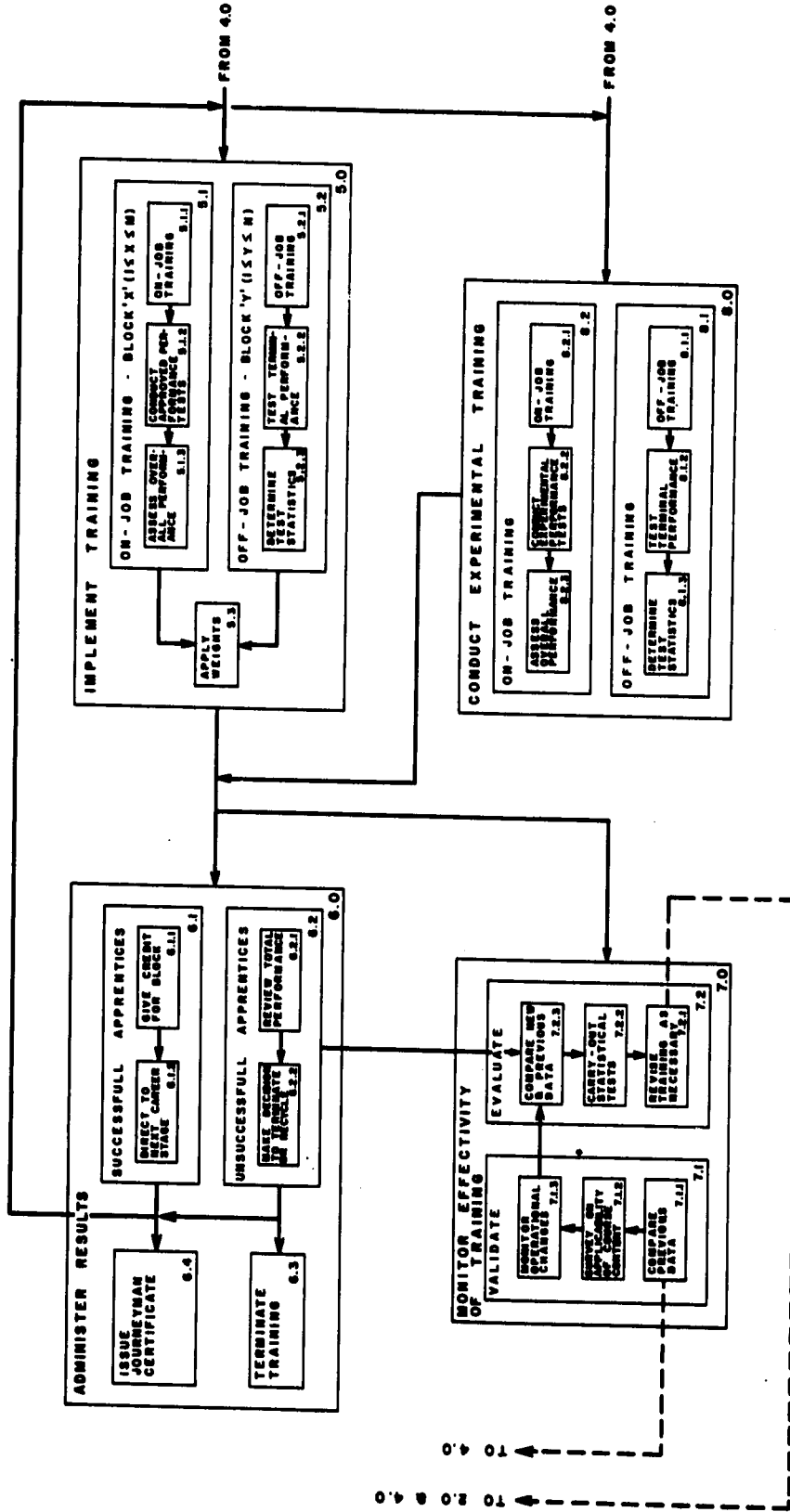

AFTER: THOMAS, D.B. - 1970, P.P. 19 & 20

SUB-SYSTEM 5.0, 6.0, 7.0 & 8.0 OF THE MODEL

FIGURE 4

Monitor Effectivity of Training, Subsystem 7.0

In essence the function of this subsystem, page 81, is that of quality control. One of the purposes of this control is that of deciding whether a given apprentice has actually attained a given objective of a training segment. Another purpose is to obtain information pertaining to the success of the training subsystem, 5.0, in attaining its objectives. Programmes of instruction, or training, tend to be subject to deterioration if provision is not made to monitor them. To summarize, the quality control function is an effective means by which those who are paying the bills for training can determine that the processes are working and the published objectives are being attained (Smith, 1971, 97).

In a course of off-job training the appropriate measure of training effectiveness is the proportion of course objectives attained by the students, or:

$$\frac{A}{BC}$$

where:

A is the total number of objectives attained, for all students

B is the total number of objectives that the test purports
to measure

C is the total number of students taking the training course

From this ratio and all costs involved, such as the following: instruction, materials, space, training allowance, wages deferred, it is a simple matter to arrive at the cost effectiveness of the training (Smith, 1966, 65-66). Such a ratio as the effectivity of

training, would, possibly, not be applicable to on-job training.

When an instructional function has been implemented it must be evaluated to ensure that the end product of the system, which in this system are skilled tradesmen, or tradesmen who are on the way to being skilled by having attained the objectives of one or more training segments, are meeting the needs of industry. This task in the subsystem is separated into two sub-functions: Validate, 7.1 and Evaluate, 7.2 (Hunter et al, 1969, 20-30).

The sub-function 7.1.1 is self explanatory. It requires that previous data be reviewed. The sub-function 7.1.2 concerns itself with obtaining feedback from trainees and from their supervisors regarding the applicability to the job of the material that they have been taught on an off-job training course (Hunter et al, 1969, 55). The sub-function 7.1.3 is similar except that it looks for improved performance on the job as a result of the training (Hunter et al, 1969, 59). All of these activities comprise validation of the training. Validation is an activity of soliciting and using information from the field to improve the training (Canadian Forces, 1969b, 5-1).

The evaluating function of sub-subsystem 7.2 is that of evaluating the training course. Information must continually be checked to ensure that the objectives of the training system are being met. Statistics should be tested for significance, and if there are differences in the graduates because of failure to meet the objectives of the system or the needs of industry have changed then, the training should be revised (Air Training Command, 1969, 3-5).

Conduct Experimental Training, Subsystem 8.0

The training system must be kept abreast of changes in the technology of training as well as in changes in the technology of industry. General ideas of what training will be needed in the future are inadequate to guide us through different technological developments (Air Training Command, 1969, 6-1). New forms and methods of training cannot just be allowed to grow. An effective plan of research is mandatory in order to guide, check and to support the training (Metcalfe, 1970, 36). Thus an experimental training subsystem, page 81, must be considered a part of the training model.

CONCLUSION

Each of the subsystems has been discussed as isolated entities. This discussion, carried out for the purposes of clarity, has omitted the essence of the systems approach that the system is an organic whole working towards an objective. Thoughts towards departmentalizing or compartmentalizing any of the functions away from, and out of perfect communication with the rest, will destroy the system.

The whole idea of the model was that it is a living system with channels of communication that are wide open for the forward and backward flow of information. Thus the system will be subject to unceasing adjustments in response to the information that flows along its own channels as well as that received as input from its environment.

CHAPTER 4

APPLICATION OF THE MODEL

A system is like a living thing that is constantly adapting to changes in its environment. A training system is no different than any other system in this regard. Change must be continuous. If training is education, and some of the literature that has been examined as part of this study indicate that it is, then the notion of constant change and adjustment is in agreement with the writings of Tyler (1950, 80).

This phase of the study was devoted to applications of the model to demonstrate the operation of some of its subsystems. However, because this proposed total system of training has not been instituted, these applications of the model were, of necessity, confined to static situations.

Different facets of apprentice training, currently provided according to the existing training method, were examined using various individual components of the model. It has been indicated in this chapter how many findings would be handled within the training system as developed in the study. It will be recalled that the training function itself is outside the scope of this study. Further to this, the different facets of training that were examined were also in different trade areas and with groups of apprentices who were in different stages of their training.

These tests together with the trades and the stages of training that the particular apprentices were taking are listed below.

Also noted below is the part of the model first involved in the test.

First-year Cooks. An examination was made of the validity of this trade's off-job training. This examination would be carried out by subsystem 7.0, Monitor Effectivity of Training. The particular component involved is 7.1.2, Survey Applicability of Course Content.

Second-year Radio-T.V. Technicians. An assessment was made by a panel, independent of this research, of the Provincial Apprenticeship Board examination for this trade and stage of training. Provision is made in subsystem 2.0, Establish Terminal Objectives, for consultation with groups outside the training system. This component is 2.5, Consult Concerned Groups.

Third-year Plumbers. An assessment was made of the examination that was written by this group on the completion of their off-job training. This examination was set, administered, and scored by the Provincial Apprenticeship Board. The examination has been described in general terms, and an item-analysis was made on a section of the examination. This would be carried out in subsystem 2.0, Establish Terminal Objectives by 2.7, Validate Tests.

Fourth-year Automotive Mechanics. A number of tests were carried out with this group. One of these was an assessment of the apprentice by his supervisor. This would be carried out by subsystem 7.0, Monitor Effectivity of Training, as part of the validating function of 7.1. Indeed such a test would be carried out by 7.1.3, Monitor Operational Changes. Another test on this group was an assessment of the place at which they work. This test would be the responsibility

of subsystem 3.0, Select Apprentices, this responsibility is delegated to component 3.6.2, Verify Suitability of Employer. From the scores obtained from the assessment of the apprentice and of his place of work, a criterion score was developed. This criterion was then compared with a score obtained from 5.0, Implement Training, in particular from 5.2.2, Test Terminal Performance. It was also compared with a peer rating. This rating could be seen as part of the function 7.2, Evaluate. Finally, all the scores obtained in this section were compared with the scores obtained by each apprentice on the Apprenticeship Board examination.

Apprentices' Views of Examinations. Another test that was carried out was a survey of apprentices' views of the examinations of the Provincial Apprenticeship Board that they had written. The groups that were surveyed were second-year instrument mechanics, second-year Radio-T.V. mechanics, third-year welders, fourth-year automotive mechanics. This survey was seen as one of the functions of component 2.5, Consult Concerned Groups. The position was taken from Dyck (1970, 91) that the apprentices themselves were one of the groups who were concerned both with training and the testing phase of the training.

Thus the application of the model could be separated into five tests with eight different groups of apprentices. None of the apprentices that were involved in this series of tests were in more than one group. Also these tests involved all the subsystems of the training model except 4.0, Develop Training Courses; 6.0, Administer Results; 8.0, Conduct Experimental Training.

AN EXAMINATION OF THE VALIDITY OF THE TRAINING
COURSE GIVEN TO FIRST-YEAR APPRENTICE COOKS

In order to obtain an opinion of a group of apprentices on the validity of their training for the job that they actually do, a mailed survey was chosen as a method. This method of obtaining feedback data for the evaluation of training was reported by Hunter et al (1969, 20).

Method The Provincial Apprenticeship Board provided the names and mailing addresses for eighteen first-year cook apprentices who had taken a training course at the Southern Alberta Institute of Technology from January 4, 1971 to February 24, 1971. This was the total number of apprentices taking the course.

A questionnaire was developed from the course outline for the trade (Provincial Apprenticeship Board, 1968) and is provided in Appendix B.

The questionnaire asked two questions:

Question A: Was your first year training adequate for this task? Two possible responses were provided: Yes - No.

Question B: How often do you perform this task? Three possible responses were provided: Never, Sometimes, Often

The questionnaire with a covering letter and a stamped addressed envelope, together with a one dollar bill, to pay for their time in filling out the questionnaire was mailed to each apprentice whose name was on the list provided. The covering letter is also shown in Appendix B. No follow-up letter was sent.

<u>Results.</u> Questionnaires mailed	18
Questionnaires answered and returned	11
Questionnaires returned not answered	1
Questionnaires returned, addressee not found	3
Questionnaires not returned	3

There was a sixty-one percent return of useful questionnaires. The responses to the questionnaires were tabulated and are shown in Appendix B.

AN INDEPENDENT STUDY OF THE SECOND-YEAR
RADIO-T.V. TECHNICIAN EXAMINATION OF
THE PROVINCIAL APPRENTICESHIP BOARD

The reduction of authoritarianism in education and the increased emphasis on participation in educational decision-making by many groups in society today (Dyck, 1970, 91) is probably just as applicable to the training of apprentices as it is to schools, colleges and universities. Thus it is seen that independent groups should be encouraged by the training authority to examine its operations and procedures.

To this end an independent board was convened. The board was asked to review the examination of the Alberta Apprenticeship Board for second-year Radio-T.V. apprentices.

It was originally intended to be a three member board; however, last minute difficulties prevented this and so a two member board was used. The members of this Board were: G.R. Rose, Ph.D. and Mr. P. Woloshyn, P. Eng. (Electrical). Dr. Rose is a holder of a

certificate as a journeyman in the electronics trade, Mr. Woloshyn was a graduate student in the Faculty of Education, University of Alberta, at the time of the study.

Method. A set of six criteria were developed that were considered pertinent in a validity assessment of a written trade examination. These criteria reflect some of the criticism of examinations that the writer has encountered, and also reflect the written views of some apprentices (See, The Apprentice's View of Board Examinations, Appendix J). These criteria were presented to the Board, see Appendix C, and are reproduced below.

1. The examination questions should be limited to material in the published curriculum for the trade.
2. Each question should be clear and unambiguous.
3. If the questions are of a problem solving type it should be possible to obtain one and only one answer and this answer should agree with the answer key. For questions of other types the possible answers should be acceptable to a person knowledgeable in the trades and the answer key should indicate the various answers possible.
4. The questions should not depend upon other abilities, such as reading ability, or knowledge, other than trade knowledge for a successful response.
5. The questions should be couched in terms that are both applicable and acceptable to the trade in question.
6. The questions should reflect current trade practices, that is they should be up to date.

A sheet was prepared numbered from one to ninety-five on the left side to accommodate the possible number of questions, and numbered from one to six along the top for the criteria. A series of letter pairs SU, were typed on the sheet to coincide with the questions numbered and each criterion number. This sheet entitled

Examination Question Validity Assessment List is provided in Appendix C. The panel was requested to list the examination questions according to the criteria by circling S or U which ever was applicable.

In order to obtain a view of the distribution of questions on the examination in reference to the published course outline, the panel was also requested to write the question number in the relevant box of a Question Distribution List which was provided. This sheet is also provided in Appendix C.

Results. There were eighty-three questions on the examination.

- Criterion 1 - All questions satisfied this criterion.
- Criterion 2 - Thirteen questions failed to satisfy this criterion.
- Criterion 3 - Nine questions failed to satisfy this criterion.
- Criterion 4 - One question failed to satisfy this criterion.
- Criterion 5 - Three questions failed to satisfy this criterion.
- Criterion 6 - All questions satisfied this criterion.

The reviewing panel distributed the questions as shown in Appendix C. The various divisions of the distribution are subject divisions mentioned in the course of study for the trade (Provincial Apprenticeship Board, 1967). Some questions could be placed, apparently, in more than one division.

The Chairman of the panel, Dr. G.R. Rose, who expanded on the panel's findings, wrote:

The panel was for the most part impressed with the overall quality of the examination. There were, however, certain negative aspects which needed to be indicated. They

were:

1. Some questions displayed a degree of ambiguity. These questions appeared open to a variety of interpretations.
2. Four or five questions could be classified as containing terminology no longer widely used in the trade.
3. Approximately six of the multiple-choice questions had more than one correct answer.
4. A few of the questions did not appear relevant to the evaluation of the goals of the course studied.
(Rose, 1971)

A REVIEW OF THE PROVINCIAL APPRENTICESHIP BOARD
EXAMINATION FOR THIRD-YEAR LEVEL
PLUMBING APPRENTICES

This examination was designed to be completed within three hours and was divided into two sections: plumbing and gasfitting. The plumbing section was composed of seventy-three multiple-choice, thirteen short-answer questions and one question that was an elevation drawing of a residence that required a few lines drawn on it to show how, in a general way, certain plumbing should be installed. The gasfitting section contained twenty-six multiple-choice, and nine short-answer type questions.

The examination questions were contained in a prepared booklet with the exception of the drawing in the plumbing section. This booklet also contained the tables that were necessary to answer the questions.

A separate answer booklet of three sheets was provided. One sheet was used for all the questions in the plumbing section except the drawing, one sheet was used for the drawing, and one sheet was

used for the gasfitting section.

A templet was used for scoring the multiple-choice questions, and a key was used to score the short-answer questions. The drawing can only be scored by someone knowledgeable in the trade area. At the time of the review, the examinations were scored by a certified plumber, although all the questions except the drawing, and perhaps the short answer type, could have been scored by clerical workers.

The test booklet did not describe any objectives of the test, nor did it give any statement as to the number of questions that had to be correctly answered from each part, if any.

The specific test on this examination consisted of an item analysis of both sets of multiple-choice questions. This was done in order to ascertain the difficulty level of each question, and to obtain a measure of the discriminatory power of the questions by means of coefficients of biserial correlation and item reliability index.

Method. The answer booklets for a total of ninety-four apprentices who took the Apprenticeship Board examination for third-year plumbers in October and December 1971, at both the Northern and Southern Alberta Institutes of Technology, were made available for the study by the Apprenticeship Board.

The students' responses to the multiple-choice questions were transcribed to general purpose answer sheets for computer scoring. The multiple-choice questions in the plumbing section of the test were numbered from one to seventy-three on the general purpose answer sheets, and the multiple-choice questions in the gasfitting section of the test were numbered from one hundred one to one hundred

twenty-six. The answers were transcribed by two persons and were checked by the same two persons.

An answer key was not provided but was developed from the student's test booklet in the following manner. The scorer using the scoring templet left the response unmarked if it was correct, but if it was incorrect a red circle or cross had been made at the correct response. Thus the score for the multiple choice answers was obtained, apparently, by totalling the number of red marks, or incorrect answers, and subtracting this quantity from the total possible score. Thus a key was developed for each question by taking the student's response if there was no red mark against the question or taking the response that was marked in red, whichever was applicable. The key was checked on three separate answer booklets and it agreed in each case.

The facilities of the Alberta Department of Education, Division of Operational Research were used to analyse the test information from the general purpose answer sheets. The data were returned by means of a computer print-out and the relevant statistics are reproduced in Appendix D.

Results. Since no behavioral objectives were published for the course of training for third-year plumber apprentices, it must be assumed that the multiple-choice questions were designed to provide scores that approach a normal distribution, see the diagram in Appendix D, as is usual with multiple-choice examinations in the usual educational context. With this assumption a simple, but effective interpretation of item analysis, the booklet by Wood et al (1968), was used.

According to Wood, and his committee, the acceptable limits for elements of item analysis are as follows: the analysis should be based on a minimum of 100 students; the difficulty index is acceptable if it ranges between 0.200 and 0.800; the biserial correlation is acceptable if it is greater than 0.300, the higher the biserial correlation the greater the discriminatory power of the item between the better and the poorer students; the item reliability index is acceptable if greater than 0.150, it is disregarded if the biserial correlation is lower than 0.300. An acceptable biserial correlation becomes more dependable as the item reliability index increases towards its maximum of 0.500 (Wood et al, 1968, 5).

The number of students from the two technical institutes and the two writing dates of October and December was ninety-four. This number, while below the minimum, in the practical situation of this study was considered to be acceptable.

Using these criteria to examine the plumbing section of the examination it was found that only twenty-two items of the total seventy-three were acceptable multiple-choice questions, that is 30.2 percent of them. Fifty of the questions were within the acceptable range of difficulty, and thirty-one of the items successfully discriminated between the upper and lower students by having a coefficient of biserial correlation greater than 0.300. Indeed, four items had a negative biserial correlation coefficient and so discriminated in favour of the lower group rather than the upper one. Finally there were five items although having an acceptable biserial correlation coefficient had an unacceptable item reliability index,

that is this index was below 0.150.

A similar situation existed in the gasfitting section of the examination. Eight test items out of the twenty-six, 30.8 percent, were acceptable according to the criteria (Wood et al, 1968, 5). Of the total twenty-six test items, fourteen had a difficulty index between 0.200 and 0.800; ten had satisfactory discriminatory power as indicated by a biserial correlation coefficient greater than 0.300; and four items with a satisfactory biserial correlation coefficient had an item reliability index below 0.15, hence rendering the biserial correlation coefficient unacceptable.

FOURTH-YEAR AUTOMOTIVE MECHANICS

Evaluation of Apprentices by Supervisors

Each of us wherever we work and whatever we do are evaluated by others. When we work for another person or are supervised by some one, we are evaluated in some way or another. This study has shown in Chapter 2 that many studies have been carried out on the performance of people at work. Since apprentices are going to be evaluated by some means or another it seemed necessary to make an attempt to quantify this evaluation and so attach a number to the evaluation.

Method. A rating form was designed for this study, and is provided in Appendix E. This rating form, Apprentice Performance Rating Form, owes much to the Employee Performance Rating Form, PAO-5, of the Province of Alberta.

The designed form has ten aspects on which to rate the apprentice. Each of them are considered to be aspects that a super-

visor would consider in the evaluation of a worker. These ten points are assessed on a ten point scale. Hence the highest possible score is one hundred.

This instrument was used on a class of fifteen fourth-year automotive mechanics who were taking the final in-school portion of their apprenticeship at the Northern Alberta Institute of Technology during June and July 1971. Following this training they were certified as journeymen tradesmen.

The purpose of the study was discussed with the whole class, and each individual was asked, separately, if they had any objections to taking part in the study. None of them objected in any way. Following this each apprentice was asked to write down his own name, the name of his supervisor, the name of the firm for which he worked prior to taking the in-school training and the address of the firm. The important characteristic of these work places are shown in Appendix E.

The rating was done by two inspectors engaged specifically for the purpose. Inspector A was of the Ukranian culture and was raised on a farm in rural Alberta but resided in a large city for a long time. Following a high school education in a small Alberta town he attended the Southern Alberta Institute of Technology taking a two-year course as an automotive technician. He did not work at this trade but at the trade of a steam fitter. He followed the usual apprenticeship pattern and was certified as a journeyman in the trade. This inspector was aged 35 and, at the time of the study, was an instructor at the Northern Alberta Institute of Technology. Inspector

B was of Anglo-Saxon background and was also raised on a farm in rural Alberta. At the time of the study he resided on an acreage a few miles from the boundary of a large city. This inspector following a high school education in a small centre attended the Southern Alberta Institute of Technology taking a two year course in aircraft maintenance. He was the holder of a license as an aircraft maintenance engineer and has worked at this trade at points in Alberta and in the Canadian Arctic. This inspector also has taken the two-year instrumentation technology course of training at the Northern Alberta Institute of Technology. He was aged 36, and at the time of the study, was employed as an instructor at the Northern Alberta Institute of Technology. Thus it may be seen that both of these persons appeared to have background that permitted them to completely understand both the rural and urban scenes of Alberta, and that also made them at home in the usual work situation that exists in Alberta today.

The inspectors, separately, visited each of the establishments listed by the apprentices as the places at which they worked prior to taking the final in-school training of their apprenticeship. In general, the routes taken by the inspectors were in the reverse order of each other, but not absolutely so. Changes had to be made because of impassable roads and for their personal interests.

At each of the work places the inspector interviewed the apprentice's supervisor. During this interview he questioned the supervisor regarding the ten different facets of the apprentice's behavior at the work place. From the answers to these questions the

inspector rated the apprentice on the Apprentice Performance Rating Form.

This method of rating a worker by means of an interview with his supervisor is unusual. The common method is that the supervisor himself rates the worker. However, the use of supervisor's ratings was rejected for this study in an attempt to obtain consistent ratings.

Results. The results of this rating by the two inspectors is shown in Appendix E.

Evaluation Of The Work-Situation

It is only reasonable to suppose that work situations or work places differ in quality when they are regarded as training situations. This has been noted in Chapter 2 as being a common notion in Europe. This section of the study was an attempt to quantify these differences in different workshops.

Method. A rating form was designed for this study, and is provided in Appendix F. This rating form, Work-Situation Rating Form was developed from the ideas brought out in Chapter 2, that is, in apprenticeship the training, or the major portion of the training, must be done on the job at the apprentice's place of work. The apprentice's supervisor and the journeyman with whom the apprentice works are his instructors.

The Work-Situation Rating Form has ten different aspects that research points to as significant. To each of these aspects there is a ten point rating scale. Thus a maximum score of one hundred is

possible.

This instrument was used to rate the work-places of the same fifteen apprentices in the June-July 1971 class of fourth-year automotive apprentices at the Northern Alberta Institute of Technology mentioned in the previous section.

During the interview with the apprentice's supervisor in which questions were asked on the performance of the apprentice, questions were posed from which the work situation itself was rated.

Results. The results of this rating of the work situation by the two inspectors is shown in the Appendix.

Weighted Performance of Apprentices

An extension of the thesis that there is a difference in the quality of different workshops as training situations, was the notion that a worker who is satisfactory for one particular establishment may not be satisfactory at another. This might be because different qualities or classes of work could be done at these different places, or that the respective supervisors might have differing commitments to their roles as trainers. An example of this idea is that of a cook trained in high quality French cuisine at an exclusive hotel restaurant who probably would not be a satisfactory worker at a drive-in restaurant in the hamburger and fried chicken trade, nor, probably, would the cook from the drive-in restaurant be acceptable to the hotel restaurant, although in their usual work environments each may be looked upon as a satisfactory worker.

Consequently, the rating of an apprentice will be done

according to the demand of his particular work-situation. In this particular section of the study an attempt was being made to develop a criterion which might be meaningful because the work-situation is taken into account.

Method. The mean rating of the apprentices by their supervisors was weighted by multiplying it by the mean rating of the work-situation. The product was divided by one hundred and rounded to the nearest integer. This information is shown in Appendix G.

Rating Of Apprentices By Forced Distribution Method

Another experiment to obtain a measure of the work performance of apprentices used the forced distribution method (Tiffin & McCormick, 1958, 215). The same group of fourth-year automotive mechanic apprentices that were in attendance at the Northern Alberta Institute of Technology during June and July 1971, for the in-school portion of their training was part of this experiment also.

Method. Two of the Technical Institute instructors who instructed this class in the 'shop' portion of their in-school training were requested to rate the class members by placing them on a five-point scale. This took place at the end of the seventh week of training.

The scale used required placing the group according to the following non-rigid guideposts:

Lowest 10%, Next 20%, Middle 40%, Next 20%, Highest 10%

The lowest was given a score of 1, and the highest a score of 5. With a class of fifteen objects adherence to the percentage grouping

would require: Lowest 1.5, Next 3.0, Middle 6.0, Next 3.0, Highest 1.5. However, with people such grouping, of course, is impossible. Thus the instructors were asked to keep within the general constraints of the grouping. This was in agreement with Tiffin & McCormick (1958, 215).

Results. The results of this forced distribution of the class according to a five-point scale are shown in Appendix H.

Rating Of Apprentices By Their Peers

In the endeavour to obtain a valid measure of the shop performance of this same group of fifteen apprentice automotive mechanics in the fourth-year in-school training course June-July 1971, an experiment of peer rating was made.

Method. The method of Thurstone's matched pairs was used for the peer rating. A rating form, similar to that shown in Appendix H was used. In order to protect the identity of the participants the names have been replaced by numbers. The rating form gave all the combinations of 15 persons taken two at a time for a total of 105 pairs. The participants were requested to choose the one person of the pair who they considered to be the better of the two in the shop situation.

The data on the rating forms were punched on to cards and, by the use of a computer programme developed by the Department of Vocational Education, University of Alberta, and the computer services of the University of Alberta, these data were transformed into z scores.

The z scores on the computer print-out were given a mean of fifty and a standard deviation of twenty as transformed scores.

Results. The transformed scores for the experiment together with the weighted performance scores as a criterion are shown in Appendix H.

The participants in the experiment made the remarks noted below on completion of the experiment: not a very good test; not very good; don't know the boys well enough; it is ninety-percent guess work; it is hard to decide; hard; its alright; its inaccurate; not much value; I don't know enough about them; we should work with the guys longer to know; its a poor method for school; might be good if we knew people better; not very accurate; hard and not very accurate; not accurate.

Rating Of Apprentices By The Shop Instructor

The shop mark for this same group of fourth-year automotive apprentices was obtained from the files of the Northern Alberta Institute of Technology during February 1972. It was believed that these marks were obtained and submitted in a routine manner, and were not influenced by this study in any way.

These marks were assessed by the instructor on the apprentice's ability, judgement and general success in the automotive shop at the Northern Alberta Institute of Technology. The marks are shown in Appendix H.

Rating Of Apprentices By The Provincial Apprenticeship Board

The marks obtained by this group of apprentices on the examination set, administered, and scored by the Provincial Apprenticeship Board, Alberta Department of Labour, were obtained from the files of the Northern Alberta Institute of Technology.

The marks are shown in Appendix H together with the criterion, the weighted performance rating of the apprentice.

Correlations

All the correlation coefficients used in this study were obtained using the computer facilities of the Northern Alberta Institute of Technology, and a programme developed by the Department of Student Counselling of that institution. The correlation matrix is shown in Appendix I.

THE APPRENTICE'S VIEW OF EXAMINATIONS

In order to obtain information from the apprentices to feed into the training system a survey of their views on the Apprenticeship Board examinations was made. From this survey it was expected that views on the applicability of the examinations, to the job which the apprentice does at his place of work, would be obtained. In this way it was expected that information on the validity of the questions would be obtained. This survey, it was considered, agreed with the ideas of feedback of Hunter et al (1969, 9).

The survey embraced four groups of apprentices who were

attending the Northern Alberta Institute of Technology. The survey requested their views on the Apprenticeship Board examinations that they had taken previously. Hence a second-year apprentice would be commenting on his experience with the first year examinations, and a third-year apprentice would be commenting upon his first and second years, etc.

The survey would have been of more value if it had been taken immediately after the apprentice had taken his examination. This was not done in this survey in order to keep the costs down to a reasonable figure, and to avoid requesting the Apprenticeship Board for the addresses of apprentices and by so doing increase the clerical burden in that office.

Method. Two instructors at the Northern Alberta Institute of Technology asked students in their classes if they were interested in writing their opinions of Apprenticeship Board examinations. On agreeing to give their written opinions the students were asked to respond to the question, "What is your opinion of the Apprenticeship Board exams you have written, in all aspects, regarding application to your trade?" The question and the responses are given in Appendix J.

Results.

1. Number responding: seventy-four
2. The number of respondents who question the validity of the examinations, or how well the questions relate to the job for which they are training: twenty-three, for thirty-one percent
3. The number of respondents who question the validity of the examination by re-

marking that it does not apply to the trade today: eighteen, for twenty-four percent.

4. The number of respondents who question the validity of the examination by remarking, or implying, that the questions are designed to trick those taking the examination: sixteen, for twenty-two percent.
5. The number of respondents who question the validity of the examination by remarking upon the difficulty encountered in reading the questions hence implying that another skill other than trade knowledge is being tested: sixteen, for twenty-two percent.
6. The number of respondents who question the validity of the examination by the implication, or definite statement, that there is a greater emphasis on mathematics than is necessary for the requirements of the trade: six, for eight percent.
7. The number of respondents whose responses indicate that they had a cultural difficulty with the examination: four, for five percent.

CHAPTER 5

ANALYSIS OF RESULTS

This Chapter has as its subject the analysis of results that have been derived in the study. However, the main thrust of the study has been the development of a model for the systematic training of apprentices for which there are no results. Subsidiary to the development of this training model studies were carried out on different aspects of apprenticeship in Alberta with the intention of demonstrating how, if this training model was used as the basis for apprenticeship training, the information derived would be handled in the training system.

This method was considered necessary because the training system would be staffed by people who would be carrying out the many functions of each of the subsystems: 1.0, Analyze Trade; 2.0 Establish Terminal Objectives; 3.0, Select Apprentices; 4.0, Develop Training Courses; 5.0, Implement Training; 6.0, Administer Results; 7.0, Monitor Effectivity of Training; 8.0, Conduct Experimental Courses also and not of least importance, communicating with each other and with the social environment. Thus the system would be in a state of flux and, so, untestable until set in motion.

Because of this the model will first be discussed, and following this discussion the different studies on apprenticeship training will be examined as though the model was in being as the system of training in Alberta.

THE MODEL

This training system for the development of tradesmen described pictorially and descriptively in Chapter 3 differs little from the model described in word-pictures by Tyler in his Basic Principles of Curriculum and Instruction: Syllabus for Education 305, which, he proposes, is suitable for the formal school. It also agrees with the proposals of Robert Stake of the Centre for Instructional Research and Curriculum Evaluation, University of Illinois, as set down in his The Countenance of Educational Evaluation, especially as seen in his summary. As a management tool the model with its requirements for measurable objectives and feedback mechanisms to permit the monitoring of the effectiveness of training programmes appears to agree with the evaluation system developed by Starr, and others, of The Centre for Vocational and Technical Education, Ohio State University, and described in their A System for State Evaluation of Vocational Education. Also within the model there are embedded ideas for systematic training that have been exposed in Chapter 2. The ideas for the systematic training of apprentices came from Germany, Great Britain and Ontario. Training on-the-job has been promoted by the Canadian Armed Forces and Britain's Engineering Training Board among others. The use of objectives in the developed model both for training course design and the evaluation of the trainees is congruent with the theses expressed by Gronlund, Mager, Troyer, as well as those involved with the many studies reported by the Human Resources Research Office, George Washington University. Thus, since it has been indicated that the model developed for this study is a synthesis of notions on train-

ing by a number of authorities in the discipline, and is in overall agreement with Tyler's views, it is suggested that the model, as developed, is workable and should result in improved and economical training of tradesmen.

AN EXAMINATION OF THE VALIDITY OF THE
TRAINING COURSE GIVEN TO FIRST-YEAR
APPRENTICE COOKS

This study would be done by subsystem 7.0, Monitor Effectivity of Training and it indicated that the school training given to this group of first-year apprentice cooks is approaching congruency with the needs of their particular jobs. The anomalous results obtained from some of the questions require further investigation.

A job analysis should be carried out by subsystem 1.0 to find out exactly what cooks actually do when they are working at their trades. It might be that second-year cooks do not do some of the tasks in which they received training in their first-year. (Note that the training is for first-year cook apprentices, but those who are successful at their examinations will move to the second-year of training. Thus this particular group will be responding from the work that they are actually doing as second-year apprentices).

It might be that the trade of baker overlaps the trade of cook to the extent that cooks do not become very involved with baking. Another reason for unsatisfactory responses to the questions that refer to baking might be that the large commercial bakeries are supplying the establishments at which these cooks work, at prices

against which cooks cannot compete. These questions would be provided with more reliable answers by an effective job analysis.

AN INDEPENDENT STUDY OF THE SECOND-YEAR
ELECTRONIC TECHNICIAN APPRENTICESHIP
BOARD EXAMINATION

According to subsystem 2.0 of the model, Establish Terminal Objectives, groups outside the training authority should be consulted on testing. This was such a consultation.

This examination in the opinion of the reviewing panel appeared, apart from the negative aspects that have been noted, to be reasonable. If it could be clearly demonstrated that the objectives of this period of apprenticeship are best measured, as being attained by the apprentice, by a written examination, then the negative aspects noted by the panel should be corrected. However, since no behavioral objectives for this training have been published by the Provincial Apprenticeship Board, and giving consideration to Foley's note that, "Although little research has been pursued regarding the use of traditional written examinations in lieu of performance test[s], the limited research available casts doubts on their validity" (Foley, 1963, 15), there is doubt that such a demonstration can be made. Hence this section may be summed up by saying that, the written examination is judged to be reasonable by the independent panel, but doubt must be cast on its validity to measure on-job performance in the absence of published behavioral objectives for the training that the examination purports to measure, and also on the lack of studies

correlating performance on a written examination to on-job performance.

This doubt may be set aside by a review of the examinations according to subsystems 1.0 and 2.0 of the model, which have the respective functions: Analyse Trade, Terminal Objectives.

A REVIEW OF THE PROVINCIAL APPRENTICESHIP
BOARD EXAMINATION FOR THE THIRD-YEAR
LEVEL PLUMBING APPRENTICE

This review would be carried out in subsystem 2.0, Monitor Effectivity of Training, by component 2.7, Validate Tests.

When statistical guides provided for the analysis of multiple-choice examinations by Wood and others (1968) were used to assess this examination, it was evident that improvements can be made to it. Furthermore, the examination was not based upon published behavioral objectives as would be expected for testing at the minimum essentials or training level (Gronlund, 1970, 33). Thus this examination should be reviewed.

It is supposed that this review would be carried out with reference to subsystems 1.0 and 2.0 of the model. This would require an analysis of the trade and the establishment of terminal objectives. The review according to subsystem 2.0 would shed light on the best type of examination to use for the demonstration of the desired behavior. It is possible that the review would indicate that the behaviors, following training, for such a trade as plumber are best measured by practical rather than written tests.

EVALUATION OF APPRENTICES BY SUPERVISORS

This study would be carried out as part of the validation function of 7.0, which is a subfunction of Monitoring the Effectivity of the Training. The actual study would be carried out by component 7.1.3, Monitor Operational Changes.

The rating technique used in this study has a feature that appears to be unique. This is the use of inspectors to discuss the apprentice's on-job performance with the apprentice's supervisor. From this discussion, in fact during the discussion, the inspector rated the apprentice.

This technique was used in an endeavour to obtain some sort of standard so that ratings could be compared. Tiffin and McCormick remark that ratings should be in terms, in a large undertaking, of the department which did the rating (Tiffin and McCormick, 1958, 230). That is, there cannot be equivalence of ratings even between departments of the same factory or business. Maier makes a similar point (Maier, 1965, 246). However, despite these views, if there was to be any degree of consistency in a score of on-job performance for apprentices working at different establishments, possibly at different jobs, and under different supervisors, the use of the technique used in this study was indicated.

The Pearson product-moment correlation between the ratings submitted by each of the two inspectors from entirely different interviews with the apprentices' supervisors is 0.846.

Colquhoun reported in her study of fifty-six graduate nurses who were rated by their supervisors: one a head nurse, the other an

assistant head nurse. In her study, since the nurses were in different hospitals, a number of different assessors were involved. The Pearson product-moment correlation varied between 0.09 to 0.52 (Colquhoun, 1967, 23). The technique used in this study has possibly overcome the disparity of ratings that confounded Colquhoun's survey.

EVALUATION OF THE WORK-SITUATION

This study is one of the tasks done in subsystem 3.0. The particular task is 3.6.2, Verifying Suitability of Employer.

The research that took place as part of this study did not uncover a quantitative evaluation of a workshop, or other place of work, in the role of a training institution. However, study has shown that in Europe before an employer may take an apprentice he must be able to satisfy the authorities that his establishment is suitable for the purpose (Présant, 1971; International Labour Office, 1966, 134).

The instrument developed for this study appears to give a reasonable evaluation of the work-situation, at least for the work-situation on which it was tested. The Pearson product-moment correlation between the evaluations carried out by two different inspectors is 0.522 which is significant at the 0.05 level. This coefficient, though, is considerably different than the close agreement at which these same two inspectors arrived in the rating of the apprentices by their supervisors.

One can only conjecture the reason for this difference in the two correlation coefficients. One reason might be that the super-

visors of the establishments were less objective in discussing the place for which they were responsible than in discussing the abilities of the apprentice. Inspector A noted after completing the survey that "the supervisors 'caught on' after a while that their 'place' was also being rated". Thus the last inspector to go to one of the establishments may have been having a discussion with a 'wise' supervisor. Another reason for the discrepancy might result from the tendency of inspector B to rate the work-situation closer to the mean. It is noted that in the rating of the apprentices, the ratings of inspector A had a standard deviation of 10.1 and inspector B had a standard deviation of 11.0, but in the rating of the work-situation inspector A had a standard deviation in his rating of 12.4 whereas inspector B had a standard deviation in his rating of 9.9.

This evaluation of the work-situation indicated that for the establishments assessed in this study there is little difference between the average workshop in an urban situation and the average workshop in the rural situation, when both are assessed as training establishments. Considering the average workshop, this conclusion is not in agreement with Broad and his committee who considered that training in rural establishments was inferior to training in urban establishments (1970, 9).

The evaluation of the work-situation does show that there is a large variation among workshops, in the ability of these shops to give breadth of experience to the apprentices who work in them.

These data might suggest that those workshops with a pooled evaluation, on the instrument used in this study for the evaluation

of the work-situation, below sixty do not offer sufficient breadth of training to employ apprentices.

WEIGHTED PERFORMANCE OF APPRENTICES

The score, that here is called the weighted performance of apprentices, was developed in this study in an endeavour to obtain a score that may be used as a criterion. Thus other scores can be compared with this criterion score.

If apprenticeship training is off-job training, as much of it is in Alberta today, and the measure of the apprentice's ability to perform on-the-job is by a written test of the off-job training, then it appears necessary, as Foley has pointed out (1962, 7), to conduct studies on the correlation between the written test score and the on-job performance score of the apprentice. This was such a study.

According to Tiffin and McCormick performance ratings are heavily loaded with a factor that they call "the ability to do the present job" (1958, 225). Hence it appears reasonable to use a performance rating as a measure of on-job performance, although the use of a rating for this purpose is deplored by Wilson who suggests that only on-job performance tests are useful (Wilson, Foley, 1963, 4). However, since an on-job performance test was not able to be assessed during this study it was necessary to fall back upon the rating with the notion that it was loaded with a job performance factor. Furthermore, there is another aspect to the question of rating versus an on-job performance test, that is the fact that regardless how well a person is able to do his job he is still working with people. Hence

their views on his work performance could be important as Neff points out (1968, 125). The implication here is that on-job performance is not the same as the ability to do the task.

The pooled rating of the apprentice by his supervisor, which Tiffin and McCormick point out is more reliable than individual ratings (1958, 244), was multiplied by the pooled assessment of the work-situation. In this way it is proposed that differences in the standards required by different supervisors (Tiffin and McCormick, 1958, 22) have been overcome to some extent.

THE CORRELATION MATRIX

An examination of the Correlation Matrix shows that Apprenticeship Board examinations do not correlate very well with mean apprentice performance, nor do they correlate well with the weighted performance of the apprentices which is the criterion measure of this study. This low correlation was interpreted as indicating that what is desirable performance on an Apprenticeship Board examination is not necessarily a desirable performance on the job.

All the correlations with the weighted performance except the Apprenticeship Board examination were found to be significant at the five per-cent level.

This result gives support to modern practices in training that have been cited in this study. These practices may be summarized by saying that the only valid test for on-job performance is a test that takes place on-the-job.

This information would be fed back to subsystem 2.0, Establish

Terminal Objectives, for the information of those people who are involved with the development of tests and examinations in the training system.

THE APPRENTICES' VIEWS OF EXAMINATIONS

The remarks made by apprentices about the Apprenticeship Board examinations tend to agree with the conclusion of Brim and others that a positive attitude will only be held by the test taker if he believes that the test results will reflect his ability (Brim et al, 1969, 97).

There might be evidence in these remarks that the validity of examinations set for apprentices could be questioned on legal grounds as Hasler (1972, 12) has pointed out. Fred Whittle, Director of the Provincial Apprenticeship Board, has noted that there is a possibility of Government responsibility in the event of an examination error (Edmonton Journal, May 26, 1972).

There is another possibility that might be examined, that is, the apparent cultural difficulties that some apprentices encounter. This possibility has been the concern of Kirkpatrick et al in their Testing and Fair Employment. They say that instances may be expected where tests will differ in validity in different cultural groups, and may discriminate unfairly among them (1968, 36). Possibly this facet also has legal implications.

It is suggested that testing according to behavioral objectives would overcome the negative features of the examinations about which these apprentices have remarked. The development of tests according

to behavioral objectives is a function of subsystem 2.0 of the model. Further to this, this subsystem 2.5 of the model has provision for the consultation of concerned groups. The apprentices themselves should be consulted as a concerned group.

CHAPTER 6

SUMMARY AND CONCLUSIONS

SUMMARY

The purpose of this study was to develop a model for apprenticeship training. This purpose has been fulfilled.

This model is a modification of a general training model. The modification that was carried out takes care of the differences between apprenticeship training that calls for training in a sequence of blocks or modules, that could satisfy the apprentice's personal needs as well as the needs of his particular job, and a one shot training course for which the model was originally designed.

The different blocks of training that are necessary to bring the apprentice from the trade knowledge that he might possess at the commencement of his training to the experienced worker standard of a journeyman tradesman are developed from an analysis of the job that tradesmen in his particular trade actually do. Such an analysis, and the development of training course material from it, would solve two often stated problems of apprentice training: little recognition is given to changing skills that are used on the job, and the use of obsolete training syllabuses. The model provides for the use of follow-up procedures to ensure that all groups involved with the training are satisfied that training suitable for the job and trade in question has actually been carried out.

The model, then, is job-centred. As a job-centred model, the different training needs of employers, whose job requirements for

workers in the same trade are probably different, is taken into account. This is possible because the employer himself is made responsible for the on-job phase of the training. In order to combat what could, and often does, result in poor quality training, the model makes provision for a quality control function.

The quality control of training embraces such matters as test development and test supervision, different methods of surveying the results of training and testing in order that the training system, as a whole, is functioning as it was designed and also to improve training. The findings of this action are fed back into the system in such a way that it can adjust itself to changing demands of the job, of the trade, and of the world of work as a whole.

The complaint that apprenticeship training, in general, has a poor liaison with formal education has been given attention in this model. In fact provision has been made for liaison with all concerned groups wherever they are and whoever they be.

The model, as has been noted, was developed from a general training model. It is a synthesis of a number of established training notions that are in use in Europe, and it is in agreement with the thinking of a number of pre-eminent scholars in the field of education in North America. Because of these reasons, the model is considered to be sound.

The use of the training model as developed in this study may encourage the industrial sector of this Province to take an active rather than a passive role in the training of the manpower that is necessary for their growth, indeed their very survival. They may be

encouraged to be participants in, rather than spectators of, the training of apprentices. This model gives the employers responsibility for the on-job training of their workers.

The off-job training, that analysis indicates as being necessary, is presumed to be that part of job theory that is necessary to a skilled tradesman, but which is easier taught in a classroom setting than in the workshop. This part of the training should have behavioral objectives that are measurable in off-job situations, otherwise the training should take place on the job-site itself.

The job-centred model developed in this study, then, is a synthesis of progressive apprenticeship training schemes that have been developed elsewhere. The model makes use of behavioral objectives for both on and off-job training. In an endeavour to ensure that the required standard of training is both attained and maintained, a quality control function is built into the model. This quality control is a monitoring function with channels for the forward and backward flow of information to improve the different aspects of training. The model also makes use of concerned groups who may be either inside or outside the training itself. All of which, studies indicate, is in agreement with the best thinking in education today.

CONCLUSIONS

It is concluded that the training of apprentices can be systematic. Such training would use contemporary notions of educational theory, but would be job-centred.

This job-centred training would return some of the respons-

ibility for apprentice training to the employer. Thus the model has some measure of agreement with traditional forms of apprenticeship.

The function of the training authority, the Provincial Apprenticeship Board in Alberta, would be that of quality control. This would ensure that only those employers who could give their apprentices sufficient breadth of experience would be permitted to engage apprentices. It would also ensure that the standards of apprenticeship training would be set, and maintained, at a standard that was sufficiently high for the economic well-being of the Province and also for the social mobility of the tradesmen.

The information derived from the search of the literature that was part of this study is that such a scheme of systematic apprenticeship would tend to reduce the costs of apprenticeship training, and develop tradesmen who, at the very least, would be the equal to those prepared by the present training methods.

RECOMMENDATIONS FOR FURTHER STUDY

A study of the Bemtel Foundation's method of assessing and scoring practical examinations is a necessary further step in instituting a scheme of systematic apprenticeship. It is recommended that as part of such a study the researcher or researchers pay a visit to the Bemtel Foundation, Holland, to view and discuss the designing as well as the method of scoring these examinations. This visit should also continue on to the United Kingdom, where, it appears, the Bemtel method has received wider application than in Holland. This study could also develop the Bemtel method into areas of practical

work in which it does not appear to be used as yet, but where preliminary work carried out during this present study indicates that it might have an application.

Studies have been carried out in the United States (Foley, 1965) that indicate that some off-job training is given from the wrong point of view. It is postulated that it is such studies that caused the Canadian Armed Forces to abandon the traditional method of off-job training in favour of performance oriented training, POT, and performance oriented electronics training, POET. It is recommended that a similar study be carried out to confirm that the training of technicians with skills at least equal to technicians given the traditional off-job training can be carried out in shorter time, with a lower attrition rate, and so at less cost than traditional training.

The benefits of subsidization of manpower training programmes is, according to Weisbrod (1969), a subject area where the facts have not been ascertained by hard research. Perhaps it would be beneficial to the Province to determine by a study if longtime economic benefits would accrue better by manpower training subsidies or by subsidies that would encourage secondary manufacturing industries to take up residence and who would train their own personnel.

Maurizi remarks that, "Becoming an apprentice is like making an investment - with the payoff increased earnings in the future" (1972, 201). He has developed a model that indicates that the payoff for non-whites in apprenticeship is significantly closer to the beginning of the apprenticeship than it is for white apprentices. A study to test these findings on native and Metis people in Alberta

would be most interesting and probably very useful to the manpower development of the Province.

BIBLIOGRAPHY

- Air Canada. Maintenance Department, Supervisor's Manual. Montreal: Author, no date.
- Air Training Command. Patterns of Technical Training A.T.C. Pamphlet 52-1. Randolph Air Force Base, Texas: Headquarters Training Command, United States Airforce, 1969.
- Alberta Gazette. Regulations with Respect to the Trade of an Electrician, July 31, 1969.
- Alberta Gazette. Regulations with Respect to the Trade of Machinist, July 15, 1967.
- Alberta Gazette. Provincial Apprenticeship Board Regulations Respecting the Trade of Motor Mechanic, July 31, 1965.
- Alberta Gazette. Régulations Governing the Trade of an Electrician, December 31, 1958.
- Alberta Gazette. Regulations Governing the Trade of a Motor Mechanic, March 15, 1964.
- Anand, V.P. "A Descriptive Report on the Need, Objective and Development of Aptitude Test Prepared by the Directorate General of Employment and Training for Recruitment in Selected Trades at the Industrial Training Institutes in the Country." New Delhi: Ministry of Labour, Employment and Rehabilitation, No date. (mimeographed)
- Anastasi, A. Psychological Testing, 2nd Ed. New York: Macmillan, 1961.
- Anco. (Food, Drink & Tobacco Industry), Training Grants and Levy Schemes, 1971/72. Dublin: The Industrial Training Authority, 1970.
- Angus, R., (Alberta) Limited. Heavy Duty Mechanic Apprenticeship, Edmonton: Author, no date.
- Ashton, T.S. The Industrial Revolution, 1760 - 1830, A Galaxy Book. New York: Oxford, 1964.
- Belbin, R.M. The Discovery Method: An International Experiment in Retraining. Paris: O.E.C.D., 1969.
- Bemetal. The Hague, Holland: Bemetal Foundation, no date.
- Berufsbildungsgesetz (BBIG). Bonn, 1971.
- Best, W.H. "Some New Directions in Personnel Appraisal", in Karn, H.W., and Von Haller Gilmer, B., Eds., Reading in Industrial and Business Psychology, 2nd. Ed. New York: McGraw-Hill, 1962.

- Braun, R.A. Personnel Assistant, Giddings and Lewis Machine Tool Company, Wisconsin, Private Letter, April, 1970.
- Breer, P.E., and Locke, E.A. Task Experience as a Source of Attitudes, Homewood, Ill.: Dorsey, 1965.
- Brim, O.G., Glass, D.C., Nevlinger, F., and Firestone, I.J. American Beliefs and Attitudes About Intelligence, New York: Russel Sage Foundation, 1969.
- Broad, T.W., Price, D., Thompson, A.J., Smith, R.C., Breadner, B. and Donahue, R. A Brief to the Commission on Educational Planning, Edmonton: Civil Service Association of Alberta, 1970.
- Bruner, J.S. The Process of Education, First Vintage Ed. New York: Random House, 1963.
- Butts, R.F. A Cultural History of Western Education, 2nd Ed. New York: McGraw-Hill, 1955.
- Canada Department of Labour. "Labour Legislation in 1970-71, Part I: Apprenticeship and Tradesmen's Qualifications", The Labour Gazette, (72, 2).
- Canadian Forces. Course Training Standard for Electrician, Level 3. Ottawa: Canadian Forces Headquarters, 1969.
- Canadian Forces. Training System Manual, CFP 9000. Ottawa: Canadian Forces Headquarters, 1969.
- Cattel, R.B., and Butcher, H.J., The Prediction of Achievement and Creativity. Indianapolis: Bobs-Merril, 1968.
- Colquhoun, D.R. The Relationship Between Ontario Nurse Registration Examinations and Certain Criterion Measures, Doctoral Dissertation. Ann Arbor, Mich.: University Microfilm, 1967.
- Damm, H. "An Employer Looks at Training by Stages." Training for Progress, (19, 1-2).
- David, H.A. The Method of Paired Comparisons. London: Griffin, 1963.
- Dempsey, M. "Industrial Training for the Twentieth Century." Training for Progress, (9, 1).
- Department of Labour. Annual Report. Winnipeg, Man.: Department of Labour, Province of Manitoba, 1969.
- Downey, L.W. The Secondary Phase of Education. New York: Blaisdell, 1965.

- Dunnet, M.D. "Personnel Management" quoted by Maier, N.R.F. Psychology in Industry, 3rd. Ed. Boston: Houghton Mifflin, 1965.
- Dyck, H.J. Social Futures, Alberta 1970 - 2005. Edmonton: Human Resources Research Council, 1970.
- Editor. "Apprenticeship Reviewed". Training for Progress. (5, 1).
- Editor. "External Examinations Incompatible with Goals of Education", A.T.A. Magazine. May-June 1971.
- Edmonton Journal. Gov't mistake causes 100 to rewrite exam. May 26, 1971.
- Engineering Industry Training Board. The Analysis and Training of Certain Engineering Craft Occupations. Watford, Herts.: Author, 1971.
- Engineering Industry Training Board. Modules Welding Practices: Group F Modules. Watford, Herts.: Author, 1968.
- Entwurf einer Ausbildungsordnung fu die "maschenwarenproduzierende Industrie". Bonn: no date.
- Fitts, P.M. "Factors in Complex Skill Training" in Glaser, R., Ed., Training Research and Education. Pittsburg: University of Pittsburg, 1962.
- Fleishman, E.A. "The Description and Prediction of Perceptual - Motor Skill Learning" in Glaser, R., Ed. Training Research and Education. Pittsburg: University of Pittsburg, 1962.
- Foley, J.P. Jr. Functional Fundamentals Training for Electronic Maintenance Personnel. Wright-Patterson AFB, Ohio: Behavioral Sciences Laboratory Aerospace Medical Research Laboratories, 1965.
- Foley, J.P. Jr. Performance Testing: Testing for What is Real. Washington: National Technical Information Service, 1963.
- Fowler, H.W., and Fowler, F.G. The Concise Oxford Dictionary of Current English. New Edition, Oxford: Clarendon, 1929.
- Francis, W.N. The Structure of American English. New York: Ronald, 1958.
- Friedman, G. Industrial Society. New York: Free Press, 1955.
- Gagné, R.M. ed. Psychological Principles in System Development. New York: Holt, Rinehart and Winston, 1962.

- Gagné, R.M. and Fleishman, E.A. Psychology and Human Performance. New York: Holt, 1959.
- Getzels, J.W., Lipham, J.M. and Campbell, R.F. Educational Administration as a Social Process. New York: Harper and Row, 1968.
- Ginsberg, E. and The Conservation of Human Resources Staff, Columbia University. Manpower Strategy for the Metropolis. New York: Columbia University, 1968.
- Ginsberg, E. The Ineffective Soldier, Lessons for Management and the Nation: The Lost Divisions. New York: Columbia University, 1959.
- Glaser, R., Ed. Training Research and Education. Pittsburg: University of Pittsburg, 1962.
- Griffiths, D.E. "The Nature and Meaning of Theory", in Griffiths, D.E., Ed. Behavioral Science and Educational Administration, The Sixty-third Yearbook of the American Society for the Study of Education, Part II. Chicago: N.S.S.E., 1964.
- Gronlund, N.W. Stating Behavioral Objectives for Classroom Instruction. Toronto: Collier-MacMillan, 1970.
- Guyton, A.C. Textbook of Medical Physiology. 4th Ed. Philadelphia: Saunders, 1971.
- Halden, R. "Six Months of SAF Training Activity", Training for Progress. (10, 1-2).
- Hammer, G.G. The Relation of Trade and Industrial School Education to Apprenticeship Training. Ed. D. Dissertation, University of Missouri, 1950.
- Harris, D. and Mackie, R.R. Factors Influencing the Use of Practical Performance Tests in the Navy. Washington: Clearinghouse, 1962.
- Hasler, K.R. "Importance of Descriptive Validity in Psychological Measurement". Personnel Journal, (51. 1).
- Haywood, H.W. Chief of Motive Power and Rolling Stock, C.P. Rail, Montreal, Private Letter. February, 1971.
- Hilgard, E., and Atkinson, R.C. Introduction to Psychology, 5th. Ed. New York: Harcourt, Brace & World, 1964.
- Hill, J.E., and Kerber, E. Models, Methods and Analytical Procedures in Educational Research. Detroit: Wayne State University, 1967.

- Hills, N. "Plenty of Jobs Gov't Study Shows", Edmonton Journal.
Dec. 16, 1971.
- Hills, R.J. The Concept of System. Eugene, Ore.: University of
Oregon, 1967.
- Holding, D.H. Principles of Training, First Edition with Corrections.
London: Pergamon, 1969.
- Hoxie, R.F. Scientific Management and Labour. New York: Appleton,
1918.
- Hunter, H.G., Lyons, J.D., MacCaslin, E.F., Smith, R.G. Jr., and
Wagner, H. The Process of Developing and Improving Course Content
for Military Technical Training. Alexandria, Va.: George
Washington University, Human Resources Research Office, 1969.
- Hutchinson, J.G. Managing a Fair Day's Work. Ann Arbor, Mich.:
University of Michigan, 1963.
- International Brotherhood of Electrical Workers. Standards of
Apprenticeship and Training for Television Technicians,
RCA/IBEW. Washington: Author, 1970.
- International Labour Office. Construction Skills. Genève, Switzerland:
CIRF, 1969.
- International Labour Office. European Apprenticeship. Genève,
Switzerland; CIRF, 1966.
- Johnson, R.W. A Second Look at the Drop-out Problem in Apprenticeship
Training. Fredericton, N.B.: New Brunswick Department of
Labour, 1968.
- Johnson, R.W. Some Dimensions of the Drop-out Problem in Apprenticeship
Training. Fredericton, N.B.: New Brunswick Department of
Labour, 1967.
- Kerlinger, F.N. Foundations of Behavioral Research. New York: Holt,
Rinehart and Winston, 1964.
- Kirkpatrick, J.J., Ewen, R.B., Barrett, R.S. and Katzell, R.A.
Testing and Fair Employment. New York: New York University
Press, 1968.
- Krause, E. "Training by Stages". Training for Progress, (9. 1).
- Kuhn, A. Labour: Institutions and Economics. New York: Harcourt,
Brace and World, 1967.
- Lewis, W.A. The Theory of Economical Growth. Homewood, Ill.:
Irwin, 1955.

- Lockheed-California Company. Lockheed Apprenticeship Program, 1969 Information Bulletin - 3rd Quarter. Burbank, Cal.: Author, 1969.
- Logan, H.G. Trade Unions in Canada. Toronto: MacMillan, 1948.
- Lonsdale, R.C. "Maintaining the Organization in Dynamic Equilibrium", in Griffiths, D.E., Ed. Behavioral Science and Educational Administration, The Sixty-Third Yearbook of the National Society for the Study of Education, Part II. Chicago: N.S.S.E., 1964.
- Lynton, R.P., and Pareek, U. Training for Development. Homewood, Ill.: Irwin, 1967.
- McInnis, C.E. The Development of a Common Selection and Classification Battery - Men for the Canadian Forces. Toronto: Personnel Applied Research Unit, 1968.
- McKeon, J.C. "Training Records and Information Systems". Training and Development Handbook, Craig, R.L., and Bittel, L.R., eds. New York: McGraw-Hill, 1967.
- Mager, R.F. Preparing Objectives for Programmed Instruction. San Francisco: Fearon, 1962.
- Maier, N.R.F. Psychology in Industry, 3rd Ed. Boston: Houghton Mifflin, 1965.
- Main, W.L. Manager Apprenticeship Training, Chrysler Institute, Chrysler Corporation, Michigan, Private Letter, March, 1971.
- Maurizi, A. "Minority Membership in Apprenticeship Programs in the Construction Trades". Industrial and Labour Relations Review, (25, 2) January, 1972.
- Mayhood, J.E., Ph. D., Deputy Chief of Staff, Management and Research, Training Command Headquarters, Canadian Forces Base Winnipeg, Manitoba, Private Letter, May, 1971.
- Mergen, B. "Blacksmiths and Welders Identity and Phenomenal Change". Industrial and Labour Relations Review, (25, 3), March, 1972.
- Metcalfe, F. "Modular Training for Engineering Craftsmen". Training for Progress, (9, 1).
- Metis Association of Alberta. "Brief to Congress on the Future of Education", Edmonton, 1970 (Mimeographed).
- Miller, R.B. "Analysis and Specification of Behavior for Training", in Glaser, R., Ed. Training Research and Education, Pittsburg: University of Pittsburg, 1962.

- Miller, B. "The Newer Roles of the Industrial Psychologist", in Von Haller Gilmer, B., Ed. Industrial Psychology. New York: McGraw-Hill, 1961.
- Moran, J.E. "Taking Training Out to the Trainee." Training for Progress. (9. 1).
- Morrison, R.T., and Boyd, R.N. Organic Chemistry, 2nd Ed. Boston: Allyn and Bacon, 1966.
- Nadler, L. "Training Explained". Industrial Training International, (6. 4).
- National Advisory Council on Education for Industry and Commerce, Report of the Committee on Technician Courses and Examinations. London: Stationery Office, 1969.
- National Joint Apprenticeship and Training Committee for the Electrical Industry, Procedure for Selection of Apprentices for the Electrical Contracting Industry. Washington: Author, 1963.
- National Joint Apprenticeship and Training Committee for the Electrical Industry, Local Apprenticeship and Training Standards for the Electrical Industry. Washington: Author, no date.
- Navy Civilian Personnel Instructions, NCPI 410. Washington: United States Navy, no date.
- Neff, W.S. Work and Human Behavior. New York: Atherton, 1968.
- Neilson, W.A., Ed. Webster's New International Dictionary of the English Language, 2nd Ed. Springfield, Mass.: Meriam, 1934.
- Northern Alberta Institute of Technology. NAIT Calendar 1970. Edmonton: Alberta Department of Education, 1970.
- Okamoto, H. "Vocational Training in Japan", in Japan Labour Bulletin, January, 1970.
- Ontario Department of Labour. Block 155 Issue 3. Toronto: Author, 1970.
- Otis, J.L., and Leukart, R.H. Job Evaluation, 2nd Ed. New York: Prentice-Hall, 1956.
- Patton, J.A., and Littlefield, C.L. Job Evaluation. Homewood, Ill.: Irwin, 1957.
- Personnel Administration Office, Employee Performance Rating Form, PAO-5. Edmonton: Province of Alberta, Author, no date.

- Personnel Development Centre. Level of Attainment Training.
Cincinnati, Ohio: Cincinnati Milacron, no date.
- Phelps-Brown, E.H. The Economics of Labour. New Haven: Yale, 1962.
- Pieper, W.J., Foley, J.D., Jr., and Valverde, H.H. Learner-Centered Instruction (LCI): Volume VI -- Course Methodology and Administration. Wright-Patterson AFB, Ohio: Air Force Human Resources Laboratory, Air Force Systems Command, 1969.
- Popham, W.J., and Husek, T.R. "Implications of Criterion-Referenced Measurement", Journal of Educational Measurement. (6, 1).
- Porter, E.H. Manpower Development: The System Training Concept.
New York: Harper and Row, 1964.
- Présant, E.J., Attaché, Canadian Embassy, Brussels, Private Letter,
June, 1971.
- Professional Engineers in Industry. Evaluating Engineering Performance, 2nd Ed. Washington, D.C.: National Society of Professional Engineers, 1965.
- Provincial Apprenticeship Board. Apprenticeship Newsletter, August.
Edmonton: Alberta Department of Labour, 1970a.
- Provincial Apprenticeship Board. Trade Training, Is Apprenticeship for You? Edmonton: Alberta Department of Labour, 1970b.
- Provincial Apprenticeship Board. Apprenticeship Newsletter, August.
Edmonton: Department of Labour, 1969b.
- Provincial Apprenticeship Board. Course Outline for Apprentice Electricians. Edmonton: Alberta Department of Labour, 1969a.
- Provincial Apprenticeship Board. Course Outline for Cook Apprentices.
Edmonton: Alberta Department of Labour, 1968.
- Provincial Apprenticeship Board. Course Outline for Radio Technician Apprentices. Edmonton: Alberta Department of Labour, 1967.
- Remmers, H.H., and Gage, N.L. Educational Measurement and Education,
Revised Edition. New York: Harper and Brothers, 1955.
- Restle, F. "The Relevance of Mathematical Models for Education",
in Hilgard, E.R., Ed. Theories of Learning and Instruction,
The Sixty-Third Yearbook of the National Society for the Study of Education, Part I. Chicago: N.S.S.E., 1964.
- Ridgeway, C. "Individual Differences and Training Effectiveness",
Industrial Training International, (6, 6).

- Road Transport Industry Training Board. Practical Testing, Vehicle Trades Apprentice. London: Author, no date (mimeographed).
- Roff, H.E., and Watson, T.E. Job Analysis. London: Institute of Personnel Management, 1961.
- Rokeach, M. The Open and Closed Mind. New York; Basic Books, 1960.
- Rose, G.R., Ph. D. Private Letter. October 18, 1971.
- Rozenhart, W.L., Personnel Administrator, R. Angus (Alberta) Limited, Edmonton, Private Letter, November, 1971.
- Saylor, J.G. and Alexander, W.M. Curriculum Planning for Modern Schools. New York: Holt, Rinehart and Winston, 1966.
- School Act, Revised Statutes of Alberta, 329, 1970.
- Seashore, S.E., Indik, B.P., and Georgopoulos, B.S. "Relationships among Criteria of Job Performance", in Karn, H.W., and Von Haller Gilmer, B., Eds., Readings in Industrial and Business Psychology, 2nd Ed. New York: McGraw-Hill, 1962.
- Seymour, W.D. Industrial Skills. London: Pitman, 1966.
- Shartle, C.L. "Job Analysis" in Fryer, D.H., and Heury, E.R., Eds. Handbook of Applied Psychology. New York: Rinehart, 1950.
- Siegel, A.I., Schultz, D.G., Fischl, M.A. and Lanterman, R.S. "Absolute Scaling of Job Performance". Journal of Applied Psychology. (52, 4).
- Singer, E.J., and MacDonald, I.D. Is Apprenticeship Outdated? London: Institute of Personnel Management, 1970.
- Skinner, B.F. The Technology of Teaching. New York: Appleton-Century-Crofts, 1968.
- Skinner, B.F. Science and Human Behavior. New York: MacMillan, 1963.
- Smith, A. The Wealth of Nations, 2nd Ed., Vol. 1. London: Methuen, 1920.
- Smith, M.B., Bruner, J.S., and White, R.W. Opinions and Personality. New York: Wiley, 1956.
- Smith, R.G., Jr. The Engineering of Educational and Training Systems. Lexington, Mass.: Heath, 1971.

- Smith, R.G., Jr. The Design of Instructional Systems. Alexandria, Va.: George Washington University, Human Resources Research Office, 1966.
- Smith, R.G., Jr. The Development of Training Objectives. Washington: George Washington University, Human Resources Research Office, 1964.
- Stake, B.E. The Countenance of Educational Evaluation. Urbana: University of Illinois, Center for Instructional Research and Curriculum Evaluation, no date (mimeographed).
- Starr, H., Dieffenderfer, R.A., Archer, B.B. and Ernst, M. A System for State Evaluation of Vocational Education. Columbus, Ohio: The Center for Vocational and Technical Education, Ohio State University, 1970.
- State Labour Office. Vocational Training for Adults in the Netherlands. The Hague: Ministry of Social Affairs and Public Health, 1964.
- Stewart, D. Education Malpractices. Westminster, Cal.: State Services, 1971.
- Streeter, B.L. Fluid Mechanics. New York: McGraw-Hill, 1962.
- Super, D.E. The Psychology of Careers. New York: Harper and Brothers, 1957.
- Super, D.E., and Crites, J.O. Appraising Vocational Fitness By Means of Psychological Tests, Revised Edition. New York: Harper and Row, 1949.
- Thomas, D.B. "A General Model for Training Course Design", Royal Air Force Education Bulletin, No. 7, Autumn, 1970.
- Thorndike, R.L., and Hagen, E. Measurement and Evaluation in Psychology and Education. New York: Wiley, 1969.
- Tiffin, J. "Six Merit Rating Systems", in Karn, H.W., and Von Haller Gilmer, B., Eds. Readings in Industrial and Business Psychology, 2nd Ed. New York: McGraw-Hill, 1962.
- Tiffin, J., and McCormick, E.J. Industrial Psychology, 3rd. Ed. London: Allen and Unwin, 1966.
- Tiffin, J., and McCormick, E.J. Industrial Psychology, 4th. Ed. Englewood Cliffs, N.J.: Prentice-Hall, 1958.
- Tradesmen's Qualifications Act, Revised Statutes of Alberta, 367, 1942.

- Troyer, D.L. "Formulating Performance Objectives", in Weigand, J., Ed. Developing Teacher Competencies. Englewood Cliffs, N.J.: Prentice-Hall, 1971.
- Tyler, R.L. Basic Principles of Curriculum and Instruction: Syllabus for Education 305. Chicago: University of Chicago, 1950.
- United States Navy, Study of Apprenticeship and Skills Training. Washington: Navy Department, 1967.
- Van Dalen, D.B. Understanding Educational Research, Revised Ed. New York: McGraw-Hill, 1966.
- Walsh, G. Industrialization and Society. Toronto: McClelland and Stewart, 1969.
- Wass, S., Assistant Manager -- Manpower Services, Canada Manpower Centre, Edmonton, Private Letter, December, 1971.
- Watson, J.D. The Double Helix. New York: Atheneum, 1968.
- Weisbrod, B.A. "Benefits of Manpower Programs: Theoretical and Methodological Issues", in Somers, G.G., and Wood, W.D., Eds. Cost-Benefit Analysis of Manpower Policies. Kingston, Ont.: Industrial Relations Centre, Queen's University, 1969.
- Wellens, J. The Training Revolution. London: Evans, 1963.
- Whitehead, A.N. An Introduction to Mathematics. A Galaxy Book. New York: Oxford, 1958.
- Whittle, F.E. Apprenticeship News Letter, August. Edmonton: Alberta Department of Labour, 1970.
- Wilkinson, B.W. Studies in the Economics of Education. Ottawa: Queen's Printer, 1966.
- Wolffle, D. "Training" in Stevens, S.S., Ed. Handbook of Experimental Psychology. New York: Wiley, 1951.
- Wood, J.A., Allers, R.A., Hornsby, J.A., Radcliffe, L., Westbury, R., and White, S.A. Statistical Supplement to Summary Description of Grade Nine Literature Objectives, Test Items and Blueprint, 1st. Ed. Edmonton: Department of Education, 1968.
- Ziegler, W.L. The Future of Education: Who Speaks for Mankind? Paper presented at the Congress of the Future: Education, Dec. 3 - 5, 1970 Edmonton. Sponsored jointly by the Human Resources Research Council and the Commission on Educational Planning.

APPENDIX A
INFORMATION FROM THE
CANADIAN FORCES

This Appendix contains information on training that was obtained from a briefing on training at Headquarters, Training Command, Canadian Forces Base, Winnipeg, Westwin, Manitoba.

The pertinent information obtained from this briefing is reproduced in point form below:

1. Formal training courses were getting out of hand; they were getting longer and longer.
2. Under the present scheme, nothing goes into a training course unless a significant number of the field units indicate that it is necessary.
3. The notion of training adopted by the Canadian Forces is Performance Oriented Training (POT).
4. The old training courses over trained. That is, there was much material taught that was never used.
5. The Canadian Forces consider that they now have systematic training. This they say is a realistic approach to training.
6. Performance on the job is the criterion.
7. Much of the training in the Canadian Forces is hands-on training. That is training on actual jobs.
8. There were impressive results when Performance Oriented Training was applied to the various electronic trades.
9. Extraneous, irrelevant theory has been cut out of Performance Oriented Electronics Training, (POET), as it has been from other training.
10. There is a lot of the theory that is of no use to the practicing

tradesmen in the field.

11. The cutting out of irrelevant material from the training courses has reduced boredom.
12. The Job Oriented Training has resulted in increased motivation.
13. As a result of the previous two items, the attrition rate during training has materially decreased.
14. Another benefit from Performance Oriented Training is reduced training costs.
15. The new concept of training provided a better or at least an equally qualified tradesman to the tradesmen trained by means of the old 'traditional' training courses.
16. The necessary theory is taught by programmed texts and keeps pace with the practical training.
17. The old traditional training courses were failing twenty to twenty-five percent of the trainees. Performance oriented training fails approximately five percent.
18. Assessment of the student is on pass or fail. That is, can he do the job or can he not do the job.
19. The battle is now between the student and the training standard, not between student and student.
20. The Canadian Forces have been greatly influenced by R.F. Mager's writings which might be summed up as, "what does the learner have to know to do this task".
21. When the Canadian Forces started to write their own learning programmes, the programme writers influenced everyone when they asked, "what are the objectives of this particular course".

22. The training was developed as follows:
 - a) Analyse job.
 - b) Ask man in field, what he actually does.
 - c) Observe tradesmen while they are working at their jobs.
 - d) Make a judgement of future requirements of the trade.
23. The Canadian Forces have developed trade specifications which give the duties, knowledge, skill and techniques required for each level of the trade.
24. The analysis for each trade was carried out by a team of three or four practicing tradesmen and one officer. The analysis took approximately one year for each trade.
25. Tasks are assembled into:
 - a) course training standard
 - b) on-job training standard
26. A training standards team (one for each trade) produce objectives for each task.
27. There are objectives for every pay level in each trade.
28. There is a course on training standards writing at the Canadian Forces School of Instructional Techniques.
29. There is a training standard on training standards writing.
30. The introduction to a trade is usually by a training course.
31. Threshold tests were developed to find the level of each trainee before placing him in the training course.
32. The training concept got rid of mathematics as such.
33. The Canadian Forces have been influenced a great deal by the studies carried out by the Human Resources Research Organization,

Alexandria, Virginia.

34. The Canadian Forces teach to the examination, or, putting it another way, they teach to the objectives of the course, and only the objectives are tested.
35. The Canadian Forces like multiple choice tests for those who can do the job but cannot write about it.
36. Training narrowly, as in the Canadian Forces, does not, they believe, detract from improvising or other problem-solving abilities. The older type courses were no better at teaching improvising than the new narrow training.
37. For low-level trainees, validation questionnaires are directed to the immediate supervisor of the graduate.
38. For higher level graduates, the validation questionnaires are directed to the graduates themselves.
39. The training programmes must continually be validated.
40. The Canadian Forces say that they do not know a lot about the attitudes of trainees and graduates.

APPENDIX B**A SURVEY OF FIRST-YEAR COOK APPRENTICES**

This survey was undertaken for the purpose of obtaining some indication of the validity of the training of this group in particular; however, the more general purpose was a demonstration of the use of a mailed survey of apprentices in order to obtain their impressions of the quality and usefulness of the material to which the apprentices were exposed.

This Appendix contains the survey questionnaire, a letter that accompanied the questionnaire, and the tabulated results of the survey.

First Year Apprentice Cooks

Student Feedback on Training Course Content

You probably received instruction in the following areas of your trade during your period at the Technical Institute.

Please place a check (✓) in just one of the columns under question A and another check (✓) in just one of the columns under question B.

Please be sure to answer all parts of both questions.

	Question A Was your first year training adequate for this task? (Check one)		Question B How often do you perform this task? (Check one)	
	YES	NO	Often	Sometimes
Use & care of equipment				
Weights & measures				
Portion control				
Use of leftovers				
Sanitary food handling				

		NO	YES	NEVER	SOMETIMES	OFTEN
Vegetable	cleaning & preparation					
	cooking					
Meat & poultry	roasting					
	stewing & braising					
	broiling & grilling					
	deep frying					
Fish cookery						
Meats	grades & classification					
	retail & wholesale cuts					
	identification & uses of various cuts					
Pastry goods	pie pastry & fillings					
	basic cake making					
	puff pastry					
	quick breads					
	choux paste & meringues					
	yeast goods					
Hot sauces	white					
	brown					
	velouté					
	tomato					
	hollandais					
Soups						
Stocks						
Salads	side salads					
	cold plates					
	dressings					
	basic sandwich fillings					
	basic sandwich preparation					
Beverage making						
Arithmetic						
General knowledge						

Street,
Edmonton, Alberta
September 10, 1971

Dear

I am conducting a study of apprenticeship training that is sponsored by the Alberta Human Resources Research Council.

One part of this study is to obtain opinions from apprentices on how useful they have found the material that they were taught in their courses at the Technical Institute. The questionnaire that is attached is designed to obtain your opinion on this matter.

Please be assured that any information that you provide will not be given to the Apprenticeship Board, nor will any of your instructors be informed of your opinions of the material that you were taught.

This questionnaire will not affect your marks in anyway, nor will it affect your position with the Apprenticeship Board or the Technical Institute.

If you wish to add something about the course that the questionnaire does not permit, please feel free to write on the back of the form.

I will be very grateful if you would assist in this study by returning the questionnaire in the stamped addressed envelope not later than September 24, 1971.

Attached is a dollar bill as a token payment for your time and effort in assisting with this project.

If you would be interested in obtaining a summary of the opinions of the apprentices, please put a slip of paper in the envelope with your name on it.

In the event that you do not wish to answer the questionnaire please return it in the envelope provided.

Thank you for your assistance.

Yours truly,

T.W. Broad

Table B - 1

Selection of Alternative Responses to the Question
 "How Often Do You Perform This Task"
 by First - Year Apprentice Cooks

Question	Response Alternatives		
	Often	Sometimes	Never
Use and care of equipment	11	0	0
Weights and measures	6	3	2
Portion control	8	3	0
Use of leftovers	6	4	1
Sanitary food handling	10	1	0
Vegetable cleaning and preparation	8	3	0
Vegetable cooking	9	2	0
Meat and poultry roasting	9	2	0
Meat and poultry stewing and braising	9	2	0
Meat and poultry broiling & grilling	8	3	0
Meat and poultry deep frying	6	4	1
Fish cookery	3	5	3
Meat, grade and classification	6	4	1
Meat, retail and wholesale cuts	5	5	1
Meat, identification and uses of cuts	5	4	2
Pie pastry and fillings	5	4	2
Basic cake making	6	0	5
Puff pastry	3	5	3

Table B - 1 (continued)

Question	Response Alternatives		
	Often	Sometimes	Never
Quick breads	3	2	6
Choux paste and meringues	4	2	5
Yeast goods	4	2	5
Hot sauce, white	7	3	1
Hot sauce, brown	8	2	1
Hot sauce, velouté	8	2	1
Hot sauce, tomato	7	2	2
Hot sauce, hollandais	7	3	1
Soups	6	3	2
Stocks	5	2	4
Side salads	7	3	1
Cold plates	6	5	0
Salad dressings	5	6	0
Basic sandwich fillings	6	2	3
Basic sandwich preparation	4	5	2
Beverage making	0	3	8
Arithmetic	1	9	1
General Knowledge	5	5	1

Table B - 2

**Selection of Alternative Responses to the Question "Was Your
First - Year Training Adequate for this Task"
by First - Year Apprentice Cooks**

Question	Response Alternatives	
	Yes	No
Use and care of equipment	11	0
Weights and measures	10	1
Portion control	10	1
Use of leftovers	9	2
Sanitary food handling	11	0
Vegetable cleaning and preparation	10	1
Vegetable cooking	10	1
Meat and poultry roasting	11	0
Meat and poultry stewing and braising	11	0
Meat and poultry broiling and grilling	9	2
Meat and poultry deep frying	8	3
Fish cookery	9	2
Meats, grades and classification	9	2
Meats, retail and wholesale cuts	10	1
Meats, identification and uses of cuts	8	3
Pie pastry and fillings	10	1
Basic cake making	8	3
Puff pastry	11	0

Table B - 2 (continued)

Question	Response Alternatives	
	Yes	No
Quick breads	8	3
Choux paste and meringues	8	3
Yeast goods	10	1
Hot sauce, white	10	1
Hot sauce, brown	11	0
Hot sauce, velouté	11	0
Hot sauce, tomato	11	0
Hot sauce, hollandais	10	1
Soups	10	1
Stocks	9	2
Side salads	10	1
Cold plates	11	0
Salad dressings	10	1
Basic sandwich fillings	9	2
Basic sandwich preparation	9	2
Beverage making	5	6
Arithmetic	10	1
General knowledge	10	1

APPENDIX C

AN INDEPENDENT REVIEW OF THE EXAMINATION FOR SECOND-
YEAR RADIO-T.V. APPRENTICES

In order to obtain an independent view of this examination in particular, but to demonstrate a more general procedure, a review board composed of individuals unconnected with this study in any other way was convened.

The review board was presented with the Instructions and Criteria for a Validity Assessment of a Written Examination in an Apprenticeship Trade, the Examination Question Validity Assessment List, and the Question Distribution List, all of which are shown here. Also arrangements were made for them to review the examination.

The distribution of the examination questions, according to the review board's view, is shown here also. In actuality the review board placed the particular question numbers in the box. In order to maintain the security of the test, the question numbers have been omitted. Where there are no considerations of security the question numbers should remain in the box for the enlightenment of the test makers who should examine a review board's findings and take them into consideration in recasting the examination.

Instructions and Criteria for a Validity Assessment of a Written Examination in an Apprenticeship Trade

List the examination questions that do not satisfy the criteria below by circling S or U, whichever is appropriate, on the Validity Assessment List provided.

1. The examination questions should be limited to material in the published curriculum for the particular trade.
2. Each question should be clear and unambiguous.
3. If the questions are of a problem solving type it should be possible to obtain one and only one answer and this answer should agree with the answer key. For questions of other types the possible answers should be acceptable to a person knowledgeable in the trade and the answer key should indicate the various answers possible.
4. The questions should not depend upon other abilities, such as reading ability, or knowledge, other than trade knowledge, for a successful response.
5. The questions should be couched in terms that are both applicable and acceptable to the trade in question.
6. The questions should reflect current trade practices, that is they should be up-to-date.
7. After discussing the content of each question place the question number in the relevant box of the attached Question Distribution List according to the opinion of the panel.

Examination Question Validity Assessment List

Instructions, circle S or U, whichever is appropriate, pertaining to the question number and the criteria number as listed in the Instructions and Criteria for a Validity Assessment of a Written Examination in an Apprenticeship trade.

Q	<u>Criteria</u>					
	1	2	3	4	5	6
1	S U	S U	S U	S U	S U	S U
2	S U	S U	S U	S U	S U	S U
3	S U	S U	S U	S U	S U	S U
4	S U	S U	S U	S U	S U	S U
5	S U	S U	S U	S U	S U	S U
6	S U	S U	S U	S U	S U	S U
7	S U	S U	S U	S U	S U	S U
8	S U	S U	S U	S U	S U	S U
9	S U	S U	S U	S U	S U	S U
10	S U	S U	S U	S U	S U	S U
11	S U	S U	S U	S U	S U	S U
12	S U	S U	S U	S U	S U	S U
13	S U	S U	S U	S U	S U	S U
14	S U	S U	S U	S U	S U	S U
15	S U	S U	S U	S U	S U	S U
16	S U	S U	S U	S U	S U	S U
17	S U	S U	S U	S U	S U	S U
18	S U	S U	S U	S U	S U	S U
19	S U	S U	S U	S U	S U	S U
20	S U	S U	S U	S U	S U	S U
21	S U	S U	S U	S U	S U	S U
22	S U	S U	S U	S U	S U	S U
23	S U	S U	S U	S U	S U	S U
24	S U	S U	S U	S U	S U	S U
25	S U	S U	S U	S U	S U	S U
26	S U	S U	S U	S U	S U	S U
27	S U	S U	S U	S U	S U	S U
28	S U	S U	S U	S U	S U	S U
29	S U	S U	S U	S U	S U	S U
30	S U	S U	S U	S U	S U	S U
31	S U	S U	S U	S U	S U	S U
32	S U	S U	S U	S U	S U	S U
33	S U	S U	S U	S U	S U	S U
34	S U	S U	S U	S U	S U	S U
35	S U	S U	S U	S U	S U	S U
36	S U	S U	S U	S U	S U	S U
37	S U	S U	S U	S U	S U	S U
38	S U	S U	S U	S U	S U	S U
39	S U	S U	S U	S U	S U	S U
40	S U	S U	S U	S U	S U	S U
41	S U	S U	S U	S U	S U	S U

Question Distribution List

Electron tube amplifiers	
Transistor amplifiers	
Audio circuits	
R.F.circuits	
Oscillators	
Principles of receivers	
Super-het. receivers	
Receiver circuits	
T.V. receivers	
Test instruments	
Radio receiver servicing	
Laboratory	
Mathematics	
Science	
Other	

Table C - 1

**Second-Year Radio-T.V. Technician Examination,
Distribution of Questions According
to Subject Division**

Subject Division	Number of Questions in Division
Electron tube amplifiers	9
Transistor amplifiers	10
Audio circuits	8
R.F. circuits	1
Oscillators	3
Principles of receivers	2
Super-het receivers	10
Receiver circuits	2
T.V. receivers	10
Test instruments	1
Radio receiver servicing	12
Laboratory	--
Mathematics	9
Science	12
Other	--
	89

There was a total of 83 questions on the examination.

One question was placed in four divisions.

Three questions were each placed into two divisions.

APPENDIX D**AN ITEM ANALYSIS OF THE EXAMINATION FOR
THIRD-YEAR PLUMBING APPRENTICES**

This Appendix shows the tabulated results of a conventional item analysis of multiple-choice questions. The analysis was carried out by computer methods.

TABLE D-1
THIRD YEAR EXAMINATION PLUMBER APPRENTICE
PLUMBING SECTION
ITEM ANALYSIS MULTIPLE CHOICE QUESTIONS

ITEM NUMBER	DIFFICULTY INDEX	BISERIAL CORRELATION	ITEM RELIABILITY INDEX	ITEM NUMBER	DIFFICULTY INDEX	BISERIAL CORRELATION	ITEM RELIABILITY INDEX	ITEM NUMBER	DIFFICULTY INDEX	BISERIAL CORRELATION	ITEM RELIABILITY INDEX
1	0.287	0.345	0.156	26	0.574	0.004	0.002	51	0.649	0.549	0.262
2	.851	.119	.042	27	.362	.395	.190	52	.915	.213	.059
3	.447	.369	.184	28	.543	.074	.037	53	.713	.267	.121
4	.755	.352	.151	29	.574	.058	.029	54	.809	.062	.024
5	.968	.161	.028	30	.564	.301	.149	55	.947	.246	.055
6	.915	.285	.079	31	.670	.232	.109	56	.255	-.054	-.024
7	.511	.380	.190	32	.766	.494	.209	57	.574	.074	.037
8	.755	.150	.065	33	.989	.048	.005	58	.819	.182	.070
9	.872	.149	.050	34	.436	.137	.068	59	.957	.499	.101
10	.447	.341	.169	35	.202	.037	.015	60	.979	.882	.127
11	.638	.414	.199	36	.894	.588	.181	61	.894	.162	.050
12	.894	.250	.077	37	.713	.100	.045	62	.787	.482	.197
13	.809	.312	.123	38	.330	.242	.114	63	.787	.281	.115
14	.660	.219	.104	39	.745	.313	.137	64	.723	.569	.255
15	.894	.148	.046	40	.691	.355	.164	65	.394	.549	.268
16	.723	-.096	-.043	41	.660	.243	.115	66	.553	.392	.195
17	.660	.460	.218	42	.340	.065	.031	67	.968	.057	.010
18	.243	.162	.070	43	.957	.485	.098	68	.872	.185	.062
19	.021	-.004	-.001	44	.596	.168	.082	69	.660	.518	.245
20	.340	.337	.159	45	.851	.397	.141	70	.796	.245	.099
21	.319	.231	.108	46	.660	.470	.223	71	.468	.401	.200
22	.596	.135	.066	47	.702	.528	.242	72	.787	.367	.150
23	.638	.262	.126	48	.809	.194	.076	73	.713	.515	.233
24	.606	.372	.182	49	.915	.189	.053	—	—	—	—
25	.585	-.024	-.012	50	.596	.219	.107	—	—	—	—

TABLE D-2
THIRD YEAR EXAMINATION PLUMBER APPRENTICE
GASFITTING SECTION
ITEM ANALYSIS MULTIPLE CHOICE QUESTIONS

ITEM NUMBER	DIFFICULTY INDEX	BISERIAL CORRELATION	ITEM RELIABILITY INDEX	ITEM NUMBER	DIFFICULTY INDEX	BISERIAL CORRELATION	ITEM RELIABILITY INDEX	ITEM NUMBER	DIFFICULTY INDEX	BISERIAL CORRELATION	ITEM RELIABILITY INDEX
1	0.774	0.154	0.064	10	0.602	0.158	0.777	19	0.849	0.242	0.087
2	.581	.363	.179	11	.774	.474	.198	20	.828	.380	.143
3	.473	.395	.197	12	.501	.217	.100	21	.828	.347	.131
4	.946	.413	.093	13	.903	.703	.208	22	.871	.226	.076
5	.839	.434	.159	14	.914	.598	.168	23	.570	.447	.221
6	.796	.320	.129	15	.828	.583	.220	24	.548	.378	.188
7	.430	.386	.191	16	.774	.409	.171	25	.237	-.024	-.010
8	.817	.294	.114	17	.796	.384	.155	26	.891	.508	.157
9	.699	.595	.273	18	.828	.049	.019	-	-	-	-

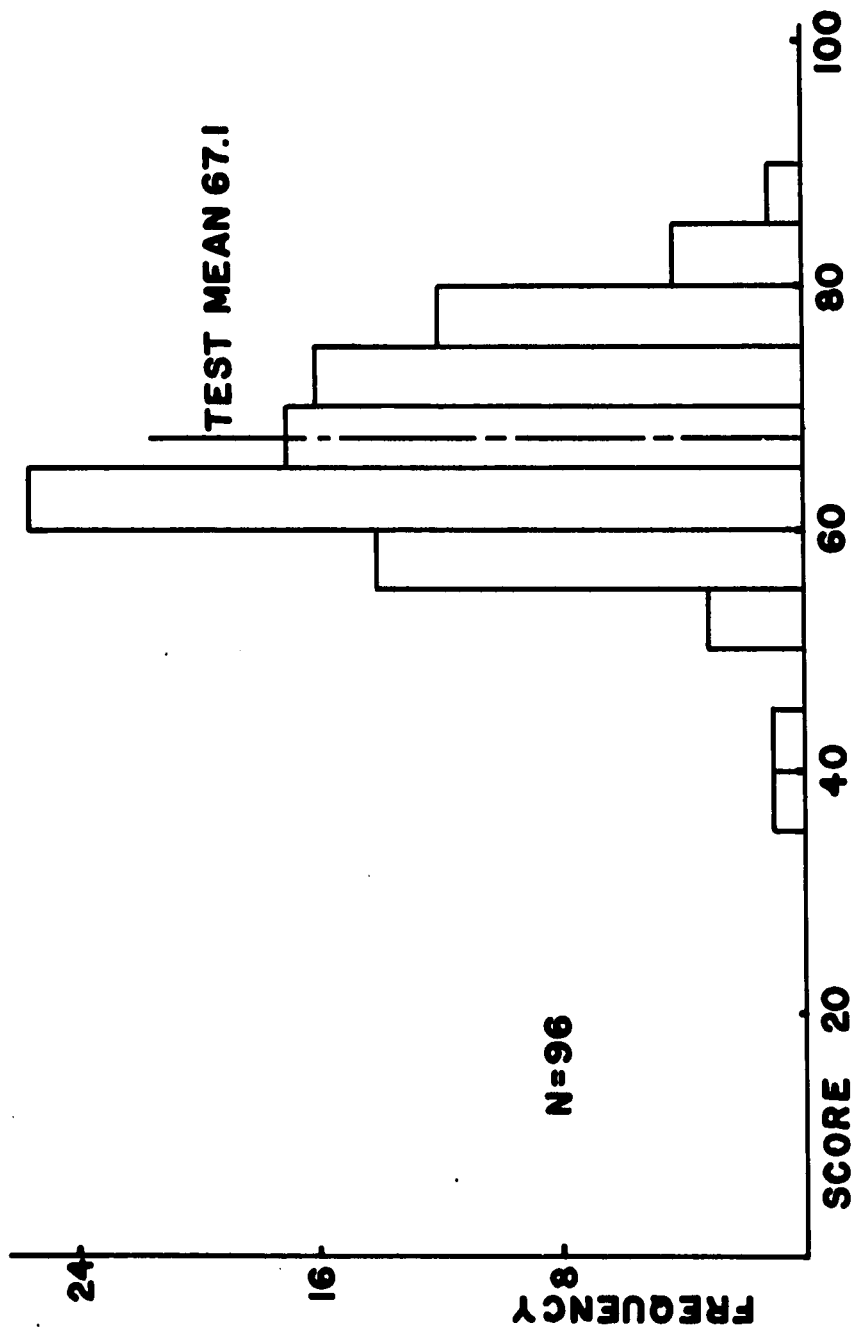

HISTOGRAM
THIRD YEAR PLUMBING APPRENTICES
TOTAL SCORE ON ALL TEST ITEMS
FIGURE D-1

APPENDIX E

THE EVALUATION OF APPRENTICES BY
SUPERVISORS

This part of the project commenced by obtaining permission from each apprentice in a class of fourth-year automotive mechanic apprentices who were taking the in-school part of their training at the Northern Alberta Institute of Technology.

After receiving this permission, each apprentice was requested to write his name, his supervisor's name, and the name and address of the establishment where he was employed on a slip prepared for this purpose. This slip is shown here.

The project continued by sending a letter to the supervisor named by the apprentice at the address listed. A typical letter is shown within.

The evaluation was conducted by two inspectors, independent of this study in any other way who were also independent of the Provincial Apprenticeship Board. Each of the inspectors was provided with a letter of introduction. This letter was general, but was directed to the recipients of the previous letter.

The evaluation instrument, Apprentice Performance Rating Form, was designed to be completed by the inspector during an interview with the apprentice's supervisor. This form is contained within.

The evaluation of each apprentice by his supervisor, as interpreted by each inspector is tabulated within. The identity of the apprentices involved has been made anonymous by the substitution of a number for his name.

APPRENTICE PERFORMANCE RATING FORM

APPRENTICE _____ TRADE _____

EMPLOYER _____ LENGTH OF EMPLOY _____
Months

INSPECTOR _____ DATE _____

This form is to be completed by the inspector during an interview with the apprentice's supervisor at the apprentice's place of work.

The rating scale varies from a low of 1 to a high of 10. The number which best describes the supervisor's judgement of the trait is to be circled.

- | | |
|--|-----------------------------|
| <p>1. <u>Production</u>
 Consider the amount of work he does, regardless of quality.</p> | <p>1 2 3 4 5 6 7 8 9 10</p> |
| <p>2. <u>Quality</u>
 Consider the quality of his work, regardless of quantity.</p> | <p>1 2 3 4 5 6 7 8 9 10</p> |
| <p>3. <u>Ability</u>
 Consider his ability from the point of view of what is expected from a person of his experience.</p> | <p>1 2 3 4 5 6 7 8 9 10</p> |
| <p>4. <u>Understanding</u>
 Consider his understanding of the theoretical aspects of his job.</p> | <p>1 2 3 4 5 6 7 8 9 10</p> |
| <p>5. <u>Safety</u>
 Consider the degree to which he follows correct safety practices.</p> | <p>1 2 3 4 5 6 7 8 9 10</p> |

- 6. Co-operativeness 1 2 3 4 5 6 7 8 9 10
Consider the way that he takes instructions and gets along with others.

- 7. Appearance 1 2 3 4 5 6 7 8 9 10
Consider personal cleanliness, tidiness, and appropriateness of his dress for the job.

- 8. Punctuality 1 2 3 4 5 6 7 8 9 10
Consider the punctuality of his starting and stopping work.

- 9. Record Keeping 1 2 3 4 5 6 7 8 9 10
Consider the way that he does the paper-work that is part of his job.

- 10. Initiative 1 2 3 4 5 6 7 8 9 10
Consider the degree that he can be relied upon to the extent of his experience and the amount of supervision required.

Performance rating _____

June 24th, 1971

Dear Mr.

I am making a study of apprenticeship training that is sponsored by the Alberta Human Resources Research Council.

One aspect that will be examined is on-the-job training. Another is the supervisor's view of a particular apprentice.

To get information on these factors, you will shortly be visited by two different people who will discuss them with you.

Although this work has the approval of the Provincial Apprenticeship Board, the persons who will visit you are not connected with the Apprenticeship Board in any way.

Let me emphasize that all information that you give to the interviewers will be treated as confidential, and in no way will the discussions affect the position of your apprentice with the Apprenticeship Board or with the Institute.

I will be very grateful for your assistance on this project, and for spending a little of your time with the interviewers.

Yours sincerely,

T.W. Broad.

c.c. Mr. F.E. Whittle
Director of Apprenticeship

APPRENTICESHIP PROJECT

Your Name.....

Your Supervisor's Name.....

Name of Firm.....

Address of Firm.....

.....

.....

Street,
Edmonton, Alberta
June 28th, 1971.

To whom it may concern:

This will introduce Mr.

Mr. is one of the interviewers mentioned in the letter that was sent to you regarding the study that is taking place on apprenticeship training.

It is hoped that you can spare a little of your time to discuss this matter with Mr.

Let me emphasize once more, that everything that you discuss with Mr. will be held in strict confidence, and that the discussions will not affect in any way, the progress of the apprentice.

I shall be very grateful for any assistance that you give to Mr. that will bring this project to a satisfactory conclusion.

Yours truly,

T.W. Broad.

TWB/sf

Table E - 1

**The Evaluation of Apprentices by
Their Supervisors**

App. No.	1	2	3	4	5	6	7	8	9	10	11	12	13	14	15
Insp. A	61	58	40	68	63	83	49	60	53	63	53	72	58	54	58
Insp. B	56	57	38	68	60	79	44	62	54	70	61	73	50	69	57
Mean Ev.	58	58	39	68	62	81	46	61	54	66	57	72	54	61	58

Inspector A: mean rating 59.5
 standard deviation 10.07

Inspector B: mean rating 59.9
 standard deviation 10.99

Mean Evaluation: mean rating 59.7
 standard deviation 10.07

Pearson's Product-Moment Correlation between
ratings by Inspectors A and B: 0.846

APPENDIX F

THE EVALUATION OF THE WORK SITUATION

This evaluation of the work situation, or, put differently, the apprentices' place of work regarded as a training institution, took place at the same time as the part of the project that involved the evaluation of the apprentices, and was conducted by the same two inspectors.

The tabulated results of this evaluation are shown within. The work situations for this particular part of the study were garages of different types. Tables give the characteristics of these garages, and the ratings of these garages under different characteristic headings.

It is believed that the instrument used for this evaluation, Work-Situation Rating Form, can be applied to all enterprises that employ tradesmen and purport to train apprentices. This form is provided within the Appendix.

WORK-SITUATION RATING FORM

EMPLOYER _____ BUSINESS TYPE _____

INSPECTOR _____ DATE _____

APPRENTICE _____ TRADE _____

This form is to be completed by the inspector during an interview with the apprentice's supervisor at the apprentice's place of work.

The rating scale varies from a low of 1 to a high of 10. The number which best describes the inspector's judgement of a particular factor is to be circled.

1. Amount of Time on Unskilled Work 1 2 3 4 5 6 7 8 9 10
 Consider jobs given to the apprentice that are unskilled or menial and do not contribute to his learning of the trade (percentage of time).
2. Rotation of Tasks 1 2 3 4 5 6 7 8 9 10
 Consider whether or not the apprentice is deliberately given different types of work in order to broaden his work experience.
3. Work with Journeyman 1 2 3 4 5 6 7 8 9 10
 Consider the amount of time that the apprentice spends working with a journeyman of his trade (percentage of time).
4. Direct Instruction 1 2 3 4 5 6 7 8 9 10
 Consider the amount of time given to the instructing of the apprentice on work that he has not previously encountered.

- 5. Breadth of Experience 1 2 3 4 5 6 7 8 9 10
 Consider the amount and variety of work done by the firm that could give a broad experience in his trade to the apprentice.

- 6. Interest of Journeymen 1 2 3 4 5 6 7 8 9 10
 Consider the encouragement given by the firm to journeymen to take an interest in apprentices.

- 7. Tools and Equipment 1 2 3 4 5 6 7 8 9 10
 Consider the amount of time spent teaching the apprentice the correct use of tools and equipment, consider both business and apprentice-owned tools and equipment where applicable.

- 8. Incentive Plans 1 2 3 4 5 6 7 8 9 10
 Consider the amount of time that the apprentice does NOT work under an incentive plan of some type.

- 9. Safety 1 2 3 4 5 6 7 8 9 10
 Consider the amount of time spent teaching the apprentice safe working practices.

- 10. Obligations to Apprentices 1 2 3 4 5 6 7 8 9 10
 Consider the degree to which the employer comprehends and carries out his obligations that are implicit in the Apprenticeship Act.

Work-situation rating _____

Table F - 1

The Evaluation of the
Work Situation

App. No.	1	2	3	4	5	6	7	8	9	10	11	12	13	14	15
Insp. A	81	74	59	69	55	74	73	79	83	42	79	82	54	64	58
Insp. B	77	50	65	61	58	65	72	71	65	55	87	61	51	72	62
Mean Ev.	79	62	62	65	56	70	72	75	74	48	83	72	52	68	60

Inspector A: mean rating 68.4
 standard deviation 12.44

Inspector B: mean rating 64.8
 standard deviation 9.90

Mean Evaluation: mean rating 66.5
 standard deviation 9.93

Pearson's Product-Moment Correlation between
ratings by Inspectors A and B: 0.522

Table F - 2

Garages Listed by Characteristics

Garage Type	Urban	Rural	Total
Automotive Dealership	4	--	4
General Garage	2	3	5
Local Garage	3	2	5
Speciality Garage	1	--	1
TOTAL	10	5	15

Table F - 3

Rating of Garages by Characteristics

Garage Type	Urban	Rural	Mean
Automotive Dealership	73	--	73
General Garage	68	65	66
Local Garage	62	70	65
Speciality Garage	48	--	48
Mean	66	67	66

Garages were rated as urban if the address was within the boundary of a large city.

Garages were rated to type by their names and by the class of business that was carried on at them.

APPENDIX G**CRITERION (THE WEIGHTED PERFORMANCE
OF APPRENTICES)**

What is considered to be a significant part of this study is an endeavour to develop a criterion measure of the on-job performance of apprentices.

This criterion, The Weighted Performance of Apprentices, attempts to develop this criterion from both the measure of apprentice on-job performance as seen by his supervisor and interpreted by the two inspectors, and the place of work of the apprentice when it is evaluated as a training organization.

This criterion measure is shown on a table in this Appendix.

Table G - 1

Criterion (Weighted Performance of Apprentices)

App. No:	1	2	3	4	5	6	7	8	9	10	11	12	13	14	15
Mean App. Rating	58	58	39	68	62	81	46	61	54	66	57	72	54	61	58
Mean Rating Work-Sit	79	62	62	65	56	70	72	75	74	48	83	72	52	68	60
Weighted Rating	46	36	24	44	35	57	33	46	40	32	47	52	28	41	35

Mean weighted rating: 39.7
Standard deviation 9.06

Mean Apprentice Rating from Table E - 1
Mean Rating Work-Situation from Table F - 1

The Weighted Rating or Criterion is the rounded product of the Mean Apprentice Rating and the Mean Rating Work-Situation.

APPENDIX H**THE RATING OF APPRENTICES BY FORCED-DISTRIBUTION, BY PAIRS, BY SHOP INSTRUCTORS' MARKS, AND BY APPRENTICESHIP BOARD MARKS**

The rating of job performance may be carried out in a number of ways. One of these, an actual test on a particular phase of the job or a particular task is an important measure of work performance; however this was beyond the resources of this particular part of the study to carry out.

The rating methods that were used in the project are conventional methods of evaluation. The method of paired comparisons required the apprentices in the group to rate themselves by selecting the better performer from a pair. The instrument used for this rating is not shown. In its place is a form similar in all respects except that the names were replaced by numbers.

The results of these ratings are provided in the two tables provided in this Appendix.

The Ability of Fourth-year Automotive Mechanics in a Practical Shop Situation.

Peer-rating by Method of Thurstone's Matched Pairs

Instructions: For each of the pairs of names, place a check mark (✓) by the name of the person who you believe to be the BETTER of the two in the SHOP.

Please **IGNORE** anything that you know about an individual's ability in **THEORY** classes.

Just check (✓) the name of the **BETTER** one of the two in **PRACTICAL** work in the **SHOP**.

- | | |
|----------|----------|
| 15 _____ | 02 _____ |
| 03 _____ | 07 _____ |
| 15 _____ | 09 _____ |
| 01 _____ | 08 _____ |
| 15 _____ | 11 _____ |
| 02 _____ | 07 _____ |
| 09 _____ | 03 _____ |
| 04 _____ | 11 _____ |
| 12 _____ | 10 _____ |
| 01 _____ | 04 _____ |
| 11 _____ | 10 _____ |
| 06 _____ | 13 _____ |
| 07 _____ | 01 _____ |
| 11 _____ | 14 _____ |
| 09 _____ | 02 _____ |
| 05 _____ | 12 _____ |
| 14 _____ | 06 _____ |
| 02 _____ | 08 _____ |
| 15 _____ | 04 _____ |
| 04 _____ | 12 _____ |
| 07 _____ | 04 _____ |
| 07 _____ | 15 _____ |
| 13 _____ | 05 _____ |
| 10 _____ | 07 _____ |
| 05 _____ | 06 _____ |
| 02 _____ | 06 _____ |
| 14 _____ | 08 _____ |
| 07 _____ | 12 _____ |
| 07 _____ | 05 _____ |
| 01 _____ | 05 _____ |
| 12 _____ | 01 _____ |
| 07 _____ | 13 _____ |
| 13 _____ | 09 _____ |

05 _____
09 _____
06 _____
05 _____
04 _____
13 _____
03 _____
15 _____
02 _____
14 _____
05 _____
14 _____
12 _____
03 _____
09 _____
06 _____
07 _____
03 _____
08 _____
01 _____
09 _____
06 _____
13 _____
02 _____
12 _____
08 _____
13 _____
14 _____
06 _____
10 _____
01 _____
11 _____
15 _____
03 _____
06 _____
13 _____
09 _____
01 _____
12 _____
04 _____
10 _____
02 _____
11 _____
06 _____
03 _____
05 _____
09 _____
02 _____
14 _____
12 _____
12 _____
08 _____
14 _____
11 _____

14 _____
01 _____
03 _____
08 _____
05 _____
04 _____
04 _____
01 _____
10 _____
04 _____
11 _____
09 _____
13 _____
02 _____
12 _____
15 _____
06 _____
08 _____
07 _____
10 _____
07 _____
12 _____
03 _____
12 _____
11 _____
15 _____
08 _____
02 _____
09 _____
03 _____
14 _____
03 _____
10 _____
14 _____
04 _____
14 _____
05 _____
11 _____
03 _____
08 _____
04 _____
11 _____
06 _____
08 _____
05 _____
15 _____
08 _____
13 _____
07 _____
15 _____
08 _____
10 _____
12 _____
13 _____

11 _____
06 _____
15 _____
02 _____
06 _____
10 _____
10 _____
02 _____
15 _____
01 _____
15 _____
02 _____
03 _____
08 _____
09 _____
09 _____
10 _____
10 _____

07 _____
10 _____
03 _____
05 _____
01 _____
14 _____
09 _____
04 _____
13 _____
13 _____
14 _____
01 _____
01 _____
11 _____
04 _____
11 _____
05 _____
13 _____

Table H - 1

**Shop Instructors' Rating of Apprentices
by Forced-Distribution Method**

App. No.	1	2	3	4	5	6	7	8	9	10	11	12	13	14	15
Inst. X	2	3	1	3	4	5	3	3	4	5	4	3	2	2	3
Inst. Y	3	2	1	3	5	5	3	4	4	3	4	3	2	2	3
Mean Rating	25	25	10	30	45	50	30	35	40	40	40	30	20	20	30

Mean of Mean Rating: 31.3

Standard deviation of Mean Rating 10.60

The Mean Rating is the average of the ratings by Instructors X and Y multiplied by ten.

Pearson's Product-Moment Correlation between ratings by Instructors X and Y: 0.774

Table H - 2

**Rating of Apprentices by Their Peers, the Marks Given by
Shop Instructors and the Mark Obtained by Each
Apprentice on the Apprenticeship Board
Examination**

App. No.	1	2	3	4	5	6	7	8	9	10	11	12	13	14	15
Peer Rating	34	60	22	36	56	94	34	54	90	46	64	42	34	32	54
Shop Mark	71	73	63	76	82	87	74	77	81	80	80	78	68	72	79
App.Bd.Mark	83	79	74	84	88	85	77	75	93	82	88	85	79	79	90
Criterion	46	36	24	44	35	57	33	46	40	32	47	52	28	41	35

Mean PEER RATING: 50.1
Standard Deviation 20.79

Mean SHOP MARK: 76.1
Standard Deviation 3.13

Mean APPRENTICESHIP BOARD MARK: 82.7
Standard Deviation 5.59

The PEER RATING was obtained by the method of paired-comparisons.

The SHOP MARK was the mark given to each apprentice by the shop instructors for the shop portion of the in-school training.

The APPRENTICESHIP BOARD MARK is the work assigned to each apprentice by the Provincial Apprenticeship Board for the examination results set by and scored by the Board on completion of the apprentices' in-school training.

APPENDIX I**CONSOLIDATED TABLE AND CORRELATION
MATRIX**

Gathered together here are the scores given or obtained by this group of fourth-year automotive mechanic apprentices that have been provided in Appendices E, G, and H. thus providing an overview of all pertinent scores.

Also provided is the correlation matrix of these scores. This matrix indicates also significance of these correlations at the usual 0.01 and 0.05 levels of significance.

Table I - 1

Consolidated Table of Ratings and Marks

App. No.	1	2	3	4	5	6	7	8	9	10	11	12	13	14	15	Mean
Criterion	46	36	24	44	35	57	33	46	40	32	47	52	28	41	35	39.7
Mean Evaluation	58	58	39	68	62	81	46	61	54	66	57	72	54	61	58	59.7
Mean Forced-Dist.	25	25	10	30	45	50	30	35	40	40	40	30	20	20	30	31.3
Peer Rating	34	60	22	36	56	94	34	54	90	46	64	42	34	32	54	50.1
Shop Mark	71	73	63	76	82	87	74	77	81	80	80	78	68	72	79	76.1
App. Bd. Mark	83	79	74	84	88	85	77	75	93	82	88	85	79	79	90	82.7

The CRITERION is the weighted Performance of Apprentices from Table G - 1.

The MEAN EVALUATION is from Table E - 1.

The MEAN FORCED-DISTRIBUTION is the Mean Rating from Table H - 1.

The PEER RATING, SHOP MARK and APPRENTICESHIP BOARD MARK are all from Table H - 2.

Table 1 - 2

Correlation Matrix of Ratings and Marks

	Mean App. Evaluation	Mean Forced-Dist.	Peer Rating	Shop Mark	App. Bd. Mark
CRITERION (Weighted Performance of App.)	0.761*	0.528**	0.492**	0.604*	0.341
Mean Apprentice Evaluation	-----	0.617*	0.451**	0.708*	0.356
Mean Forced- Distribution	-----	-----	0.783*	0.960*	0.603*
Peer Rating	-----	-----	-----	0.796*	0.617*
Shop Mark	-----	-----	-----	-----	0.684*

* Correlation significant at the 0.01 level.

**Correlation significant at the 0.05 level.

APPENDIX J**THE APPRENTICES' VIEWS OF
EXAMINATIONS**

This part of the project was an endeavour to assess the validity of examinations from an examination of the views that apprentices hold about the examinations that they have written.

A copy of the question sheet that was presented to each apprentice that took part in this segment of the project is enclosed in this Appendix. The apprentices' responses to the questions are also contained here.

Apprenticeship Study

DO NOT PUT YOUR NAME ON THIS PAPER

Please express your opinions freely in answering the following question.

What is your opinion of the Apprenticeship Board exams you have written in all aspects regarding application to your trade?

APPRENTICES' RESPONSES

A. Second Year Instrument Mechanics

- 1) I feel it is a very good exam but if it included more solution of problems it would have been much better than a multiple choice.
-

- 2) 1. To much waiting to get marks returned.
 2. The exam itself shouldn't count 100%, school work should count some.
 3. Multiple choice questions aren't always the fairest.
 4. Exams should be reviewed or changed somewhat.
-

- 3) 1. One question comes to my mind is "Name 4 ways to break a hack-saw blade." Questions of this nature are ridiculous.
 2. Math and physics questions were okay.
 3. I felt that more D.C. theory could be taken in place of practical pipe fitting (ect.). This would take the load off the 2nd. year electronics theory, and make the 1st. year a little more challenging.
-

- 4) I think the exam should not be taken as a cut and dried case, your final pass mark should in 50% school mark and 50% Apprenticeship.

We are usually pretty up tight for the last exam because our livelihood depends on whether we pass it or not. Therefore the answers should be clear and not a trick type answer if multiple choice.

- 5) 1. Questions - some similar except for wording.
2. Some material was definitely not covered during school term.
-

- 6) Too much importance placed on whether this exam is passed or not - no school work is regarded as far as the Apprenticeship Board is concerned.
-

7) First Year Inst. Apprentice Exam

In my opinion the first year exam was too highly marked with mathematics. I grant that math is extremely important but I also feel that it is only a related subject towards instrumentation and that more emphasis should be placed on instrumentation itself.

Thank You

- 8) The Board exam should not decide our final mark. The Board Exam should be about 50% of your final mark and the other 40% coming from your work in school.
-

- 9) I felt that the first year exam did not relate closely enough to the day to day requirements of the trade involved and that too high a percentage of the exam was basically mathematics. The length of time required to get the marks back was also too long.
-

- 10) I believe some multiple choice questions are misleading and are there only to confuse you. Plus there are always about two questions on subjects which weren't on the curriculum.
-

B. Second Year Radio-T.V. Mechanics

- 1) The only thing that I see wrong is that the course is quite foreign to the work carried out in the trade. Lab is geared mostly to radio this year while we study television in theory [classes] . This discrepancy should not be. Also first year should be updated. Perhaps 2nd. yr. becomes 1st. year, 3rd. year - 2nd. year, 4th. year perhaps something more uptodate.

- 2) I think that the exams are a little out of date but seem to be improving. As far as being too hard or too easy, they seem to be about right, with the emphasis on keeping and letting only the people who know the trade into that trade. Personally I think that they are a very good idea but I would like to see them kept up to date slightly better. They are extremely nessessary.

- 3) The exams were in line with the trade but their way of question- ing was as if they [were] out to trick you, not to find out how much you [had] learned.

- 4) Exams are slightly outdated although the mark results can generally indicate a good tradesmen.
[?] Why! The exam can indicate his logical thinking ability, which is most important in any trade.

- 5) The exams apply to the trade as it was several years ago. Also most of the work is practical but most of the exams deal largely with theory. The school and the apprenticeship board do

not seem to work together too closely.

Once you receive your journeyman status you keep it for life, regardless of changes in the industry. There should be an upgrading system following the final exam to renew your license periodically.

- 6) 1. The Apprenticeship Board exams are rather tricky. Some of the questions are deceiving.
2. It seems [that] if you know the theory you can pass the exam but no exam is given on bench work.
3. Some persons know their work but cannot put it down on paper.
-

- 7) I find that the Apprentice Board does very good and fine work. For the past years I have gained much knowledge. The exams are right in with the study and training. Although a thorough understanding of the trade no-one will get.
-

- 8) Exams are too conventional. Questions are not very clearly stated, often misleading, and not straight forward. Most of the exams are extremely old and do not apply to modern technology, [they] should definitely be brought up to date.

Also teaching staff should have greater knowledge of material asked on questionnaire [in order] to adjust and concentrate themselves more on the material in question.

- 9) The exams used to date seem to be outdated. The problems use old circuits which have not been in practice for 20 years. The course is fairly good for answering the exam questions, but a lot of material

is useless. For to get good tradesmen the instructors must teach [both the] old and [the] new, and most of it is new. Thereby giving a student a poorer mark on the exam which does not usually effect how good a technician he is. Overall, the exam is good in theory only, when it comes to applying what was asked or learned, it is not so simple for some.

- 10) The exams are very out of date. The wording of the questions is very confusing. Some of the questions are more in the field of designing and not servicing.
-

- 11)
1. Most of the questions are too hard to understand.
 2. Out of date
 3. Should have more questions ask about the repair problems.
 4. Most of the questions on the exam doesn't [or are not] required on the service [ing of equipment]
-

- 12) In servicing the exam is not as practical as it could be and the exams do not match teaching at school. I do not feel passing the exam with a good mark makes a good service technician.
-

- 13) I feel the exams are not up to date and apply more to the designers than it does to repairmen.
-

- 14) 1. Don't apply to course subject as much as they could.

2. Don't give a good indication of what one does know about the course.

3. Some questions are very far out, not applying to the real situation, which they could since practical knowledge is needed on the course.

-
- 15) 1. There should have been more questions on the principles and applications of transistors.
2. The multiple choice questions could have been worded a little more clearly.

16) Questions are hard to understand.

17) Probably necessary for some amount of quality control and assures better tradesmen. Exams probably could be kept more up-to-date if more qualified personnel made up the exams, instructors etc. rather than tradesmen.

The courses themselves do up-grade trademen and are a big help.

C. Third Year Welding Apprentices

1) For the amount of material covered in six weeks the exams are too complicated.

2) Most questions covered the trade good enough except for some of the math questions.

Example, for finding different volumes or areas of certain vessels the formulas were not correctly shown.

- 3) Blueprint reading and science complicated.
-
- 4) Exam was easy, probably not drawing the best effort from students. May not hurt the trade but will not contribute to upgrading standards. May in the future lead to low rating for tradesmen.
-
- 5) Some of the words are too hard to understand.
-
- 6) Please don't use high English words, I hope you understand what you [are] asking.
-
- 7) I have never written an apprenticeship exam 1st. or 2nd.
-
- 8) Good exam it covered everything taken.
-
- 9) Some questions are unfair, there are many poor pictures given.
-
- 10) At was very hart
Special for people from Europa.
-
- 11) The exams for first and second years were about average to understand.
-

- 12) Je trouve que c'est trop de questions pour la simple raison que dans fauter les usines que nous allons travailler, nous n'avons pas le privilège de choisir la rod à souder que nous voulons au ferron la bonne.

Ca fera surement de bon et ecriture

[Translation: I find that there are too many questions for the simple reason that in the shops where we work we do not have the chance of picking the rod that we like to weld our best. That would surely make for the best in writing.]

- 13) Trop de mathematic dans l'examen.

[Translation: Too much mathematics in the examination.]

- 14) There should be more questions on the trade part of it. Most of the older people in our trade don't fully understand the math part of it. We never use anything more than basic math anyway. Since I've been in the trade I have never had to do any more than add a few fractions.

- 15) Haven't written any apprenticeship Board exams before.

- 16) The Apprenticeship Board should express more on drawing details showing the actual size or picture of the object or objects being referred too.

- 17) The exams cover more than what your notes do, and some of the questions are hard to understand.

- 18) Many of the multiple choice questions could have been answered with more than one of the answers with more than one.
-

- 19) Too many questions on multiple choice, one gets weary about half way through the test.
-

- 20) There is too much math on the exams.
There are too many questions that are not on the trade.
-

- 21) No problem with the exception of math, for people that have been out of school for a number of years, this is a problem.
-

- 22) Questions are hard to understand other than that they were alright.
-

- 23) [I] only took the 2nd year exam. It seemed to cover welding fairly well [but it] was hard.
-

D. Fourth-year Apprentice Automotive Mechanics

- 1) I feel that a great many questions don't apply to the trade today. The exams should be updated.

I basically disagree with examinations in the automotive field as they are a poor way of testing one's affinity and qualification to this trade.

- 2) Some [questions] are hard to understand.
Most exams are out dated.
-
- 3) Complicated some question wrong english
-
- 4) The exams are too tricky and they have too many un-understand-
able words in them pertaining to the trade at hand.
-
- 5) The questions are stupid, the people that make them up should
take a course in English language because the wording on most
questions are for a child.
-
- 6) Half the questions are not worthwhile.
-
- 7) The apprenticeship exams are written down too tricky, you
know the answer but the question is all backwards.
-
- 8) They do not try to see what you know, they try to trick you
on the question.
-
- 9) Fourth year should not be review.
-
- 10) The exams are not too bad for first 3 years but fourth year
don't get enough questions on automatics and you should get [a]
majority [of the questions] on automatics.
-

- 11) I think they are too outdated.
-
- 12) They should be more up-to-date. Otherwise they are a good exam except some of the questions are hard to understand what they are asking for.
-
- 13) The examination should have more straight forward questions. The examination should be more up-to-date.
-
- 14) The exam is good in most aspects but poor in others. 1st. year on tools is overdone. They should put more questions pertaining to overhaul and quit trying to trick everyone.
-
- 15) In regard to the Apprenticeship Board exams, I think the questions are good but they used too many different words which have the same meaning. But the word we have to use is the word they figure is best, but sometimes we were taught by a different word.
-
- 16) Some of the questions have no bearing on [the] trade when we leave [the technical training] school.
-
- 17) 1. Questions are poorly worded.
2. Other than that okay.
-
- 18) They are okay (but they should stop putting in so many trick questions).
-

- 19) They do not pertain to what was taught in class, [and] not enough stress put on practical experience.
-
- 20) They should be up-dated and deal with more modern machinery.
-
- 21) No comments
-
- 22) Some questions on exams are outdated. Questions are often misleading and not really a benefit to the student.
-
- 23) They are good questions but the way they are worded is more in testing your reading than what you know [about the job].
-
- 24) Some questions are related to obsolete equipment.
-