

26757



National Library of Canada

Bibliothèque nationale du Canada

CANADIAN THESES ON MICROFICHE

THÈSES CANADIENNES SUR MICROFICHE

NAME OF AUTHOR / NOM DE L'AUTEUR CHARLES GORMACK GATES

TITLE OF THESIS / TITRE DE LA THÈSE Aspects of the Environment - Lungworm (Nematoda: Metastrongyloidea) - Bighorn sheep (Civis c. canadensis) System

UNIVERSITY / UNIVERSITÉ University of Alberta

DEGREE FOR WHICH THESIS WAS PRESENTED / GRADE POUR LEQUEL CETTE THÈSE FUT PRÉSENTÉE MASTER OF SCIENCE

YEAR THIS DEGREE CONFERRED / ANNÉE D'OBTENTION DE CE GRADE 1975

NAME OF SUPERVISOR / NOM DU DIRECTEUR DE THÈSE Dr. W.M. SAMUEL

Permission is hereby granted to the NATIONAL LIBRARY OF CANADA to microfilm this thesis and to lend or sell copies of the film.

L'autorisation est, par la présente, accordée à la BIBLIOTHÈQUE NATIONALE DU CANADA de microfilmer cette thèse et de prêter ou de vendre des exemplaires du film.

The author reserves other publication rights, and neither the thesis nor extensive extracts from it may be printed or otherwise reproduced without the author's written permission.

L'auteur se réserve les autres droits de publication; ni la thèse ni de longs extraits de celle-ci ne doivent être imprimés ou autrement reproduits sans l'autorisation écrite de l'auteur.

DATED / DATÉ July 23, 1975 SIGNED / SIGNÉ C. Gates

PERMANENT ADDRESS / RÉSIDENCE FIXE # 110-47 Sturgeon Rd. ST. ALBERT, ALBERTA

THE UNIVERSITY OF ALBERTA

ASPECTS OF THE ENVIRONMENT — LUNGWORM (NEMATODA:  
METASTRONGYLOIDEA) — BIGHORN SHEEP (*OVIS C. CANADENSIS*)  
SYSTEM

by

 CHARLES CORMACK GATES

A THESIS

SUBMITTED TO THE FACULTY OF GRADUATE STUDIES AND RESEARCH  
IN PARTIAL FULFILLMENT OF THE REQUIREMENTS FOR THE DEGREE  
OF MASTER OF SCIENCE

DEPARTMENT OF ZOOLOGY

EDMONTON, ALBERTA

FALL, 1975



W ADAMS  
75

UNIVERSITY OF ALBERTA  
FACULTY OF GRADUATE STUDIES AND RESEARCH

The undersigned certify that they have read, and recommend to the Faculty of Graduate Studies and Research, for acceptance, a thesis entitled "Aspects of the Environment -- Lungworm (Nematoda: Metastrongyloidea) -- Bighorn Sheep (*Ovis c. canadensis*) System" submitted by Charles Cormack Gates, in partial fulfilment of the requirements for the degree of Master of Science.

William McSain  
Supervisor

Jerome L. Mahid

J. J. J.

W. W. W.

W. F. W.

Date July 22, 1965

## ABSTRACT

The occurrence of lungworms of the genus *Protostrongylus* in bighorn sheep (*Ovis e. canadensis*) has been known since the 1920's but the complex system which involves lungworms, bighorn sheep, and the environment remains poorly understood.

The purpose of this study was to investigate the role of nutrition and other environmental factors in lungworm infections. Two neighboring bighorn sheep herds in the mountains of west-central Alberta were studied from September 1972 to May 1974.

Seasonal variation in the rate of lungworm larvae shedding in the feces of two bighorn sheep herds was documented. Two distinct periods of shedding were apparent. These were approximately coincident with summer and winter, summer being a period of low larval shedding and winter a period of a higher rate of shedding. The possibility that this phenomenon could be the result of dilution or concentration of larvae in a seasonally variable fecal mass was discussed.

Seasonal variation in the qualitative nutrition of the two sheep herds was evaluated using fecal nitrogen as an index for the estimation of forage crude protein, digestibility and gross energy content. Fecal protein (N X 6.25) proved to be a useful tool for the purposes of this study.

Simulated energy positions of both sheep herds for both winter periods of the study were compared using a bioenergetics model constructed with values from domestic and wild ruminant literature. The resulting observation was that although the energy position of both sheep herds declined from one winter to the next, lungworm burdens, as evaluated by larvae counts, fell significantly. The relevance of

nutrition in the etiology of heavy lungworm infections was discussed.

The observed decline in the intensity of lungworm infections followed a 30 percent decrease in rainfall from one preceding spring-summer season to the next, thus implicating ecological and/or environmental factors other than nutrition in the etiology of changing lungworm burdens.

Prenatal infection of four near term bighorn sheep with first- and third-stage lungworm larvae was demonstrated. This finding suggested a more cosmopolitan occurrence of the phenomenon in bighorn sheep than was previously suspected.

## ACKNOWLEDGEMENTS

I am particularly grateful to Dr. W.M. Samuel for his assistance in the preparation of this manuscript. I wish to extend sincere appreciation to Dr. R.J. Hudson for his assistance in the construction of a bioenergetics simulation model. Sincere thanks is offered to Mr. W.D. Wishart of the Alberta Fish and Wildlife Division for his sound advice and for assistance in obtaining funds and equipment. I would also like to thank Mr. R. Boyer of the Fish and Wildlife Division for his considerable help in transporting equipment and in the maintenance of vehicles. I extend appreciation to the National Parks Branch of Canada for permitting me to stay on Ya-Ha-Tinda ranch property while I was in the field.

Special thanks are given to Mr. L. Hildebrandt, Mr. B. Lajeunesse, and Mr. R. McClymont for their assistance in the lab.

This study would not have been possible without the support, patience, and encouragement of my wife, Janet, who assisted in every phase of the research.

The study was supported by the Alberta Fish and Wildlife Division of the Department of Recreation, Parks and Wildlife and by National Research Council of Canada Operating Grant No. A-6603 to Dr. W.M. Samuel.

## TABLE OF CONTENTS

ABSTRACT	v
ACKNOWLEDGEMENTS	vii
LIST OF TABLES	ix
LIST OF FIGURES	x
	Page
INTRODUCTION . . . . .	1
Description of the Study Area . . . . .	5
GENERAL METHODS . . . . .	11
Fecal Examination for Lungworm Larvae . . . . .	11
Nitrogen Analysis of Feces . . . . .	11
Recovery of Lungworm Larvae from Fetal Tissues . . . . .	12
RESULTS . . . . .	13
Climate and Phenology . . . . .	13
Fecal Protein . . . . .	15
Lungworm Larvae Counts . . . . .	20
Transplacental Transmission . . . . .	25
DISCUSSION . . . . .	28
Seasonal Variation of Lungworm Larvae in the Feces . . . . .	28
Bioenergetics, Nutrition, and Lungworm Infection . . . . .	33
Transplacental Transmission of <i>Protostrongylus</i> spp. . . . .	46
CONCLUSIONS . . . . .	48
LITERATURE CITED . . . . .	49



## LIST OF TABLES

Table	Page
1. Monthly temperature and precipitation data for the Ya-Ha-Tinda valley from May 1972 to April 1974 . . . . .	14
2. A summary of seasonal changes in fecal protein values for Scalp Creek and Eagle Creek sheep herds for the period January 1973 to May 1974 . . . . .	16
3. Weighted mean percent fecal protein values for Scalp Creek and Eagle Creek sheep herds for the periods January through April of 1973 and 1974 . . . . .	19
4. A summary of larvae count data for Scalp Creek and Eagle Creek sheep herds for January 1973 to May 1974 . . . . .	21
5. A summary of mean larvae count data for Scalp Creek and Eagle Creek sheep herds for the periods January to April 1973 and December to April 1974 . . . . .	24
6. A summary of larvae recovered by <i>in vitro</i> digestion of fetal liver . . . . .	26
7. A comparison of measured dimensions of twenty-one third-stage <i>Protostrongylus</i> spp. larvae recovered from Alberta bighorn sheep fetuses and published ranges for these dimensions . . . . .	27
8. A summary of transformed mean larvae counts adjusted for variations in fecal weight . . . . .	29

LIST OF FIGURES

Figure	Page
1. The study area, the Ya-Ha-Tinda valley, west-central Alberta . . . . .	7
2. The seasonal changes in percent fecal protein for Scalp Creek and Eagle Creek sheep herds during the period January 1973 to May 1974 . . . . .	18
3. The seasonal changes in mean larvae counts (ln) for Eagle Creek and Scalp Creek sheep herds during the period January 1973 to May 1974 . . . . .	23
4. A seasonal comparison of observed larvae counts (transformed from normal log values) and larvae counts adjusted by a concentration factor . . . . .	31
5. A schematic diagram of the bioenergetics simulation model . . . . .	35
6. The relationship between feed intake and forage quality . . . . .	37
7. A comparison of simulated weight changes for the periods November to April 1972-1973 and 1973-1974 for Scalp Creek and Eagle Creek sheep herds . . . . .	42

## INTRODUCTION

The complexity of environment-host-parasite systems reflects the interaction of multiple influences. The determinants involved can be separated into extrinsic and intrinsic factors, although this should not imply a functional distinction as interactions are the rule. Climate and weather are important extrinsic factors. They have been shown to influence resistance to infection (Webster 1970a) and are important etiologic factors which can regulate behavioral and/or physiologic patterns of intermediate hosts (Ollerenshaw 1966), definitive hosts (Geist 1971) and larval stages of parasites found outside the host (Crofton 1963, Levine 1963). As a result, the efficiency of the infective process can be enhanced or impeded by environmental conditions.

The complexity of intrinsic determinants of the outcome of parasitic infection makes their study difficult at best. Circannual physiologic rhythms may be linked with decreased resistance to parasitic activity at certain times of the year (Hudson 1970). Physiologic differences associated with sex, age, pregnancy and lactation may further moderate the response of a host to a parasite (Hudson 1973). Some experimental evidence suggests the presence of thresholds of antigenicity below which the host would remain relatively unresponsive (Dineen 1963). Prenatal or early infection might be expected to result in impairment of the immune response by induction of tolerance to parasite antigens (Kassai and Aitken 1967). Parasites may also influence hormonal balances in the host which, in turn, may alter the immune status (Solomon 1969). The

ability of animals to resist infection also appears to be controlled, in part, by inherited responses (McDevitt and Benacerraf 1969).

The involvement of host nutrition in resistance to some parasites is well documented (Chandler 1953, Frye 1955, Nathin 1973), although the relationship is not always clear. In wild ruminants this relationship may be confounded by seasonal effects of metabolic rhythmicity or feed intake cycles (Hudson 1970). Undernutrition and/or malnutrition resulting from deteriorating range conditions has been implicated as an underlying cause of heavy lungworm burdens (*Protostrongylus* spp.)<sup>1</sup> in Rocky Mountain bighorn sheep (*Ovis c. canadensis* Shaw, 1804) (Marsh 1938, Demarchi and Demarchi 1967, Forrester 1971, Uhazy *et al.* 1973, Stelfox 1974). At least two pieces of evidence suggest that undernutrition, as it affects host resistance to infection, is not necessarily a predisposing cause of an increase in the intensity of infection. Bighorn sheep in the Tarryall-Kenoshaw mountains of Colorado suffered a catastrophic reduction in herd size (95% mortality) in 1953 which was associated with heavy lungworm burdens and a lungworm-pneumonia complex (Buechner 1960, Bear and Jones 1973). Although the sheep population density was high, the range was not in a deteriorated condition, perhaps as a result of the low degree of range use by other ungulates (Bear and Jones 1973).

Information presented by Stelfox (1974) suggested that although winter range conditions for sheep in Jasper National Park in Alberta were poor, expected reproductive failures associated with undernutrition did not occur. Although the survival of juvenile sheep tended

---

<sup>1</sup>At least two species are found in bighorn sheep: *Protostrongylus stilesi* Dikmans, 1931 and *P. rushi* Dikmans, 1937.

to decrease with the proportion of forage per sheep, the net effect was still an increase in population size. Sheep density and lungworm burdens were high.

The importance of nutrition in the reproductive success of domestic ruminants is abundantly clear. Undernutrition may delay puberty in females (Yeates and Parker 1962). Nutrition regulates the release of gonadotropins from the anterior pituitary and subsequently affects ovarian activity (Allen and Lamming 1961). Millen (1962) found that reduced ovarian endocrine activity could cause infertility in females by inhibiting either production of healthy ova or implantation. Abortion or resorption of the fetus can be caused by severe inanition of the female (Millen 1962). Domestic ewes fed poor quality diets had a lower milk production and did not care for their lambs as well as did those fed adequate diets (Thompson and Thompson 1949, 1953). Verme (1963) working with white-tailed deer demonstrated that insufficient prenatal nutrition markedly slowed the growth rate so as to be readily measurable.

In bighorn sheep a reduction in the birth weight would result in a greater potential for heat loss to the environment, i.e., the surface area to mass ratio is increased. Hypothermy alone could account for the demise of weak, undersized neonatal lambs. The inability of severely undernourished dams to supply an adequate amount of milk could account for the mortality of a significant proportion of those lambs which survive the neonatal stage. The low mortality rate of lambs in Jasper National Park and the production of lambs at a comparatively normal rate (Stelfox 1974) suggests that the nutrition of these sheep herds had not yet reached a critical level. If the

endocrinological and energy dependent mechanisms which regulate reproductive success and lamb survival were not grossly affected by the condition of the range vegetation it is at least tenable that such an important homeostatic mechanism as resistance to infection may also have remained grossly unaffected.

As an ecological system the environment—lungworm—bighorn sheep complex remains poorly understood. Yearly variations in the intensity of infection of bighorn sheep with these parasites have been correlated with differences in precipitation during the vegetative growing season and summer months preceding the period of evaluation of the intensity of infection (Pillmore 1959a, 1961, Forrester and Senger 1964b, Forrester 1969, Uhazy *et al.* 1973). The variations were theoretically explained in terms of intermediate host and larval nematode ecology. Seasonal variation in the rate of lungworm larvae shedding in the feces has been reported (Couey 1950, Pillmore 1955, Forrester and Senger 1964b, Uhazy *et al.* 1973). Its etiology has not been defined satisfactorily; for example, it is possible that such variation is due simply to differential dilution of a constant number of larvae in a seasonally changing fecal mass.

No attempt has been made to study, in detail, the relationship between the intensity of lungworm infection in bighorn sheep and nutrition, although speculation is common (see literature cited on p. 2).

The present research was initiated to obtain information about selected aspects of the environment—lungworm—bighorn sheep system. It was conducted from September 1972 to May 1974 in west-central Alberta in cooperation with the Fish and Wildlife Division of the

Department of Recreation Parks and Wildlife of the Alberta Government. Two neighboring bighorn sheep herds were studied. The objectives of the study were: 1) to document short term variations in the nutritional status of free-ranging bighorn sheep; 2) to develop a preliminary bioenergetics model for this species given values for selected environmental variables; 3) to determine if seasonal lungworm larval shedding is the result of mechanical dilution in a changing fecal mass; 4) to investigate the short term involvement of nutrition in the intensity of lungworm infection and to consider the validity of the presumed relationship between heavy lungworm burdens and poor range conditions; and 5) to investigate the occurrence and geographic distribution of transplacental infection of bighorn sheep by lungworms of the genus *Protostrongylus*.

#### Description of the Study Area

The study area was located in the Red Deer River valley in the outer range of the Rocky Mountains about 13 kilometers east of the eastern boundary of Banff National Park (Twp. 32, Rge. 11, 12, W5th. Mer.). It is colloquially known as the Ya-Ha-Tinda valley (Fig. 1) which in the language of the Stoney Indians means roughly "mountain prairie." The valley is semi-open native grassland which is being gradually invaded by shrubby cinquefoil (*Potentilla fruticosa*) and/or dwarf birch (*Betula glandulosa*) depending on site factors.

Three major bighorn sheep winter ranges rim the valley. Two are grassland ranges (Fig. 1). A third (not shown) is an alpine range located south of the Red Deer River. This study centered on

Figure 1. The study area, the Ya-Ha-Tinda valley, west-central Alberta.



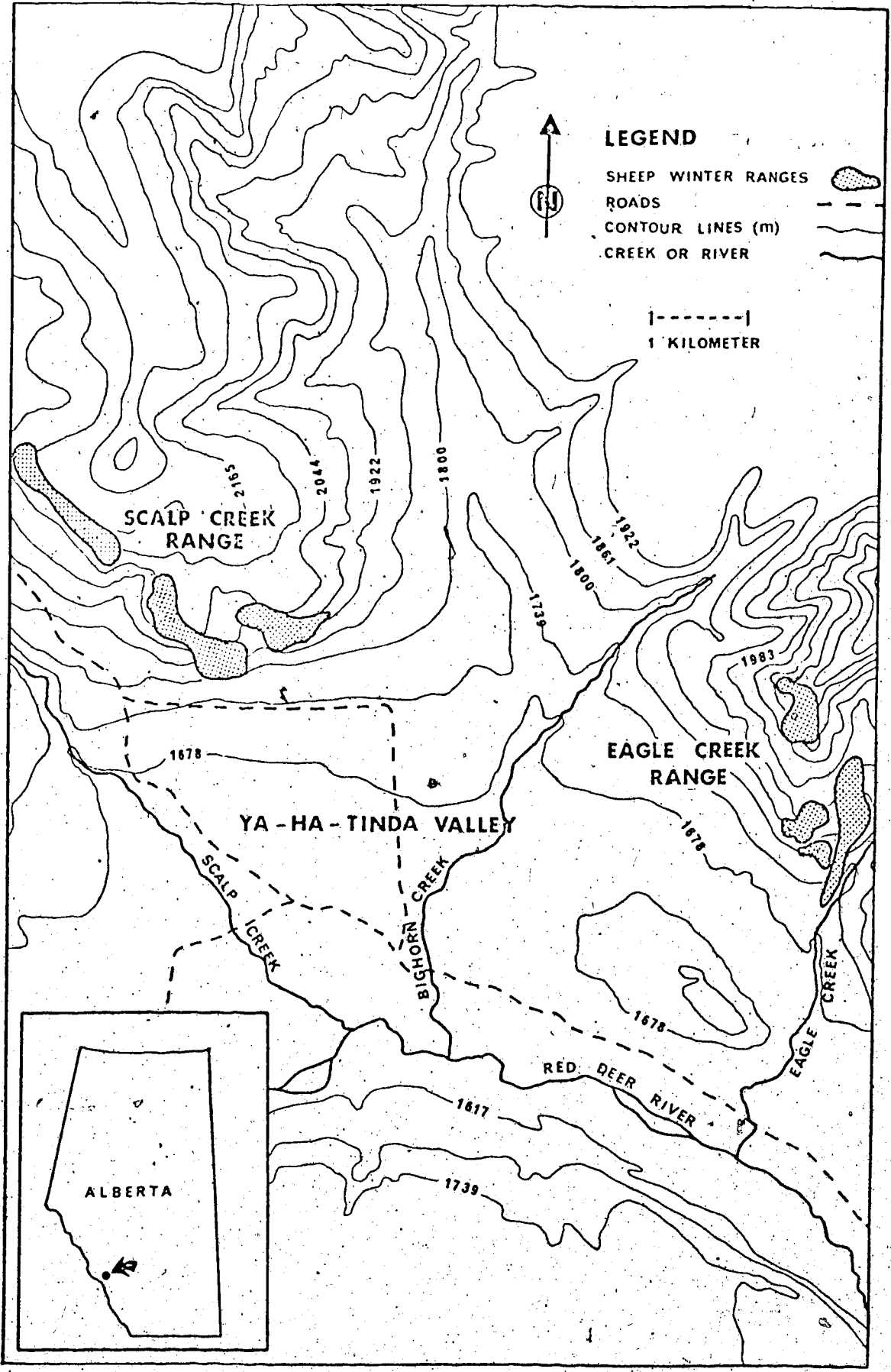

the grassland ranges since they were accessible during the winter months. One of these was located along the Scalp Creek drainage approximately five kilometers north of the Red Deer River. The other was located five kilometers to the east on the west bank of Eagle Creek.

The valley is characterized by a relatively mild microclimate due to the effect of the surrounding mountains. During the period May 1972 to May 1974, precipitation was higher in summer than in winter. The annual total was less than 65 centimeters. Soil mantles were thin and subsoils were rocky on the sheep winter ranges.

The basic floristic composition of the two winter ranges was determined by a step point method of analysis described by Evans and Love (1957). Both winter ranges could be divided into lower elevation and subalpine grasslands. The Scalp Creek lower elevation range occupied an elevation of 1922-2074 meters with a southwest aspect. In area it covered approximately 85 hectares. The dominant grass species in descending order of frequency of occurrence were *Agropyron dasystachyum* (13%), *Calamagrostis purpurascens* (11%) and *Koeleria cristata* (8%). Sedges made up 10% of the floristic composition. Important forbs were *Astragalus* spp. (10%), *Artemesia frigida* (6%), *Aster* sp. (6%) and *Stelleria longipes* (5%).

The Scalp Creek subalpine grassland was found at a slightly higher elevation (2074-2196 meters). It was located adjacent to the west end of the lower grassland range and also occupied a southwest exposure. It covered an area of about 79 hectares. This range was used at least as frequently as the grassland range by the Scalp Creek herd during the winter. *Elymus innovatus* (18%) was the predominant

grass species. Sedges made up 30% of the floristic composition. No forb species could be identified as being singularly important.

*Arctostaphylos uva-ursi* was the primary shrub (13%).

The Eagle Creek grassland range occupied from 1740—1985 meters in elevation on the west bank of Eagle Creek. The grassland was discontinuous, being interspersed with stands of spruce (*Picea glauca*) and aspen (*Populus tremuloides*, *P. balsamifera*) where the grade and moisture regime permitted the establishment of trees. This range occupied both the southeast and southwest slopes of a north—south oriented spur. In area it covered approximately 45 hectares. The terrain, soil and plant cover were varied. The predominant grass species on the west bank of Eagle Creek were *Koeleria cristata* (21%), *Elymus innovatus* (14%), and *Helictotrichon hookeri* (7%). Sedges comprised 9% of the stand by frequency of occurrence. *Artemisia frigida* (12%), *Astragalus* spp. (7%) and *Erigeron* sp. (4%) were the most important forbs. Shrubs occurred only infrequently. The soil was more rocky and unstable on the southwest slope of the spur. The predominant grasses here were *Calamagrostis purpurascens* (20%), and *Koeleria cristata* (9%). Sedges ranked 10% by frequency of occurrence. *Oxytropis* sp. (10%), *Astragalus* sp. (6%) and *Stelleria longipes* (4%) were the most abundant forbs. *Juniperus horizontalis* (10%) was the most prevalent shrub.

The Eagle Creek subalpine range was used infrequently by this sheep herd during the winter. It was approximately 30 hectares in area and occupied an elevation of 1985—2320 meters. The aspect was southwest. The predominant grasses were *Calamagrostis purpurascens* (21%) and a number of species of *Poa* (6%). Sedges had a frequency of

occurrence rating of 27%. The primary forb was *Oxytropis* sp. (10%). Shrubs were scarce in this stand.

The maximum number of sheep observed on the winter ranges were 60 and 50 for Scalp Creek and Eagle Creek ranges, respectively. A large herd of wapiti (*Cervus canadensis nelsoni* Bailey, 1935) (approximately 400 animals) also wintered in the valley but their use of sheep winter ranges was restricted primarily to the end of winter and early spring and was considered light (personal observation). Mule deer (*Odocoileus hemionus hemionus* Rafinesque, 1817) and white-tailed deer (*Odocoileus virginianus ochroumus* Bailey, 1932) were observed occasionally, especially during the spring and early summer. Three mountain goats (*Oreamnos americanus missoulae* Allen, 1904) were seen on one occasion during the fall of 1972 on the sub-alpine Eagle Creek grassland.

## GENERAL METHODS

*Fecal Examination for Lungworm Larvae*

In this thesis the term "sample" is used to indicate fecal pellets collected from a single bighorn sheep and "collection" to indicate all samples from a single herd at one sampling period.

Eight hundred and eight fecal samples were collected from the sheep herds on a monthly or bi-monthly basis during the period January 1973 to May 1974. Because the summer range was extensive and the sheep were scattered at this time, few samples were collected from July to October. Only fresh feces were collected. Samples were not identified with any particular sheep, but separate pellet groups were collected.

Feces were air dried in paper bags for three months. First-stage larvae of *Protostrongylus* spp. were recovered in a Baermann apparatus following a procedure described by Uhazy *et al.* (1973). Approximately four grams of dry feces (weighed to the nearest .01 gm) were processed using this technique. Larvae were counted in a Plexiglas counting chamber and the result expressed as larvae per gram of feces (LPG). LPG values were converted to natural logarithms and a mean LPG (ln) value per collection was determined (Uhazy *et al.* 1973). Uhazy *et al.* (1973) suggested that larvae counts over 1400 LPG probably represent "heavy" infections. An arbitrary value of 1000 LPG was chosen for comparative purposes in this study due to the small number of counts over 1400 LPG.

*Nitrogen Analysis of Feces*

Four hundred and ninety-five of the fecal samples collected were

analysed for total nitrogen content using the macro-kjeldahl method (A.O.A.C., 1965). Approximately 100 samples were run in duplicate at which time it was seen that the variation between duplicates was consistently less than 0.05%. Subsamples were both air dried and frozen. A comparison of analyses of air dried versus frozen then oven dried feces from the same sample showed virtually no difference in nitrogen content.

Percent nitrogen values were converted to percent fecal crude protein (N.X 6.25). Fecal crude protein (FP) values were used to estimate forage crude protein, gross energy content, apparent digestibility of dry matter and fecal weight per day using predictive equations from Hebert (1973).

#### *Recovery of Lungworm Larvae from Fetal Tissues*

Four near term bighorn sheep fetuses were provided by the Alberta Fish and Wildlife Division and Parks Canada. Specimens were preserved by freezing. Fetal tissues and placental cotyledons were mascerated then digested with pepsin-HCl at 37° (Cable, 1958). Third-stage larvae were recovered by washing the digested material through a series of screens, the smallest of which was a 200 mesh size (Fisher Scientific). Measurements of larvae were compared with those in Hibler *et al.* (1972) and Pillmore (1955).

## RESULTS

*Climate and Phenology*

Climatic and forage regimes varied considerably in the Ya-Ha-Tinda valley between the years 1972-1973 and 1973-1974. Although the mean temperatures were similar for the period May--September of 1972 and 1973 (8.9°C and 9.5°C, respectively) there was a 30 percent (11.5 cm) difference in precipitation (Table 1). The difference may be relevant when considering year to year differences in lungworm larval shedding rates.

Snow regimes, weather and the timing of spring green up are important determinants of the energy position of over-wintering big game animals. In the study area the winter of 1973-1974 was colder than that of 1972-1973 with a mean daily temperature for the period November to April of -8.8°C compared to -5.7°C for the previous year. Chinooks, which were frequent in winter 1972-1973, were far less common in 1973-1974 and snow persisted for longer periods of time on the winter ranges. Southern oriented slopes were free of snow cover for only 82 of the 180 days from November to April 1973-1974 compared to 132 days in 1972-1973. While only 17 centimeters of precipitation fell during this period in 1972-1973, 27.5 centimeters fell in 1973-1974. Due to the lack of snow in 1972-1973 sheep were able to move to alpine areas, away from their definitive winter ranges, during mild spells. In the winter of 1973-1974 the sheep were largely prevented from moving from their winter ranges by deep snow.

Spring growth of vegetation was first noticed on March 9, 1973. However, it was not until this new growth reached a height of

Table 1. Monthly temperature and precipitation data for the Ya-Ha-Tinda valley from May 1972 to April 1974.

Month	1972-73			1973-74		
	Temperature C	Mean	Precipitation (cm.)	Temperature C	Mean	Precipitation (cm.)
May	6.7	-	1.96	6.1	5.11	5.11
June	10.7	-	15.85	9.1	3.84	3.84
July	10.2	8.9	9.93	11.1	9.5	7.57
August	13.2	-	3.40	12.6	7.90	7.90
September	3.8	-	6.17	8.6	1.37	1.37
October	- 3.8	-	2.05	1.9	1.57	1.57
November	- 4.3	-	0.48	-11.2	2.92	2.92
December	- 8.5	-	5.28	-12.2	2.54	2.54
January	-11.4	-	0.74	-12.4	11.00	11.00
February	- 6.6	- 5.7	2.67	- 5.3	- 8.8	2.74
March	- 2.9	-	2.29	- 8.2	2.67	2.67
April	- 0.5	-	5.53	- 3.5	5.60	5.60



approximately 10 centimeters that it protruded above the vegetation standing from the previous year. Although this was a somewhat subjective evaluation it was supported by the timing of an abrupt rise in fecal protein values which occurred at the end of April, 1973. New growth of vegetation was not observed until the end of April the following year. The emerging vegetation grew through the overwintered plant cover when it was approximately 5 centimeters in height (end of April). This was a result of the packing effect of the heavy snow cover on the overwintered vegetation. The observation was again supported by the timing of the rise in fecal protein values.

#### *Fecal Protein*

The highest fecal protein (FP) values were obtained from the end of May to the beginning of June (Table 2, Fig. 2), these values apparently reflecting the complete availability of new forage. Fecal protein values declined from this point following advancing stages of maturity. The lowest FP values were attained during mid-winter. Early spring vegetative growth in March 1973 was the probable cause of a gradual increase in FP values until the beginning of May. Late winter increases in FP occurred in 1974 also, although there was no consistent trend. These increases may have been associated with mild weather, a decline in snow depth, resulting in an increase in availability of higher quality feed. Chemical analysis of overwintered forage generally shows plant protein to be at a low in late winter (McLean and Tisdale 1960, Johnston and Bezeau 1962, Demarchi 1968, Johnston *et al.* 1968). The rise in forage protein in late winter could be related to more selective feeding by the sheep. During January 1973, late November 1973

Table 2. A summary of seasonal changes in fecal protein values for Scalp Creek and Eagle Creek sheep herds for the period January 1973 to May 1974.

Location of Fecal Collection	Date	Sample Size	% Fecal Protein	Standard Deviation
Scalp Creek	January 10	6	8.31	0.676
	28	5	10.15	0.618
	February 15-24	16	8.90	0.343
	March 3-8	6	8.94	0.642
	April 24	11	9.96	0.970
	May 9	31	10.71	1.344
	June 23	2	16.57	7.623
	August 23	4	12.91	4.446
	October 28	1	12.66	---
	November 4-9	15	10.45	0.806
	25	11	11.67	0.572
	December 3-10	11	9.52	0.525
	January 5	15	8.70	0.669
	February 4	21	7.72	0.429
	15	15	8.42	0.345
	March 13	15	8.98	0.644
	25	15	8.83	0.591
	April 7	15	8.50	0.610
	30	15	8.75	0.714
May 25	33	14.26	1.241	
Eagle Creek	January 17	14	8.89	0.777
	February 27	11	9.83	0.809
	March 31	18	10.16	0.590
	April 26	15	10.18	0.578
	May 24-29	18	12.74	2.306
	June 7	13	15.99	3.571
	September 24	2	14.88	0.417
	November 3	16	10.55	0.659
	December 1	17	9.85	1.072
	11	12	8.95	0.597
	January 3	16	8.68	0.484
	February 5	15	8.40	0.598
	March 8	7	8.44	0.508
	12	15	9.74	0.603
	23	13	9.05	0.572
	May 1	15	10.37	0.625
	25	15	15.40	1.443

Figure 2. The seasonal changes in percent fecal protein for Scalp Creek and Eagle Creek sheep herds during the period January 1973 to May 1974.

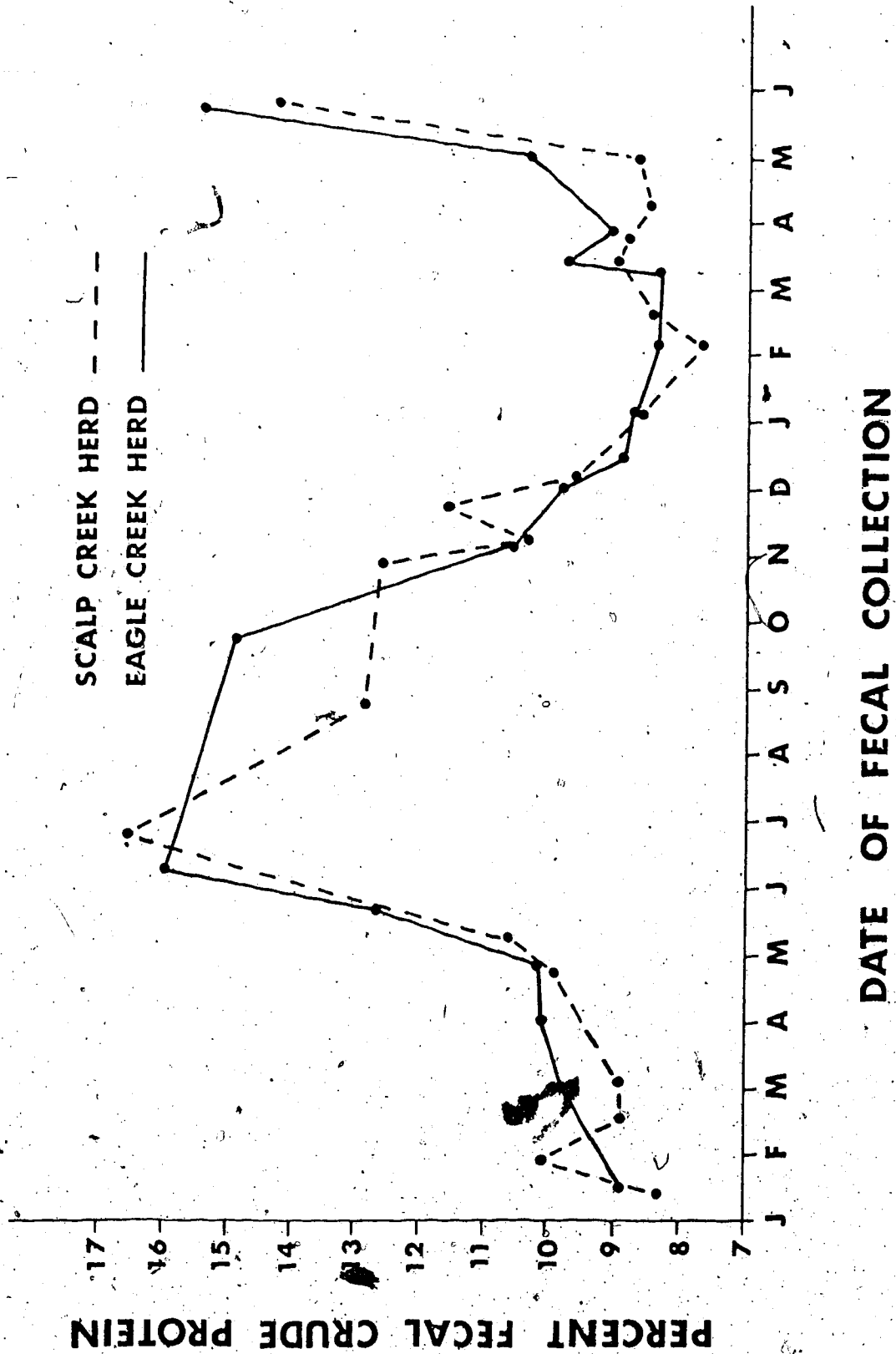

Table 3. Weighted mean percent fecal protein values for Scalp Creek and Eagle Creek sheep herds for the periods January through April of 1973 and 1974.

	Date of Fecal Collection	Percent Fecal Protein		Approximate Number Days at Value	
		Scalp Creek	Eagle Creek	Scalp Creek	Eagle Creek
<u>1973</u>					
January	10	8.31		16	
	17		8.89		41
	28	10.07		26	
February	15-24	8.9		16	
	27		9.83		32
March	3- 8	8.93		16	
	31		10.16		23
April	24	9.96		45	
	26		10.17		23
Mean (Weighted) Percent Fecal Protein:					
		8.48	9.64		
<u>1974</u>					
January	3		8.67		28
	5	8.70		28	
February	4	7.72		13	
	5		8.39		31
March	15	8.42		20	
	8		8.84		11
	12		9.74		5
	13	8.98		18	
	23		9.05		38
April	25	8.82		11	
	7	8.50			
	30	8.75	10.37	15	7
Mean (Weighted) Percent Fecal Protein:					
		8.57	8.88		

and March 1974 abrupt rises in fecal protein values occurred. These rises were attributed to the sheep moving temporarily onto alpine ranges.

In order to facilitate between herds and between year comparisons of fecal protein values, average values for percent fecal protein for the period January through April of 1973 and 1974 were calculated by a weighted mean procedure. An estimate was made of the number of days each herd was at a particular fecal protein value using field observation data. The weighted mean FP value was calculated by summing the products of percent fecal protein multiplied by the corresponding number of days at that value, then dividing the result by the total number of days in the period:

$$\text{Mean \% FP} = \frac{\sum (\% \text{ FP} \times \text{no. days})}{\text{Total days}}$$

The weighted mean values for fecal protein for the period January through April were generally lower in 1974 than in 1973 (Table 3). The differences for both herds were significant at the 99% confidence level with  $t$  values of 4.25 and 6.82 for the Scalp Creek and Eagle Creek herds, respectively. Percent FP values were significantly different between herds for 1973 ( $t = 2.30$ ,  $p < 0.05$ ) and 1974 ( $t = 2.81$ ,  $p < 0.01$ ). Percent FP values were higher both years for the Eagle Creek herd.

#### *Lungworm Larvae Counts*

Previous work (Uhazy *et al.* 1973, Holmes and Samuel unpub.) has shown lungworm larvae counts to have a log-normal distribution. Therefore, in this study all counts were transformed to their natural logarithms permitting the use of standard statistical techniques.

Larvae counts varied significantly ( $F^{35}_{772} = 15.516$ ) when analysed

Table 4. A summary of larvae count data for Scalp Creek and Eagle Creek sheep herds for January 1973 to May 1974.

Herd and Date of Fecal Collection	Sample Size	Mean LPG (ln)	Transformed Mean LPG	Standard Deviation (ln)
<u>Scalp Creek</u>				
January 10	14	5.555	259	0.802
28	5	4.613	101	1.048
February 15-24	18	5.446	232	0.460
March 3- 8	8	6.165	476	0.672
April 24	16	6.348	571	0.832
May 9	35	4.735	114	1.395
June 23	2	3.198	24	0.694
August 23	3	3.122	23	0.490
November 4- 9	38	3.516	34	1.346
14	13	5.098	164	1.305
December 3-10	29	4.637	103	1.136
January 5	35	5.003	149	0.768
February 4	27	5.396	215	0.905
15	25	5.485	241	0.660
March 13	39	5.699	299	0.626
25	34	5.656	286	0.994
April 7	35	5.022	152	1.021
30	30	5.295	199	0.690
May 25	34	3.225	25	1.259
<u>Eagle Creek</u>				
January 17	22	6.148	468	0.668
February 27	14	5.636	280	0.904
March 31	20	6.351	573	0.460
April 26	21	6.152	470	0.970
May 24-29	22	3.989	54	0.836
June 7	12	4.572	98	0.584
September 24	2	4.195	66	0.265
November 3	22	4.343	77	1.225
December 1	35	3.855	47	1.379
11	19	4.668	106	0.725
January 3	35	4.343	77	1.138
February 5	31	4.825	125	0.930
March 8	8	5.504	246	0.975
12	28	5.304	201	0.660
23	19	5.350	211	0.909
May 1	27	5.218	185	0.930
25	31	3.691	40	1.236

Figure 3. The seasonal changes in mean larvae counts (ln) for Eagle Creek and Scalp Creek sheep herds during the period January 1973 and May 1974.



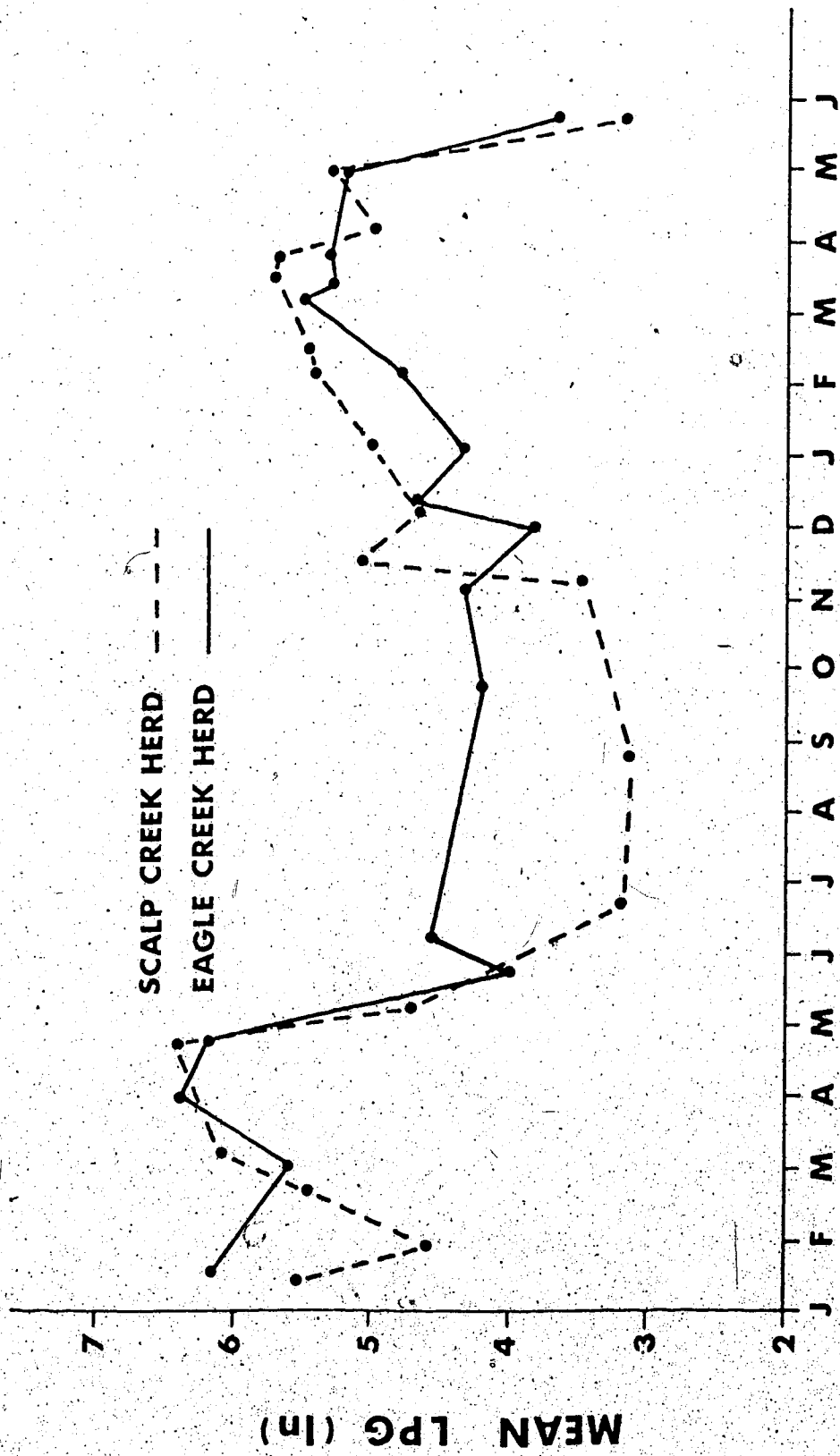

DATE OF FECAL COLLECTION

Table 5. A summary of mean larvae count data for Scalp Creek and Eagle Creek sheep herds for the periods January to April 1973 and December 1973 to April 1974.

Period	Herd	Sample Size	Mean LPG (1n)	Transformed		Number 1000 LPG	Percent 1000 LPG
				Mean LPG	Mean LPG		
January to April 1973	Scalp Creek	61	5.7333	309	5	8.2	
December to April 1974	Eagle Creek	77	6.1088	450	8	10.4	
January to April 1973	Scalp Creek	254	5.2817	197	5	2.0	
December to April 1974	Eagle Creek	171	4.7409	115	0	0	

by collection group (Table 4). Major variation in both herds resulted from three distinct phases of larval output (Fig. 3): January through April 1973 (a period of high larval output), May through November 1973 (a period of low larval output), and December 1973 through April 1974 (another period of high larval output). The beginning of another period of low larval shedding was evident in May 1974.

The transformed mean LPG value for the Scalp Creek herd during January to April 1973 was 309 ( $\ln = 5.7333$ ). This mean count declined to 197 larvae per gram ( $\ln = 5.2817$ ) during December to April 1973-1974 (Table 5). The difference was significant at the 99% confidence level. Likewise the transformed mean LPG value for the Eagle Creek declined from 450 ( $\ln = 6.1088$ ) to 115 ( $\ln = 4.7409$ ). This difference was highly significant ( $p < 0.001$ ). The percent of larvae counts over 1000 LPG also declined from one winter to the next (Table 5).

The transformed mean winter LPG value for the Scalp Creek herd (Table 5) in 1973 was significantly lower ( $t = 2.59$ ,  $p < 0.01$ ) than that for the Eagle Creek herd, but significantly higher ( $t = 5.09$ ,  $p < 0.01$ ) in winter 1974.

#### *Transplacental Transmission*

Tissues from four near term bighorn sheep fetuses from Alberta were examined for *Protostrongylus* spp. larvae. All fetuses were collected from different sheep herds (Table 5). Fetal liver, lungs and placental cotyledons were digested *in vitro*. Third-stage *Protostrongylus* spp. larvae were recovered from the livers of all fetuses and what appeared to be first-stage larvae were recovered from two of them (Table 6). No larvae were found in the fetal lungs or cotyledons.

Table 6. A summary of larvae recovered by *in vitro* digestion of fetal liver.

Collection Date	Location	<i>Protostrongylus</i> Larvae Recovered	
		Third Stage	First Stage
June 4/74	Sheep River	14	0
May 23/74	Jasper Nat. Park	46	0
April 17/75	Jasper Nat. Park	14	7
May 11/75	Jasper Nat. Park	60	6

The larger third-stage larvae measured 480—620 microns long and 30—38 microns wide. Descriptive measurements compared favorably with published dimensions of third-stage *Protostrongylus* spp. larvae (Table 7).

Table 7. A comparison of measured dimensions (in microns) of twenty-one third-stage *Protostrongylus* spp. larvae recovered from four Alberta bighorn sheep fetuses and published ranges for these dimensions.

Length of Larva	Width of Larva	Length of Esophagus	Excretory pore from ant. tip	Anus from post. tip
496	35	124	80	40
566	30	133	80	38
564	32	133	80	38
575	34	133	89	40
566	34	142	89	40
539	30	141	89	39
637	34	177	90	37
566	34	150	90	40
504	30	133	90	30
548	31	150	80	38
548	31	133	90	35
566	30	142	80	38
620	36	177	90	40
611	33	150	85	40
570	38	130	89	40
520	35	130	85	33
480	30	125	82	33
480	30	130	80	35
480	32	135	84	36
520	36	140	90	38
500	37	140	85	36
<u>RANGES</u>				
480-637*	30-38	124-177	80-90	30-40
504-600**	30-37	144-195	80-97	32-40
532-606***	33-40	---	---	---

\*This study

\*\*Pillmore 1955

\*\*\*Hibler *et al.* 1972

## DISCUSSION

*Seasonal Variation of Lungworm Larvae in the Feces*

The possibility exists that the observed seasonal variation of larval shedding is due to dilution or concentration of larvae in a seasonally variable fecal mass. Absolute fecal weight per day varies with digestibility of dry matter inasmuch as the feces represent the undigested portion of the feed. A predictable linear relationship exists between digestibility and fecal weight (in grams per day) for bighorn sheep according to the equation  $Y = 912.8 - 8.89 \text{ dig.} \pm 15.71$  (Hebert 1973). Regardless of the accuracy of the equation it is useful in demonstrating the changes in fecal weight and subsequent effect on larval concentration. This is accomplished by expressing fecal weight for each digestibility value as a percent of the maximum predicted fecal weight. The concentration factor is then the difference of each percent fecal weight from 100% (Table 8). LPG values are adjusted by transforming the natural log mean values to normal values then subtracting the portion which could be attributed to concentration (Table 8).

An adjustment for larval concentration makes little difference to the seasonal cycle of larval shedding as is evident in Figure 4. Therefore, larval entry into the digesta is not constant from season to season and thus probably reflects the reproductive activity of the adult worm population and/or changes in the competency of the response of the host to the parasite.

Short term or seasonal variations in the rate of larval shedding have been reported by Couey (1950), Pillmore (1955), Forrester and

Table 8. A summary of transformed mean larvae counts adjusted for variations in fecal weight.

Location of Fecal Collection	Date	Transformed LPG	Concentration Factor (%)	Adjusted LPG
Scalp Creek	January 10	257	2.04	253
	28	101	8.14	93
	February 15-24	232	4.18	222
	March 3-8	476	4.18	456
	April 23	182	7.75	168
	May 9	114	10.30	102
	June 23	25	30.68	17
	August 23	23	17.99	19
	November 4-19	34	9.46	30
	14	164	13.69	141
	December 3-10	103	6.25	97
	January 5	149	3.40	144
	February 4	221	0.00	221
	15	241	2.43	235
	March 13	299	4.38	285
	25	286	3.82	275
	April 7	152	2.70	148
30	199	3.57	192	
May 25	25	22.66	19	
Eagle Creek	January 17	468	1.79	459
	February 27	280	5.13	266
	March 31	573	4.15	549
	April 26	470	6.32	440
	May 24-29	54	15.46	45
	June 7	97	26.97	71
	September 24	66	22.99	51
	November 3	77	7.64	71
	December 1	47	5.20	45
	11	106	1.99	104
	January 3	77	0.99	76
	February 5	125	0.00	125
	March 8	246	0.20	245
	12	201	4.80	192
	23	211	2.36	206
May 1	185	7.04	172	
25	40	22.66	31	

Figure 4. A seasonal comparison of observed larvae counts (transformed from normal log values) and larvae counts adjusted by a concentration factor.



### EAGLE CREEK HERD

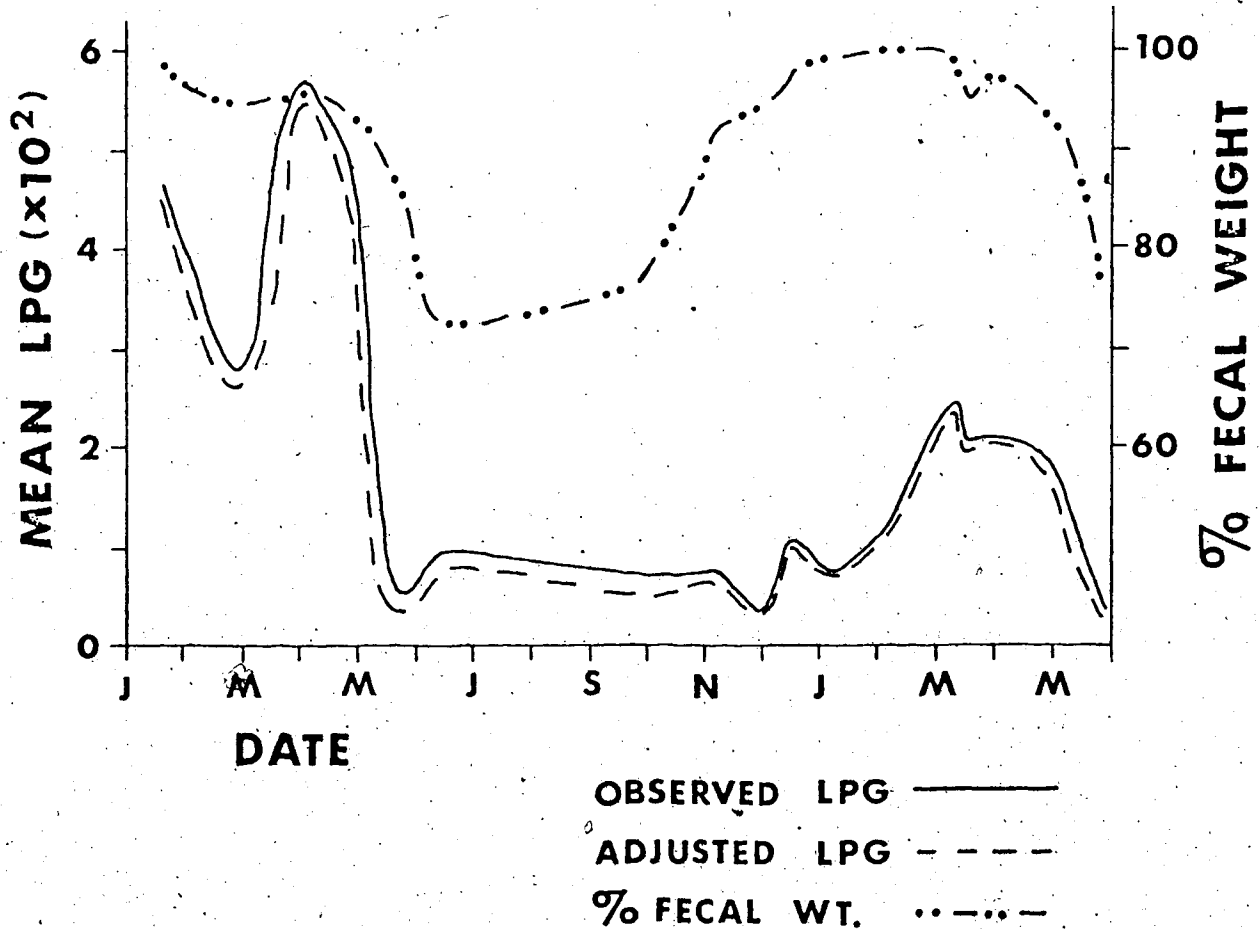

### SCALP CREEK HERD

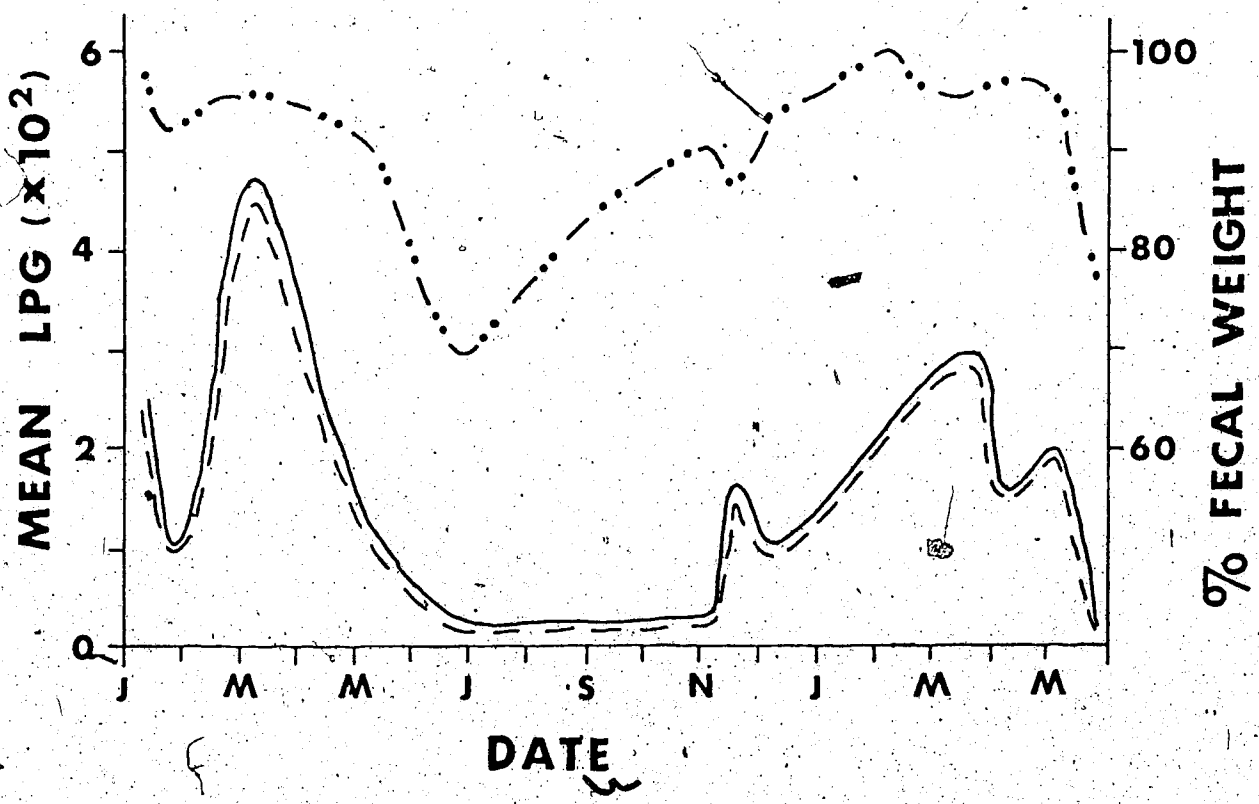

Senger (1964b) and Uhazy *et al.* (1973). The results of this study concur with the above in finding definite seasonal differences in rates of larval shedding. Two distinct periods of shedding are apparent; these coincide approximately with summer and winter, summer being a period of low larval shedding and winter a period of a high rate of shedding. The etiology of the phenomenon is not known. Forrester and Senger (1964b) suggested that, "seasonal variations may be connected with changes in type of feed, stress associated with harsh winter weather, breeding, pregnancy and lambing, or with some biological characteristic of the lungworm itself such as life span or infectiousness." Hudson *et al.* (1970b, 1972) demonstrated that seasonal variation in the rate of larval shedding in captive bighorn sheep was independent of feed quality, harsh winter weather, breeding, pregnancy and lambing.

Intrinsic physiologic factors or some inherent reproductive or developmental characteristic of the parasite may be involved in the etiology of this phenomenon. Some wild ruminants exhibit marked seasonal rhythmicity in metabolic rate, rate of gain, apparent maintenance energy requirements and feed intake (Cowan 1962, Wood *et al.* 1962, Silver *et al.* 1969, Thompson *et al.* 1973). Such factors could be linked with seasonal cycling of immunological reactivity. Seasonal variation in the immune response and prevalence of certain antibodies have been reported (Stone 1956, Hudson *et al.* 1971, Sidkey *et al.* 1972).

The occurrence of reproductive diapause of adult worms and arrested development of larval stages are other potential contributors to the phenomenon of seasonally variable larval shedding rates.

Regardless of the mechanism(s) involved it is important to

recognize that the production of high numbers of larvae during winter probably represents "a highly evolved host-parasite association with the parasite adapting to insure transmission," (Uhazy *et al.* 1973).

#### *Bioenergetics, Nutrition, and Lungworm Infection*

A bioenergetics simulation model was constructed to compare the energy positions of the two sheep herds in relation to changing lungworm burdens during the periods November to April 1972-1973 and 1973-1974. Input variables collected during the study were percent fecal protein, ambient temperature, wind velocity and cloud cover. Appropriate data for the determination of the effects of snow cover were not obtained during the study. This factor is discussed later in an explanation of the results of the bioenergetics simulation.

Sources for the relationships used in the construction of the model were Blaxter (1964), Silver *et al.* (1969), Webster (1970b), Zulberti and Reid (1972), Ammann *et al.* (1973), Hebert (1973), Moen (1973), and Robbins *et al.* (1974). The relationships and equations used were derived from literature on domestic and wild ruminants.

The schematic bioenergetics model presented in Figure 5 depicts the channels of energy assimilation and dissipation considered. The model operated on a one day timestep and reported on a three day basis for the period November to April (180 days).

1) *Determination of energy assimilation.* Differences in nitrogen loss by the fecal route can reflect changes in dietary quality. As a result fecal index methods have been developed to estimate forage crude protein (CP) (Raymond 1948, Hebert 1973) and digestibility of dry matter (DIG) (Lancaster 1949, Langlands *et al.* 1963, O'Donovan *et*

Figure 5. A schematic diagram of the bioenergetics simulation model.

REFERENCES

1. Hebert 1973.
2. Ammann et al. 1973.
3. Blaxter 1964.
4. Zulberti and Reid 1972.
5. Webster 1970b.
6. Moco 1973.
7. Silver et al. 1969.
8. Robbins et al. 1974.

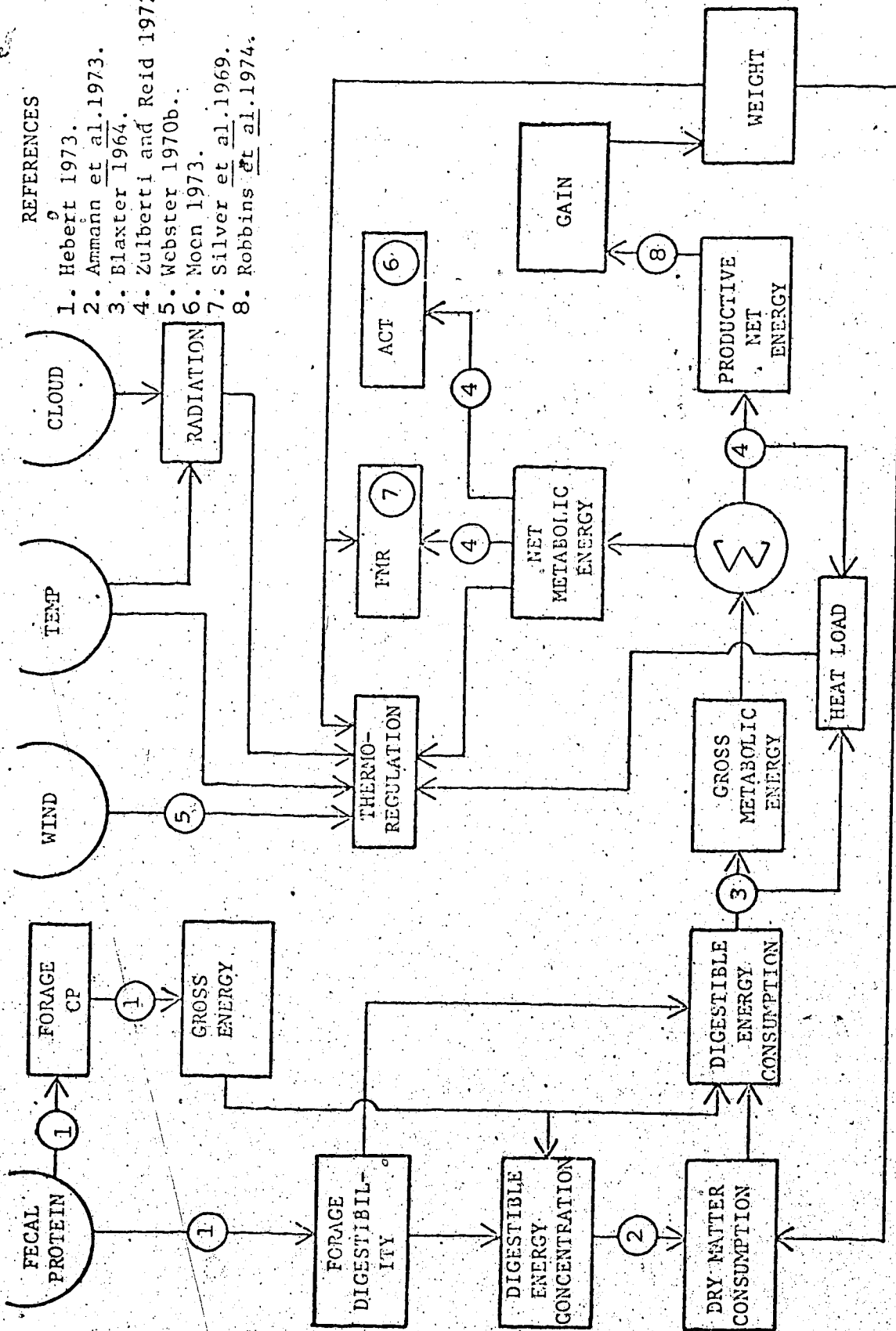

*al.* 1967, Hebert 1973). Hebert (1973) provides equations for the prediction of these parameters from fecal protein (FP) with data from bighorn sheep:

$$CP = - 0.94 + 1.034 FP$$

$$DIG = 50.53 + 1.426 FP .$$

The gross energy (GE) content of natural bighorn sheep forages was shown to be related to CP (Hebert 1973):

$$GE = 4.078 + 0.02168 CP .$$

The greatest departure from a linear relationship occurs during the early summer when the energy content of forage is greatest and CP is declining. This model was not concerned with this period.

From values for gross energy and digestibility the digestible energy concentration (DEC) of the feed was calculated.

Studies of wild and domestic ruminants have shown that there is a positive correlation between dry matter intake and caloric density for diets of low quality and a negative correlation for highly digestible diets. For forages of low to medium quality, intake is controlled by the physical distention of the rumen; the intake of higher quality forage is controlled chemically by volatile fatty acid production (Montgomery and Baumgardt 1965). When these relationships are illustrated graphically (Fig. 6) the point of intersection of the two lines represents the threshold where digestive tract fill begins to limit intake. Ammann *et al.* (1973), working with white-tailed deer fawns, found the point of inflection in the relationship between feed intake and digestible energy concentration to occur at 2.17 Kcals/gram. In the present model this point of inflection was used, and the slope of the

Figure 6. The relationship between feed intake and forage quality.

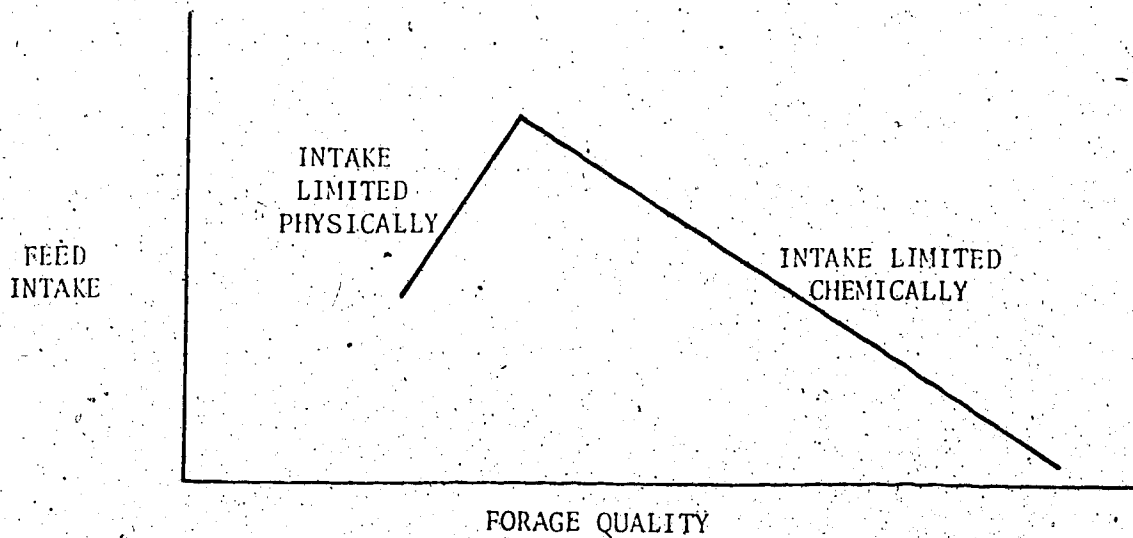

lines remained the same but the magnitude of the feed intake values was adjusted so that weight loss at the end of the first 180 day simulation period was approximately the same as the initial weight. This manipulation does not affect the comparative value of the model and avoids complications associated with extreme weight loss.

Gross metabolic energy (GME) was assumed to be 82% of DE (Blaxter 1964).

## 2) Heat production.

### a) Metabolic Rate

The basal metabolic rate (BMR) of bighorn sheep has not been determined. However, a mean value is available for the fasting metabolic rate (FMR) of adult white-tailed deer (Silver *et al.* 1969). Since complete repose is seldom ever attained in the wild, FMR is probably a more realistic basis from which to calculate energy production. Kleiber (1961) preferred the use of FMR because he believed that it was a reasonable representation of the heat production of animals under usual conditions.

The mean reported value of FMR for white-tailed deer in winter coat was  $97.1 \cdot X \cdot BW^{.75}$  Kcal/day (Silver *et al.* 1969).

b) *Heat of Fermentation*

The heat produced during digestion and metabolism of food is called the heat of fermentation (HF). It becomes an important factor in the heat balance of a homeotherm when the thermal environment results in heat loss greater than the heat produced by normal metabolism and activity. In the present model HF is assumed to be 8.4 percent of DE (Moen 1973).

c) *Heat Produced by Activity*

The activity patterns of wintering bighorn sheep show a tendency toward reduced energy expenditure by a reduction in social interaction and other activities which would result in unnecessary energy expenditure (Geist 1971). The winter activity patterns described by Geist (1971) are similar to those described by Moen (1973) for white-tailed deer. Therefore, the energy costs per day for various activities (ACT) used in the simulation were taken from Moen's data.

Energy is not used 100 percent efficiently for FMR and activity. The total energy required to support the maintenance function was resolved by Zulberti and Reid (1972) with the following equation:

$$EM = \frac{100}{EFFI} (FMR + ACT)$$

where EM is the metabolizable energy requirement of maintenance (Kcal/day)

EFFI is the efficiency with which energy is used to support the maintenance function

FMR and ACT are fasting metabolic rate and activity energy costs as previously described.



The energy (GME) remaining after EM and thermoregulatory requirements (see below) have been met is available for growth or other productive processes. This remaining GME is termed productive metabolic energy (PME). The efficiency ( $EFF^2$ ) with which PME is utilized for body weight gain is a function of the GME concentration of the diet (Zulberti and Reid 1972). PME ultimately used for production is termed productive net energy (PNE).

$$PNE = PME \times EFF^2.$$

PME not used for production was included in the heat load.

The final heat load (HTLD) was calculated as the sum of heat produced by fasting metabolism, the heat of fermentation, the heat produced by activity, the difference between the productive metabolic energy and productive net energy, and the difference between the energy used for maintenance and total dissipation (TD) which is a collective term for FMR + ACT.

$$HTLD = FMR + ACT + PME - PNE + EM - TD.$$

3) *Heat loss.* In this model heat exchange with the environment was considered in the form of radiation flux, convection, conduction, and evaporation. Although animals do regulate heat loss behaviorally this factor was not considered due to a lack of information. Cloud cover and wind velocities were recorded daily during the study. In order to facilitate execution of the model, values for these parameters were averaged for the periods November to April 1972-1973 and 1973-1974 and a random number generator was applied using the standard deviation for each with a lower limit set at zero. Ambient temperature trends were estimated from a graph of the changes in mean daily

temperature.

Total daily solar radiation values for the period were derived from data presented by Buffo *et al.* (1972) for SSE and SSW aspects of a 30 degree slope at a latitude of 50°N. Equations and relationships for the prediction of energy exchanged between the simulation animal and the environment were taken from Webster (1970b) and Moen (1973). Factors considered were surface area, tissue insulation, external insulation, wind velocity, ambient temperature, cloud cover and radiation.

If heat loss exceeded heat production an additional energy cost was required to maintain homeothermy (THERM):

$$\text{THERM} = \text{HLOS} - \text{HTLD} .$$

4) *Weight changes.* Robbins *et al.* (1974) determined the caloric content of gain (Kcal/gram) for white-tailed deer based on ingesta free body weight (Kg). In the present model the body composition of wild sheep was assumed to be similar to deer. Weight loss assumed a 100 percent efficient use of tissue. If the productive metabolic energy was a positive value, productive net energy divided by the energy content of gain resulted in a value for positive weight gain (Kg/day).

The initial weight of the simulation animal was set at 55 Kg, approximately that of a two- to three-year old ewe.

*Bioenergetics simulation results.* Simulated weight changes for the model sheep under conditions delineated for both sheep herds studied and for both periods are illustrated in Figure 7. At the end of each period it is seen that the weights resulting from both sets of conditions (Scalp Creek and Eagle Creek) are very close. This suggests that the observed significant differences in fecal protein, and thus forage

Figure 7. A comparison of simulated weight changes for the periods  
November to April 1972-1973 and 1973-1974 for Scalp  
Creek and Eagle Creek sheep herds.

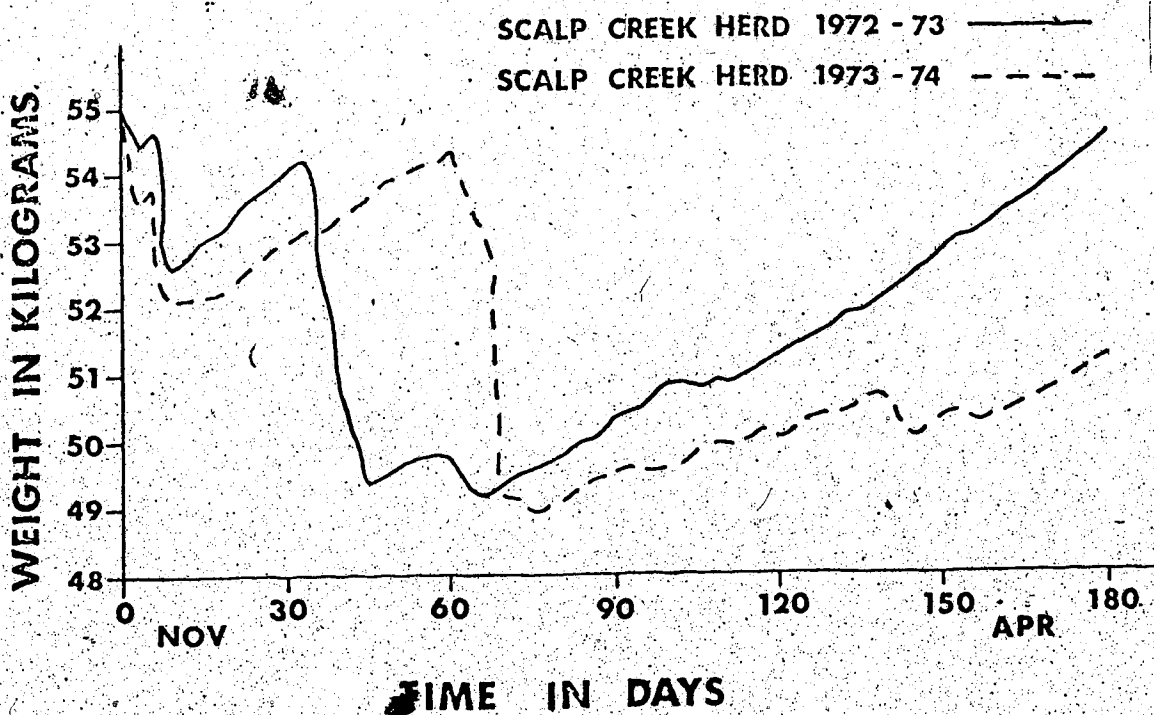
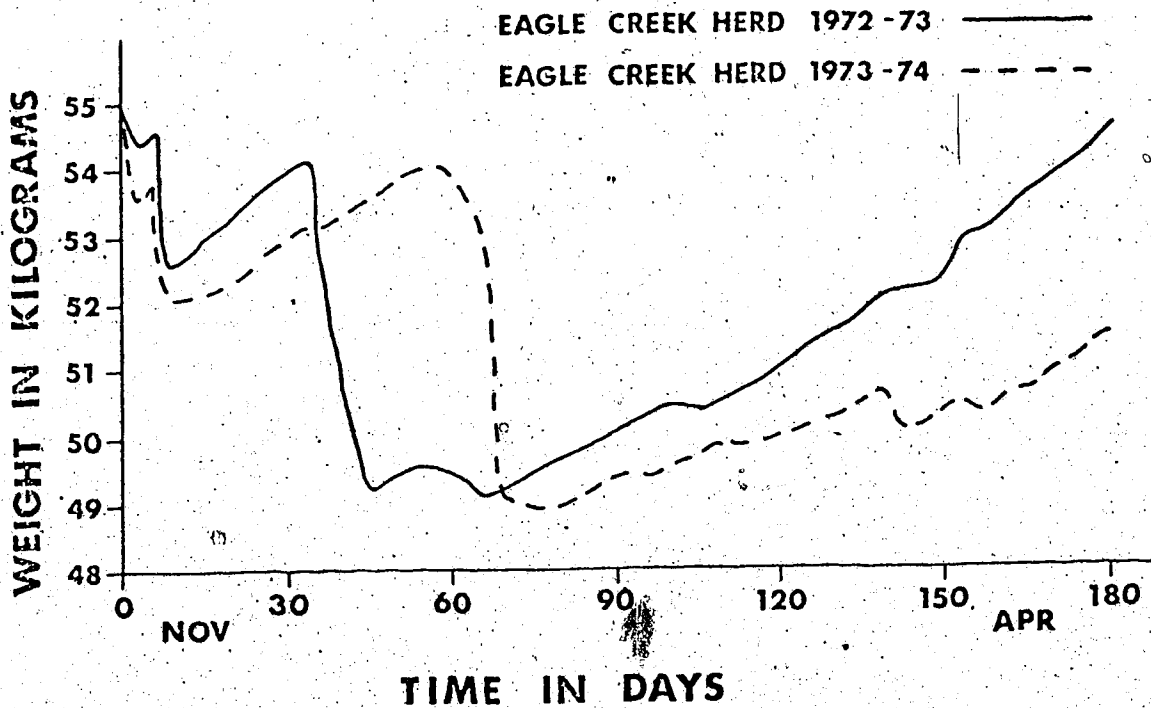

quality, between herds are not biologically significant when a complex of other environmental and physiologic factors are considered.

The difference in weight loss between years is apparent. In November to February 1972-1973 the mean simulated weight change was 0.8% (.44Kg) for the first simulation conditions. In the second simulation period it was 6.6%. The weight losses reflect relative differences in climate and feed quality between the winters.

One important factor for which appropriate data were not available was differences in snow regimes between winters. Although data were presented on the approximate number of days winter ranges were covered with snow, this was not adequate to allow a determination or even a guess as to possible effects of snow cover on restriction of feed intake and additional energy costs. Had this factor been included the magnitude of the difference in simulated weight losses between simulation periods could have been even greater.

Poor nutrition has frequently been demonstrated to result in the establishment of greater parasite burdens than when animals are well nourished (Lunker and Newmayer 1947, Laurence *et al.* 1951, Chandler 1953, Hunter 1953, Gibson 1963, Brunson 1964). Experimental evidence of this relationship and the frequent observation of high lungworm burdens in bighorn sheep associated with deteriorated range conditions has led to the assumption that poor nutrition is a cause of heavy infections of this parasite. However, investigations of the relationship between nutrition and parasitism are not always conclusive; some results are ambiguous (Gordon 1964, Goldberg 1965, Deo *et al.* 1967, Graber 1971), others are contrary to what might be expected (Kauzal

1934, Davey 1936, Kloosterman *et al.* 1973). In most cases experimental diets have been designed to maximize nutritional differences between test groups. This approach fails to take into account the dynamic and complex nature of parasite-host interactions.

Resistance to parasitic infection may depend on factors other than nutrition. Animals are profoundly influenced by their social environment (Ferguson 1969) as well as by elements of the physical environment such as climate and weather (Viereck 1963, Webster 1970a) and exposure to hypoxia at high altitudes (Highman and Atland 1964). There is some evidence to suggest that constant heavy exposure to infection can lead to immunological exhaustion (Dineen and Wagland 1966). Dineen (1963) presents experimental evidence which indicates the presence of thresholds of antigenicity below which the host would remain relatively unresponsive. Underlying all factors mentioned are hereditary components which can play an important role in determining the exact configuration of host susceptibility and resistance patterns (Whitlock 1958).

Certainly in long standing parasite-host relationships such as *Protostrongylus* spp.—*Ovis canadensis* (Pillmore 1955), adaptation on the part of host and parasite would work to maximize survival of both.

There is a paucity of evidence which suggests that resistance to parasitic infection is lowered only when nutrition falls below a critical level (Downey *et al.* 1972). It is conceivable that such a critical level of nutrition was exceeded at all times during this study and therefore nutrition would not have been an important factor affecting lungworm infection. The observation made during this study was that although the energy position of both sheep herds declined in the second winter from the first, the lungworm burdens of both herds fell significantly.

Although this can hardly be interpreted as evidence of a lack of relationship between nutritional status and lungworm infection it does demonstrate that at the given levels of nutrition the intensity of lungworm infection appeared to be related to factors other than nutrition.

Evidence presented earlier (see page 2) from the Tarryll-Kenoshaw Mountains sheep herd and from interpretation of data presented by Stelfox (1974) suggests that undernutrition may not be as important a factor as previously considered in the etiology of heavy lungworm infections in bighorn sheep.

Etiologic factors quite unrelated to the complex of genetics, environmental stresses, nutrition and resistance can be exceedingly important to the course of parasitic infection. Environmental factors affecting the survival of free living larval stages, intermediate hosts and exposure of the definitive host to infective larvae may be at least as important if not more important than the ability of the host to resist infection.

Year to year differences in the rate of *Protostrongylus* spp. larval shedding appear to be related to precipitation in the previous spring or summer (Pillmore, 1959b, 1961; Forrester and Senger 1964b, Forrester 1969, Uhazy *et al.* 1973). The data collected during the present study show a significant decrease in larval output during winter 1974 from a higher rate of larval shedding during winter 1973. This decrease was paralleled by a 30 percent decrease in rainfall from the summer of 1972 to the summer of 1973.

It is possible that the intensity of lungworm infection, on a herd basis, is density dependent for reasons other than forage quality or

nutritional status. Certainly the greater the density of infected sheep the greater the saturation of the range with first-stage lungworm larvae. Also, a greater density of sheep results in an increase in grazing pressure, thus a greater probability of ingesting infected snails.

It can also be anticipated that under these conditions a greater number of snails, which serve as the intermediate host for the lungworm (Monson and Post 1972), will acquire infections. A result of these processes may be an infectious system which accelerates towards a point where the sheep are not able to adjust to the enormous parasite load, or where secondary bacterial or viral infection sets in, or both.

#### *Transplacental Transmission of Protostrongylus spp.*

Evidence of transplacental transmission of *Protostrongylus* spp. in bighorn sheep prior to 1972 was mostly circumstantial (Hibler *et al.* 1974). The evidence was based on observations of patent infections in young wild and captive lambs in Wyoming (Rufi 1961, Howe 1965), Colorado (Pillmore 1956, 1959a) and Montana (Forrester and Senger 1964a).

Definitive proof of prenatal infection of bighorn sheep was presented by Hibler *et al.* (1972, 1974). Environmental anomalies associated with the herds from which fetuses were obtained by these workers caused reason to question the general geographic distribution of prenatal infection in bighorn sheep. Uhazy *et al.* (1973) were not able to recover infective larvae from lungs of nine bighorn fetuses from Alberta and with some additional circumstantial evidence concluded that, "under our ecological conditions, prenatal infection is not general." The current discovery of third-stage *Protostrongylus* spp. larvae in four Alberta bighorn fetuses collected in Alberta indicates a more cosmopolitan



distribution of the phenomenon.

Prenatal infection obviously enhances the efficiency of the life cycle of the lungworm. It may have important immunological consequences (Hudson 1973) such as induction of tolerance or with constant exposure to reinfection, a permanent immunological impairment. Prenatal infection can be important to lamb survival under some circumstances, e.g. the mortality of 98% of the lamb crop by September in certain Colorado sheep herds in recent years has been attributed to verminous pneumonia (R. Lange, personal communication).

## CONCLUSIONS

Nitrogen analysis of feces collected from free-ranging bighorn sheep appears to be a valuable technique for assessing seasonal dynamics of qualitative nutrition for this species. Its application to the study of other wild ruminant species should be investigated.

Consideration should be given to the possibility that in the study of lungworm infection with a system of values, or hierarchical order of ecological priorities, nutrition may be ranked very low. The physiological and nutritional aspects of this infectious system may have been overemphasized in past research. More emphasis should be placed upon ecological aspects which affect the efficiency and intensity of transmission of the parasites between host species.

Prenatal infection of wild sheep with *Protostrongylus* spp., formerly demonstrated only in bighorn sheep from Colorado, is now known from bighorn sheep of Alberta. Future research on the impact of lungworm infections upon individual or herds of bighorn sheep should consider this aspect of the parasite's life cycle.

## LITERATURE CITED

- Allen, D. M., and G. E. Lamming. 1961. Some effects of nutrition in the ewe. *J. Agr. Sci.* 56(1):69-79.
- Ammann, A. P., R. L. Cowan, C. L. Mothershead, and B. R. Baumgardt. 1973. Dry matter and energy intake in relation to digestibility in white-tailed deer. *J. Wildl. Manage.* 37(2):195-201.
- Association of Official Analytical Chemists. 1965. Official methods of analysis of the A.O.A.C. 10th edition. Washington.
- Bear, G. D., and G. W. Jones. 1973. Part one: History and distribution of bighorn sheep in Colorado. Fed. Aid Div. Final Rep. Colorado Div. of Wildlife. 232 pp.
- Brunsdon, R. V. 1964. III. The effect of nutrition on the establishment of trichostrongyle infestation. *N.Z. Vet. J.* 12:108-111.
- Blaxter, K. L. 1964. Utilization of the metabolizable energy of grass. *Proc. Nutr. Soc.* 23:62-70.
- Buechner, H. K. 1960. The bighorn sheep in the United States, its past, present, and future. *Wildl. Monogr.* 4.
- Buffo, J., L. J. Fritschen, and J. L. Murphy. 1972. Direct solar radiation on various slopes from 0 to 60 degrees north latitude. U.S.D.A. Forest Service Research Paper. PNW-142.
- Cable, R. M. 1958. An illustrated laboratory manual of parasitology. 4th edition. Burgess Co., Minneapolis, Minn. 165 pp.
- Chandler, A. C. 1953. The relation of nutrition to parasitism. *J. Egypt. Med. Ass.* 36:533-552.
- Couey, F. M. 1950. Rocky Mountain bighorn sheep of Montana. *Montana Fish and Game Comm. Bull. No. 2*, 90 pp.
- Cowan, I. M. 1962. Comments in R. L. Cowan — Physiology of nutrition as related to deer. Deer Disease Symposium Univ. Georgia, Athens, Ga.:8.
- Crofton, H. D. 1963. Nematode parasite population in sheep and on pasture. *Tech. Comm. 35*. Commonwealth Bureau of Helminthology. St. Albans, England.
- Davey, D. G. 1936. On the incidence of the abomasal parasites in the lambs of south-west Britain. *J. Helminthol.* 14(2):85.
- Demarchi, R. A. 1968. Chemical composition of bighorn winter forages. *J. Range Manage.* 21(6):385-388.
- Demarchi, R. A. and D. A. Demarchi. 1967. Status of the Rocky Mountain bighorn. *Wildl. Rev.* 4:10-13.

- Deo, P.G., K. C. Tandon, V. Kumar, and H. D. Srivastava. 1967. Studies on the effects of feeds deficient in trace elements, Vitamin A, protein, calcium and phosphorus on the natural resistance to the common liver fluke *Fasciola gigantica* Cobbald, 1855. *Indian J. Vet. Sci.* 37:351-359.
- Dineen, J. K. 1963. Immunological aspects of parasitism. *Nature* (London) 197:268-269.
- Dineen, J. K., and B. M. Wagland. 1966. The dynamics of the host-parasite relationship. V. Evidence for immunological exhaustion in sheep experimentally infected with *Haemonchus contortus*. *Parasitology* 56:665-677.
- Downey, N. E., J. F. Connolly, and J. O'Shea. 1972. Experimental ostertagiasis and the effect on resistance in sheep. *Irish J. Agric. Res.* 11(1):11-29.
- Evans, R. A., and R. M. Love. 1957. The step-point method of sampling — a practical tool in range research. *J. Rge. Manage.* 10(5):208-212.
- Ferguson, W. 1969. The role of social stress in epidemiology. *Brit. Vet. J.* 125(5):253-254.
- Forrester, D. J. 1969. Influence of weather on intensity of infection of bighorn sheep with lungworms of the genus *Protostrongylus*. *Abstr. 44th Annu. Meet. Am. Soc. Parasitol.* p. 40.
- Forrester, D. J. 1971. Bighorn sheep lungworm-pneumonia complex. Pages 158-173 in J. W. Davis and R. C. Anderson, eds. *Parasitic diseases of wild mammals*. Iowa State Univ. Press, Ames, Iowa. 364 pp.
- Forrester, D. J., and C. M. Senger. 1964a. Prenatal infection of bighorn sheep with protostrongylid lungworms. *Nature* 201:1051.
- Forrester, D. J., and C. M. Senger. 1964b. A survey of lungworm infection in bighorn sheep in Montana. *J. Wildl. Manage.* 28(3):481-491.
- Frye, W. W. 1955. Nutrition and intestinal parasitism. *Ann. New York Acad. Sci.* 63:175-185.
- Geist, V. 1971. *Mountain sheep: a study in behavior and evolution*. Univ. Chicago Press, Chicago. 383 pp.
- Gibson, T. E. 1963. The influence of nutrition on the relationships between gastrointestinal parasites and their hosts. *Proc. Nutr. Soc.* 22(1):15-20.
- Goldberg, A. 1965. Relation of feeding level to gastrointestinal nematode infection in cattle. *J. Parasitol.* 51(6):948-953.

- Gordon, H. McL. 1964. Studies on resistance to *Trichostrongylus colubriformis* in sheep. Influence of a quantitative reduction in the ration. Aust. Vet. J. 40(2):55-61.
- Graber, M. 1971. Role of diet in bovine and ovine fascioliasis caused by *Fasciola gigantica*. Bull. of Epizootic Dis. of Africa 19(1): 45-60.
- Hebert, D. M. 1973. Altitudinal migration as a factor in the nutrition of bighorn sheep. Ph.D. Thesis. Univ. of British Columbia, Vancouver. 357 pp.
- Hibler, C. P., R. E. Lange, and C. J. Metzger. 1972. Transplacental transmission of *Protostrongylus* sp. in bighorn sheep. J. Wildl. Dis. 8:389.
- Hibler, C. P., C. J. Metzger, T. R. Spraber, and R. E. Lange. 1974. Further observations on *Protostrongylus* sp. Infection by transplacental transmission in bighorn sheep. J. Wildl. Dis. 10:39-41.
- Highman, B., and P. O. Atland. 1964. Immunity and resistance to pathogenic bacteria at high altitudes. Pages 177-180 in W. H. Weihe, ed. The physiologic effects of high altitude. Oxford: Pergamon. 351 pp.
- Howe, D. L. 1965. Life cycle of lungworms. Fed. Aid Div. Quart. Rept. Wyo. Dept. of Game and Fish, p. 68.
- Hudson, R. J. 1970. Immunology of lungworm (*Protostrongylus*) infections of the Rocky Mountain bighorn sheep. Ph.D. Thesis. Univ. of British Columbia, Vancouver. 175 pp.
- Hudson, R. J. 1973. Moderated immunologic responsiveness in parasitic infections. Adv. Vet. Sci. and Comp. Med. 17:87-117.
- Hudson, R. J., W. D. Kitts, and P. J. Bandy. 1970. Monitoring parasite activity and disease in the Rocky Mountain bighorn by electrophoresis of seromuroids. J. Wildl. Dis. 6:104-106.
- Hudson, R., W. D. Kitts, and P. J. Bandy. 1971. Immunoglobulin response of the Rocky Mountain bighorn sheep. J. Wildl. Dis. 7:171-174.
- Hudson, R. J., P. J. Bandy, and W. D. Kitts. 1972. Cell adherence reactions in lungworm (*Protostrongylus*) infections of the Rocky Mountain bighorn sheep. Can. J. Comp. Med. 36:69-73.
- Hunter, G. C. 1953. Nutrition and host-helminth relationships. Nutr. Abstr. and Rev. 23:705-714.

- Johnston, A., and L. M. Bezeau. 1962. Chemical composition of range forage plants *Festuca scabrella* association. Can. J. Plant Sci. 42(1):105-115.
- Johnston, A. L., L. M. Bezeau, and S. Smoliak. 1968. Chemical composition and *in vitro* digestibility of alpine tundra plants. J. Wildlife Manage. 32(4):773-777.
- Kassai, T., and I. D. Aitken. 1967. Induction of immunological tolerance in rats to *Nippostrongylus brasiliensis* infection. Parasitology 57:403-418.
- Kauzal, G. 1934. Observations on the development of resistance to *Dictyocaulus filaria*. Aust. Vet. J. 10:100-111.
- Kleiber, M. 1961. Fire of life: an introduction to animal energetics. John Wiley and Sons, New York. 454 pp.
- Kloosterman, A., J. B. Hendriks, F. H. M. Borgsteede, and R. van den Brink. 1973. The influence of different feed and larval dose levels on experimental trichostrongylid infections in calves. Tijdschrift voor Diergeneeskunde 98(2):55-65.
- Lancaster, R. J. 1949. Estimation of digestibility of grazed pasture from feces nitrogen. Nature 163:330-331.
- Langlands, J. P., J. L. Corbett, and I. McDonald. 1963. The indirect estimation of the digestibility of pasture herbage. III. Regressions of digestibility on faecal nitrogen concentration: effects of species and individuality of animal and of the method of determining digestibility upon the relationships. J. Agr. Sci. 61:221-226.
- Laurence, G. B., J. W. Gruenwald, J. I. Quin, R. Clark, R. J. Ortlepp, and S. W. Bosman. 1951. The influence of nutritional level on verminosis in merino lambs. Onderstepoort J. Vet. Res. 25:121-132.
- Levine, N. D. 1963. Weather, climate and the bionomics of ruminant nematode larvae. Adv. Vet. Sci. 8:215-261.
- Lucker, J. T., and E. M. Newmayer. 1947. An experiment on the relationship of diet to hookworm disease in lambs. Amer. J. Vet. Res. 8:400.
- Marsh, H. 1938. Pneumonia in rocky mountain bighorn sheep. J. Mammalogy 19:214.
- McDevitt, H. O., and B. Benacerraf. 1969. Genetic control of specific immune responses. Advan. Immunol. 11:31-74.
- McLean, A., and E. W. Tisdale. 1960. Chemical composition of native forage plants in British Columbia in relation to grazing practices. Can. J. Plant Sci. 40(2):405-423.

- Millen, J. W. 1962. The nutritional basis of reproduction. C. T. Thomas, Springfield, Ill. 125 pp.
- Moen, A. N. 1973. Wildlife ecology. W. H. Freeman and Company, San Francisco. 458 pp.
- Monson, R. A., and G. Post. 1972. Experimental transmission of *Protostrongylus stilesi* to bighorn-mouflon sheep hybrids. J. Parasitol. 58(1):29-33.
- Montgomery, M. J., and B. R. Baumgardt. 1965. I. Pelleted rations varying in energy concentration. J. Dairy Sci. 48(5):569-574.
- Nathin, M. A. 1973. Interrelationships between host nutrition and parasitic infection. Paediatr. Inones 13(5):169-184.
- O'Donovan, P. B., R. F. Barnes, M. P. Plumlee, G. O. Mott, and L. V. Packett. 1967. "Ad libitum" intake and digestibility of selected reed canary grass (*Phalaris arundinacea* L.) clones, as measured by the fecal index method. J. Anim. Sci. 26(5):1144-1152.
- Ollerenshaw, C. B. 1966. The approach to forecasting the incidence of fascioliasis over England and Wales. Agr. Meteorol. 3(1/2):35-54.
- Pillmore, R. E. 1955. Investigations of the life history and ecology of the lungworm, *Protostrongylus stilesi*. Fed. Aid Div. Quart. Rept., Colo. Dept. Game and Fish. Pages 61-74.
- Pillmore, R. E. 1956. Investigations of the life history and ecology of the lungworm, *Protostrongylus stilesi*. Fed. Aid Div. Quart. Rept., Colo. Dept. of Game and Fish. Page 47.
- Pillmore, R. E. 1959a. Study of lung nematodes of bighorn sheep. Fed. Aid Quart. Rept., Colo. Dept. of Game and Fish. July:73-105.
- Pillmore, R. E. 1959b. The evidence for prenatal lungworm infection of bighorn lambs. J. Colo. Wyo. Acad. Sci. 4:61.
- Pillmore, R. E. 1961. Study of lung nematodes of bighorn sheep. Fed. Aid Div. Quart. Rept. Colo. Dept. of Game and Fish. Pages 69-97.
- Raymond, W. F. 1948. Evaluation of herbage for grazing. Nature 161:937-938.
- Robbins, C. T., A. N. Moen, and J. T. Reid. 1974. Body composition of white-tailed deer. J. Anim. Sci. 38(4):871-876.
- Rufi, V. G. 1961. Life cycle of lungworms. Fed. Aid Div. Quart. Rept. Wyo. Dept. of Game and Fish, p. 60.

- Sidkey, Y. A., J. S. Hayward, and R. F. Ruth. 1972. Seasonal variations of the immune response of ground squirrels kept at 22—24°C. *Can. J. Physiol. Pharmacol.* 50(3):203-206.
- Silver, H., N. F. Colvos, J. B. Holter, and H. H. Hayes. 1969. Fasting metabolism of white-tailed deer. *J. Wildl. Manage.* 33(3):490-498.
- Solomon, G. B. 1969. Host hormones and parasitic infections. *Int. Rev. Trop. Med.* 3:101-158.
- Stelfox, J. G. 1974. Range ecology of bighorn sheep in relation to self-regulation theories. A paper presented at the Northern Wild Sheep Council Meeting, April, 1974.
- Stone, W. H. 1956. The J substance of cattle. III. Seasonal variation of the naturally occurring isoantibodies for the J substance. *J. Immunol.* 77:369-376.
- Thompson, A. M., and W. Thompson. 1949. Lambing in relation to diet of the pregnant ewe. *Brit. J. Nutr.* 2(4):290-305.
- Thompson, C. B., J. B. Holter, H. H. Hayes, H. Silver, and W. E. Urban. 1973. Nutrition of white-tailed deer. I. Energy requirements of fawns. *J. Wildl. Manage.* 37(3):301-311.
- Thompson, W., and A. M. Thompson. 1953. Effect of diet on milk yield of the ewe and growth of her lamb. *Brit. J. Nutr.* 7(3):263-274.
- Uhazy, L. S., J. C. Holmes, and J. G. Stelfox. 1973. Lungworms in the Rocky Mountain bighorn sheep of western Canada. *Can. J. Zool.* 51(8):817-824.
- Verme, L. J. 1963. Effect of nutrition on growth of white-tailed deer fawns. Michigan Dept. of Conservation. Game Div. Rept. 2416.
- Viereck, E. G. 1963. Influence of cold on host-parasite interactions. Proc. Symp. Arctic Biol. Med. III. U.S. Dept. Commerce, Washington.
- Webster, A. J. F. 1970a. Environmental and physiological interactions influencing resistance to infectious disease. Pages 61-80 in R. H. Dunlop and H. W. Moon, eds. *Resistance to infectious disease.* Modern Press, Saskatoon. 311 pp.
- Webster, A. J. F. 1970b. Effects of cold outdoor environments on the energy exchanges and productive efficiency of beef cattle. University of Alberta, Dept. Animal Science Annual Feeders Day 49:30-34.
- Whitlock, J. H. 1958. The inheritance of resistance to trichostrongylidosis in sheep. I. Demonstration of the validity of the phenomenon. *Cornell Vet.* 48:127-133.



Wood, A. J., I. M. Cowan, and H. C. Nordan. 1962. Periodicity of growth in ungulates as shown by deer of the genus *Odocoileus*. *Can. J. Zool.* 40(4):593-603.

Yeates, N. T. M., and J. P. Parker. 1962. Effects of stress on reproduction. Pages 297-304 in E. S. E. Hafez, ed. *Reproduction in farm animals*. Lea and Febiger, Philadelphia, Pa. 367 pp.

Zulberti, C. A., and J. T. Reid. 1972. An equation, suitable for computer use, based on the ARC feeding system to determine the energy requirements of growing and fattening cattle. *Anim. Prod.* 14:17-23.