

**Exploring the Glycome of *Acinetobacter baumannii***

by

Robert Gerran Lees-Miller

A thesis submitted in partial fulfilment of all the requirements for the degree of

Master of Science

in

Microbiology and Biotechnology

Department of Biological Sciences

University of Alberta

Robert Gerran Lees-Miller, 2015 ©

## **Abstract**

*Acinetobacter baumannii* remains a poorly understood, but very dangerous opportunistic pathogen. Though it lacks clear virulence traits expected of pathogens, it none the less poses a massive threat to the hospital system due to its inherent and acquired resistance to antibiotics, survival on abiotic surfaces, and its ability to colonise almost any part of the body. We had previously set out to identify potential virulence factors and found protein *O*-glycosylation, a post-translational modification attaching oligosaccharides to proteins on the bacteria's surface. To elucidate the function and synthesis of this modification, we identify here a locus in the *A. baumannii* genome with all the necessary genes, as well as potentially linking the process of *O*-linked protein glycosylation with capsular polysaccharide synthesis, large polymers of sugar on the cell surface that protect from the immune system, antibiotics, and dessication. Using microscopy, protein and carbohydrate staining, and NMR we demonstrated that *A. baumannii* uses the same oligosaccharide for protein glycosylation and capsular polysaccharide through mutation of a critical enzyme, PglC, which transfers the first sugar to a lipid carrier in the membrane such that it can be used in later processes. We demonstrated that mutation of PglC caused drastic reductions in biofilm formation and virulence of this dangerous pathogen through serum killing assays and murine septicaemia challenges. The essential nature of this protein led us to further investigate its characteristics, and make progress in developing an *in vitro* assay that could be used to screen for potential inhibitors, with the end goal of developing new antibiotics. The diversity of *A. baumannii* glycans, and some initial observations lead us to investigate whether PglC may be promiscuous in its substrate preferences, which would be a radical departure from existing dogma surrounding this family of proteins. Through three *in vivo* models we provide preliminary evidence that this is the case, and that PglC substrate specificity can be modified through single amino acid substitutions. Taken together, we provide some necessary first steps in understanding and exploiting a new enzyme for biotechnology applications and a novel target for antibiotic development.

## **Preface**

The first half of this work was published in *Molecular Microbiology* Issue 89 (5) on July 12, 2013 under the title “A Common Pathway for O-Linked Protein-Glycosylation and Capsule in *Acinetobacter baumannii*” with contributions from: Jeremy A. Iwashkiw in the form of technical support, guidance, and bioinformatics work; Nichollas E. Scott in the form of all MS data and interpretation used in this study; Andrea Seper and Stefan Schild in the form of all biofilm flow-cell data and interpretation used in this study; Evgeny Vinogradov in the form of all NMR data and interpretation used in this study; Mario F. Feldman as the project's supervisor. Figures and methodological information for the first half are reproduced without modification.

All procedures and experiments involving animals (mice) were approved by the Institutional Animal Care Committee of Defence Research and Development Canada Suffield (protocol # CWS-08-1-1-1), and were in accordance with guidelines from the Canadian Council of Animal Care.

The second half of this work is unpublished, and original data.

## **Dedication**

The Word is only heard in silence,  
The Light shines only in darkness,  
The Dance is always danced above the hollow place,  
above the terrible abyss.

- Ged, Ursula K. Le Guin, *The Farthest Shore*

## **Acknowledgements**

This work was supported by grants from the Alberta Glycomics Centre and the Natural Sciences and Engineering Research Council (NSERC) to M. F. F. and by the Austrian Science Fund (FWF) grants: P229686 and W901 (DK Molecular Enzymology) to A. S. and S. S. We thank S. D. Kohlwein and H. Wolinski for access to the microscope facility, which is supported in part by the FWF project F3005-B12 LIPOTOX. M. F. F. is an Alberta Heritage Foundation for Medical Research (AHFMR) Scholar and a Canadian Institutes of Health Research (CIHR) new investigator. J. A. I. is an Alberta Innovates Health Solutions (AIHS) scholar. R. L. M. is an NSERC CGS-M recipient.

The generous contributions of plasmids by Michael Koomey (University of Oslo, Norway) for the kind gift of antibody UOS-2 and pEF33 plasmid, Markus Aebi (ETH, Zürich, Switzerland) for anti-CjLLO (HR6), Miguel A. Valvano (University of Western Ontario, Canada) for strains MSS2 and plasmid JD132, Chris Whitfield (University of Guelph, Canada) for *E. coli* O9 strains and antibodies.

The support and assistance of lab members past, especially Jeremy Iwashkiw, Eric de Haas, Vero Ielmini, Florencia Haurat, Matias Musumeci, and Nicolas Vozza; and current lab members Rachel Kinsella, Brent Weber, Wael Elhenawy, Mohamed Adel Nasr, Gerald Posch, Dominic Mills, Amy Ly, Josh Irwin, Dominic Mills, Ali Hajar, Nancy Price, and Mario Feldman for their support, guidance, and patience.

My supervisory committee, Mario Feldman, Christine Szymanski, Mark Glover, and external George Owtrim for their assistance, guidance, and time.

## Table of Contents

Abstract.....	ii
Preface.....	iii
Dedication.....	iv
Acknowledgements.....	v
Table of Contents.....	vi
List of Tables.....	vii
List of Figures.....	viii
Abbreviations.....	ix
Glossary of Terms.....	x
Body of Text.....	1
Manuscript 1: A Common Pathway for <i>O</i> -Linked Protein-Glycosylation and Capsule in <i>Acinetobacter baumannii</i> .....	2
Abstract.....	3
Introduction.....	4
Results.....	7
Identification of the <i>Acinetobacter baumannii</i> <i>O</i> -glycan Synthetic Cluster.....	7
A1S_0061 is an active initiator glycosyltransferase.....	8
PglC is required for capsule synthesis in <i>A. baumannii</i> ATCC 17978.....	9
PglC is necessary for survival in a human serum challenge.....	13
PglC is necessary for <i>O</i> -glycosylation.....	14
Capsular polysaccharide and the <i>O</i> -glycan share the same structure.....	15
Identification of <i>O</i> -Glycoproteins with deca-saccharide glycans.....	17
$\Delta$ <i>pglC</i> mutants are attenuated in a murine septicaemia model.....	18
Biofilm formation in $\Delta$ <i>pglC</i> is altered.....	19
Discussion.....	21
Materials and Methods.....	25
Manuscript 2: Characterising the Substrate Specificity of the <i>Acinetobacter baumannii</i> PglC Initiator Glycosyltransferase.....	36
Abstract.....	36
Introduction.....	37
Results.....	41
Building in vivo Models for Specificity.....	41
Structural Analysis of PglC.....	43
Site-Directed Mutagenesis.....	47
Development of an in vitro Assay.....	53
Discussion.....	57
Materials and Methods.....	60
Exploring the <i>Acinetobacter baumannii</i> Glycome: Conclusions.....	66
Bibliography.....	70

## List of Tables

Table 1.1. $^1\text{H}/^{13}\text{C}$ HSQC 2D NMR data.....	17
Table 2.1: Summary of site-directed mutant complementation.....	47
Table 2.2. Primers.....	63
Table 2.3. Strains and plasmids.....	64
Table 2.4. Sequences of iGTs.....	65

## List of Figures

Fig. 1.1. A genetic locus dedicated to glycan synthesis is present in <i>A. baumannii</i> ATCC 17978.....	8
Fig. 1.2. A1S_0061 is an iGT and complements mutation of <i>pglC</i> .....	9
Fig. 1.3. Mutation of <i>pglC</i> causes loss of protein glycosylation and capsule.....	11
Fig. 1.4. Capsule is not apparent in the $\Delta pglC$ mutant strain.....	12
Fig. 1.5. A <i>pglC</i> mutant strain is sensitive to complement-mediated killing.....	14
Fig. 1.6. Structure of the <i>A. baumannii</i> ATCC 17978 capsular polysaccharide.....	16
Fig. 1.7. A decasaccharide can be attached to glycoproteins in <i>A. baumannii</i> ATCC 17978.....	18
Fig. 1.8. Biofilms of <i>A. baumannii</i> $\Delta pglC$ .....	20
Fig. 1.9. Proposed model for the bifurcated pathway.....	22
Fig. 1.S1. Proposed pathway for the synthesis of GlcNAc3NAcA4OAc.....	32
Fig. 1.S2. PAS stain of extracted capsule.....	32
Fig. 1.S3. Mutation of A1S_0061 does not affect LOS.....	33
Fig. 1.S4. Survival of <i>A. baumannii</i> strains in 100% horse serum.....	34
Fig. 1.S5. Growth of <i>A. baumannii</i> ATCC 17978.....	35
Figure 2.1. Complementation of in vivo models.....	42
Figure 2.3. Site-directed mutagenesis plan for PglC.....	46
Figure 2.4. Complementation of in vivo models by site-directed mutants.....	50
Figure 2.5. Expression of PglC mutants in the in vivo complementation models.....	52
Figure 2.6. ClustalO alignment of four <i>A. baumannii</i> PglC proteins.....	53
Figure 2.7. Schematic for in vitro PglC activity assay.....	54
Figure 2.8. Purification of the PyrH nucleoside monophosphate kinase.....	55
Figure 2.9. Results of in vitro PyrH activity using luminescence from ADP-Glo.....	56



## **Abbreviations**

- CPS: Capsular polysaccharide
- iGT: Initiator glycosyltransferase
- GlcNAc/GalNAc: *N*-acetylglucosamine / *N*-acetylgalactosamine
- diNAcBac: di-*N*-acetylbacillosamine
- UndP: Undecaprenylphosphate
- MDR: Multi-drug resistant
- NMR: Nuclear magnetic resonance
- PNPTs: Polyisoprenylphosphate *N*-acetylaminosugar-1-P Transferases
- PHPTs: Polyisoprenylphosphate Hexose-1-P Transferases
- TM: Transmembrane
- LOS/LPS: Lipooligosaccharide/lipopolysaccharide
- XDP: Nucleotide diphosphate
- ZIC-HILIC: Zwitterionic hydrophilic interaction chromatography
- CAZy: Carbohydrate Active Enzyme Database

## **Glossary of Terms**

- Protein *O*-Glycosylation: The covalent attachment of mono or oligosaccharides to serine or threonine residues on proteins.
- Epimerase: Proteins catalysing the epimerisation of sugar molecules

Body of Text

# Manuscript 1: A Common Pathway for O-Linked Protein-Glycosylation and Capsule in *Acinetobacter baumannii*

Robert G. Lees-Miller<sup>1</sup>, Jeremy A. Iwashkiw<sup>1</sup>, Nichollas E. Scott<sup>2</sup>, Andrea Seper<sup>3</sup>, Evgeny Vinogradov<sup>4</sup>, Stefan Schild<sup>3</sup>, and Mario F. Feldman<sup>1\*</sup>

1 Alberta Glycomics Centre, Department of Biological Sciences, University of Alberta, CW405 Biological Sciences Building, Edmonton, Alberta, Canada T6G 2E9. 2 Centre for High-Throughput Biology, University of British Columbia, Vancouver, British Columbia, Canada V6T 1Z4. 3 Institut fuer Molekulare Biowissenschaften, Karl-Franzens-Universitaet Graz, Humboldtstrasse 50, 8010 Graz, Austria. 4 Institute for Biological Sciences, National Research Council, 100 Sussex Drive, Ottawa, ON, Canada K1A 0R6.

Figures and some technical text are published in *Molecular Microbiology* on 12 July 2013 Issue **89**(5), pages 816-830 with the same title (Lees-Miller et al. 2013) and are used here without modification.

Significant contributions were made by Jeremy A. Iwashkiw in the form of technical support, guidance, and bioinformatics work. By Nichollas E. Scott in the form of all MS data and interpretation used in this study. By Andrea Seper and Stefan Schild in the form of all biofilm flow-cell data and interpretation used in this study. By Evgeny Vinogradov in the form of all NMR data and interpretation used in this study. By Mario F. Feldman as the project's supervisor.

## ***Abstract***

Multi-drug resistant strains of *Acinetobacter baumannii* are increasingly being isolated in hospitals worldwide. Among the virulence factors identified in this bacterium there is a general *O*-glycosylation system that appears to be important for biofilm formation and virulence, and the capsular polysaccharide, which is essential for resistance to complement killing. In this work, we identified a locus that is responsible for the synthesis of the *O*-pentasaccharide found on the glycoproteins. Besides the enzymes required for the assembly of the glycan, additional proteins typically involved in polymerization and transport of capsule were identified within or adjacently to the locus. Mutagenesis of PglC, the initiating glycosyltransferase prevented the synthesis of both glycoproteins and capsule, resulting in abnormal biofilm structures and attenuated virulence in mice. These results, together with the structural analysis of *A. baumannii* 17978 capsular polysaccharide via NMR, demonstrated that the pentasaccharides that decorate the glycoproteins are also the building blocks for capsule biosynthesis. Two linked subunits, but not longer glycan chains, were detected on proteins via MS. The discovery of a bifurcated pathway for *O*-glycosylation and capsule synthesis not only provides insight into the biology of *A. baumannii* but also identifies potential novel candidates for intervention against this emerging pathogen.

## ***Introduction***

*Acinetobacter baumannii* has become an increasingly concerning pathogen in the hospital environment due to its antibiotic, desiccation, and disinfectant resistance (Peleg, Seifert, and Paterson 2008). This Gram-negative, opportunistic, nosocomial pathogen has a high mortality rate, approaching 50% (Gaynes and Edwards 2005), and causes disease mostly in immuno-compromised and burn patients resulting in soft-tissue infections, pneumonia, septicemia, urinary tract infections, and meningitis (Gordon and Wareham 2010). While it has been known in the hospital system since the early 1970s (Bergogne-Bérézin and Towner 1996), its prevalence exploded in the early 2000s, partially due to Operation Iraqi Freedom (Murray et al. 2008). Since then, MDR phenotypes have risen exponentially, with over 70% of isolates being reported as MDR in 2012 (Kempf and Rolain 2012). Horizontal gene transfer and natural competence have contributed to this rise in antibiotic resistance (Adams et al. 2008). Despite its rising status, it has few identified virulence factors (Imperi et al. 2011), and these have not been clearly linked to the rise or fall of specific strains (Smith et al. 2007; Antunes, Visca, and Towner 2013). *A. baumannii* represents then a new kind of pathogen threat, capable of causing disease simply due to its incredible defence mechanisms and survival strategies, many of which derive from its uses of carbohydrates, with capsular polysaccharides (Russo et al. 2010), poly-*N*-acetylglucosamine (Choi et al. 2009), lipooligosaccharide (Luke et al. 2010; Mortensen and Skaar 2012), and *O*-linked protein glycosylation (J A Iwashkiw et al. 2012) having been identified as critical virulence factors.

Of these *A. baumannii* virulence factors, *O*-linked and capsular polysaccharide pathways are notable as they can both proceed through the *en bloc* synthesis pathway (Whitfield 2006; Hug and Feldman 2011). Both are initiated at the cytoplasmic face of the inner membrane through the action of an initiator glycosyltransferase (iGT) that attaches a nucleotide activated sugar to the

undecaprenylphosphate lipid carrier (Hug and Feldman 2011). Subsequent glycosyltransferases add additional sugars to create the full oligosaccharide building block, which is then flipped to the periplasm through the action of a flippase (Hug and Feldman 2011). It is at this point that the two pathways diverge, with the oligosaccharide subunits being directly attached to their protein targets by the *O*-oligosaccharyltransferase, such as PglL (Faridmoayer et al. 2007). Capsular polysaccharide is formed by the polymerisation of these subunits and their subsequent export to the cell surface (Whitfield 2006) (Fig. 1.9).

Many bacteria possess multiple surface carbohydrates, including cases where they will use the same undecaprenylphosphate carrier for multiple purposes, and separate their uses chemically and spatially. Three illustrative examples are *C. jejuni*, *E. coli* O9:K30, and *Pseudomonas aeruginosa*. *C. jejuni*, utilises processive, *wzy*-independent glycosylation pathways for its *O*-glycans, not requiring undecaprenylphosphate (Nothaft and Szymanski 2010), and uses different chemical steps to reduce possible interference from similar sugars used in its *N*-glycans (Schoenhofen et al. 2009). Similarly, its LOS and CPS are produced processively, without a polymerised *O*-antigen (Moran and Penner 1999; Karlyshev et al. 2002). This leaves only *N*-glycosylation (Szymanski and Wren 2005) and peptidoglycan synthesis to use the undecaprenylphosphate carrier and are separated by the specificity of their transfer enzymes. *E. coli* O9:K30 uses *en bloc* synthesis for producing its LPS *O*-antigen and the K-antigen capsular polysaccharide (Drummelsmith and Whitfield 1999), and differentiates between the two through sequestration of the K30 polymer by *wza*, the CPS export protein, immediately after its polymerisation. *Pseudomonas aeruginosa* uses the same subunit for its *O*-antigen and *O*-glycosylation (DiGiandomenico et al. 2002). Here the separation is mediated by the oligosaccharyltransferase, which can not transfer polymers (Faridmoayer et al. 2007).

To target the synthesis pathway for *A. baumannii* ATCC 17978 O-glycosylation we searched for the synthesis genes of a unique tri-acetylated glucuronic acid (GlcNAc3NAcA4OAc) identified in the glycan through nuclear magnetic resonance (NMR) analysis (J A Iwashkiw et al. 2012). Thus far di-acetylated hexuronic sugars have only been described in *Bordetella pertussis* and *Pseudomonas aeruginosa*, and to our knowledge tri-acetylation is unique (Knirel and Kochetkov 1994; Westman et al. 2008). The genes necessary for producing di-acetylated mannuronic acid (ManNAc3NAcA) in *Pseudomonas aeruginosa* are the WbpABDEI genes (Rocchetta, Burrows, and Lam 1999). WbpABDE function to modify nucleotide activated GlcNAc to GlcNAc3NAcA (Miller et al. 2004; Wenzel et al. 2005; Larkin and Imperiali 2009), which is then epimerised to ManNAc3NAcA by WbpI (Westman et al. 2007) (Fig. 1.S1).

A cluster of genes homologous to the Wbp genes necessary for producing the GlcNAc3NAcA4OAc sugar were identified in close proximity to a sufficient number of glycosyltransferases to create the full pentasaccharide observed on *A. baumannii* glycoproteins (J A Iwashkiw et al. 2012). Interestingly, there were also genes encoding a capsular polysaccharide synthesis pathway, and the initiator glycosyltransferase, A1S\_0061, was the only initiator we could identify. This led us to hypothesise that *A. baumannii* is using the same pentasaccharide for both its glycoproteins and capsular polysaccharide. To test this we developed a mutant in A1S\_0061 and tested its effects on protein glycosylation, capsular polysaccharide synthesis, and virulence.



## Results

### Identification of the *Acinetobacter baumannii* O-glycan Synthetic Cluster

The identification of GlcNAc3NAcA4OAc in previous work (J A Iwashkiw et al. 2012) was used to identify synthetic genes through BLAST searching of the *A. baumannii* ATCC 17978 genome for genes homologous to the *wbp* genes of *Pseudomonas aeruginosa* and *wdl* genes of *Bordetella pertussis* that form a similar, double-acetylated mannuronic acid in these bacteria (Westman et al. 2008; Larkin and Imperiali 2009). A cluster of genes was identified, A1S\_0052-A1S\_0057, sufficient to produce GlcNAc3NAcA4OAc (Fig. 1.1, Fig. 1.S1). The cluster also contained a *wzx* flippase, necessary for transferring cytoplasmic synthesised glycans to the periplasm, leading us to examine neighbouring genes that may contribute to *en bloc* synthesis. Doing so we were able to identify a sufficient number of glycosyltransferase homologues to construct the full pentasaccharide: A1S\_0058, A1S\_3482, A1S\_0059, A1S\_0060, and an initiator glycosyltransferase homologue A1S\_0061. Additional gene homologues for sugar modification and UDP-activation were also identified (A1S\_0062 – A1S\_0066) (Fig. 1.1). Based on these we hypothesised that this cluster of genes was responsible for O-glycan synthesis. Interspersed within and adjacent to this cluster were also a series of genes homologous to *wzy*-dependent Type 1 capsular polysaccharide synthesis genes: *wzc* (A1S\_0049), *wzb* (A1S\_0050), *wza* (A1S\_0051), and *wzy* (A1S\_3483) (Fig. 1.1). The final component, *wzi*, thought to be responsible for attachment of the CPS to the cell surface (Bushell et al. 2013) was identified elsewhere (A1S\_0999). Searching for other initiator glycosyltransferases, we were unable to identify other potential synthesis clusters, and based on the genetic proximity of the CPS and O-glycosylation clusters as well, we hypothesised that this cluster of genes was responsible for synthesising the oligosaccharide used in both systems. The importance of both to virulence has previously been identified, but not any linkage (J A Iwashkiw et al. 2012; Russo et al. 2010).

In parallel to our discovery of this cluster, another group also identified that it is highly

conserved across *A. baumannii* strains in terms of its general architecture, though the specific glycosyltransferases and accessory genes vary widely (Kenyon and Hall 2013).

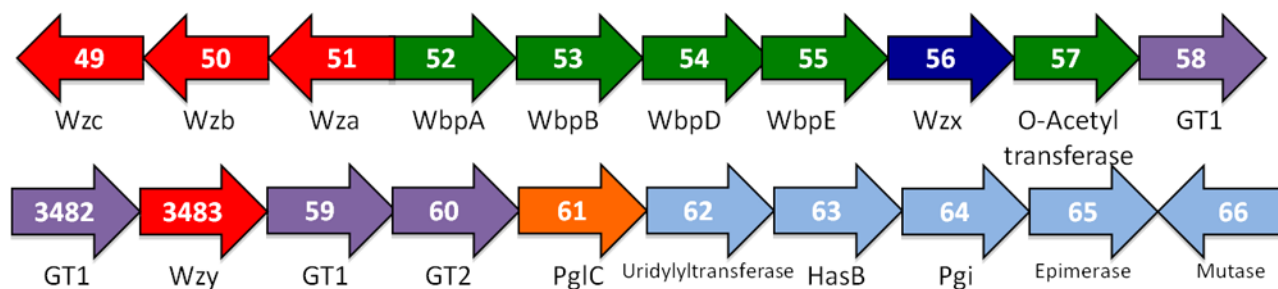

Fig. 1.1. A genetic locus dedicated to glycan synthesis is present in *A. baumannii* ATCC 17978. The locus appears to contain genes required for O-glycosylation and *wzy*-dependent capsule synthesis. Genes were annotated with gene names or functions identified by homology through BLAST searches. GT1 and GT2 are the CAZy designation of the hypothetical glycosyltransferase genes, but it is not entirely clear which specific transfer reactions they catalyze. Colours correspond to: Capsule synthesis (red), GlcNAc<sub>3</sub>NAcA<sub>4</sub>OAc synthesis (green), flippase (dark blue), glycosyltransferases (purple), iGT (orange), and associated genes (blue). Not to scale, arrow direction is orientation within the genome, numbers in arrows represent ORF annotation.

### A1S\_0061 is an active initiator glycosyltransferase

For *en bloc* glycan synthesis to occur in the cytoplasm and be utilised in the periplasm, the sugars are built on the undecaprenylphosphate lipid carrier and the attachment of the first sugar is mediated by an initiator glycosyltransferase (Bugg and Brandish 1994). A1S\_0061 was the only iGT identifiable by homology, and was closest to the PglC of *Campylobacter jejuni*, involved in *N*-glycosylation transferring di-*N*-acetylbacillosamine (Glover et al. 2006). To verify the function of A1S\_0061 as an iGT, we used a *C. jejuni* heptasaccharide synthesis pathway reconstituted in *E. coli*. The gene cluster expressed on pACYCpgl is capable of producing the *C. jejuni* heptasaccharide in *E. coli* and using the native WaaL O-antigen ligase to attach it to the lipid A (Fry et al. 1998; Wacker et al. 2002). Transposon mutagenesis of the *pglC* in this cluster abolishes heptasaccharide production (Linton et al. 2005) and the CLM 37 *E. coli* *wecA*- background is used to prevent any possibility of

complementation by *WecA*, the native *E. coli* iGT for O-antigen and Enterobacterial Common Antigen synthesis. A 6x-His tagged version of A1S\_0061 was cloned and expressed in the pACYCΔ*pglC* strain and lipid A-linked *C. jejuni* heptasaccharide was detected by silver staining (Fig. 1.2A) and Western-blot with the HR6 antibody (Fig. 1.2B). A1S\_0061 was capable of fully restoring heptasaccharide production, indicating that it is an active iGT. Based on homology to the *C. jejuni* homologue, we named it PglC.

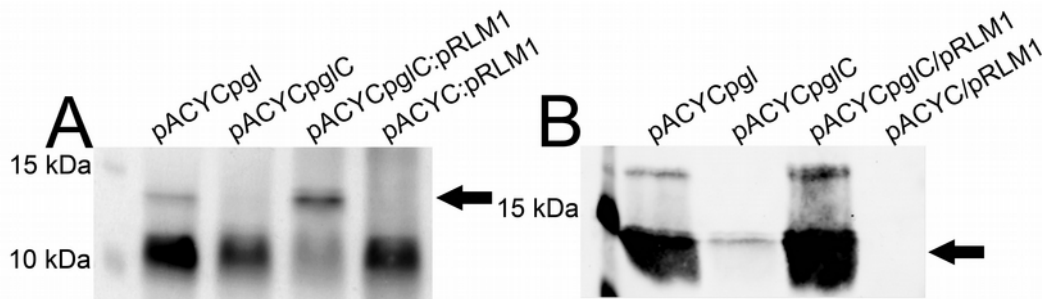

Fig. 1.2. A1S\_0061 is an iGT and complements mutation of *pglC* in the *pgl* heptasaccharide synthesis cluster of *C. jejuni* expressed in the CLM37 *wecA*- mutant strain of *E. coli*. (A) LPS was extracted by the hot phenol method (Marolda et al. 1990) and run on 8% SDS-PAGE before visualisation by silver staining. Black arrow indicates LPS modified with the heptasaccharide as determined by electrophoretic mobility in strains expressing the pACYCpgl plasmid (lane 1); pACYCpglC mutant plasmid (lane 2), and pRLM1 containing A1S\_0061 (lane 3); or the vector pACYC and pRLM1 (lane 4). (B) Western blot of LPS extractions using the HR6 anti-*Cj* heptasaccharide antibody. Black arrow corresponds to heptasaccharide visible in (A). Strains were reinoculated from overnight culture to approximately  $1 \text{ OD}_{600\text{mL}^{-1}}$  and induced with IPTG for four hours before extraction.

### **PglC is required for capsule synthesis in *A. baumannii* ATCC 17978**

To test our hypothesis that the O-glycan cluster was shared with CPS, we developed an unmarked deletion mutant of *pglC* in *A. baumannii* ATCC 17978 using homologous recombination mutagenesis. Mutation of *pglC* was not detrimental to growth as determined by a growth curve compared to wildtype, nor did it have noticeable effects on protein expression as determined by

Coomassie stains of SDS-PAGE separated membrane fractions (data not shown). Our first step in identifying the mutant phenotype was using a periodic acid-Schiff (PAS) stain for carbohydrates on SDS-PAGE separated membrane fractions from wildtype. *pglL*, *pglC* mutants (Fig. 1.3A) that had previously been used to identify *O*-glycosylation in *A. baumannii* (J A Iwashkiw et al. 2012). Four moieties are PAS reactive in the wildtype: very high-molecular weight poly-*N*-acetylglucosamine that does not fully enter the separating gel (Choi et al. 2009), a high-molecular weight band (>200 kDa, black bar Fig 1.3A) associated with CPS by antibody staining (Russo et al. 2010) and by CPS purification (Fig. 1.S2); a Proteinase K sensitive band (25-35 kDa, arrow Fig. 1.3A) associated with *O*-glycoproteins (J A Iwashkiw et al. 2012); and a low molecular weight band (<20 kDa) expected to be LOS, as *A. baumannii* ATCC 17978 lacks an O-antigen ligase required for LPS production. Knockouts in *pglL*, the *O*-glycosylation oligosaccharyltransferase that mediates the attachment to proteins predictably lost only the *O*-glycoprotein band (J A Iwashkiw et al. 2012). The *pglC* knockout lost both the CPS and *O*-glycoprotein bands, and was complemented by *in trans* expression of PglC on the pRLM2 vector (Fig. 1.3A). LOS was unaffected by either mutation (Fig 1.S3), consistent with its production being independent of *en bloc* oligosaccharide synthesis.

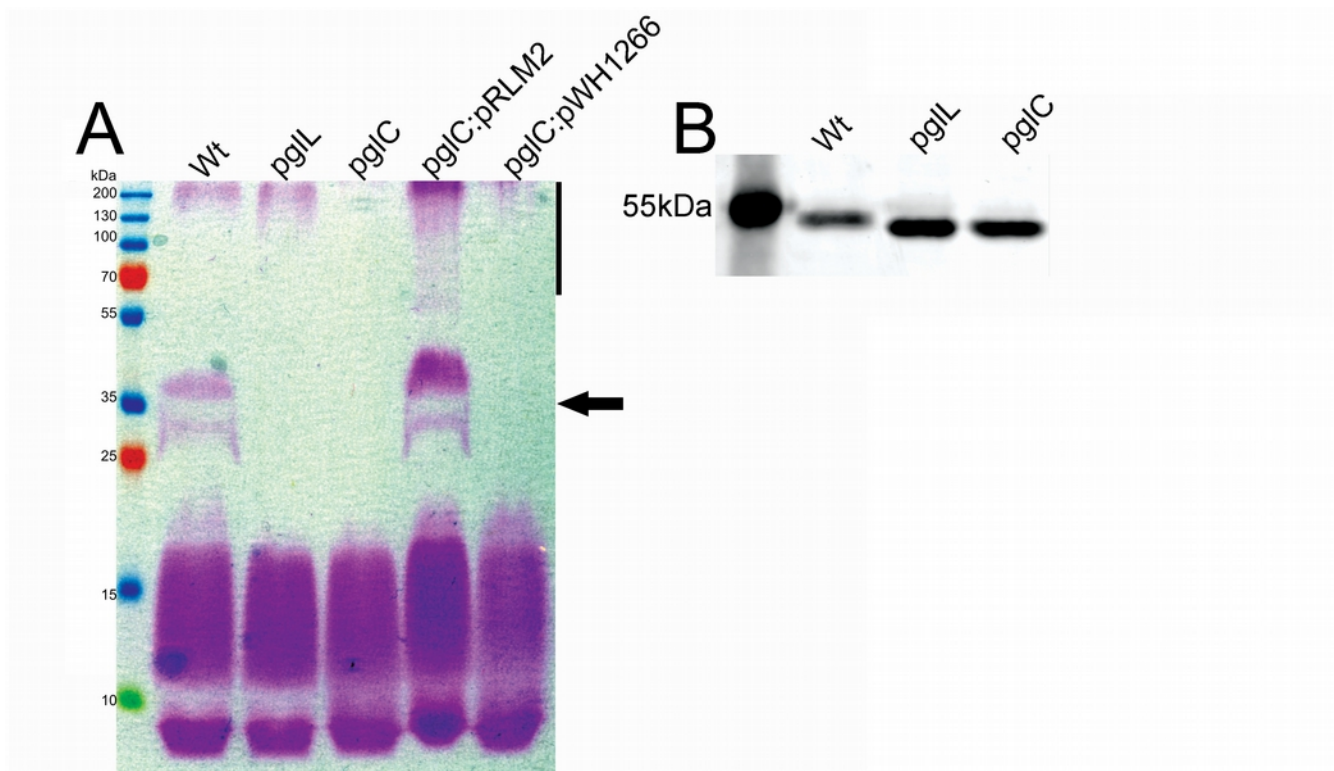

Fig. 1.3. Mutation of *pgIC* causes loss of protein glycosylation and capsule. (A) Membrane extracts standardized by Bradford assay according to protein concentration were separated on 12% SDS-PAGE and cis-diol sugars were visualised by PAS stain. *A. baumannii* ATCC 17978 wildtype has two distinct sugar containing bands, corresponding to the capsule (bar) and glycoprotein (arrow).  $\Delta pgIL$  and  $\Delta pgIC$  lack the band corresponding to glycoproteins.  $\Delta pgIC$  also shows loss of the capsule. Expression of *pgIC* in trans restores the wild-type phenotype. (B) Western blot of whole cell samples of strains expressing OmpA1193-10xHis. Increased electrophoretic mobility of the anti-His reactive band in  $\Delta pgIC$  and  $\Delta pgIL$  is indicative of a loss of glycosylation.

To confirm that CPS was affected by *pgIC* deletion, we used light microscopy with an Alcian Blue/Safranin Red stain to visualise negatively charged sugars such as the GlcNAc3NAcA4OAc terminal sugar blue with Alcian Blue 8GX (Sigma) (Hendley et al. 1981), with Safranin providing counter-stain. Wt bacteria appear blue (Fig. 1.4A), while *pgIC* mutants appear red, consistent with only being visible by counter-stain (Fig. 1.4B), and this deficiency can be complemented by expression of PglC on pRLM2 (Fig. 1.4C). Mutants in *pgIL* still stain blue, indicating that staining is independent

of O-glycoproteins (Fig. 1.4D). This provides additional evidence that PglC is involved in CPS production in *A. baumannii*.

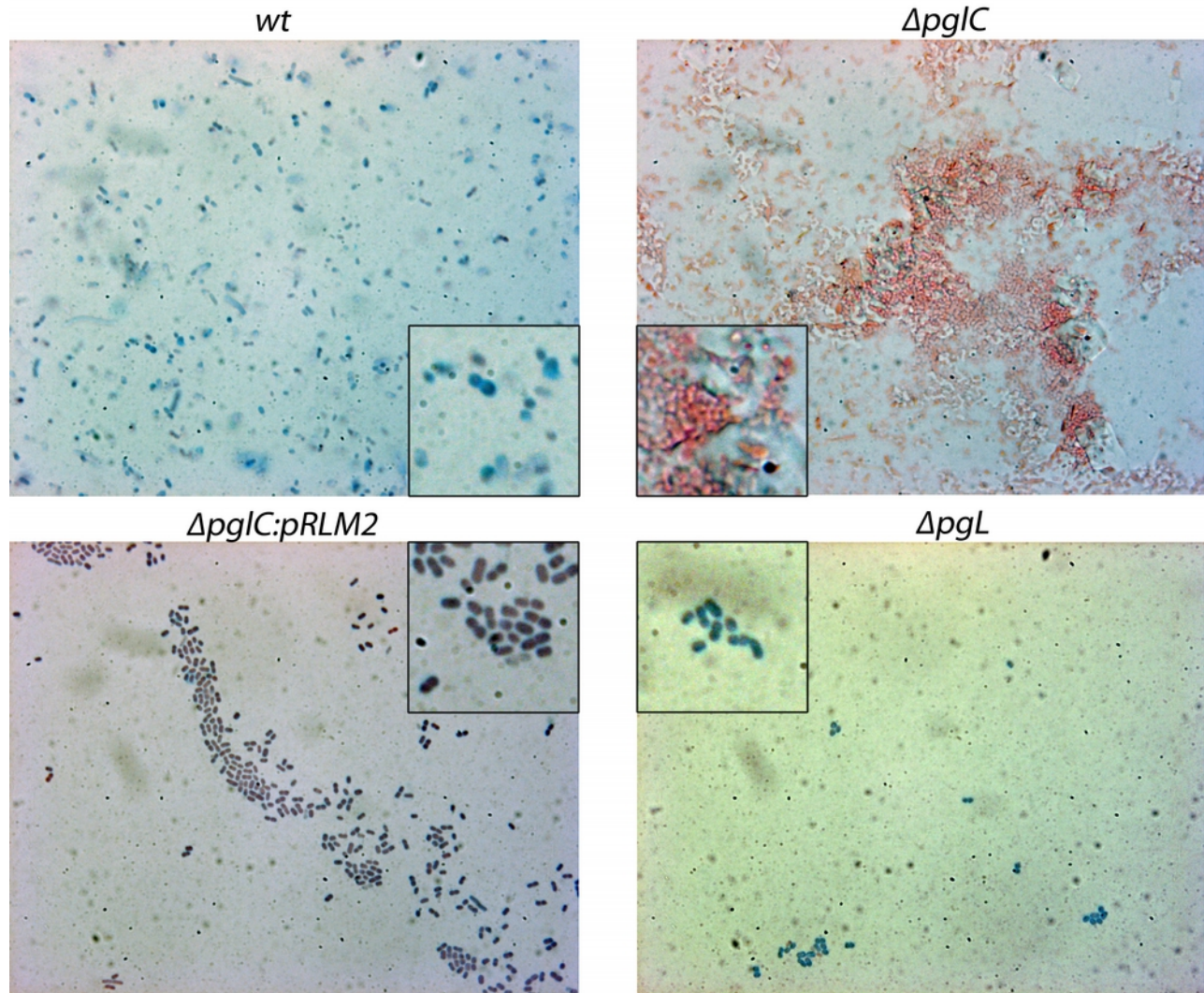

Fig. 1.4. Capsule is not apparent in the  $\Delta pglC$  mutant strain. Capsule is visualised by Alcian Blue/Safranin staining of *A. baumannii* cells at 1000x magnification. Insets in black squares show representative bacteria. From top left: (wt) *A. baumannii* ATCC 17978. ( $\Delta pglC$ ) *A. baumannii* ATCC 17978  $\Delta pglC$ . ( $\Delta pglC:pRLM2$ ) *A. baumannii* ATCC 17978  $\Delta pglC:pRLM2$ . ( $\Delta pglL$ ) *A. baumannii* ATCC 17978  $\Delta pglL$ . Cells were grown directly on glass coverslips for 4 h at room temperature before fixation and staining with Alcian Blue for negatively charged surface sugars, and Safranin red as a counter-stain.

## **PglC is necessary for survival in a human serum challenge**

One of the primary purposes of CPS in general is protection from complement mediated killing, an innate immune response to bacterial infections, and *A. baumannii* depends on its capsule for protection from serum (Umland et al. 2012). To verify our molecular evidence for CPS production being dependent on PglC we used serum survival to test for the presence of a protective capsule. Strains were mixed with 100% human serum for 3 hours at 37°C then spotted on LB in serial dilutions and grown overnight to determine survival rates. Wildtype *A. baumannii* survived incubation in serum (Fig. 1.5), and  $\Delta pglC$  was killed entirely (Fig. 1.5). Survival was restored by expression of PglC from the pRLM2 plasmid. Glycoproteins were not necessary for serum survival (Fig. 1.5), and growth of  $\Delta pglC$  in heat-inactivated serum demonstrated that killing was due to protein factors, not nutritional limitations. We also tested horse serum, as it is more economical, and *A. baumannii* was shown to also infect horses (Abbott et al. 2005), and achieved similar results (Fig. 1.S4).

The combination of PAS, Alcian Blue, and serum survival analyses provides compelling evidence that *A. baumannii* ATCC 17978 depends on PglC for the synthesis of its CPS.

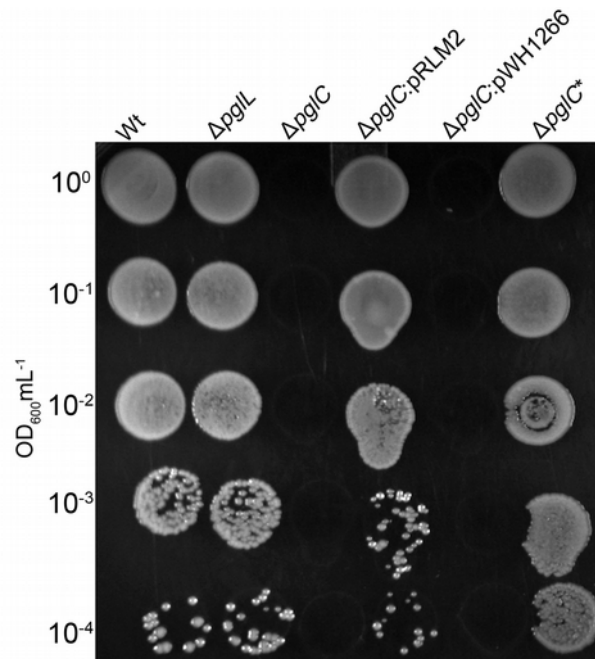

Fig. 1.5. A *pglC* mutant strain is sensitive to complement-mediated killing. Survival of strains after 3 h incubation at 37°C in human complement serum: wt (lane 1),  $\Delta pglL$  (lane 2),  $\Delta pglC$  (lane 3),  $\Delta pglC:pRLM2$  (lane 4),  $\Delta pglC:pWH1266$  (lane 5), in 100% serum; and  $\Delta pglC$  in heat-inactivated serum (lane 6). Inoculums were serially diluted from 1  $OD_{600}mL^{-1}$  (Row 1) to  $1 \times 10^{-4} OD_{600}mL^{-1}$  (Row 5) in serum. 10  $\mu L$  were spotted in duplicate on LB agar to estimate bacterial concentration. Heat-inactivated serum has been heated at 56°C for 10 minutes to inactivate protein factors.

### **PglC is necessary for O-glycosylation**

To confirm the loss of O-glycosylation seen in the PAS stain, we expressed a 10xHis tagged version of a naturally glycosylated *A. baumannii* protein, OmpA-1193, in the wildtype and each mutant strain. Whole cell samples were separated by SDS-PAGE and using an anti-10xHis antibody we examined OmpA-1193 for shifts in electrophoretic mobility that would be consistent with modification by the pentasaccharide (Fig. 1.3B). In both the  $\Delta pglL$  and  $\Delta pglC$  strains OmpA-1193 had increased electrophoretic mobility compared to the wildtype, consistent with a loss of glycosylation. We also



used an MS approach for enrichment and detection of glycopeptides, Zwitterionic hydrophilic interaction chromatography (ZIC-HILIC), which had previously been used to consistently and reliably detect glycopeptide fragments for 7 glycoproteins in trypsinised *A. baumannii* membrane protein samples (J A Iwashkiw et al. 2012). ZIC-HILIC MS of  $\Delta pglC$  samples yielded no glycopeptides.

Taken together, the PAS, electrophoretic shift, and MS results strongly support the hypothesis that PglC is required for O-linked protein glycosylation in *A. baumannii* ATCC 17978.

### **Capsular polysaccharide and the O-glycan share the same structure**

Unequivocal proof of the linking of the two pathways through the synthesis of a common pentasaccharide subunit was demonstrated by the purification and NMR analysis of *A. baumannii* ATCC 17978 capsular polysaccharide. The structure of the CPS repeating unit was identified as the same pentasaccharide previously identified on O-glycoproteins (J A Iwashkiw et al. 2012), linked by a Glc $\alpha$ 3  $\rightarrow$  1GalNAc glycosidic bond, leaving the GlcNAc3NAcA4OAc and terminal GlcNAc as branches (Fig. 1.6, Table 1.1).

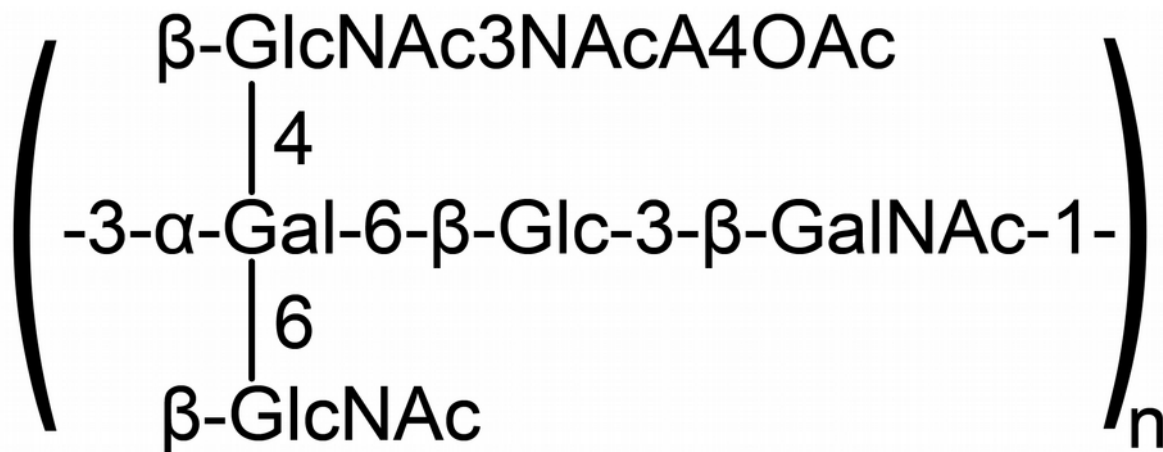

Fig. 1.6. Structure of the *A. baumannii* ATCC 17978 capsular polysaccharide as determined by NMR. Repeat units are connected through a Glc $\alpha$ 3 $\rightarrow$ 1GalNAc linkage with GlcNAc3NAcA4OAc and GlcNAc as branches.

---

Unit		H/C-1	H/C-2	H/C-3	H/C-4	H/C-5	H/C-6a;b
Gal A	H	4.93	3.72	3.90	4.35	4.05	3.72; 4.07
	C	99.2	68.5	81.7	78.1	70.6	72.3
GlcNNA4Ac B	H	5.09	3.83	4.03	4.97	4.06	
	C	102.5	54.5	55.8	72.0	75.2	
GlcNNA B'	H	5.06	3.95	4.23	3.64	3.96	
	C	102.6	54.1	53.8	71.4	77.5	
GalNAc C	H	4.62	4.15	3.87	4.16	3.71	3.84
	C	104.9	52.6	81.7	69.1	75.9	62.4
Glc D	H	4.57	3.32	3.49	3.61	3.61	3.65; 3.99
	C	106.1	74.1	76.8	70.0	75.4	65.8
GlcNAc E	H	4.48	3.69	3.54	3.46	3.45	3.78; 3.93
	C	103.0	56.7	75.2	71.0	76.9	61.9

Table 1.1.  $^1\text{H}^{13}\text{C}$  HSQC 2D NMR data for the characterization of the *A. baumannii* 17978 capsular polysaccharide

---

### Identification of O-Glycoproteins with deca-saccharide glycans

The utilisation of the same oligosaccharide for CPS and O-glycoproteins poses a challenge for bacteria in preventing the addition of long polysaccharides to glycoproteins. To examine how *A. baumannii* regulates glycan length we revisited previous MS data, looking for larger polymers present in trypsinised, ZIC-HILIC enriched *A. baumannii* membrane proteins. We were able to identify a modification of the “AKPASTPAVK” peptide belonging to the A1S\_0556 glycoprotein modified with a deca-saccharide composed of two repeats of the pentasaccharide (Fig. 1.7). No glycans longer than this were identified. While it is not conclusive to either a spatial restriction or substrate specificity of the PglL, it does demonstrate that whatever control is potentially leaky.

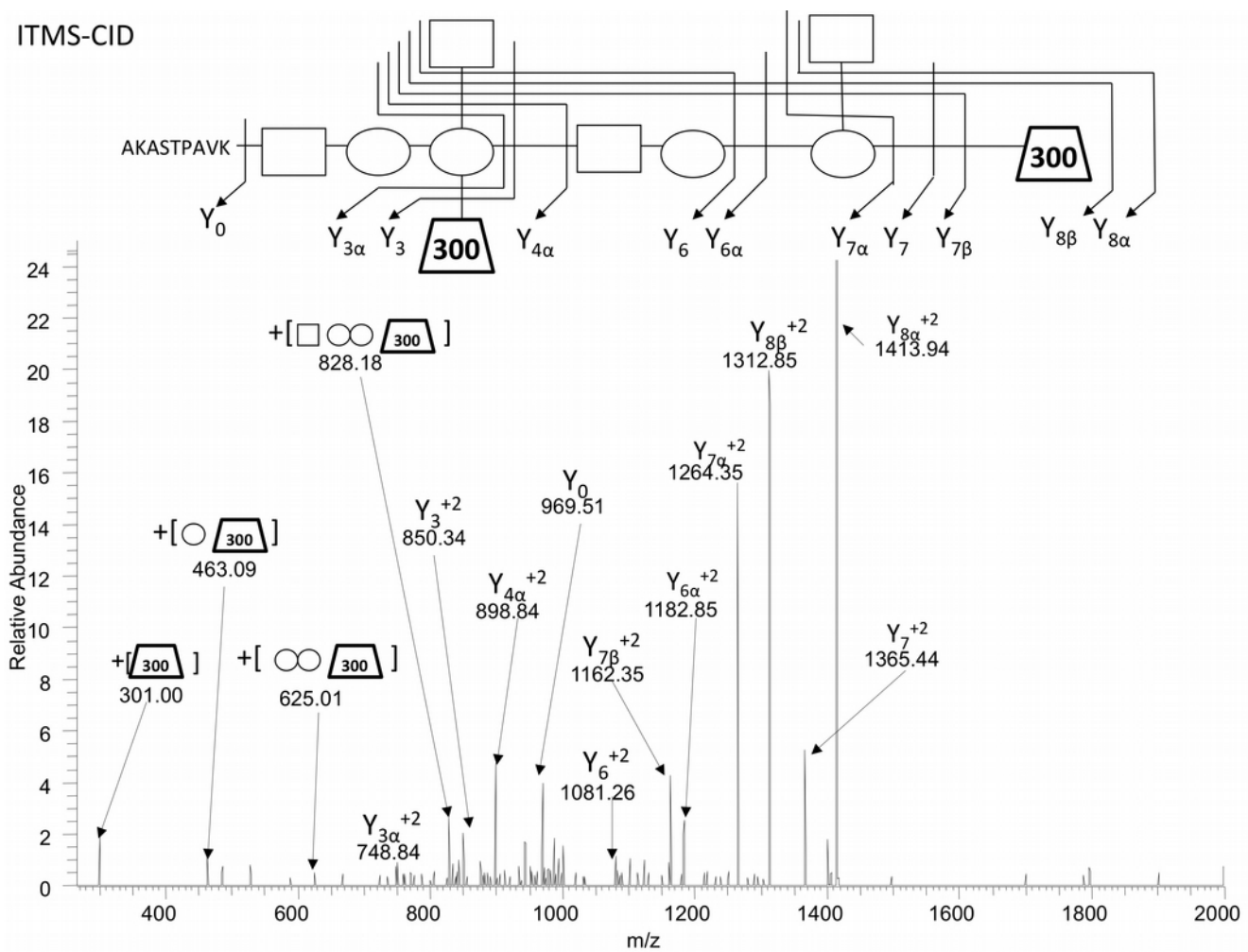

Fig. 1.7. A deca-saccharide can be attached to glycoproteins in *A. baumannii* ATCC 17978. Tandem MS of glycoproteins enriched by ZIC-HILIC showing the presence of a deca-saccharide composed of two capsular subunits linked to the AKPASTPAVK peptide of A1S\_0556.

### ***ΔpglC* mutants are attenuated in a murine septicaemia model**

To corroborate our *in vitro* serum challenge model, we also used *ΔpglC* in a murine septicaemia model. Acapsular mutants are strongly attenuated for virulence and quickly cleared from the rat soft tissue infection model (Umland et al. 2012). We used a previously described murine septicaemia model for *A. baumannii* (J A Iwashkiw et al. 2012), with wildtype *A. baumannii* ATCC 17978 having an LD<sub>50</sub> of  $6.49 \times 10^4$  CFU/challenge at 18 hours post infection. When *ΔpglC* was used at challenges approximately 1.5× and 5× the LD<sub>50</sub> ( $1.00 \times 10^5$  CFU/challenge and  $3.00 \times 10^5$  CFU/challenge) all mice

survived (n=5), while  $\Delta pglL$  killed 40% and 80% respectively (n=5). Survival of all mice challenged with  $\Delta pglC$  confirms that it is an essential protein for *A. baumannii* virulence, and therefore an interesting target for developing novel antibiotics.

### **Biofilm formation in $\Delta pglC$ is altered**

When grown in glass test tubes overnight, *A. baumannii* wildtype produces a thin ring of biomass at the water-air interface (Choi et al. 2009), but with  $\Delta pglC$  we observed aggregation of bacteria at the surface, and the water-air interface, producing towers of biomass on the walls of the test tube and a pellicle on the surface (Fig. 1.S5). The unusual behaviour of  $\Delta pglC$  led us to investigate the biofilms produced by this mutant using the same flow cell system established for  $\Delta pglL$  (J A Iwashkiw et al. 2012). After 24 hours of growth in a flow cell system significant differences between the Wt and  $\Delta pglC$  biofilms were apparent when stained with SYTO 9 and visualised by confocal microscopy (Fig. 1.8). A uniform film is produced by the wildtype (Fig. 1.8A), consistent with previous observations (J A Iwashkiw et al. 2012), while the  $\Delta pglC$  biofilm is very uneven, forming large dense clumps indicated by the signal intensity at various heights (z-sections) (Fig. 1.8B). When comparing total biomass and average height, both are not significantly different from one another, however, the maximum height of  $\Delta pglC$  is higher than Wt. This is repeated by the higher roughness coefficient in  $\Delta pglC$ , a measure of heterogeneity in the biofilm. Interestingly,  $\Delta pglL$  does not form any biofilms in this model (J A Iwashkiw et al. 2012), indicating a role for capsule as well as protein glycosylation.

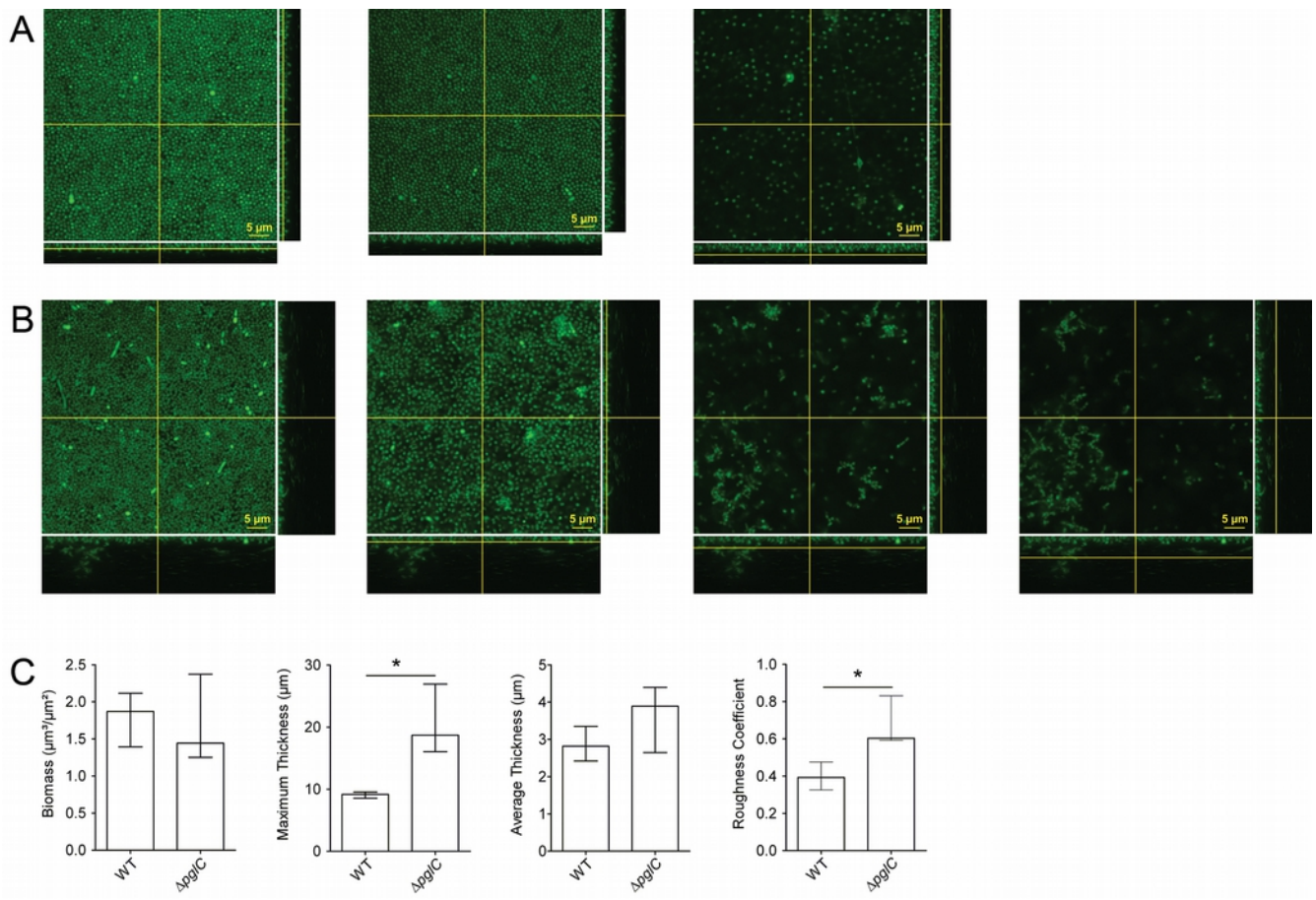

Fig. 1.8. Biofilms of *A. baumannii*  $\Delta pgIC$  exhibit distinct morphological differences compared to wildtype biofilms. Shown are representative confocal laser scanning microscopy images of the WT (A) and  $\Delta pgIC$  mutant (B) biofilms grown in flow cells for 24 h. The three or four images represent horizontal (xy, large panel) and vertical (xz and yz, side panels) projections at different z-levels (from left to right 0.13  $\mu\text{m}$ , 1.95  $\mu\text{m}$ , 5.2  $\mu\text{m}$  and 10.4  $\mu\text{m}$ ). (C) Image stacks of the WT and  $\Delta pgIC$  biofilms grown in flow cells for 24h were analyzed for the biomass, the maximum and average thickness as well as the roughness using the COMSTAT software. Shown are the medians of at least six image stacks from three independent experiments for each strain. The error bars indicate the interquartile range. Asterisks indicate significant differences (\*,  $P < 0.05$  [Mann-Whitney U test;  $n = 6$ ]).

## ***Discussion***

To further our understanding of the previously described *O*-linked protein glycosylation system found in *A. baumannii* ATCC 17978 (J A Iwashkiw et al. 2012), we interrogated the genome for carbohydrate utilisation genes that could contribute to producing its pentasaccharide. Of particular interest was the triple acetylated glucuronic acid terminal sugar (GlcNAc3NAcA4OAc), and this was used to identify homologues to the Wbp genes of *P. aeruginosa* that produce a similar, acetylated uronic sugar (Larkin and Imperiali 2009). In addition to these, we were able to identify all the component genes for a *wzy*-dependent CPS synthesis pathway, and sufficient glycosyltransferases for producing the identified pentasaccharide. Of these genes, A1S\_0061 was demonstrated to be an active initiator glycosyltransferase with homology to the *C. jejuni* PglC (CJJ81176\_1141) and we named it accordingly as PglC<sub>Ab</sub>. Initiator glycosyltransferases perform the specialised and essential function of transferring nucleotide activated sugars to the polyisoprenyl lipid carrier in the membrane (Glover et al. 2006). Generally divided by their substrate specificity and structural homology (Price and Momany 2005), they are present throughout surface carbohydrate synthesis pathways in diverse bacteria (Hug and Feldman 2011). Classifying A1S\_0061 more accurately will require investigating its substrate specificity. We hypothesise that it transfers GalNAc, as this is the reducing end sugar identified by NMR, but this could be incorrect as demonstrated by *E. coli* O157 that uses an undecaprenylpyrophosphate-GlcNAc to GalNAc-UndPP epimerase (Rush et al. 2010). It is also unclear from our activity assay, as the heptasaccharide has been shown to be antibody reactive and fully formed despite variability in the reducing end sugar (Wacker et al. 2002).

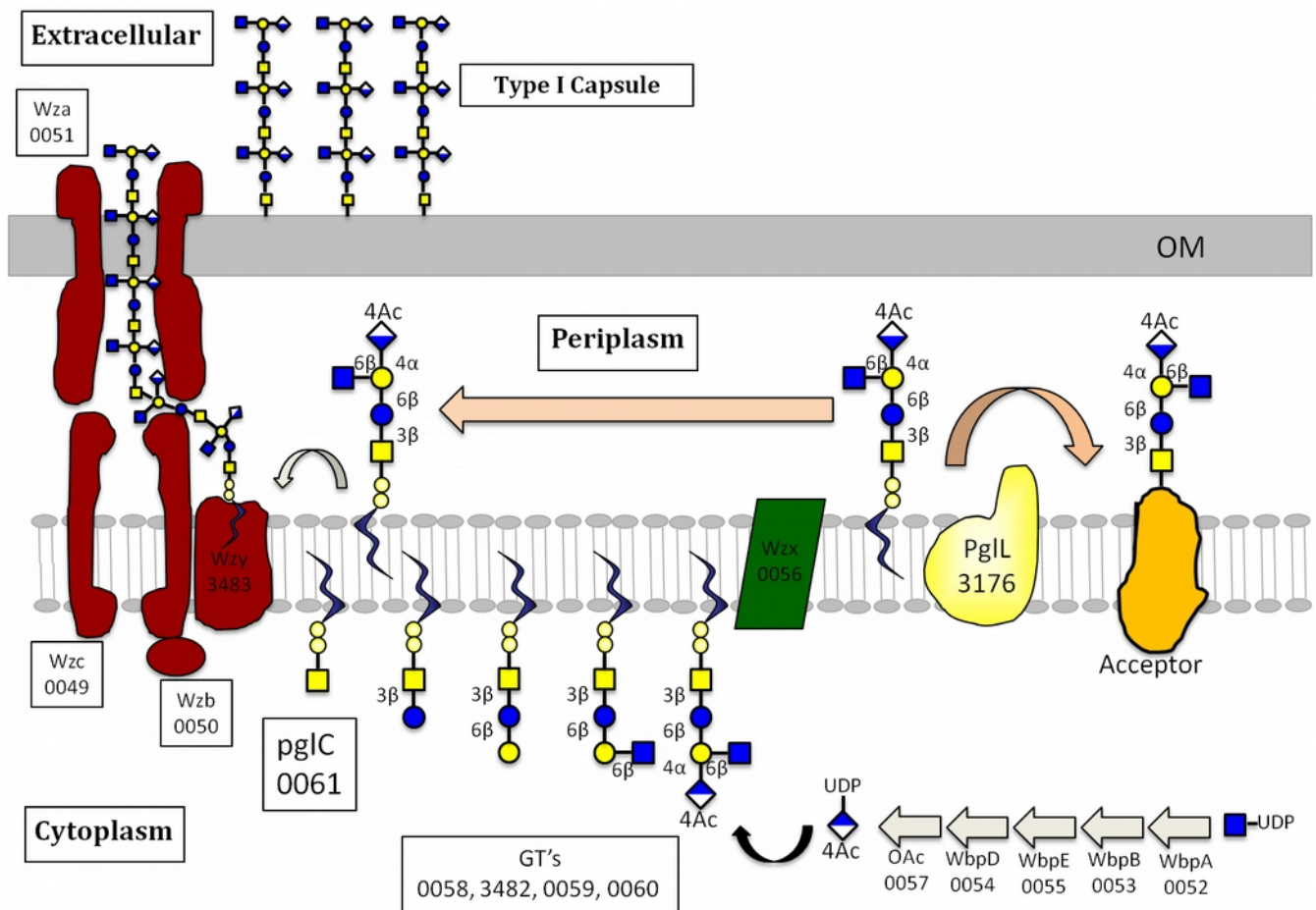

Fig. 1.9. Proposed model for the bifurcated pathway for protein glycosylation and capsule biosynthesis in *A. baumannii* ATCC 17978 showing relevant enzymes for cytoplasmic synthesis and periplasmic assembly.

Our work clearly demonstrates that CPS and O-linked protein glycosylation are linked in *A. baumannii* through the synthesis of a common pentasaccharide that is attached to proteins or polymerised to form CPS. To explain this, we propose a bifurcated model (Fig. 1.9), where synthesis in the cytoplasm begins with the addition of GalNAc-1-P to UndP by the activity of PglC (A1S\_0061) and is then further elaborated by four glycosyltransferases (A1S\_0058, A1S\_3482, A1S\_0059, and A1S\_0060) to form the full pentasaccharide. The unique terminal sugar is synthesised by five additional genes (A1S\_0052-A1S\_0057). The completed pentasaccharide is flipped into the periplasm by the flippase (A1S\_0056), and then the pentasaccharide is conjugated to proteins by the PglL O-Tase



(A1S\_3176), or polymerised by Wzy (A1S\_3483) and exported through the Wza (A1S\_0051) channel as CPS.

A bifurcated model using the same glycan poses challenges for the bacteria in terms of regulating the length of oligosaccharides added to glycoproteins. Two general systems have been identified by which bacteria accomplish this: OTase specificity and polymer sequestration. *P. aeruginosa* utilises the same glycan for its pilin O-glycans and LPS O-antigen (Castric, Cassels, and Carlson 2001), restricting glycan length with the PilO OTase active site only accommodating short oligosaccharides (Faridmoayer et al. 2007). *E. coli* O9:K30 uses different oligosaccharides for its LPS O-antigen and K-capsular antigen, but they can both be transferred to lipid A by the O-antigen ligase, WaaL. Normally only single K30 subunits are found on LPS, but in a mutant of the capsule export machinery long polymers can be found attached to LPS (Drummel-Smith and Whitfield 1999). The products of the O-antigen polymerisation are freely available in the periplasm for WaaL, but K30 polymers are normally sequestered immediately into the export machinery, preventing their addition to LPS. It is unclear which of these systems *A. baumannii* uses, and it is an interesting direction of future research to knockout the Wza export channel and examine the effect on glycoproteins, as well as test the ability of PglL, the *A. baumannii* OTase, to transfer polymeric glycans.

Carbohydrate use in bacteria is highly modular. A small number of functions are performed with a great variety of combinations to provide a wide array of possible outcomes. The surface structure of bacteria is highly dependent on carbohydrates, with peptidoglycan, LPS, glycoproteins, and CPS all depending on very similar sets of enzymes for their initiation (Price and Momany 2005), elaboration (Bernatchez et al. 2005; Karlyshev et al. 2005), and in some cases their terminal steps (Hug and Feldman 2011; Power, Seib, and Jennings 2006). The combining of these various modular elements can serve many roles. In some cases this is the highly specific practise of biomimicry and immune evasion are under strong selective pressure, in which case bacteria have developed a wide array of means to

fool host immune systems (Lewis et al. 2009; Morrison and Imperiali 2014). For others, being highly adaptable and capable of modifying sugar structures to fit different niches would be more advantageous. Given the modular setup of the *A. baumannii* glycan synthesis cluster and the observed diversity in its components (Kenyon and Hall 2013; Scott et al. 2014), it likely falls into the latter, using sugars to adapt to and persist in a wide variety of environments from soil to patients. Studying and understanding its glycome will therefore be necessary to developing strategies to combat it going into the future.

## ***Materials and Methods***

Materials and methods reproduced from “A Common Pathway for O-Linked Protein-Glycosylation and Capsule in *Acinetobacter baumannii*” Robert G. Lees-Miller, Jeremy A. Iwashkiw, Nichollas E. Scott, Andrea Seper, Evgeny Vinogradov, Stefan Schild, and Mario F. Feldman. *Molecular Microbiology* 12 July 2013 Issue **89**(5), pages 816-830.

### *Bacterial Strains and Growth Conditions*

All strains were grown in Luria-Bertani (LB) media at 37°C with shaking at 200 rpm unless otherwise stated. All strains used in this study are included in Table 2. Antibiotics were used as necessary for selection at the following concentrations: ampicillin 100 µg mL<sup>-1</sup>, tetracycline 5 µg mL<sup>-1</sup>, chloramphenicol 10 µg mL<sup>-1</sup>, spectinomycin 80 µg mL<sup>-1</sup>, and kanamycin 50 µg mL<sup>-1</sup>. Inducers used for protein expression were isopropyl- β-D-thiogalactopyranoside (IPTG) at 20 µg/mL and L-arabinose at 0.2%.

### *DNA Manipulation Procedures*

Plasmid and DNA extractions were performed using the QIAGEN Spin Miniprep, DNEasy Blood and Tissue, and QIAquick PCR Purification kits. PCR fragments were amplified using Vent Thermopol polymerase (New England BioLabs). All restriction enzymes were from New England BioLabs. Primers used in this study are included in Table 2.

### *Construction of an unmarked *A. baumannii* Δ*pglC* knockout and in trans complementation*

Knockout was performed using a modified protocol of Aranda et al. (2005). Two 800 bp fragments, one directly upstream and downstream of A1S\_0061 were amplified from genomic DNA using *pglCUpFwd/Rev* and *pglCDwnFwd/Rev*. Fragments included homologous regions that overlap with each other on the 3' end of the upstream and 5' end of the downstream region. Both 800 bp fragments were combined in equimolar concentrations in a PCR reaction with *pglCNestFwd* and *pglCNestRev* primers containing BamH1 and EcoR1 cut sites. The approximately 1500 bp recombined fragment was cloned into pEXT20. The recombined fragment was subcloned into pAbKO, an unmarked deletion suicide vector consisting of a modified pFLP2 marked deletion suicide vector

containing a kanamycin resistance cassette in the backbone at the NheI site. The pAbKO suicide vector was transformed into electrocompetent *A. baumannii* ATCC 17978 and single crossover insertions of the plasmid were selected by growing on kanamycin and verified by PCR. Individual colonies were then passaged for three days without selection pressure. Double crossovers were selected using 10% sucrose agar plates to exploit the *sacB* lethal gene contained in pAbKO. Mutants were verified using colony PCR followed by genomic extracts with primers *pglCOutFwd* and *pglCOutRev* to confirm the 700 bp deletion of A1S\_0061. Complementation *in trans* was accomplished using the pWH1266 *E. coli/A. baumannii* shuttle vector with a hexa-His tagged *pglC* cloned using *kpglCFwd* and *kpglCRev* into the EcoRI and PstI cut sites under constitutive expression by the Tet promoter.

#### *SDS-PAGE and Periodic Acid-Schiff (PAS) Stain of Membrane Extracts*

Bacterial cultures were pelleted by centrifugation for 15 min at 10,000×g, washed with PBS, resuspended in PBS, and lysed by French Press. Unbroken cells were pelleted by centrifugation for 15 minutes at 14,000×g. The supernatant was ultracentrifugated for 1 h at 100,000×g (4°C) to pellet total membrane. Samples were quantified by Bradford protein quantification (Biorad) and analyzed on a 12% SDS-PAGE. The PAS stain protocol used was previously described (Cagatay & Hickford, 2008). In brief, 0.7% periodic acid in 5% acetic acid is used to oxidise cis-diol sugars and sensitize them for staining with Schiff reagent (Sigma).

#### *Microscopy*

Glass coverslips were immersed in 5 mL of LB and inoculated then incubated for 2 h at room temperature. Slips were washed three times in PBS then immersed in 3.7% paraformaldehyde in PHEM buffer for 15 minutes to fix. Slips were washed three times in PBS then immersed in filtered 0.25% Alcian Blue 8GX (Sigma) in 25% ethanol and 10% acetic acid for 2h. Slips were washed three times in PBS then flooded with 0.25% O-safranin in 25% ethanol for 1 minute and washed three times in PBS. Slips were inverted, mounted using Glycerol-PPD (90% glycerol, 0.5% p-phenylenediamine in Tris) and examined at 1000x magnification.

#### *Flow cell biofilm, fluorescent staining, and confocal laser scanning microscopy*

Flow cell experiments and fluorescent staining were performed as described previously by (Seper *et al.*, 2011). Briefly, the respective overnight cultures were adjusted to OD<sub>600</sub> = 0.1 using 50-

fold diluted LB (2%). Per channel, approximately 250  $\mu$ l of the dilutions were inoculated. After static incubation for 2 h, flow of pre-warmed 2% LB (37°C) was initiated (3 ml/h). Biofilms were allowed to form for a time period of 24 h and were stained with SYTO 9 (Invitrogen) for visualization. Images of biofilms were acquired using a Leica SP5 confocal microscope (Leica Microsystems, Mannheim, Germany) with spectral detection and a Leica HCX PL APO CS 63x water objective (NA 1.2). For the SYTO 9 signal, the excitation wavelength was set at 488 nm and fluorescence emission was detected between 500-530 nm. Optical sections were recorded in 0.13  $\mu$ m steps. For two-dimensional image visualization the Fiji ImageJ software was used (Schindelin *et al.*, 2012). Quantification of image stacks was performed using COMSTAT (Heydorn *et al.*, 2000). For COMSTAT analysis at least six image stacks from three independent experiments were used.

#### *Complement Killing Assay for A. baumannii*

Relevant strains of *A. baumannii* were reinoculated from overnight cultures into fresh LB, and incubated for 4 h at 37°C. Aliquots equivalent to 0.15  $OD_{600}$  of bacteria were centrifuged at 5,000 $\times$ g for 10 min, washed in PBS, centrifuged again and resuspended in 150  $\mu$ L of 100% pooled complement human serum (Innovative Research) or horse serum (Gibco). Serial ten-fold dilutions in 150  $\mu$ L of serum were performed in a 96-well plate and aliquots of 10  $\mu$ L were plated on LB agar immediately after inoculation. The 96-well plate was sealed with parafilm and incubated for 3 h at 37°C and then another 10  $\mu$ L aliquot was plated on LB agar from each well. Aliquot plates were incubated overnight at 37°C and assessed for growth. Heat-inactivated serum was made by heating serum at 56°C for 10 minutes.

#### *Virulence in BALBC/3 Septicaemia Mouse Model*

A murine model of disseminated sepsis using BALB/c mice (16-20 grams) was used for bacterial challenge (Ko *et al.*, 2004, Fattahian *et al.*, 2011). *A. baumannii* strains were grown for 18 h at 37 °C in Luria broth with appropriate antibiotics and adjusted to the appropriate concentration in physiologic saline. Inoculums were prepared by mixing the bacterial suspensions 1:1 (v:v) with a 10% solution (w/v) of porcine mucin (Sigma, St. Louis, MO) which increases the infectivity of *A. baumannii*, allowing for a lower concentration of bacteria to be used (McConnell & Pachon, 2010, McConnell *et al.*, 2011, Batson *et al.*, 1950). Mice were injected intraperitoneally with 0.2 ml of the bacterial / mucin inoculums. Bacterial concentrations were determined by plating dilutions on Luria

agar.

Determining the wild type strain lethal dose for 50% of animals was determined by the limit test where groups of 5 mice were infected with dilutions of bacteria, at a range of concentrations within 2 logs of a concentration of bacteria that had previously been shown to be lethal with this species of bacteria using a disseminated sepsis model. Comparison of complemented and mutant bacteria was carried out using the sepsis model of infection as described where concentrations of bacteria used were equal to several LD 50s of WT.

Spleen, liver and lung bacterial loads were determined in mice administered  $1 \times 10^5$  CFU of *A. baumannii*. Surviving mice were euthanized 18 h post-infection lungs, livers and spleens were aseptically removed and homogenized via passage through a cell strainer (BD falcon 70  $\mu$ m cell strainer) in saline before plating serial log dilutions on Luria agar plates for bacterial quantification.

#### *Purification of Capsular Polysaccharide*

*A. baumannii* was reinoculated from overnight culture into 8L of LB and grown overnight. Cells were harvested by centrifugation at 10 000 x g for 10 minutes and washed three times with PBS then resuspended in 150 mL of mQH20 and lysed using a French Press. Unlysed cells and debris was removed by centrifugation at 10 000 x g for 20 minutes. Membranes were then removed by centrifugation at 100 000 x g for 1 h. The supernatant was then treated with 1  $\mu$ g/mL of DNase and RNase E (Sigma) for 3h at 37°C followed by incubation with 50  $\mu$ g/mL of Proteinase K (Sigma) overnight at 60°C followed by 50  $\mu$ g/mL Pronase E (Sigma) digestion overnight at 37°C before lyophilisation. Lyophilate was resuspended in 12 mL of mQH2O. Insoluble precipitate was removed by sequential centrifugation at 16000 x g. The soluble fraction was assayed for sugar content using the Phenol-Sulfuric sugar determination (Dubois M, 1956) and protein content using Bradford (Biorad), as well as verification by running on 15% SDS-PAGE and PAS staining. Volume was increased to 20mL and clarified by ultracentrifugation at 100 000 x g for 1 h. Supernatant was dialyzed, filtered through 0.45  $\mu$ m membrane and desalted on a Sephadex G-50 column. Product was hydrolyzed with 2% acetic acid for 30 min at 100°C, precipitate removed by centrifuge, and the product dried and used for NMR.

#### *NMR spectroscopy analysis*

NMR experiments were carried out on a Varian INOVA 500 MHz (1H) spectrometer with 3 mm gradient probe at 30 °C with acetone internal reference (2.225 ppm for 1H and 31.45 ppm for 13C)

using standard pulse sequences gCOSY, TOCSY (mixing time 120 ms), NOESY (mixing time 300 ms), gHSQC and HMBC (100 ms long range transfer delay). AQ time was kept at 0.8-1 sec for H-H correlations and 0.25 sec for HSQC, 256 increments was acquired for t1.

Assignment of spectra was performed using Topspin 2 (Bruker Biospin) program for spectra visualization and overlap. Monosaccharides were identified by COSY, TOCSY and NOESY cross peak patterns and <sup>13</sup>C NMR chemical shifts. Aminogroup location was concluded from high field signal position of aminated carbons (CH at 45-60 ppm). Connections between monosaccharides were determined from transglycosidic NOE and HMBC correlations.

#### *Protease digestion and enrichment of glycopeptides by zwitterionic hydrophilic interaction chromatography (ZIC-HILIC)*

Dried membrane fractions enriched for proteins were resuspended in 6 M urea, 2 M thiourea, 40 mM NH<sub>4</sub>HCO<sub>3</sub>. Samples were reduced, alkylated, digested with Lys-C (1/200 w/w) and then trypsin (1/50 w/w) as described previously (Scott *et al.*, 2011). Digested samples were dialyzed against ultra-pure water overnight using a Mini Dialysis Kit with a molecular mass cut off of 1000 Da (Amersham Biosciences, Buckinghamshire, UK) and were collected and lyophilized on completion. ZIC-HILIC enrichment was performed with minor improvements from Scott *et al.*, 2011. Micro-columns composed of 10 µm ZIC-HILIC resin (Sequant, Umeå, Sweden) were packed into P10 tips on a stage of Empire C8 material (Sigma) to a bed length of 0.5 cm and washed with ultra-pure water prior to use. Dried digested samples were resuspended in 80% acetonitrile (ACN) and 5% formic acid (FA) then centrifugation at 20,000×g for 5 min at 4°C was used to remove insoluble material. Samples were adjusted to 2 µg/µL and 100 µg of peptide material loaded onto a column and washed with 10 load volumes of 80% ACN, 5% FA. Peptides were eluted with 3 load volumes of ultra-pure water into low-bind tubes and concentrated by vacuum centrifugation.

#### *Identification of glycopeptides using reversed phase LC-MS-MS*

ZIC-HILIC fractions were resuspended in 0.1% FA and loaded onto a Acclaim PepMap 100 µm C18 Nano-Trap Column (Dionex Corporation, Sunnyvale, CA) for 10min using an UltiMate 3000 intelligent LC system (Dionex Corporation). Peptides were eluted and separated on 20 cm, 100 µm inner diameter, 360 µm outer diameter, ReproSil – Pur C18 AQ 3 µm (Dr. Maisch, Ammerbuch-Entringen, Germany) in-house packed column. Enriched peptides derived from tryptic digests were

analysed using an LTQ-Orbitrap Velos (Thermo Scientific, San Jose CA). Samples were eluted using a gradient from 100% buffer A (0.5% acetic acid) to 40% buffer B (0.5% acetic acid, 80% MeCN) over 120min at a constant flow of 200 nL/min enabling the infusion of sample in the instrument using ESI. The LTQ-Orbitrap Velos was operated using Xcalibur v2.2 (Thermo Scientific) with a capillary temperature of 200°C in a data-dependent mode automatically switching between MS ion trap CID and HCD MS-MS. For each MS scan, the three most abundant precursor ions were selected for fragmentation with CID, activation time 30ms and normalized collision energy 35, followed by HCD, activation time 30ms and normalized collision energy 45. MS resolution was set to 60,000 with an ACG of  $1e^6$ , maximum fill time of 500ms and a mass window of m/z 600 to 2000. MS-MS fragmentation was carried out with an ACG of  $3e^4/2e^5$  for CID/HCD and maximum fill time of 100 ms/500 ms CID/HCD. For HCD events an MS resolution of 7500 was set. A total of three HILIC enrichments were performed and analysed by the above protocol.

#### *Database interrogation of identified glycopeptides*

Raw files were processed within Proteome Discover version 1.0 Build 43(Thermo Scientific) to generate .mgf files. To identify possible glycopeptides within exported scans, the MS-MS module of GPMAW 8.2 called 'mgf graph' was utilized. This module allowed the identification of all scan events within the generated .mgf files containing the diagnostic oxonium m/z 301.10 ion. These scan events were manually inspected and identified as possible glycopeptides based on the presence of the deglycosylated peptide ion with a tolerance of 20 ppm. To facilitate glycopeptide assignments from HCD scan events, ions below the mass of the predicted deglycosylated peptides were extracted with Xcalibur v2.2 using the Spectrum list function. Ions with a deconvoluted mass above the deglycosylated peptide mass and ions corresponding to known carbohydrate oxonium ions such as 204.08 and 366.14 were removed in a similar approach to post-spectral processing of ETD data (Good *et al.*, 2009, Good *et al.*, 2010). MASCOT v2.2 searches were conducted via the Australasian Proteomics Computational Facility ([www.apcf.edu.au](http://www.apcf.edu.au)) with the Proteobacteria taxonomy selected. Searches were carried out with a parent ion mass accuracy of 20 ppm and a product ion accuracy of 0.02 Da with no protease specificity, instrument selected as MALDI-QIT-TOF (use of this instrumentation setting was due to the observation of multiple internal cleavage products, extensive  $NH_3$  and  $H_2O$  loss from a, b, y ions, which are all included within this scoring setting) as well as the fixed modification carbamidomethyl (C) and variable modifications, oxidation (M) and deamidation



(N). An ion score cut-off of 20 was accepted and all data were searched with the decoy setting activated generating a zero false positive rate generated against the decoy database.

Supplemental Figures

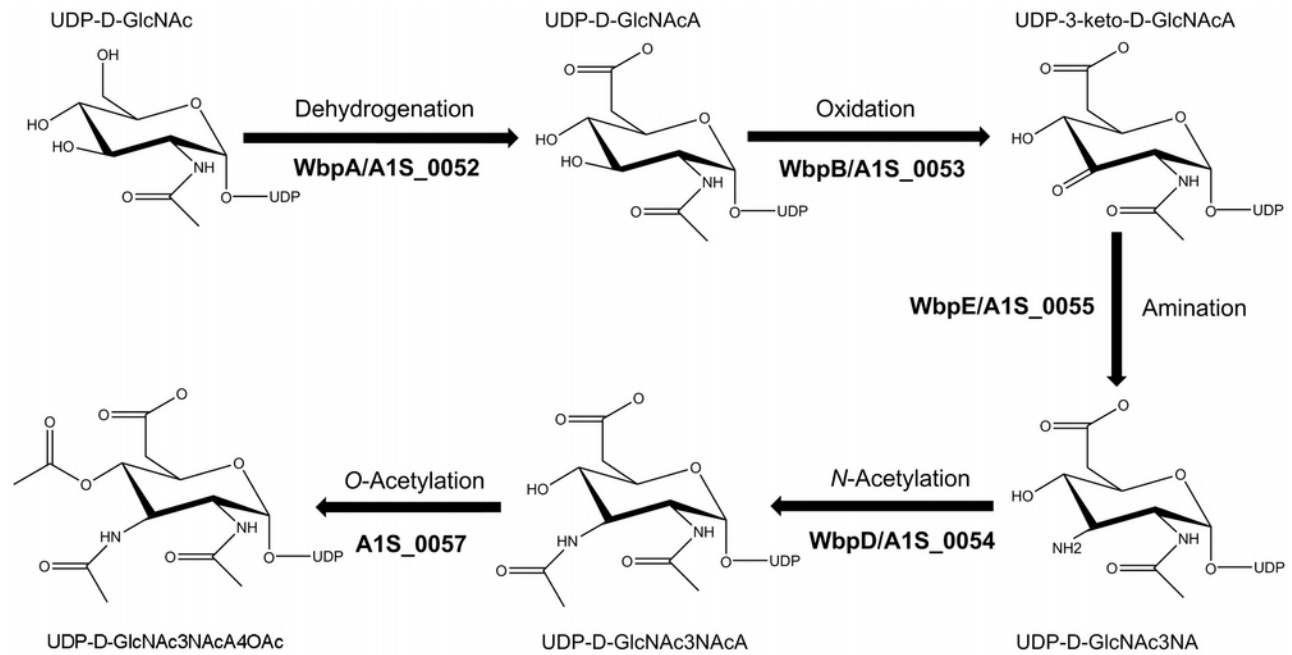

Fig. 1.S1. Proposed pathway for the synthesis of GlcNAc3NAcA4OAc in *A. baumannii* ATCC 17978. Homologue and putative gene ID for each step is indicated with the reaction step.

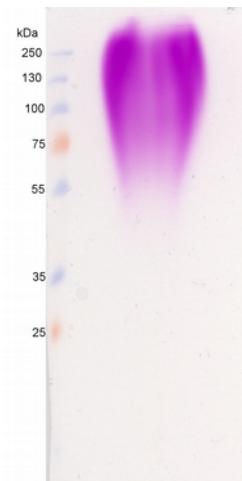

Fig. 1.S2. PAS stain of extracted capsule is consistent with observations of capsule size using membrane extracts. Purified capsule was visualised on a 10% SDS-PAGE followed by PAS staining.

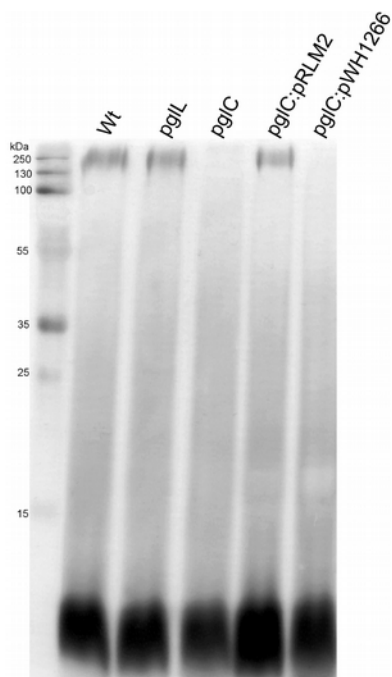

Fig. 1.S3. Mutation of A1S\_0061 does not affect LOS of *A. baumannii* ATCC 17978. LOS was isolated by Proteinase K digestion of whole cell samples in urea buffer for 18 h at 60°C then Pronase E digestion for 18 h at 37°C and visualised on a 15% SDS-PAGE followed by silver staining. Wildtype *A. baumannii* ATCC 17978 (Wt),  $\Delta pglL$  (pglL),  $\Delta pglC$  (pglC), complemented with constitutive PglC expression (pglC:pRLM2), and empty vector (pglC:pWH1266). No observable changes in the LOS occur. Lack of laddering pattern indicates that LPS is not present.

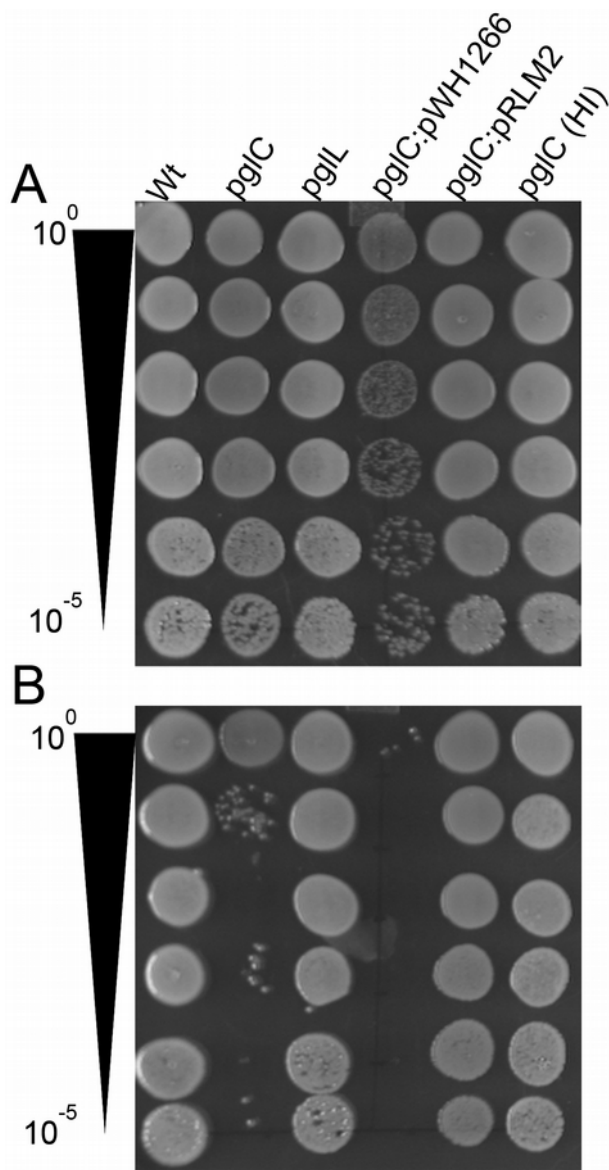

Fig. 1.S4. Survival of *A. baumannii* strains in 100% horse serum is similar to survival in 100% human complement serum. (A) Initial inoculums of  $1 \text{ OD}_{600\text{mL}^{-1}}$ : Wt (lane 1),  $\Delta pglL$  (lane 2),  $\Delta pglC$  (lane 3),  $\Delta pglC:pWH1266$  vector control (lane 4),  $\Delta pglC:pRLM2$  PglC complementation (lane 5) in 100% serum; and  $\Delta pglC$  in heat-inactivated serum (lane 6) were serially diluted from  $1 \text{ OD}_{600\text{mL}^{-1}}$  (Row 1) to  $1 \times 10^{-5} \text{ OD}_{600\text{mL}^{-1}}$  (Row 6) in serum.  $10 \mu\text{L}$  were spotted in duplicate on LB agar to estimate bacterial concentration. (B) Survival after incubation for 3 h at  $37^\circ\text{C}$ . Heat-inactivated (HI) serum has been heated at  $65^\circ\text{C}$  for 15 minutes to inactivate protein factors.

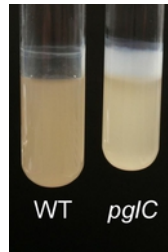

Fig. 1.S5. Growth of *A. baumannii* ATCC 17978 wildtype and  $\Delta pglC$  in glass test tubes overnight indicates different biofilm formation behavior.

# Manuscript 2: Characterising the Substrate Specificity of the *Acinetobacter baumannii* PglC Initiator Glycosyltransferase

Robert Lees-Miller<sup>1</sup>, Mario Feldman<sup>1\*</sup>

<sup>1</sup> Alberta Glycomics Centre, Department of Biological Sciences, University of Alberta, CW405 Biological Sciences Building, Edmonton, Alberta, Canada T6G 2E9.

**Abstract:** Initiator glycosyltransferases are a family of enzymes critical to numerous surface carbohydrate pathways. They transfer nucleotide activated sugars to lipid carriers in the membrane, allowing for the construction of oligosaccharides which can be exported to the periplasm and used for peptidoglycan synthesis, lipopolysaccharide, capsular polysaccharide, various exopolysaccharides, and protein glycosylation. Normally they are considered to be highly specific, but initial observations of the *A. baumannii* PglC indicate this could be untrue for some enzymes. To investigate this observation, we developed 3 *in vivo* models for testing substrate specificity by complementation of mutants in different iGTs and demonstrated that PglC can transfer multiple sugars. We then applied site-directed mutagenesis to restrict and switch substrate specificity, generating several point mutants with modified activity. To further quantify these observations, we made progress toward developing an assay amenable to high-throughput screening of PglC activity through the derivatisation of UMP to produce luminescence in a one-pot assay. This work provides interesting observations of highly unusual behaviour in an important enzyme, and lays the ground work for developing strategies to target this enzyme which has previously been identified as absolutely essential for the virulence of *A. baumannii*.

## ***Introduction***

*Acinetobacter baumannii* O-linked protein glycosylation was first demonstrated in 2012 (J A Iwashkiw et al. 2012), with the cluster responsible for its synthesis identified through mutation analysis (Lees-Miller et al. 2013), as well as identified bioinformatically (Kenyon and Hall 2013) to be conserved throughout the *Acinetobacter* genus. While the cluster's general architecture was well conserved, there was considerable diversity in end product oligosaccharides identified on glycoproteins (Scott et al. 2014), notably the reducing end sugars were both HexNAc and bacillosamine despite the initiator glycosyltransferase being highly conserved. This was unusual, as typically iGTs display very strong substrate specificity (Price and Momany 2005; Valvano 2011), though there are notable difficulties in using a bioinformatics dependent approach to identify substrate specificity.

Typically, iGTs are classified based on their homology into two broad categories: 11 transmembrane domain **P**olyisoprenylphosphate *N*-acetylaminosugar-1-**P** Transferases (PNPTs), and 5 transmembrane domain PHPTs transferring **H**exose-1-P (Valvano 2011). The first to be discovered were the *MraY*, polyisoprenol phosphate *N*-acetylmuramic acid-1-P transferase (Meadow, Anderson, and Strominger 1964; Hammes and Neuhaus 1974), iGTs responsible for the addition of MurNAc-pentapeptide to undecaprenylphosphate in the bacterial peptidoglycan synthesis pathway (van Heijenoort 2001). Typically, *MraY* has 11 transmembrane domains, though some have additional domains (Bouhss et al. 1999; Price and Momany 2005) and are  $Mg^{2+}$  dependent (Heydanek, Struve, and Neuhaus 1969). The specificity of *MraY* can vary for pentapeptide substitutions (Price and Momany 2005), or through a single isoleucine to phenylalanine substitution in Mycobacteria (MAP**I**H<sub>4</sub>H<sub>4</sub>H<sub>4</sub>FEL to MAP**F**H<sub>4</sub>H<sub>4</sub>H<sub>4</sub>FEL) causing a switch from requiring *N*-acetylated muramic acid to *N*-glycolated muramic acid (Raymond et al. 2005), as well as being highly permissive for different lengths of isoprenoids other than undecaprenol, though *MraY* iGTs are highly specific for the sugar muramic acid (Brandish et

al. 1996).

WecA has a similar 11 transmembrane domain architecture and shares many of the same functional domains as MraY, though with an additional domain (Anderson, Eveland, and Price 2000). It is important to LPS O-antigen and Enterobacterial Common Antigen synthesis (Schmidt, Mayer, and Mäkelä 1976). WecA was demonstrated to have high specificity for *N*-acetylglucosamine (GlcNAc) (Barr, Nunes-Edwards, and Rick 1989), and a Mg<sup>2+</sup> requirement through a DxDD motif (Amer and Valvano 2002), which is also present in other isoprenoid transfer enzymes (Joly and Edwards 1993), and common in all of the 11 transmembrane iGTs (Price and Momany 2005). There is also a HIIH domain that caused reduced tunicamycin binding indicative of playing a role in substrate specificity (Amer and Valvano 2001; Amer and Valvano 2002). Two additional motifs are highly conserved but their function is unclear, NxxNxxDGIDGL (Dal Nogare, Dan, and Lehrman 1998), and VMFGD (Furlong and Valvano 2012). An unusual case made structural homology ambiguous for classification of substrate specificity: *E. coli* O157, where the LPS O-antigen structure determined by NMR showed the reducing sugar to be GalNAc, with only WecA present in the genome. The difference was resolved by the discovery of an epimerase that catalysed a GlcNAc to GalNAc epimerisation of the undecaprenylphosphate linked GlcNAc (Rush et al. 2010).

The possibility of broader specificity in PNPTs is also demonstrated by WbcO from *Yersinia enterocolitica* (Skurnik et al. 1999) and WbpL of *Pseudomonas aeruginosa* (Rocchetta et al. 1998) which are present in strains with GlcNAc, QuiNAc, and FucNAc reducing sugars in their LPS. Both share common motifs with WecA and MraY with some unique sites (Anderson, Eveland, and Price 2000). It has not been determined, however, whether the diversity of sugars found in these bacteria is due to changes in the enzyme or the presence of epimerases similar to *E. coli* O157, as



epimerase mutations cause identical phenotypes to WbpL knockouts (Burrows, Charter, and Lam 1996), as well as complementation of WecA deletions by WbpL from strains with QuiNAc reducing sugars (Rocchetta et al. 1998).

The second class of enzymes, PHPTs, are typically related to WbaP, the galactose-1-P transferase from *Salmonella sp.* Notably, unlike the PNPTs, which are highly homologous to the eukaryotic iGTs thus causing tunicamycin's eukaryotic toxicity (Valvano 2003), the PHPTs are found only in bacteria (Price and Momany 2005). Consisting of 5 transmembrane domains, it was demonstrated that only the final TM helix and cytoplasmic domain are necessary for *in vitro* function (Wang, Liu, and Reeves 1996), and sufficient for *in vivo* function (Patel, Furlong, and Valvano 2010). The first 4 TM segments are also poorly conserved outside of the *Salmonella* genus and the cytoplasmic segment is much more conserved in other bacteria (Saldías et al. 2008). The single TM PHPT WchA is also present in *Caulobacter crescentus* holdfast synthesis (Toh, Kurtz, and Brun 2008), and *Streptococcus pneumoniae* capsule synthesis and shown to transfer glucose-1-P (Pelosi et al. 2005). Some marginal complementation of WbaP galactose-1-P transfer by WchA was detected *in vivo* but could not be quantified *in vitro* (Patel et al. 2012).

The difficulty of assigning substrate specificity based on structural homology is further complicated by WecP and PglC. WecP from *Aeromonas hydrophila* was demonstrated to transfer *N*-acetylgalactosamine-1-P, despite strong structural homology to WbaP (Merino et al. 2011). The PglB iGT (not the PglB *N*-oligosaccharyltransferase of *C. jejuni*) from *Neisseria meningitidis* (Hartley et al. 2011) and PglC from *Campylobacter jejuni* (Glover et al. 2006) transfer di-*N*-acetylbacillosamine (diNAcBac), a trideoxy sugar unique to bacteria (Morrison and Imperiali 2014), further complicating the classification of single TM iGTs as PNPTs or PHPTs. While mutational analysis of the WbaP C-

terminal domain was conducted (Patel, Furlong, and Valvano 2010), no such studies have been conducted with the naturally truncated PHPTs, and they are not as well conserved (Hartley et al. 2011).

The PglC from *Acinetobacter baumannii* ATCC 17978 that we previously identified (Lees-Miller et al. 2013), is closest to the di-*N*-acetylglucosamine-1-P transferases, making their substrate classification more ambiguous. It would be highly unusual for a complex sugar to be reversed into a less complicated sugar after transfer, as might be the case in ambiguities resulting from epimerase activity. *A. baumannii* bacillosamine synthesis has also been characterised and occurs before undecaprenylphosphate transfer (Morrison and Imperiali 2013). In addition to the above mentioned diversity of reducing end sugars depending on highly conserved PglC enzymes in *Acinetobacter sp.* an additional question was raised but not explored in our previous publication. The *Campylobacter jejuni* heptasaccharide synthesis pathway reconstituted in *E. coli*, which was used to demonstrate that the PglC was a functional iGT (Lees-Miller et al. 2013), is not indicative of specificity, as it can be completed by the addition of at least *N*-acetylglucosamine, or the native di-*N*-acetylglucosamine (Wacker et al. 2002) to its reducing end. Notably, neither is the native reducing end sugar in *A. baumannii* ATCC 17978 (J A Iwashkiw et al. 2012), and UDP-GalNAc is not usually present in *E. coli*. The *pgl* operon of *C. jejuni* does, however, contain a UDP-GlcNAc to UDP-GalNAc epimerase that acts on the soluble, nucleotide activated sugars (Fry et al. 1998; Bernatchez et al. 2005; Cunneen et al. 2013), so this possibility cannot be excluded. To determine if the *A. baumannii* PglC does represent a novel, relaxed specificity iGT we developed a panel of *in vivo* assays for determining substrate specificity in initiator glycosyltransferases, used site-directed mutagenesis to identify catalytically relevant amino acids, and made progress toward *in vitro* methods amenable to high-throughput analysis of these difficult to study enzymes.

## **Results**

### **Building *in vivo* Models for Specificity**

Several systems were developed to help resolve the specificity of PglC through the use of antibodies. For *N*-acetylated sugars we used *E. coli* O16 LPS complementation for determining GlcNAc transfer, and a *Neisseria meningitidis* derived synthesis plasmid expressed in *E. coli* for bacillosamine. To test the possibility of hexose transfer, we used two strains: *E. coli* O9 and *Salmonella enterica* that utilise galactose.

To restore the *E. coli* O16 LPS in the CLM37 *wecA*- strain requires addition of the RhaT rhamnosyltransferase to complement an existing mutation in the *E. coli* K12 parent strain accomplished using the pMF19 plasmid (Feldman et al. 1999), and an initiator glycosyltransferase capable of transferring GlcNAc to complement the *wecA* mutation. LPS was isolated, separated by SDS-PAGE, and detected by silver staining and Western blot using an anti-O16 LPS antibody. PglC was able to complement O16 LPS synthesis at levels equal to heterologous expression of *WecA* (Fig. 2.1AB).

To test for bacillosamine transfer, we used the *N. meningitidis* derived pEF33 plasmid carrying genes for bacillosamine synthesis and transfer (Ielmini and Feldman 2011). Bacillosamine is detected after transfer to lipid A by the native WaaL O-antigen ligase through Western blotting using a bacillosamine specific antibody. For this assay, we developed a site-directed mutant in *pglB*, which is the *pglC* homologue. The mutant strain did not produce bacillosamine, and was successfully complemented with the heterologous expression of PglC (Fig. 2.1E).

To test for PglC ability's to complement PHPTs, we used an *S. enterica wbaP* deletion mutant (Saldías et al. 2008). Western blotting of LPS was again used to determine activity. Complementation

by expression of WbaP was successful, but PglC could not complement the *wbaP* deletion in *S. enterica* (Fig. 2.1C) indicating that it cannot transfer galactose. An additional verification was provided by the failure to complement an *E. coli* O9 *wbaP* deletion strain (Drummel-Smith and Whitfield 1999) (Fig 2.1D).

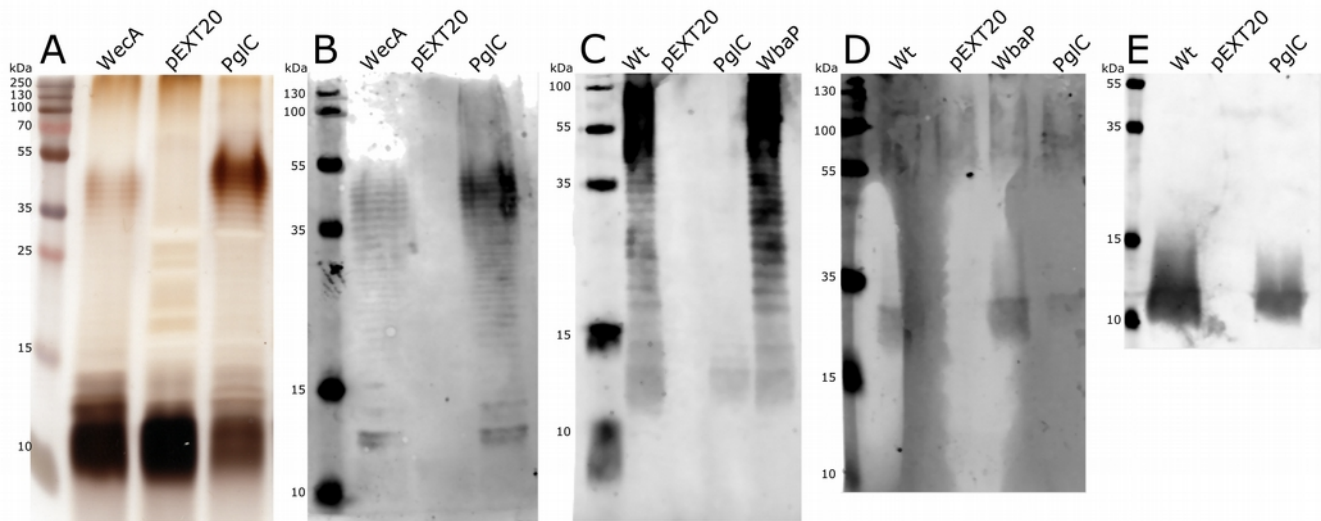

Figure 2.1. Complementation of *in vivo* models for iGT activity by *A. baumannii* PglC. LPS was purified by phenol extraction from cultures induced for 4 h and separated on 12% SDS-PAGE. (A) Laddering pattern of O-antigen visible by silver stain indicates PglC is capable of complementing a CLM 37 *wecA*- mutant. *WecA* and PglC were expressed from the pIH38 and pRLM1 plasmids, with pEXT20 as vector control. (B) Western blot of the same *E. coli* O16 LPS samples using an anti-O16 antibody. (C) PglC does not complement the *S. enterica* MSS2 *wbaP*- strain, as no laddering is visible in the PglC lane. O-antigen was detected using an anti-*S. enterica* group B antibody. *WbaP* was expressed from the pJD132 plasmid. (D) PglC does not complement *E. coli* O9 *wbaP*- strain, lacking a strong ~20 kDa band. O-antigen was detected using an anti-*E. coli* O9 antibody. (E) PglC is capable of complementing the pEF33Δ*pglB* plasmid in a CLM37 *wecA*- strain background indicated by a strong ~11 kDa bacillosamine antibody reactive band. The unmodified pEF33 plasmid was used for

comparison (WT) as the native *pglB* was not yet cloned.

---

To determine if GalNAc was being transferred, we created a CLM37 strain bearing the *gne* UDP-GlcNAc to UDP-GalNAc epimerase from *C. jejuni*. Lacking an antibody, we utilised the soybean agglutinin (SBA) lectin to detect GalNAc attached to lipid A. The lectin blots were not successful, however, in detecting any transfer with our conditions, and we lacked suitable controls (data not shown). It is currently unknown if the *A. baumannii* ATCC 17978  $\Delta$ *pglC* mutant will be a suitable test for GalNAc specificity. Detection methods for the capsular polysaccharide and protein glycosylation are not sensitive to the reducing end sugar. It is unknown at this time if the second glycosyltransferase, or the CPS polymerase Wzy are specific for GalNAc. Attempting to complement the *A. baumannii* ATCC 17978  $\Delta$ *pglC* mutant with iGTs of known specificity will assist in establishing this specificity and its utility for further experiments.

### **Structural Analysis of PglC**

No crystal structure of PglC or any related enzymes currently exists in any database. Our collaborators' attempts at crystallisation have so far been unsuccessful. Despite strong expression of PglC (Fig. 2.5), and possessing only a single transmembrane domain, purification to homogeneity and subsequent crystallisation has been unsuccessful. Removal of the predicted transmembrane domain resulted in unstable protein and attempts to add solubilisation tags have been unsuccessful (personal correspondence, James Naismith). A thorough analysis of the multiple transmembrane domains of WecA have allowed for the identification of several critical sites with known homology and function for that enzyme family (Price and Momany 2005). The consensus sequences identified in WecA important to activity are not conserved in PglCs (Fig 2.2A), and consistent with this observation,

WecA, WbaP, and PglC all cluster differently (Fig 2.2B). The closest homologue to have previously been studied is WbaP. Site-directed mutagenesis of WbaP was performed, and a wide panel of critical residues were identified (Patel, Furlong, and Valvano 2010). Alignments comparing WbaP and other long iGTs to PglC and other short iGTs were used to develop a site-directed mutant panel with two main objectives: identify and mutate essential amino acids unique to the truncated iGTs, and attempt to modify substrate specificity through single amino acid substitution.

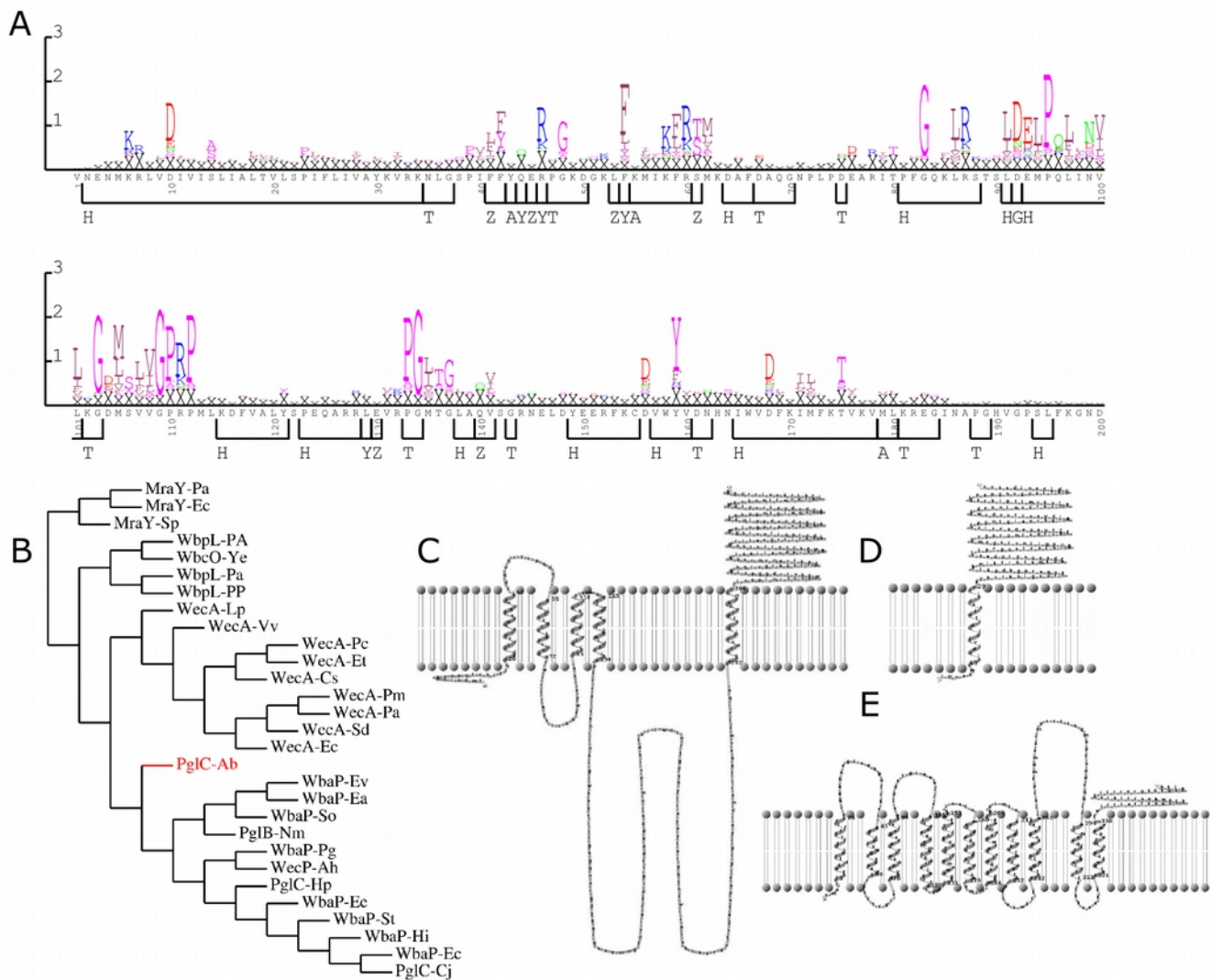

Figure 2.2. Bioinformatics summary for PglC homology. (A) Consensus sequence for PglC homologues generated by the SAMT08 Prediction Server. Large letters indicate highly conserved residues. (B) Homology tree of representative sample of iGTs. Clear clustering divides the WecA, WbpL, WbcO, and MraY 11 TM iGTs from the WbaP and PglC like iGTs. The *A. baumannii* ATCC 17978 PglC is highlighted in red. PglB is the *Neisseria meningitidis* iGT. (CDE) TMHMM prediction visualised by TMRPres2D of WbaP (C), PglC (D), and WecA (E) highlights the structural differences between these families.

Twenty-six amino acids were identified by this approach (Fig. 2.3). Mutants were made by site-directed mutagenesis, verified by sequencing and expression, and tested using the *in vivo* panel described earlier. Additional iGTs were added to validate that the assay conditions were not the cause of substrate promiscuity, and were only active in their expected assays. These were the WbaP of *S. enterica* for Gal transfer, WecA from *E. coli* K12 for GlcNAc, PglC<sub>Cj</sub> from *C. jejuni* 81-176 and PglB<sub>Nm</sub> from the pEF33 *N. meningitidis* plasmid for bacillosamine, and WreU from *Rhizobium etli* which transfers a QuiNAc intermediate (private communication, Dale Noel, Marquette University). PglB<sub>Nm</sub> did not appear to be active, possibly due to the presence of errors in the sequence.

```

gtgaatgaaaatatgaagcgttttagtagacatagtcatttctttaatagctttaactggt
V N E N M K R L V D I V I S L I A L T V 20
ctgtcgccaatactctgatagttgcttataaagtcgtaaaaaatttaggttcaccaata
L S P I L I V A Y K V R K N L G S P I 40
ttcttttaccagaagacacctggtaaggacggaaaattatttaaaatgattaagttcgt
F F Y Q E P G K D G K L F K M I K F R 60
tctatgaaagatgcatttgatgctcaaggaaatccattgccagatgaagctcgtattaca
S M K D A F D A Q G N P L P D E A R I T 80
ccatttgggtcaaaaattgcttcaactagctctggatgaaatgccgcagctcattaatgta
P E G Q K L R S T S L D E M P Q L I N V 100
ctaaaaggtgacatgagcctagtggtcgcgccaatgttaaaagactttgttgcttta
L K C D M S V V G P R P M L K D F V A L 120
tattcaccgaaacaagctcgtcgtttagaagttcgcccaggaatgacgggttttagctcag
Y S P E Q A R R L E V R P G M T G L A Q 140
gtaagtggtcgtaatgaacttgattatgaagaacgatttaagtgtgatgtatggtatgta
V S G R N E L D Y E E R F K C D V W Y V 160
gataaccacaacatttgggttgatttcaaaatcatgtttaaacagtcaaagtgatgta
D N H N I W V D F K I M F K T V K V M L 180
aaacgtgaaggaatcaatgctccagggcatgttgggccatctttatttaaaggtaatgat
K R E G I N A P G H V G P S L F K G N D 200
acccaagaaaatattgattcttctgttaagtaa
T Q E N I D S S V K -

```

Figure 2.3. Site-directed mutagenesis plan for PglC. Mutations are colour-coded according to their purpose. Blue are mutants towards the *C. jejuni* 81-176 PglC. Cyan are alanine substitution mutants in residues conserved only in short iGTs. Orange are alanine substitution mutants replicating data from Patel *et al.* 2010. Purple are mutants towards the *S. enterica* WbaP.



## Site-Directed Mutagenesis

Mutant	GlcNAc	Bac	Gal	Mutant	GlcNAc	Bac	Gal
WT	+	+	-	I98F	-	+	-
F25I	-	+	-	G103A	-	+	-
R34A	+	+	-	V107F	-	+	-
R46A	+	-	-	R111A	+	-	-
K58A	+	-	-	E124A	-	-	-
R60A	+	-	-	E124D	-	+	-
D75A	-	+	-	A139W	-	-	-
R78A	-	-	-	Q140A	+	+	-
F82A	+	-	-	R144A	+	+	-
R87A	+	-	-	D156A	-	-	-
D92A	-	-	-	Y159A	-	-	-
E93A	-	-	-	D168A	-	-	-
Q96A	+	-	-	K170A	+	+	-
I98A	+	+	-				

Table 2.1: Summary of site-directed mutant complementation of three *in vivo* transfer models. Sugar complemented is in abbreviated form, WT stands for wildtype PglC. Mutants are colour coded for why they are selected: Blue are mutations towards the *C. jejuni* 81-176 PglC; Cyan are conserved only in short iGTs; Orange had been mutated in WbaP (Patel, Furlong, and Valvano 2010); Purple are mutations towards the *S. enterica* WbaP. Green boxes indicate both complementation and expression in the respective model. Yellow boxes indicate a lack of complementation with approximately equal expression. Red boxes indicate a lack of complementation and expression.

Results of the SDM panel screen are shown in Fig. 2.4 and 2.5, and summarised in Table 2.1. Of the five mutants selected for being conserved only in the short iGTs, only E124A was essential, however, D75A lost the ability to transfer GlcNAc, while Q96A lost the ability to transfer bacillosamine. Of the amino acids mutated in WbaP (in parenthesis for ease of comparison), R78A (R368A), D92A (D382A), E93A (E383A), Y159A (Y449A) and D168A (D458A) were essential for activity in both; while I98A (F388A) was not disruptive in either. The D156A (D446A) mutant was

unusual in that it was non-essential in WbaP, but essential in PglC. Many mutants displayed altered behaviour, with R46A (R319A), K58A (K331A), R60A (R333A), F82A (F372A), R87A (R377A), Q96A (Q386A), and R111A (R401A) losing the ability to transfer bacillosamine; while G103A (G393), which was essential in WbaP, only lost GlcNAc transfer activity. Mutants made to resemble WbaP did not switch from *N*-acetylhexosamine preference, having no effect in the case of K170A, inactivation by A139W, and substrate restriction in E124D. Mutants to more closely resemble the *C. jejuni* 81-176 PglC (F25I, I98F, and V107F) were each sufficient to remove GlcNAc transfer activity. Of the original 26 mutants, 5 were selected for further study: F25I, R46A, D75A, I98F, and E124D. These were mutants demonstrating activity in one model but not the other as potentially indicative of substrate specificity change (Table 2.1). No mutants switched to hexose transfer, so this was not pursued further.

Comparing the *pglC* genes of three *A. baumannii* strains with known *O*-glycans (Scott et al. 2014) Arg2, 1225 and ATCC 17978 and a fourth, AYE that did not have *O*-glycans but has bacillosamine synthesis genes, most of the amino acids targeted for mutation are highly conserved (Fig 2.6). Mutations in three amino acids which affected substrate specificity when tested in the *in vivo* screen were present in 1225: F25Y, Q96E, and I98W; and in AYE: F26Y, Q97E, and I99W. F25 and Q96 both affected substrate specificity in our panel (F25I and Q96A) but were partially conserved in 1225, with similar sizes of side chains being present. Q96E is particularly interesting, as the alanine substitution abolishes bacillosamine transfer (Table 2.1), indicating that the glutamate side chain is necessary even if the charge is not. The I98W mutation also corresponds with the I98F mutation in our *in vivo* screen, which caused a switch to bacillosamine transfer. The difference in side chain size could be a factor in substrate specificity.

To provide additional confirmation of the preferential transfer of either bacillosamine or *N*-

acetylhexose, we planned to use a mass spectrometry approach to identify sugars transferred to a protein carrier. Mutants were expressed in the SDB1 *wecA-/waaL-* background (Garcia-Quintanilla et al. 2014) with plasmids for expressing the *N*-oligosaccharyltransferase PglB and AcrA carrier protein. For bacillosamine transfer we also included the pEF33 $\Delta$ *pglB* plasmid. Using MS would confirm the use of bacillosamine by mass, as separate from HexNAc transfer, to corroborate antibody detection results. Constructions of these strains is ongoing, with insufficient time to complete this experiment before thesis submission.

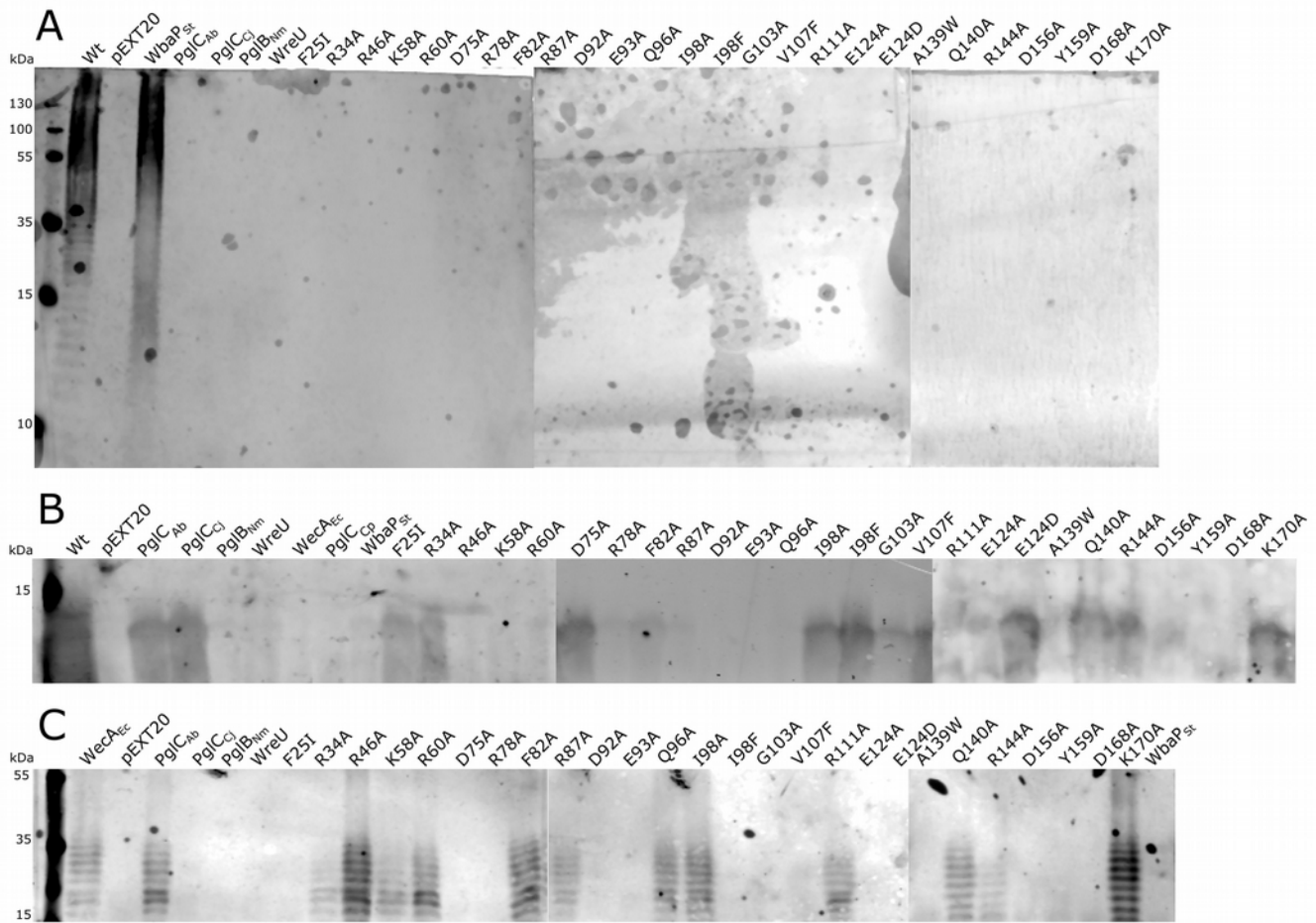

Figure 2.4. Complementation of *in vivo* models by site-directed mutants of the *A. baumannii* PglC, a selection of other iGTs of known specificity, and pEXT20 as vector control. All panels are collations of 3 or 4 Western blots from the same day. All blots contained positive and negative controls to assure quality. Loading was normalised by OD, with samples being Proteinase K digested for 4 hours at 55°C and run on SDS-PAGE. Induction was for 4 hours at 0.05% IPTG for all PglC mutants and run on a 12% SDS-PAGE. (A) No point mutants are capable of complementing the *S. enterica* MSS2 *wbaP*- *in vivo* model for galactose. Detected using an anti-*S. enterica* Group B antibody, with laddering indicating complementation. (B) Complementation of the *N. meningitidis* pEF33ΔpglB plasmid *in vivo* model for diNacBac is interrupted in some mutants. Bacillosamine is detected using the UOS-2 anti-bacillosamine antibody, with a reactive band indicating complementation. (C) Complementation of the

*E. coli* O16 *wecA*- *in vivo* model for GlcNAc is interrupted in some mutants. Laddering of LPS O-antigen subunits is detected using an anti-*E. coli* O16 antibody.

---

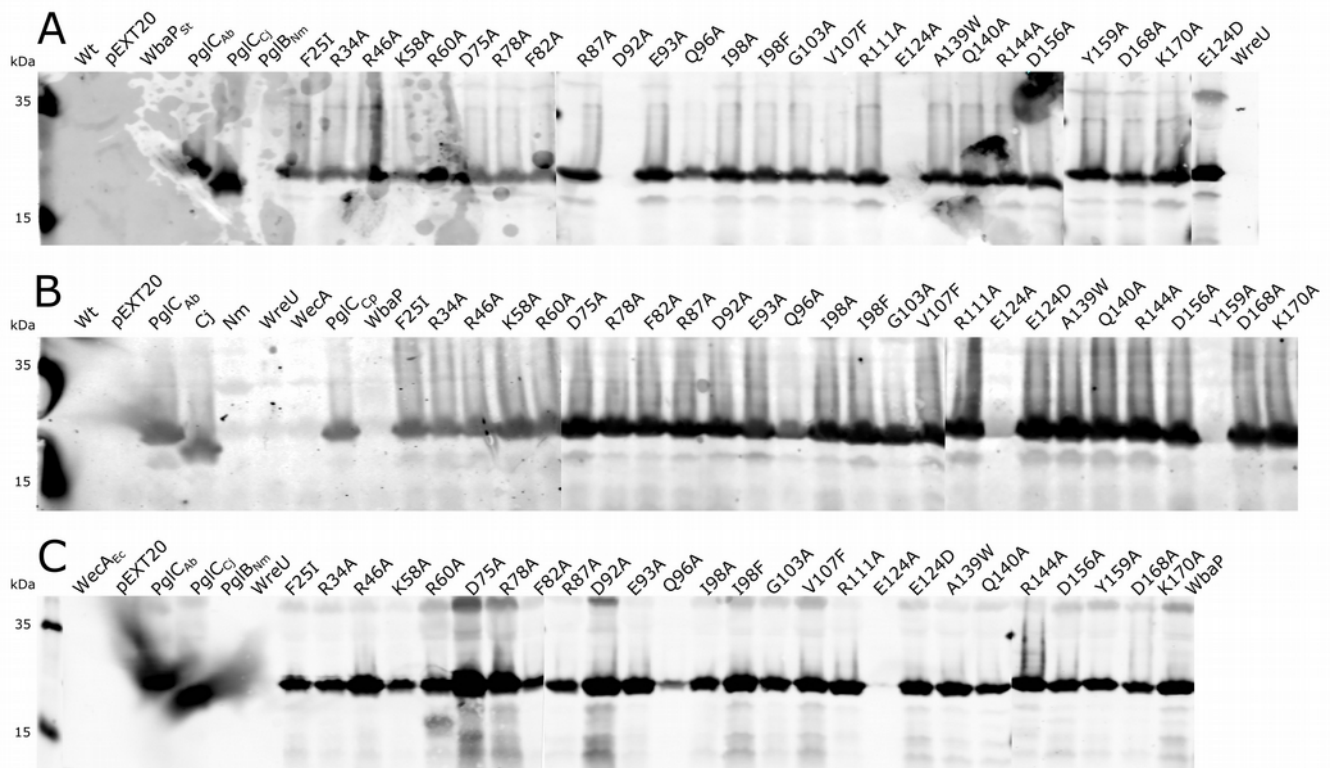

Figure 2.5. Expression of PglC mutants in the *in vivo* complementation models. All panels are collations of 3 or 4 Western blots from the same day. All blots contained positive and negative controls which were removed for ease of interpretation. After induction at 37°C for 4 hours with 0.05% IPTG, cell pellets normalised by OD were suspended in urea buffer and run on 12% SDS-PAGE. All were detected using a polyclonal anti-C-terminal His tag antibody. (A) Expression in the *S. enterica* MSS2 *wbaP*- *in vivo* model. (B) Expression in the *N. meningitidis* pEF33ΔpglB plasmid *in vivo* model. (C) *E. coli* O16 *wecA*- *in vivo* model.

```

17978  -MKRLVDIVISLIALTVLSPIFLIVAYKVRKKNLGSPIFFYQERPGKDGKLFKMIKFRSMK
1438   -MKRLVDIVISLIALTVLSPIFLIVAYKVRKKNLGSPIFFYQERPGKDGKLFKMIKFRSMK
1225   -MKRLVDIIASIALILLSPLIFVYAYKVRKKNLGS PVLFRQVRPGLHGKPFEMIKFRTMK
AYE    MLKRLLDIIIASVALILLSPLIFVYAYKVRKKNLGS PVLFRQVRPGLHGKPFEMIKFRTMK
      :***:**:*: :** :***::: *****:*****::* * ** .** *:*****:**

17978  DAFDAQGNPLPDEARITPFGQKLRSTSLDEMPQLINVLKGDMSSVVGPRPMLKDFVALYSP
1438   DAFDAQGNPLPDEARITPFGQKLRSTSLDEMPQLINVLKGDMSSVVGPRPMLKDFVALYSP
1225   DATDAQGNPLPDSERLTPEFGKMLRSSSLDEMPQLINVLKGDMSIVGPRPLLMEYLPYLNK
AYE    DATDAQGNPLPDSERLTPEFGKMLRSTSLDEMPQLINVLKGDMSIVGPRPLLMEYLPYLNK
      ** *****. *:***: **:*****.* **:*****:*****.* ::: **.

17978  EQARRLEVRPGMTGLAQVSGRNELDYEERFKCDVWYVDNHNIVWDFKIMFKTVKVMLKRE
1438   EQARRLEVRPGMTGLAQVSGRNELDYEERFKCDVWYVDNHNVWVDFKIMFKTVKVMLKRE
1225   EQAKRHDVRPGMTGHAQVNGRNAIGWEEKFKLDTWYVENRSLWLDFKIMLQTVKKVIAKD
AYE    EQAKRHDVRPGMTGHAQVNGRNAIGWEEKFKLDTWYVENRSLWLDFKIMLQTVKKVIAKD
      ***.* :***** **.*** : :**:* *.***:*.:*:*****:*** :: :

```

Figure 2.6. ClustalO alignment of four *A. baumannii* PglC proteins indicates biological relevance of SDM panel results. *A. baumannii* 17978 and Arg2 possess a HexNAc reducing sugar, and 1225 uses diNAcBac as determined by MS analysis of their *O*-glycans (Scott et al. 2014). AYE did not have an identified *O*-glycan, but possesses bacillosamine synthesis genes and is hypothesised to use diNAcBac. Amino acids mutated in this study are highlighted in yellow where conserved with the 17978 reference strain. Orange highlights partially conserved naturally occurring mutations which correspond to substrate specificity changes in the *in vivo* screen. Green highlights mutations in nonessential amino acids. Red highlights unconserved mutations which corresponded to substrate specificity changes in the *in vivo* screen.

### Development of an *in vitro* Assay

Typically, assays for iGT activity utilise radioactive or chemically modified sugars to detect transfer to un-labelled undecaprenylphosphate. These face serious limitations for scalability and so we sought to develop an alternative method for detecting activity which would not rely on modified substrates.

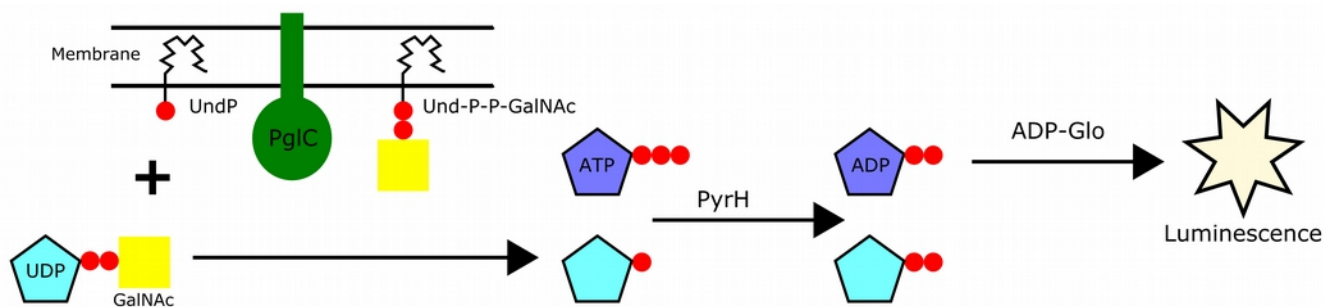

Figure 2.7. Schematic for *in vitro* PglC activity assay. PglC (Green) catalyses the addition of GalNac-1-P from UDP-GalNac to UndP to form Und-P-P-GalNac and UMP. UMP is then derivatised by PyrH to form UDP and ADP. ADP is then used by the ADP-Glo kit to generate luminescence. Phosphate transfer is represented using red circles.

One of the byproducts of the transfer reaction from nucleotide activated sugar on to undecaprenylphosphate is nucleoside monophosphate (XMP). The nucleoside monophosphate kinase enzyme can utilise ATP and XMP to form ADP and XDP. ADP is then detectable by either the NADH/lactate dehydrogenase coupled method, or the Promega ADP-Glo kit, which we chose to use as a proof of principle for its application to bacterial kinases (Fig 2.7). Commercially available bovine sourced NMPK (Roche) resulted in extremely high background and unreliable reproducibility of the NMPK mediated step and eventually lost activity (Fig 2.9A). To resolve this, the *E. coli* NMPK homologue, PyrH, was cloned with a His tag, purified (Fig 2.8) and used (Doig et al. 2013). Reproducibility was improved using fresh enzymes, but background remained high (Fig 2.9B). Changing the ratios of ATP:UMP did not have a strong effect on background, and the results were shown to not be dose-dependent in these conditions. Concentrations of ATP:UMP are within the linear range for ADP-Glo (Promega), but doubling the UMP added did not double the response (Fig 2.9B). The addition of GTP as a competitive inhibitor for the non-specific ATP degradation activity of PyrH dramatically improved background (Fig 2.9B). Further validation is required, as well as increasing the



purity of the protein.

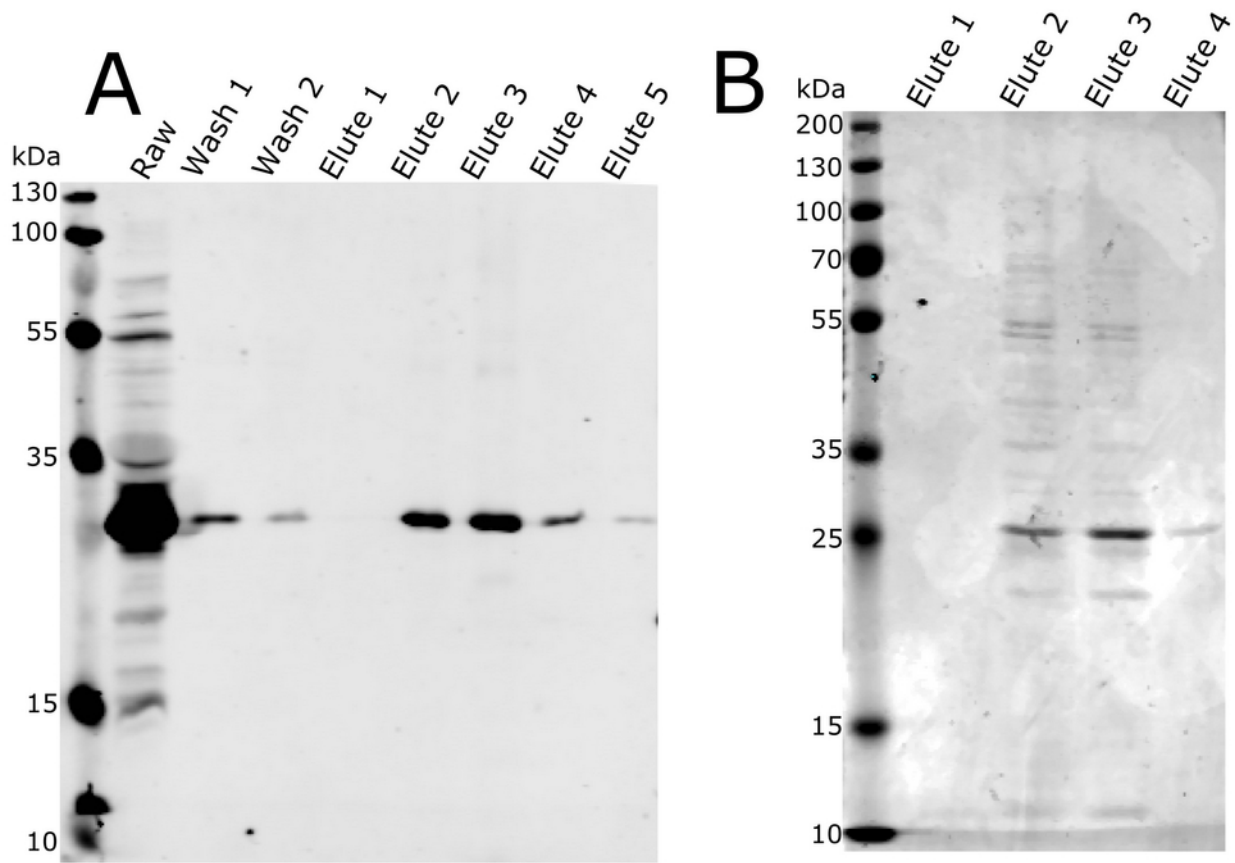

Figure 2.8. Purification of the PyrH nucleoside monophosphate kinase. (A) Western blot showing wash and elution fractions after His-Trap Column Purification of PyrH-6xHis. Detected using an anti-C-terminal His tag antibody. (B) Elution fractions visualised using a Coomassie stain to assess purity.

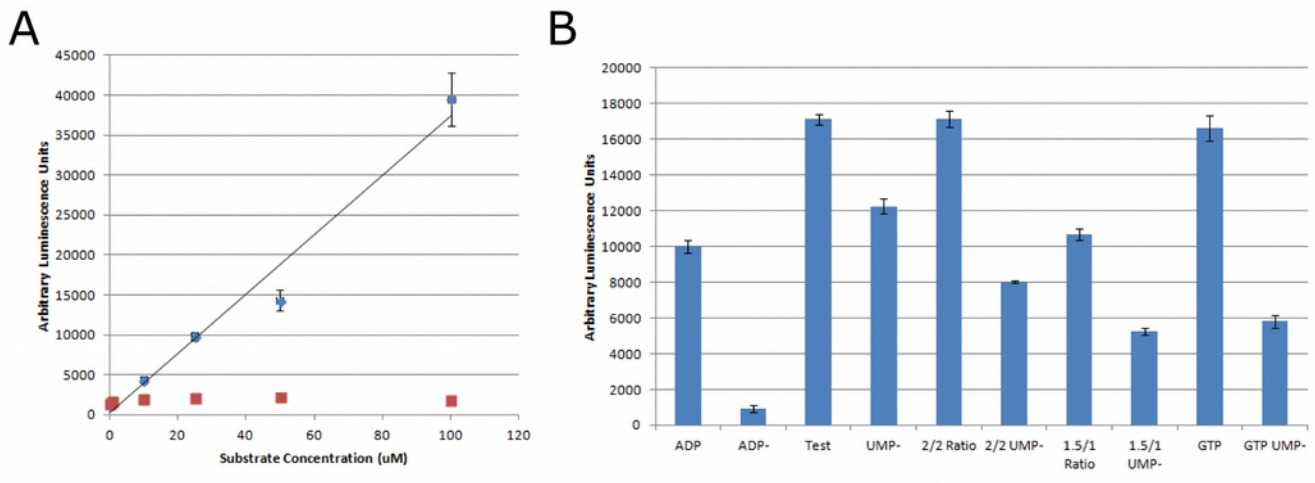

Figure 2.9. Results of *in vitro* PyrH activity using luminescence from ADP-Glo. Reactions were run for 3 hours at 37°C before being quenched using the ADP-Glo kit. Kinase detection reagent was added for 50 minutes then detected using a BioTek Synergy HT luminescence meter. All readings were made in quadruplicate and averaged, with the standard deviation of these measurements displayed by error bars. (A) Standard curve for ADP into arbitrary luminescence units (Blue dots), versus using UMP and bovine sourced NMPK (Red squares). R = 0.9729 for ADP curve. (B) Results using *E. coli* PyrH purified in lab, with changes in the ATP:UMP ratio (2:2 and 1.5:1), and addition of GTP as an inhibitor of non-specific activity. Positive control (ADP) used ADP instead of UMP and no enzyme. Negative control (ADP-) used no ADP or UMP and no enzyme. All test conditions were accompanied by a UMP negative control (UMP-) to assess their effect on background to signal ratio.

## ***Discussion***

Previous work by our group has demonstrated that *A. baumannii* possesses a linked protein glycosylation and capsular polysaccharide synthesis system (Lees-Miller et al. 2013) that are both essential for virulence (J A Iwashkiw et al. 2012; Russo et al. 2010), and as such make for attractive targets for intervention. While these loci are highly diverse (Scott et al. 2014; Kenyon and Hall 2013), they share a single protein, PglC, which was demonstrated to be essential (Lees-Miller et al. 2013). One of the questions identified in that work was the substrate specificity of the PglC enzyme. Typically, these enzymes are thought to have very high substrate specificity though structural homology can be a poor determinant (Price and Momany 2005). The conserved nature of PglC would seem to contrast with this due to two observations, first that a variety of sugars appear in *A. baumannii* reducing end sugars (Scott et al. 2014), and that in an *in vivo* assay to confirm its function PglC was potentially transferring sugars other than the anticipated GalNAc (Lees-Miller et al. 2013). To resolve this question we pursued two methods toward elucidating structural details of the PglC enzyme: *in vivo* panels of site-directed mutants, and an *in vitro* assay without radiolabeled substrates.

The single transmembrane domain and lack of significant homology to the WecA/MraY/WbcO iGTs prevents application of insights into the mechanisms of iGT activity from these enzymes (Anderson, Eveland, and Price 2000; Lehrer et al. 2007) to PglC. While this poses challenges to discerning important sites in PglC, it also removes one of the significant impediments to targeting these enzymes: close homologues exist in the eukaryotic protein glycosylation pathway. Previous work on WbaP established both that a C-terminal truncation was still active (Patel, Furlong, and Valvano 2010), consistent with PglCs naturally truncated structure, and that site-directed mutagenesis was a viable strategy for mapping important residues (Patel et al. 2012). We utilised a similar approach to screen for important residues in PglC. We identified that while the naturally truncated PglC shares some

conserved residues with WbaP, novel conserved residues found only in other short iGTs were also critical. Two groups of charged amino acids were critical to both proteins' function: R78/D92/E93 and D156/Y159/D168 that indicates catalytic relevance (Table 2.1). The majority of mutations which were identified as essential in WbaP, however, only modify substrate specificity when mutated in PglC. These could indicate the importance of folding rather than specific interactions to substrate specificity, a convenient explanation for the difficulty in identifying substrate specificity determinants in other iGTs. A new essential amino acid was identified in E124, with E124A abolishing protein expression, and conserved mutations effecting substrate specificity, furthering a structural explanation of substrate specificity. A mutation which was included as a control in the WbaP study, I98A was also non-essential by alanine substitution in PglC, however, phenylalanine substitution caused a change in substrate specificity, possibly due to the bulky headgroup. These observations are also supported in natural variants, as mutations causing switches in substrate specificity were identified in the PglC of *A. baumannii* 1225 (Fig 2.6), which was shown to utilise bacillosamine for its reducing end sugar, and *A. baumannii* AYE, which is hypothesised to do so (Scott et al. 2014). The I98W mutation is especially interesting as it is similar to the I98F produced by SDM to approximate the *C. jejuni* PglC, and natural variation in this amino acid depending on sugar specificity could explain why it was added as a control in the WbaP for its lack of conservation. Similarly, it highlights a potential weakness of alanine mutation as the sole determinant of protein function where small side chains are desirable for substrate interactions. Further validation is required for these mutants, though they provide an interesting first insight into possible mechanisms for this enzyme and the mechanism of its substrate promiscuity in *A. baumannii*. . The spread across the protein sequence, lack of structural or kinetic data, and a lack of conserved motifs from other proteins with similar functions makes narrowing down function difficult at this stage. While only E124A caused sufficient misfolding to abolish protein expression (Fig. 2.5), it is not possible to positively discern mutations in the active site from amino acids critical to protein

folding. The very high number of amino acids with measurable effects on protein function would be consistent with PglC being the minimum size required for iGT activity.

While some HTS have been developed for iGTs, these still involve radiolabeled substrates (Hyland and Anderson 2003) or chemically synthesised fluorescent sugars (Stachyra et al. 2004). Both of these make the process difficult. We instead focused on using a coupling reaction to the soluble byproduct UMP (Valvano 2011). While an indirect measure of PglC activity, it allows for a simple fluorometric or luminometric assay for activity. Two reactions are coupled together, first the nucleoside monophosphate kinase mediated reaction of  $UMP + ATP = UDP + ADP$  (Doig et al. 2013) followed by either the lactose dehydrogenase/NADH coupling reaction (Gosselin, Alhussaini, and Streiff 1994) or an ADP based luminescence assay kit from Promega, ADP-Glo (Promega). Progress was made on optimising the first half of the assay. Increasing the purity of PyrH preparation, and testing a combination of adjusting the ATP:UMP ratio and using GTP to reduce non-specific cleavage of ATP could further improve this half of the assay. Developing and optimising the second half will be an important piece of future work. Detergent optimisation will likely be required for PglC function, though examples exist including the use of nanodiscs (Hartley, Schneggenburger, and Imperiali 2013), as well as improved purification and resolubilisation of the undecaprenylphosphate substrate to assay sufficient quantities. Improving the signal-to-noise ratio may also be necessary, and could potentially be improved through the use of malachite green to detect free inorganic phosphate levels (Carter and Karl 1982). A functional, accessible, and simple HTS method for PglC activity would have multiple applications in developing inhibitors, understanding the limits and capabilities of this intriguing enzyme, and have broader use for other iGTs as well, since it does not rely on the specific sugar substrate.

## ***Materials and Methods***

### **Bacterial strains and growth conditions**

All strains were grown in LB media at 37°C with shaking at 200 r.p.m. unless otherwise stated. All strains used in this study are included in Table 2. Antibiotics were used as necessary for selection at the following concentrations: ampicillin 100  $\mu\text{g ml}^{-1}$ , tetracycline 5  $\mu\text{g ml}^{-1}$ , chloramphenicol 10  $\mu\text{g m}^{-1}$ , spectinomycin 80  $\mu\text{g ml}^{-1}$ , and kanamycin 50  $\mu\text{g ml}^{-1}$ . Inducers used for protein expression were IPTG at 20  $\mu\text{g ml}^{-1}$  and L-arabinose at 0.2%.

### **Site-Directed Mutagenesis**

All SDM used the DpnI method. Plasmid DNA, isolated by QIAGEN Miniprep Kits was amplified using complementary primers with Vent Thermopol polymerase (New England BioLabs) for PglC mutants, and PFU Turbo (Stratagene) for pEF33. All primers are contained in Table 2.2. PCR products were purified by ethanol precipitation, digested with DpnI (New England Bio Labs) for 3 hours at 37°C, purified again by ethanol precipitation and transformed into electrocompetent cells. Transformants were sequenced to verify mutation.

### **LPS Extraction and SDS-PAGE**

Cultures were reinoculated, grown to approximately 1 OD and induced with IPTG for either 4 h or overnight. Cells were pelleted and LPS was either extracted by the hot phenol method (Marolda et al. 1990), or resuspended at 20 OD/mL in 1M urea buffer with 2%  $\beta$ -mercaptoethanol and digested with Proteinase K at 55°C for 4 h. Samples were separated via SDS-PAGE. LPS was visualised by silver staining (Tsai and Frasch 1982), or through Western blotting with strain specific antibodies as described. Whole protein samples for determining PglC expression were taken from the same cultures, resuspended at 20 OD  $\text{mL}^{-1}$  in urea buffer.

## **Bioinformatic Tools**

Consensus mapping was done using the SAMT08 server (Karplus 2009). Phylogenetic tree was constructed using Phylogeny.fr (Dereeper et al. 2008). TM predictions used the TMHMM prediction server (CBS), and were visualised using TMRPres2D (Spyropoulos et al. 2004). Alignments used ClustalO. Genes used in alignments are described in Table 2.4.

## **Cloning and Purification Purification of PyrH**

PyrH was amplified from *E. coli* K12 genomic DNA isolated using QIAGEN Blood and Tissue Kit, primers with EcoRI and BamHI cut sites, and a 6xHis tag were used (Table 2.2), and amplified with Vent Thermopol Polymerase (New England BioLabs). PCR product was cloned into pEXT20, sequenced, and verified for expression following the same protocol as for PglC. For purification, overnight cultures were reinoculated into 1L, grown to 1 OD, induced with IPTG, pelleted, and lysed with a Cell Disruptor. Lysate was centrifuged at 10 000 g for 15 min to remove debris, then at 100 000 g for 1 h to remove membrane. Loading buffer was added to bring the lysate to 30 mM imidazole, 200 mM NaCl in 50 mM Tris-HCl at pH 7 and applied to a pre-equilibrated His-Trap Ni-NTA column. The column was then washed with 5 volumes of buffer at 50 mM imidazole. Elution was accomplished with 2 column volumes of elution buffer at 200 mM imidazole. Protein containing fractions were identified by Coomassie, and confirmed later by Western blot, combined and desalted on a PD10 column (GE) into a final buffer of 50 mM Tris-HCl at pH 7.5.

## **Enrichment of Undecaprenylphosphate**

CLM 37 wecA- cells were grown overnight in 1 L LB broth, harvested, and UndP was enriched in a modified protocol for purifying archaeal dolichol (Kaminski et al. 2010). Cells were harvested at 8

000 g for 30 min at 4°C and resuspended in 25 mL double-distilled water. Methanol and chloroform were added to the cell extract to yield a methanol-to-chloroform-to-cell extract ratio of 2:1:0.8. After stirring for 24 h at room temperature, the mixture was centrifuged at 5 000 g for 10 min at 4°C to remove cell debris. The supernatant fractions were collected, combined, and filtered through Whatmann filter paper to remove debris. Chloroform and double-distilled water were added to the filtrate to yield a chloroform-to-DDW-to-filtrate ratio of 1:1:3.8 in a separating funnel. After separation, the lower clear organic phase, containing the total lipid extract, was collected into a round-bottomed flask and evaporated in a rotary evaporator at 35°C. Lipids were resolubilised in 4 mL 3% Triton X-100 using vigorous mixing.

### **UMP Activity Assay Conditions**

PyrH activity was assayed in 20  $\mu$ L reactions with the same reaction conditions as previously tested (Bucurenci et al. 1998): 50 mM Tris-HCl pH 7.5, 50 mM KCl, 2 mM  $MgCl_2$ , but with the addition of 0.5% lipid extract (see above) to include detergents and lipid in preparation for future application of the assay. Final ATP concentration was 0.2 mM, with 0.5 mM GTP used for inhibition. Reactions were equilibrated for 15 minutes before the addition of UMP to a final concentration of 0.1 mM, and then 2  $\mu$ L of PyrH was added. After incubation for 3 h at 37°C, 5  $\mu$ L of Buffer B (100mM  $MgCl_2$ , 0.5 mg  $mL^{-1}$  BSA) was added to bring the final concentrations to 40 mM Tris-HCl pH 7.5, 40 mM KCl, 20 mM  $MgCl_2$ , and 0.1 mg  $mL^{-1}$  BSA. 25 $\mu$ L of ADP-Glo reagent was then added and incubated at room temperature for 40 min, followed by 50  $\mu$ L of Kinase Detection Reagent at which point the reaction was mixed by pipetting and aliquoted into a 384 plate for reading, and incubated at room temperature in the dark for 50 min. Luminescence was measured with a BioTek HT Synergy using the Plug and Hole filters for luminescence.



Primer	Sequence	Comment
Pg1CF25I	gttctgtcgcgaataAttctgatagttgcttat	And reverse complement
Pg1CR34A	gttgcttataaagtcGctaaaaatttagttca	And reverse complement
Pg1CR46A	ttcttttaccagaagGCacctggtaaggacgga	And reverse complement
Pg1CK58A	ttattttaaagattGCgttccgttctatgaaagatgc	And reverse complement
Pg1CR60A	aaaatgattaagttcGcttctatgaaagatgcatttg	And reverse complement
Pg1CD75A	ggaaatccattgccagCtgaagctcgtattaca	And reverse complement
Pg1CR78A	ttgccagatgaagctGctattacaccatttggt	And reverse complement
Pg1CF82A	gctcgtattacaccaGctggctcaaaaattgctg	And reverse complement
Pg1CR87A	tttggctcaaaaattgGcttcaactagtctggat	And reverse complement
Pg1CD92A	cgttcaactagtctggCtgaatgccgcagctc	And reverse complement
Pg1CE93A	tcaactagtctggatgCaatgccgcagctcatt	And reverse complement
Pg1CQ96A	ctggatgaaatgccgGCgtcattaatgtacta	And reverse complement
Pg1CI98A	gaaatgccgcagctcGctaatgtactaaaaggt	And reverse complement
Pg1CI98F	gaaatgccgcagctcTttaatgtactaaaaggt	And reverse complement
Pg1CG103A	attaatgtactaaaagCtgacatgagcgtagtg	And reverse complement
Pg1CV107F	gacatgagcTtTgtgggtccg	And reverse complement
Pg1CR111A	gtagtgggtccgGctccaatgtttaaag	And reverse complement
Pg1CE124A	gctttatattcaccgcCacaagctcgtcgttta	And reverse complement
Pg1CE124D	gctttatattcaccgcaCcaagctcgtcgttta	And reverse complement
Pg1CA139W	gacgggtttaTGGcaggtaagtggctc	And reverse complement
Pg1CQ140A	cgggttagctGCggttaagtggctc	And reverse complement
Pg1CR144A	gctcaggtaagtggGctaatgaacttgattat	And reverse complement
Pg1CD156A	gaacgatttaagtgtgCtgtatggtatgtagat	And reverse complement
Pg1CY159A	aagtgtgatgtatggCctgtagataaccacaac	And reverse complement
Pg1CD168A	cacaacatttgggttgCtttcaaaatcatgttt	And reverse complement
Pg1CK170A	atthgggtgatttcGcaatcatgtttaaaca	And reverse complement
pEF33pg1BFwd	CCGATAACGGCAGTTATCATTATCACGCGAAAGGGGCATGG	And reverse complement
PyrHFwd	CGCGGAATTCATGGCTACCAATGCAAAACCC	EcoRI Site
PyrHRev	TTAAGGATCCTTAGTGATGGTGATGGTGATGGTGATGTTCCGTGATTAAAGTCCCTTC	BamH1 Site and 6xHistag

Table 2.2. Primers used in this study. For PglC SDM, capitalised nucleic acids are mutated.

Strain or Plasmid	Comment	Source
<i>E. coli</i> CLM 37	<i>wecA</i> -	Lab strain
pACYCpgl	<i>C. jejuni</i> heptasaccharide	(Wacker et al. 2002)
pACYCpglC	<i>C. jejuni</i> heptasaccharide mutant	(Linton et al. 2005)
pRLM1	<i>A. baumannii</i> PglC with IPTG induction	(Lees-Miller et al. 2013)
pEXT20	Empty vector for <i>E. coli</i> expression	
pEF33	<i>N. meningitidis</i> bacillosamine	Koomey Lab
pEF33ΔpglB	<i>N. meningitidis</i> bacillosamine mutant	This work
pJD132	<i>S. typhimurium</i> WbaP	(Saldias et al. 2008)
<i>S. typhimurium</i> LT2	Wt	ibid
<i>S. typhimurium</i> MSS2	<i>wbaP</i> -	ibid
<i>E. coli</i> O9	Wt	(Drummelsmith and Whitfield 1999)
<i>E. coli</i> O9 <i>wbaP</i> -		ibid
pIH38	<i>E. coli</i> WecA	Lab Strain
pLS5	<i>R. etli</i> WreU	Dale Noel, Marquette University
pCP0465	<i>C. perfringens</i> WchA	Unpublished
pRLM3	IPTG inducible PyrH	This work

Table 2.3. Strains and plasmids used in this study. Does not include all 26 SDM mutants of pRLM1.

WbaP-Ec: *Escherichia coli* AAD21565  
 WbaP-Ev: *Erwinia carotovora* CBJ46616  
 WbaP-Pg: *Porphyromonas gingivalis* ATCC 33277 BAG34415  
 WbaP-St: *Salmonella enterica* subsp. *enterica* serovar Typhimurium str. LT2 NP\_461027  
 WbaP-Ee: *Enterobacter cloacae* subsp. *cloacae* ATCC 13047 YP\_003613836  
 WbaP-Ea: *Erwinia amylovora* ATCC BAA-2158 CBX81132  
 WbaP-So: *Serratia odorifera* 4Rx13 ZP\_06189355  
 WbaP-Hi: *Haemophilus influenzae* Rd KW20 NP\_439033  
 WecP-Ah: *Aeromonas hydrophila* ABX39510  
 WecA-Sd: *Shigella dysenteriae* Sd197 YP\_405383  
 WecA-Et: *Edwardsiella tarda* ATCC 23685 ZP\_06716201  
 WecA-Pc: *Pectobacterium carotovorum* subsp. *carotovorum* WPP14 ZP\_03829856  
 WecA-Fm: *Proteus mirabilis* HI4320 YP\_002153001  
 WecA-Pa: *Photobacterium asymbiotica* subsp. *asymbiotica* ATCC 43949 YP\_003042971  
 WecA-Cs: *Cronobacter sakazakii* ATCC BAA-894 YP\_001439802  
 MraY-Pa: *Pseudomonas aeruginosa* AAG22121  
 MraY-Sp: *Streptococcus pneumoniae* AFC91887  
 MraY-Ec: *Escherichia coli* UMNK88 YP\_006131916  
 WbcO-Ye: *Yersinia enterocolitica* CAA87703  
 WbpL-Pa: *Pseudomonas aeruginosa* AAF72959  
 WbpL-PP: *Pseudomonas aeruginosa* PAO1 AAC45866  
 WbpL-PA: *Pseudomonas aeruginosa* AAF23990  
 PglC-Ab: *Acinetobacter baumannii* ATCC 17978 ABO10556  
 PglC-Cj: *Campylobacter jejuni* subsp. *jejuni* 81-176 AAD51385  
 PglB-Nm: *Neisseria meningitidis* 96037 EQC97461.1  
 PglC-Hp: *Helicobacter pullorum* NCTC 12824 ADM36006  
 WecA-Vv: *Vibrio vulnificus* NBRC 15645 = ATCC 27562 ADO64246  
 WecA-Lp: *Legionella pneumophila* CAB65202  
 WecA-Ec: *Escherichia coli* AAG26342

Table 2.4. Sequences of iGTs used for bioinformatics analysis with annotation on tree, strain, and accession number. *Neisseria meningitidis* is annotated as PglC for consistency.

## Exploring the *Acinetobacter baumannii* Glycome: Conclusions

The rise of *Acinetobacter baumannii* as a pathogen of concern in the hospital environment (Peleg, Seifert, and Paterson 2008) has pushed it into the spotlight for developing new antibacterial strategies. Unlike many dangerous pathogens, *A. baumannii* does not appear to possess deliberate strategies for infecting the host, but instead is able to maintain infection through its persistence in harsh conditions. Resistance to antimicrobial peptides, defences against amoebas, and survival in nutrient limiting conditions are common stress factors that *A. baumannii* must survive in either environment, especially with immunodeficient hosts lacking strong adaptive responses. Surface carbohydrates are a primary component of those defences, with several studies identifying their importance in *A. baumannii* pathogenesis (Umland et al. 2012; Russo et al. 2010; Lees-Miller et al. 2013; J A Iwashkiw et al. 2012; Choi et al. 2009). This work contributes to that knowledge by identifying the pathway for carbohydrate utilisation in *A. baumannii*. In addition to its identification, we were also able to demonstrate that *A. baumannii* uses a novel bifurcated pathway for producing surface carbohydrates. *A. baumannii* is able to produce a highly protective capsular polysaccharide and *O*-linked glycoproteins from the same pentasaccharide. It does so through an unconventional use of the modular components of carbohydrate synthesis (Hug and Feldman 2011). Beyond simply being novel, this bifurcated pathway also provides further evidence to the diversity of protein glycosylation in bacteria, which has been a hot topic since its discovery, with an ever increasing number of bacteria glycosylating proteins (Nothaft and Szymanski 2010; Jeremy A Iwashkiw et al. 2013). It also demonstrates an unusual behaviour in pathogen's capsular polysaccharide. Immune evasion and host response modification have been identified as primary driving forces for diversity in surface carbohydrates (Settem et al. 2013), with some bacteria producing numerous glycans on their surface (Holst Sørensen et al. 2012; Guerry and Szymanski 2008; Krinos et al. 2001) in order to modulate and evade host immune responses. Rather than engage in this mimicry, diversity, and stealth *A. baumannii* instead relies on a single carbohydrate across its entire cell surface that is necessary to its survival in the host. While unusual in the context of

deliberate pathogens, the lack of a toolbox for dealing with host defences highlights the opportunistic nature of *A. baumannii* infection. Through the production of a sufficiently robust defence mechanism, it can survive well enough to cause dangerous infection, with the human body simply being another hostile environment it must overcome. Understanding *A. baumannii* virulence as the direct product of its exceptional environmental persistence also highlights why it has been such a dangerous pathogen: not its disease potential but its tenacity in surviving in the hospital. Preventing its further spread and danger will require finding ways to disable or evade the carbohydrate shield of *A. baumannii*. Fortunately, despite the strength of *A. baumannii*'s defences, the use of a single mechanism is also a vulnerability. Such a barrier provides an advantage when faced with incoherent and uncoordinated attacks by the environment, but it also results in *A. baumannii* being vulnerable if an Achilles' Heel can be found. Two major strategies of interest are then to develop vaccines against the CPS of *A. baumannii* and targeting critical enzymes in the pathway with antibiotics.

Surface carbohydrates generally make for attractive vaccination targets due to their exposure and immunogenicity (Hug and Feldman 2011; Garcia-Quintanilla et al. 2014). Developing an effective vaccine against *A. baumannii* is rendered difficult both by its infecting already immunodeficient patients who would not have a robust response, but also that despite the conservation of the general structure of its carbohydrates at a genetic level, but also the ubiquitousness of negatively charged branches, *A. baumannii* has considerable diversity between strains in its surface carbohydrates (Kenyon and Hall 2013; Scott et al. 2014). Both endproducts and much of the machinery are diverse and subject to change with one exception: PglC, is conserved across known isolates, and was also identified as essential (Lees-Miller et al. 2013). A cytoplasmic protein, it does not satisfy the criteria for a vaccine target but instead has interesting possibilities as a new antibiotic target. In addition to being conserved in *A. baumannii*, PglC also lacks eukaryotic homology and is present in many bacteria. Previous attempts to disrupt iGTs have focussed on MraY and WecA, with antibiotics such as tunicamycin which also disrupted eukaryotic homologues (Price and Momany 2005). Despite this, significant challenges

still exist to antibiotic development. No crystal structure is available to pursue rational drug design, and the reaction mechanism is unknown. To begin the process of antibiotic development, we have attempted to establish tests for characterising PglC. The most important component of that is developing a luminometric assay for activity that would be amenable to high-throughput screening that is not available with current radiometric techniques. We have made progress towards developing one of the two steps necessary for this assay to derivatise the UMP byproduct into measurable ADP. If subsequent steps can successfully demonstrate PglC activity this will provide a platform for high-throughput screening. It will also allow for kinetic assays without the use of radioactive substrates, and would be amenable to testing other similar enzymes and evaluating *in vitro* reactions to synthesise designer glycans. As such it has considerable biotechnological utility to better understand carbohydrate synthesis.

In addition to the possible applications in biotechnology, the PglC enzyme provides a useful platform for understanding the initiator glycosyltransferases. Despite their importance, little is known about their functioning because of the difficulty of studying their activity and structure. The 11 TM iGTs are likely ancient proteins, given their presence in all domains of life, catalysing vital reactions for cell surface structure. The 1 TM iGTs on the other hand, are unique to bacteria. As such, their evolution and origins pose interesting questions: how and why did bacteria develop their own, additional glycosylation enzymes, and how they are modified to transfer a variety of sugars. Unlike the 11 TM iGTs with common domains that hint at their function, such as Mg binding, and isoprenyl transferase domains, the 1 TM iGTs lack domain homology with other proteins. How they overcome common challenges and accomplish similar chemistries will provide insights not only into PglC, but also its substrates. The small size of PglC is both a help and hinderance in this respect. The small size narrows down the range of possible sites, and likely represents a very minimal approach to accomplishing the initiation step. Small changes unrelated to the actual mechanism can affect protein function as a result, as evidence in preliminary SDM experiments having very high numbers of amino acids affecting

function. Measuring specificity is interesting here, because these systems have only been tested with the transfer of one sugar before (Patel, Furlong, and Valvano 2010). Broadening the range may reveal mutations which alter kinetics, rather than simply abolish function. Especially given that the mechanism for specificity is an elusive problem (Price and Momany 2005), this helps to identify factors that are more holistic than direct interactions. Typically, substrate specificity is well conserved within the structural homology classification, except in the single TM domain iGTs, which transfer a wide variety of sugars. Modifications to substrate specificity with identifiable origins have largely related to modifications of the sugars, not the sugars themselves, as is the case in MraY. Single amino acid substitutions switching substrate specificity represents the first time that sugar promiscuity has been demonstrated and opens the possibility for better understanding how iGTs select from the numerous nucleotide-activated sugars that are available to them. Beyond testing in the lab, PglC also represents a unique opportunity in studying natural diversity. Within *A. baumannii*, the two *in vivo* systems are replicated in different strains: notably 1225 which was demonstrated to use bacillosamine rather than HexNAc, and strain AYE, which while not having identifiable glycoproteins also encodes bacillosamine synthesis genes (Scott et al. 2014). Moving beyond just the *A. baumannii* PglCs, examining natural diversity provides an excellent platform for comparative genomics to understand substrate specificity. The major limitations of this approach is that many annotated strains do not have proven glycan structures, and a great deal of uncertainty still exists even with known glycans due to epimerisation. They provide however, a wealth of potential modifications that can be easily tested in laboratory conditions. Narrowing down the mechanism for substrate specificity to even vague regions will still be an improvement to the field. The wide diversity of PglC and similar enzymes therefore provides a lot of opportunities for further research that has been initiated by this work.

### **Bibliography**

- Abbott, Yvonne, Rebecca O'Mahony, Nola Leonard, P Joseph Quinn, Tanny van der Reijden, Lenie Dijkshoorn, and Séamus Fanning. 2005. "Characterization of a 2.6 Kbp Variable Region within a Class 1 Integron Found in an *Acinetobacter Baumannii* Strain Isolated from a Horse." *The Journal of Antimicrobial Chemotherapy* 55 (3): 367–70. doi:10.1093/jac/dkh543.
- Adams, Mark D, Karrie Goglin, Neil Molyneaux, Kristine M Hujer, Heather Lavender, Jennifer J Jamison, Ian J MacDonald, et al. 2008. "Comparative Genome Sequence Analysis of Multidrug-Resistant *Acinetobacter Baumannii*." *Journal of Bacteriology* 190 (24): 8053–64. doi:10.1128/JB.00834-08.
- Amer, A, and M Valvano. 2001. "Conserved Amino Acid Residues Found in a Predicted Cytosolic Domain of the Lipopolysaccharide Biosynthetic Protein WecA Are Implicated in the Recognition of UDP-N-Acetylglucosamine." *Microbiology (Reading, England)* 147 (Pt 11): 3015–25. <http://www.ncbi.nlm.nih.gov/pubmed/11700352>.
- Amer, A, and Miguel Valvano. 2002. "Conserved Aspartic Acids Are Essential for the Enzymic Activity of the WecA Protein Initiating the Biosynthesis of O-Specific Lipopolysaccharide and Enterobacterial Common Antigen in *Escherichia Coli*." *Microbiology (Reading, England)* 148 (Pt 2): 571–82. <http://www.ncbi.nlm.nih.gov/pubmed/11832520>.
- Anderson, M S, S S Eveland, and N P Price. 2000. "Conserved Cytoplasmic Motifs That Distinguish Sub-Groups of the Polyprenol phosphate:N-Acetylhexosamine-1-Phosphate Transferase Family." *FEMS Microbiology Letters* 191 (2): 169–75. <http://www.ncbi.nlm.nih.gov/pubmed/11024259>.
- Antunes, Luísa C S, Paolo Visca, and Kevin J Towner. 2013. "Acinetobacter Baumannii: Evolution of a Global Pathogen." *Pathogens and Disease*, December. doi:10.1111/2049-632X.12125.
- Barr, K, P Nunes-Edwards, and P D Rick. 1989. "In Vitro Synthesis of a Lipid-Linked Trisaccharide Involved in Synthesis of Enterobacterial Common Antigen." *Journal of Bacteriology* 171 (3): 1326–32. <http://www.pubmedcentral.nih.gov/articlerender.fcgi?artid=209749&tool=pmcentrez&rendertype=abstract>.
- Bergogne-Bérézin, E, and K J Towner. 1996. "Acinetobacter Spp. as Nosocomial Pathogens: Microbiological, Clinical, and Epidemiological Features." *Clinical Microbiology Reviews* 9 (2): 148–65. <http://www.pubmedcentral.nih.gov/articlerender.fcgi?artid=172888&tool=pmcentrez&rendertype=abstract>.
- Bernatchez, Stéphane, Christine M Szymanski, Noboru Ishiyama, Jianjun Li, Harold C Jarrell, Peter C Lau, Albert M Berghuis, N Martin Young, and Warren W Wakarchuk. 2005. "A Single Bifunctional UDP-GlcNAc/Glc 4-Epimerase Supports the Synthesis of Three Cell Surface Glycoconjugates in *Campylobacter Jejuni*." *The Journal of Biological Chemistry* 280 (6): 4792–4802. doi:10.1074/jbc.M407767200.
- Bouhss, A, D Mengin-Lecreulx, D Le Beller, and J Van Heijenoort. 1999. "Topological Analysis of the *MraY* Protein Catalysing the First Membrane Step of Peptidoglycan Synthesis." *Molecular*



*Microbiology* 34 (3): 576–85. <http://www.ncbi.nlm.nih.gov/pubmed/10564498>.

Brandish, P E, M K Burnham, J T Lonsdale, R Southgate, M Inukai, and T D Bugg. 1996. “Slow Binding Inhibition of Phospho-N-Acetylmuramyl-Pentapeptide-Translocase (Escherichia Coli) by Mureidomycin A.” *The Journal of Biological Chemistry* 271 (13): 7609–14. <http://www.ncbi.nlm.nih.gov/pubmed/8631795>.

Bucurenci, Nadia, Lidia Serina, Cristina Zaharia, Stephanie Landais, Antoine Danchin, and Octavian Barzu. 1998. “Mutational Analysis of UMP Kinase from Escherichia Coli.” *J. Bacteriol.* 180 (3): 473–77. <http://jb.asm.org.login.ezproxy.library.ualberta.ca/content/180/3/473.long>.

Bugg, T D, and P E Brandish. 1994. “From Peptidoglycan to Glycoproteins: Common Features of Lipid-Linked Oligosaccharide Biosynthesis.” *FEMS Microbiology Letters* 119 (3): 255–62. <http://www.ncbi.nlm.nih.gov/pubmed/8050708>.

Burrows, L. L., D. F. Charter, and J. S. Lam. 1996. “Molecular Characterization of the Pseudomonas Aeruginosa Serotype O5 (PAO1) B-Band Lipopolysaccharide Gene Cluster.” *Molecular Microbiology* 22 (3): 481–95. doi:10.1046/j.1365-2958.1996.1351503.x.

Bushell, Simon R, Iain L Mainprize, Martin A Wear, Hubing Lou, Chris Whitfield, and James H Naismith. 2013. “Wzi Is an Outer Membrane Lectin That Underpins Group 1 Capsule Assembly in Escherichia Coli.” *Structure (London, England : 1993)* 21 (5). Elsevier: 844–53. doi:10.1016/j.str.2013.03.010.

Carter, Stephen G., and Daniel W. Karl. 1982. “Inorganic Phosphate Assay with Malachite Green: An Improvement and Evaluation.” *Journal of Biochemical and Biophysical Methods* 7 (1): 7–13. doi:10.1016/0165-022X(82)90031-8.

Castric, P, F J Cassels, and R W Carlson. 2001. “Structural Characterization of the Pseudomonas Aeruginosa 1244 Pilin Glycan.” *The Journal of Biological Chemistry* 276 (28): 26479–85. doi:10.1074/jbc.M102685200.

Choi, Alexis H K, Leyla Slamti, Fikri Y Avci, Gerald B Pier, and Tomás Maira-Litrán. 2009. “The pgaABCD Locus of Acinetobacter Baumannii Encodes the Production of Poly-Beta-1-6-N-Acetylglucosamine, Which Is Critical for Biofilm Formation.” *Journal of Bacteriology* 191 (19): 5953–63. doi:10.1128/JB.00647-09.

Cunneen, Monica M, Bin Liu, Lei Wang, and Peter R Reeves. 2013. “Biosynthesis of UDP-GlcNAc, UndPP-GlcNAc and UDP-GlcNAcA Involves Three Easily Distinguished 4-Epimerase Enzymes, Gne, Gnu and GnaB.” *PloS One* 8 (6): e67646. doi:10.1371/journal.pone.0067646.

Dal Nogare, A. R., N. Dan, and M. A. Lehrman. 1998. “Conserved Sequences in Enzymes of the UDP-GlcNAc/MurNAc Family Are Essential in Hamster UDP-GlcNAc:dolichol-P GlcNAc-1-P Transferase.” *Glycobiology* 8 (6). OXFORD UNIV PRESS, GREAT CLARENDON ST, OXFORD OX2 6DP, ENGLAND: 625–32. doi:10.1093/glycob/8.6.625.

Dereeper, A, V Guignon, G Blanc, S Audic, S Buffet, F Chevenet, J-F Dufayard, et al. 2008.

“Phylogeny.fr: Robust Phylogenetic Analysis for the Non-Specialist.” *Nucleic Acids Research* 36 (Web Server issue): W465–69. doi:10.1093/nar/gkn180.

- DiGiandomenico, A, M J Matewish, A Bisailon, J R Stehle, J S Lam, and P Castric. 2002. “Glycosylation of *Pseudomonas Aeruginosa* 1244 Pilin: Glycan Substrate Specificity.” *Molecular Microbiology* 46 (2): 519–30.
- Doig, Peter, Elise Gorseth, Tory Nash, Arthur Patten, Ning Gao, and Carolyn Blackett. 2013. “Screening-Based Discovery of the First Novel ATP Competitive Inhibitors of the *Staphylococcus Aureus* Essential Enzyme UMP Kinase.” *Biochemical and Biophysical Research Communications* 437 (1). Elsevier Inc.: 162–67. doi:10.1016/j.bbrc.2013.06.060.
- Drummel-Smith, J, and C Whitfield. 1999. “Gene Products Required for Surface Expression of the Capsular Form of the Group 1 K Antigen in *Escherichia Coli* (O9a:K30).” *Molecular Microbiology* 31 (5): 1321–32.
- Faridmoayer, Amirreza, Messele A Fentabil, Dominic C Mills, John S Klassen, and Mario F Feldman. 2007. “Functional Characterization of Bacterial Oligosaccharyltransferases Involved in O-Linked Protein Glycosylation.” *Journal of Bacteriology* 189 (22): 8088–98. doi:10.1128/JB.01318-07.
- Feldman, Mario F., Cristina L. Marolda, Mario A. Monteiro, Malcolm B. Perry, Armando J. Parodi, and Miguel A. Valvano. 1999. “The Activity of a Putative Polyisoprenol-Linked Sugar Translocase (Wzx) Involved in *Escherichia Coli* O Antigen Assembly Is Independent of the Chemical Structure of the O Repeat.” *The Journal of Biological Chemistry* 274 (49): 35129–38. <http://www.jbc.org/login.ezproxy.library.ualberta.ca/content/274/49/35129.long>.
- Fry, B N, V Korolik, J A ten Brinke, M T Pennings, R Zalm, B J Teunis, P J Coloe, and B A van der Zeijst. 1998. “The Lipopolysaccharide Biosynthesis Locus of *Campylobacter Jejuni* 81116.” *Microbiology (Reading, England)* 144 ( Pt 8 (Pt 8): 2049–61.
- Furlong, S E, and M A Valvano. 2012. “Characterization of the Highly Conserved VFMGD Motif in a Bacterial Polyisoprenyl-Phosphate N-Acetylaminosugar-1-Phosphate Transferase.” *Protein Science : A Publication of the Protein Society* 21 (9): 1366–75.
- Garcia-Quintanilla, Fatima, Jeremy A. Iwashkiw, Nancy L. Price, Chad Stratilo, and Mario F. Feldman. 2014. “Production of a Recombinant Vaccine Candidate against *Burkholderia Pseudomallei* Exploiting the Bacterial N-Glycosylation Machinery.” *Front. Microbiol.* <http://journal.frontiersin.org/Journal/10.3389/fmicb.2014.00381/full>.
- Gaynes, Robert, and Jonathan R Edwards. 2005. “Overview of Nosocomial Infections Caused by Gram-Negative Bacilli.” *Clinical Infectious Diseases : An Official Publication of the Infectious Diseases Society of America* 41 (6): 848–54. doi:10.1086/432803.
- Glover, Kerney Jebrell, Eranthie Weerapana, Mark M Chen, and Barbara Imperiali. 2006. “Direct Biochemical Evidence for the Utilization of UDP-Bacillosamine by PglC, an Essential Glycosyl-1-Phosphate Transferase in the *Campylobacter Jejuni* N-Linked Glycosylation Pathway.”

- Biochemistry* 45 (16). American Chemical Society: 5343–50. doi:10.1021/bi0602056.
- Gordon, N C, and D W Wareham. 2010. “Multidrug-Resistant *Acinetobacter Baumannii*: Mechanisms of Virulence and Resistance.” *International Journal of Antimicrobial Agents* 35 (3): 219–26.
- Gosselin, S, M Alhussaini, and MB Streiff. 1994. “A Continuous Spectrophotometric Assay for Glycosyltransferases.” *Analytical ...* 220 (2): 92–97.  
<http://www.sciencedirect.com/science/article/pii/S0003269784713030>.
- Guerry, Patricia, and Christine M Szymanski. 2008. “*Campylobacter* Sugars Sticking out.” *Trends in Microbiology* 16 (9): 428–35. doi:10.1016/j.tim.2008.07.002.
- Hammes, W P, and F C Neuhaus. 1974. “On the Specificity of Phospho-N-Acetylmuramyl-Pentapeptide Translocase. The Peptide Subunit of Uridine Diphosphate-N-Acetylmuramyl-Pentapeptide.” *The Journal of Biological Chemistry* 249 (10): 3140–50.  
<http://www.ncbi.nlm.nih.gov/pubmed/4208473>.
- Hartley, Meredith D, Michael J Morrison, Finn Erik Aas, Bente Børud, Michael Koomey, and Barbara Imperiali. 2011. “Biochemical Characterization of the O-Linked Glycosylation Pathway in *Neisseria Gonorrhoeae* Responsible for Biosynthesis of Protein Glycans Containing N,N'-Diacetylbacillosamine.” *Biochemistry* 50 (22). American Chemical Society: 4936–48. doi:10.1021/bi2003372.
- Hartley, Meredith D, Philipp E Schneggenburger, and Barbara Imperiali. 2013. “Lipid Bilayer Nanodisc Platform for Investigating Polyprenol-Dependent Enzyme Interactions and Activities.” *Proceedings of the National Academy of Sciences of the United States of America* 110 (52): 20863–70. doi:10.1073/pnas.1320852110.
- Hendley, J O, K R Powell, N L Salomonsky, and R R Rodewald. 1981. “Electron Microscopy of the Gonococcal Capsule.” *The Journal of Infectious Diseases* 143 (6): 796–802.  
<http://www.ncbi.nlm.nih.gov/pubmed/6166692>.
- Heydanek, M G, W G Struve, and F C Neuhaus. 1969. “On the Initial Stage in Peptidoglycan Synthesis. 3. Kinetics and Uncoupling of Phospho-N-Acetylmuramyl-Pentapeptide Translocase (uridine 5'-Phosphate).” *Biochemistry* 8 (3): 1214–21.  
<http://www.ncbi.nlm.nih.gov/pubmed/5781013>.
- Holst Sørensen, Martine C, Lieke B van Alphen, Christopher Fodor, Shauna M Crowley, Bjarke Bak Christensen, Christine M Szymanski, and Lone Brøndsted. 2012. “Phase Variable Expression of Capsular Polysaccharide Modifications Allows *Campylobacter Jejuni* to Avoid Bacteriophage Infection in Chickens.” *Frontiers in Cellular and Infection Microbiology* 2 (January): 11. doi:10.3389/fcimb.2012.00011.
- Hug, Isabelle, and Mario F Feldman. 2011. “Analogies and Homologies in Lipopolysaccharide and Glycoprotein Biosynthesis in Bacteria.” *Glycobiology* 21 (2): 138–51. doi:10.1093/glycob/cwq148.

- Hyland, Sheryl A, and Matt S Anderson. 2003. "A High-Throughput Solid-Phase Extraction Assay Capable of Measuring Diverse Polyprenyl Phosphate: Sugar-1-Phosphate Transferases as Exemplified by the WecA, MraY, and MurG Proteins." *Analytical Biochemistry* 317 (2): 156–65. <http://www.ncbi.nlm.nih.gov/pubmed/12758253>.
- Ielmini, Maria V, and Mario F Feldman. 2011. "Desulfovibrio Desulfuricans PglB Homolog Possesses Oligosaccharyltransferase Activity with Relaxed Glycan Specificity and Distinct Protein Acceptor Sequence Requirements." *Glycobiology* 21 (6): 734–42. doi:10.1093/glycob/cwq192.
- Imperi, Francesco, Luísa C S Antunes, Jochen Blom, Laura Villa, Michele Iacono, Paolo Visca, and Alessandra Carattoli. 2011. "The Genomics of Acinetobacter Baumannii: Insights into Genome Plasticity, Antimicrobial Resistance and Pathogenicity." *IUBMB Life* 63 (12): 1068–74. doi:10.1002/iub.531.
- Iwashkiw, J A, A Seper, B S Weber, N E Scott, E Vinogradov, C Stratilo, B Reiz, et al. 2012. "Identification of a General O-Linked Protein Glycosylation System in Acinetobacter Baumannii and Its Role in Virulence and Biofilm Formation." *PLoS Pathogens* 8 (6): e1002758.
- Iwashkiw, Jeremy A, Nicolas F Voza, Rachel L Kinsella, and Mario F Feldman. 2013. "Pour Some Sugar on It: The Expanding World of Bacterial Protein O-Linked Glycosylation." *Molecular Microbiology* 89 (1): 14–28. doi:10.1111/mmi.12265.
- Joly, A, and P A Edwards. 1993. "Effect of Site-Directed Mutagenesis of Conserved Aspartate and Arginine Residues upon Farnesyl Diphosphate Synthase Activity." *The Journal of Biological Chemistry* 268 (36): 26983–89. <http://www.ncbi.nlm.nih.gov/pubmed/8262934>.
- Kaminski, Lina, Mehtap Abu-Qarn, Ziqiang Guan, Shai Naparstek, Valeria V Ventura, Christian R H Raetz, Paul G Hitchen, Anne Dell, and Jerry Eichler. 2010. "AglJ Adds the First Sugar of the N-Linked Pentasaccharide Decorating the Haloferax Volcanii S-Layer Glycoprotein." *Journal of Bacteriology* 192 (21): 5572–79. doi:10.1128/JB.00705-10.
- Karlyshev, Andrey V, Olivia L Champion, Carol Churcher, Jean-Robert Brisson, Harold C Jarrell, Michel Gilbert, Denis Brochu, et al. 2005. "Analysis of Campylobacter Jejuni Capsular Loci Reveals Multiple Mechanisms for the Generation of Structural Diversity and the Ability to Form Complex Heptoses." *Molecular Microbiology* 55 (1): 90–103. doi:10.1111/j.1365-2958.2004.04374.x.
- Karlyshev, Andrey V., Dennis Linton, Norman A. Gregson, Albert J. Lastovica, and Brendan W. Wren. 2002. "Genetic and Biochemical Evidence of a Campylobacter Jejuni Capsular Polysaccharide That Accounts for Penner Serotype Specificity." *Molecular Microbiology* 35 (3): 529–41. doi:10.1046/j.1365-2958.2000.01717.x.
- Karplus, Kevin. 2009. "SAM-T08, HMM-Based Protein Structure Prediction." *Nucleic Acids Research* 37 (Web Server issue): W492–97. doi:10.1093/nar/gkp403.
- Kempf, Marie, and Jean-Marc Rolain. 2012. "Emergence of Resistance to Carbapenems in

- Acinetobacter Baumannii in Europe: Clinical Impact and Therapeutic Options.” *International Journal of Antimicrobial Agents* 39 (2): 105–14. doi:10.1016/j.ijantimicag.2011.10.004.
- Kenyon, Johanna J, and Ruth M Hall. 2013. “Variation in the Complex Carbohydrate Biosynthesis Loci of Acinetobacter Baumannii Genomes.” Edited by Valerie de Crécy-Lagard. *PloS One* 8 (4). Public Library of Science: e62160. doi:10.1371/journal.pone.0062160.
- Knirel, IuA, and NK Kochetkov. 1994. “Structure of Lipopolysaccharides from Gram-Negative Bacteria. III. Structure of O-Specific Polysaccharides.” *Biokhimiia* 59(12): 1784–1851.
- Krinos, C M, M J Coyne, K G Weinacht, A O Tzianabos, D L Kasper, and L E Comstock. 2001. “Extensive Surface Diversity of a Commensal Microorganism by Multiple DNA Inversions.” *Nature* 414 (6863): 555–58. doi:10.1038/35107092.
- Larkin, Angelyn, and Barbara Imperiali. 2009. “Biosynthesis of UDP-GlcNAc(3NAc)A by WbpB, WbpE, and WbpD: Enzymes in the Wbp Pathway Responsible for O-Antigen Assembly in Pseudomonas Aeruginosa PAO1.” *Biochemistry* 48 (23): 5446–55. doi:10.1021/bi900186u.
- Lees-Miller, Robert G, Jeremy A Iwashkiw, Nichollas E Scott, Andrea Seper, Evgeny Vinogradov, Stefan Schild, and Mario F Feldman. 2013. “A Common Pathway for O-Linked Protein-Glycosylation and Synthesis of Capsule in Acinetobacter Baumannii.” *Molecular Microbiology* 89 (5): 816–30. doi:10.1111/mmi.12300.
- Lehrer, Jason, Karen A Vigeant, Laura D Tatar, and Miguel a Valvano. 2007. “Functional Characterization and Membrane Topology of Escherichia Coli WecA, a Sugar-Phosphate Transferase Initiating the Biosynthesis of Enterobacterial Common Antigen and O-Antigen Lipopolysaccharide.” *Journal of Bacteriology* 189 (7): 2618–28. doi:10.1128/JB.01905-06.
- Lewis, Amanda L, Nolan Desa, Elizabeth E Hansen, Yuriy A Knirel, Jeffrey I Gordon, Pascal Gagneux, Victor Nizet, and Ajit Varki. 2009. “Innovations in Host and Microbial Sialic Acid Biosynthesis Revealed by Phylogenomic Prediction of Nonulosonic Acid Structure.” *Proceedings of the National Academy of Sciences of the United States of America* 106 (32): 13552–57. doi:10.1073/pnas.0902431106.
- Linton, D, N Dorrell, P G Hitchen, S Amber, A V Karlyshev, H R Morris, A Dell, M A Valvano, M Aebi, and B W Wren. 2005. “Functional Analysis of the Campylobacter Jejuni N-Linked Protein Glycosylation Pathway.” *Molecular Microbiology* 55 (6): 1695–1703.
- Luke, Nicole R, Shauna L Sauberan, Thomas A Russo, Janet M Beanan, Ruth Olson, Thomas W Loehfelm, Andrew D Cox, Frank St. Michael, Evgeny V Vinogradov, and Anthony A Campagnari. 2010. “Identification and Characterization of a Glycosyltransferase Involved in Acinetobacter Baumannii Lipopolysaccharide Core Biosynthesis.” *Infection and Immunity* 78 (5): 2017–23.
- Marolda, C L, J Welsh, L Dafoe, and M A Valvano. 1990. “Genetic Analysis of the O7-Polysaccharide Biosynthesis Region from the Escherichia Coli O7:K1 Strain VW187.” *J. Bacteriol.* 172 (7): 3590–99. <http://jb.asm.org.login.ezproxy.library.ualberta.ca/content/172/7/3590.abstract?>

ijkey=dce27026ab9c1cb6716b607a7105b0fab35b32ff&keytype2=tf\_ipsecsha.

- Meadow, P M, J S Anderson, and J L Strominger. 1964. "Enzymatic Polymerization of UDP-acetylmuramyl-L-ala-D-glu-L-lys-D-ala-D-Ala and UDP-Acetylglucosamine by a Particulate Enzyme from *Staphylococcus Aureus* and Its Inhibition by Antibiotics." *Biochemical and Biophysical Research Communications* 14 (January): 382–87.  
<http://www.ncbi.nlm.nih.gov/pubmed/5836529>.
- Merino, Susana, Natalia Jimenez, Raquel Molero, Lamiaa Bouamama, M Regue, J M Tomas, Miguel Regué, and Juan M Tomás. 2011. "A UDP-HexNAc:polyprenol-P GalNAc-1-P Transferase (WecP) Representing a New Subgroup of the Enzyme Family." *Journal of Bacteriology* 193 (8): 1943–52. doi:10.1128/JB.01441-10.
- Miller, Wayne L, Cory Q Wenzel, Craig Daniels, Suzon Larocque, Jean-Robert Brisson, and Joseph S Lam. 2004. "Biochemical Characterization of WbpA, a UDP-N-Acetyl-D-Glucosamine 6-Dehydrogenase Involved in O-Antigen Biosynthesis in *Pseudomonas Aeruginosa* PAO1." *The Journal of Biological Chemistry* 279 (36): 37551–58. doi:10.1074/jbc.M404749200.
- Moran, A. P., and J. L. Penner. 1999. "Serotyping of *Campylobacter Jejuni* Based on Heat Stable Antigens: Relevance, Molecular Basis and Implications in Pathogenesis." *Journal of Applied Microbiology* 86 (3): 361–77. doi:10.1046/j.1365-2672.1999.00713.x.
- Morrison, Michael J, and Barbara Imperiali. 2013. "Biosynthesis of UDP-N,N'-Diacetylbaucillosamine in *Acinetobacter Baumannii*: Biochemical Characterization and Correlation to Existing Pathways." *Archives of Biochemistry and Biophysics* 536 (1): 72–80. doi:10.1016/j.abb.2013.05.011.
- . 2014. "The Renaissance of Bacillosamine and Its Derivatives: Pathway Characterization and Implications in Pathogenicity." *Biochemistry* 53 (4): 624–38. doi:10.1021/bi401546r.
- Mortensen, Brittany L, and Eric P Skaar. 2012. "Host-Microbe Interactions That Shape the Pathogenesis of *Acinetobacter Baumannii* Infection." *Cellular Microbiology* 14 (9): 1336–44. doi:10.1111/j.1462-5822.2012.01817.x.
- Murray, C, P T Scott, K A Moran, and D W Craft. 2008. "US Army Experience with *Acinetobacter* in Operation Iraqi Freedom." In , edited by E Bergogne-Bérézin, 197. *Acinetobacter Biology and Pathogenesis*. Springer Science.
- Nothaft, H, and C M Szymanski. 2010. "Protein Glycosylation in Bacteria: Sweeter than Ever." *Nature reviews.Microbiology* 8 (11): 765–78.
- Patel, Kinnari B, Sarah E Furlong, and Miguel A Valvano. 2010. "Functional Analysis of the C-Terminal Domain of the WbaP Protein That Mediates Initiation of O Antigen Synthesis in *Salmonella Enterica*." *Glycobiology* 20 (11): 1389–1401. doi:10.1093/glycob/cwq104.
- Patel, Kinnari B, Evelyn Toh, Ximena B Fernandez, Anna Hanuszkiewicz, Gail G Hardy, Yves V Brun, Mark a Bernards, and Miguel A Valvano. 2012. "Functional Characterization of UDP-Glucose:undecaprenyl-Phosphate Glucose-1-Phosphate Transferases of *Escherichia Coli* and

- Caulobacter Crescentus.” *Journal of Bacteriology* 194 (10): 2646–57. doi:10.1128/JB.06052-11.
- Peleg, A Y, H Seifert, and D L Paterson. 2008. “Acinetobacter Baumannii: Emergence of a Successful Pathogen.” *Clinical Microbiology Reviews* 21 (3): 538–82.
- Pelosi, Ludovic, Manel Boumedienne, Nehmé Saksouk, Johannes Geiselmann, and Roberto A Geremia. 2005. “The Glucosyl-1-Phosphate Transferase WchA (Cap8E) Primes the Capsular Polysaccharide Repeat Unit Biosynthesis of Streptococcus Pneumoniae Serotype 8.” *Biochemical and Biophysical Research Communications* 327 (3): 857–65. doi:10.1016/j.bbrc.2004.12.082.
- Power, Peter M, Kate L Seib, and Michael P Jennings. 2006. “Pilin Glycosylation in Neisseria Meningitidis Occurs by a Similar Pathway to Wzy-Dependent O-Antigen Biosynthesis in Escherichia Coli.” *Biochemical and Biophysical Research Communications* 347 (4): 904–8. doi:10.1016/j.bbrc.2006.06.182.
- Price, Neil P, and Frank A Momany. 2005. “Modeling Bacterial UDP-HexNAc: Polyprenol-P HexNAc-1-P Transferases.” *Glycobiology* 15 (9): 29R – 42R. doi:10.1093/glycob/cwi065.
- Raymond, Jon B, Seabrata Mahapatra, Dean C Crick, and Martin S Pavelka. 2005. “Identification of the namH Gene, Encoding the Hydroxylase Responsible for the N-Glycolylation of the Mycobacterial Peptidoglycan.” *The Journal of Biological Chemistry* 280 (1): 326–33. doi:10.1074/jbc.M411006200.
- Rocchetta, H L, L L Burrows, and J S Lam. 1999. “Genetics of O-Antigen Biosynthesis in Pseudomonas Aeruginosa.” *Microbiology and Molecular Biology Reviews* 63 (3): 523–53.
- Rocchetta, H L, L L Burrows, J C Pacan, and J S Lam. 1998. “Three Rhamnosyltransferases Responsible for Assembly of the A-Band D-Rhamnan Polysaccharide in Pseudomonas Aeruginosa: A Fourth Transferase, WbpL, Is Required for the Initiation of Both A-Band and B-Band Lipopolysaccharide Synthesis.” *Molecular Microbiology* 28 (6): 1103–19. <http://www.ncbi.nlm.nih.gov/pubmed/9680202>.
- Rush, Jeffrey S, Cristina Alaimo, Riccardo Robbiani, Michael Wacker, and Charles J Waechter. 2010. “A Novel Epimerase That Converts GlcNAc-P-P-Undecaprenol to GalNAc-P-P-Undecaprenol in Escherichia Coli O157.” *The Journal of Biological Chemistry* 285 (3): 1671–80. doi:10.1074/jbc.M109.061630.
- Russo, T A, N R Luke, J M Beanan, R Olson, S L Sauberan, U MacDonald, L W Schultz, T C Umland, and A A Campagnari. 2010. “The K1 Capsular Polysaccharide of Acinetobacter Baumannii Strain 307-0294 Is a Major Virulence Factor.” *Infection and Immunity* 78 (9): 3993–4000.
- Saldías, M Soledad, Kinnari Patel, Cristina L Marolda, Mauricio Bittner, Inés Contreras, and Miguel A Valvano. 2008. “Distinct Functional Domains of the Salmonella Enterica WbaP Transferase That Is Involved in the Initiation Reaction for Synthesis of the O Antigen Subunit.” *Microbiology (Reading, England)* 154 (Pt 2): 440–53. doi:10.1099/mic.0.2007/013136-0.
- Schmidt, G, H Mayer, and P H Mäkelä. 1976. “Presence of Rfe Genes in Escherichia Coli: Their

Participation in Biosynthesis of O Antigen and Enterobacterial Common Antigen.” *Journal of Bacteriology* 127 (2): 755–62. <http://www.pubmedcentral.nih.gov/articlerender.fcgi?artid=232981&tool=pmcentrez&rendertype=abstract>.

- Schoenhofen, Ian C, Evgeny Vinogradov, Dennis M Whitfield, Jean-Robert Brisson, and Susan M Logan. 2009. “The CMP-Legionaminic Acid Pathway in *Campylobacter*: Biosynthesis Involving Novel GDP-Linked Precursors.” *Glycobiology* 19 (7): 715–25. doi:10.1093/glycob/cwp039.
- Scott, Nichollas E, Rachel L Kinsella, Alistair V G Edwards, Martin R Larsen, Sucharita Dutta, Julian Saba, Leonard J Foster, and Mario F Feldman. 2014. “Diversity within the O-Linked Protein Glycosylation Systems of *Acinetobacter* Species.” *Molecular & Cellular Proteomics : MCP* 13 (9): 2354–70. doi:10.1074/mcp.M114.038315.
- Settem, Rajendra P, Kiyonobu Honma, Graham P Stafford, and Ashu Sharma. 2013. “Protein-Linked Glycans in Periodontal Bacteria: Prevalence and Role at the Immune Interface.” *Frontiers in Microbiology* 4 (January). Frontiers: 310. doi:10.3389/fmicb.2013.00310.
- Skurnik, M, R Venho, J A Bengoechea, and I Moriyón. 1999. “The Lipopolysaccharide Outer Core of *Yersinia Enterocolitica* Serotype O:3 Is Required for Virulence and Plays a Role in Outer Membrane Integrity.” *Molecular Microbiology* 31 (5): 1443–62. <http://www.ncbi.nlm.nih.gov/pubmed/10200964>.
- Smith, M. G., T. A. Gianoulis, S. Pukatzki, J. J. Mekalanos, L. N. Ornston, M. Gerstein, and M. Snyder. 2007. “New Insights into *Acinetobacter Baumannii* Pathogenesis Revealed by High-Density Pyrosequencing and Transposon Mutagenesis.” *Genes & Development* 21 (5): 601–14. doi:10.1101/gad.1510307.
- Spyropoulos, Ioannis C, Theodore D Liakopoulos, Pantelis G Bagos, and Stavros J Hamodrakas. 2004. “TMRPres2D: High Quality Visual Representation of Transmembrane Protein Models.” *Bioinformatics (Oxford, England)* 20 (17): 3258–60. doi:10.1093/bioinformatics/bth358.
- Stachyra, T., C. Dini, P. Ferrari, A. Bouhss, J. van Heijenoort, D. Mengin-Lecreulx, D. Blanot, J. Biton, and D. Le Beller. 2004. “Fluorescence Detection-Based Functional Assay for High-Throughput Screening for *MraY*.” *Antimicrobial Agents and Chemotherapy* 48 (3): 897–902. doi:10.1128/AAC.48.3.897-902.2004.
- Szymanski, Christine M, and Brendan W Wren. 2005. “Protein Glycosylation in Bacterial Mucosal Pathogens.” *Nature Reviews. Microbiology* 3 (3). Nature Publishing Group: 225–37. doi:10.1038/nrmicro1100.
- Toh, Evelyn, Harry D Kurtz, and Yves V Brun. 2008. “Characterization of the *Caulobacter Crescentus* Holdfast Polysaccharide Biosynthesis Pathway Reveals Significant Redundancy in the Initiating Glycosyltransferase and Polymerase Steps.” *Journal of Bacteriology* 190 (21): 7219–31. doi:10.1128/JB.01003-08.
- Tsai, Chao-Ming, and Carl E. Frasch. 1982. “A Sensitive Silver Stain for Detecting



Lipopolysaccharides in Polyacrylamide Gels.” *Analytical Biochemistry* 119 (1): 115–19.  
doi:10.1016/0003-2697(82)90673-X.

- Umland, Timothy C, L Wayne Schultz, Ulrike MacDonald, Janet M Beanan, Ruth Olson, and Thomas A Russo. 2012. “In Vivo-Validated Essential Genes Identified in *Acinetobacter Baumannii* by Using Human Ascites Overlap Poorly with Essential Genes Detected on Laboratory Media.” *mBio* 3 (4): e00113–12 – . doi:10.1128/mBio.00113-12.
- Valvano, Miguel A. 2003. “Export of O-Specific Lipopolysaccharide.” *Frontiers in Bioscience: A Journal and Virtual Library* 8 (12): 452–71. <http://europepmc.org/abstract/MED/12700099>.
- Valvano, Miguel A. 2011. “Common Themes in Glycoconjugate Assembly Using the Biogenesis of O-Antigen Lipopolysaccharide as a Model System.” *Biochemistry. Biokhimiā* 76 (7): 729–35.  
doi:10.1134/S0006297911070029.
- Van Heijenoort, J. 2001. “Formation of the Glycan Chains in the Synthesis of Bacterial Peptidoglycan.” *Glycobiology* 11 (3): 25R – 36R. <http://www.ncbi.nlm.nih.gov/pubmed/11320055>.
- Wacker, M, D Linton, P G Hitchen, M Nita-Lazar, S M Haslam, S J North, M Panico, et al. 2002. “N-Linked Glycosylation in *Campylobacter Jejuni* and Its Functional Transfer into *E. Coli*.” *Science (New York, N.Y.)* 298 (5599): 1790–93.
- Wang, L, D Liu, and P R Reeves. 1996. “C-Terminal Half of *Salmonella Enterica* WbaP (RfbP) Is the Galactosyl-1-Phosphate Transferase Domain Catalyzing the First Step of O-Antigen Synthesis.” *Journal of Bacteriology* 178 (9): 2598–2604.  
<http://www.pubmedcentral.nih.gov/articlerender.fcgi?artid=177985&tool=pmcentrez&rendertype=abstract>.
- Wenzel, C Q, C Daniels, R A Keates, D Brewer, and J S Lam. 2005. “Evidence That WbpD Is an N-Acetyltransferase Belonging to the Hexapeptide Acyltransferase Superfamily and an Important Protein for O-Antigen Biosynthesis in *Pseudomonas Aeruginosa* PAO1.” *Molecular Microbiology* 57 (5): 1288–1303.
- Westman, Erin L, David J McNally, Martin Rejzek, Wayne L Miller, Vellupillai Sri Kannathan, Andrew Preston, Duncan J Maskell, Robert A Field, Jean-Robert Brisson, and Joseph S Lam. 2007. “Identification and Biochemical Characterization of Two Novel UDP-2,3-Diacetamido-2,3-Dideoxy-Alpha-D-Glucuronic Acid 2-Epimerases from Respiratory Pathogens.” *The Biochemical Journal* 405 (1): 123–30. doi:10.1042/BJ20070017.
- Westman, Erin L, Andrew Preston, Robert A Field, and Joseph S Lam. 2008. “Biosynthesis of a Rare Di-N-Acetylated Sugar in the Lipopolysaccharides of Both *Pseudomonas Aeruginosa* and *Bordetella Pertussis* Occurs via an Identical Scheme despite Different Gene Clusters.” *Journal of Bacteriology* 190 (18): 6060–69.
- Whitfield, Chris. 2006. “Biosynthesis and Assembly of Capsular Polysaccharides in *Escherichia Coli*.” *Annual Review of Biochemistry* 75 (January). Annual Reviews: 39–68.

doi:10.1146/annurev.biochem.75.103004.142545.