

*This document has been  
digitized by the Oil Sands  
Research and Information  
Network, University of  
Alberta with permission of  
Alberta Environment.*

EVALUATION, ANALYSIS, AND ASSESSMENT OF  
SNOWPACK AND PRECIPITATION DATA  
FROM A MONITORING NETWORK  
IN THE AOSERP STUDY AREA

by

C.S. Davis

P. Fellin

D. Stevens

S. Todd

K. Heidorn

Concord Scientific Corporation

for

RESEARCH MANAGEMENT DIVISION  
Alberta Environment

RMD Report 86/36  
1985

EXECUTIVE SUMMARY

Although precipitation and snowpack samples have been collected in a monitoring network in the oil sands of Alberta since 1976 and the monitoring data collected have been the subject of several reports that have dealt with various aspects of the data and network operations, the overall assessment of the network and the data have not been systematically evaluated. Concord Scientific Corporation was commissioned to conduct such an evaluation through:

1. Transformation of the existing free format data into a consistent format;
2. Evaluation of the data by application of screening procedures and assessment of field and laboratory procedures of the network's operation;
3. Statistical analysis of the quality assurance and quality control data generated throughout the network's operation;
4. Statistical analysis of the monitoring data to determine spatial and temporal trends and interparameter relationships; and
5. Preliminary assessment of the likely impact of future emissions on precipitation chemistry in the study area.

The study yielded the following results:

Database Conversion

The data have been converted into a format consistent with the NAQUADAT database. The raw data have been transformed into a fixed format file, screened, and the resultant categories of data placed in separate files. The attributes of the screened data have been recorded in a flag file that has a format similar to that in the raw and screened arrays. Considerable merging of data was necessary since there were often replicate records containing different types of information about the same sample. The multiplicity of files and their inconsistent formats presented significant problems for the file conversion process,

the most severe of these being the lack of complete analytical data on samples, the lack of complete information or incorrect sample dates, and the lack of data on volume of rain sample collected and snow depth. The lack of data on precipitation amounts and the variable collection efficiencies limited the evaluation of deposition estimates. Other problems required extensive editing of the raw data and the customizing of software to allow conversion of each file.

#### Screening of Data

The screening techniques applied to the data identified outliers (values greater than two standard deviations from the mean) and samples in which selected groups of ionic species had simultaneously high values or in which the anion/cation ratio (A/C) fell outside the prescribed range ( $0.5 < A/C < 1.5$ ). On average, about 3% of data in each year were flagged as outliers excepting 1984, in which 15% of rain data and 8% of snowcore data were flagged, and 1981, in which over 60% of the data were excluded due to low A/C ratios or simultaneous occurrence of high ionic concentrations. The incidence of simultaneously high values for certain parameters was low (< 3%) except for 1981 snow data, and the coincidence of high  $\text{Ca}^{2+}$  and  $\text{Mg}^{2+}$ , typical of soil contamination, was low. Missing data for ionic species precluded the application of A/C screening procedures in several cases, specifically the 1981 snow data.

#### Sample Collection

The collection efficiencies of rain samplers were determined, but the daytime-only sample collection schedule rendered the collection efficiencies invalid in cases where rainfall occurred at night. Only 30% of the daily sampler efficiencies were greater than 75%. The various efficiencies observed reflect the incomplete collection (low efficiencies) as well as other problems associated with poor sampler or operator performance (high and variable efficiencies). The lack of sampler evaluation studies (to characterize sampler collection efficiencies) and more detailed time-resolved standard rain gauge data preclude resolution of the causes for the poor collection efficiencies.

In view of the low sample collection efficiencies, the reliability of the rain data in describing wet deposition is low.

In collecting snow samples, the occurrence of thaw periods prior to or during sampling has the potential for leaching pollutants from the snow deposit, thereby causing inaccuracy in estimates of the deposition process. In 1984 the likelihood of such an effect was very great, while in 1976, 1981, and 1983 it was low. In 1976, temperatures were consistently low, so leaching effects were not at all likely.

The lack of snow depth data in 1981, 1983, and 1984, the absence of historical snowfall data, and the lack of accurate dates on which samples were taken preclude the detailed analysis of snow deposition.

Current techniques and protocols for precipitation sampling clearly lead to unreliable estimates for deposition of all parameters.

#### Quality Assurance/Quality Control

One intensive quality assurance/quality control (QA/QC) programme was conducted in the network's history, and other QA/QC activities were limited to analysis of split and spiked samples. There were some interlaboratory studies, but these were poorly documented and evaluated and routine QA/QC samples were inadequate. The major conclusions derived from the available data are as follows:

1. In the 1983 QA/QC programme, the only one in which blank data were routinely available, the levels of  $\text{NH}_4^+$ ,  $\text{Ca}^{2+}$ , and  $\text{Mg}^{2+}$  approached or exceeded acceptable levels relative to those in samples (> 10%).
2. Data for co-located samplers (1983 study) were generally good for  $\text{SO}_4^{2-}$  - S,  $\text{NO}_3^-$ , conductivity, pH,  $\text{Ca}^{2+}$ , and  $\text{Mg}^{2+}$ , but lower for  $\text{NH}_4^+$ ,  $\text{Na}^+$ , and  $\text{Cl}^-$ , with some bias for  $\text{Cl}^-$ . Unfortunately, the 1983 study did not include the detailed measurements of sampler collection efficiencies.
3. Statistical analyses of replicate or duplicate data generated in other years were also conducted. Of all

species,  $\text{Na}^+$  had the highest variability, while other parameters analysed in the same sample aliquot showed less variability.

4. Information attesting to the operation of laboratory QA/QC practices was unavailable, which indicates that timely data validation was not a feature of the network's operation.

#### Laboratory Operations

There was lack of information required to evaluate many aspects of laboratory performance. The sample reception and handling procedures within the laboratories were undocumented, save for the 1984 period during which the Chemex laboratory analysed samples. While the analytical methods used were acceptable insofar as their sensitivity, reliability, and suitability were concerned, there was little if any information on laboratory QA/QC programs. The QA/QC samples that were consistently generated were restricted to analyses of spiked samples and within-run duplicates. Suitable blanks were generated in 1983 and 1984, and reference was made to round-robin studies in 1976, 1977, 1981, and 1984, but data from these studies were not well documented.

Sample handling protocols for snowcore analyses varied throughout the period, but procedures improved significantly in 1984. Sample storage and documentation of laboratory protocols were aspects of the operation that needed and did show improvement in 1984.

#### Field Operations

The evaluation of field operations for rain and snowcore sampling constituted a major component of the work program. The evaluation considered siting criteria, site suitability and representativeness, the logistics of sample collection and transport, and the implications of these activities for data quality.

Stated siting criteria purportedly were based in part on the Ontario APIOS siting criteria, which is concerned with background rather than point-source related sampling. The AOSERP sites are well distributed around the major point sources. Evaluation of sites was in

part limited by the incompleteness of site documentation (specific siting information missing, incomplete, or outdated, or inadequate site drawings). Six sites with unacceptable surroundings have been identified.

#### Statistical Analysis of Monitoring Data

Attempts were made to elicit temporal and spatial patterns in the data and also to characterize interparameter relationships.

Annual frequency distributions for network-wide concentrations of selected parameters in rain and snow were determined and illustrated in box plots indicating concentrations corresponding to various percentiles. Given the fact that there were major differences in the data from year to year (numbers of stations, sampling and analytical methods), detailed analysis of the data for trends is not warranted. There was some indication that the annual means for the concentrations of sulphate and ammonium and for conductivity increased with time, but it should be noted that the data each year overlapped considerably and definite trends in the data cannot be established. In the cases of sodium, potassium, and conductivity, there was a general increasing pattern in the percentiles between 1976 and 1979, but thereafter the values for conductivity were lower and, in the cases of sodium and potassium, much less scattered. Calcium concentrations showed great variability.

In general, annual and monthly mean concentrations for selected parameters at selected stations reflected the network-wide patterns but again, the overlap in the data from year to year precludes firm conclusions about trends.

Maps showing isopleths of concentration values for selected parameters were prepared, but in view of the very large degree of overlap (the standard deviations would include two or more adjacent isopleth lines), the plots have little significance.

The determination of interparameter relationships was based on the calculation of correlation coefficients among 22 parameters. The strongest correlations were among the major ions and were consistent with precipitation chemistry. A distance parameter (between the station and

the mid-point between the Syncrude and Suncor plants) showed relatively lower correlations with ions or metals, but some correlations were significant (at the 99% level of confidence) with V, Al,  $\text{SO}_4^{2-}$ ,  $\text{Ca}^{2+}$ ,  $\text{PO}_4^{3-}$ , and  $\text{Cl}^-$ . In the case of snow data, the correlations among ions were stronger than similar correlations in the rain data.

Factor analyses of the rain and snow data (separately) were carried out based on data subsets [records with at least 10 (rain) or 13 (snow) parameters]. In the case of snow, there was a single dominating factor, which indicated point-source influence. The rain data also showed a similar factor, but its dominance was not as great. The rain data pointed to five other factors of decreasing significance, none of which could be readily explained. There was some indication of another point source-related factor and a factor indicating background (soil?) sources. The surprising feature of the factor analysis of the snow data was the behaviour of  $\text{NO}_3^-$  and to lesser extents Fe and Ni, none of which had high loadings with the distance-related factor.

### Episodic Rain Events

Episodic rain events were identified based on the occurrence of high concentrations (in the upper 15th percentile of their distributions) of selected parameters at four or more stations. Representative periods in each year were selected and the synoptic features for those days were analysed.

Most episodes resulted from local convective activity, the early stages of cyclone formation, or stationary or slow-moving cyclones. Such features made construction of detailed back-trajectories difficult. The patterns on ionic concentrations implicate the local sources, but their resolution (relative contribution) was not possible.

A review of climatological storm tracks for the area indicated that passage along southeast to east paths is most frequent. Urban centres to the south and the thermal generating and gas processing plants along the eastern foothills and farther east are not likely to influence AOSERP study area precipitation. The northernmost Alberta-British Columbia border area would therefore be the most important upwind source

region, but there was no evidence for long-range transport contributing to episodes. There are gas processing plants in that region, but their emissions are small relative to the local AOSERP study area sources.

### Recommendations

The following recommendations are based on the assessment of the data collection network and procedures, and the analysis of the data.

1. That the network objectives be clearly restated and documented. The development of the objectives should include the consideration of other environmental monitoring activities in the area, the limitations imposed by not maintaining an all-year sampling program, and available resources.
2. That a comprehensive network documentation package be developed to specify protocols for all network operations. The protocols need to be uniform and universally applied to ensure consistent, reliable, and uniform data. The documentation should include:
  - a. Siting and site documentation,
  - b. Instrumentation specifications,
  - c. Field operations and protocols;
  - d. Laboratory protocols,
  - e. Sample handling and processing,
  - f. A comprehensive quality assurance plan, and
  - g. Data capture, validation, retrieval, and reporting.
3. That only those sites meeting acceptable criteria be retained in the network. The site documentation package should be complete and kept updated.
4. That the automated solar power/battery operated samplers such as the MIC or Aerochemetrics samplers be acquired and deployed in the network since in the case of rainfall sampling, the



currently used manual system with daytime only collection will be subject to inconsistent and uncertain data quality. Sites at which mains power is available or can be installed easily and inexpensively should use that power source.

5. That routine QA/QC protocols be developed for assessing precision of measurement. The results of these procedures should be analysed frequently and reported. The laboratory protocols implemented in 1984 were quite adequate and should be continued. However, there should be regular participation and evaluation of interlaboratory comparison studies. Participation in these studies should be mandatory, and results should be used to qualify laboratories for analysis of AOSERP network samples. Laboratory procedures should be clearly documented and should include QA/QC test protocols. Results of the QA/QC should be reported routinely to network management.
6. That a quality assurance plan be developed to address all aspects of network operation, including the level of documentation, systematic instrumentation checks, sample handling procedure checks, laboratory QA/QC requirements, interlaboratory comparison, reporting requirements, and the number and type of QA samples to be generated by network staff. In addition, provision should be made for external audits of network operations to verify correct implementation procedures. This audit should include a report to network management on deficiencies found and recommendations for rectifying these deficiencies.
7. That the existing method of storing data be immediately abandoned since it is unacceptable. In the short term, data storage should take place in a fixed format file identical or similar to the format provided in this study. It is

recommended that a database management system (DBMS) of the relational type be used as the major tool in a software package that will allow the capture, storage, retrieval, validation, reporting, and statistical analysis of AOSERP precipitation data. It is essential that the DBMS selected and the software package, together with the network field and laboratory operations, allow the data capture process to take place in a timely and efficient manner.

TABLE OF CONTENTS

	Page
LIST OF TABLES .....	xxi
LIST OF FIGURES .....	xxvi
ABSTRACT .....	xxx
ACKNOWLEDGEMENTS .....	xxxi
1. INTRODUCTION .....	1
1.1 Overview of the Network .....	3
1.1.1 Description of the Study Area .....	3
1.1.2 Network Objectives .....	5
1.1.3 Data Availability .....	5
1.1.4 Previous Related Studies .....	5
2. DATA VALIDATION .....	9
2.1 Introduction .....	9
2.2 Procedures for File Conversion and Screening .....	9
2.2.1 Reformatting of Raw Data .....	11
2.2.1.1 Description of Raw Data .....	11
2.2.2 Description of the NAQUADAT Format .....	11
2.2.3 Procedure for Reformatting Data .....	15
2.2.3.1 Extensions to NAQUADAT .....	15
2.2.3.2 Raw Arrays .....	20
2.2.3.3 Screened NAQUADAT .....	27
2.2.3.4 Suspect Data Files .....	27
2.2.3.5 Screened Arrays .....	28
2.3 Data Availability .....	28
2.4 Recommendations for the AOSERP Database .....	29
3. NETWORK QUALITY ASSURANCE/QUALITY CONTROL .....	34
3.1 Evaluation of the AOSERP Precipitation Network .....	37
3.1.1 Specific Network Objectives .....	37
3.1.2 Site Selection Criteria and Evaluation .....	40
3.1.3 Sample and Field Data Collection and Handling .....	47
3.1.3.1 1976 to 1979 .....	47
3.1.3.2 1981, 1982, 1984 .....	50
3.1.3.3 1982 .....	50
3.1.3.4 1984 .....	53
3.1.4 Precipitation Field Quality Assurance/Quality Control .....	60
3.2 Review and Documentation of the AOSERP Snow Surveys .....	68
3.2.1 Survey Objectives and Design Plan .....	68
3.2.2 Sampling Site Selection Criteria Evaluation .....	70
3.2.3 Field Operations .....	73
3.2.3.1 Sample Collection .....	73
3.2.3.2 Sample Handling and Shipping .....	78

continued ...

TABLE OF CONTENTS (CONTINUED)

	Page	
3.2.3.3	Field Data Collection .....	82
3.2.3.4	Quality Assurance for Field Operations .....	82
3.3	Laboratory Sample Analysis and QA/QC .....	86
3.3.1	Laboratory QA/QC .....	86
3.3.1.1	Calibration Procedure and Verification .....	87
3.3.1.2	Recovery Checks .....	88
3.3.1.3	Precision .....	88
3.3.1.4	Accuracy .....	89
3.3.1.5	Blanks .....	89
3.3.2	Laboratory Sample Reception, Preparation and Handling .....	89
3.3.3	Chemical Analysis .....	98
4.	DATA EVALUATION .....	112
4.1	Introduction .....	112
4.2	Discussion of Data Screening Results .....	113
4.2.1	Data Outliers .....	114
4.2.2	High Concentration Samples .....	115
4.3	Quality Assurance Aspects of the Sampling and Analytical Protocols .....	119
4.3.1	Sampler Collection Efficiency .....	122
4.3.2	Winter Thaw Periods .....	130
4.3.3	Blank Samples .....	132
4.3.4	Laboratory Duplicate Data .....	135
4.3.5	Replicate Results .....	137
4.3.6	Co-located Sampling .....	143
4.3.7	Interlaboratory Studies .....	145
5.	DATA ANALYSIS AND INTERPRETATION .....	146
5.1	Introduction .....	146
5.2	Statistics on Rain Data .....	146
5.2.1	Temporal Trends .....	146
5.2.1.1	Frequency Distributions - Box Plots .....	147
5.2.1.2	Trends in Annual and Monthly Means .....	159
5.2.2	Spatial Patterns .....	165
5.3	Statistics on Snow Data .....	172
5.3.1	Temporal Trends.....	172
5.3.2	Spatial Patterns .....	173
5.4	Interrelationships Between Parameters .....	188
5.4.1	Factor Analysis for Rain Data .....	190
5.4.1.1	Correlation Matrices .....	190
5.4.1.2	Factor Analysis - Rain Data .....	190
5.4.2	Factor Analysis for Snow Data .....	192
5.4.2.1	Correlation Matrices .....	192
5.4.2.2	Factor Analysis - Snow Data .....	194
5.5	Episodic Rain Events .....	194

continued ...

TABLE OF CONTENTS (CONTINUED)

	Page	
5.5.1	Synoptic Weather Analysis for Selected Wet Deposition Periods .....	195
5.5.2	Cyclone Climatology of Northeastern Alberta - May to September .....	195
5.6	Source Regions Affecting AOSERP Precipitation .....	197
5.6.1	Local Sources .....	199
5.6.2	Summary .....	199
5.7	Historical and Project Point Source Emissions and Precipitation Quality .....	201
6.	CONCLUSIONS AND RECOMMENDATIONS .....	207
6.1	Database Aspects .....	207
6.2	Data Evaluation .....	208
6.2.1	Screening .....	208
6.2.2	Sample Collection Aspects .....	209
6.2.3	Analysis of Duplicate and Replicate Data.....	209
6.3	Assessment of Laboratory and Field Operations .....	210
6.3.1	Laboratory Operations .....	210
6.3.2	Field Operations .....	211
6.4	Statistical Analysis of Monitoring Data .....	211
6.4.1	Temporal and Spatial Patterns .....	211
6.4.2	Interparameter Relationships .....	212
6.5	Episodic Rain Events .....	213
6.6	Historical and Future Emissions .....	213
6.7	Recommendations .....	214
6.7.1	Network Objectives .....	215
6.7.2	Documentation .....	215
6.7.3	Siting of Stations .....	215
6.7.4	Instrumentation .....	216
6.7.5	Field and Laboratory Operations .....	216
6.7.6	Quality Assurance and Quality Control .....	216
6.7.7	Data Capture, Validation, Retrieval and Reporting .....	217
7.	REFERENCES CITED .....	218
8.	APPENDICES .....	222
8.1	Raw Data File Reference .....	222
8.2	AOSERP Site Diagrams .....	224
8.3	Proposed Site Documentation Package for AOSERP Sites .....	239
8.4	Sample Handling and Sample Integrity .....	264
8.5	Site Selection Criteria - Snow Chemistry Survey .....	265
8.6	Snowcore Site Descriptions .....	267
8.7	Site Documentation for Snowcore Sites .....	272

continued ...

TABLE OF CONTENTS (CONCLUDED)

	Page
8.8	Snowcore Sampling Procedures (1976, 1978, and 1981). 280
8.9	Snowcore Sampling Procedures (1983 and 1984) ..... 281
8.10	Terms of Reference for the Chemical Analysis of Winter Precipitation for the 1984 Survey ..... 283
8.11	Duplicate Results ..... 288
8.12	Replicate Results ..... 296
8.13	Sampler Collection Efficiencies ..... 312
8.14	Co-located Sampling ..... 325
8.15	A Summary of Synoptic Weather Analysis for Selected Wet Deposition Periods ..... 335
8.15.1	31 July to 2 August 1979 ..... 335
8.15.2	17 May 1981 ..... 335
8.15.3	5 July 1981 ..... 336
8.15.4	12 August 1981 ..... 336
8.15.5	1 September 1981 ..... 337
8.15.6	14-17 May 1982 ..... 337
8.15.7	6 August 1982 ..... 338
8.15.8	11 August 1982 ..... 339
8.15.9	1 June 1984 ..... 339
8.15.10	5 June 1984 ..... 340
8.15.11	29 June 1984 ..... 340
8.15.12	4 August 1984 ..... 340
8.15.13	6 August 1984 ..... 341

LIST OF TABLES

	Page
1. Summary of Precipitation Monitoring Data Available from the AOSERP Monitoring Network, 1976 to 1984 .....	6
2. Summary of Snow and Snowcore Monitoring Data Available from the AOSERP Monitoring Network, 1976 to 1984 .....	7
3. Summary of Reports on Data from the AOSERP Precipitation and Snowpack Monitoring Network .....	8
4. NAQUADAT Record Structure .....	12
5. List of Stations .....	16
6. Summary of Arbitrarily Assigned Dates Due to Missing or Incomplete Information .....	19
7. Screenable Parameters .....	22
8. Unscreenable Parameters .....	26
9. AOSERP Precipitation Monitoring Network Operation Summary .....	38
10. Siting Criteria .....	41
11. Summary of Siting Information Available from Site Diagrams .....	45
12. Summary of Siting Information Available from Photographs, Slides, and Site Diagrams .....	46
13. Summary of Sample Handling Procedures .....	51
14. AOSERP Summer Precipitation Sampling Instrumentation .....	56
15. Field QA/QC Procedures - Precipitation .....	61
16. 1983 Field Quality Control Samples .....	63
17. 1983 Rain Project Field Log .....	64
18. Summary of Snow Chemistry Studies Completed .....	69
19. Summary of Snowcore Sample Handling Procedures .....	74
20. Field QA/QC Procedures - Snowpack .....	85
	continued ...

LIST OF TABLES (CONTINUED)

	Page
21. Summary of Laboratory and Network Quality Control Sample Types .....	90
22. Laboratory QA/QC - Precipitation Studies .....	92
23. Laboratory QA/QC - Snowcore Studies .....	93
24. Summary of Laboratory Sample Storage and Handling Procedures for Precipitation Samples .....	95
25. Summary of Laboratory Sample Storage and Handling Procedures for Snowcore Samples .....	97
26. Methods of Analysis for the Summer Precipitation Project, 1976 to 1979 .....	101
27. Methods of Analysis for the Summer Precipitation Project, 1981 to 1982 .....	102
28. Methods of Analysis for the Summer Precipitation Project, 1983 .....	103
29. Methods of Analysis for the Summer Precipitation Project, 1984 .....	104
30. Methods of Analysis for the Snowcore Project, 1976 .....	106
31. Methods of Analysis for the Snowcore Project, 1978 .....	107
32. Methods of Analysis for the Snowcore Project, 1981 .....	108
33. Methods of Analysis for the Snowcore Project, 1981 (QA/QC) .....	109
34. Methods of Analysis for the Snowcore Project, 1983 .....	110
35. Methods of Analysis for the Snowcore Project, 1984 .....	111
36. Outliers - AOSERP Summer Precipitation Study .....	116
37. Outliers - AOSERP Winter Precipitation Study .....	117
38. Summary of Screening Programs for the AOSERP Summer Precipitation Study .....	120
39. Summary of Screening Programs for the AOSERP Winter Precipitation Study .....	121

continued ...



LIST OF TABLES (CONTINUED)

	Page
40. Monthly Efficiencies for Rain Samplers in the AOSERP Summer Precipitation Network .....	125
41. Sample Calculation of Sampler Collection Efficiency .....	128
42. Monthly Efficiencies for Rain Samplers Located at the SANDALTA Station, 1983 .....	129
43. AOSERP Winter Thaw Periods .....	131
44. Blank Data, 1983 .....	133
45. Blank Samples, 1983 .....	134
46. Relative Standard Deviations for Selected Parameters Monitored in AOSERP Summer Precipitation Studies .....	138
47. Relative Standard Deviations for Selected Parameters Monitored in AOSERP Winter Precipitation Studies .....	139
48. Replicate Results for the Summer Precipitation Program..	141
49. Replicate Results for the Winter Precipitation Program..	142
50. Summer Precipitation Study Correlation Coefficients, 1983 .....	144
51. Pearson Correlation Coefficients .....	191
52. Correlation Matrices for Snow Data .....	193
53. List of Episodic Rain Events .....	196
54. Cyclone Frequency and Genesis in a Sector of North- eastern Alberta (55 to 60°N, 110 to 115°W) .....	198
55. Monthly Total Emissions and Volume Weighted Monthly Means for SO <sub>4</sub> <sup>2-</sup> at Individual Stations in the AOSERP Network .....	204
56. Designation of File Numbers for Raw AOSERP Deposition Data .....	223
57. Snowcore Site Descriptions .....	268

continued ...

LIST OF TABLES (CONTINUED)

	Page
58. Laboratory Duplicate Data - The AOSERP Summer Precipitation Study 1981 .....	289
59. Laboratory Duplicate Data - The AOSERP Summer Precipitation Study 1982 .....	290
60. Laboratory Duplicate Data - The AOSERP Summer Precipitation Study 1983 .....	291
61. Laboratory Duplicate Data - The AOSERP Summer Precipitation Study 1984 .....	292
62. Laboratory Duplicate Data - The AOSERP Summer Precipitation Program .....	293
63. Laboratory Duplicate Data - The AOSERP Winter Precipitation Study 1984 .....	294
64. Laboratory Duplicate Data - The AOSERP Winter Precipitation Program in Comparison to the AOSERP Summer Precipitation Program .....	295
65. Replicate Data - The AOSERP Summer Precipitation Study 1976 .....	297
66. Replicate Data - The AOSERP Summer Precipitation Study 1977 .....	298
67. Replicate Data - The AOSERP Summer Precipitation Study 1978 .....	299
68. Replicate Data - The AOSERP Summer Precipitation Study 1979 .....	300
69. Replicate Data - The AOSERP Summer Precipitation Study 1981 .....	301
70. Replicate Data - The AOSERP Summer Precipitation Study 1982 .....	302
71. Replicate Data - The AOSERP Summer Precipitation Study 1983 .....	303
72. Replicate Data - The AOSERP Summer Precipitation Study 1984 .....	304

continued ...

LIST OF TABLES (CONCLUDED)

	Page
73. Replicate Data - The AOSERP Winter Precipitation Study 1976 .....	305
74. Replicate Data - The AOSERP Winter Precipitation Study 1978 .....	306
75. Replicate Data - The AOSERP Winter Precipitation Study 1981 .....	307
76. Replicate Data - The AOSERP Winter Precipitation Study 1983 .....	308
77. Replicate Data - The AOSERP Winter Precipitation Study 1984 .....	309
78. Replicate Data - The AOSERP Winter Precipitation Study 1984 .....	310
79. Summary of the Daily Efficiencies for Rain Samplers in the AOSERP Summer Precipitation Network .....	313

LIST OF FIGURES

	Page
1. The Alberta Oil Sands Environmental Research Program Study Area .....	4
2. Sequence of Processing .....	10
3. AOSERP Summer Sampling Sites .....	39
4. AOSERP Precipitation Collectors .....	59
5. AOSERP Snowcore Sampling Sites, 1983 to 1984 .....	72
6. Snow Corer .....	76
7. Winter Precipitation Chemistry Project Sample Collection Form .....	83
8. Chain-of-Custody Organization - Sample and Data .....	99
9. Key to Box Plots .....	148
10. Box Plots for the Annual Distribution of the Hydrogen Ion Concentration in Rain Samples in the AOSERP Network .	149
11. Box Plots for the Annual Distribution of the Sulphate Ion Concentration in Rain Samples in the AOSERP Network .....	150
12. Box Plots for the Annual Distribution of the Nitrate Ion Concentration in Rain Samples in the AOSERP Network .....	151
13. Box Plots for the Annual Distribution of the Chloride Ion Concentration in Rain Samples in the AOSERP Network .....	152
14. Box Plots for the Annual Distribution of the Calcium Ion Concentration in Rain Samples in the AOSERP Network .....	153
15. Box Plots for the Annual Distribution of the Magnesium Ion Concentration in Rain Samples in the AOSERP Network .....	154
16. Box Plots for the Annual Distribution of the Sodium Ion Concentration in Rain Samples in the AOSERP Network .....	155
17. Box Plots for the Annual Distribution of the Potassium Ion Concentration in Rain Samples in the AOSERP Network .	156
18. Box Plots for the Annual Distribution of Conductance in Rain Samples in the AOSERP Network .....	157

continued ...

LIST OF FIGURES (CONTINUED)

	Page
19. Box Plots for the Annual Distribution of the Ammonium Ion Concentration in Samples in the AOSERP Network .....	158
20. Annual Mean Sulphate Ion Concentrations at Selected Stations in the AOSERP Network .....	160
21. Annual Mean Hydrogen Ion Concentrations at Selected Stations in the AOSERP Network .....	161
22. Annual Mean Ammonium Ion Concentrations at Selected Stations in the AOSERP Network .....	162
23. Annual Mean Calcium Ion Concentrations at Selected Stations in the AOSERP Network .....	163
24. Annual Mean Sodium Ion Concentrations at Selected Stations in the AOSERP Network .....	164
25. Annual Isopleth (1984) for the Mean Sulphate Ion Concentrations in Rain Samples in the AOSERP Network ....	166
26. Monthly Isopleth (June 1984) for the Mean Sulphate Ion Concentrations in Rain Samples in the AOSERP Network ....	167
27. Annual Isopleth (1980) for pH of Rain Samples in the AOSERP Network .....	168
28. Annual Isopleth (1982) for Ammonium Ion Concentrations in Rain Samples in the AOSERP Network .....	169
29. Annual Isopleth (1984) for Nitrate Ion Concentrations in Rain Samples in the AOSERP Network .....	170
30. Annual Isopleth (1984) for Calcium Ion Concentrations in Rain Samples in the AOSERP Network .....	171
31. Box Plots for the Annual Distribution of Hydrogen Ion Concentrations in Snow Samples in the AOSERP Network ....	174
32. Box Plots for the Annual Distribution of Sulphate Ion Concentrations in Snow Samples in the AOSERP Network ....	175
33. Box Plots for the Annual Distribution of Ammonium Ion Concentrations in Snow Samples in the AOSERP Network ....	176

continued ...

LIST OF FIGURES (CONTINUED)

	Page
34. Box Plots for the Annual Distribution of Nitrate Ion Concentrations in Snow Samples in the AOSERP Network ....	177
35. Box Plots for the Annual Distribution of Na <sup>+</sup> in Snow Samples in the AOSERP Network .....	178
36. Box Plots for the Annual Distribution of K <sup>+</sup> in Snow Samples in the AOSERP Network .....	179
37. Box Plots for the Annual Distribution of Ca <sup>2+</sup> in Snow Samples in the AOSERP Network .....	180
38. Box Plots for the Annual Distribution of Mg <sup>2+</sup> in Snow Samples in the AOSERP Network .....	181
39. Box Plots for the Annual Distribution of Cl <sup>-</sup> in Snow Samples in the AOSERP Network .....	182
40. Box Plots for the Annual Distribution of Alkalinity in Snow Samples in the AOSERP Network .....	183
41. Box Plots for the Annual Distribution of Conductance in Snow Samples in the AOSERP Network .....	184
42. Annual Isopleth (1976) for Sulphate Ion Concentrations in Snow Samples in the AOSERP Network .....	185
43. Annual Isopleth (1978) for Sulphate Ion Concentrations in Snow Samples in the AOSERP Network .....	186
44. Annual Isopleth (1981) for Sulphate Ion Concentrations in Snow Samples in the AOSERP Network .....	187
45. Emission Sources of Potential Impact on the AOSERP Area .....	200
46. Monthly total Emissions and Volume Weighted Monthly Means for SO <sub>4</sub> <sup>2-</sup> in the AOSERP Network .....	203
47. Birch Mountain Lookout.....	225
48. Bitumont Lookout .....	226
49. Buckton Lookout .....	227

continued ...

LIST OF FIGURES (CONCLUDED)

	Page
50. Ells Lookout .....	228
51. Gordon Lake Lookout .....	229
52. Grande Lookout .....	230
53. Johnson Lake Lookout .....	231
54. Keane Creek Lookout .....	232
55. Legend Lookout .....	233
56. Mildred Lake Research Facility .....	234
57. Muskeg Mountain Lookout .....	235
58. Richardson Lookout .....	236
59. Stony Mountain Lookout .....	237
60. Thickwood Hills Lookout .....	238
61. Plot of 1983 Co-located Sampling Data for $\text{NH}_4^+$ .....	326
62. Plot of 1983 Co-located Sampling Data for $[\text{SO}_4^{2-} - \text{S}]$ ....	327
63. Plot of 1983 Co-located Sampling Data for $\text{NO}_3^-$ .....	328
64. Plot of 1983 Co-located Sampling Data for $\text{Cl}^-$ .....	329
65. Plot of 1983 Co-located Sampling Data for $\text{Na}^+$ .....	330
66. Plot of 1983 Co-located Sampling Data for $\text{Ca}^{2+}$ .....	331
67. Plot of 1983 Co-located Sampling Data for $\text{Mg}^{2+}$ .....	332
68. Plot of 1983 Co-located Sampling Data for pH .....	333
69. Plot of 1983 Co-located Sampling Data for Specific Conductivity .....	334

ABSTRACT

The data and network operating procedures from the precipitation and snow sampling networks in the AOSERP area of Alberta were reviewed and assessed. The data was first reformatted into NAQUADAT format and then quality assured by several screening procedures including outlier tests, simultaneous high concentration tests, and anion/cation ratios. A computer tape for the reformatted and screened data was produced. The data were also analysed statistically by factor analysis and other procedures to determine its reliability and level of confidence. A major deficiency found was the poor and highly variable collection efficiency for precipitation data which precluded conducting any detailed analysis. Since the determination of the environmental impact of two major pollution sources on precipitation quality in the study area was a primary project objective, poor collection efficiencies did not permit satisfaction of this objective.

Extensive evaluation was also made of the operational procedures for both the field and laboratory methods. While laboratory methods were generally found to be adequate in the later years (1983, 1984), field procedures, particularly the method of sampling, were determined to be inadequate to meet the operational objectives of the network. Other major deficiencies were the absence of a documented quality assurance plan, the generally low level of quality control in network operations, and a poor level of documentation for all aspects of network operation. These factors limited the ability to perform a comprehensive evaluation of the data. Recommendations for mitigating these problems are suggested in the report.



ACKNOWLEDGEMENTS

The authors would like to acknowledge the assistance of the Atmospheric Environment Service for supplying data, Merka Ondrack of York University for valuable comments on statistical interpretations, and B. Magill for advice and comments throughout the project and during preparation of the final report.

1.        INTRODUCTION

Precipitation and snowpack samples have been collected in a monitoring network in the oil sands of Alberta since 1976. This activity has been one of several conducted as part of the Alberta Oil Sands Environmental Research Program (AOSERP). AOSERP was established initially as a joint project funded by the Alberta Government and the Government of Canada. Since March 1979, AOSERP has been funded exclusively by the Alberta Government.

The monitoring data collected have been the subject of several reports that have dealt with various aspects of the data and network operation, but the overall assessment of the network and the data have not been systematically evaluated. Concord Scientific Corporation was commissioned to conduct such an evaluation of the network. The objectives of the study are as follows:

1. To subject the network operation and its data to quality control evaluation;
2. To transform the current database (which consists of a multiplicity of free format computerized files) into a consistent archive (in the NAQUADAT format);
3. To determine, through statistical and other analyses of the data, the temporal and spatial trends or patterns in the deposition of the monitored pollutants and to assess the historical impact of industrial development on precipitation quality in the study area;
4. To assess the suitability of the existing network and to recommend improvements; and
5. To conduct a preliminary assessment of the impact of future emissions from local industrial sources on precipitation quality in the network.

The remainder of this section describes the study area, summarizes the historical objectives of the network and the types of data collected, and also lists the previous related studies. This brief overview indicates the context in which the present study has been conducted.

Section 2 describes in detail the raw data available and how they were transformed into the prescribed NAQUADAT format. The pros and cons of the NAQUADAT system as it relates to the AOSERP precipitation and snowpack data are briefly discussed.

The assessment of the network and its operation over the years are presented in Section 3. The methodology for conducting this assessment is similar for both precipitation and snowcore monitoring, but separate sections dealing with these two aspects of the network operation are given. The laboratory procedures for the analysis of both types of samples have several common features, so a separate section on the quality control assessment of laboratory procedures is presented.

Section 4 describes the assessment of the data from the network. The data were screened by a variety of procedures to indicate suspect data. The quality assurance of precipitation and snowcore data were evaluated through the examination of intra- and inter-laboratory studies and field duplicates. Criteria were developed and applied to ensure data of known quality were retained for subsequent data analysis. Summaries of the retained and suspect data are given.

The statistical analyses applied to the data and their interpretation are described in Section 5. The analyses depict the temporal and spatial variability of the data and also identify inter-relationships between the monitored parameters and to a lesser extent, between stations. Periods during which elevated levels of certain pollutants in wet precipitation occurred (episodes) were identified and the meteorological features during these periods were evaluated.

Section 6 summarizes the data screening, the overall assessment of the network, and the interpretation of the data analysis. In addition, recommendations for improvement of all aspects of the network operation are presented.

## 1.1 OVERVIEW OF THE NETWORK

### 1.1.1 Description of the Study Area

The study area is located in northeastern Alberta between 56° and 59° north latitude (see Figure 1). The Athabasca river valley, which has a north-south orientation for some 200 km from Lake Athabasca to Fort McMurray and thereafter, and an east-west orientation along with the tributary Clearwater River, is the major topographical feature of the region. To the west of the Athabasca valley are the Birch Mountains (elevation up to 1000 m), and to the south of the east-west Athabasca-Clearwater River are the Stony Mountains, also rising to about 1000 m. Within the valley regions, the elevation is approximately 250 m, with gradually rising slopes to the mountains. The Muskeg Mountains are in the southeastern portion of the study area, just north of the Clearwater River. The surface deposits in the lowland regions are mainly glacial outwash, lake deposits, and windblown material. The higher elevations are mainly glacial tills.

The vegetation of the region is varied, with forested areas in the elevated areas and muskeg primarily in the lowlands. The forests are typical of northern Canadian boreal forests, with mixtures of pine, aspen, and white spruce stands interspersed between willow and black spruce.

Industrial development in the region is based on the presence of extensive deposits of bituminous material or oil sands. Two oil sands extraction plants have been constructed and are near the centre of the study area. The Great Canadian Oil Sands (GCOS) plant (renamed Suncor) was completed in 1969, while the Syncrude plant, located approximately 10 km northwest of the Suncor plant, began full production in July 1978. The largest urban centre in the region is Fort McMurray, with a population of 31 000 (Statistics Canada 1982). The emissions from the oil sands plants - primarily sulphur dioxide [147 100 t in 1980 (Colley et al. 1982)] and nitrogen oxides [9855 t as NO<sub>2</sub> in 1981 (Colley et al. 1983)] - are the dominant sources of acid forming pollutants in the study area, and indeed in the province.

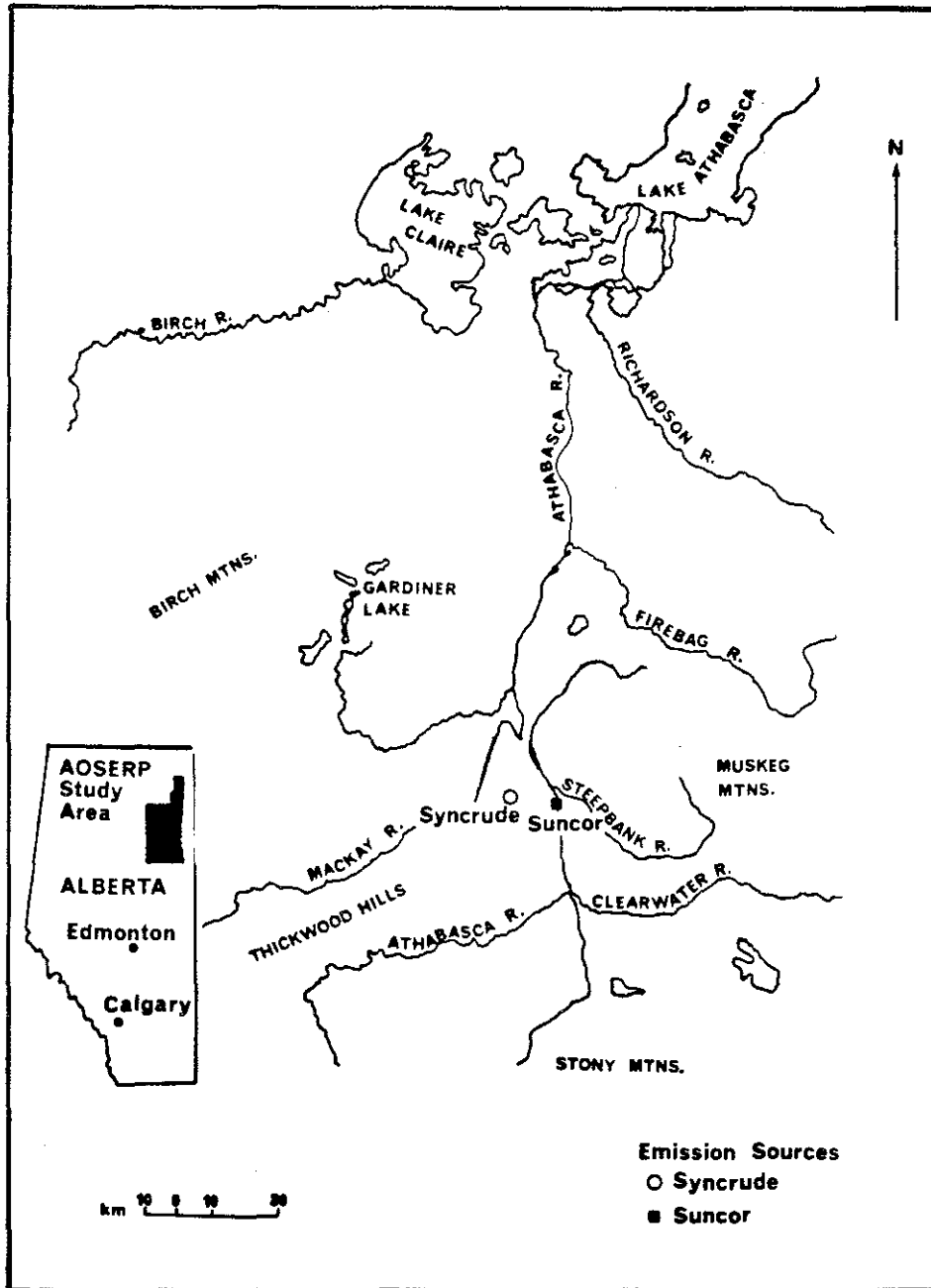

Figure 1. The Alberta Oil Sands Environmental Research Program study area.

### 1.1.2 Network Objectives

The AOSERP monitoring network was established in 1976 to monitor the chemistry of rain and snow deposited in the study area. The objectives of the network have been stated in several AOSERP and other reports. For example, Olson et al. (1982b) indicated that the main objectives were to:

1. determine changes in the deposition rate of atmospheric constituents, and
2. provide a database for the variations in the chemical characteristics in precipitation.

### 1.1.3 Data Availability

The monitoring data for precipitation (rain) have been acquired typically during the months of May to September each year between 1976 and 1984, except for the years 1980 and 1983. A summary of the number of stations and the range of parameters measured each year is given in Table 1. A similar summary for the snow studies, which were conducted during the months of January to March in 1976, 1978, 1981, 1983, and 1984, is given in Table 2.

### 1.1.4 Previous Related Studies

There have been several published reports describing the AOSERP precipitation and snowpack monitoring networks and statistical analysis of the data obtained from these networks. A summary of these reports and a brief description of each is found in Table 3.

Table 1. Summary of precipitation monitoring data available from the AOSERP monitoring network, 1976 to 1984.

Year	Number of Stations	Parameters Measured
1976	14(E)	pH, $\text{SO}_4^{2-}$ , $\text{NO}_3^-$ , $\text{Cl}^-$ , $\text{PO}_4^{3-}$ , $\text{NH}_4^+$ , $\text{Ca}^{2+}$ , $\text{Mg}^{2+}$ , $\text{Na}^+$ , $\text{K}^+$ , alkalinity, conductivity
1977	15(E) 4(F) 4(S)	pH, $\text{SO}_4^{2-}$ , $\text{NO}_3^-$ , $\text{Cl}^-$ , $\text{PO}_4^{2-}$ , $\text{NH}_4^+$ , $\text{Ca}^{2+}$ , $\text{Mg}^{2+}$ , $\text{Na}^+$ , $\text{K}^+$ , $\text{SiO}_2$ , alkalinity, conductivity
1978	14(E)	pH, $\text{SO}_4^{2-}$ , $\text{NO}_3^-$ , $\text{Cl}^-$ , $\text{PO}_4^{3-}$ , $\text{NH}_4^+$ , $\text{Ca}^{2+}$ , $\text{Mg}^{2+}$ , $\text{Na}^+$ , $\text{K}^+$ , alkalinity, conductivity
1979	14(E)	pH, $\text{SO}_4^{2-}$ , $\text{NO}_3^-$ , $\text{Cl}^-$ , $\text{PO}_4^{3-}$ , $\text{NH}_4^+$ , $\text{Ca}^{2+}$ , $\text{Mg}^{2+}$ , $\text{Na}^+$ , $\text{K}^+$ , alkalinity, conductivity
1981	14(E)	pH, $\text{SO}_4^{2-}$ , $\text{NO}_3^-$ , $\text{Cl}^-$ , $\text{PO}_4^{3-}$ , $\text{NH}_4^+$ , $\text{Ca}^{2+}$ , $\text{Mg}^{2+}$ , $\text{Na}^+$ , $\text{K}^+$ , $\text{Mn}^{2+}$ , $\text{F}^-$ , heavy metals, conductivity
1982	11(E)	pH, $\text{SO}_4^{2-}$ , $\text{NO}_3^-$ , $\text{Cl}^-$ , $\text{PO}_4^{3-}$ , $\text{NH}_4^+$ , $\text{Ca}^{2+}$ , $\text{Mg}^{2+}$ , $\text{Na}^+$ , $\text{K}^+$ , $\text{F}^-$ , heavy metals, conductivity
1983	1(E)	pH, conductivity, $\text{NH}_4^+$ , $\text{Br}^-$ , $\text{NO}_3^-$ , $\text{Cl}^-$ , $\text{SO}_4^{2-}$ , $\text{Ca}^{2+}$ , $\text{Mg}^{2+}$ , $\text{Na}^+$ , $\text{K}^+$
1984	17(E)	pH, $\text{SO}_4^{2-}$ , $\text{NO}_3^-$ , $\text{Cl}^-$ , $\text{PO}_4^{3-}$ , $\text{NH}_4^+$ , $\text{Ca}^{2+}$ , $\text{Mg}^{2+}$ , $\text{Na}^+$ , $\text{K}^+$ , alkalinity, acidity, conductivity, some organic acids, some heavy metals

E Event only samples

S Monthly bulk Sacramento sampler

F Monthly wet only Finnish sampler

Table 2. Summary of snow and snowcore monitoring data available from the AOSERP monitoring network, 1976 to 1984.

Year/Month	Number of Stations	Parameters Measured
1976 March	56	pH, conductivity, $\text{SO}_4^{2-}$ (top and bottom of core), snow depth, snow weight, crust depth
1978 January	60	pH, conductivity, alkalinity, $\text{SO}_4^{2-}$ , $\text{Cl}^-$ , $\text{NO}_3^-$ , $\text{NH}_4^+$ , $\text{K}^+$ , $\text{Na}^+$ , $\text{Mg}^{2+}$ , $\text{Ca}^{2+}$ , Al, Fe, Ni, V, soluble silica, snow-pack depth, snow density, snowmelt volume
1981 January	60	pH, conductivity, alkalinity, $\text{SO}_4^{2-}$ , $\text{Cl}^-$ , $\text{NO}_3^-$ , $\text{NH}_4^+$ , $\text{K}^+$ , $\text{Na}^+$ , $\text{Mg}^{2+}$ , $\text{Ca}^{2+}$ , Al, Cu, Fe, Ni, V, soluble silica, Mn, Ti
1983 February March	50	pH, conductivity, alkalinity, $\text{SO}_4^{2-}$ , $\text{Cl}^-$ , $\text{NO}_3^-$ , $\text{NH}_4^+$ , $\text{K}^+$ , $\text{Na}^+$ , $\text{Mg}^{2+}$ , $\text{Ca}^{2+}$ , Al, Mn, Ti, Fe, Ni, V, $\text{PO}_4^{3-}$ , soluble silica
1984 January February March	50	pH, conductivity, alkalinity, acidity, $\text{SO}_4^{2-}$ , $\text{Cl}^-$ , $\text{NO}_3^-$ , $\text{NO}_2^-$ , $\text{NH}_4^+$ , $\text{K}^+$ , $\text{Na}^+$ , $\text{Mg}^{2+}$ , $\text{Ca}^{2+}$ , Al, Ba, Li, Mn, Fe, Ni, V, Cu, Pb, As, B, Be, Bi, Cd, Co, Cr, Hg, Mo, Sb, Se, Th, U, Zn, Ba



Table 3. Summary of reports on data from the AOSERP precipitation and snowpack monitoring network.

Year	Title	Author	Reference	Comments
1977	Precipitation Chemistry Procedures Manual	Nespliak, V.E.	AES Western Region AOSERP	Procedures manual for 1977 summer precipitation chemistry study.
1978	Chemistry of Rain in the Athabasca Oil Sands Region	Barrie, L.A. et al.	Atmospheric Environment Service Report ARQT 3-78	The precipitation chemistry network is described and results for the summer of 1977 are presented and discussed.
1978	Meteorologic and Air Quality Winter Field Study in the AOSERP Study Area	Fanaki, F.	AOSERP Report #27	Describes intensive winter field study carried out in the AOSERP study area in 1976.
1980	A Wintertime Investigation of the Deposition of Pollutants Around an Isolated Power Plant in Northern Alberta	Barrie, L.A. and Kovalick, J.	AOSERP Report #90	This report presents a detailed and thorough analysis of the chemical content in the snowpack in the AOSERP study area in January 1978.
1981	The 1981 Snowpack Survey in the AOSERP Study Area, December 1981	Murray, W.A.	AOSERP Report #125	Analysis of 1981 snowpack data and sampling methodologies.
1981	An Analysis of Precipitation Chemistry in the Oil Sands Area of Northern Alberta	Peters, R.R. et al.		Preliminary analysis of 1976 to 1979 data. The reliability of the data without a quality assurance program was discussed.
1981	Precipitation Chemistry Procedures Manual	Peters, R.	RMD Alberta Environment	Procedures manual for summer 1981 precipitation chemistry study.
1982	Analysis of Event Rain Samples in Northeastern Alberta (see p. 22)	Olson et al.		The 1981 precipitation chemistry study is described and data were examined in terms of ionic concentrations and correlations.
1982	Athabasca Oil Sands Precipitation Chemistry Studies: 1976-1979 and 1981	Olson et al.	AOSERP Report #129	Describes techniques and procedures used in the 1970-1979 and 1981 precipitation chemistry field studies. The reliability and accuracy of the data were assessed in terms of methodologies employed in these studies.
1982	Precipitation Chemistry Procedures Manual, Athabasca Oil Sands Area	Olson, R.	RMD Alberta Environment	Procedures manual for summer 1982 precipitation chemistry study.
1984	Precipitation Chemistry Procedures Manual, Athabasca Oil Sands Area	Blower, L.	RMD Alberta Environment	Procedures manual for summer 1984 precipitation chemistry study.
1984	Preliminary Statistical Analysis of the 1983 Summer Precipitation Collected in the AOSERP Area in Northern Alberta	Blower, L.	RMD Alberta Environment	Preliminary analysis of the 1983 data using SAS (statistical analysis system) computer package. Several recommendations for implementation of a quality assurance program.
1984	Addendum to the Preliminary Statistical Analysis of the 1983 Summer Precipitation Collected in the AOSERP Area of Northeastern Alberta	Yurko, D.	RMD Alberta Environment	Further statistical analysis of the data from the 1983 study.

## 2. DATA VALIDATION

### 2.1 INTRODUCTION

One of the objectives of the project is to create a consistent, well characterized database that contains all the available monitoring data. The stipulated mechanism for achieving this was the transformation of the data into the National Water Quality Data (NAQUADAT) database format. In addition, data were required to be screened in order to identify and exclude suspect data, based on various criteria.

This chapter describes the procedures used to convert the raw data into the NAQUADAT format, and to screen data. In addition, selected data (parameters) after screening are cross-tabulated to indicate the number of samples available by type (rain or snowcore), year, station, and parameter. Additional information on the screened data are provided in Chapter 4. Information on the NAQUADAT database is provided along with a discussion of the advantages and disadvantages of the NAQUADAT system, and considerations of other approaches for data archiving. Recommendations for data retrieval and archiving of future similar monitoring data also are presented.

### 2.2 PROCEDURES FOR FILE CONVERSION AND SCREENING

An overview of the file conversion and screening procedures is illustrated in Figure 2, in which files are represented by ellipses, and processes by rectangles. One raw NAQUADAT file and one raw array file were generated for each raw data file. During the screening process, files with similar data were sorted and grouped by year (to be consistent with the screening methodology), so that the screened files (screened NAQUADAT, suspect sample data file, suspect parameter data file, and screened arrays) were grouped, by year, over raw files containing similar information. It should be noted, of course, that different sets of files were generated for the rain and snow data.

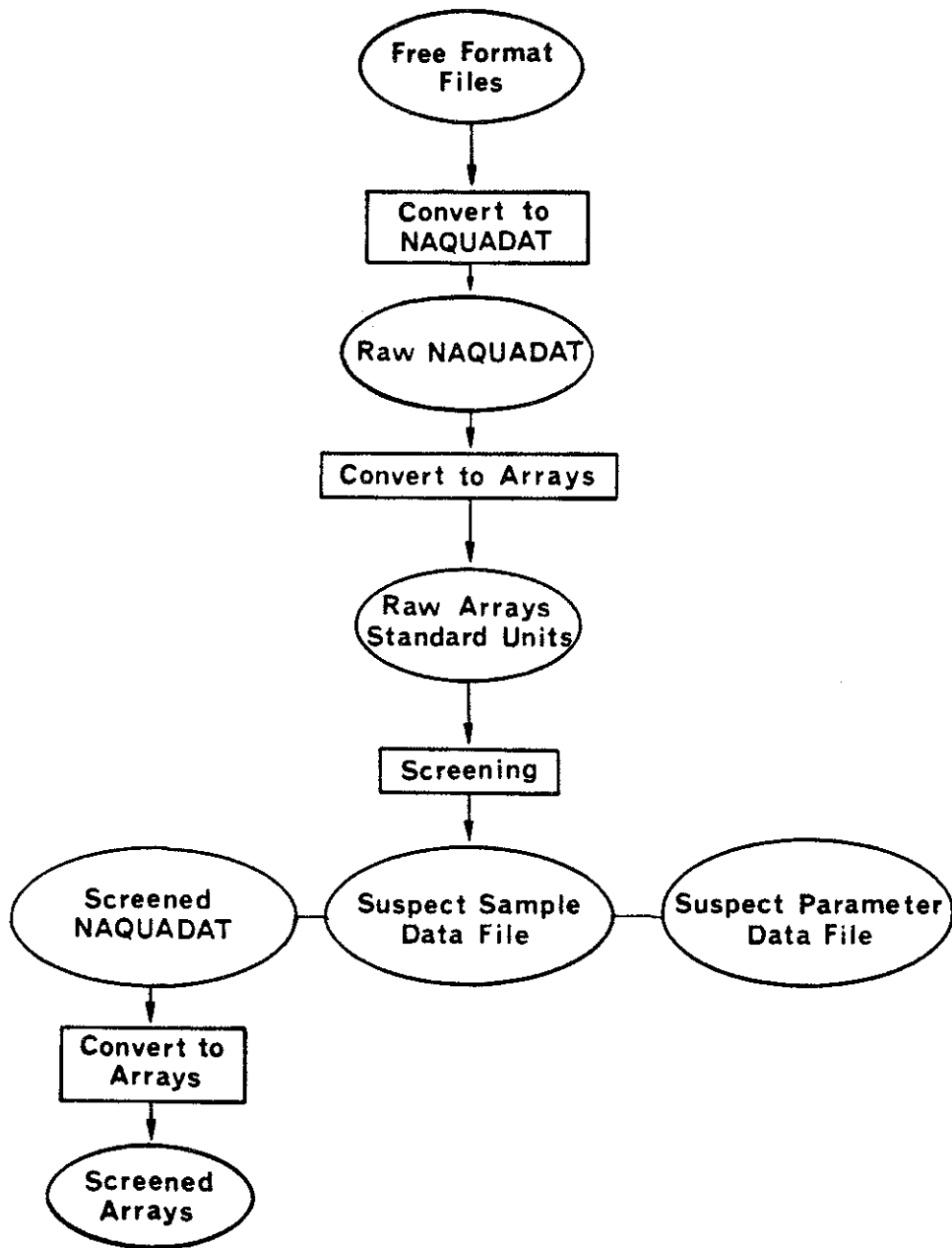

Figure 2. Sequence of processing.

## 2.2.1 Reformatting of Raw Data

2.2.1.1 Description of raw data. The data received on magnetic tape consisted of 29 files on which the data were encoded in free format. Most files contained comments at the beginning of the file that described the format in which data were encoded. No two files were identical, although (unfortunately) different information (i.e., parameters) for the same sample was often in different files. A list of the files is given in Section 8.1. Throughout the text, reference will be made to files by the index numbers indicated in Section 8.1.

Hardcopy listing of the files was provided, and it indicated that extensive editing of the data on some files was necessary. These files were edited accordingly before they were reformatted.

During the course of reformatting the data, several inconsistencies in the entries were corrected. These included typographical errors, different units and/or number of significant figures to which data were reported, inconsistent designation of missing and below detection limit entries, incorrectly designated units, missing or incomplete dates, poorly referenced sample identification, and inadequate sample description. Some files had extensive hardcopy additions or deletions, and these required manual data entry.

## 2.2.2 Description of the NAQUADAT Format

At the outset of the project, it was stipulated that the data should be converted into the NAQUADAT compatible format. Consequently, all file conversion procedures were directed to this end. During the course of the project, it became evident that alternate databases might be more suitable and should be considered. Notwithstanding, a description of the NAQUADAT file structure follows, and alternate database considerations for the historical and future data are discussed later in this chapter (Section 2.3 and 2.4).

The prescribed record structure for NAQUADAT records is reproduced in Table 4. The record consists of five types of sub-records, each describing the following:

Table 4. NAQUADAT record structure.

Record Type 01 - Station Header Information	
<u>Columns</u>	<u>Description</u>
1 to 2	Record Type (01)
3	Action (A-Addition, C-Change)
4 to 15	NAQUADAT Station Number
16 to 23	Not used
24	Sign of Latitude (always blank)
25 to 32	Latitude (format is DDMSS.SS)
33	Sign of Longitude (always blank)
34 to 42	Longitude (format is DDMSS.SS)
43	Precision of Latitude/Longitude
44 to 45	UTM/Zone
46	Sign of Northing (always blank)
47 to 54	Northing
55	Sign of Easting (always blank)
56 to 63	Easting
64	Precision of UTM Location
65 to 76	Reference Station
Record Type 02 - Additional Station Header Information	
<u>Columns</u>	<u>Description</u>
1 to 2	Record Type (02)
3 to 15	Same as Type 01
16 to 31	Not used
32 to 33	Line Number
34 to 71	Narrative Description
...	Note - there can be up to 5 type 02's per station
Record Type 03 - Site-Specific Parameters (not used)	
<u>Columns</u>	<u>Description</u>
1 to 2	Record Type (03)
3 to 15	Same as Type 01
32 to 37	Station Parameter
38 to 43	Value of Station Parameter
...	Up to 3 additional groups of parameter/values with the same format as 38-43 may be entered.

Continued...

Table 4. Concluded.

Record Type 04 - Sample-Specific Header Information	
<u>Columns</u>	<u>Description</u>
1 to 2	Record Type (04)
3	Action (A-Addition, C-Change, D-Delete, P-Parameter Code Change)
4 to 15	NAQUADAT Station Number
16 to 18	Not used
19 to 24	Date of Sampling from (Format DDMMYY)
25 to 28	Time of Sampling from (Format HHMM)
29 to 31	Time Zone
32 to 41	Date and Time of Sampling to (DDMMYYHHMM)
42	Precision of Sampling
43 to 44	Frequency of Sampling
45 to 46	Lab Code
47 to 53	Sample Number - Bell numbers probably
54 to 57	Submitter ID or Project Number
58 to 80	Submitter Description or Comments
Record Type 05 - Data (Parameter Values)	
<u>Columns</u>	<u>Description</u>
1 to 2	Record Type (05)
3 to 31	Same as Type 04
32 to 37	Parameter Code
38 to 43	Value for Parameter Code or New Parameter Code for an 05P Transaction
...	Up to 3 additional groups of parameter/values with the same format as 38-43 may be entered

1. station header information (columns 1 to 76),
2. additional station header information (columns 1 to 71),
3. site-specific parameters (columns 1 to 43),
4. sample-specific information (data header),
5. data (parameter values)(columns 1 to 43).

In addition to the summary information in Table 4, see Section 2.2.3 for further details on the NAQUADAT format.

Corresponding to each sample, there is a data header record (Record Type 04), and one or more data records (Record Type 05).

The data header describes the location, start, and end times for a sample. It also identifies the precipitation type, and contains instructions for programs that load NAQUADAT data into System 2000 databases. For complete details, see Section 2.2.3.2.

An example of a data header record is as follows:

```
04A30AT00000095    8306201500    8306210800    11
```

The above data header describes a rain sample (30) taken in Alberta (AT) at the Sandalta site (0095). The sampler was opened on June 20 1983 at 3:00 p.m. (8306201500), and the sampler was closed on the following day at 8:00 a.m. (8306210800). The precipitation type, province, and site code (30AT00000095), in NAQUADAT jargon, is called a station number.

A station number and a sample start time, together, uniquely identify each sample within a NAQUADAT database, and are referred to as a sample ID.

Every data record contains a sample ID, which is followed by up to four so called parameter value groups. The parameters describe the meaning of the values.

The following is a typical data record corresponding to the data header described above:

```
05A30AT00000095    8306201500    99502E2    97160E1    97181E50    97351E49.2
```

The first parameter is 99502E and the corresponding value is 2. Details on the parameter codes are given in Section 2.2.3.

### 2.2.3 Procedure for Reformatting Data

A general-purpose skeleton program was developed to reformat each file. This program allowed the user to interactively define the structure of each file, and accommodate any peculiar features of each file.

The ancillary NAQUADAT files required (i.e., those with station and parameter information), were generated by examining the information on AOSERP NAQUADAT sampling sites available and through consulting the NAQUADAT Dictionary of Parameter Codes. In cases where there was incomplete station location information (i.e., latitude and longitude), AOSERP publications were consulted. The mid-point between the Syncrude and Suncor plants was determined and used as a reference point for calculating the orientation (degrees from true north) and distance of each station from the reference point. The station location information supplied in the raw data files was recoded into numeric station codes to facilitate sorting. Table 5 details the original station information together with the assigned station numbers.

The following is a summary of the extensions to the NAQUADAT format that were necessary, and descriptions of the rain and snow arrays generated during the screening process.

#### 2.2.3.1 Extensions to NAQUADAT

1. Laboratory duplicates are indicated by a one-minute difference in their sample start times.
2. Field duplicates are indicated by a one-hour difference in their sample start times.
3. A missing day in the dates is indicated by a zero-day in their sample start times. (It was also necessary to arbitrarily assign dates where there were missing month and day values. Tabulations of all such dates are provided in Table 6.)
4. Blank samples are indicated by the 9999 site code.
5. The raw data were originally in 29 files. The files were numbered consecutively from 1 to 29. These file



Table 5. List of stations.

CSC Assigned Station Number	Location	Abbreviation	Raw Data Files
0001		AN1	13
0002		AN2	13
0003		AN3	13
0004	Alberta-Saskatchewan Border Lake	ASB	17 to 8
0005	Birch Mountain	BCH,BIRCH	12,19,20 to 1, 23 to 6
0006	Buckton Lookout	BKN,BUCKTON	4,7,12,19,20,23,25 to 6
0007		BM	14 to 8
0008	Clark Creek	CLK	19,20
0009		CSR	14
0010	Dunkirk	DNK	19,20
0011		B1	14 to 8
0012	Small pond to NE of site	E2	14 to 9,20
0013		E3	14 to 8
0014	Small pond	E4	4,15 to 9,20
0015	Ells Tower/River	ELS,ELLS	2,7,12,19,20 to 1,23 to 6
0016	Edra	ERA,EDRA	19,20,25
0017	Firebag	FBG	13,17 to 9,20
0018	Fort McMurray Airport	FMA	13,19,20
0019		FMM	13
0020		G1	14 to 8
0021		G2	14
0022		G3	14
0023		G4	14
0024		G5	14 to 8
0025		G6	14
0026		G7	14
0027		GC	17 to 8
0028	Grande Tower Lookout	GDE,BND,GRANDE	7,12,119,20 to 1,23 to 4,26
0029	Gordon Lake	GDM,GORDON,GLK	12,17 to 9,20 to 1,23 to 6
0030	High Hills River	HHR	19,20
0031		HKM	13
0032	Fort Hills = Bitumont Tower	HLS,BITUMONT	12,19,20 to 1,23 to 6
0033	Jean Lake	JLK	13,25 to 6
0034	Johnson Lake Lookout	JSN,JOHNSON	4,12,19,20 to 1,23 to 6
0035	Keane Creek Tower	KNE,KEANE	21,23 to 6
0036		KLK	13
0037		LB	14
0038		LBH	13
0039		LC	15 to 6
0040	Lost Creek (=LC??)	LCK	13,19,20
0041	Legend Tower/Logkout	LGD,LEGEND	12,21,23 to 6
0042	Long Rapid	LGR	19,20
0043		LIVOCK	12

continued ...

Table 5. Continued.

CSC Assigned Station Number	Location	Abbreviation	Raw Data Files
0044		LTL	13
0045		LS	15 to 8
0046		M	15 to 6
0047,	Muskeg Mountain Lookout	MKG,MUSKEG	12,17 to 9,20 to 1,23 to 6
0048	Mackay River	MKY,MKR	13,19,20
0049		MTR	13
0050	Off Hw. 63,N of SUNCOR's little lake	N1	4,14 to 9,20
0051	Mildred Lake (=AOSERP camp=LKM camp)	N2,LKM,AOSERP, MILDLK,MLK	12,15 to 9,20 to 1,23 to 6
0052		N3	14,15 to 8
0053	Junction of Rivers	N4	4,14 to 9,20
0054		N5	14 to 8
0055	Pond	NE1	14 to 9,20
0056		NE2	14 to 8
0057	Small pond W of river	NE3	14 to 9,20
0058		NE4	14 to 8
0059	N edge of small pond	NE5	14 to 9,20
0060	Namur Lake	NLK	13,19
0061		NHL	20
0062	S of Island; East side of river	NNE1	15 to 9,20
0063		NNE2	15 to 8
0064	Near edge of lake	NNE3	15 to 9,20
0065	Marked on N side of creek bend	NNE4	4,15 to 9,20
0066		NW1	14
0067		NW2	14
0068	1.6 km E of Mackay R., small pond	NW3	4,14 to 9,20
0069		NW4	14 to 8
0070		NW5	14 to 8
0071	New Lake	NWL	19,20
0072	NW end of island	RO	4,19,20
0073	Sand bar S of island	R1	15 to 9,20
0074	S of island to the east	R2	4,15 to 9,20
0075	E side of river, opposite SUNCOR dyke	R3	4,15 to 9,20
0076	NE of lower Syncrude tall tower	R4	15 to 9,20
0077	Richardson	RIC,RICHARDSON	12,13,19,20,23,26 to 6
0078		RN1	14
0079		RN2	14
0080		RN3	14
0081		RN4	14
0082		RN5	14
0083		RN6	14

continued ...

Table 5. Concluded.

CSC Assigned Station Number	Location	Abbreviation	Raw Data Files
0084		RS1	14
0085		RS2	14
0086		RS3	14
0087		RS4	14
0088		RS5	14
0089		RRR	13
0090		S1	14 to 8
0091		S2	14 to 8
0092		S3	14 to 8
0093		S4	14 to 8
0094		S5	14 to 8
0095	Sandalta Station (NE of Fort McMurray)	SANDALTA,SANDAL	many files
0096		SE1	14 to 8
0097		SE2	14 to 8
0098	Steepbank River/Middle of river	SE3,	13 to 9,20,25
0099		SE4	14 to 8
0100	Small pond	SE5	4,14 to 9,20
0101		SHC	13
0102		SHH	13
0103	Stony Mountain Tower/Lookout	SMT,STONY,YMT	2,12,15 to 9,20 to 1,23 to 6
0104		SSE1	15 to 8
0105		SSE2	15 to 8
0106		SSE3	15 to 8
0107	In slough by cutline	SSW1	15 to 9,20
0108		SSW2	15 to 8
0109	On Hydro line, W of lines E of trees	SW1	4,14 to 9,20
0110		SW2	14 to 8
0111	S edge, small beaver pond	SW3	14 to 9,20
0112		SW4	14 to 8
0113	N edge of lake	SW5	4,14 to 9,20
0114		SW11	14
0115	Thickwood Hills Tower/Lookout	TKW,THICKWOOD, TWD,TCK,NNWI	12,13,15,to 9,20 to 1, 23 to 6
0116		TMY	13
0117		UT	14,16
0118	Upper Tar Lake (=UT ??)	UTL	13,19,20
0119	Pond	W1	15 to 9,20
0120		W2	15 to 8
0121	Beaver pond, follow power line	W3	15 to 9,20
0122	Wood Creek	WCK	4,19,20
0123	Wolf Lake	WLK	4,3,19,20

No site hints in files 6, 22

File 25 uses numbers (1 to 16) to identify sampling sites

Table 6. Summary of arbitrarily assigned dates due to missing or incomplete information.

File	Number	Station	Assigned Date	Time
28	41		84 06 00	1430
	304	ERA	84 07 00	
	305	ERA	84 06 00	0900
	306	ERA	84 06 00	1100
	307	ERA	84 07 00	0000
	308	ERA	84 07 00	0200
	309	ERA	84 07 00	0400
	328	N2	84 06 00	1300
	329	N2	84 06 00	1500
	335	95	84 08 00	2100
	336	95	84 08 00	2300
	395	N2	84 08 00	1500
	45	NNE	84 06 00	0003
	49	NNE	84 06 00	0203
	59	95	84 06 00	0403
	215	Missing <sup>1</sup>		
	239	ELS		
	104	ELS	84 06 00	0603
	105	ELS	84 06 00	0700
	30		84 06 01	0000
	47	35	84 06 00	2000
	48	35	84 06 00	1230
	72	51	84 06 00	2000
	103	15	84 06 17	0000
	105	15	84 06 00	0700
	259	15	84 07 00	1301
	260	15	84 07 21	0000
	288	15	84 08 12	0000
	305	16	84 08 12	0900
	306	16	84 06 00	1100
	328	51	84 06 00	1300
	329	51	84 06 00	1500
	333	95	84 08 00	1700
	334	95	84 08 00	1900
	335	95	84 08 00	2100
	336	95	84 08 00	2300
	381	115	84 08 27	0000
	383	115	84 08 28	0000
	386	115	84 09 01	0000
	387	43	84 08 15	0000
	390	43	84 08 27	0000
	391	43	84 08 27	0200
	393	103	84 08 27	0400
	394	103	84 08 28	0600
	395	51	84 08 00	1500
	397	51	84 08 00	1700
	398	95	84 08 27	0000
	399	95	84 08 29	0000

<sup>1</sup>Record deleted.

numbers are stored in the laboratory code field of the data header records.

6. Below detection limit measurements, where the detection limit was not known, are indicated by -77. If the detection limit was known, then samples initially reporting values less than the detection limit were assigned values one-half the detection limit.
7. Some parameters, such as event start and event end times, which do not correspond to any entry in the Dictionary of Parameter Codes, were assigned unrelated, but valid, parameter codes from the Dictionary.
8. Precipitation codes were assigned as follows:
 

rain	- 30
snow	- 31
snowcore	- 00
snowcore blanks	- 09
rain blanks	- 89

Some of these extensions to the NAQUADAT format were accommodated in the customized program for each file, but invariably there was the need to manually insert values into the converted file. It should be noted that these extensions also were incorporated into the raw and screened arrays.

2.2.3.2 Raw arrays. The following arrays were obtained by conversion of the NAQUADAT files. There are two types of arrays.

1. Snow arrays. The following shows the format of one snow array record:

<u>Columns</u>	<u>Field Name &amp; Description</u>	<u>Fortran Format</u>
1 to 15	Station ID	a15 [15 chars.]
16 to 25	Sample start date & time (YYMMDDHHMM)	a10
26 to 35	Sample end date & time (YYMMDDHHMM)	a10
36 to 45	GC distance (distance in kilometers from reference point i.e., midpoint between Sycrude & Suncor)	a10
46 to 55	Direction (direction from true north of station with respect to the reference point)	a10
56 to 757	117 screenable parameters*	117 x (a6) [117 x 6 characters]
758 to 979	37 unscreenable parameters	37 x (a6) 979 characters/ record

\*"-99" indicates missing parameter values

Tables 7 and 8 contain lists of the screenable and unscreenable parameters respectively, the NAQUADAT codes, and the units in the arrays.

2. Rain arrays. The following shows the format of one rain array record:

<u>Columns</u>	<u>Field Name &amp; Description</u>	<u>Fortran Format</u>
1 to 15	Station ID	a15 [15 chars.]
16 to 25	Sample start date & time (YYMMDDHHMM)	a10
26 to 35	Sample end date & time (YYMMDDHHMM)	a10
36 to 45	GC distance (distance in km from reference point i.e., midpoint between Syncrude & Suncor)	a10
46 to 55	Direction (direction from true north of station with respect to the reference point)	a10
56 to 757	117 screenable parameters*	117 x (a6) [117 x 6 characters]
758 to 1009	42 unscreenable parameters	42 x (a6) 1009 chars./ record

\*"-99" indicates missing parameter value

Table 7. Screenable parameters.

Index (a)	Parameter Codes	Descriptions	Standard Units
1	13102E	Al (dissolved)	mg/L
2	13004E	Al (undissolved)	mg/L
3	33101E	As (dissolved)	mg/L
4	33001E	As (undissolved)	mg/L
5	05103E	B (dissolved)	mg/L
6	05001E	B (undissolved)	mg/L
7	56101E	Ba (dissolved)	mg/L
8	56001E	Ba (undissolved)	mg/L
9	04101E	Be (dissolved)	mg/L
10	04001E	Be (undissolved)	mg/L
11	18925E	Bi (dissolved)	mg/L
12	18935E	Bi (undissolved)	mg/L
13	35201M	Br (dissolved)	mg/L
14	18900E	Br (undissolved)	mg/L
15	20102E	Ca (dissolved)	mg/L
16	20003E	Ca (undissolved)	mg/L
17	48101E	Cd (dissolved)	mg/L
18	48001E	Cd (undissolved)	mg/L
19	17201E	Cl (dissolved)	mg/L
20	17101E	Cl (undissolved)	mg/L
21	24052E	Cr (dissolved)	mg/L
22	24002E	Cr (undissolved)	mg/L
23	29101E	Cu (dissolved)	mg/L
24	29001E	Cu (undissolved)	mg/L
25	26101E	Fe (dissolved)	mg/L
26	26003E	Fe (undissolved)	mg/L
27	80101E	Hg (dissolved)	mg/L
28	80011E	Hg (undissolved)	mg/L
29	19101E	K (dissolved)	mg/L
30	19001E	K (undissolved)	mg/L
31	03101E	Li (dissolved)	mg/L
32	03001E	Li (undissolved)	mg/L

continued...

Table 7. Continued.

Index (a)	Parameter Codes	Descriptions	Standard Units
33	12102E	Mg (dissolved)	mg/L
34	12001E	Mg (undissolved)	mg/L
35	25104E	Mn (dissolved)	mg/L
36	25004E	Mn (undissolved)	mg/L
37	42101E	Mo (dissolved)	mg/L
38	42001E	Mo (undissolved)	mg/L
39	11101E	Na (dissolved)	mg/L
40	11001E	Na (undissolved)	mg/L
41	28101E	Ni (dissolved)	mg/L
42	28001E	Ni (undissolved)	mg/L
43	15314E	P (dissolved)	mg/L
44	15422E	P (undissolved)	mg/L
45	82101M	Pb (dissolved)	mg/L
46	82001E	Pb (undissolved)	mg/L
47	16101E	S (dissolved)	mg/L
48	16001E	S (undissolved)	mg/L
49	51101E	Sb (dissolved)	mg/L
50	51001E	Sb (undissolved)	mg/L
51	34301E	Se (dissolved)	mg/L
52	34001E	Se (undissolved)	mg/L
53	14201E	Si (dissolved)	mg/L
54	14050E	Si (undissolved)	mg/L
55	50101E	Sn (dissolved)	mg/L
56	50005E	Sn (undissolved)	mg/L
57	38101E	Sr (dissolved)	mg/L
58	38001E	Sr (undissolved)	mg/L
59	18908E	Th (dissolved)	mg/L
60	18918E	Th (undissolved)	mg/L
61	22111E	Ti (dissolved)	mg/L
62	22011E	Ti (undissolved)	mg/L
63	92101E	U (dissolved)	mg/L
64	92111E	U (undissolved)	mg/L

continued...



Table 7. Continued.

Index (a)	Parameter Codes	Descriptions	Standard Units
65	23101E	V	mg/L
66	23001E	V	mg/L
67	30101E	Zn	mg/L
68	30001E	Zn	mg/L
69	18903E	Zr	mg/L
70	18913E	Zr	mg/L
71	06302E	CO <sub>3</sub>	mg/L
72	09101E	F	mg/L
73	10300E	pH (unspecified)	pH units
74	07501E	NH <sub>4</sub> <sup>+</sup>	mg/L
75	07503E	[NH <sub>4</sub> N]	mg/L
76	07207E ddddd	NO <sub>2</sub> <sup>-</sup>	mg/L
77	07306E	NO <sub>3</sub> <sup>-</sup>	mg/L
78	07307E	[NO <sub>3</sub> N]	mg/L
79	15280E	PO <sub>4</sub> <sup>=</sup>	mg/L
80	14103E	SiO <sub>2</sub> <sup>=</sup>	mg/L
81	16304E	SO <sub>4</sub> <sup>=</sup>	mg/L
82	16305E	[SO <sub>4</sub> <sup>=</sup> ]	mg/L
83	27101E	Co (dissolved)	mg/L
84	27001E	Co (undissolved)	mg/L
85	16001P	S (at top of core)	mg/L
86	16001A	S (at bottom of core)	mg/L
87	10101E	Alkalinity	μequ/L
88	97168P	Organic acids (others)	mg/L
89	02041E	Specific conductivity	μS/cm
90	02045E	Conductivity (top of core)	μS/cm
91	02047E	Conductivity (bottom of core)	μS/cm
92	10300F	pH (field)	pH units
93	18651F	pH (field)	μequ/L
94	18656F	pH (field)	mg/L of
95	10300L	pH (lab)	pH units
96	18651L	pH (lab)	μequ/L
97	18656L	pH (lab)	mg/L

continued...

Table 7. Concluded.

Index <sup>a</sup>	Parameter Codes	Descriptions	Standard Units
98	10301E	pH (at top of core)	mg/L
99	10302E	pH (at bottom of core)	pH units
100	97165E	Organic acids (formate)	pH units
101	97165P	Organic acids (formate)	mg/L
102	97166E	Organic acids (acetate)	ppm
103	97166P	Organic acids (acetate)	mg/L
104	97167E	Organic acids (propionate)	ppm
105	97167P	Organic acids (propionate)	ppm
106	97168E	Organic acids (others)	mg/L
107	20101E	Ca <sup>2+</sup>	mg/L
108	17202E	Cl <sup>-</sup>	mg/L
109	19102E	K <sup>+</sup>	mg/L
110	11102E	Na <sup>+</sup>	mg/L
111	35201E	Br <sup>-</sup>	mg/L
112	12103E	Mg <sup>2+</sup>	mg/L
113	99503E	Acidity	μequ/L
114	10201E	Acidity (total titratable)	μequ/L
115	10210E	Acidity (total titratable duplicate)	μequ/L
116	10211E	Acidity (strong titratable)	μequ/L
117	10251E	Acidity (strong titratable duplicate)	μequ/L

<sup>a</sup> The starting column of screenable parameter in the array will be 56 + 6 (Index -1).

Table 8. Unscreenable parameters.

Index <sup>a</sup>	Parameter Codes	Descriptions	Standard Units
118	97011E	Bulk rain gauge amount	mm
119	18621E	Comments (codes)	
120	97160E	Container (bag or bottle)	
121	97357E	Exposure time	1/100 h
122	98090E	Grass or ice beneath core	
123	98070E	Filtered sample	
124	97163E	Laboratory code (flag)	
125	18632E	Major ion volume	mL
126	18611E	Precipitation type	
127	18606E	Rain gauge reading for collected portion	1/10 mm
128	97181E	Sample bottle size	
129	97164E	Sample preparation (code)	mL
130	80601E	Sample row number	
131	97351E	Sample volume collected	mL
132	18629E	Sample volume measured in lab	mL
133	99501E	Sample volume filtered	mL
134	97251E	Snowcore depth	cm
135	97261E	Snow crust depth	cm
136	97315E	Snow depth	cm
137	36102E	Snow density	g/cm <sup>3</sup>
138	36103E	Snow weight	g
139	36110E	Water equivalent	g
140	99502E	Stand (on ground or on stand)(flag)	
141	97010E	Total tipping bucket amount	1/10 mm
142	97162E	Treatment	
143	98040E	Type of test	
144	97080E	Wind direction & speed (at start of collection)	sector, km/h
145	97081E	Wind direction & speed (at end of collection)	sector, km/h
146	97090E	Wind direction & speed (average during collection)	sector, km/h
147	98030E	Number of cores taken	
148	98031E	Mean snow depth	cm
149	97320E	Snowmelt metal volume	mL
150	97170E	Sampler cross-section	cm <sup>2</sup>
151	98035E	Total area sampled	cm <sup>3</sup>
152	97172E	Event number	
153	97174E	Sample type	
154	06201E	HCO <sub>3</sub>	μequ/L
155 <sup>b</sup>	97361E	Event start date (YYMMDD)	
156 <sup>b</sup>	97070E	Event start time (HHMM)	
157 <sup>b</sup>	97362E	Event end date (YYMMDD)	
158 <sup>b</sup>	97071E	Event end time (HHMM)	
159 <sup>b</sup>	97183E	Unused	

<sup>a</sup>The starting column of all unscreenable parameters is at 56 + 6 x (Index-1).

<sup>b</sup>The last 5 unscreenable parameters are only in the rain arrays.

2.2.3.3 Screened NAQUADAT. These are the NAQUADAT data files that are obtained when the raw arrays are processed through the screening programs. These files hold the data that are acceptable according to the screening criteria. The format of these files is exactly the same as the raw NAQUADAT files.

2.2.3.4 Suspect data files. These data files were produced by the screening program. There are two suspect data files.

1. Suspect sample data files. The format of the suspect sample data file is as follows:

<u>Columns</u>	<u>Field Name &amp; Description</u>	<u>Fortran Format</u>
1 to 15	Station ID	a15 [15 chars.]
16 to 25	Sample start date & time (YYMMDDHHMM)	a10
26 to 40	"Sample flag="	a15
41	Contamination flag	i1 [1 digit integer]
42 to 52	"A/C flag="	a11
53	Anion/cation flag	a1
54	Field separator	1 x [1 blank]
55 to 756	117 screenable parameters	117 x (a6) [117 x 6 chars.] 756 chars./record

These files contain the screenable parameters of those records that were identified because of potential sample contamination or because the anion/cation ratio was not within the prescribed boundaries. The files also contain the screenable parameters of those samples for which there is no likelihood of contamination. However, if the anion/cation ratio is missing, these samples are also included in the screened NAQUADAT file.

2. Suspect parameter data file. The following shows the format of the suspect parameter data file:

<u>Columns</u>	<u>Field Name &amp; Description</u>	<u>Fortran Format</u>
1 to 15	Station ID	a15 [15 chars.]
16 to 25	Sample start date & time (YYMMDDHHMM)	a10
26	Field separator	1 x [1 blank]
27 to 728	117 screenable parameters	117 x (a6) [117 x 6 chars.] 728 chars./record

These files contain the screenable parameters of all records. If the parameter value is missing or the value is greater than the mean plus two standard deviations, then the value appears in this file. Parameter values that are greater than the mean plus two standard deviations will not appear in the final screened NAQUADAT or screened arrays.

2.2.3.5 Screened arrays. These are the array files obtained when the screened NAQUADAT data files are converted to array form. These arrays are in the same format as the raw arrays.

Some records in the arrays do contain some duplicated information in cases where the original files were similarly duplicated. Such duplicate records were merged for statistical analyses (see Chapter 5).

## 2.3 DATA AVAILABILITY

Detailed tabulations of data availability (e.g., by year, station, month, parameter) would be extensive in view of the large number of parameters. Instead, tabulations for samples in the screened arrays for selected parameters are provided as separate computer listings. The parameters selected are those used for statistical analyses in chapters 4 and 5. The parameters include the metals Al, Fe, Mn, and Ni (dissolved and undissolved), the ionic species  $\text{Na}^+$ ,  $\text{K}^+$ ,  $\text{NH}_4^+$ , pH,  $\text{Mg}^{2+}$ ,  $\text{Ca}^{2+}$ ,  $\text{Cl}^-$ ,  $\text{NO}_3^-$ , and  $\text{SO}_4^{2-}$ , and the unscreenable parameters s-vol (volume of rain collected), rain gauge data, and snowcore depth. It should be noted that Chapter 4 includes

a discussion on the amount of data for all parameters placed in the suspect data file together with reasons for their presence in that file.

The lack of data for the volume of rain sample collected for the years prior to 1981 should be noted. Based on information on the raw free format data, this parameter was not scheduled for measurement in those years. In view of this, it is not possible to calculate volume-weighted mean concentrations for years prior to 1981.

#### 2.4 RECOMMENDATIONS FOR THE AOSERP DATABASE

The monitoring activities of the AOSERP network can generate approximately 117 raw data values per event assuming all analyses are performed.

The database is therefore large enough to warrant well designed database management tools. It is clear that the existing system using the "free format" files is totally inadequate and unacceptable.

The request for proposal suggested that the NAQUADAT database, which employs the System 2000 database management system (DBMS), be used as a likely repository for data storage, manipulation, and reporting. The System 2000 (S2K) DBMS, which is based on a hierarchical structure, has been in use for several years and although it provides a powerful tool for data management, current technology invariably points to the selection of a relational DBMS.

Consequently, several recent or ongoing projects in which environmental databases (with monitoring data) are being developed, have utilized relational databases. Some of the most important databases are listed on page 30.

<u>Organization/Data Type</u>	<u>DBMS</u>
U.S. EPA (includes all SAROAD U.S. air quality data)	ADABAS
Digital Archive, Canadian Meteorological Data (meteorological and air quality including precipitation data in CAPMoN)	Model 204
National Air Pollution Surveillance (NAPS) (Canadian air quality data in the NAPS network)	Model 204
Acid Deposition System (ADS) (U.S. precipitation networks)	DATATRIEVE

In making recommendations for the repository of AOSERP data, several factors need to be considered and addressed. These factors include:

1. available resources,
2. data users' requirements, and
3. software selection.

A detailed evaluation of these aspects is beyond the scope of this report, but will be briefly addressed.

1. Available resources.

The available resources include both computer hardware and human resources - namely Research Management Division (RMD) staff identified as data users. The hardware aspects will not be addressed since it is assumed that existing facilities (viz. IBM 3084 Q mainframe) will continue to be available.

The data users ideally should have rapid and facile access to the data so that database update, data validation (data quality assurance and quality control), and reporting may take place in a convenient and timely manner. In the case of RMD, it would be

necessary to provide staff (computer programmers, research scientists, and senior administrative staff) with appropriate training in the use and/or applicability of DBMS.

It should be stressed that such training would not necessarily involve the requisition of "hands-on" capability for all staff (e.g., senior management staff), but it would provide an overview of the DBMS of choice with respect to the capabilities and limitations of the system.

## 2. Data users' requirements.

In the case of AOSERP monitoring data, the following users' requirements are envisaged:

- a) facile database updating in an on-line or batch environment depending on the volume of data;
- b) on-line database validation;
- c) generation of standard reports via on line job submission and batch processing;
- d) on-line database inquiry for generating relatively short reports on user-selected information;
- e) archiving and retrieving the data in the DBMS host or user language format as well as in a regular standard flat file or other appropriate format (for data transfer to other computer systems).

Based on the information provided in this report, there has been no systematic or prescribed documented procedures for data validation. It is essential that such procedures be implemented. Data validation should include the following:

1. Design of sample documentation (e.g., field sheets, chain of custody sheets, laboratory reports) to facilitate data entry;
2. Implementation of procedures to routinely enter and verify data entry;
3. Design of data validation protocols to
  - a) flag all appropriate parameters,
  - b) indicate appropriate descriptions of the sample at



each stage (environmental conditions, sample handling/transport, analysis, status in database) of the monitoring process, and

c) identify suspect data for follow-up investigation if necessary;

4. Assignment of responsibility and authority for database editing and establishment of criteria and protocols for database editing.

In the case of data validation protocols, those being developed for the CAPMoN database are outlined to illustrate the requirements.

In the CAPMoN database, measured values are assigned up to three flags to indicate valid, invalid, or valid-but-qualified typical data (personal communication, September 1984, R. Vet, Atmospheric Environment Service, Environment Canada, Downsview, Ontario). Furthermore, each flag may have up to 10 sublevels to detail the attributes of the flag in question. The assignment of the flag attributes is intended to provide data users with all necessary information to allow educated choice of data that may be included in user-specific statistical analyses or reporting. The data validation process is such that all information on samples containing suspect parameter(s) are identified in an on-line interactive environment and appropriate (authorized) editing may take place.

3. Software selection.

The recommendation of specific software for application to the AOSERP precipitation database ideally should be made after reaffirmation of the network objectives and program requirements. Thus, all operational and reporting aspects must be defined prior to this step. It is somewhat premature at this stage to make recommendations on specific software to be used, but a practical approach to satisfy the immediate and future requirements is outlined below.

Regardless of the software (DBMS) selected in the future, all future data should be placed in a consistent and regular computerised format. The format for historical data provided in this project will serve as a basis. This format should be reviewed to

verify that any changes recommended in operational and quality assurance/quality control aspects of network operation are consistent with the format (to ensure that laboratories and field duplicates, replicates, and/or blanks are adequately characterized, for example). Thus, the "one-minute difference" that distinguishes replicates may be inadequate if special studies use 15-minute collection intervals for rain events. The data also should be accumulated in a manner that will exclude multiple records of the same sample. Parallel flag files or suspect data files also may be generated (with a similar format at least in the sequence of parameter fields). Such files will serve as easily readable input to the DBMS.

Although a DMBS may not appropriately be recommended at this time, as a generic type we recommend a relational database system that has flexibility for facile updating of individual items (parameter values) associated with any record. In addition, the DBMS should be flexible enough to accommodate changes in protocols (reporting, data validation, increased numbers of parameters) without extensive redesign of the software. A DBMS such as Model 204 - that which the CAPMoN data utilizes, is powerful and flexible (though expensive to operate), and is compatible with existing hardware accessible to RMD and may be considered. However, a more detailed selection process should be conducted.

3. NETWORK QUALITY ASSURANCE/QUALITY CONTROL

This chapter presents the assessment of the operational aspects of the AOSERP network according to objective quality assurance and quality control (QA/QC) criteria. These criteria attempt to determine the confidence in network results by examining:

1. representativeness of sampling sites,
2. completeness of data recovery,
3. adherence to well defined siting criteria,
4. accuracy of results,
5. precision of results, and
6. comparability of results.

Each of these aspects is examined in turn for precipitation and snowpack sampling. The procedures used in the field and laboratory are compared to procedures currently used in other major North American networks established for obtaining similar types of environmental data. In each section (i.e., precipitation sampling, snowpack survey, and laboratory analysis), the best procedures currently available are presented first, and the corresponding practices used in the AOSERP network are evaluated subsequently through comparison with these procedures. Inconsistencies in the procedures that may lead to difficulties in achieving the stated objectives of the AOSERP network are discussed. Alternative techniques or procedures are suggested.

It is clear from the analysis of the network's operational procedures that many problems existed. These were related to logistical constraints because of the remoteness of the study region and to a lack of resources for support of network activities using state-of-the-art procedures and instrumentation. Nonetheless, the network has stated objectives and the procedures employed must be judged with reference to the objectives. Deviations from the best available protocols must be critically assessed to determine their impact in terms of data quality and integrity and achievement of the network's objectives. After performing this critical review of procedures, the AOSERP environmental program management will be in a position to evaluate whether its objectives require reformulation or whether upgrading of the network is required.

It is important to define the terminology used in this chapter to clarify the terms of reference established for the evaluation procedures.

1. Representativeness refers to the distribution of sites with respect to diverse regions known to exist in the study area. Sites should be distributed to ensure coverage of different areas of local topography (e.g., hills, valleys), types of vegetative cover, soil types, and climatic regions.
2. Completeness refers to the degree to which the network (with existing procedures) provides reliable data for estimation of the parameters of interest. Incomplete data recovery may result from non-representative siting, poor siting (i.e., not following criteria), improper procedures, instrumentation malfunctions in sampling and analytical procedures, and/or human error in any of the tasks required to obtain a sample.
3. Siting criteria refer to the set of rules established to ensure that samples from each site are obtained with minimum influence from the site and with as few sources of bias as possible. It is almost impossible to obtain ideal sites for each location in the network, therefore codes are usually attached to data from specific sites to ensure that data users are aware that characteristics for these specific sites are not ideal.
4. Accuracy is defined as the degree of agreement of a measured value with an accepted reference or true value (U.S. EPA 1976). Field accuracy is usually monitored through the analysis of field blank samples and standard samples subjected to the same handling, transportation, and analytical procedures as precipitation or snow samples. A second aspect of accuracy particularly relevant to precipitation samples is the efficiency of the collector, which is assessed by comparing it with a co-located standard rain

gauge. For snow samples, accuracy is assessed by comparison with a Nipher snow gauge.

5. Precision is defined as the mutual agreement among individual measurements of the sample property (U.S. EPA, 1976). The level of imprecision results from sampling variability, and can be caused by variability in sampler efficiency; operator introduced inconsistencies, sample storage effects, and analytical variability. Analysis of samples obtained from co-located sites, split samples, and analytical replicates provides statistical estimates of precision for each component in the measurement process.
6. Comparability is a measure of the confidence with which a data set can be compared to another (U.S. EPA, 1976). Network procedures designed to meet this objective include the use of standardized units, reporting of quality assurance data such as collector efficiencies, anion/cation ratios, precision and accuracy estimates, data confidence limits, the documentation of results with suitable codes, and participation in both field and laboratory intercomparisons.

The elements defined here form the components of a quality assurance/quality control scheme. The implementation of specific controls to address these elements will lead to improved data quality, and will permit the statistical definition of the level of confidence in the network results. This chapter discusses the quality assurance and quality control currently used in the operation of the AOSERP network with respect to each of these aspects. In Section 3.1 the precipitation network is evaluated, in Section 3.2 the snowpack sampling surveys are discussed, and in Section 3.3 laboratory methods and procedures are examined. A summary of the overall evaluation and recommendations is provided in Section 3.4. This summary can form the basis for the establishment of a formalized quality assurance plan for the AOSERP network.

### 3.1 EVALUATION OF THE AOSERP PRECIPITATION NETWORK

In 1976, studies of the chemistry of rain and snow were initiated in the Athabasca Oil Sands area of northeastern Alberta by Alberta Environment and the Atmospheric Environment Services of Environment Canada. These studies involved the collection and chemical analysis of event rain and bulk snow samples. A summary of AOSERP network operations is provided in Table 9, and a map displaying the location of the precipitation event sampling sites is provided in Figure 3.

#### 3.1.1 Specific Network Objectives

The objectives of the AOSERP summer network throughout the years of operation (1976 to 1979, 1981 to 1984) are summarized below:

1976 to 1979 - The main objectives were to:

- determine changes in the deposition rate of atmospheric constituents
- provide a database for the documentation of variations in the chemical characteristics of precipitation (Olson et al., 1982b)

1981, 1982, 1984 - The main objectives were to:

- determine changes in the deposition rate of atmospheric constituents
- provide a database for the documentation of variations in the chemical characteristics of precipitation (Olson et al., 1982b)
- monitor the level of background pollutants in northeastern Alberta
- study and measure effects of point source emissions on wet deposition (Peters, 1981)

1983 - The objective of this study was to identify the probable sources and magnitude of errors during the collection, storage, and analytical procedures employed for the 1981 and 1982 studies.

Table 9. AOSERP precipitation monitoring network operation summary.

Site	Location Lat.	Long.	Elevation (m a.s.l.)	1976	1977	1978	1979	1980	1981	1982	1983	1984
Birch Mtn. Lookout	57° 43'	111° 51'	850	E	S,F,E	E	E	N/O	E	E	N/O	E
Bitumount Lookout	57° 22'	111° 32'	350	E	E	E	E	N/O	E	E	N/O	E
Buckton Lookout	57° 52'	112° 06'	790	E	E	E	E	N/O	E		N/O	E
Edra Lookout	57° 51'	113° 15'	790		E			N/O			N/O	E
Ells Lookout	57° 07'	112° 21'	560	E	E	E	E	N/O	E	E	N/O	E
Gordon Lake Lookout	56° 37'	110° 30'	490	E	E	E	E	N/O	E		N/O	E
Grande Lookout	56° 18'	112° 13'	530					N/O	E	E	N/O	E
Jean Lake Lookout	57° 30'	113° 53'	700	E	E	E	E	N/O			N/O	
Johnson Lake Lookout	57° 35'	110° 20'	550	E	E	E	E	N/O	E	E	N/O	E
Keane Creek Lookout	58° 19'	110° 17'	460	E	E	E	E	N/O	E	E	N/O	E
Legend Lookout	57° 27'	112° 53'	850	E	E	E	E	N/O	E	E	N/O	E
Mildred Lake	57° 05'	111° 35'	310	E	S,F,E	E	E	N/O	E	E	N/O	E
Muskeg Mtn. Lookout	57° 08'	110° 54'	550	E	E	E	E	N/O	E	E	N/O	E
Richardson Lookout	57° 53'	111° 02'	300	E	S,F,E	E	E	N/O	E		N/O	E
Steepbank River	56° 59'	111° 22'	270		S,F,			N/O			N/O	
Stony Mtn. Lookout	56° 23'	111° 14'	760	E	E	E	E	N/O	E	E	N/O	E
Thickwood Hills Lookout	56° 47'	111° 45'	520	E	E	E	E	N/O	E	E	N/O	E
Sandalta Lookout	57° 11'	111° 25'						N/O			E*	E

E - Event only  
E\* - Special study

S - Monthly bulk Sacramento  
N/O - Network not operating

F - Monthly wet only Finnish

1976 to 1977 - Polyethylene cylinder

1978 to 1979 - Polyethylene container and funnel

1981 to 1984 - 100 L polyethylene container and lid with plastic bag insert

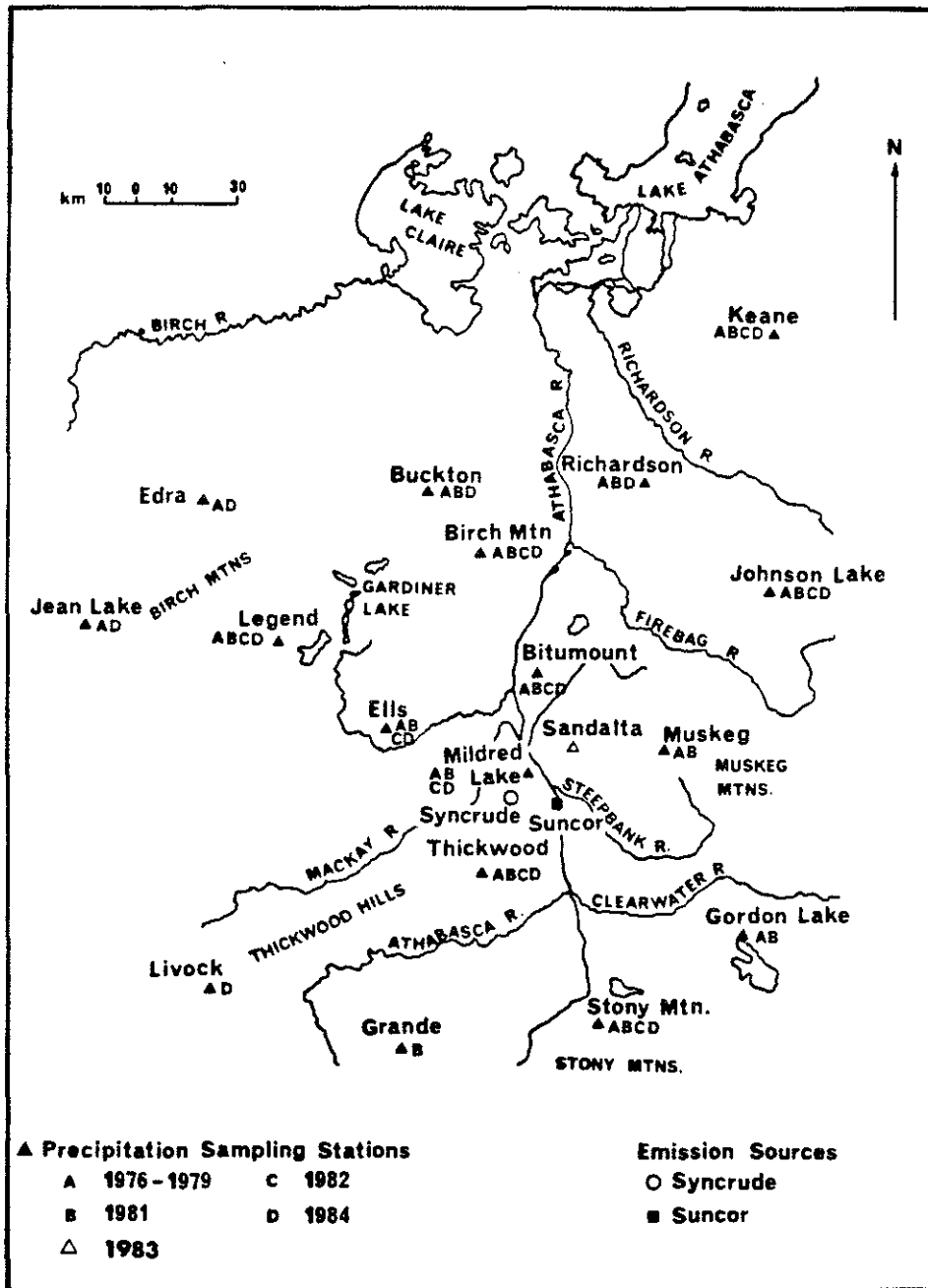

Figure 3. AOSERP summer sampling sites.



### 3.1.2 Site Selection Criteria and Evaluation

There are many factors that affect the selection of a site for locating precipitation chemistry samples. The critical factors for meeting network objectives include:

- location of sites for monitoring of pollutants of interest from the target sources; and
- prevention of contamination by local sources other than those being monitored.

Proper siting is critical to the success of the network. That is, if a site is poor, then low quality and non-representative data will result regardless of the quality of network operations and instrumentation.

The siting criteria utilized when choosing AOSERP sites were derived from the Ontario Ministry of the Environment Acidic Precipitation in Ontario Study (APIOS) network, which in turn were based on the Long Range Transport of Air Pollutants (LRTAP) task force recommendations (Olson et al., 1982b). These modified criteria are listed in Table 10. It should be noted that the APIOS network criteria were based on monitoring LRTAP, hence the inclusion of the criterion excluding sites within 50 km of point sources. The application of APIOS criteria *carte blanche* to the AOSERP network is therefore inappropriate.

The AOSERP sites, for the most part, are representative in the sense that they are isolated, radially distributed with respect to the two emission sources of interest, Suncor and Syncrude, and manned during the project year. There are no other large anthropogenic sources present in the region. The topography of the area is characterized by gradual to steeply sloping hills that are separated by broad lowlands. The vegetation and soils of the study area are characteristic of the boreal forest region of northern Canada. Boreal forest is a mosaic of aspen, pine, and white spruce stands interspersed with willow and black spruce. Luvisolic, Brunisolic, and Organic soils are dominant in the region (Olson, 1982). The AOSERP sites are located in highlands and lowlands representative of the regional topography. In order to assess the representativeness of

Table 10. Siting criteria.<sup>a</sup>

1. There should be no continuous sources of anthropogenic emissions within 50 km of the site.
2. There should be minimal sources of pollution or wind-activated sources within 1 km of the site (e.g., runways, roads, sewage plants, fuel depots, salt piles, exposed soil, landfill sites).
3. The sampler should be located on good ground cover, preferably grass, and annual vegetation within the site should be maintained at less than 0.61 m in height.
4. The sampler should be located two to three heights (300 m) away from the nearest windbreak (i.e., tree, building, or other obstacle).
5. The site must be easily accessible to an operator.
6. There must be an operator on site to collect samples when required. The position of the operator is important, and must be such that the sampler can be seen clearly.

<sup>a</sup> Adapted from Bardswick (1983).

the network on a regional basis, information on the relative quantity and type of soil and vegetation in the area is required.

It is often difficult to eliminate local sources of sample contamination. There is generally a trade off between those factors that influence the sample integrity and those that affect the logistics and operations of samplers. Factors affecting the chemical integrity of precipitation samples at the forest fire lookout sites in the AOSERP network include:

- trees - through fall, splash, organic debris
- buildings - splash, emissions
- overhead wires - splash
- ground cover - dry deposited windblown contaminants
- surrounding topography - windswept ridges, eddy zones
- air or ground traffic - emissions, dry deposited wind-blown contaminants

An attempt was made to qualitatively assess the AOSERP sites in relation to site specific characteristics using the siting information available. This information was limited to site diagrams (Figures 47 to 60 in Section 8.2), topographical maps, some photographs of meteorological stations at these sites (outdated), and personal communication with AOSERP personnel. After reviewing the information provided, a complete qualitative assessment of the sites was impossible because of the following:

1. Site documentation containing specific siting information (i.e., obstructions, type of windbreak, relative heights and distances of objects to sampler, specific ground cover and slope, local influences, etc.) was lacking.
2. Site drawings were incomplete. Critical information missing includes type of ground cover and relative heights and distances.
3. Site drawings were not to scale.
4. Site drawings were outdated or not available for

certain sites (e.g., Edra Lookout, Jean Lake Lookout, Livock Lookout, and Sandalta).

A partial evaluation of the AOSERP sites with respect to the stipulated siting criteria was carried out and is summarized below:

1. Twelve of the 18 AOSERP sites are at least 50 km from the Syncrude and Suncor plants. The sites that are less than 50 km from the point sources and their approximate distance from the mid-point of these two sources are: Mildred Lake, 10 km; Sandalta, 25 km; Thickwood, 25 km; Muskeg, 40 km; Bitumount, 45 km; and Ells, 48 km. These sites would be specifically designed to meet the second stated objective of the network, namely to "study and measure the effects of point source emissions on wet deposition" (Peters, 1981). The declaration of the use of APIOS siting criteria for the AOSERP network therefore, does not accurately reflect all the network objectives.
2. Potential sources of contamination at all AOSERP sites include emissions from small aircraft or helicopters and generators on site. In order to assess and quantify their influence on the samples, information such as size, type, frequency of use, and expected emissions is required. Overhead wires from the towers also may affect sample integrity if they are located near the samplers. At the Mildred Lake site, there is a refuse dump within 40 m south of the site.
3. Ground cover at most of the sites is unknown. This is an important factor in site assessment. If the ground cover is loose soil or sand, samples may be contaminated by windblown dust. This is especially true at sites that are close to helicopter pads or runways.
4. The heights of buildings, towers, trees, and other obstacles are not specified in all site drawings. Sites in which tree heights have been specified and

that violate criterion 4 include: Buckton, Edra, Ells, Grande, Stony Mountain, and Thickwood Hills.

5. Tower personnel are usually on site throughout the duration of the program.
6. Most sites are located in forest clearings providing a good windbreak. Sites in which the windbreaks are in violation of criterion 4 have already been noted.

A standard site documentation package should be designed and completed for each site to ensure that site documentation is sufficient and complete for data users to assess the suitability of AOSERP sites. This documentation package should include the following information:

- description of on-site monitoring equipment
- recent photographs of site and instrumentation
- details of potential sources of contamination on a local and regional basis
- detailed description of ground cover and soil type on site and neighboring obstacles
- list of deviations from siting criteria and a summary of the advantages and disadvantages of the site
- a current site and operator evaluation based on standard guidelines (i.e., internal performance audit for operators and site auditors inspections)
- frequency of use of transportation routes (e.g., roads, landing strips, helicopter pads)

A suggested site documentation package is found in Section 8.3.

Availability of siting information and its evaluation with respect to the siting criteria are tabulated and summarized by site in Table 11 and Table 12. The information presented in these tables was obtained from site diagrams, topographical maps, photographs of some meteorological stations at these sites, and personal communication with Alberta Environment personnel.

Table 11. Summary of siting information available from site diagrams.

Site	Site Diagram	Height of Tower and Length of Guy Wire	Height of Buildings	Distance of Tower to Sampler	Distance of Buildings to Sampler	Distance of Trees to Sampler	Height of Trees/Brush	Density of Trees/Brush	Information on Generator Other than Location	Information on Air/Traffic
Birch Mtn. Lookout	YES	NO	NO	YES (9 m)	YES (18 m)	NO	Trees (6 m) Brush (no)	NO	NO	NO
Bitumount Lookout	YES	NO	NO	NO	NO	YES (15 m)	Trees (12 m) Brush (no)	NO	NO	NO
Buckton Lookout	YES	NO	NO	NO	YES (30 m)	YES (15 m)	Trees (15 m) Brush (no)	NO	NO	2 Helicopter Pads
Edra Lookout	NO									
Ells Lookout	YES	NO	NO	YES (12 m)	NO	YES (12 m)	Trees (22 m) Brush (low)	NO	NO	NO
Gordon Lake Lookout	YES	NO	NO	NO	YES (12 m)	YES (30 m S) (9 m W)	Trees (12 m)	NO	NO	Airstrip
Grande Lookout	YES	NO	NO	NO	YES (30 m)	YES (18 m)	Trees (24 m)	NO	NO	NO
Jean Lake Lookout	NO									
Johnson Lake Lookout	YES	NO	NO	YES (43 m)	YES (34 m)	YES (23 m E) (12 m S)	Trees (10 m) Brush (no)	NO	NO	Airstrip
Keane Creek Lookout	YES	NO	NO	NO	YES (22 m)	NO	Trees (3 m) (5 m)	NO	10 m W	NO
Legend Lookout	YES	NO	NO	NO	YES (30 m)	YES (18 m)	NO Scrub low	NO	NO	NO
Mildred Lake	YES	N/A	N/A	N/A	N/A	NO	Trees (10 m)	NO	N/A	Helicopter Pad
Muskeg Mtn. Lookout	YES	YES (30 m)	NO	YES (25 m)	YES (20 m)	YES (15 m)	NO- "Low Trees"	NO	Engine house 11 m W	Airstrip 70 m E
Richardson Lookout	YES	NO	NO	YES (5 m S)	YES (12 m E)	NO	"Short Brush Trees" 12 m	NO	NO	Helicopter Pad
Steepbank River	NO									
Stony Mtn. Lookout	YES	NO	NO	NO	YES (18 m)	YES (12 m N) (18 m E)	Trees (7 m) (12 m)	NO	NO	Road NE
Thickwood Hills Lookout	YES	NO	NO	YES (15 m)	YES (12 m)	YES (15 m W)	Trees (13 m)	NO	15 m N AGT 70 m E	Helicopter Pad
Sandalta Lookout	NO									
Livock Lookout	NO									

N/A - not applicable

Table 12. Summary of siting information available from photographs, slides, and site diagrams.

Site	Photographs/ Slides	Type of Ground Cover/ Slope	Information Obtained from Slides
Birch Mtn. Lookout	YES/YES	NO	<ul style="list-style-type: none"> <li>- poor ground cover (some loose soil)</li> <li>- strip surrounding site looks sandy</li> <li>- mixed forest surrounding area (deciduous and coniferous)</li> <li>- numerous overhead wires; proximity to sampler unknown</li> <li>- ground cover uncut weeds &amp; brush; tower too close 9 m S</li> </ul>
Bitumount Lookout	YES/YES	NO	<ul style="list-style-type: none"> <li>- cut straw like grass</li> <li>- ground cover, tall and dense row of coniferous and deciduous trees, N, S, and E of sampler; fewer deciduous trees west of sampler - all trees are within 2.5 heights of sampler 12 m tall, 15 m E</li> </ul>
Buckton Lookout	NO/NO	NO Hill nearby	<ul style="list-style-type: none"> <li>- proximity of helicopter pads to sampler is of some concern</li> <li>- trees too close 15 m tall, 15 m N of sampler</li> </ul>
Edra Lookout	NO/NO		
Ells Lookout	YES/YES	NO	<ul style="list-style-type: none"> <li>- tall deciduous trees surrounding less than 2.5 tree heights from sampler, 22 m tall, 12 m W of sampler</li> </ul>
Gordon Lake Lookout	NO/NO	NO	
Grande Lookout	NO/NO	NO	<ul style="list-style-type: none"> <li>- trees less than 2.5 average tree heights, 24 m tall, 18 m W</li> </ul>
Jean Lake Lookout	NO/NO	NO	
Johnson Lake Lookout	NO/NO	NO	
Keane Creek Lookout	NO/NO	NO	
Legend Lookout	NO/NO	NO	<ul style="list-style-type: none"> <li>- outhouse and garden on site</li> </ul>
Mildred Lake	YES/YES	NO	<ul style="list-style-type: none"> <li>- refuse dump 40 m S of sampler</li> <li>- within 10 km of Syncrude</li> </ul>
Muskeg Mtn. Lookout	YES/YES	NO	<ul style="list-style-type: none"> <li>- large landing strip</li> <li>- good bank of trees between landing strip and sampler</li> <li>- ground cover is uncut weeds and rock</li> <li>- brush 2 m tall and very dense</li> <li>- 2 small propane tanks, 2 m from sampler</li> <li>- tower within 1 height</li> </ul>
Richardson Lookout	YES/YES	HILL	<ul style="list-style-type: none"> <li>- large landing strip</li> <li>- surrounded by burned forest</li> <li>- ground cover moss, rocks and sand</li> <li>- west of sampler is dense forest of deciduous trees</li> </ul>
Steepbank River	YES/NO	NO	<ul style="list-style-type: none"> <li>- very tall uncut weeds/haylike grass</li> <li>- same height as orifice of sampler</li> </ul>
Stony Mtn. Lookout	NO/YES	Steep slope E of site	<ul style="list-style-type: none"> <li>- ground cover is brush (tall) uncut weeds, rocks and some loose sand</li> </ul>
Thickwood Hills Lookout	YES/YES	NO	<ul style="list-style-type: none"> <li>- trees 13 m tall, 15 m W of sampler violates 2.5 heights criteria</li> <li>- ground cover tall uncut weeds or brush</li> </ul>
Sandalta Lookout	NO/NO	NO	
Livock Lookout	NO/NO	NO	

<sup>a</sup> Photographs and slides are of meteorological station at each site and not AUSERP instrument site.

### 3.1.3 Sample and Field Data Collection and Handling

The general objective of sample collection and handling procedures for precipitation samples is to ensure that sample integrity is maintained throughout all procedures including sample collection, handling, shipping, and storage. In order to achieve this objective the monitoring network must develop a detailed set of operating procedures designed to maintain sample quality and operational efficiency. Some key steps to ensure sample integrity are found in Section 8.4.

A series of precipitation chemistry procedures manuals that outline sample handling methods and instrumentation used is available for the AOSERP Network Studies of 1977, 1981, 1982, and 1984 (Nespliak, 1977; Peters, 1981; Olson, 1982; Blower, 1984). Sample handling and field data collection procedures are briefly described and evaluated in terms of sample quality for each of the study periods.

3.1.3.1 1976 to 1979. The event wet-only sampler used during this period consisted of a pointed metal rod to which a plastic cylinder (10 cm in diameter, 25 cm in length) was attached. During 1976 and 1977, a second cylindrical collection vessel (plastic Frig-0-Seal container) was inserted snugly into the first. A plastic pail was used to cover the collection vessel during dry periods. Samples were collected by removing the pail covering the sample collection vessel when rain started and then removing the sample when it stopped. Operators were instructed to store the pail in a manner that would avoid contamination. At the end of an event the sample was transferred to a 250 mL polyethylene bottle, labelled and stored in a refrigerator. At the end of the month the samples were picked up and sent to the laboratory.

During the 1978 and 1979 studies, the sample transfer step was eliminated by collecting the sample directly in the 250 mL polyethylene bottle. A funnel (approximately 15.3 cm in diameter) was used to channel the flow into the bottle. Samples were collected by removing the lid covering the funnel. The funnel was rinsed with



distilled water and a new bottle installed to receive the next sample. Samples were stored in a refrigerator and sent to the laboratory at the end of each month.

In 1980, the Research Management Division of Alberta Environment conducted an extensive review of the procedures and techniques being used in other precipitation chemistry networks. This resulted in the identification of potential inconsistencies in the 1976 to 1979 studies. Problem areas included sample collection and handling procedures, limitations of analytical techniques, and the unknown reliability of data without a quality assurance program. Weaknesses in sample handling and data collection procedures, which may have effected sample quality, are summarized below.

1. Operators were provided with an Information Sheet containing general rather than explicit sample handling procedures. This lack of explicit instructions may have led to misinterpretation of instructions and thus caused poor sample quality. Comments included "rain samples should be kept in a refrigerator"; "rain samplers should be installed in an exposed area that is convenient, preferably in an instrument area where other observations are carried out" and "samples should be taken at the beginning of each storm as best chemical 'washout' occurs at this time". The word "should" was used rather than must for key items such as set-up of precipitation samplers, refrigeration of samples, and beginning of sampling period. The information sheet did stress the importance of preventing physical contact with the sampling vessel. It did not, however, provide specific instructions for sample transfer from the collection vessel to the 250 mL polyethylene bottle. This is a critical step as the potential for sample contamination or loss due to spillage is great.
2. There was no formalized training for operators. Training programs are essential to ensure high quality

samples, especially when the operators are not provided with explicit sample handling procedures. The way in which operators handle the samples may vary from site to site within the network. Essential ingredients of a network design include a strict set of siting criteria and uniformity of sampling protocols, analytical techniques and procedures.

3. There were no field sheets for these studies other than a log at the Mildred Lake Research Facility containing the sample code, pH, and conductivity. Essential information required includes the beginning and end of a sampling period; the type of sample (e.g., rain, snow, dew); details of the event (e.g., thunderstorm, drizzle, showers, forest fire); the condition of the sample (e.g., presence of insects, leaves, particles); sample handling (spilled samples, lost sample, unusual procedures used); and sampler operation (e.g., malfunction, normal). Field observations are important in assessing site characteristics which may affect the quality of a parameter measured.
4. Sample collection vessels may have had an effect on sample integrity. Sample collection vessels and funnels were used more than once and had to be washed and rinsed between events. Contamination of the wet surface by dry deposition could have resulted from rinsing the funnel with distilled water in the field. An in-laboratory quality control on the cleaning procedure of the collection vessels detected residual contamination in one of the five vessels examined.
5. There was a long delay in getting samples from the sites to the Mildred Lake Research Facility, and then to the laboratory. Samples took up to a month to get to the Mildred Lake Facility. The long-term storage periods were not evaluated in terms of their effects on sample integrity.

3.1.3.2 1981, 1982, 1984. The sampler utilized for the 1981, 1982, and 1984 studies consisted of a 100 L polyethylene container (commonly used as a domestic refuse receptacle) with a tightly fitting lid to prevent dust and suspended particles from entering. Stakes held the sampler firmly to the ground. The samples were collected in a polyethylene bag which had a heat imprinted compartment within the bag to reduce evaporation losses and prevent contamination of the sample. Samples were collected by removing the lid of the sampler and exposing the sample bag to the precipitation. At the end of the sampling period the sample bag was removed and sealed using a wire twist tie (1981) or a heat sealer (1982, 1984). Samples were then placed in a black plastic bag and refrigerated until they were picked up, usually within nine to 11 days. When samples were in transit they were kept cool with ice (see Figure 4).

The collection of precipitation samples for the AOSERP network is a secondary responsibility of the forest fire observers. The recommended sampling procedures have been developed to minimize the inconvenience to the operator and maximize sample quality. The 1981 and 1982 studies collected daytime precipitation samples, and the 1984 study collected both daytime and night-time samples. Sampling procedures varied depending on whether or not operators were in the towers or on the ground at the time of the event. Sampling periods and sample handling procedures varied throughout the studies. Guidelines developed for the collection of samples are summarized in Table 13.

3.1.3.3 1982. If the operator was in the tower when the rain began to fall, the operator was to record the time and date on the tag and record sheet, and tug on the cord attached to the lid of the sampler to release the lid from the sampler. The lid is either pulled into the tower or suspended in the air to avoid contact with the ground and contamination of the lid.

If the operator was on the ground, the operator was to record the time and date on the tag and data sheet. The operator would then remove the lid from the sampler and take it indoors, placing it in a clean, dry area.

Table 13. Summary of sample handling procedures.

Sample Handling Procedure	Comments on Sample Quality
<p>1981</p> <ol style="list-style-type: none"> <li>1. If the rain event only lasts a short time, replace the lid as <u>soon as the event is over and take the sample.</u></li> <li>2. If the rain event is a long one, replace the lid when a maximum of 12 hours is reached and take the sample.</li> <li>3. If a rain event is taking place and you have already removed the lid and can no longer monitor the situation (e.g., going to sleep, going away from station), replace the lid and take the sample.</li> </ol>	<p>1981</p> <ol style="list-style-type: none"> <li>1. Ideal situation - wet-only sample.</li> <li>2. Only a partial event is sampled. Wet-only sample; no night-time sampling.</li> <li>3. Only a partial event is sampled. No night-time sample; bias sampling.</li> </ol>
<p>1982</p> <ol style="list-style-type: none"> <li>1. If the rain event only lasts a short time, remove the sample as soon as the event is over or once you come down from the tower.</li> <li>2. If the rain event is a long one, replace the lid when a maximum of 12 hours is reached and remove the sample.</li> <li>3. If a rain event is still taking place but you can no longer monitor the event (e.g., going to sleep or leaving the tower area), then take the sample instead of leaving sampler open for extended periods.</li> </ol>	<p>1982</p> <ol style="list-style-type: none"> <li>1. If operator does not come down from tower for an extended period of time, there is a potential of contaminating the sample (dry deposition). Bulk sampling rather than wet-only.</li> <li>2. Only partial event collected; wet-only sample.</li> <li>3. Only a partial event is sampled. No night-time sample bias sampling.</li> </ol>

continued...

Table 13. Concluded.

Sample Handling Procedure	Comments on Sample Quality
<p>1984</p> <ol style="list-style-type: none"> <li>1. If it has been raining for a significant period of time before you go to bed, collect the sample and complete the field log and sample sheet. Immediately place another sample bag in the collector, being careful not to contaminate the sample by dripping water from your hands or clothes into the sample. Start a second sample sheet and record on a separate line in the field log. Collect this second bag the next morning and complete the sample sheet and field log.</li> <li>2. If it has only recently started raining and it appears that rain will continue for some time, leave the existing sample bag in place until the following morning when it stops raining.</li> <li>3. If it is not raining when you go to bed, open the sampler and leave it open all night. If rain is present in the bag in the morning, collect the sample and complete the field log and sample sheet. Give estimates of rain start and stop times, if possible, or use NOT AVAILABLE (N/A). If no rain has been collected during the night, replace the bag with a clean one and replace the lid after it has been thoroughly cleaned on the inside with Kimwipes.</li> </ol>	<p>1984</p> <ol style="list-style-type: none"> <li>1a Avoids overflow of sample. If rain stops shortly after operator goes to bed, the initial sample is a wet-only and not bulk.</li> <li>1b Prevents first sample from sources of contamination via dry deposition.</li> <li>1c Second sample is bulk sample.</li> <li>2. Complete event sampled - may be a period of bulk sampling if it stops raining in the middle of the night.</li> <li>3. Bulk sampling only.</li> </ol>

3.1.3.4 1984. If the operator was in the tower when the rain began, the operator was to record the time and date on the field log and data sheet, then tug on the cord to release the lid from the sampler. The lid was then suspended in the air against a tripod. If the operator was on the ground, the operator was to record the time and date on the field log and on the data sheet, remove the lid of the sampler, and secure it against the tripod. If the rain event lasted only a short time, the sample was to be collected as soon as the event ended, or as soon as the operator came down from the tower.

An evaluation of the sample collection procedures and instrumentation in terms of sample quality follows.

1. Operators were provided with a procedures manual and attended a training session with Alberta Environment personnel prior to the commencement of the study. These procedures manuals were explicit in describing methods for inserting and removing sample bags. As the network evolved from 1981 to 1984, these manuals expanded to contain more detail. Not only did they describe sample handling procedures, but they also provided the operator with information such as:
  - a listing of equipment and supplies (in 1984 the manual also contained an explanation of the purpose of each)
  - a description of potential sources of contamination
  - instructions regarding maintenance of sample integrity
  - sample pick-up schedules
  - field data sheets
  - overview of the network and its objectives

The 1984 manual also contained routine maintenance procedures and trouble-shooting for sampling problems. Information not contained in the manuals, which should be incorporated, includes sample handling procedure for QC field samples.

2. Wire tags used for sealing sample bags in 1981

- increased the chance of contamination from dry deposition and leakage of sample. To minimize these problems, sample bags were heat sealed in 1982 and 1984.
3. To maintain sample integrity, all samples were either refrigerated or kept in coolers with ice packs. The temperature of the coolers containing the samples was monitored by the operators and an upper limit of 8°C was set. Operators were provided with six ice packs to be used on a rotational basis, three in the cooler and three in the freezer. The temperature of the cooler was recorded on the rain field log sheet.
  4. A lid was used to cover the sampler bag during dry periods to prevent suspended particles from entering and contaminating the collection vessel. The lid itself was a potential source of contamination since dust and dirt deposited on the inside of the lid might be transferred to the sample bag. Proper cleaning and handling of the lid was essential. Plastic disposable gloves were to be worn when handling the lid, especially the inside or the edges, since these come in contact with the sampling bag. The lid was to be cleaned using deionized distilled water and Kimwipes. During precipitation events, the lid was to be removed and stored in a clean dry place.
  5. To obtain comparability within network sites, uniformity in sample handling and collection procedures is essential. Table 13 summarizes the sample handling procedures utilized for the 1981, 1982, and 1984 studies and effects of those procedures on sample quality. Manual sampling was totally dependent on the site operators. The beginning portion of an event may have been missed if an operator was not able to remove the sampler lid. Because precipitation composition can vary significantly within and between events, every effort should be made to collect the entire

portion of all events at each station. Bulk sampling will result if an operator is unable, or forgets, to remove the sample at the end of an event. Exposure time of the sample to ambient air should be kept to an absolute minimum. Bulk sampling imposes severe limits upon the data due to the chemical influences of dry fallout on the chemistry of rain within the collector (Galloway and Likens, 1978). A special study completed by the Ontario Ministry of the Environment APIOS network, comparing Aerochem Metrics wet-only samplers and SES bulk collectors (similar to AOSERP collectors with plastic bag inserts), has shown an elevation of certain chemical species, namely sulphates, nitrates, calcium, ammonia, and pH, in bulk samplers. Soil derived contamination was suspected to be the cause of the elevated concentrations. (Bardswick, W.S., personal communication, 1985).

6. Table 14 summarizes the various types of precipitation collectors utilized by the AOSERP network and evaluates each in terms of sample quality. The various wet-only samplers are shown in Figure 4.

An evaluation of the precipitation collection network would be incomplete without reference to the instrumentation employed for sampling. The currently used technique makes use of manual exposure of a collector during precipitation events. Several major problems are identifiable because of the requirement for manual operation of the collector. First, the use of on-site operators can lead to inconsistent operation because of variability in timing response (i.e., operators do not or may not be able to respond consistently). Second, the current sampling practices lead to missed portions of events, which in turn make data interpretation very difficult. For example, if the initial portion of the event is missed, a significant underestimate of the chemical element loading can result. This is a consequence of the high concentrations usually observed in the first part of rain events (Easter, 1984). Additional variability is intro-



Table 14. AOSERP summer precipitation sampling instrumentation.

Year	Precipitation Sampling Instrumentation	Comments
1976, 1977	<p>Event wet-only sampler used at 15 sites. Consisted of a pointed metal rod (1 m tall) to which a 10 cm (diameter) x 25 cm plastic cylinder was attached. A second cylinder (sample collection vessel) fit snugly into the first. A plastic lid was used to cover the tops of both cylinders.</p>	<ul style="list-style-type: none"> <li>- Events of at least 10 mm were required to obtain sufficient volume for the chemical analysis. If the precipitation events deposited less than this, the sample would be rejected.</li> <li>- The sample collection vessel had to be meticulously washed and rinsed with laboratory detergent and distilled water. This introduced a large potential for contamination.</li> <li>- The timing of the removal of the lid was not standardized among the operators.</li> <li>- Sampler heights were not standardized.</li> </ul>
1978, 1979	<p>Event wet-only sampler used at 15 sites.</p> <p>Consisted of a pointed metal rod to which a 10 cm (diameter) x 25 cm plastic cylinder was attached. Instead of collecting the sample in a plastic cylinder, the precipitation was directed into a 250 mL polyethylene bottle. A plastic funnel was used to channel the flow into the bottle.</p>	<ul style="list-style-type: none"> <li>- The funnel needed to be cleaned between uses and the possibility existed that it could be contaminated.</li> <li>- Same as 1976, 1977.</li> </ul>

continued....

Table 14. Continued.

Year	Precipitation Sampling Instrumentation	Comments
1976	<p>Monthly bulk wet-only.</p> <p>An automated Finnish collector was used, consisting of a sensor that activated a movable hood, thus exposing a collection vessel. The collection vessel was a bucket with a plastic bag inside.</p>	<ul style="list-style-type: none"> <li>- Problems developed with the seal between the top of the collection vessel and the underside of the hood.</li> <li>- Poor seal could lead to loss due to evaporation and contamination entering the vessel.</li> <li>- AC electrical source was required to power the sampler.</li> </ul>
1976	<p>Monthly bulk - wet and dry.</p> <p>A modified Sacramento storage rain gauge with a polyethylene bag served as the collection vessel. The bag was constricted near its top to reduce evaporation and prevent relatively large objects from entering the vessel.</p>	<ul style="list-style-type: none"> <li>- Sample size was often inadequate. Information was also limited (Galloway and Likens, 1978).</li> <li>- Large potential for contamination.</li> </ul>

continued...

Table 14. Concluded.

Year	Precipitation Sampling Instrumentation	Comments
1981, 1982, 1984	Event wet-only - 100 L polyethylene container with a tight fitting lid was used. A polyethylene bag (modified - diagonal seam) was used as a collection vessel.	<ul style="list-style-type: none"> <li>- Bulk sampling resulted if operator did not replace the lid or collect the sample immediately following an event.</li> <li>- Manual operation - dependent on operator, therefore sampling period could vary from site to site and the entire event was not always collected.</li> <li>- Lid was a potential source of contamination.</li> <li>- Instrument was not comparable to other monitoring networks such as APIOS, CAPMoN, NADP, MAP3S (i.e., Modified Sangamo type A collectors, and/or Aerochem Metric sampler).</li> <li>- Sample bag could bunch at the orifice of the sampler, resulting in "splash out" of sample. Bag must be smooth to the orifice of the sampler (i.e., large orifice) in order to maximize the collection efficiency.</li> </ul>

1976, 1977

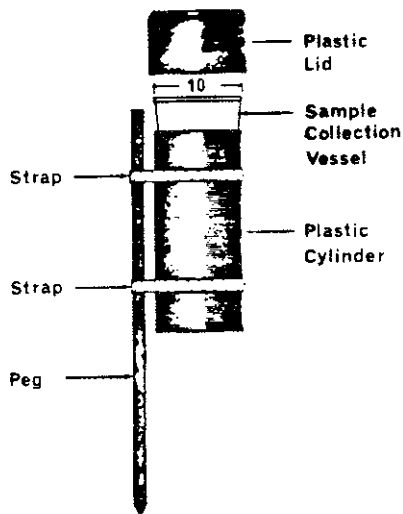

1978, 1979

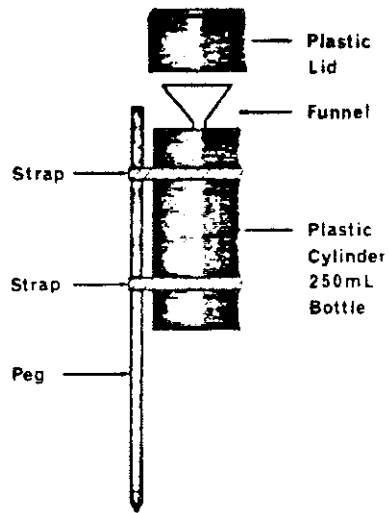

1981 to 1984

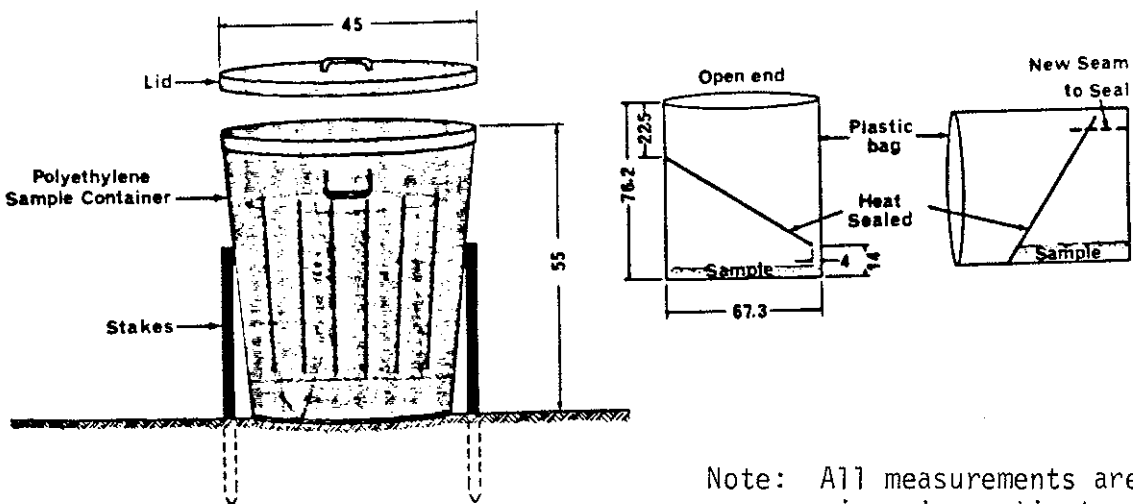

Note: All measurements are given in centimetres.

Figure 4. AOSERP precipitation collectors.

duced by inconsistent sample exposure times before removal from the open collector. In addition, because of a lack of ancillary equipment at each site, such as the standard rain gauge, it is not possible to determine if events have been missed entirely, nor can the actual efficiency of collection of precipitation during the collection period be determined. The utilization of automatic sampling equipment at AOSERP sites and the deployment of standard rain gauges at each of these sites would resolve these difficulties (CSC 1981, 1982; Galloway and Likens, 1976). The use of the manual collection method will continue to lead to difficulties in data interpretation and assessment, and will lead to an inability to define accuracy and precision of measurement.

#### 3.1.4 Precipitation Field Quality Assurance/Quality Control

The various types of QA/QC field samples are summarized in Table 15. This table lists the sample type, description, and the QA parameter measured during the AOSERP summer precipitation studies (1983 excluded). Given the level of QA/QC, the only QA check that can be carried out on the data is performing an ion balance. There is little QA information from the AOSERP precipitation studies (1976 to 1982) to assess the data in terms of accuracy and precision. As a consequence, it is difficult to quantify the confidence level of the data.

In 1983, a controlled field experiment was undertaken to identify probable sources and magnitude of errors that may have originated in either the collection, storage, or analytical procedures used in 1981 and 1982. This study used six pairs of precipitation collectors installed at the Sandalta air quality trailer site. Five pairs of the samplers collected event wet-only samples and one pair collected dryfall samples over a 10-day period.

The potential sources of error assessed include:

1. entrainment,
2. dead volume,
3. field storage temperatures,



4. sample exposure to ambient air and intrusion of coarse particles, and
5. effect of filtering the sample with respect to chemical integrity.

To obtain a measure of laboratory bias, one of the pair of samples was analysed at the Alberta Environmental Centre (AEC), while the other was analysed at the Kananaskis Centre for Environmental Research (KAN).

Table 16 summarizes the field quality control samples collected during this study. In addition to these QC samples, blank samples also were submitted to both laboratories at least once every 10 days. The blanks consisted of:

1. Deionized (DI) water blanks from the carboy at the Mildred Lake laboratory. DI water was poured into 50, 100 and 250 mL bottles capped with 2.5 cm of dead air space and stored at 4°C until shipped;
2. Bag blanks - DI water was added to four bags, sealed, and stored at 4°C for 24 hours. One pair was filtered and stored in a 100 mL bottle. The second pair was decanted into a 100 mL bottle and stored at 4°C;
3. Two unused clean sample bags from the Sandalta site were sealed 7.5 cm from the top and stored at 4°C until shipped.

If a large volume event occurred, a split sample was to be submitted for duplicate analysis. The filtration apparatus and graduate cylinder used at the Mildred Lake site were cleaned once a month by soaking in HCl, then in DI water, and rinsing three times with DI water.

It should be noted that since there were only six events collected during the 1983 study, only a very limited amount of data was available for statistical purposes. The field log from this study is presented in Table 17.

Our independent assessment of the 1983 QA/QC special study identified several aspects that were similar to those identified by Blower (Blower, 1984b). Recommendations arising specifically as a

Table 16. 1983 field quality control samples.

Sample Type and Number	Sampler Configuration	Sandalta Field Handling Procedure	Mildred Lake Lab Procedures	Analytical Lab
Control (5100, 6100)	<ul style="list-style-type: none"> <li>Control sampler positioned on ground</li> </ul>	<ul style="list-style-type: none"> <li>After each event of minimum of 200 mL, sample bag is removed, sealed, and stored at 4°C</li> </ul>	<ul style="list-style-type: none"> <li>Sample bag is removed from cooler and weighed</li> <li>Bag is opened and approx. 1/2 of sample is filtered into a bottle ensuring a minimum of 2.5 cm air space. Bottle is capped, labelled, and stored in cooler at 4°C (5100 F)</li> <li>Remaining half is poured directly into a bottle (same size as filtered sample), labelled, and stored at 4°C (5100 U)</li> </ul>	5100 - KAN 6100 - AEC F = filtered U = unfiltered
Entrainment (5200, 6200)	<ul style="list-style-type: none"> <li>Sampler is secured to a 1.2 m stand</li> </ul>	<ul style="list-style-type: none"> <li>Same as control</li> </ul>	<ul style="list-style-type: none"> <li>Same as control</li> </ul>	5200 - KAN 6200 - AEC
Dead Volume (5300, 6300)	<ul style="list-style-type: none"> <li>Sampler is secured to a 1.2 m stand</li> </ul>	<ul style="list-style-type: none"> <li>Same as control</li> </ul>	<ul style="list-style-type: none"> <li>Same as control except sample is stored in a bottle such that dead volume is eliminated</li> </ul>	5300 - KAN 6300 - AEC
Storage Temp. (5400, 6400)	<ul style="list-style-type: none"> <li>Sampler is secured to a 1.2 m stand</li> </ul>	<ul style="list-style-type: none"> <li>Same as control except sample is placed in garbage bag and stored at ambient temperature</li> </ul>	<ul style="list-style-type: none"> <li>Same as control except sample bottles are placed in green garbage bag and stored at ambient temperature</li> </ul>	5400 - KAN 6400 - AEC
Exposure (5500, 6500)	<ul style="list-style-type: none"> <li>Sampler is secured to a 1.2 m stand</li> </ul>	<ul style="list-style-type: none"> <li>After each event a covering mechanism is placed above sampler exposing sample to ambient air &amp; intrusion of coarse particles. Prior to next event or next day sample is removed, sealed, and stored at 4°C</li> </ul>	<ul style="list-style-type: none"> <li>Same as control</li> </ul>	5500 - KAN 6500 - AEC
Dryfall Collection (7100)	<ul style="list-style-type: none"> <li>Sample is secured on 1.2 m stand</li> </ul>	<ul style="list-style-type: none"> <li>Lids are securely placed on sampler during events and when technician is not on site</li> </ul>		7100, 7200 - AEC
(7200)	<ul style="list-style-type: none"> <li>Sampler is positioned on ground</li> </ul>	<ul style="list-style-type: none"> <li>Lids are removed during dry episodes</li> <li>Bag is replaced approximately once every 10 days to coincide with shipment of wet samples</li> <li>Sample bags are removed, sealed 7.5 cm from top, folded for shipping, and stored at 4°C</li> </ul>		



Table 17. 1983 rain project field log.

Sample Number	Time/Date Collected	Start Time	End Time	Bulk Rain Depth (mm)	Comments
01	10:12/July 9	16:00/July 8	10:01/July 9	13.7	Intermittent rain all day. Since rain started 17:30, samplers left open all night, collected the following morning, July 9.
02	18:00/July 14	15:05/July 14	17:40/July 14	1.5	Light showers.
	missed	14:00/July 24	14:30/July 24	3.2	Missed event, installing reversing arm plate on the tower. Thunderstorm.
03	13:55/July 26	13:35/July 26	13:50/July 26	8.0	Thunderstorm.
	missed	15:00/July 26	09:00/July 28	27.0	Rain all day on July 27, missed event since site was fogged in, could not fly to site.
04	14:10/Aug 17	08:15/Aug 17	13:15/Aug 17	1.1	Intermittent, light rain all day.
05	12:02/Aug 22	08:00/Aug 22	11:50/Aug 22	3.8	Rain event in progress when arrived on site. Intermittent rain most of the day.
06	16:40/Aug 26	16:25/Aug 26	16:35/Aug 26	5.8	Rainstorm.
	missed	11:25/Sep 10	11:40/Sep 10	1.1	Missed most of the event since I was in tent and was unaware of the sudden rain.

result of the data analysis Blower performed, and those from a general understanding of problems associated with precipitation chemistry studies are presented below.

1. Significant difference in results from the two labs for  $\text{NH}_4^+$ ,  $\text{Ca}^{2+}$ ,  $\text{Na}^+$  and conductance should be determined by doing more field and laboratory checks.
2. Stands should be used to raise collectors to a 2 m height above ground.
3. No samples should be filtered in the field without a thorough check of procedures and routine checks of filter contamination.
4. Exposure time of the sample to ambient air should be kept to an absolute minimum.
5. All samples should be stored in polyethylene bottles with a minimum dead air volume immediately after collection.
6. All samples should be stored at 4°C immediately after bottling.
7. Sample storage time before analysis should be kept to a minimum.
8. Both ion and conductance ratios should be calculated and used to determine acceptable results. Ratio values of 0.3 should be considered a (minimum) tolerable level and 0.2 a (minimum) desirable level for both ratio types. These tests should be performed by the laboratory and used as a guide for re-analysis of samples.
9. An improved field and/or laboratory procedure for the analysis of bicarbonate in the expected pH range of 3.5 to 7.5 should be found and used.
10. The remainder of the chemical and meteorological data acquired in 1983 needs to be added to the computer data files.

11. Additional statistical analysis of the data should be performed including:
  - a. plotting all AEC unfiltered vs. AEC filtered samples for all variables
  - b. plotting all KAN unfiltered vs. KAN filtered samples for all variables
  - c. manually checking all difference calculations used in the t-test for paired data to ensure missing values were handled as expected
  - d. recalculating the multivariant analyses printing the partial correlation matrix of treatment vs. all other variables

(Recommendation 11 was performed and reported in Yurko, 1984.)

General Recommendations:

1. Quality control checks of both field and laboratory procedures should be increased (typically 10 to 15% of samples are QA/QC samples in most major networks). Examples of field and laboratory QA/QC samples include:
  - a. blind primary standards should be included periodically in sample shipments to the laboratory
  - b. duplicate samples should be collected at a minimum of one station (likely Sandalta)
  - c. occasionally, duplicate (or split) samples should be sent to two additional laboratories for ion analysis
  - d. deionized water of known quality should be sent by the laboratory into the field to use as blanks. The unused water must be sent back to the laboratory in its original container for re-analysis
  - e. fifty mL of sample should be archived for at least one year to use for re-analysis if required (presently being carried out)
2. Other types of precipitation collectors should be tested and monitored at Sandalta along with the duplicate collectors already discussed. These could

- include two Sangamo collectors and possibly a state-of-the-art sequential sampler.
3. Organic acid values should be measured at several sites. Unfortunately, the treated sample retention time is only a few hours, so results would likely be only qualitative (presently being carried out).
  4. Complete metal analysis, as done for 1984 Snow Project, should be considered. Sample treatment with 20 mL of 50% nitric acid should be used (presently being carried out).
  5. Gran plot titration calculations should be made for all samples and compared with pH. Procedure modifications may be required to ensure proper results (presently being carried out).
  6. Nitrogen-containing compounds should be stored with  $H_2SO_4$  at pH 2 separate from regular samples.
  7. Additional treatment tests should be continued at Sandalta (i.e., entrainment, field storage temperatures, and sample exposure to ambient air).
  8. Because precipitation can vary dramatically within and between events, every effort should be made to collect the entire portion of all events at each station.

Stringent quality control and quality assurance procedures are essential for obtaining accurate, precise, and representative precipitation samples and for demonstrating sample integrity during collection, handling, and analysis. A proper quality control/quality assurance program must be implemented to ensure that high quality data is collected, to provide maximum credibility to the program, and to provide data users with representative data of documented accuracy, precision, and completeness. With the limited amount of field QA/QC carried out by the AOSERP network, it is not possible to provide quantitative estimates of data quality in terms of accuracy and precision.

### 3.2 REVIEW AND DOCUMENTATION OF THE AOSERP SNOW SURVEYS

As part of the AOSERP research program, several winter snow chemistry studies were carried out to evaluate and estimate the environmental importance of the dry deposition process within the AOSERP study area. The major mechanisms for conducting these studies were the sampling and chemical analysis of the snowpack from several locations within the AOSERP study area. The snowpack chemistry surveys conducted are summarized in Table 18.

#### 3.2.1 Survey Objectives and Design Plan

The following is a summary of the objectives of the AOSERP snow surveys during the years 1976, 1978, 1981, 1983, and 1984.

The 1976 survey studied the deposition patterns of sulphur resulting from emissions, during the winter months, from the GCOS (a.k.a. Suncor) plant. Chemical analysis was performed on samples from 56 different sampling sites located within 25 km of the plant for pH, conductivity, and sulphur.

The 1978 survey was expanded to include more extensive chemical analysis (for selected major ions and trace metals) for 60 sampling sites within a 100 km radius of the plant, because it became apparent that heavy metals, which were also emitted in significant amounts from the plant, may intensify the environmental problems within the AOSERP study area.

The 1981 snow chemistry survey was executed to determine whether the increased emissions from the new Syncrude plant had led to increased deposition and, therefore, snowpack loadings. The 1981 snow survey sampled at the same sites and analysis was carried out for the same parameters as the 1978 survey. Upon completion of the first three snow surveys, it became evident that most pollutants were transported outside the AOSERP study area. The need to extend the surveyed area to greater distances from the contamination sources was the main justification in the 1983 survey and provided the means for assessing the influence of local and distant emission sources. Therefore, the study area covered was extended to a 120 km radius and

Table 18. Summary of snow chemistry studies completed.

Study Date	Participants	Number of Sampling Sites	Parameters Analysed	Reference
1976 Mar. 3-9	Alberta Research Management Division and Atmospheric Environment Service Downsview, Ontario	56 sampling sites within 25 km of the Great Canadian Oil Sands plant (GCOS)	pH, conductivity, sulphur	AOSERP Report No. 27 (1978)
1978 Jan. 25-28	Alberta Research Management Division and Atmospheric Environment Service Downsview, Ontario	60 sampling sites within 100 km of the GCOS plant	pH, conductivity, alkalinity, sulphate, chloride, nitrate, soluble silica, ammonia, potassium, sodium, magnesium, calcium, aluminum, iron, nickel, vanadium	AOSERP Report No. 90 (1980)
1981 Jan. 10-13 1981 Feb. 20-23	PROMET Environmental Group Ltd., Calgary, Alberta	60 sampling sites within 100 km of the GCOS plant	pH, alkalinity, sulphate, chloride, nitrate, ammonia, potassium, sodium, calcium, magnesium, aluminum, iron, nickel, vanadium, manganese, titanium	AOSERP Report No. 125 (1981)
1983 Feb. 15-19 1983 Mar. 21-24	Alberta Research Management Division with brief assistance from PROMET, of Calgary, Alberta	50 sampling sites within 120 km of the GCOS plant	pH, alkalinity, conductivity, sulphate, chloride, nitrate, ammonia, sodium, calcium, magnesium, aluminum, manganese, titanium, potassium, vanadium, iron	No complete AOSERP report available to review
1984 Jan. 23-27 1984 Feb. 16-20 1984 Mar. 15-19	Alberta Research Management Division	50 sampling sites within 120 km of the GCOS plant	pH, alkalinity, acidity, conductivity, sulphate, chloride, nitrate, nitrite, ammonia, sodium, calcium, magnesium, barium, potassium, lithium, manganese, phosphate, copper, nickel, vanadium, iron, lead and arsenic, boron, beryllium, bismuth, cadmium, cobalt, chromium, mercury, molybdenum, antimony, selenium, thorium, uranium, zinc, and some organic acids	No complete AOSERP report available to review

the number of sites were reduced to 50 for both the 1983 and the 1984 surveys (Gourlay, 1983).

In the 1984 survey, the same sites and procedures were used as in 1983, except that several additional chemical parameters were analysed.

### 3.2.2 Sampling Site Selection Criteria Evaluation

The quality assurance subgroup of the Long Range Transport of Atmospheric Pollutants (LRTAP) task force under the auspices of the Federal-Provincial Research and Monitoring Coordinating Committee is presently developing standard protocols for snow chemistry studies. Fifteen different snow chemistry networks are being reviewed and evaluated in order to complete this task (personal communication with H.A. Wiebe, AES, 1985).

Recommendations from the LRTAP task force on precipitation studies (Bardswick, 1983; CSC, 1983c), served as the basis to prepare criteria to be considered when selecting sampling sites for a snow chemistry survey. These criteria are given in Section 8.5. This list of site selection criteria will serve as a guide to assess the criteria developed and used for the AOSERP network.

In 1976, 1978, and 1981, all AOSERP sampling sites were located within a 100 km radius of the GCOS plant, which was and still is the main local source of pollution in the AOSERP study area. All sites were reached by helicopter, except those on the river and along Highway 63, which were accessible by snowmobile and automobile respectively. The degree to which these sites may have been contaminated by rotor downwash and vehicular emissions is unknown. Each location was selected, where possible, in forest clearings away from sources of blowing dust and organic material from trees in an attempt to avoid local sources of contamination. However, the degree to which these sites were situated around nearby obstructions, or the degree of accessibility, is unknown.

For the 1983 and 1984 snow surveys, sampling was made easier and ground contamination was avoided by selecting sites on frozen bodies of water. The 50 sites were either located on a body

of water or an Alberta Forest Service landing strip. All sites were within 120 km of Syncrude or Suncor, the two main local sources of pollution, and were accessible by helicopter. The following list of recommendations were introduced by the RMD to prevent local sources of sample contamination for the 1983/1984 surveys:

1. The exact site must be sampled each time to ensure long-term site comparability of data, rather than aerially selected at random as was done in the past. This will be achieved by having separate landing site and sampling site markers present at all stations if not already in place.
2. The sampling site should be as far from the landing site as is convenient (several hundred metres). To prevent contamination during landings and takeoffs, the sampling site should be located perpendicular to the prevailing wind direction. Neglecting local topographic effects, this would mean either east or west of the landing site.
3. Site descriptions, along with maps and photographs should be made or updated for each station.
5. Where possible, the sampling site should be at least 2 to 3 heights away from the nearest snow shed or tree.

It is evident that more care was taken in 1983/1984 in selecting representative sampling sites that were free of as many local sources of contamination as possible. The sites were well distributed in the study area (Figure 5) and in a variety of topographic locations. However, detailed documentation of the selected sites is not available. The available information is listed in Section 8.6. Consequently, a qualitative assessment of the AOSERP sampling sites cannot be completed.

In order to assess the representativeness and suitability of the sampling sites, the following information is required:

1. A complete site drawing, to scale, with relative heights and distances of neighboring trees or buildings;



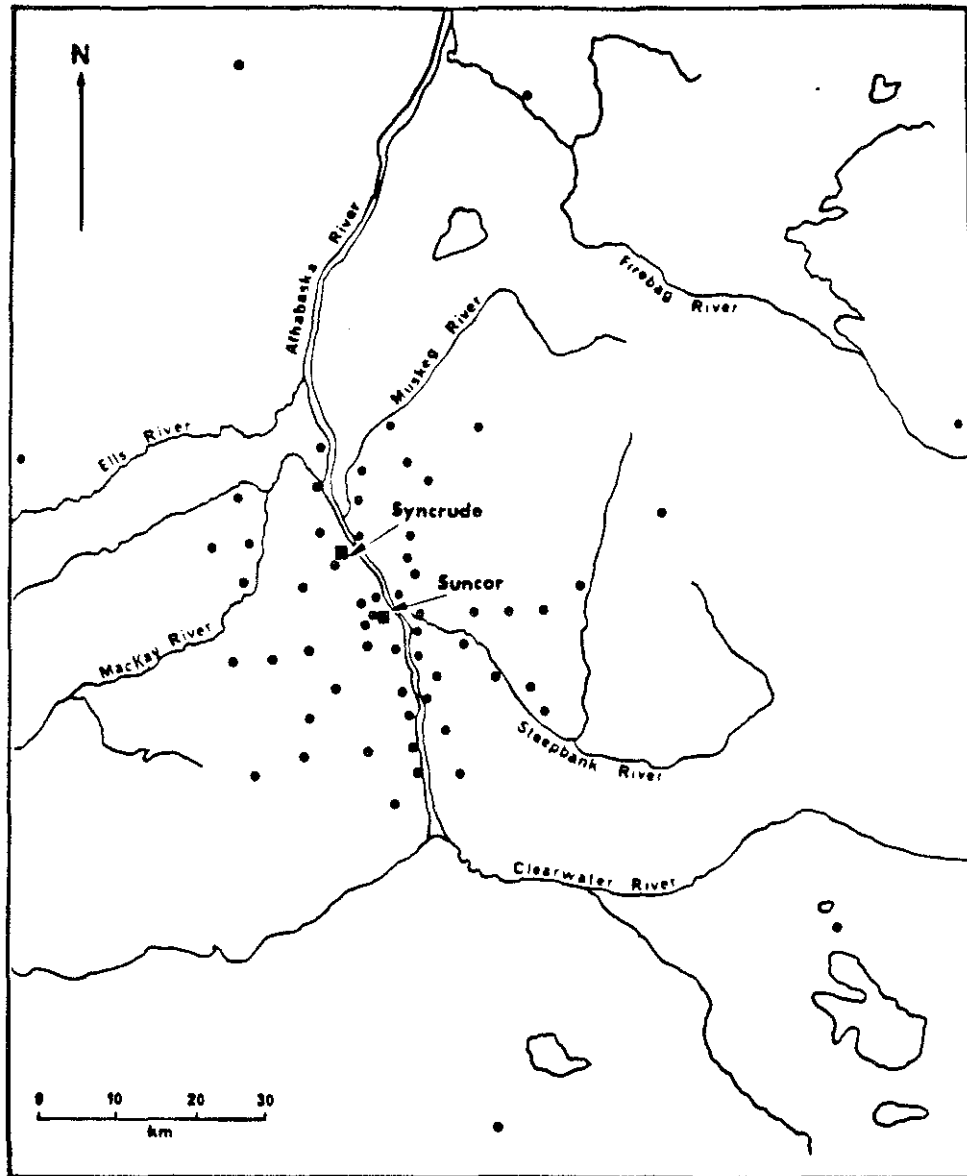

Figure 5. AOSERP snowcore sampling sites, 1983 to 1984.

2. Details of potential local sources of contamination; and
3. A description of the surrounding topography.

The representativeness of the sampling sites is a major part of the quality assurance program. Rigorous site selection criteria and detailed site descriptions and histories are essential in order to provide data users with the means of assessing the suitability of the data collected at a given site. Once representative monitoring locations have been selected and established, routine site evaluations are required to assess their ongoing changes. A suggested site documentation package is found in Section 8.7.

### 3.2.3 Field Operations

3.2.3.1 Sample collection. To obtain a representative snowpack sample, the monitoring network must develop and follow a detailed procedures manual. The procedures suggested in the manual must ensure that sample integrity is maintained during sample collection, handling, and shipping. Complete field operations will be described and evaluated for the AOSERP network in terms of sample quality for each study period. A brief summary of sample handling procedures is recorded in Table 19.

Sampling procedures as documented by the AOSERP network for the 1976, 1978, and 1981 surveys are found in Section 8.8.

The original survey in 1976 used a specially designed sampler that consisted of a half cylindrical aluminum tube. This was also used in 1978 for samples collected for major-ion analysis. In 1978, samples also were collected for trace-metal analysis; consequently the aluminum sampler was not used as it represented a potential source of sample contamination. Instead, an acrylic snowpack sampler of the same design was used.

In 1978, at four of the 60 sites, five cores were obtained individually using both the aluminum and acrylic samplers. The cores were analysed separately for both major ions and trace metals to determine any sampler effects on the chemical composition of the

Table 19. Summary of snowcore sample handling procedures.

Year	Affiliation Responsible for the Field Operations	Type of Sampler Used	Status of Sample	When, How, and Where the Samples Were Thawed	Preliminary Field Analysis	Sample Preserving Techniques	Shipping Procedures	Laboratory Responsible for the Chemical Analysis
1976	Atmospheric Environment Service Downsview, Ontario	Aluminum (major-ions) by Kovalick	Frozen	All samples were thawed at room temp. just prior to field analysis.	Volume, pH, conductivity	The samples were preserved but the technique was not documented.	Samples were melted and stored in polyethylene bottles.	Atmospheric Environment Service, Downsview, Ont.
1978	Atmospheric Environment Service Downsview, Ontario	Aluminum (major-ions) by Kovalick Acrylic (trace metals)	Frozen	All samples were thawed at 30°C just prior to the field analysis.	Volume, pH	The major-ion samples were not preserved; The trace metal samples were preserved with HNO <sub>3</sub> (pH=1.5).	Samples were melted and stored in polyethylene bottles and shipped refrigerated at 4°C.	Atmospheric Environment Service Downsview, Ontario
1981	Promet Environmental Group Ltd. Calgary, Alberta	Acrylic (major-ions and trace metals) Designed by Dr. F. Fanaki	Frozen	NIL	NIL	NIL	All samples were shipped frozen in their polyethylene bags, via a refrigerated truck.	Chemex Laboratories Calgary, Alberta and Barringer Magenta Toronto, Ontario
1983	Promet Environment Research Management Division	Acrylic (major-ions and trace metals)	Frozen	NIL	NIL	NIL	All samples were shipped frozen in their polyethylene bags, via a refrigerated truck.	Alberta Environment, Alberta Environmental Centre Chemistry wing, Dr. N. Das
1984	Alberta Environment, Research Management Division	Acrylic (major-ions and trace metals)	Frozen	NIL	NIL	NIL	All samples were shipped frozen in their polyethylene bags, via a refrigerated truck.	Chemex Laboratories Calgary, Alberta

snowpack samples. As a result of this study (Barrie and Kovalick, 1980), the use of the aluminum sampler was discontinued altogether. The sampler used for 1981, 1983, and 1984 surveys was designed and supplied by the Atmospheric Environment Service, Downsview, Ontario. It consisted of an acrylic half cylindrical tube, 1 m long and 80 cm<sup>2</sup> in cross-section. The flat side of the device was detachable to facilitate removal of the snowcore (see Figure 6). It proved to be very rugged and much more convenient to use. The acrylic snowcore sampler currently used cannot be compared to another type, because there is no other type available.

During all field studies except for 1976, two snow samples were collected per site: one for major ion analysis, and one for trace metals analysis. Each sample consisted of three snowcores. The three cores were placed in one polyethylene bag. A core sample consisted of the entire depth of the snowpack except for the bottom 4 cm. The bottom 4 cm were not collected because of the design of the sampler, to minimize sample contamination due to ground contamination. This is a good field practice. In 1976 only one sample (3 cores) was collected for major ion analysis; no samples for trace metal analysis were obtained.

Three snowcores were found to be sufficient to complete all the desired chemical analysis, as long as the snow depth was approximately 30 cm. When the snow depth decreases, the field technicians should be aware that four or five cores may be required.

Weaknesses identified (within the early sample collection procedures) that may affect sample quality and operational efficiency are:

1. The field procedures did not list all equipment required to ensure that the equipment was available and operational.
2. Operators were provided with an Information Sheet containing general rather than explicit instructions for sampling procedures. This may have led to misinterpretation of instructions and thus poor sample quality.

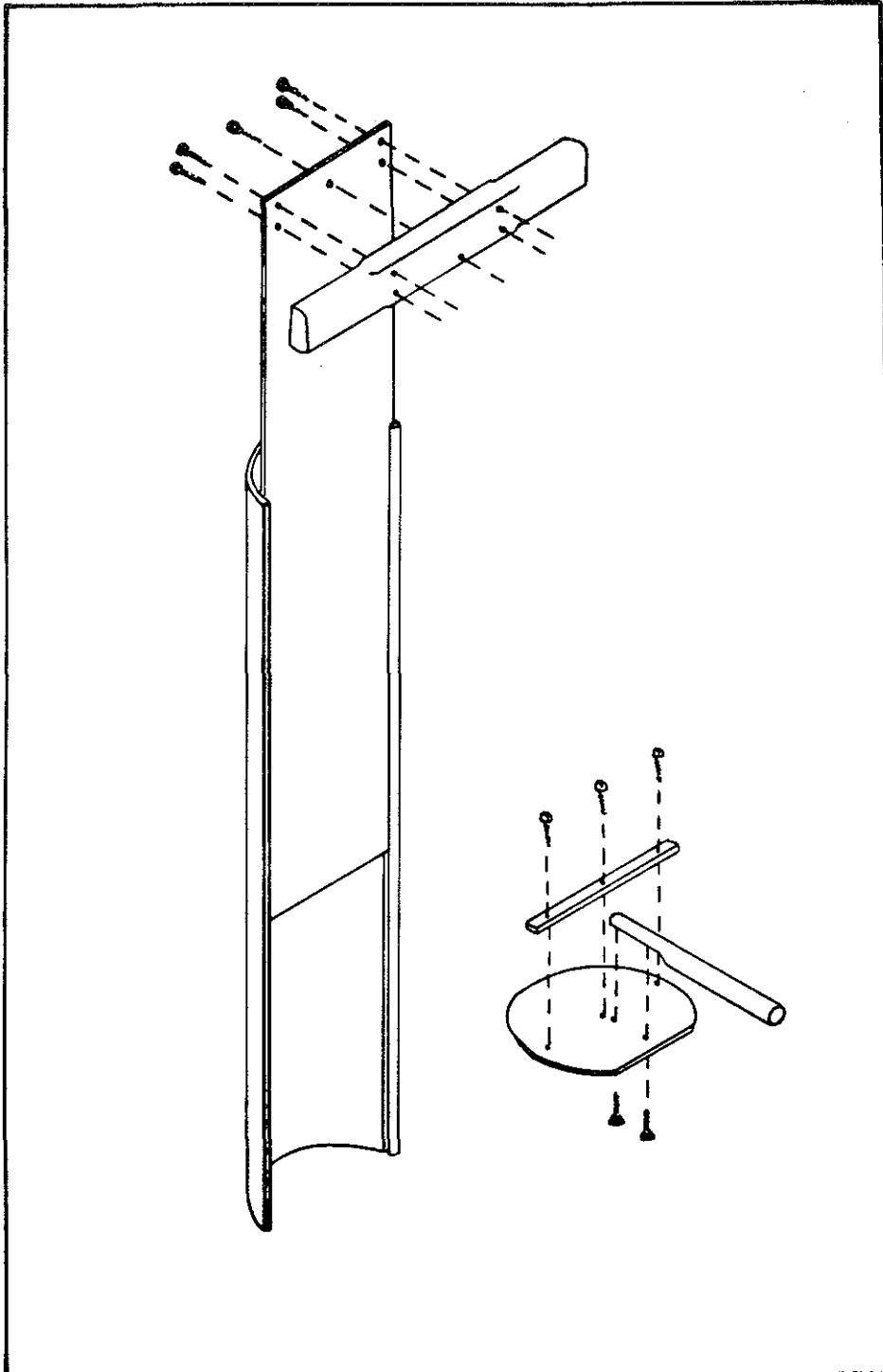

Figure 6. Snow corer.

3. The information sheet did not stress the importance of preventing sample contamination. Specific instructions such as "Land the helicopter downwind (several hundred metres) of the sampling site to avoid sample contamination from rotor-downwash, and snowshoe upwind to the site," should be included.
4. The procedures did not provide specific instructions for sample transfer from the collection vessel to the polyethylene bags. This is a critical step to avoid sample-sampler cross-contamination. The operator should place the snow into a new polyethylene bag, without touching the corer surface with the inner surface of the bag. The operator should wear new disposable polyethylene gloves while handling all equipment and samples, and should handle only the outside of the polyethylene bags.
5. The field procedures also should include sample handling procedures to ensure the chemical integrity of the sample after collection as was done in 1983 (e.g., "Put snow sample and sampler into the unheated compartment of the helicopter").
6. To ensure that the minimum amount of liquid sample is obtained to perform all the desired chemical analyses, the operator should know approximately how many cores per sample to obtain (this will depend on the snow density/water equivalency of the snowpack).
7. The field procedures should clearly state the type and number of QA samples to obtain to validate sampling protocols (number of field duplicate or replicate samples to be obtained).
8. The field procedures should also enforce the use of field data collection forms. This record is useful for examination and assessment of the local potential sources of sample contamination.

The sampling procedures used to obtain a snowcore in 1983 and 1984 are documented in Section 8.9.

After reviewing both the earlier and later field sampling procedures, it is evident that many of the earlier problems were rectified in 1983. Operators were provided with a procedures manual. The procedures manual was more explicit in describing helicopter landing, measuring the snow depth, removing the snowcore from the sampler, and inserting it into the bags. In addition to describing sampling methods in more detail, the procedures manual also gave instruction on equipment and supplies required, sample handling procedures, and the importance of obtaining pertinent field data. However, the 1983/1984 field procedures did not contain routine field maintenance procedures or QA/QC guidelines. These should be incorporated into the procedures manual and a training course should be provided for all technical staff.

3.2.3.2 Sample handling and shipping. When sufficient snow was collected, the polyethylene sample bags were twisted tightly and sealed using a plastic cable tie. In 1983 and 1984, samples were also placed in a second bag and knotted. The samples were then placed in the unheated portion of the helicopter until arrival at the field station where they were stored in a larger freezer. In the earlier studies (1976 and 1978), snow samples were kept frozen in their plastic bags until immediately prior to the preliminary field analysis. In 1976, melting was performed at room temperature. Preliminary field assessments used the following procedures:

1. Each snowcore was divided into two sections (top and bottom), separating the old and new snow. This is difficult to do, especially with shallow snow depths, so this procedure was discontinued for later studies.
2. The melt water volume of each section was measured.
3. The pH was measured using with a Fisher Accumet 320 Research pH meter.
4. The electrical conductivity was measured using a Radiometer conductivity meter, type CDM 2f, with a 5 mL capacity cell.

5. Sample aliquots were preserved.

Samples were transported to the main laboratory at Atmospheric Environment Service, Downsview, Ontario for analysis of sulphate. It is important to note here that the sample preservation techniques and shipping procedures for 1976 were not fully documented.

In 1978, melting was done at 30°C. Then samples collected for major-ion analysis with the aluminum sampler were handled in the following manner:

1. Meltwater volume was measured with a 1 L polyethylene volumetric cylinder.
2. The pH was measured with an Orion digital pH meter and combination electrode.
3. A 250 mL aliquot was placed in a polyethylene bottle that had been cleaned with a mild detergent and rinsed thoroughly with distilled water.

Samples were transported to the main laboratory at AES, Downsview, Ontario; stored refrigerated at 4°C; and analysed for major ions within a month.

Procedures for samples collected for metals analysis with the acrylic corer are described below:

1. Meltwater volume was measured with a 1 L polyethylene volumetric cylinder.
2. The meltwater was filtered through a 0.45  $\mu\text{m}$  Sartorius cellulose acetate filter (SM-1106).
3. The filter was then folded so that particulate matter is on the inner face and stored in a polyethylene "whirlpack" bag.
4. Approximately 280 mL of the filtered liquid was acidified to pH 1.5 with ultrapure concentrated nitric acid (BDH Aristar 45004).
5. Twenty-five and 250 mL linear polyethylene bottles were filled with the acidified samples.

The acidified meltwater and filters were transported to the AES laboratory for analysis.



For the later studies (1981, 1983, and 1984), the snowcore samples were stored in freezers at the AOSERP Mildred Lake Research Facility until the end of each collection period. The samples were shipped in a 0.6 m<sup>3</sup> container provided by the shipper. The sides of the container were padded with cardboard to prevent puncturing of the bags. Samples were kept frozen at the laboratory until required for analysis, and were then warmed to ambient air temperature just before analysis began. Samples were stored at 4°C between the analyses.

In 1981 the frozen samples were shipped to Chemex Laboratories of Calgary, Alberta. The 18 duplicate samples were melted, bottled in 1.5 L polyethylene bottles, and shipped at 4°C to Barringer Magenta of Toronto, Ontario. In 1983, frozen samples were shipped to the main laboratory of Alberta Environment for chemical analysis. In 1984 frozen samples were shipped to Chemex Laboratories of Calgary, Alberta, for chemical analysis (see Table 19 for summary of sample handling procedures).

In summary, the AOSERP sample collection storage and shipping procedures of 1983/1984 ensured the chemical stability/integrity of samples for subsequent chemical analysis by the methods described. The AOSERP network has used the proper sample containers (i.e., polyethylene sample bags and bottles) for chemical analysis of major ions and trace metals, and has also implemented standard sample preservation techniques (Environment Canada, 1979).

To properly assess the cleaning procedures for the snow corer and sample containers used in the AOSERP network, a review of the QA data on the container blanks would be necessary. However, according to the Environment Canada Analytical Methods Manual (1979), the standard cleaning procedures should include an acid wash and many deionized water rinses as done in 1983 and 1984. The procedure included:

- a 3-day soak in 1N high purity acid (HCl or HNO<sub>3</sub>)
- a triple rinse with deionized water
- a 3-day soak in deionized water
- a triple rinse with deionized water

The sampler was then inserted into a large polyethylene bag, closed, and repacked in its travelling carton. In addition to this, during each field session in 1983, the sampler was acid washed three times. Hydrochloric acid was repeatedly sprayed onto the inside surfaces of the collector and both sides of the paddle. It was then rinsed with deionized water until the conductivity of the rinse water was the same as pure water (less than 10  $\mu\text{S}/\text{cm}$ ). A portable conductivity meter was used to measure the conductivity of the rinse water. This procedure was not performed in the field because of the difficulty of conducting it properly. The polyethylene bags used to store the snowcores after sampling were not acid washed. However, they were run through a QC program and remained in a sealed cardboard box until used.

To ensure that all the samples arrived at the particular laboratory well packed, labelled, and with the proper sample history sheets, a review of the laboratories' sample reception information would be necessary. However, such reports were not made available. The major recommendations for changes to the procedures for obtaining snowcore samples are:

1. Consider placing dry ice packs around the sample bags while they are in the unheated portion of the helicopter. Ensure the sample bags are not stored next to spare fuel, heaters, or other sources of contamination.
2. Design a study to investigate the effects of storage time on the chemical stability of the sample and document the results.
3. Ensure the preserving techniques do not affect the chemical stability of the sample.
4. Minimize sample transfers.
5. Minimize the storage period of samples.
6. Ensure handling by reliable personnel.

3.2.3.3 Field data collection. For every field sampling survey a field data collection form must be completed. This form should contain the following information:

- Site number
- Sample number
- Date
- Operator
- Physical description of the sampling site (if different from what was expected)
- Type of sampler used and its dimensions
- Operational difficulties encountered while locating the site
- Operational difficulties encountered during the sampling process
- Total snow depth and description
- Core descriptions
- Weather conditions

This type of information is very useful when assessing the sample quality because it can inform data users of potential sources of contamination. It supplies data users with some meteorological history of the snowpack, wind directions, and maximum and minimum daily temperatures. For the earlier studies (1976, 1978, and 1981), there is no available field collection form to review. In 1983 and 1984, a sample collection form was employed (Figure 7). Although the form contains all the required information, forms were not routinely completed, which may indicate that the form was inconvenient to complete while working in the field or that the technical staff did not understand its importance.

3.2.3.4 Quality assurance for field operations. A field quality assurance program can provide (1) the means of ensuring that the data collected are of sufficient quality to meet the network objectives, and (2) quantitative estimates of confidence in the data in terms of precision, accuracy, and representativeness.

STATION: \_\_\_\_\_ SAMPLE NO.: \_\_\_\_\_  
 DATE COLLECTED: \_\_\_\_\_ TIME COLLECTED: \_\_\_\_\_  
 TYPE OF SAMPLER: \_\_\_\_\_ SAMPLER X-SECTION (cm<sup>2</sup>): \_\_\_\_\_

PHYSICAL DESCRIPTION OF SAMPLE SITE: \_\_\_\_\_  
 \_\_\_\_\_  
 \_\_\_\_\_

APPROXIMATE DISTANCE TO NEAREST LARGE VEGETATION(m): \_\_\_\_\_

CORE NUMBER	1	2	3	4	5	6	AVERAGE
TOTAL SNOW DEPTH (cm)							
FRESH SNOW DEPTH (cm)							
ICE LAYER DEPTH(S) (cm) (from ground)							
CORE LENGTH REMOVED (cm)							
CORE LENGTH RETAINED (cm)							

TOTAL SAMPLE LENGTH RETAINED (cm) \_\_\_\_\_  
 TOTAL SAMPLE VOLUME RETAINED (cm<sup>3</sup>) \_\_\_\_\_  
 TOTAL SAMPLE WEIGHT (gm) \_\_\_\_\_  
 TOTAL SAMPLE DENSITY (gm/cm<sup>3</sup>) \_\_\_\_\_

CONTAMINATION IN RETAINED CORE (indicate approximate amounts):

CORE	GRASS	LEAVES	NEEDLES	INSECTS	ROCKS/DIRT	FIBRES	OTHER
1							
2							
3							
4							
5							
6							

WEATHER CONDITONS (estimated):

CLOUD COVER (1/10's) \_\_\_\_\_ PRECIPITATION TYPE: NONE \_\_\_\_\_  
 WIND SPEED (m/s) \_\_\_\_\_ RAIN \_\_\_\_\_  
 WIND DIRECTION (±5°) \_\_\_\_\_ SNOW \_\_\_\_\_  
 FOG \_\_\_\_\_ BLOWING SNOW \_\_\_\_\_ PRECIPITATION INTENSITY \_\_\_\_\_

SAMPLE THAWED DURING TRANSPORT: YES NO  
 SAMPLE ARRIVED AT LAB FROZEN: YES NO  
 SAMPLE ARRIVED AT LAB PUNCTURED: YES NO

DATE(S) SAMPLE ANALYZED: \_\_\_\_\_

OTHER COMMENTS: \_\_\_\_\_  
 \_\_\_\_\_  
 \_\_\_\_\_

SAMPLE COLLECTED BY: \_\_\_\_\_

SAMPLE ANALYZED BY: \_\_\_\_\_  
 \_\_\_\_\_

Figure 7. Winter precipitation chemistry project sample collection form.

The five quality assurance elements are defined in the introduction to this chapter. The type of quality assurance applied in the AOSERP snow chemistry studies are summarized in Table 20. The degree of quality assurance applied in the AOSERP snow chemistry studies are summarized below.

In 1976 no field QA program was implemented. In 1978, field blanks of distilled water in sample bags were processed and analysed together with actual samples. From the analytical results, the detection limit of each measurement was defined. The composition of five individual samples (labelled A to E) was obtained for sites M, SW5, R4, and N1. From these data, the intra-site variation of concentration measurement expressed as per cent standard deviation of the mean was estimated.

A comparison of pH measured in the field and later in the laboratory shows that, in meltwater with initial pH above 5, the latter is higher than the former and the difference increases with increasing pH. Between pH 6 and 7, laboratory pH is about 0.5 units higher than field pH. This difference is likely due to the presence of calcium and magnesium oxides that slowly dissolve during the period between sampling and analysis. It would require only 0.014 mg·L<sup>-1</sup> of Ca<sup>2+</sup> (0.5 to 1 mg·L<sup>-1</sup> of Ca<sup>2+</sup> found) in snowmelt to dissolve at pH 6 to 7 to explain a pH change from 6 to 6.5. Thus, even though pH is altered significantly, the concentration of soluble calcium is not. Below pH 5, hydrogen ions become relatively more important in the ion balance of a solution, however, no significant difference between field and laboratory pH was observed.

In 1981, at nine of the 60 sites, four samples of three cores were obtained. The first and second bags were sent to Chemex Laboratories and the third and fourth were sent to Barringer Magenta Ltd. for chemical analysis. This procedure allowed an evaluation of the variability in results expected due to intra-site (within site) variability, and provided a cross-check of laboratory calibrations.

In 1983 and 1984, five duplicate samples were taken at three different locations (out of a possible 50 sites) for evaluation of intra-site variability.

Table 20. Field QA/QC procedures - snowpack.

QA/QC Sample	Description	Nature of Control QA Parameter Measured	1976 1978 1981 1983 1984					
			1976	1978	1981	1983	1984	
Co-located Sampling	Two samplers used to collect snow at one site	- overall site/sample precision (includes instrument, operator, shipping and laboratory precision)						- difficult to do with type of sampler; in this case replicate samples were taken
Split Samples	One large volume of snow was collected from one site, one sampler; melted combined, together and split. Both parts are submitted for analysis (assume sample homogeneity)	- sample handling and analytical precision	✓	✓	✓	✓	✓	
Replicate Samples	Obtain several samples from one site with one sampler and analyse all separately	- overall variability (precision) of snow samples		✓	✓	✓	✓	
Bottle/Bag Blanks	New or clean, unused sample bags or bottles were submitted from the field for blank analysis using deionized water	- sample accuracy relative to sample combination						
Bottle/Bag QA	Checked new inventory of bottles and bags for contamination	- procurement QA to investigate the potential contamination absorption characteristics						
In-Field QC - on pH Measurements	Compared pH data between the field and lab measurements			✓				

In summary, the AOSERP snow chemistry network did not follow a well defined quality assurance plan and few QC samples were obtained.

Routine reporting and interpretations of all QA elements for every snow chemistry survey is essential for evaluation of data. It is especially important that estimates of accuracy and precision be reported in a manner that facilitates their use for determining the effectiveness of the monitoring program. If there are any field measurements taken associated with the snow sample, the relevant QA checks also should be completed and documented. A documented QA plan is required for snowpack surveys.

### 3.3 LABORATORY SAMPLE ANALYSIS AND QA/QC

The sample and data handling procedures within the laboratory are extremely important to ensure that every sample collected in the field appears in the final database with documented accuracy and precision.

#### 3.3.1 Laboratory QA/QC

The major objective of a laboratory quality control program for chemical analysis is to ensure immediate detection and solution of analytical problems. These can include:

1. instrumentation;
2. chemical reagents and standards;
3. analytical techniques and;
4. calibration.

A systematic application of quality control procedures of two major types are required to perform this function. First, "function checks," in which the validity of the sample and performance of the equipment is controlled, and second, "control checks," in which the performance of the analytical system is verified and the results are monitored for acceptability in precision and accuracy.

The function checks confirm that the instrument operated correctly and that the analytical procedure ran under proper conditions at the time of analysis. These types of checks are to be

carried out prior to and during each analytical run to confirm operational integrity, and include:

1. verification of sample integrity, including expiry date and storage or sample handling procedures (via sample and data custody procedures);
2. checks on instrument stability, drift, warm-up time, etc. prior to operation;
3. checks that zero, span, and operating ranges are properly adjusted; and
4. assurance that operation is under controlled environmental conditions (particularly temperature).

Control checks provide a measure of the accuracy and precision associated with the data, and identify deteriorating or out-of-control conditions as they develop. This ensures that immediate attention is given to analytical problems. These control checks consist of many different types of samples (blanks, spike, or real samples), and are discussed below.

3.3.1.1 Calibration procedure and verification. Instrument calibration is performed to determine the instrumental response to known concentrations of target compounds. Calibration consists of preparation and analysis of standard solutions (traceable to reference materials) over the full range of instrument responses. Calibration curves determined by these standards provide the relationship between sample concentration and instrument response. The calibration is then verified by means of control standards (e.g., QC-A, QC-B) that are made up independently of the calibration standards and are chosen to be about 70% and 10% of full scale, respectively.

When the QC-A and QC-B control standards are analysed and read, their sum and difference are calculated, plotted for each run on a control chart, and used immediately by the technician to determine whether the calibration process is in control. This is done by calculating the mean ( $\bar{X}$ ) and standard deviation ( $\sigma_X$ ) of a number of repeated measurements. It is common practice (U.S. EPA, 1976) to set the warning limits at  $\bar{X} \pm 2\sigma_X$  and the out-of-control limits at  $\bar{X} \pm$



$3\sigma_x$ . The probability of results exceeding these levels is, therefore, 5% and 1% for the warning and control limits, respectively.

3.3.1.2 Recovery checks. In methods requiring sample preparation, such as digestion or extraction, a suitable recovery check is required to estimate the efficiency of the preparation method. These solutions are not used to calibrate the instrument, but corrections for the preparation blank and matrix effects can be estimated and applied if necessary. Recovery standards are chosen to test all facets of the analysis. If a digestion step results in extraction of a substance or conversion of one substance into another before analysis, the recovery standard should be chosen to test the efficiency of this step. Poor agreement between duplicate standards indicates deterioration of within-run precision or problems with recovery of the recovery check standards.

3.3.1.3 Precision. Precision refers to the reproducibility of a measurement technique when it is repeated on a homogeneous sample under controlled conditions. Within the run, precision may be determined by the analyst through the non-consecutive reanalysis of real precipitation samples. Within each run (or after a given number of samples) the analyst should repeat an earlier analysis of a real sample to determine the replicability of the result within an individual run. Standard deviation values from within-run duplicates are used to estimate the within-run precision, detection criteria, and detection limit.

Between-run precision (repeatability) can be determined by having the same sample analysed on different days by the same or different analysts. This repeated analysis would provide a measure of day-to-day or analyst-to-analyst variability. Usually day to day variations are larger than within-run variations.

Another type of between-run investigation could be undertaken if different instruments (i.e., same technique at different stations within the laboratory) are used for the same analytical

determination. In this case, the same sample would be analysed at the different stations to provide a measure of "between-instrument" precision. Split samples also may be introduced to provide independent assessment of between-run or between-instrument precision.

3.3.1.4 Accuracy. The calibration of the instrument and calibration control (QC samples) procedures described above are used to establish the analytical accuracy. An estimate of the laboratory's accuracy is obtained from intercomparison studies with other laboratories or by analysing standard reference materials (SRM). These samples are then submitted to the analysis system without the analysts' knowledge to assess the accuracy within and between analytical runs, analysts, and/or instruments. Similar determinations of laboratory accuracy may be obtained through the introduction of prepared standard samples or spiked real samples from the field and the use of external audits and laboratory intercomparisons.

3.3.1.5 Blanks. The analysis of "blank" samples may be used to assess various types of bias or contamination. Within the laboratory, these types of analyses include checks on reagents, deionized water, sample handling procedures, and contamination of sample containers or glassware. The most important of these is the reagent blank, which consists of a deionized water sample prepared and handled as though it were a real sample to check for any random sample contamination or inconsistencies that may occur during sample handling and analysis.

Table 21 summarizes the various types of control samples discussed in this section. This summary lists the type of sample, a brief description of each, and the nature of the control. Tables 22 and 23 summarize the laboratory QA/QC level of effort during the AOSERP precipitation and snowcore studies, respectively.

### 3.3.2 Laboratory Sample Reception, Preparation, and Handling

The major function of the laboratory sample reception process is to act as the interface between the field monitoring acti-

Table 21. Summary of laboratory and network quality control sample types.

Type of Sample	Description	Nature of Control
Blank	Deionized water (or another appropriate "blank") is analysed to adjust the baseline or zero setting of the instrument to a suitable reading on the chart recorder or other readout.	Set up analytical instrument. Detection of deterioration in instrumentation.
Reagent Blank	Deionized water QC sample is subjected to the same preparation procedure as routine samples to be analysed.	Checks for random contamination that may occur in sample preparation or reagents. A measure of lab bias.
Handling Blank	Deionized water QC sample is subjected to the same handling procedures as routine samples being analysed.	Checks for random contamination, leaching, & adsorption that may occur in sample handling, i.e., glassware, sample containers, bags, etc. A measure of lab bias.
Different Run	Randomly chosen previously analysed samples.	Provides information on analytical precision for different days of analysis.  CHECK - between-run repeatability.
Within Run	Randomly chosen previously analysed sample within the same run. One is analysed at the beginning of the run with the QC standard and recovery standard and the other of the pair is analysed in the regular sample order.	Provides information on analytical precision within a run. Analyst can use standard deviation values from within-run duplicates to estimate the within-run precision, detection criteria, and detection limits.
Split Samples	Randomly chosen precipitation samples split into two aliquots by the QC chemist and submitted "blind" to the laboratory for analysis.	Checks within-lab precision.
Co-located Field Samples	Samples submitted to laboratory from co-located sites.	Checks operational, lab, and network precision.

continued ...

Table 21. Concluded.

Type of Sample	Description	Nature of Control
Calibration Standards	Prepared by analyst. Standard solutions covering the range of instrument responses are analysed before the analytical run commences.	Checks within-run accuracy, laboratory bias, and instrument response.
Quality Control Standards	Prepared by analyst. Two standard solutions QC-A, QC-B are made up and maintained independently of the calibration standards at about 70% and 10% of full scale.	Checks within- and between-run accuracy used as calibration control, control charting, and Youden plots - to control slope and blank bias.
Internal Lab Audit Samples	Prepared by Quality Control Chemist and are made up and maintained independently of the calibration standards and submitted "blind" to analyst.	Checks analytical accuracy and assess data quality independently of the laboratory analyst.
Spiked Real Samples	Spiked sample prepared by the Quality Control Chemist submitted "blind" to the analyst.  Where spiked sample = simulated rain-water samples containing all major constituents.  QC chemist calculates % recovery.	Checks sample recovery.
Standard Reference Samples	Analysis of standard reference materials.	To establish bias for the calibration and analysis steps.
Recovery Standards	Recovery standards prepared at 0%, 20%, 40%, and 80% of full scale. Analysed in the same manner as regular samples.	Test efficiency of digestion.  Correct for digestion blank and matrix effect.  Calculate % recovery.
Round Robins Standards	QC samples submitted with the knowledge of the laboratory but "blind" to the analyst and QC samples submitted "blind" to the laboratory.	Measure lab accuracy.
Audits Prepared Synthetic Samples		

Table 22. Laboratory QA/QC - precipitation studies.

Sample Type	1976	1977	1978	1979	1981	1982	1983	1984
Blank					✓		✓	✓
Reagent Blank								✓
Handling Blank							✓	✓
Different Run					✓			
Within Run	✓	✓	✓	✓	✓	✓	✓	✓
Split Sample	✓	✓	✓	✓	✓	✓	✓	✓
Co-located Field Samples							✓	
Calibration Standard	✓	✓	✓	✓	✓	✓	✓	✓
Quality Control Standard <sup>a</sup>								
Internal Lab Audit								
Spiked Real Sample	✓	✓	✓	✓	✓	✓	✓	✓
Standard Reference <sup>a</sup>								
Recovery Standard <sup>a</sup>								
Round Robin	✓	✓			✓	✓		✓
Audits								

<sup>a</sup> The documentation of the type and number of standards used is poor; however, the laboratories probably ran several types of standards for at least calibration purposes.

Table 23. Laboratory QA/QC - snowcore studies.

Sample Type	1976	1978	1981	1983	1984
Blank		✓	✓		✓
Reagent Blank					
Handling Blank					
Different Run					
Within Run					
Split Sample					
Co-located Field Samples		✓	✓	✓	✓
Calibration Standard	✓	✓	✓	✓	✓
Quality Control Standard					
Internal Lab Audit				✓	
Spiked Real Sample				✓	✓
Standard Reference					
Recovery Standard					
Round Robin					
Audits					✓
Dilution Samples			✓		

vities and the laboratory analysis procedures by verifying the validity of samples upon receipt at the laboratory. Submitting the samples (along with their appropriate sample documentation) into the laboratory analysis stream and immediately storing the samples under proper conditions at the laboratory until analysis can be initiated is the first step that must be taken.

The laboratory sample reception must therefore submit the samples, along with their documentation, into the laboratory analysis stream, and ensure that:

1. samples are stored properly,
2. samples are labelled,
3. analyses are scheduled,
4. preliminary QA/QC checks are performed, and
5. samples are distributed to the appropriate work area.

The following standard sample handling procedures are required for:

A. Precipitation Samples

The event precipitation samples are shipped in insulated containers with freezer packs to maintain low temperatures. Once delivered to the laboratory they are immediately placed into cold storage until they are processed at the sample reception desk. Precipitation samples are delivered to sample reception in their polyethylene bottles/bags, along with their laboratory submission forms.

The samples are inspected and assigned laboratory numbers and properly logged into the laboratory system. If the samples are in polyethylene bags, the bags and contents are weighed and the volumes recorded. A corner of the bag is cleaned with deionized water and cut with clean scissors, then the sample is transferred into a clean labelled polyethylene bottle, with care being taken not to lose any sample. The samples are then sent to the precipitation laboratory for analysis. Samples are refrigerated at 4°C prior to and between analyses.

The AOSERP sample storage and handling procedures for precipitation chemistry samples are summarized in Table 24.

Table 24. Summary of laboratory sample storage and handling procedures for precipitation samples.

Study Year	Field Analysis	Shipping Container	Shipping Procedure	Analytical Laboratory	Sample Storage and Handling	Comments
1976	pH, conductivity	- polyethylene bottles	- shipped in ice-packed coolers	Chemical and Geological Laboratories Ltd. Edmonton, Alberta	stored at 4°C	fair
1977	pH, conductivity	- polyethylene bottles	- shipped in ice-packed coolers	Chemical and Geological Laboratories Ltd. Edmonton, Alberta	stored at 4°C	fair
1978	NIL	- polyethylene bottles	- shipped in ice-packed coolers	For the period of 1978/1979, it is only assumed that the laboratory was also Chemical & Geological Labs Ltd. of Edmonton, Alberta	assumed to be stored at 4°C	
1979	NIL	- polyethylene bottles	- shipped in ice-packed coolers	For the period of 1978/1979, it is only assumed that the laboratory was also Chemical & Geological Labs Ltd. of Edmonton, Alberta	assumed to be stored at 4°C	
1981	NIL	- polyethylene sample bags and sealed with a wire twist tie	- shipped in ice-packed coolers	Alberta Environmental Centre Air Analysis Section Vegreville, Alberta	- samples were logged in - stored at 4°C - analysed within 5 working days - a flow sheet was maintained to monitor handling steps	good avoid twist ties
1982	NIL	- polyethylene sample bags sealed with a wire twist tie	- shipped in ice-packed coolers	Alberta Environmental Centre Air Analysis Section Vegreville, Alberta	- samples were logged in - stored at 4°C - analysed within 5 working days - a flow sheet was maintained to monitor handling steps	good
1983	half the samples were filtered and half were unfiltered upon arrival	- polyethylene bottles	- shipped in ice-packed coolers	Kananaskis Centre for Environmental Research University of Calgary		special study
1984	NIL	- heated sealed polyethylene collection bags	- packed in steel Coleman coolers with ice-packs - shipped via PWA	Chemex Laboratories Calgary, Alberta	- samples were stored at 4°C - samples were shaken thoroughly - the corner in which the transfer was to take place was washed with deionized water - the contents of the sample bag were placed into a 1 L polyethylene graduated cylinder - graduated cylinder - volume measured - the samples were maintained at 4°C between analysis	excellent



It is evident that the AOSERP laboratory sample handling procedures for the earlier studies (1976 to 1983) have not been properly documented and, as a result, cannot be evaluated in terms of their effects on sample integrity.

The procedures developed and used by Chemex Laboratories in 1984 meet the standard procedures and should be implemented (see page 285 of this report).

#### B. Snow Samples

The snow samples are shipped in two polyethylene sample bags in a refrigerated truck and are properly packed to avoid punctures or thawing from occurring. Once delivered to the laboratory, they are immediately placed into cold storage until they are processed and thawed. Thawing should not occur until just prior to the start of the chemical analysis. Samples should be thawed overnight to allow them to reach room temperature. The sample bags and contents are then weighed and the volumes are recorded on the laboratory submission forms.

The sample is then transferred into pre-labelled clean sample bottles. The transferring procedures involve rinsing the outside of the sample collection bag with deionized water and shaking it, then elevating a corner of the bag and cutting it off with clean scissors to form a small spout and transferring the sample. The sample bottles for major-ion analysis are immediately placed in refrigerators and kept at 4°C until sample analysis procedures are initiated. The sample bottles for trace-metals analysis are then preserved with high quality nitric acid (0.2%) and then sent to the laboratory for analysis. The AOSERP sample storage and handling procedures for snowcore chemistry samples are summarized in Table 25.

It is evident that there has been inconsistency in the sample storage and handling procedures for winter precipitation samples from 1976 to 1984.

The procedures followed and documented for the 1983/1984 snow survey meet the standard protocols. The procedures used in 1981

Table 25. Summary of laboratory sample storage and handling procedures for snowcore samples.

Study Year	State of Sample	Shipping Container	Analytical Laboratory	Sample Storage and Handling Procedures
1976	liquid preserved	- polyethylene bottles - shipped by truck	Atmospheric Environment Service, Downsview, Ontario	- not reported
1978	liquid	- polyethylene bottles - stored at 4°C and shipped by truck	Atmospheric Environment Service, Downsview, Ontario	- not reported
1981	frozen	- polyethylene bags - shipped by refrigerated truck	Chemex Laboratories Calgary, Alberta Barringer Magenta Toronto, Ontario	- stored at -20°C upon arrival - melted at room temperature overnight - analysis started immediately - thawed samples were shipped in insulated coolers to Barringer in an unheated truck - storage during analysis was not reported
1983	frozen	- polyethylene bags - shipped by refrigerated truck	Alberta Environmental Centre Chemistry Wing Dr. N. Das	- snow samples stored at -20°C - melted at room temperature overnight in small batches - samples transferred to plastic bottles - analysis started immediately - samples stored at 4°C during the period of analysis
1984	frozen	- 2 polyethylene bags - stored in a padded cage and shipped via refrigerated truck	Chemex Laboratories Calgary, Alberta	- snow samples stored at -20°C - melted at room temperature overnight in their own containers - sample weight determined - the outside of the sample collection bag rinsed with deionized water and shaken - a corner of the bag cut and the sample transferred into the bottle - a portion of each sample poured into an acid-washed QC bottle, preserved with a 0.2% solution of HNO <sub>3</sub> and shipped to Quanta. Trace for metal analysis - the remainder of the sample poured into water-rinsed QC bottle for analysis Samples analysed for parameters in order of their stability (pH, HCO <sub>3</sub> within 12 h of thaw, acidity, gran plot filtration, anion scan, and organic acids within 48 hours, remainder of analysis within 5 days - all thawed samples, except during actual analysis, are stored at 4°C until analysis is complete

appear to have been sufficient, however, more information in sample storage during analysis would confirm this.

The chemical stability of samples collected in 1976 and 1978 is undocumented.

It is recommended that future programs use the sample storage and handling protocol as developed for the 1984 survey in order to ensure the chemical integrity of the samples.

Implementation of a chain of sample custody procedures (Figure 8) would ensure that all sample and data handling procedures are thoroughly understood and documented. Tight sample custody monitoring will enable laboratories and network personnel to keep track of the progress of all the samples from reception through to the splitting of samples for different analyses, the analyses themselves, and the final archiving or disposal of samples (CSC, 1984a).

### 3.3.3 Chemical Analysis

Once the laboratory analysis procedures have been selected and the details of the methodologies have been determined, the detection capabilities and limits for accuracy and precision should be established and documented. Reasonable estimates of sample throughput (i.e., the number of samples analysed per run or per day) also should be provided in order to permit laboratory planning and scheduling.

The operational procedures should then be documented in a formal laboratory operations manual, which should describe detailed laboratory and instrumental procedures, including general sample handling procedures, specific analytical procedures, calibration procedures, preparation of standards, instrument maintenance requirements, specifications of analytical methods (e.g., detection limits, concentration ranges), quality control checks to be applied, and data reporting procedures. Other documentation that should be available for routine operations includes the detailed laboratory QA/QC procedures as they relate to the particular analytical technique, control charts and limits, corrective action procedures, and a current list

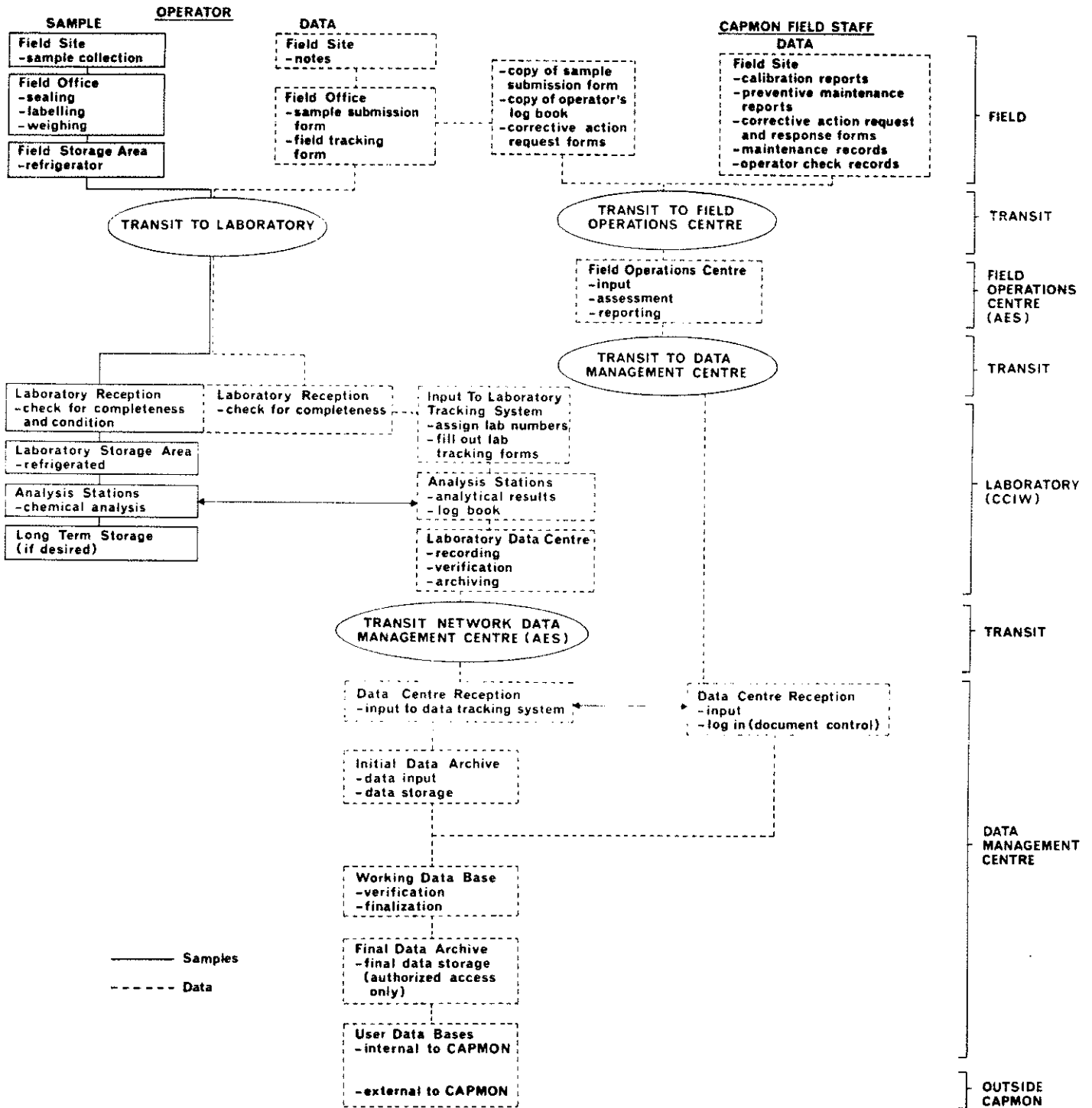

Figure 8. Chain-of-custody organization - sample and data.

of samples to be analysed. Once the operational and QA/QC procedures have been defined, all staff should undergo a comprehensive training program pertaining to their area(s) of responsibility. The laboratory procedures manuals on QA/QC guidelines, in combination with a training program, should ensure all samples are properly analysed and evaluated. In addition, results should be approved by the laboratory supervisor.

The analytical methods used by the AOSERP network for both summer and winter precipitation projects are tabulated by study year (Tables 26 to 35). These methods are good analytical methods and provide the required accuracy, precision, and sensitivity for analysis of precipitation and snowcore samples.

The most serious deficiency arises because of the lack of detailed documentation of procedures and techniques for conducting the sample analyses. Another important reservation regarding the results pertains to the analytical quality assurance program. Little evidence exists that points to a well defined quality assurance and quality control program. Apart from duplicate analysis and the occasional intercomparison studies, little documentation exists to define accuracy, precision, and comparability of laboratory analyses.

In 1984, Chemex worked in conjunction with the water quality laboratories at the Alberta Environmental Centre (AEC) for additional quality control checks. The Environmental Centre provided Chemex with two primary standards, one for the anions and one for cations, for analysis. A portion of this bulk sample was returned to AEC as a blind sample for comparative analysis. This is a good practice to follow; the next step would be to document the results so that during the data evaluation process one could calculate the laboratory precision.

Table 26. Methods of analysis for the summer precipitation project, 1976 to 1979.

Parameter Analysed	Method of Analysis	Detection Limit
pH	pH meter	not available
Alkalinity	Titration to pH 4.0 and back to 5.6 (under N <sub>2</sub> )	not available
Conductivity	Cell (25°C)	0.100 $\mu\text{mho}\cdot\text{cm}^{-1}$
Ammonia	Automated colorimetric phenate	0.050 $\text{mg}\cdot\text{L}^{-1}$
Nitrate - Nitrogen	Automated cadmium reduction	0.002 $\text{mg}\cdot\text{L}^{-1}$
Chloride	Automated thiocyanate	0.010 $\text{mg}\cdot\text{L}^{-1}$
Sulphate - Sulphur	Automated methylthymol blue	0.002 $\text{mg}\cdot\text{L}^{-1}$
Calcium	Plasma atomic emission	0.007 $\text{mg}\cdot\text{L}^{-1}$
Magnesium	Plasma atomic emission	0.020 $\text{mg}\cdot\text{L}^{-1}$
Sodium	Plasma atomic emission	0.020 $\text{mg}\cdot\text{L}^{-1}$
Potassium	Plasma atomic emission	0.020 $\text{mg}\cdot\text{L}^{-1}$
Phosphate - Phosphorous	Automated molybdates	0.002 $\text{mg}\cdot\text{L}^{-1}$

Laboratory: 1976 to 1978, Alberta Environmental Centre, Vegreville, Alberta  
 1978 to 1979, Chemex Laboratories Ltd., Calgary, Alberta

Table 27. Methods of analysis for the summer precipitation project, 1981 to 1982.

Parameter Analysed	Method of Analysis	Detection Limit
pH	pH meter	0.500 pH units
Conductivity	Conductivity meter	0.100 $\mu\text{mhos}\cdot\text{cm}^{-1}$
Ammonia	Ion chromatography	0.010 $\text{mg}\cdot\text{L}^{-1}$
Nitrate	Ion chromatography	0.010 $\text{mg}\cdot\text{L}^{-1}$
Chloride	Ion chromatography	0.010 $\text{mg}\cdot\text{L}^{-1}$
Sulphate	Ion chromatography	0.010 $\text{mg}\cdot\text{L}^{-1}$
Calcium	Atomic absorption spectrometer	0.002 $\text{mg}\cdot\text{L}^{-1}$
Magnesium	Atomic absorption spectrometer	0.005 $\text{mg}\cdot\text{L}^{-1}$
Sodium	Ion chromatography	0.010 $\text{mg}\cdot\text{L}^{-1}$
Potassium	Ion chromatography	0.010 $\text{mg}\cdot\text{L}^{-1}$
Phosphate	Ion chromatography	0.010 $\text{mg}\cdot\text{L}^{-1}$
Fluoride	Fluoride electrode	0.050 $\text{mg}\cdot\text{L}^{-1}$
Heavy Metals	Inductively coupled argon plasma	not available

Laboratory: Alberta Environmental Centre, Air Analysis Section  
Vegreville, Alberta

Table 28. Methods of analysis for the summer precipitation project, 1983.

Parameter Analysed	Method of Analysis	Detection Limit
pH	pH meter	not reported
Conductivity	Conductivity meter	not reported
Ammonia	Ion chromatography	0.002 mg·L <sup>-1</sup>
Bromine	Ion chromatography	0.002 mg·L <sup>-1</sup>
Nitrate	Ion chromatography	0.002 mg·L <sup>-1</sup>
Chloride	Ion chromatography	0.002 mg·L <sup>-1</sup>
Sulphate	Ion chromatography	0.002 mg·L <sup>-1</sup>
Calcium	Atomic absorption spectrometer	0.002 mg·L <sup>-1</sup>
Magnesium	Atomic absorption spectrometer	0.002 mg·L <sup>-1</sup>
Sodium	Ion chromatography	0.002 mg·L <sup>-1</sup>
Potassium	Ion chromatography	0.002 mg·L <sup>-1</sup>

Laboratory: Kananaskis Centre for Environmental Research  
University of Calgary



Table 29. Methods of analysis for the summer precipitation project, 1984.

Parameter Analysed	Method of Analysis	Detection Limit
pH	Titration	0.02
Alkalinity	Titration	0.05
Acidity	Gran plot titration	0.05
Conductivity	Conductivity meter	0.1 $\mu\text{S}\cdot\text{cm}^{-1}$
Ammonium	Ion chromatography	0.005 $\text{mg}\cdot\text{L}^{-1}$
Nitrate	Ion chromatography	0.001 $\text{mg}\cdot\text{L}^{-1}$
Nitrite	Ion chromatography	0.001 $\text{mg}\cdot\text{L}^{-1}$
Chloride	Ion chromatography	0.001 $\text{mg}\cdot\text{L}^{-1}$
Sulphate	Ion chromatography	0.010 $\text{mg}\cdot\text{L}^{-1}$
Calcium	Atomic absorption	0.005 $\text{mg}\cdot\text{L}^{-1}$
Magnesium	Atomic absorption	0.005 $\text{mg}\cdot\text{L}^{-1}$
Sodium	Ion chromatography	0.005 $\text{mg}\cdot\text{L}^{-1}$
Potassium	Ion chromatography	0.01 $\text{mg}\cdot\text{L}^{-1}$
Phosphate	Ion chromatography	0.005 $\text{mg}\cdot\text{L}^{-1}$
Lactate	Ion chromatography	0.1 $\text{mg}\cdot\text{L}^{-1}$
Formate	Ion chromatography	0.1 $\text{mg}\cdot\text{L}^{-1}$
Acetate	Ion chromatography	0.1 $\text{mg}\cdot\text{L}^{-1}$
Propionate	Ion chromatography	0.1 $\text{mg}\cdot\text{L}^{-1}$

Laboratory: Chemex Laboratories Ltd.  
Calgary, Alberta

continued ...

Table 29. Concluded.

Parameter Analysed	Method of Analysis	Detection Limit
Soluble metals		
Aluminum	Atomic absorption graphite tube furnace	0.001 mg·L <sup>-1</sup>
Vanadium	Atomic absorption graphite tube furnace	0.001 mg·L <sup>-1</sup>
Iron	Atomic absorption graphite tube furnace	0.001 mg·L <sup>-1</sup>
Nickel	Atomic absorption graphite tube furnace	0.001 mg·L <sup>-1</sup>
Chromium	Atomic absorption graphite tube furnace	0.001 mg·L <sup>-1</sup>
Titanium	Atomic absorption graphite tube furnace	0.001 mg·L <sup>-1</sup>
Insoluble metals		
Aluminum	Atomic absorption	0.6 µg
Vanadium	Atomic absorption	0.4 µg
Iron	Atomic absorption	0.1 µg
Nickel	Atomic absorption	0.06 µg
Chromium	Atomic absorption	1.8 µg
Titanium	Atomic absorption	0.04 µg
Zinc	Atomic absorption	0.4 µg
Copper	Atomic absorption	0.04 µg
Lead	Atomic absorption	0.04 µg
Manganese	Atomic absorption	0.04 µg

Laboratory: Quanta Trace of Vancouver

Table 30. Methods of analysis for the snowcore project, 1976.

Parameter Analysed	Method of Analysis	Detection Limit
pH	Fisher Accumet pH meter	
Conductivity	Radiometer Conductivity Meter CDM - 2F	
Sulphate as S	Isotope Dilution Technique	0.01 mg·L <sup>-1</sup>

Laboratory: Atmospheric Environment Service  
Downsview, Ontario

COMMENTS:

Documentation of the laboratory procedures, methods of analysis, or a QA/QC plan was not available for review for 1976.

Table 31. Methods of analysis for the snowcore project, 1978.

Parameter Analysed	Method of Analysis	Detection Limit
pH (Field)	Electrode	not available
pH (Lab)	Orion digital pH meter and combination electrode	not available
Alkalinity	Titration to pH = 4 and back 5.6	not available
Ammonia	Alk-Phenol (colorimetric)	0.001 mg·L <sup>-1</sup>
Nitrate	Cadmium reduction (colorimetric)	0.005 mg·L <sup>-1</sup>
Chloride	Mercury thiocyanate (colorimetric)	0.06 mg·L <sup>-1</sup>
Sulphate	Methyl - thymolblue (colorimetric)	0.01 mg·L <sup>-1</sup>
Calcium	Atomic absorption	0.05 mg·L <sup>-1</sup>
Magnesium	Atomic absorption	0.01 mg·L <sup>-1</sup>
Sodium	Flame photometric	0.02 mg·L <sup>-1</sup>
Potassium	Flame photometric	0.06 mg·L <sup>-1</sup>
Aluminum (soluble)	Solvent extraction Atomic absorption	0.001 mg·L <sup>-1</sup>
Nickel (soluble)	Solvent extraction Atomic absorption	0.002 mg·L <sup>-1</sup>
Vanadium (soluble)	Neutron activation	0.002 mg·L <sup>-1</sup>
Iron (soluble)	Solvent extraction Atomic absorption	0.0012 mg·L <sup>-1</sup>
Aluminum (insoluble)	Neutron activation	not available
Vanadium (insoluble)	Neutron activation	not available
Manganese (insoluble)	Neutron activation	not available
Titanium (insoluble)	Neutron activation	not available
Soluble Silica (SiO <sub>2</sub> )	Molybdate - oxalic acid (colorimetric)	0.002 mg·L <sup>-1</sup>

Laboratory: Atmospheric Environment Service  
Downsview, Ontario

## COMMENTS:

Documentation of laboratory procedures, methods of analysis, or a QA/QC plan is not available for review for 1978.

Table 32. Methods of analysis for the snowcore project, 1981.

Parameter Analysed	Method of Analysis	Detection Limit
pH	Electrode	
Alkalinity	Titration to pH = 4 and back 5.6	
Ammonia	Alk-Phenol (colorimetric)	0.001 mg·L <sup>-1</sup>
Nitrate	Cadmium reduction	0.003 mg·L <sup>-1</sup>
Chloride	Mercury thiocyanate (colorimetric)	0.06 mg·L <sup>-1</sup>
Sulphate	Ion chromatography	0.01 mg·L <sup>-1</sup>
Calcium	Atomic absorption	0.05 mg·L <sup>-1</sup>
Magnesium	Atomic absorption	0.01 mg·L <sup>-1</sup>
Sodium	Flame photometric	0.02 mg·L <sup>-1</sup>
Potassium	Flame photometric	0.06 mg·L <sup>-1</sup>
Aluminum (soluble)	Solvent extraction Atomic absorption	0.001 mg·L <sup>-1</sup>
Nickel (soluble)	Solvent extraction Atomic absorption	0.001 mg·L <sup>-1</sup>
Vanadium (soluble)	Solvent extraction Atomic absorption	0.001 mg·L <sup>-1</sup>
Iron (soluble)	Solvent extraction Atomic absorption	0.002 mg·L <sup>-1</sup>
Aluminum (insoluble)	Neutron activation	1.0 µg·L <sup>-1</sup>
Vanadium (insoluble)	Neutron activation	0.1 µg·L <sup>-1</sup>
Manganese (insoluble)	Neutron activation	0.1 µg·L <sup>-1</sup>
Titanium (insoluble)	Neutron activation	50.0 µg·L <sup>-1</sup>

Laboratory: Chemex Laboratories Ltd.  
Calgary, Alberta

NOTE:

The filtered samples of the insoluble metals were analysed by Nuclear Activation Services Ltd., Hamilton, Ontario.

COMMENTS:

Documentation of the laboratory procedures, methods of analysis, or a QA/QC plan was not available for review for 1981.

Table 33. Methods of analysis for the snowcore project, 1981 (QA/QC).

Parameter Analysed	Method of Analysis	Detection Limit
pH	Electrode	
Alkalinity	Titration to pH = 4 and back 5.6 under N <sub>2</sub>	
Ammonia	Ion chromatography	0.01 mg·L <sup>-1</sup>
Nitrate	Ion chromatography	0.01 mg·L <sup>-1</sup>
Chloride	Ion chromatography	0.01 mg·L <sup>-1</sup>
Sulphate	Ion chromatography	0.01 mg·L <sup>-1</sup>
Calcium	Ion chromatography	0.01 mg·L <sup>-1</sup>
Magnesium	Ion chromatography	0.01 mg·L <sup>-1</sup>
Sodium	Ion chromatography	0.01 mg·L <sup>-1</sup>
Potassium	Ion chromatography	0.02 mg·L <sup>-1</sup>
Aluminum (soluble)	Inductively coupled plasma	0.005 mg·L <sup>-1</sup>
Nickel (soluble)	Inductively coupled plasma	0.005 mg·L <sup>-1</sup>
Vanadium (soluble)	Inductively coupled plasma	0.001 mg·L <sup>-1</sup>
Iron (soluble)	Inductively coupled plasma	0.002 mg·L <sup>-1</sup>
Aluminum (insoluble)	Inductively coupled plasma <sup>a</sup>	0.005 mg·L <sup>-1</sup>
Vanadium (insoluble)	Inductively coupled plasma <sup>a</sup>	0.001 mg·L <sup>-1</sup>
Manganese (insoluble)	Inductively coupled plasma <sup>a</sup>	0.010 mg·L <sup>-1</sup>
Titanium (insoluble)	Inductively coupled plasma <sup>a</sup>	0.005 mg·L <sup>-1</sup>

Laboratory: Barringer Magenta Ltd.  
 Toronto, Ontario  
 (Barringer received 9 duplicate samples and blank samples from Chemex)

<sup>a</sup> Samples from the second study period were analysed for insoluble heavy metals using the neutron activation method.

Table 34. Methods of analysis for the snowcore project, 1983.

Parameter Analysed	Method of Analysis	Units $\mu\text{eq/L}$	
		minimum	maximum
pH	Electrode	0.32	61.66
Alkalinity	Titration	0.08	15.79
Conductivity	Meter	not available	
Ammonia	Ion chromatography	2.22	38.25
Nitrate	Ion chromatography	7.26	24.67
Chloride	Ion chromatography	0.28	13.26
Sulphate	Ion chromatography	8.12	74.96
Calcium	Atomic absorption	0.48	86.80
Magnesium	Atomic absorption	0.84	33.72
Sodium	Ion chromatography	0.43	42.63
Potassium	Ion chromatography	not available	
Phosphate	Ion chromatography	0.36	15.48

Parameter Analysed	Method of Analysis	Standard Deviation (from duplicate)
Aluminum (insoluble)	X-ray fluorescence	0.018 $\mu\text{g/cm}^2$
Manganese (insoluble)	X-ray fluorescence	0.0084 $\mu\text{g/cm}^2$
Titanium (insoluble)	X-ray fluorescence	0.036 $\mu\text{g/cm}^2$
Iron (insoluble)	X-ray fluorescence	0.026 $\mu\text{g/cm}^2$
Vanadium (insoluble)	X-ray fluorescence	0.084 $\mu\text{g/cm}^2$

Laboratory: Alberta Environmental Centre  
Vegreville, Alberta

Table 35. Methods of analysis for the snowcore project, 1984.

Parameter Analysed	Method of Analysis	Detection Limit
pH (Field)	Electrode	0.02
Acidity	Titration	0.05
Alkalinity	Titration	0.05
Conductivity	Meter	0.1 $\mu\text{S}\cdot\text{cm}^{-1}$
Ammonia	Ion chromatography	0.005 $\text{mg}\cdot\text{L}^{-1}$
Nitrate/Nitrite	Ion chromatography	0.005 $\text{mg}\cdot\text{L}^{-1}$
Chloride	Ion chromatography	0.001 $\text{mg}\cdot\text{L}^{-1}$
Sulphate	Ion chromatography	0.01 $\text{mg}\cdot\text{L}^{-1}$
Calcium	Ion chromatography	0.005 $\text{mg}\cdot\text{L}^{-1}$
Magnesium	Ion chromatography	0.005 $\text{mg}\cdot\text{L}^{-1}$
Sodium	Ion chromatography	0.005 $\text{mg}\cdot\text{L}^{-1}$
Potassium	Ion chromatography	0.01 $\text{mg}\cdot\text{L}^{-1}$
Phosphate	Ion chromatography	0.005 $\text{mg}\cdot\text{L}^{-1}$
Formate	Ion chromatography	0.1 $\text{mg}\cdot\text{L}^{-1}$
Acetate	Ion chromatography	0.1 $\text{mg}\cdot\text{L}^{-1}$
Propionate	Ion chromatography	0.1 $\text{mg}\cdot\text{L}^{-1}$
Arsenic	Inductively coupled plasma	0.2 $\text{mg}\cdot\text{L}^{-1}$
Boron	Inductively coupled plasma	0.01 $\text{mg}\cdot\text{L}^{-1}$
Beryllium	Inductively coupled plasma	0.001 $\text{mg}\cdot\text{L}^{-1}$
Cadmium	Inductively coupled plasma	0.002 $\text{mg}\cdot\text{L}^{-1}$
Cobalt	Inductively coupled plasma	0.005 $\text{mg}\cdot\text{L}^{-1}$
Chromium	Inductively coupled plasma	0.002 $\text{mg}\cdot\text{L}^{-1}$
Copper	Inductively coupled plasma	0.005 $\text{mg}\cdot\text{L}^{-1}$
Mercury	Inductively coupled plasma	0.05 $\text{mg}\cdot\text{L}^{-1}$
Molybdenum	Inductively coupled plasma	0.01 $\text{mg}\cdot\text{L}^{-1}$
Nickel	Inductively coupled plasma	0.01 $\text{mg}\cdot\text{L}^{-1}$
Lead	Inductively coupled plasma	0.05 $\text{mg}\cdot\text{L}^{-1}$
Antimony	Inductively coupled plasma	0.05 $\text{mg}\cdot\text{L}^{-1}$
Selenium	Inductively coupled plasma	0.05 $\text{mg}\cdot\text{L}^{-1}$
Thorium	Inductively coupled plasma	0.1 $\text{mg}\cdot\text{L}^{-1}$
Uranium	Inductively coupled plasma	0.3 $\text{mg}\cdot\text{L}^{-1}$
Vanadium	Inductively coupled plasma	0.002 $\text{mg}\cdot\text{L}^{-1}$
Zinc	Inductively coupled plasma	0.005 $\text{mg}\cdot\text{L}^{-1}$

Laboratory: Chemex Laboratories Ltd.  
 Calgary, Alberta  
 (subcontract Quanta Trace Laboratories, Inc., Burnaby, B.C.)

## COMMENTS:

See Section 8.9 for a review of the terms of reference Chemex was to follow. Detailed analytical documentation and QC conclusions are not available for review.



#### 4. DATA EVALUATION

##### 4.1 INTRODUCTION

One of the primary purposes of this project is the assessment of the quality of the data generated throughout the operation of the network based on the quantitative analysis of data. (Note that the operational evaluation has been addressed also in Section 3.) In order to carry out this assessment, it was first necessary to assemble the raw data into a convenient and accessible format. Details of these procedures were described in Section 2 together with an evaluation of the existing data storage practices and recommendations for future database practices. The assessment of the data involved the application and subsequent analysis of screening procedures as well as data analysis to determine the precision and, where possible, the accuracy of the individual or aggregate components of the monitoring process.

The screening procedures identified and flagged "suspect" data and/or samples based on the application of criteria to identify outliers for individual parameters or groups of parameters. It should be noted for purposes of subsequent data analysis that the suspect data were physically separated from the data set and separate files (flag files) were generated also to qualify the separation.

Ideally, the suspect data should be further investigated through contact with field and laboratory personnel and examination of relevant field and/or laboratory documents based on timely data validation and analysis programs. In view of the fact that data spanning over eight years are under investigation, such contacts are inappropriate and only limited use was made of some of the available data sheets in order to assess some cases of suspect data. The analysis, therefore, involved noting statistics on the screening process and the identification of patterns in the screening process. This aspect is described in Section 4.2.

In order to determine the accuracy and precision of the sampling and analytical protocols, the following aspects were considered:

1. For rain data, the catch efficiency of the rain sampler was determined using the ratio of the sampler catch to a standard bulk rain gauge catch at the site. Standard rain gauge data from the Canadian Climatological Data digital archive of the Atmospheric Environment Service were obtained and used for this purpose.
2. For snowcore data, significant thaw periods just prior to snowcore sampling were reviewed to determine whether or not chemical redistribution of the snowcore during thaw periods may have occurred.
3. Data for blank samples were reviewed to check for random contamination that may have occurred in sample preparation.
4. Laboratory duplicate data were analysed to determine the degree of data variability introduced due to laboratory sample handling.
5. Replicate data, obtained from co-located sampling, were also reviewed to assess the intra-site variability (i.e., imprecision introduced by sampling methodologies).

A review of interlaboratory comparison data was also attempted to determine the performance of analytical laboratories, but could not be completed due to the lack of information.

#### 4.2 DISCUSSION OF DATA SCREENING RESULTS

The protocol for executing the screening routines involved identification of outliers, determination of the incidence of simultaneous concentrations of selected parameters, and determination of anion-to-cation ratios.

The screening routines first identified outliers, and appropriate flags were added to a special flag file. Data that passed the outlier screening test, and those that did not (i.e., outliers), were written to separate files. The second stage of screening used the "outliers-screened" data file, and applied two parallel

screening programs. The first attached flags to the data from each sample, based on selected parameters increasing or decreasing in synchrony (e.g., simultaneous high values for  $\text{Ca}^{2+}$  and  $\text{Mg}^{2+}$  may be indicative of soil contamination in the sample). In the second program, anion-cation ratios (A/C) were calculated, and data were flagged according to the A/C ratio in the following ranges:  $A/C < 0.5$ ,  $0.5 < A/C < 1.5$ ,  $A/C > 1.5$ , and no ratio (A/C missing) due to missing concentration values. The limits for the A/C range were arbitrarily chosen but they are identical to those used in screening precipitation data from networks such as CAPMoN and APIOS, for example, and several networks in the U.S.

The screening process created three new data files:

1. A file containing only validated data;
2. A file containing data excluded from the original set;  
and
3. A file containing flags describing the outliers and anion-cation ratios.

#### 4.2.1 Data Outliers

One of the most important aspects of data validation is to identify outliers within the data set. An outlier is defined as an extreme value that may not belong to the data set due to some source of systematic bias. Outliers may indicate an error in the sample collection, laboratory analysis, or data reporting operations, or they may be due to real but highly unusual events. Outliers should therefore be identified, flagged, and subsequently investigated in order to qualify their validity.

Outliers can be identified by several statistical techniques. The one selected for this study assumed a lognormal distribution for the concentration data and established upper and lower screening limits (i.e.,  $\bar{X} \pm 2\sigma_g$ , where  $\bar{X}$  = geometric mean and  $\sigma_g$  = standard geometric deviation for annual data distributions throughout the network). Individual data points were classed as outliers if they were outside these limits. For precipitation chemistry data, the lower limits are usually the analytical detection limits, there-

fore, "low end" outliers are not normally observed. The complete data set was screened by parameter by year over all possible sampling stations. "High end" outliers were each flagged with a "1" and the outliers were excluded from the screened data set. Data within the established criteria (i.e., less than the mean plus two times the geometric standard deviation) were flagged with a "0" and were retained in the screened data set. Missing data were designated by a flag of "3". Missing data indicate the values were not available in the data set either because no sample was collected or because sample volume was insufficient to allow all the required analyses to be performed.

Data passing the outliers test were written into the final file of "screened data," while outliers were stored in a separate file of flagged data only.

Tables 36 and 37 summarize, by study year, the percentage of data in the original file that were flagged due to the presence of outliers.

From Tables 36 and 37, it is evident that there is no single "problem" parameter recurring every year for either the snow or rain study. However, most outliers are common major ionic species, namely,  $\text{NO}_3^-$ ,  $\text{NH}_4^+$ ,  $\text{SO}_4^{2-}$ ,  $\text{Mg}^{2+}$ ,  $\text{K}^+$ ,  $\text{Ca}^{2+}$ ,  $\text{Na}^+$ , and  $\text{Cl}^-$ , rather than trace elements.

On average for each year, 2 to 4% of the data were outliers. However, in 1984, 15% of the rain data and 8% of the snow data were outliers.

#### 4.2.2 High Concentration Samples

The second stage of screening used the screened data file, and applied a two-stage screening program. In the first stage, any sample in which  $\text{Ca}^{2+}$  and  $\text{Mg}^{2+}$  were in the upper 2% of the annual distribution was flagged with a "1" and the sample was excluded from the data set. These high values may be indicative of a specific type of sample contamination, for example, road salt, soil contamination, or dust originating from the ground or human activities. If three or more species (except any combination of  $\text{H}^+$ ,  $\text{NH}_4^+$ ,  $\text{SO}_4^{2-}$ , and  $\text{NO}_3^-$ ) were

Table 36. Outliers - AOSERP summer precipitation study.

Study Year	Percentage of Data Flagged As Outliers	Parameters Most Often Flagged As Outliers
1976	3.5	$\text{NH}_4^+$ , $\text{SO}_4^{2-}$ , $\text{NO}_3^-$ , $\text{Na}^+$ , $\text{K}^+$
1977	1.8	$\text{SO}_4^{2-}$ , $\text{SiO}_2^-$
1978	2.7	$\text{NH}_4^+$ , $\text{Na}^+$
1979	1.4	$\text{NH}_4^+$ , $\text{SO}_4^{2-}$ , alkalinity
1981	4.5	$\text{F}^-$ , $\text{Mn}^{2+}$ , $\text{Mg}^{2+}$ , $\text{Ca}^{2+}$ , $\text{K}^+$
1982	2.7	$\text{F}^-$ , $\text{Mg}^{2+}$ , $\text{Ca}^{2+}$ , $\text{K}^+$
1983	3	$\text{NO}_3^-$
1984	15	$\text{NH}_4^+$ , $\text{Mg}^{2+}$ , $\text{Na}^+$ , $\text{NO}_3^-$

Table 37. Outliers - AOSERP winter precipitation study.

Study Year	Percentage of Data Flagged As Outliers	Parameters Most Often Flagged As Outliers
1976	3.3	Conductivity
1978	6.1	Alkalinity
1981	2.5	$\text{Cl}^-$ , $\text{K}^+$ , $\text{Na}^+$ , Cu
1983	2.5	$\text{Cl}^-$ , $\text{K}^+$ , $\text{Na}^+$ , $\text{Mg}^{2+}$ , $\text{NH}_4^+$ , $\text{PO}_4^{3-}$ , $\text{SO}_4^{2-}$ , conductivity
1984	8	Zn, Cu, $\text{Cl}^-$ , $\text{K}^+$ , acidity

in the upper 2% of their distribution, the sample was flagged with a "2". Any combination of flags 1 and 2 was flagged "3". Other samples that passed the high concentration criteria were flagged "0".

In the second stage, flags were assigned to the data according to the calculated anion-cation ratio. The anion-cation ratio utilizes the fact that the net charge in the precipitation sample must be zero, therefore the ratio should be equal to one. The ratio is calculated for each sampling station by comparing the sum of anion equivalents ( $\text{SO}_4^{2-}$ ,  $\text{NO}_3^-$ , and  $\text{Cl}^-$ ) to the sum of cation equivalents ( $\text{H}^+$ ,  $\text{NH}_4^+$ ,  $\text{K}^+$ ,  $\text{Ca}^{2+}$ ,  $\text{Mg}^{2+}$ , and  $\text{Na}^+$ ). For example,

$$\text{Anions} = \frac{3[\text{PO}_4^{3-}]}{95} + \frac{2[\text{SO}_4^{2-}]}{96} + \frac{[\text{NO}_3^-]}{62} + \frac{[\text{Cl}^-]}{35.5} + \frac{[\text{F}^-]}{19} + \frac{[\text{Br}^-]}{80} +$$

$$\frac{[\text{NO}_3^- - \text{N}]}{14} + \frac{2[\text{SO}_4^{2-} - \text{S}]}{32}$$

(where each concentration, [ ], is divided by its gram equivalent weight) and,

$$\text{Cations} = \frac{[\text{H}^+]}{1} + \frac{2[\text{Ca}^{2+}]}{40} + \frac{2[\text{Mg}^{2+}]}{25.3} + \frac{[\text{K}^+]}{39} + \frac{[\text{Na}^+]}{23} + \frac{[\text{NH}_4^+]}{18} +$$

$$\frac{[\text{NH}_4^+ - \text{N}]}{14}$$

such that the anion-cation ratio =  $\frac{[\text{anion}]}{[\text{cation}]}$ .

If the ratio is greater than 1.0, a cation deficiency is indicated, whereas a ratio of less than 1.0 indicates an anion deficiency. A ratio outside the range 0.5 to 1.5 is indicative of a problem in the analysis or a missing chemical species.

If the sample's anion-cation ratio was less than 1.5 and/or greater than 0.5, the data were within the acceptable range and were flagged with a "0". These data were retained in the data set. If, however, the anion-cation ratio was less than 0.5, data were flagged with a "1" and the entire sample data were excluded from the data set. Similarly, if the ratio was greater than 1.5, the sample

data were flagged with a "2" and also excluded from the data set. Any sample lacking data required for the evaluation of the anion-cation ratio was flagged "."; however, the data were not excluded from the data set.

Tables 38 and 39 summarize, by year, the total percentage of data excluded from the NAQUADAT files, and give the reasons for exclusion.

It is evident that significant amounts of data were screened out from both the rain and snow files (i.e., 3 to 6.2%). However, the percentage of data that had both a high concentration value for  $\text{Ca}^{2+}$  and  $\text{Mg}^{2+}$  was relatively low (i.e., <3%), hence, random sample contamination was probably not a major problem. The 1981 snow and rain surveys had a particularly high relative standard error for all parameters studied, which suggests that the sample collection and handling procedures were very likely poorly controlled.

Many samples collected for the entire AOSERP program, winter or summer, were lacking concentration values for several major parameters. The reason for this is not fully understood; it could be the result of insufficient sample collected or simply lack of analysis. This was unfortunate, because the anion-cation ratio could not be calculated for such samples.

#### 4.3 QUALITY ASSURANCE ASPECTS OF THE SAMPLING AND ANALYTICAL PROTOCOLS

The quality assurance (QA) program for any network must ensure that each sample is representative of the study site, and that each sample is collected, handled, and analysed by precise, well documented methods. In order to assess these aspects, the following field and laboratory related data were reviewed and evaluated:

1. The sampler collection efficiency,
2. Significant winter thaw periods,
3. Blank samples,
4. Laboratory duplicate results,
5. Field replicate results, and
6. Co-located sampling results.



Table 38. Summary of screening programs for the AOSERP summer precipitation study.

Study Year	Percentage of Data Deleted Outliers	Type of Parameter Most Often Flagged for Outliers	High Concentration Flags Percentage of Data Deleted in Terms of Samples	Anion-Cation Ratio Percentage of Data Deleted in Terms of Samples	Total Percentage of Data Deleted from the Original Data Set from Screening Checks
1976	3.5	NH <sub>4</sub> <sup>+</sup> , SO <sub>4</sub> <sup>2-</sup> , NO <sub>3</sub> <sup>-</sup> , Na <sup>+</sup> , K <sup>+</sup>	3% lost because of high concentration of three or more species 1.4% lost because of high concentration of three or more species and of Ca and Mg	98% missing parameters 2.3% of the data is OK ~ A/C = 1	7.9%
1977	1.8	SO <sub>4</sub> <sup>2-</sup> , SiO <sub>2</sub> <sup>-</sup>	0.8% lost because of high concentration of three or more species	0.4% lost because A/C <0.5 99.6% of the samples missing parameters needed to calculate the A/C	4.0%
1978	2.7	Na <sup>+</sup> , NH <sub>4</sub> <sup>+</sup>	1% lost because of high concentration on three species 1.3% lost because of high concentration of three species and of Ca + Mg	100% of the samples missing parameters needed to calculate the A/C	1.4%
1979	1.4	NH <sub>4</sub> <sup>+</sup> , SO <sub>4</sub> <sup>2-</sup> Alkalinity	No evidence of sample contamination	100% of the samples missing parameters needed to calculate the A/C	1.4%
1981	4.5	F <sup>-</sup> , Mg <sup>2+</sup> , Mn <sup>2+</sup>	0.3% lost because of high Ca + Mg concentrations 6% lost because of high concentrations of three or more species 2.2% lost because of high concentrations of Ca + Mg + three or more other species	14.4% lost because A/C >1.5 4.1% lost because A/C <0.5 77% of the samples missing parameters needed to calculate the A/C	24.5%
1982	2.7	F <sup>-</sup> , Ca <sup>2+</sup> , K <sup>+</sup>	2.5% lost because three or more species have high concentrations 1.3% lost because Ca + Mg have high concentrations	4% lost because A/C <0.5 14% lost because A/C >1.5 76% of the samples missing parameters needed to calculate the A/C	24.5%
1983	3	NO <sub>3</sub> <sup>-</sup>	No evidence of sample contamination	100% of the samples missing parameters needed to calculate the A/C ratio	3.0%
1984	15	NH <sub>4</sub> <sup>+</sup> , Mg <sup>2+</sup> , Na <sup>2+</sup> , NO <sub>3</sub> <sup>-</sup>	0.6% lost because of high Ca + Mg concentrations 1.6% lost because of high concentrations of three or more species	100% of the samples missing parameters needed to calculate the A/C ratio	17.2%

Note: See Table 1 for a review of the entire parameters monitored for each year.

Table 39. Summary of screening programs for the AOSERP winter precipitation study.

Study Year	Percentage of Data Deleted Outliers	Type of Parameter Most Often Flagged for Outliers	High Concentration Flags Percentage of Data Deleted in Terms of Samples	Anion-Cation Ratio Flags Percentage of Data Deleted in Terms of Samples	Total Percentage of Data Deleted from the Original Data Set from Screening Checks
1976	3.3	Conductivity	No evidence of sample contamination.	Missing parameters to calculate A/C for all stations, therefore no data selected.	3.3% (a 3-parameter study)
1978	6.1	Alkalinity	Lost 1.3% because of high Ca + Mg concentrations.	Lost 10% because A/C <0.5; lost 8% because A/C >1.5; 55% of the samples missing parameters needed to calculate the A/C.	25.4%
1981	2.5	Cl <sup>-</sup> , K <sup>+</sup> , Na <sup>+</sup> , Cu	Lost 1% because of high Ca + Mg concentrations and 32.5% because of simultaneously high concentration of three or more species.	Lost 26% because A/C <0.5; 50% of the samples missing parameters needed to calculate the A/C.	62.0%
1983	2.5	Cl <sup>-</sup> , K <sup>+</sup> , Na <sup>+</sup> , Mg <sup>2+</sup> , NH <sub>4</sub> <sup>+</sup> , PO <sub>4</sub> <sup>3-</sup> , SO <sub>4</sub> <sup>2-</sup> Conductivity	Lost 1.6% because of three or more species simultaneously having high concentrations.	Lost 5% because A/C <0.5; lost 19.7% because A/C >1.5; 6% of the samples missing parameters needed to calculate the A/C.	28.8%
1984	8.0	Zn, Cu, Cl <sup>-</sup> , K <sup>+</sup> Acidity	Lost 0.3% because of three or more species simultaneously having high concentrations.	Lost 7% because A/C <0.5; lost 0.5% because A/C >1.5; 60% of the samples missing parameters needed to calculate the A/C ratio.	15.8%

Note: See Table 2 for a review of the entire parameter list for each year.

#### 4.3.1 Sampler Collection Efficiency

The collection efficiency of the rain sampler can be calculated as the ratio of the precipitation amount collected by the sampler to that collected by the standard precipitation gauge. The ratio will indicate to the data user the accuracy of the sample collection process. This is an important parameter to monitor because partial collection of an event may not provide a sample representative of the precipitation chemistry and will distort the determination of the amounts deposited by wet deposition. In cases where the collection efficiency is not found to be within acceptable limits, the sample should be flagged for further consideration. A low collection efficiency may indicate site-specific or precipitation-type specific peculiarities as well as poor sampler design or operation.

The acceptable limits for collection efficiency are typically 90 to 105%, but limits for each network should be established once network objectives have been established. Note that data from each network site should include information on the collection efficiency of each event so that data users are aware of any peculiarities and are able to make appropriate adjustments. These limits may be used to flag suspect samples or provide a basis for exclusion from further data analysis. Examination of the sampler and site-specific collection characteristics may lead to collection efficiency screening limits based on the precipitation type, time of year, or station location.

Once the screening limits are established, all samples in which the collection efficiency fails to meet the acceptable limits should be properly flagged and listed for further evaluation. The flag "abnormal collection efficiency" should be retained in the final database to alert data users to the potential collection problem. It should be noted that although screening of data based on collection efficiencies was not applied to the AOSERP data set, the reasons for the observed efficiencies and the implications of the observed efficiencies are discussed. The sampling schedule used in the AOSERP network (daytime collection only) would have resulted in all night rain samples being missed. Daily collection efficiencies would be

valid for days on which events occurred in the day only. Therefore, monthly efficiencies would be understandably low.

Daily sampler collection efficiencies were calculated by summing over the number of events reported each day. These calculations were possible only for stations with available standard rain gauge data and when sample volume data were recorded. The daily sampler collection efficiencies for the 1981, 1982, and 1984 surveys calculated are listed in Section 8.13. The data are tabulated by year and station number for each month, day, and event time (hh and mm). The volume collected in each event is under the column s-vol, and the total volume of rain collected from each day is found under the header "s-voltot"; both volumes are expressed in millilitres; the number of events each day is labelled "count." The standard precipitation gauge, as reported by the Atmospheric Environment Service of Downsview, Ontario, is labelled "aesrngg," and is reported in millimetres. The AES data were available up to and including June 1984.

The daily sampler efficiency,  $eff$ , is the ratio (expressed as a percentage) of the equivalent height of rain collected in the sampler ( $h$ ) to that in the standard rain gauge ( $g$ ). The collecting area,  $A$ , of the AOSERP sampler is  $1594 \text{ cm}^2$  (diameter 45 cm), hence the collection efficiency is

$$E = \frac{100 \times V}{p \times A}$$

where  $V$  is the volume of rain collected in millilitres,  $A$  is the collecting area of the sampler in square centimetres, and  $p$  is the standard rain gauge measurement in centimetres.

It should be stressed that the underlying assumption is that both samplers collected over the entire day and therefore sampler end times are ignored.

In this regard, while all data for June 1984 had been arbitrarily assigned start and/or end times (day and hour), such times were not recorded in the raw data files provided. The individual efficiencies calculated will not accurately reflect the day of

the month. The daily efficiencies show considerable variability and indicate over collection as well as poor collection efficiency. The former may be due to incorrect record of times or volumes, while the latter may be due to operator error in not opening the collector, missed events (at night), or unusual meteorological or site-specific factors. Monthly efficiencies are shown in Tables 40 and 41. The monthly sampling efficiencies are variable, but Birch Mountain (5), Ells Tower (15), and Bitumount Tower (32) had more consistent though low collection efficiencies. In contrast, Muskeg Mountain (47), Legend Tower (41), and Richardson (77) have poor efficiencies, and may reflect site-specific problems.

The distribution of monthly sampling efficiencies is such that 46 values were less than 50%, 34 were between 50 and 75%, and 32 were greater than 75%. Thus, for only less than 30% of the time was the collection efficiency near the acceptable range of efficiencies.

Monthly efficiencies for the 1983 precipitation survey are given in Table 42. The individual efficiencies calculated apply to the Sandalta (95) station, where a standard rain gauge was not recorded by the Atmospheric Environment Service but rather a comparison of the AOSERP sampler collection to that of the AOSERP tipping bucket rain gauge was made.

In general, the collection efficiencies are poor — often low and variable both within sites and between sites. The reason for the poor efficiencies is understandable due to the manner in which the samplers were operated. Thus, exposure for the entire event likely did not occur and, since samplers were not operated at night, most night events would have gone uncollected. In the absence of detailed data that include the times at which the standard rain gauge recorded data, further analysis of the daily collection efficiencies is not possible.

It should be noted also that apparently no AOSERP study was performed in order to characterize the sampler collection efficiency.

In view of the poor collection efficiencies, the estimation of wet deposition is inappropriate and would contain serious errors.

Table 40. Monthly efficiencies for rain samplers in the AOSERP summer precipitation network.

Year	Station	Month	Tots_vol	Sum_aesrngg	Eff
81	5	5	38.7	29.0	8.4
		6	7619.0	1007.0	47.6
		7	7348.0	375.0	123.2
		8	3499.0	260.0	84.6
		9	382.0	40.0	60.0
	6	5	304.6	36.0	53.2
		6	1930.0	255.0	47.6
		7	2957.0	313.0	59.4
	15	8	1624.0	188.0	54.3
		5	977.8	71.0	86.6
		6	9658.0	854.0	71.1
	28	7	7693.0	555.0	87.2
		8	122.0	79.0	9.7
		9	90.0	14.0	40.4
		5	1367.0	170.0	50.6
		6	1991.0	192.0	65.2
	29	7	8852.0	812.0	68.5
		8	2104.0	125.0	105.8
		5	403.0	70.0	36.2
		6	988.0	148.0	42.0
	32	7	2840.0	226.0	79.0
8		1608.0	163.0	62.0	
9		517.0	58.0	56.0	
5		321.8	48.0	42.2	
6		896.0	388.0	14.5	
34	7	388.0	27.0	90.4	
	8	41.0	7.0	36.8	
	9	588.0	47.0	78.7	
	5	263.0	78.0	21.2	
35	6	1609.0	416.0	24.3	
	7	7496.0	1556.0	30.3	
	5	884.7	116.0	48.0	
41	6	3300.0	644.0	32.2	
	7	5482.0	485.0	71.1	
	8	782.0	52.0	94.6	
	5	908.3	151.0	37.8	
47	6	691.0	170.0	25.6	
	7	2275.0	497.0	28.8	
	5	4.7	12.0	2.5	

continued ...

Table 40. Continued.

Year	Station	Month	Tots_vol	Sum_aesrngg	Eff	
81	47	6	1787.0	365.0	30.8	
		7	2547.0	804.0	19.9	
		8	215.0	159.0	8.5	
	51	5	377.4	6.0	395.5	
		6	16392.3	1096.0	94.0	
	77	5	522.2	63.0	52.1	
		6	2093.0	272.0	48.4	
		7	3305.0	542.0	38.3	
	115	8	6	61.0	20.0	19.2
			5	27.7	2.0	87.1
			6	2243.0	211.0	66.8
		7	7	7408.0	1249.0	37.3
8			155.0	105.0	9.3	
9			4116.0	206.0	125.6	
82	5	5	4361.0	307.0	89.3	
		6	183.0	9.0	127.9	
		7	1340.0	139.0	60.6	
		8	10980.0	913.0	75.6	
		9	3120.0	240.0	81.7	
		5	2301.0	627.0	23.1	
	15	6	3968.0	287.0	86.9	
		7	2257.0	489.0	29.0	
		8	1004.0	147.0	42.9	
	28	5	1162.0	244.0	29.9	
		6	1624.0	312.0	32.7	
		7	4149.0	716.0	36.4	
	29	8	8	8825.0	843.0	65.8
			5	647.0	133.0	30.6
		6	4204.0	365.0	72.4	
		7	4168.0	318.0	82.4	
		8	1867.0	447.0	26.3	
	32	9	895.0	194.0	29.0	
5		664.0	60.0	69.6		
6		1502.0	101.0	93.5		
7		8640.0	495.0	109.7		
34	8	8	3668.0	255.0	90.4	
		5	1393.0	121.0	72.4	
	6	6400.0	450.0	89.4		
	7	16851.0	1581.0	67.0		

continued ...

Table 40. Concluded.

Year	Station	Month	Tots_vol	Sum_aesrngg	Eff	
82	34	8	3198.0	291.0	69.1	
		9	877.0	70.0	78.8	
	35	5	968.0	88.0	69.2	
		6	212.0	32.0	41.7	
		7	3932.0	720.0	34.3	
		8	1584.0	242.0	41.2	
		9	788.0	70.0	70.8	
	41	5	1446.0	438.0	20.8	
		6	1180.0	105.0	70.7	
		7	2700.0	448.0	37.9	
	47	8	3193.0	458.0	43.8	
		5	3357.0	243.0	86.9	
		6	4238.0	259.0	102.9	
		7	7304.0	833.0	55.1	
	115	8	6	11811.0	839.0	88.5
			7	1217.0	162.0	47.2
		6	4291.0	357.0	75.6	
			3802.0	450.0	53.1	
			9453.0	647.0	91.9	
439.0			147.0	18.8		
84	5	6	11035.0	876.0	79.2	
	6	6	10191.0	450.0	142.4	
	15	6	5610.0	60.0	587.9	
	28	6	9252.0	2028.0	28.7	
	29	6	1786.0	285.0	39.4	
	32	6	16488.0	1196.0	86.7	
	34	6	12975.0	2754.0	29.6	
	35	6	5595.0	119.0	295.6	
	41	6	22394.0	1404.0	100.3	
	47	5	500.0	195.0	16.1	
		6	25146.0	3320.0	47.6	
	77	6	9912.0	592.0	105.3	
	115	5	12200.0	1100.0	69.7	
		6	44865.0	4542.0	62.1	



Table 41. Sample calculation of sampler collection efficiency.

Sampling Date	Site Identification	AOSERP Rain Volume (mL) (given)	AOSERP Rain Volume (mm <sup>3</sup> ) (calculated)	Area of the AOSERP Rain Sampler (mm <sup>2</sup> ) (calculated)	AOSERP Height of Rain (mm) (calculated)	Standard Rain Gauge (mm) (given)	Ratio (AOSERP Standard) (calculated)	Average Percentage of Rain Collected by AOSERP
May 17/81	Birch Mountain	11.7	11 700	159 013	0.000 7	2.3	0.03	1981 9%
Jun 27/81	Birch Mountain	232	232 000	159 013	0.015	7.2	0.2	
Sep 01/81	Birch Mountain	382	38 200	159 013	0.002	4.0	0.05	
Jun 04/82	Ells Lookout	34	34 000	159 013	0.002 1	0.6	0.4	1982 47%
Jul 22/82	Thickwood	2 530	2 530 000	159 013	0.159	26.9	0.6	
Aug 04/82	Legend Lookout	673	673 000	159 013	0.042	11.5	0.4	
May 31/84	Thickwood	6 025	6 025 000	159 013	0.379	55.0	0.6	1984 67%
Jun 19/84	Bitumount	1 020	1 020 000	159 013	0.064	7.9	0.8	
Jun 19/84	Stony Mountain	1 015	1 015 000	159 013	0.064	10.9	0.6	

Equations: Area =  $\pi r^2$ , r = radius of the sampler  
 Volume = height x area  
 Height = volume ÷ area  
 Conversion units 1 mL = 1 cm<sup>3</sup> = 1000 mm<sup>3</sup>

Table 42. Monthly efficiencies for rain samplers located at the Sandalta station, 1983.

Month	Total Rain Collected <sup>a</sup> (mL)	Total Rain Gauge (Tipping Bucket) (mm)	Efficiency (%)
July	3919	68.6	36
August	2813.1	18	98
September	365	13.2	17

<sup>a</sup> Daytime collection only.

The data would likely provide an underestimate of wet deposition. In addition, if the precipitation chemistry changed during an event (e.g., higher concentrations at the start of the event) and the extent to which events were sampled is uncertain (sampler exposed always for start of event), then the calculation of volume weighted mean concentrations also will be very unreliable.

#### 4.3.2 Winter Thaw Periods

The occurrence of thaw (above freezing temperatures) periods three to four weeks prior to or during snowcore sampling may affect sample integrity because of the potential for leaching of pollutants from the sample (Johannessen, 1978). In such cases, inferences based on analyses of such samples may be distorted.

There are many factors to be considered when determining whether a thaw period is significant. These include:

1. Consecutive daily maximum and minimum temperatures,
2. The length of time in terms of hours or days for which temperatures are significantly greater than 0°C,
3. The depth and type of snow at the time the thaw occurred, and
4. The level and degree of precipitation.

After such a review, it is still difficult to determine the degree of evaporation, chemical redistribution, or leaching of pollutants that may have occurred in the snowpack at a particular site. This type of assessment should be completed at the time and place of the study.

Daily temperature data at stations in the study area (available from the Canadian Climatological Digital Archive) were obtained and analysed to assess the potential for the influence of thaw periods. Table 43 summarizes the number of days on which the temperatures were above zero four weeks prior to each sampling period. (Note: These days may or may not imply a change in the chemical composition of the snow, and should be used only as a guide to potential problems.)

Table 43. AOSERP winter thaw periods.

Date of Sampling Period	Station Name	Average Temperature During the Sampling Period (°C)	Number of Days with Temperatures Greater Than Zero Four Weeks Prior to the Sampling Period	Comments
3 to 9 March 1976	Fort McMurray	- 5.2	2	Potential Problems
	Mildred Lake	- 5.48	5	Potential Problems
25 to 28 January 1978	Fort McMurray	-19.7	Nil	No Problems
	Mildred Lake	-19.8	Nil	Anticipated
10 to 13 January 1981	Fort McMurray	- 0.55	5	Slight Potential Problems
	Mildred Lake	- 1.0	3	
20 to 23 February 1981	Fort McMurray	2.3	8	Potential Problems
	Mildred Lake	- 1	8	
15 to 19 February 1983	Fort McMurray	-11	2	Potential Problems
	Mildred Lake	Data Not Available		
21 to 24 March 1983	Fort McMurray	Data Not Available		
	Mildred Lake			
23 to 27 January 1984	Fort McMurray	8.8	5	Potential Problems
	Mildred Lake			
16 to 20 February 1984	Fort McMurray	6.6	13	Hazard
	Mildred Lake	Data Not Available		
15 to 19 March 1984	Fort McMurray	4.9	10	Hazard
	Mildred Lake	Data Not Available		

Note: Weather information was available for review from only two representative sites: Fort McMurray and Mildred Lake.

From Table 43, the sampling periods of 1978 were not likely affected by the problems of winter thaw, since there were no days with temperatures above zero for a least four weeks prior to sampling. The sampling periods of February and March 1984, however, may have been seriously affected by the thaw.

All other snowcore sampling surveys may be considered unlikely to have been affected by leaching due to thaw periods.

It should be noted that such evidence is inconclusive. However, it is an important aspect that should be considered in the timing of future snowcore studies as well as in the assessment of the sample representativeness of historical data.

#### 4.3.3 Blank Samples

For this study, a blank sample is defined as a deionized water sample prepared and handled as though it were a real sample, and subjected to the usual analytical measurement processes. Such samples establish a baseline (background value) or identify various types of biases or random contamination problems that may have occurred.

Blank sample information was available only for one special study carried out in the summer of 1983. Two blank samples were prepared for this study: one sample was analysed by the Alberta Environmental Centre (AEC) laboratory, Vegreville, and the other by the Kananaskis laboratory. Each laboratory analysed their (one) sample several times, and the mean values and relative standard deviations are given in Table 44. The Kananaskis laboratory, on average, had more data variability among replicate results than did the Alberta Environmental Centre (AEC) laboratory. However, in order to identify which parameters may have been victims of random contamination, the mean-blank values of both laboratories were averaged to generate a composite blank mean concentration value. Table 45 summarizes, by parameter, the 1983 sample mean concentration values and the relative standard deviations in comparison to the 1983 blank mean concentration values and their corresponding relative standard deviations. The reproducibility of the blanks for all parameters was poor

Table 44. Blank data, 1983.

Parameter <sup>a</sup>	LABORATORY 1 (AES)				LABORATORY 2 (KANANASKIS)			
	Number of Duplicate Results	Mean Value <sup>a</sup>	Standard Deviation of Duplicate Results	Relative Standard Deviation (%)	Number of Duplicate Results	Mean Value <sup>a</sup>	Standard Deviation of Duplicate Results	Relative Standard Deviation (%)
pH	4	5.9	0.071	1.2	13	5.89	0.024	4
NH <sub>4</sub> <sup>+</sup>	2	0.04	0.02	50	13	0.023	0.023	100
Ca <sup>2+</sup>	2	0.005	0.0	0	11	0.003	0.035	120
K <sup>+</sup>	2	0.008	0.003	33.3	13	0.161	0.426	264
Na <sup>+</sup>	2	0.045	0.005	11.1	13	0.076	0.123	162
Mg <sup>2+</sup>	2	0.05	0.00	0	11	0.005	4.6 x 10 <sup>-8</sup>	0.01
Specific conductivity	4	2.49	0.239	9.6	13	3.5	2	57
Cl <sup>-</sup>	3	0.037	0.031	83.8	-	-	-	140
SO <sub>4</sub> <sup>2-</sup>	3	0.022	0.012	55	13	0.081	0.113	0
PO <sub>4</sub> <sup>3-</sup>	3	0.010	0.007	71	10	0.005	0.00	85
NO <sub>3</sub> <sup>-</sup>	3	0.017	0.017	97.1	13	0.013	0.011	-
Ti	4	0.127	0.038	29.9	1	0.047	-	-
Si	4	0.197	0.042	21.3	1	0.104	-	-
S	4	0.461	0.148	32	1	0.255	-	-
Fe	3	0.117	0.022	18.7	1	0.035	-	-
Al	4	0.562	0.180	32	1	0.416	-	-
Average RSD				35.1 ±30.7				66.6 ±82.5

<sup>a</sup> All concentrations in mg·L<sup>-1</sup> except for pH, which is in pH units.  
 - No data available

Table 45. Blank samples, 1983.

Parameter	Detection Limit (mg•L <sup>-1</sup> )	Sample Mean (mg•L <sup>-1</sup> )	Relative Standard Deviation (%)	Blank Mean (mg•L <sup>-1</sup> )	Relative Standard Deviation (%)	Concentration Comparison [Blank] / [Sample] x 100 (%)
NH <sub>4</sub> <sup>+</sup>	0.02	0.102	2.3	0.032	38	31.0
NO <sub>3</sub> <sup>-</sup>	0.02	0.676	0.9	0.015	20	2.2
PO <sub>4</sub> <sup>3-</sup>	0.02	0.065	0.0	0.008	50	12.3
SO <sub>4</sub> <sup>2-</sup>	0.02	0.664	0.9	0.05	84	7.5
Ca <sup>2+</sup>	0.02	0.047	6.2	0.017	0	36.0
Cl <sup>-</sup>	0.02	0.327	3.4	-	-	-
K <sup>+</sup>	0.02	0.906	1.2	0.084	131	9.0
Na <sup>+</sup>	0.02	0.106	2.4	0.061	33	6.1
Mg <sup>2+</sup>	0.02	0.024	7.3	0.005	0	20.4

- No data available

in comparison to the samples. However, for such low concentrations, it is not unusual that the relative standard deviation is greater than 50%, especially since the value approaches the analytical detection limit. Also, when the blank mean concentration values approach 10% of the sample mean concentration values, there should be a laboratory review for potential identification of random sources of contamination, and appropriate sample correction action should be taken.

In 1983, four of the eight parameters reviewed, namely  $\text{NH}_4^+$ ,  $\text{PO}_4^{3-}$ ,  $\text{Ca}^{2+}$ , and  $\text{Mg}^{2+}$ , had blank concentration values greater than 10% of the sample concentration values.

Possible sources of contamination could be:

1. dust in the sample containers,
2. residue acids used in the cleaning process,
3. contaminated deionized water, and
4. contamination from analyst.

The sources of contamination are difficult to identify. However, to better ensure the sample integrity, every lab (for every set of analyses) should run several blank samples. In addition, with every new batch of sampling bags or bottles, a special quality control study should be completed, as suggested in Table 15.

#### 4.3.4 Laboratory Duplicate Data

Precision refers to the reproducibility of a measurement technique when it is repeated on a homogeneous sample under controlled conditions.

Within each run (or after a given number of samples), the laboratory analyst should repeat (non-consecutively) an earlier analysis of a real precipitation sample to determine the reproducibility of the result. Standard deviation values from within-run duplicates are used to estimate the within-run precision or the daily analyst's sample handling variability on a day-to-day basis.

The standard deviation of duplicate results for a particular parameter is given by the equation:



$$\text{Standard Deviation} = \left[ \frac{\sum_{n=1}^N D^2}{2N} \right]^{1/2} \quad (\text{Equation 1})$$

where  $\sum_{n=1}^N D^2$  is the summation of all the differences of the duplicate results squared.

$$\text{I.e.,} \quad D = (X_{A_1} - X_{A_2})^2 + (X_{B_1} - X_{B_2})^2 + \dots$$

$X_{A_1}$  = duplicate result 1 of sample A for parameter X by laboratory 2

$X_{A_2}$  = duplicate result 2 of sample A for parameter X by laboratory 2

$X_{B_1}$  = duplicate result 1 of sample B for parameter X by laboratory 2

$X_{B_2}$  = duplicate result 2 of sample B for parameter X by laboratory 2

N = the total number of duplicate results

A measure of precision also can be calculated as the standard deviation of a set of values divided by the mean value and multiplied by 100. This represents the "relative standard deviation" as a percentage.

$$\text{Relative Standard Deviation (RSD)} = \frac{\text{Standard Deviation}}{\text{mean}} \times 100 \quad (\text{Equation 2})$$

Section 8.11 summarizes, by year, the mean values, standard deviations, and relative standard deviations for all parameters analysed for both the summer and winter precipitation studies. There were no duplicate results available for review for any summer precipitation studies prior to 1981, nor for any winter precipitation study prior to 1984!

As a guideline for environmental samples, a relative standard deviation of 5 to 20% for replicate samples is not unusual, less

than 5% is excellent, and greater than 50% is an indication of poor laboratory handling (for parameters that are well above the detection limit). Tables 46 and 47 classify each parameter by the range of its calculated relative standard deviation. This allows the data user to observe the problem areas within any one year. For example, in 1981 duplicate results for Mn, A, V and Na were extremely variable, and should be flagged by the analyst and data user. Generally, the duplicate results were reasonable for all years, winter or summer.

It is recommended that the data in Tables 46 and 47 not be compared among parameters between years, or for that matter within years, unless the number of duplicate results are equal and the number and type of monitoring stations and methods are similar.

Comparisons could be made using the heteroscedastic paired t-test using the appropriate standard deviations and t value from standard statistical tables for the desired level of confidence. Given the variability in network protocols over the years and other changes, this was considered unwarranted. The variability could also be tested to determine whether differences in the standard deviations were meaningful. This can be performed by use of the F test on the variance. This test determines whether precision estimates, in different years for the same parameter, were significantly different, and the level of confidence at which the precision is different for each of the analysed compounds.

Poor agreement between duplicate results may indicate that the laboratory sample handling practices lacked control, thus it is important that duplicate analyses are reviewed immediately (i.e., both within run and between run) to facilitate immediate corrective action. Review of duplicate results long after the analysis is complete may show surprising results to the data user, and will not inspire confidence in the validity of each sample.

#### 4.3.5 Replicate Results

Individual samples collected from the same sampling site with the same sampler are referred to as replicate samples. This precision estimate gives the aggregate variability introduced by the

Table 46. Relative standard deviations for selected parameters monitored in AOSERP summer precipitation studies.

Study Year	RSD 0%	RSD < 5%	RSD 5 to 20%	RSD 20 to 50%	RSD > 50%	RSD > 100%
1981	Be, Cr, Cu, Ti, Co, K <sup>+</sup> , Mo, Ni, Pb Sn, Sr		Cd, Cl <sup>-</sup> , Na <sup>+</sup>			Mn <sup>2+</sup> , Al <sup>-</sup> , V, Na <sup>+</sup>
1982		pH, F <sup>-</sup> , Specific Conductivity	NH <sub>4</sub> <sup>+</sup> , SO <sub>4</sub> <sup>2-</sup> NO <sub>3</sub> <sup>-</sup> , Ca <sup>2+</sup> , K <sup>+</sup> Cl <sup>-</sup> , Mg <sup>2+</sup>		Na <sup>+</sup> , K <sup>+</sup> , PO <sub>4</sub> <sup>3-</sup>	
1983			pH, NH <sub>4</sub> <sup>+</sup> , NO <sub>3</sub> <sup>-</sup> PO <sub>4</sub> <sup>3-</sup> , SO <sub>4</sub> <sup>2-</sup> , Cl <sup>-</sup> , K <sup>+</sup> , Na <sup>+</sup> , Specific Conductivity	Ca <sup>2+</sup> , Mg <sup>2+</sup>		
1984			NO <sub>3</sub> <sup>-</sup> , SO <sub>4</sub> <sup>2-</sup>	PO <sub>4</sub> <sup>3-</sup> , Na <sup>+</sup>	NH <sub>4</sub> <sup>+</sup> , Ca <sup>2+</sup> , Cl <sup>-</sup> , K <sup>+</sup> , Mg <sup>2+</sup>	NO <sub>2</sub> <sup>-</sup>

Table 47. Relative standard deviations for selected parameters monitored in AOSERP winter precipitation studies.

Study Year	RSD 0%	RSD < 5%	RSD 5 to 20%	RSD 20 to 50%	RSD > 50%	RSD > 100%
1984		$\text{PO}_4^{3-}$ , $\text{SO}_4^{2-}$ Li, Co, Cr, K, Mo, Ni, P, Pb, Sb, Se, Si, Th, Ti, U, Zr, Al, As, B, Be, Bi, Cd		Mn, Sr, Ba, $\text{Ca}^{2+}$ , Fe, Alkalinity	$\text{Na}^+$ , Zn, Cu, $\text{Cl}^-$	$\text{NO}_2^-$

field sampling and handling procedures in addition to the laboratory protocols.

The calculated mean and standard deviation values for replicate results are tabulated in Section 8.12 for both the summer and winter precipitation studies (see equations 1 and 2 of Section 4.3.4).

The results of replicate samples have been reviewed for each year, and the parameters with a relative standard deviation greater than 20% identified. Tables 48 and 49 outline, by year, the three parameters with the highest degree of variability among replicate samples and the three parameters with the best agreement among replicate samples. Accordingly,  $\text{Na}^+$  seems to be the "problem" parameter, and pH the most consistent parameter, for both the summer and winter surveys.

It is surprising that the problem parameter is  $\text{Na}^+$  for all AOSERP surveys, summer and winter, especially in view of the fact that different organizations performed the sampling and analysis from year to year.

In addition, the use of different types of equipment from one year to the next, as well as differences in the number of sampling sites, make the source of the high variability in  $\text{Na}^+$  data difficult to resolve.

As far as the implication of analytical procedures for the source of the inconsistent  $\text{Na}^+$  data is concerned, it should be noted that most laboratories analysed  $\text{Na}^+$  either by atomic absorption spectrophotometry or by ion-chromatography simultaneously with  $\text{K}^+$  and  $\text{Ca}^{2+}$ . Therefore, it seems unlikely that  $\text{Na}^+$  would be analytically out of control, while the other parameters, run simultaneously, were in control. However, sodium is ubiquitous and may very easily be subject to contamination from several sources.

It should be noted also (see data in Section 8.12) that within any single year, the degree of variability among replicate results is extremely irregular, which may be a reflection of random field sampling inconsistencies.

Table 48. Replicate results for the summer precipitation program.

Year	Three Worst Parameters	Three Best Parameters	Range of Relative Standard Deviation
1976	$\text{Ca}^{2+}$ , $\text{Na}^+$ , $\text{NH}_4^+$	$\text{PO}_4^{3-}$ , pH, $\text{NH}_4^+ - \text{N}$	0 to 98%
1977	$\text{K}^+$ , $\text{Na}^+$ , $\text{Mg}^{2+}$	pH, $\text{NH}_4^+$ , $\text{NH}_4^+ - \text{N}$	3.9 to 148.5%
1978	pH, alkalinity, $\text{Na}^+$	$\text{Ca}^{2+}$ , $\text{Cl}^-$ ; $\text{Mg}^{2+}$ ; $\text{SO}_4^{2-} - \text{S}$ , $\text{K}^+$	0 to 149%
1979	$\text{Cl}^-$ , $\text{NH}_4^+$ , $\text{NH}_4^+ - \text{N}$	alkalinity, pH, $\text{Ca}^{2+}$	0 to 86%
1981	$\text{PO}_4^{3-}$ , specific conductivity, $\text{Na}^+$	pH, $\text{Ca}^+$ , $\text{SO}_4^{2-}$	1.8 to 136%
1982	$\text{PO}_4^{3-}$ , specific conductivity, pH	$\text{F}^-$ , $\text{Mg}^{2+}$ ; pH; $\text{Ca}^{2+}$	0 to 99%
1983	Br, $\text{PO}_4^{3-}$ , $\text{Na}^+$	pH, $\text{NO}_3^-$ , $\text{SO}_4^{2-}$	1.9 to 125%
1984	$\text{Mg}^{2+}$ , $\text{Ca}^{2+}$ , $\text{K}^+$	$\text{PO}_4^{3-}$ , acidity, pH	0 to 170%

Table 49. Replicate results for the winter precipitation program.

Year	Three Worst Parameters	Three Best Parameters	Range of Relative Standard Deviation
1976	specific conductivity	pH	1 to 74% (only three parameters analysed)
1977	NIL	NIL	NIL
1978	$K^+$ , $Na^+$ , $NH^+ - N$	pH, $SO_4^{2-}$ , $NO_3^{2-}$	6 to 66%
1979	NIL	NIL	NIL
1981	alkalinity, $Cl^-$ , $Na^+$	$NO_3^-$ , pH, $K^+$	0.1 to 131%
1982	NIL	NIL	NIL
1983	$Na^+$ , $K^+$ , $Ca^{2+}$	$F^-$ , pH, $NO_3^-$	0 to 267%
1984	$NO_2^-$ , $SO_4^{2-}$ , $Cl^-$	metals, pH, $PO_4^{3-}$	

#### 4.3.6 Co-located Sampling

Data gathered in a special summer precipitation study undertaken in 1983 were reviewed to examine the site/sample precision (including instrument, operator, shipping, and laboratory precision factors). The data from co-located samplers were reviewed for this purpose.

Co-located samples are defined as two separate precipitation samples collected simultaneously in two identical samplers located at the same sampling site. Since both samplers collect rain from the same event, the samples should have the same chemical composition. The concentration data generated from the pair of samplers, the 5000 series analysed at the Kananaskis Center for Environmental Research and the 6000 series analysed by the Alberta Environmental Centre, are compared by means of 1:1 plots for each parameter studied, and are presented in Section 8.14.

Each plot contains concentration data ( $\text{mg}\cdot\text{L}^{-1}$ ) for sampler 5000 series on the x-axis and sampler 6000 series on the y-axis. If the concentration values of the two samples are identical, the graph will be a straight line with a slope of one, an intercept of zero, and a correlation coefficient of 1.0.

Each plot has the 1:1 line indicated to illustrate agreement between the data from each sampler.

Linear regressions of the data for each parameter were performed, and Table 50 summarizes the slope, intercept, and correlation coefficient for each parameter.

Based on the analysis of these data, the samplers and subsequent handling and analytical procedures provided reliable and consistent data for  $\text{SO}_4^{2-}$ -S,  $\text{NO}_3^-$ , specific conductance,  $\text{pH}$ ,  $\text{Ca}^{2+}$ , and  $\text{Mg}^{2+}$ . Relatively poorer consistency was obtained for  $\text{NH}_4^+$ ,  $\text{Cl}^-$ , and  $\text{Na}^+$ . The data appeared to be biased high in the case of 1 sampler (5000) for  $\text{Cl}^-$  and biased low for specific conductance.

As a result of the co-located sampling, the overall site/sample precision of the 1983 summer precipitation study is adequate; however, this may not apply to all the AOSERP data.



Table 50. Summer precipitation study correlation coefficients, 1983.

Parameters	Number of Co-located Samples	Correlation Coefficient	Slope	Intercept	Comments
NH <sub>4</sub> <sup>+</sup>	36	0.482	0.286	0.104	Random
SO <sub>4</sub> <sup>2-</sup> - S	36	0.983	0.884	0.139	Excellent
NO <sub>3</sub> <sup>-</sup>	36	0.988	0.916	0.010	Excellent
Cl <sup>-</sup>	36	0.446	0.608	0.030	Bias High
Na <sup>+</sup>	37	0.443	0.726	0.015	Fair
Specific Conductivity	40	0.966	0.89	-3.76	Slightly Bias Low
pH	40	0.926	1.21	-0.83	Good
Ca <sup>2+</sup>	36	0.933	1.03	0.025	Good
Mg <sup>2+</sup>	36	0.761	0.069	0.006	Slightly Random

It is for this reason that co-located samples should be a permanent feature of the AOSERP network (note: other networks have also included co-located sampling as an important quality control measure).

#### 4.3.7 Interlaboratory Studies

The analytical accuracy and precision of laboratories may be evaluated by means of interlaboratory comparison studies. These studies help to identify areas of systematic bias. Interlaboratory studies typically involve preparing a set of samples of a natural matrix, submitting them to a relatively large number of participating laboratories to be analysed in a routine manner, and receiving reports of the results from the laboratories. The reported results are analysed by the laboratory or agency co-ordinating or conducting the test program to determine the variation among the participating laboratories. Available information on the participation of laboratories analysing AOSERP samples indicated only infrequent participation in such studies. In addition, the data were poorly documented and in view of the inconsistent application of other QA/QC procedures, provide a very incomplete assessment of laboratory bias. The general lack of information precludes the assessment of the laboratories' performance as far as accuracy and systematic bias are concerned.

## 5. DATA ANALYSIS AND INTERPRETATION

### 5.1 INTRODUCTION

Screened data for rain and snow samples were analysed to establish temporal and spatial trends, to determine interrelationships between parameters, and to identify and characterize the synoptic scale meteorological features of episodic rain events or periods. This chapter presents the temporal and spatial analyses first for rain data (Section 5.2), then for snow (Section 5.3). The analyses presented in Sections 5.2 and 5.3 are in terms of concentrations in rain or snow as the case may be, since sample volume data were not always available together with concentration data. More importantly however, the relatively poor collection efficiencies of the rain collectors do not allow much confidence to be placed in the volume weighted data. Nevertheless, selected volume weighted concentration data are presented in a later Section (5.6), with a discussion of emission trends. The interrelationships between parameters, which included factor analyses for rain and snow data, are presented and discussed in Sections 5.4.1 and 5.4.2 for rain and snow respectively. Episodic rain events or periods are discussed in Section 5.5. The relationship between precipitation quality and industrial activities in the study area are examined in Section 5.6. These statistical analyses are not exhaustive in view of the lack of, or deficiencies in the data, but they address the major objectives indicated in the terms of reference.

### 5.2 STATISTICS ON RAIN DATA

#### 5.2.1 Temporal Trends

The temporal trends for selected parameters in the screened data are presented both on a network-wide basis and for selected stations. Annual frequency distributions and monthly means of the concentrations of selected parameters also are presented to illustrate these trends. Some corresponding volume weighted means are presented in Section 5.6.

5.2.1.1 Frequency distributions - box plots. For the frequency distributions, annual box plots on which the mean and various percentiles are indicated are presented. The key to these box plots is given in Figure 9 and box plots for the parameters  $H^+$ ,  $SO_4^{2-}$ ,  $NO_3^-$ ,  $Cl^-$ ,  $Ca^{2+}$ ,  $Mg^{2+}$ ,  $Na^+$ ,  $K^+$ ,  $NH_4^+$ , and conductance are presented in Figures 10 to 19. The ordinate in each plot is in milliequivalents/litre to provide direct comparisons of the relative importance of species.

In examining the box plots, it should be noted and stressed that in 1983, data were obtained for only one station, consequently network-wide trends are not indicated by this set of box plots. The presentation of these box plots is intended to provide a gross indication of the concentration ranges for selected pollutants over the study period. Since different numbers of stations were in operation each year, and different sampling and/or analytical protocols and laboratories also were applied for some years, it is not feasible to attempt a detailed analysis of trends for these data.

Bearing these factors in mind, the gross qualitative interferences evident in the plots are summarized below.

There is evidence of the mean concentrations increasing with time for sulphate, ammonium, and conductivity, but it is clear that the data overlap extensively, thus it is not feasible to determine if these trends are statistically significant. For these species, the variability in the data was larger in the later years as indicated by the ranges in the higher percentile concentrations.

The trends in sodium and chloride were similar in that there were generally increasing trends between 1976 and 1979, during which the data were more variable, and, after 1980, the concentrations were lower and less scattered. This may be evidence of operator-introduced contamination in the earlier years. Lower concentrations in and after 1981 also were shown by potassium and magnesium, but the concentrations in the earlier years were similar. The calcium concentrations were similar at least for the lower percentiles, although the higher percentiles varied by a factor of nearly 10 between the lowest and highest 99th percentile concentra-

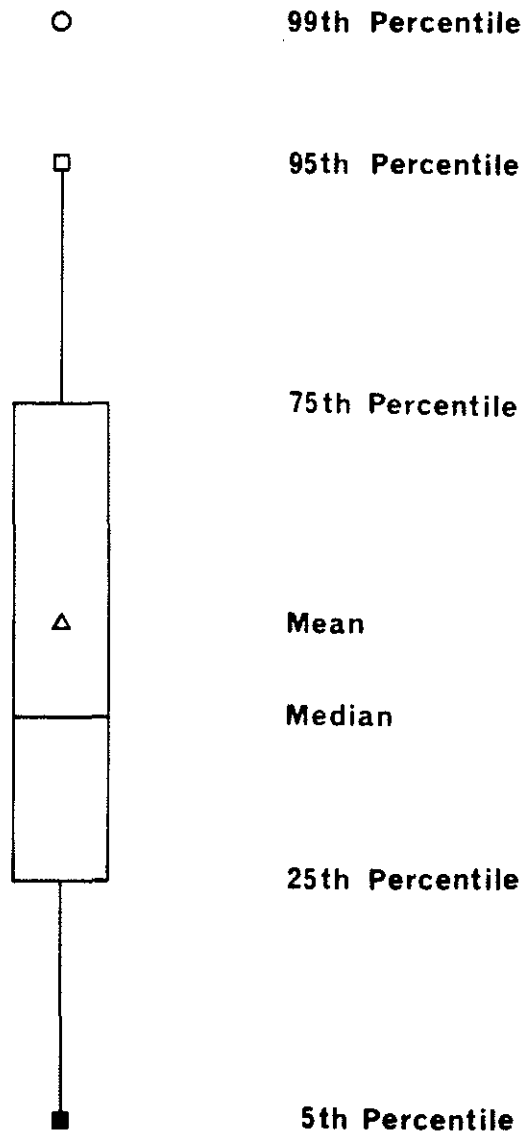

Figure 9. Key to box plots.

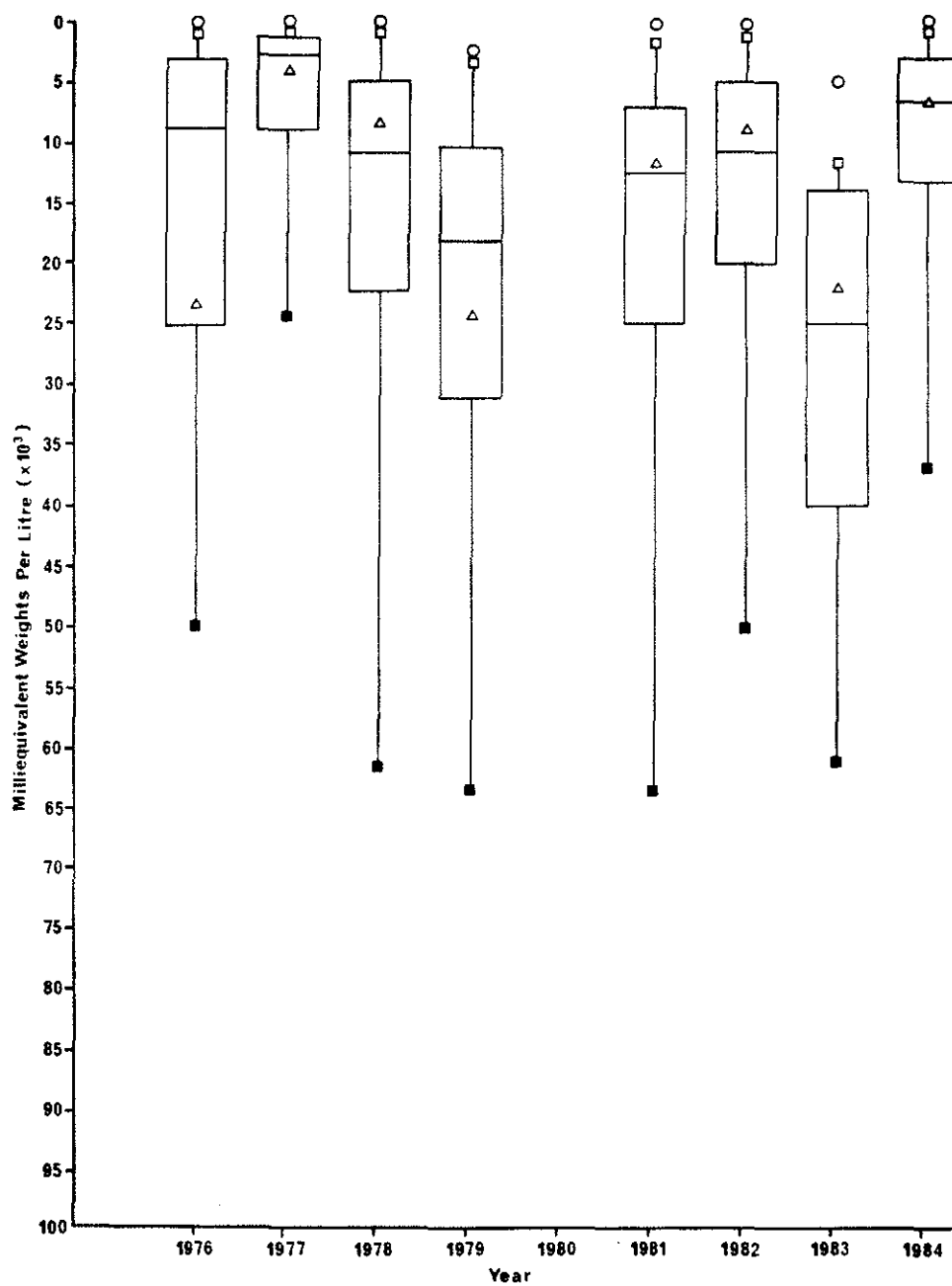

Figure 10. Box plots for the annual distribution of the hydrogen ion concentration in rain samples in the AOSERP network.

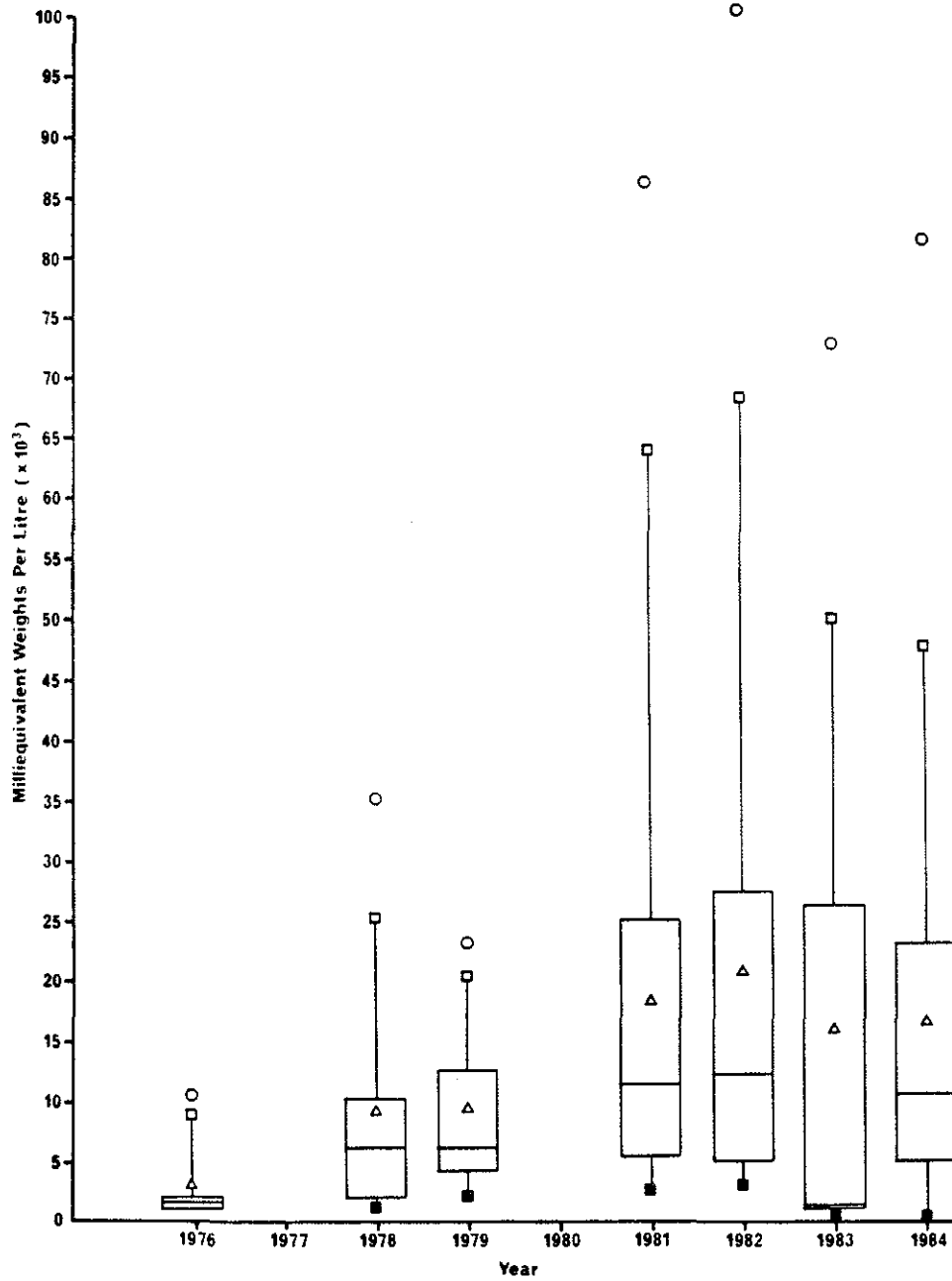

Figure 11. Box plots for the annual distribution of the sulphate ion concentration in rain samples in the AOSERP network.

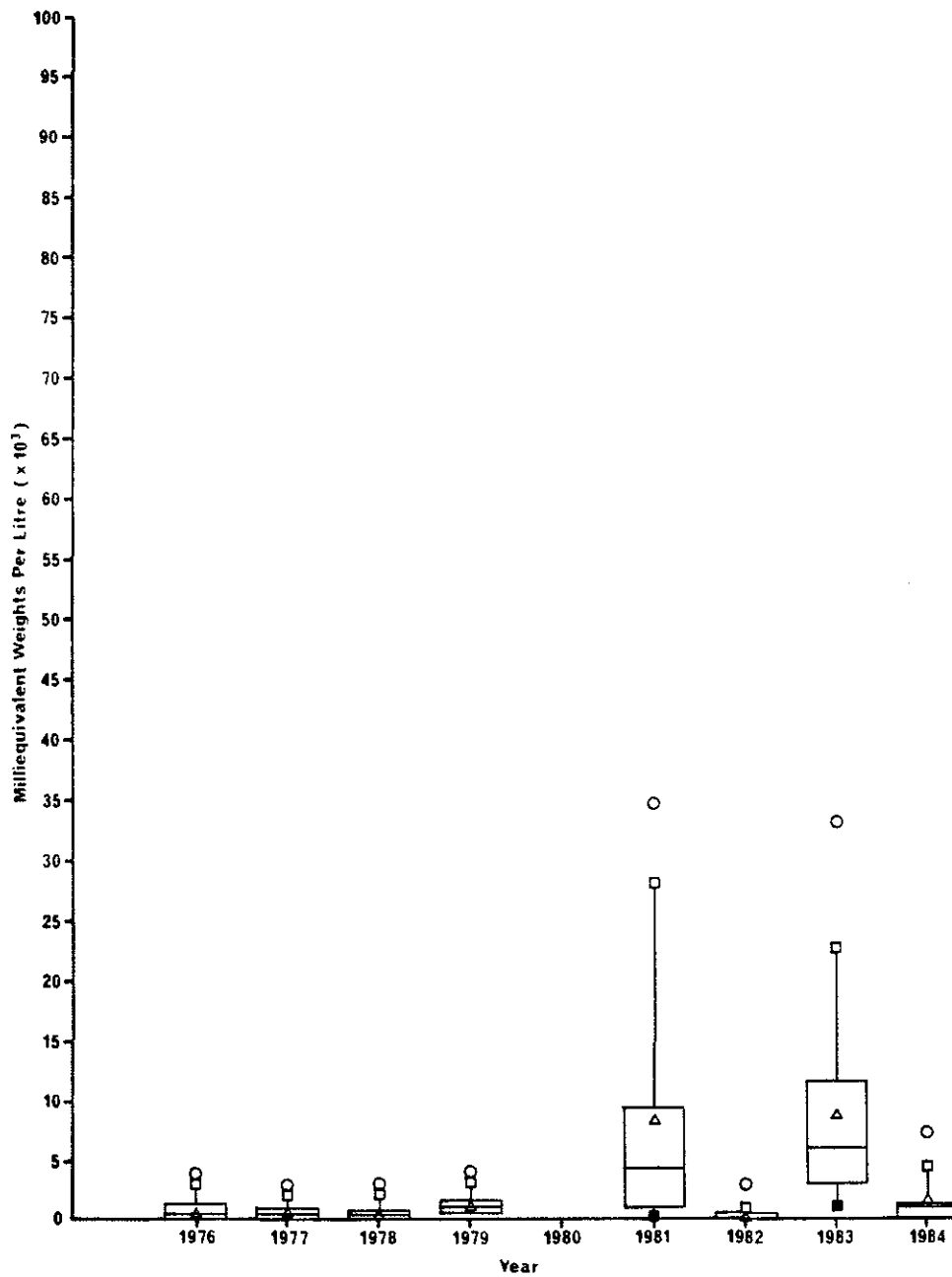

Figure 12. Box plots for the annual distribution of the nitrate ion concentration in rain samples in the AOSERP network.



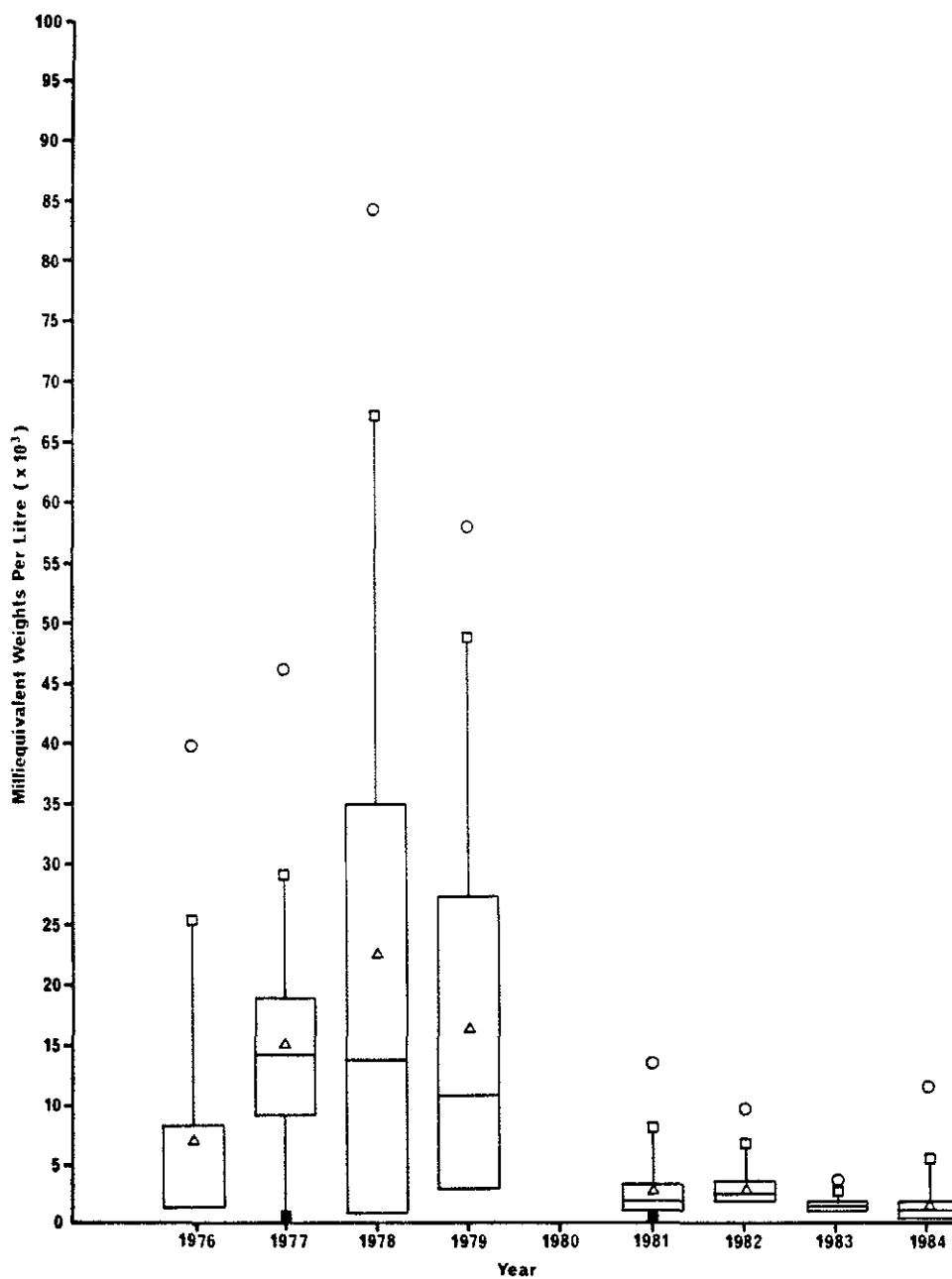

Figure 13. Box plots for the annual distribution of the chloride ion concentration in rain samples in the AOSERP network.

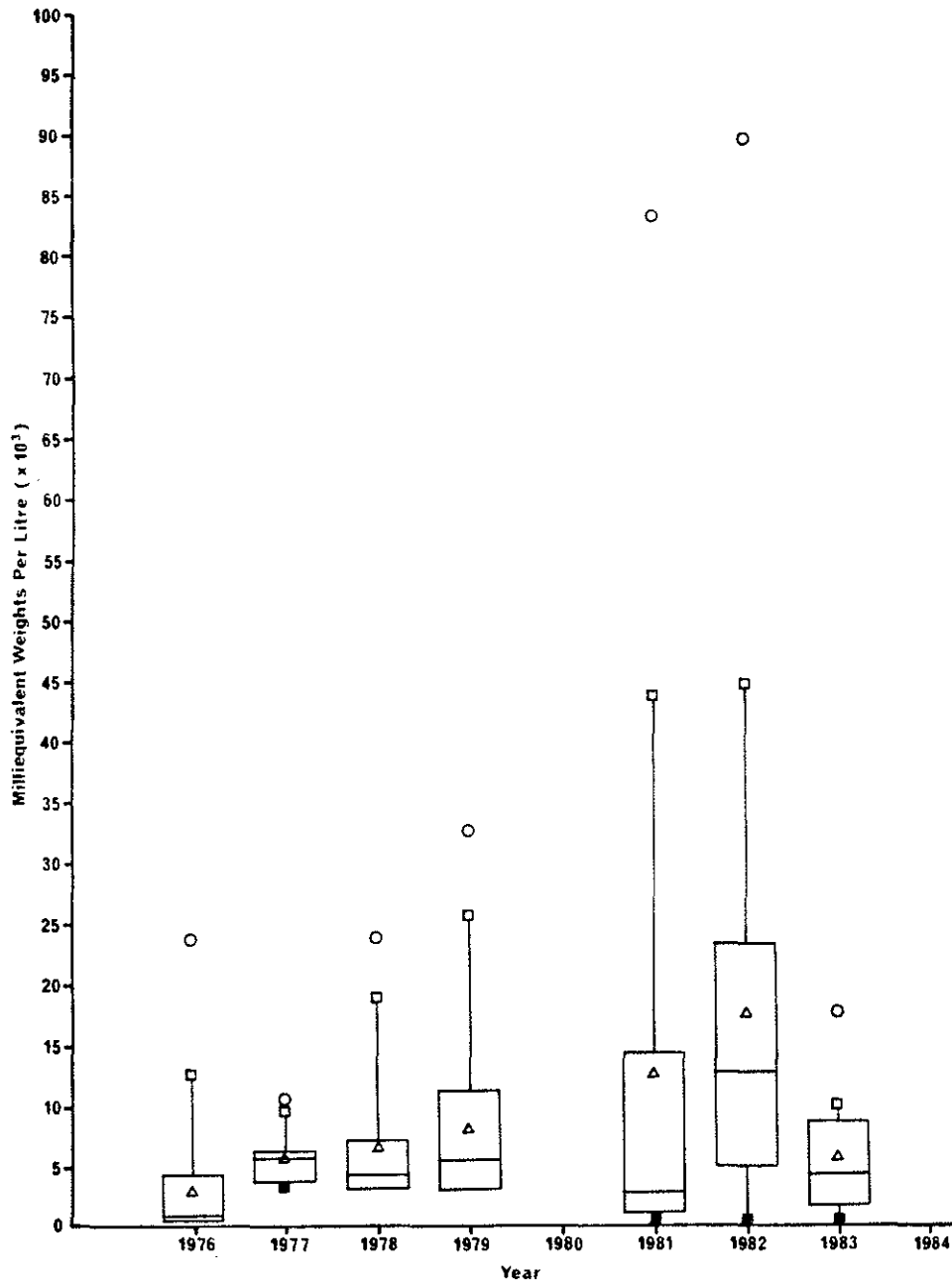

Figure 14. Box plots for the annual distribution of the calcium ion concentration in rain samples in the AOSERP network.

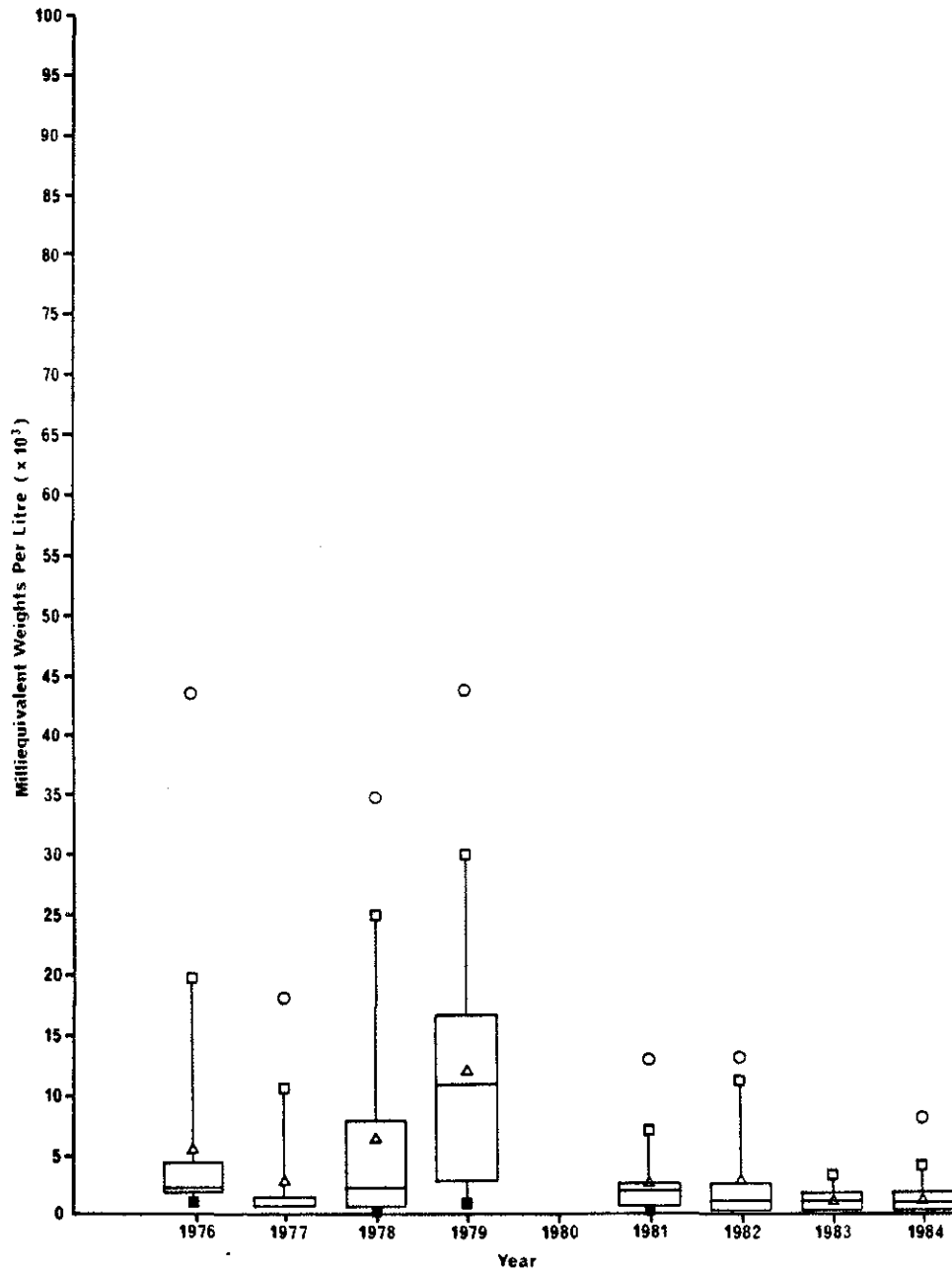

Figure 15. Box plots for the annual distribution of the magnesium ion concentration in rain samples in the AOSERP network.

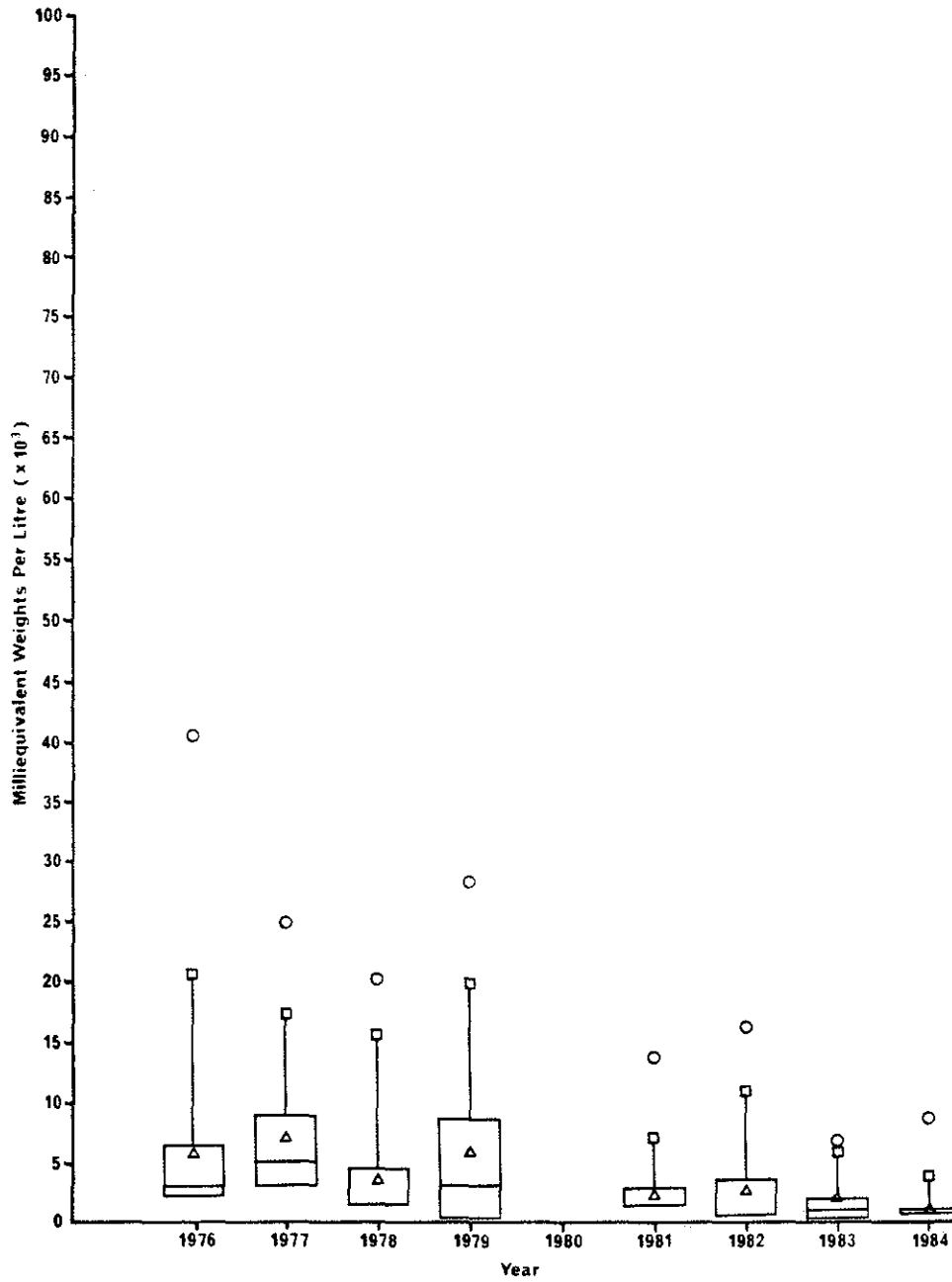

Figure 16. Box plots for the annual distribution of the sodium ion concentration in rain samples in the AOSERP network.

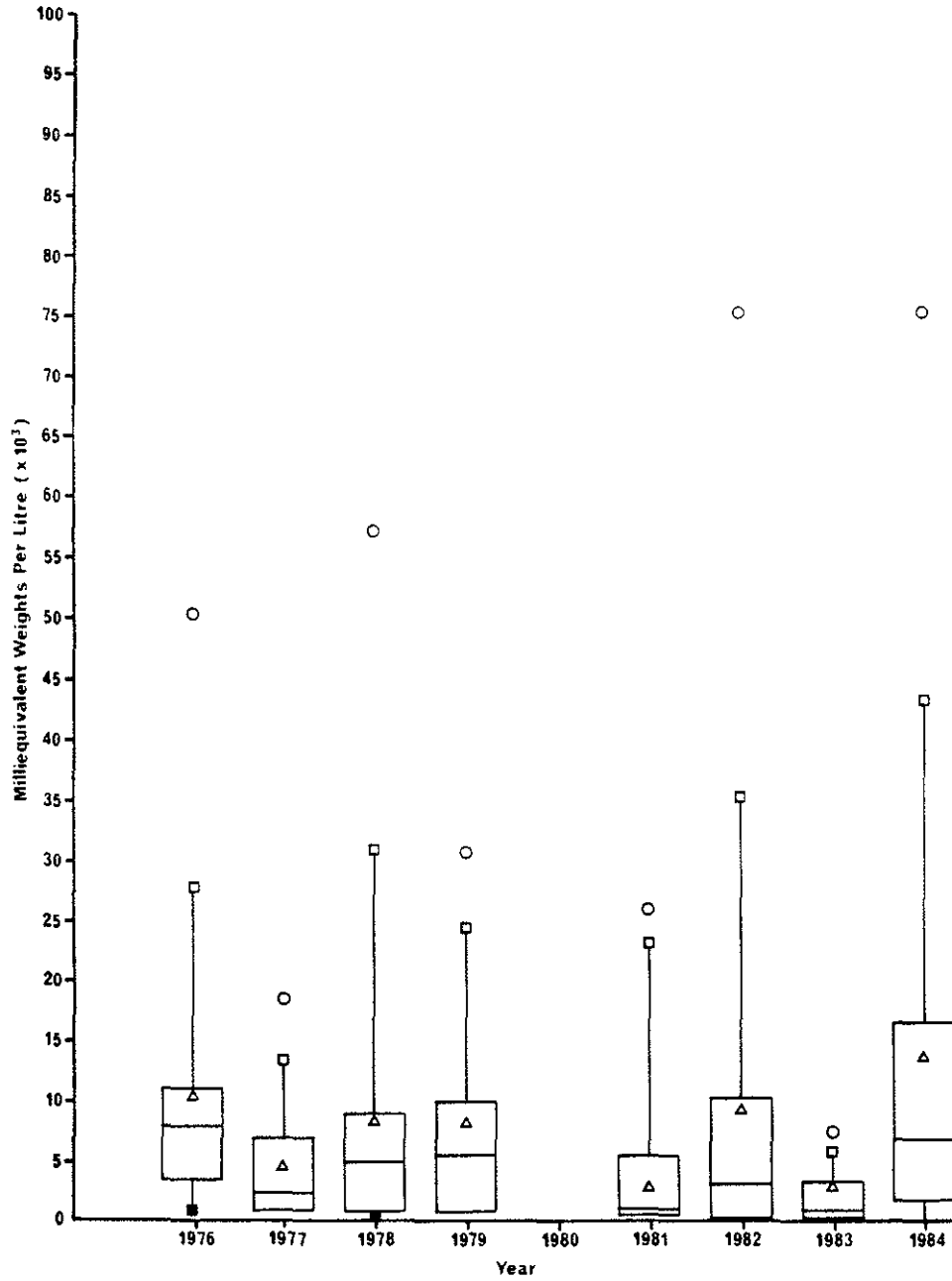

Figure 17. Box plots for the annual distribution of the potassium ion concentration in rain samples in the AOSERP network.

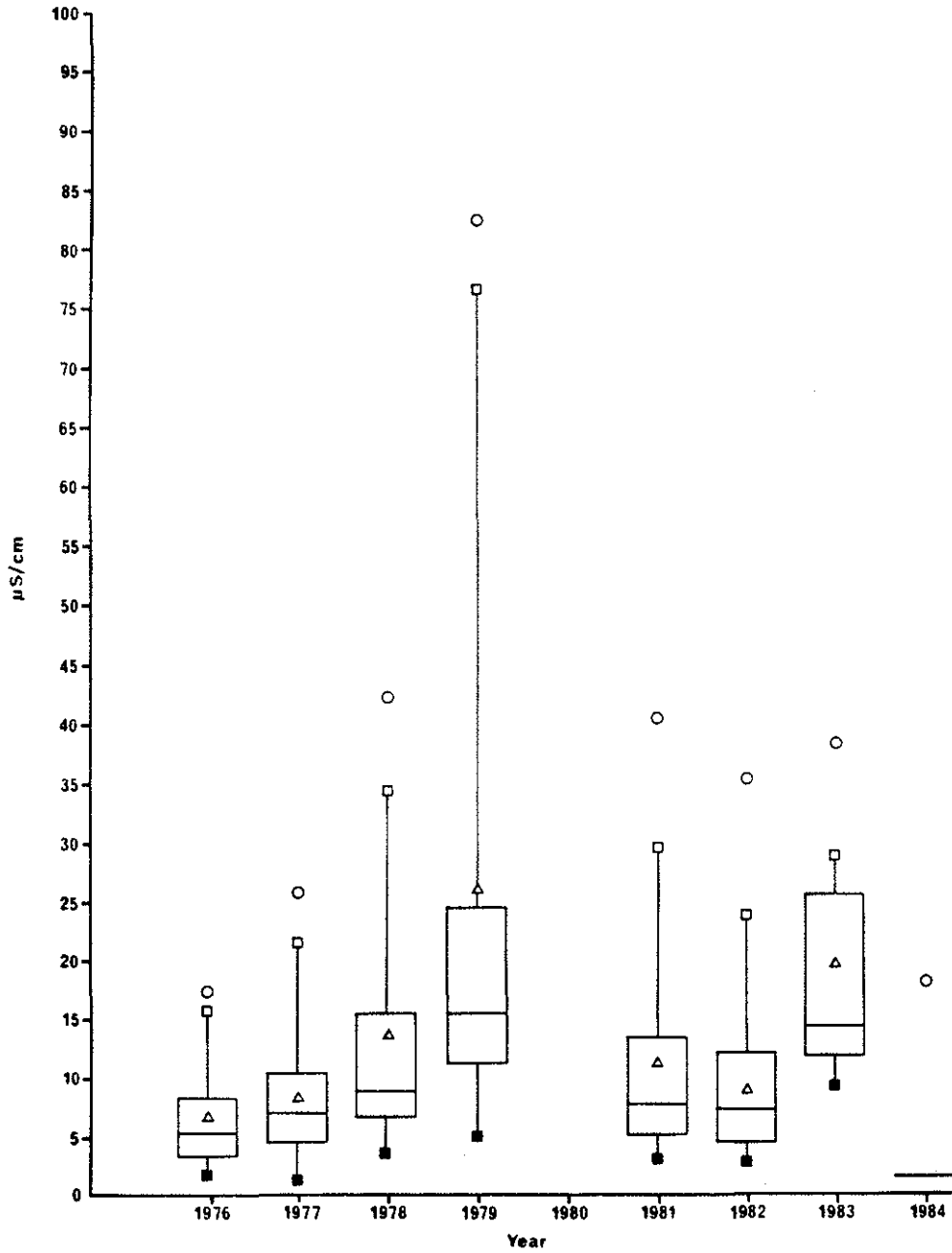

Figure 18. Box plots for the annual distribution of conductance in rain samples in the AOSERP network.

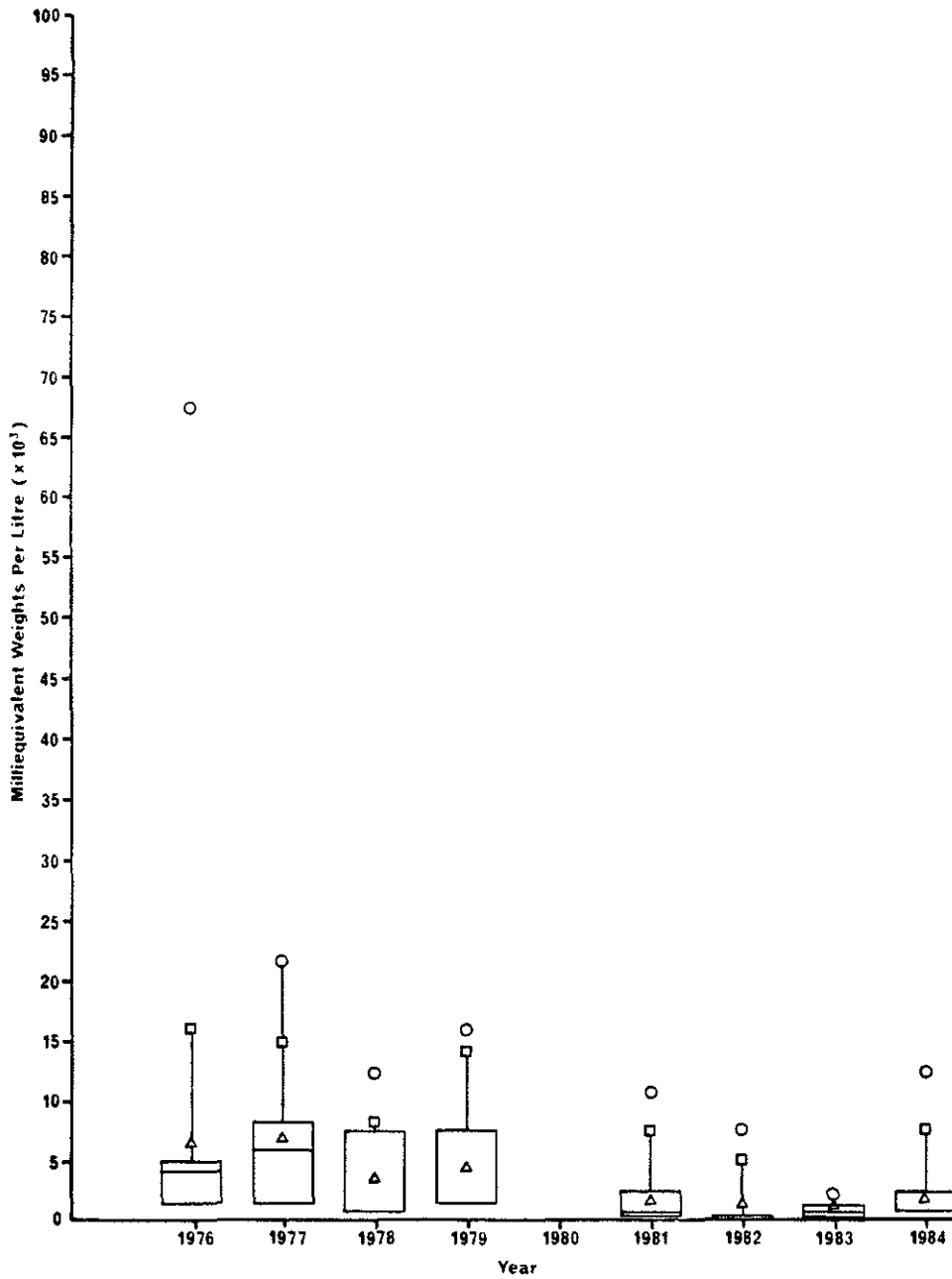

Figure 19. Box plots for the annual distribution of the ammonium ion concentration samples in the AOSERP network.

tions. The box plots for conductivity show that conductivity increased between 1976 and 1979, but decreased in 1982 through 1984. Again, this likely reflects changes in network operational protocols.

The box plots suggest that there may have been increasing levels in pollutants between 1976 and 1979 (due to increasing emissions?), but thereafter levels were varied or declined in some cases (due to reduced emissions or changes in network protocols?). It should be stressed that these hypotheses are neither firmly supported by statistically significant data nor by the certainty that sampling and analytical protocols provided consistently reliable data.

5.2.1.2 Trends in Annual and Monthly Means. Annual means for selected parameters (those indicated in the frequency distributions) at all stations were determined. The trends in the overall annual means (i.e., all stations or a network mean) were indicated in the box plots. However, monthly means were calculated for selected stations (28-Grande Tower, 34-Johnson, 35-Keane Creek, and 95-Sandalta) and parameters ( $\text{SO}_4^{2-}$ ,  $\text{H}^+$ ,  $\text{NH}_4^+$ ,  $\text{Ca}^{2+}$ , and  $\text{Na}^+$ ), and plots of these are given in Figures 20 to 24. Note that the annual mean with error bars indicating standard deviations for four stations (offset each year) are given on each plot. The selection of stations was somewhat arbitrary, but the following aspects were considered:

1. Data variability, and
2. Extreme values for the sulphate concentrations.

Data for the Sandalta station were selected because they were the only available ones in 1983; samples collected in 1983 were for QA/QC purposes. The stations (28, 34) with the highest and second-highest mean sulphate concentrations in 1984 and the station (35) with the lowest sulphate concentrations in 1984 were selected.

The patterns in the annual means for sulphate at the four stations (Figure 20) are similar in that the 1976 through 1979 data were lower than in later years and the variability in the data is greater in later years.



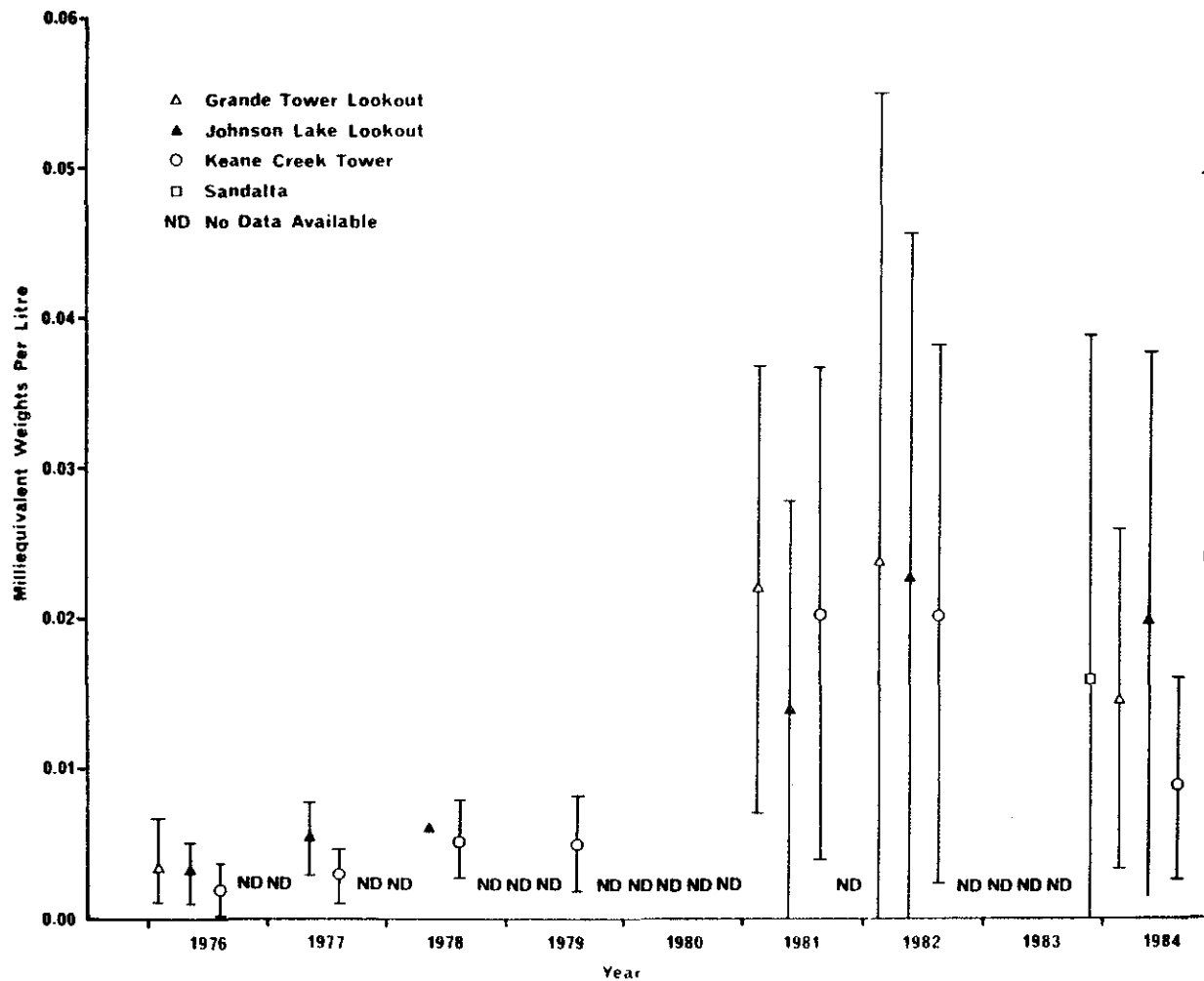

Figure 20. Annual mean sulphate ion concentrations at selected stations in the AOSERP network.

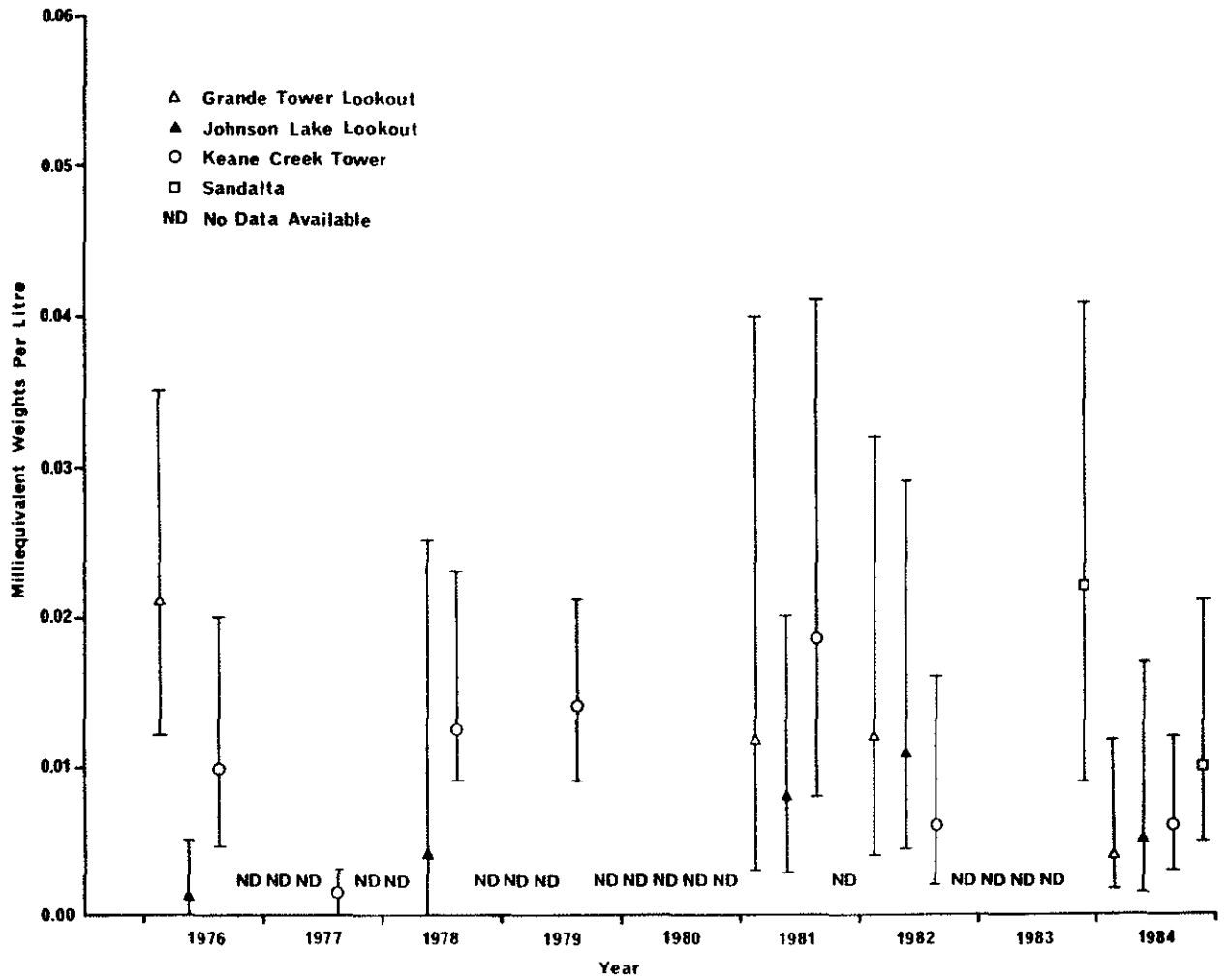

Figure 21. Annual mean hydrogen ion concentrations at selected stations in the AOSERP network.

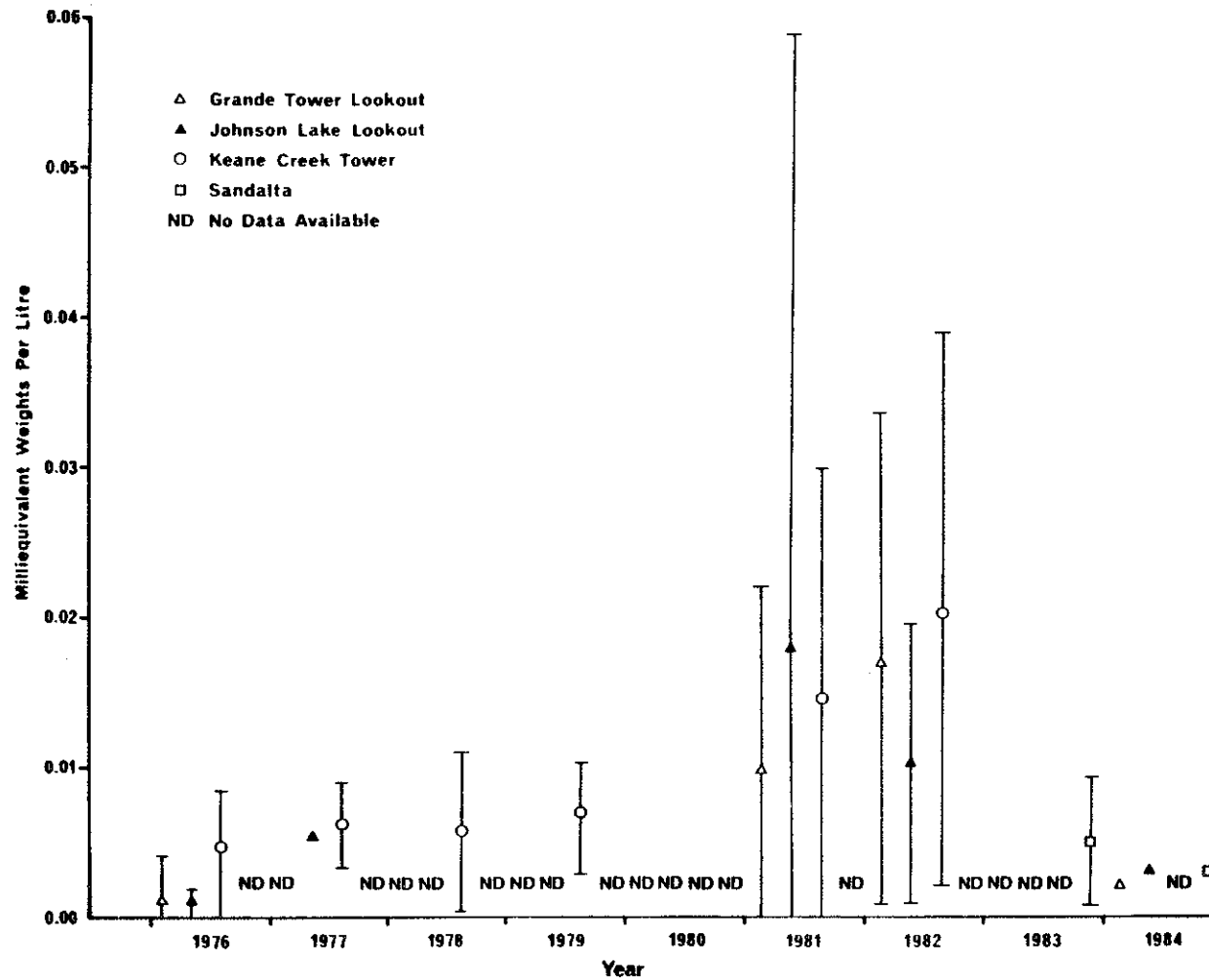

Figure 22. Annual mean ammonium ion concentrations at selected stations in the AOSERP network.

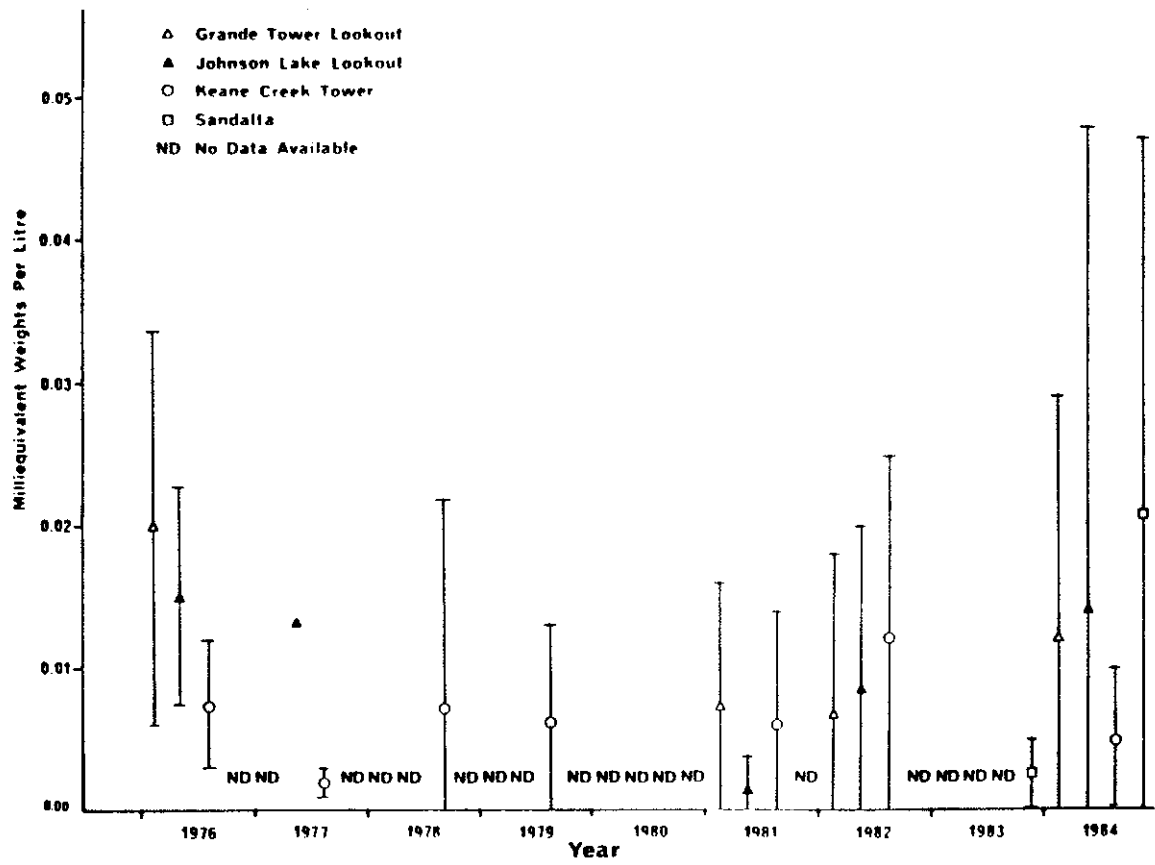

Figure 23. Annual mean calcium ion concentrations at selected stations in the AOSERP network.

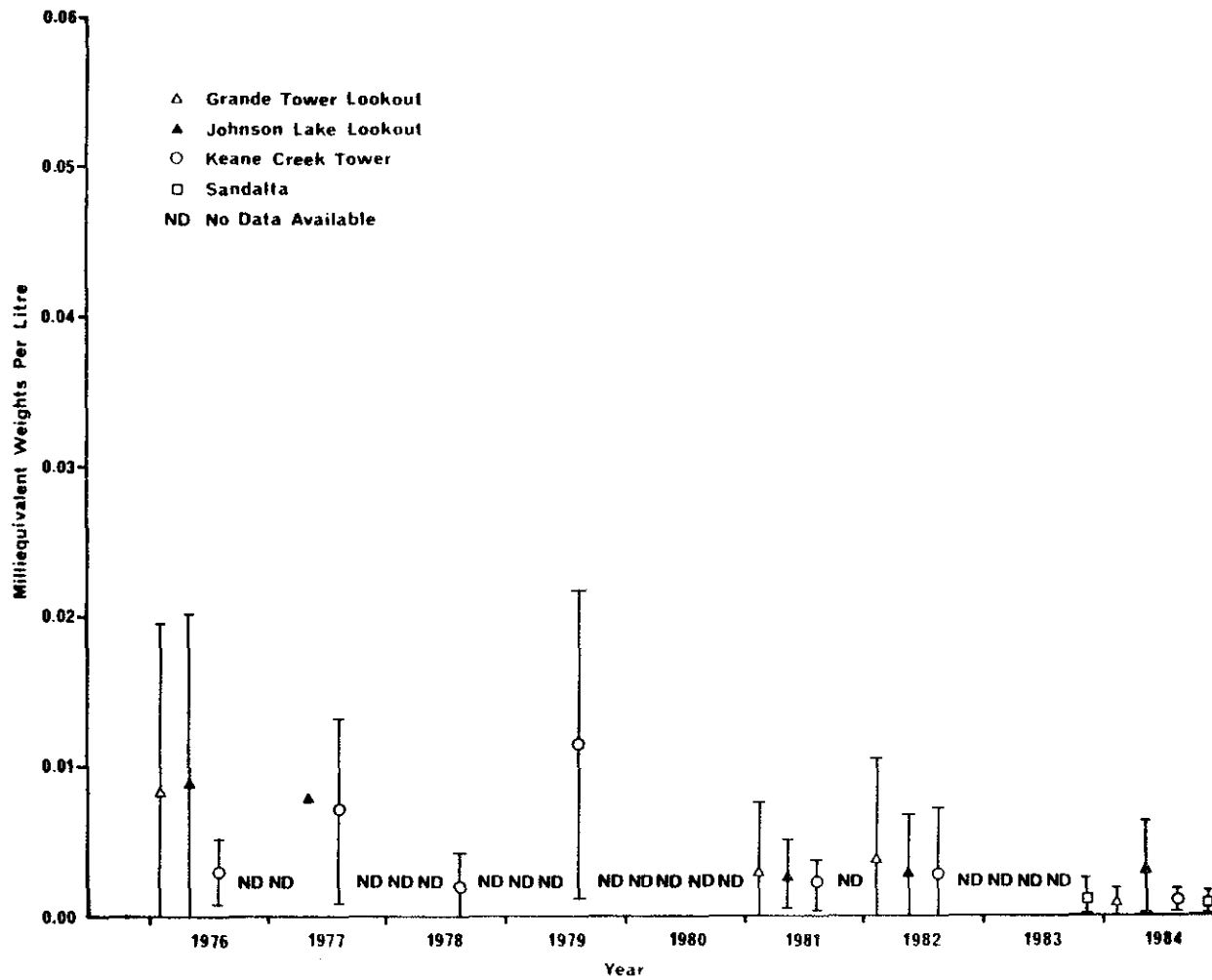

Figure 24. Annual mean sodium ion concentrations at selected stations in the AOSERP network.

The annual mean hydrogen ion concentrations show no consistent pattern, but the  $H^+$  levels at Johnson were generally, though not consistently, lower than at the other stations. The pattern of annual mean  $NH_4^+$  concentrations is somewhat like that for sulphate: lower levels in 1976 to 1979 and higher, more variable levels in 1981 and 1982. However, the 1984 levels were lower than in 1981. Calcium levels were lowest in 1981, with higher levels in earlier and in later years. The later (1984) data were generally more variable. Sodium levels were generally relatively lower (in terms of milliequivalents/litre) and less variable than other parameters.

### 5.2.2 Spatial Patterns

Attempts were made to prepare annual contour plots for selected parameters. One such plot for the mean sulphate concentration for 1984 is shown in Figure 25. Because of the inherent large scatter in the data (the relative standard deviations were of the order of 100%), the areas bounded by the standard deviations associated with each contour line would overlap at least two adjacent contour lines. In view of this, Figure 25 may not be interpreted with much confidence. Since the relative standard deviations for the annual means for other parameters were similarly large, isopleths based on monthly means were examined to see if spatial patterns could be established for this shorter averaging period. Monthly means also showed high variability. Figure 26 illustrates the isopleth for sulphate in June 1984. Notwithstanding the caveats above, and noting also that the annual period refers to the May to September period only, the annual isopleths provide relatively better indications of spatial patterns than corresponding monthly isopleths. Figures 27 to 30 show such isopleths for pH and  $NH_4^+$  in 1982 and for  $NO_3^-$  and  $Ca^{2+}$  in 1984.

The isopleths show few consistent patterns and, in view of the variability in the data as discussed above, they should not be interpreted further.

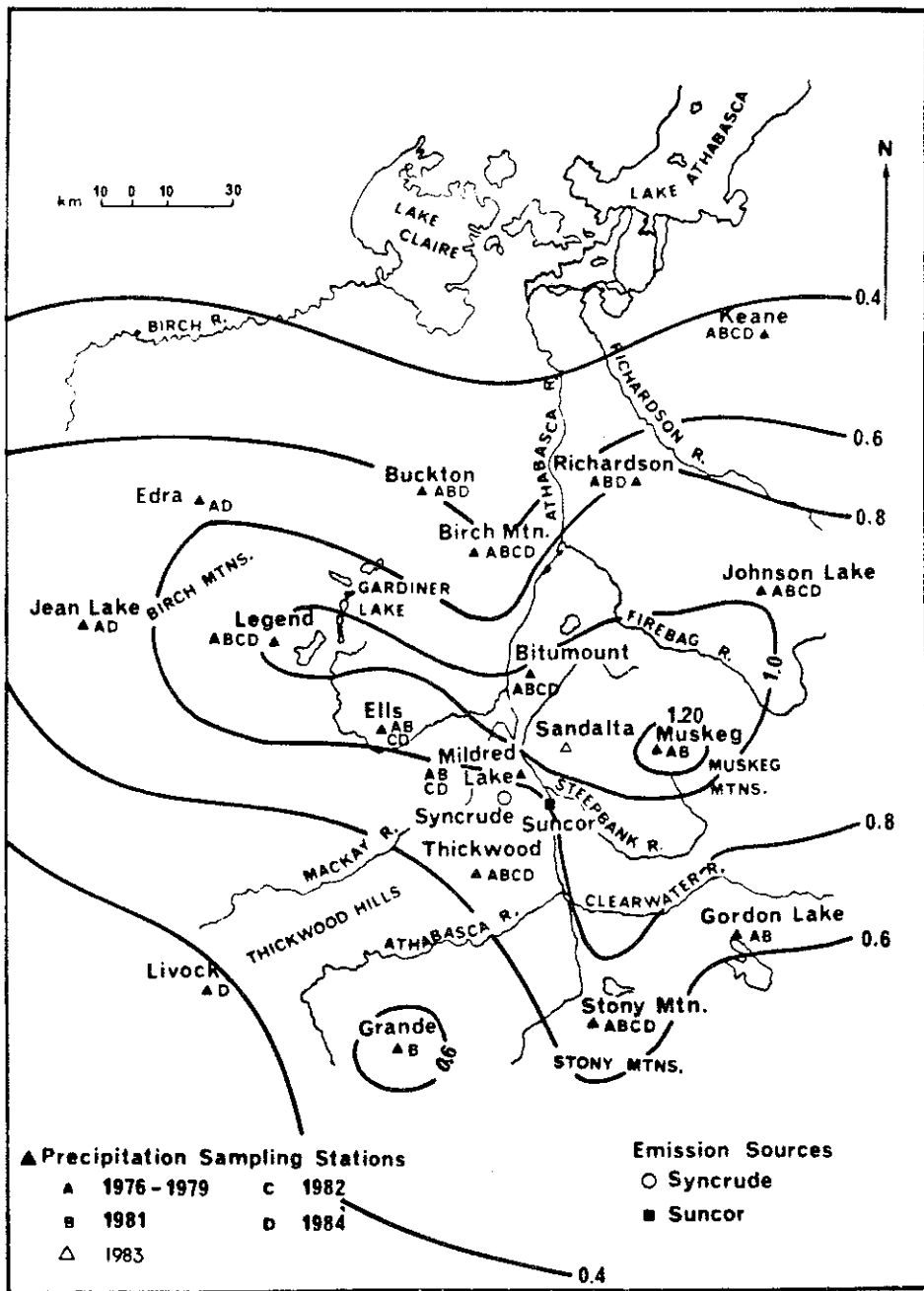

Figure 25. Annual isopleth (1984) for the mean sulphate ion concentrations in rain samples in the AOSERP network.

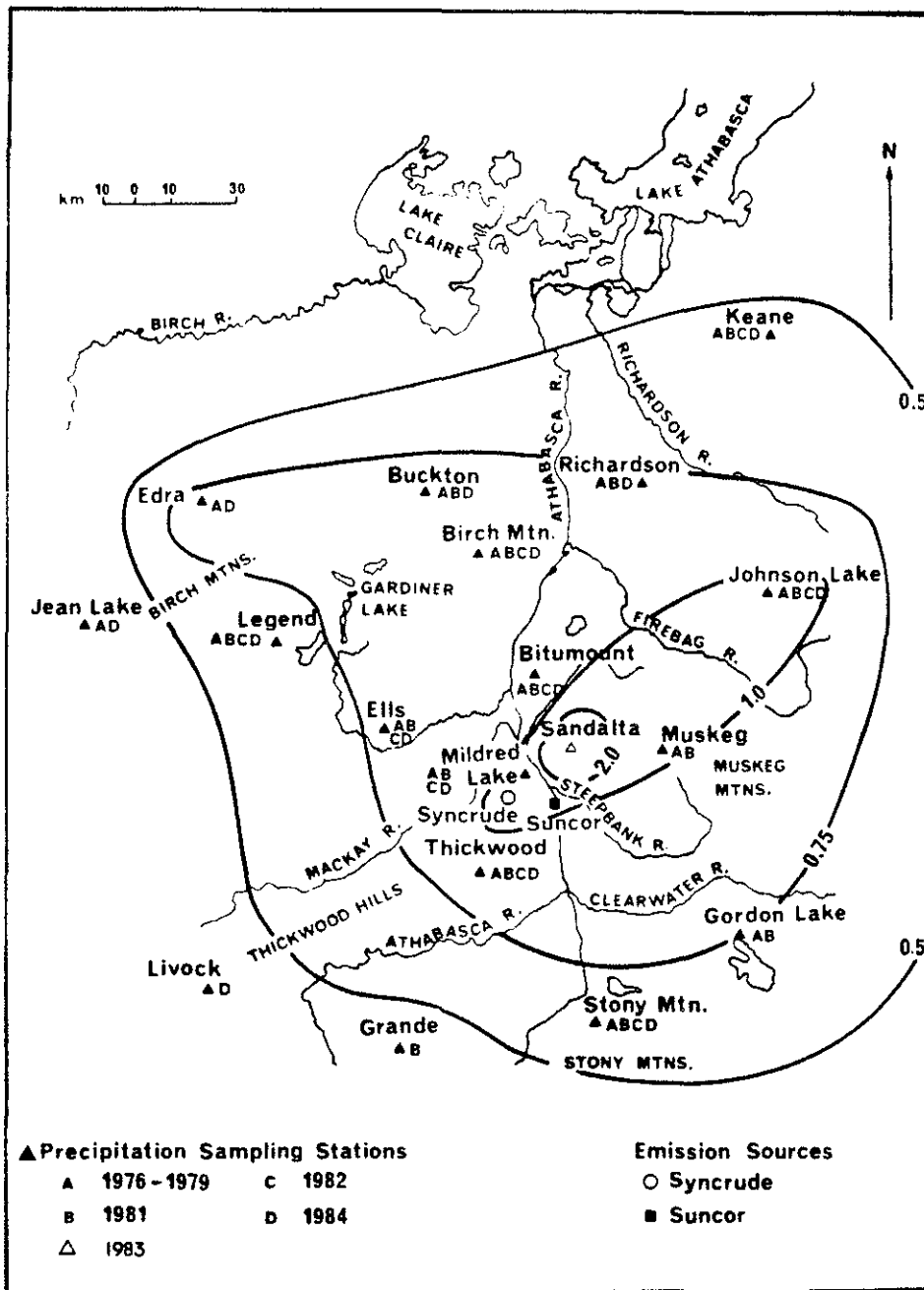

Figure 26. Monthly isopleth (June 1984) for the mean sulphate ion concentrations in rain samples in the AOSERP network.



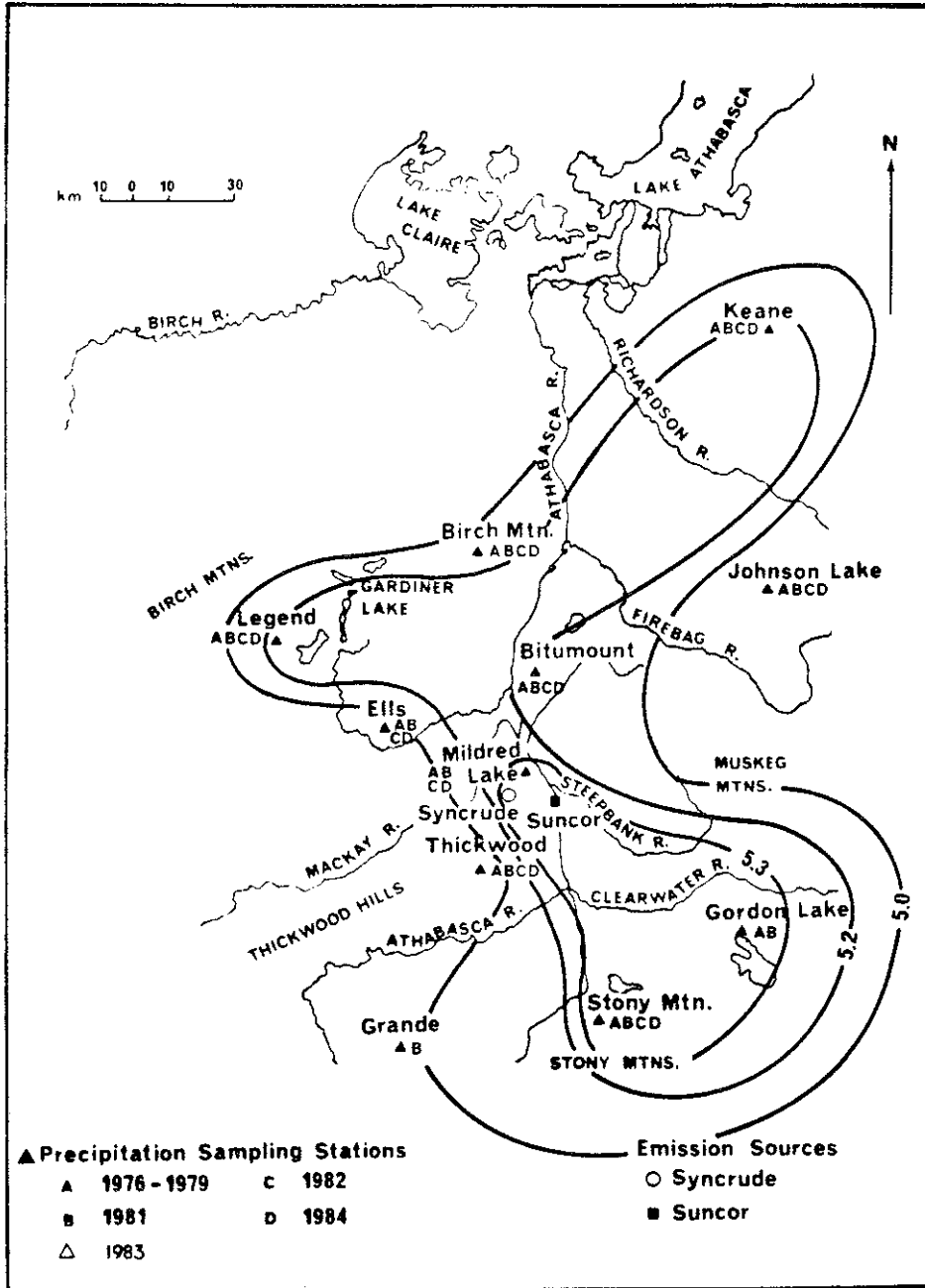

Figure 27. Annual isopleth (1980) for pH of rain samples in the AOSERP network.

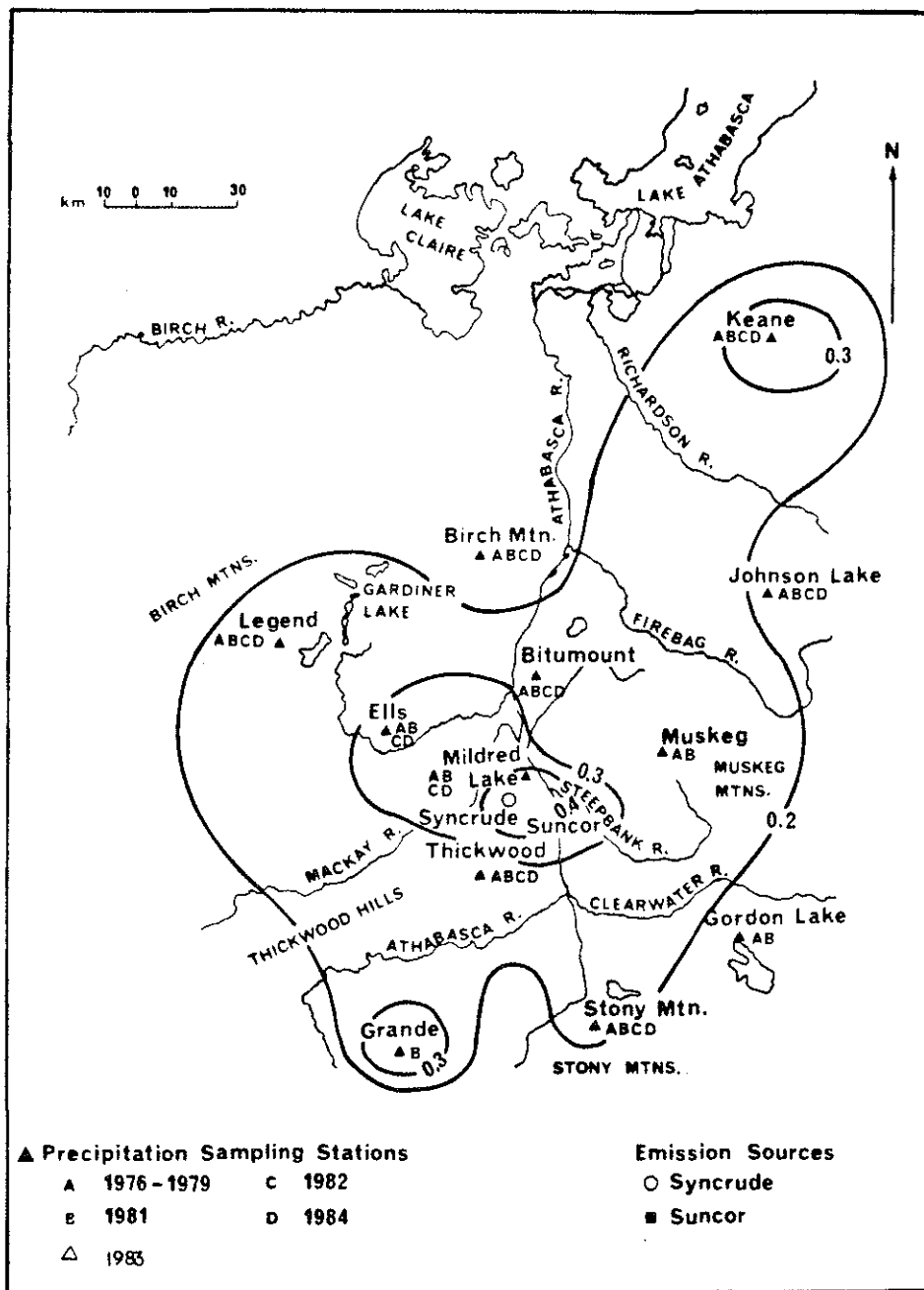

Figure 28. Annual isopleth (1982) for ammonium ion concentrations in rain samples in the AOSERP network.

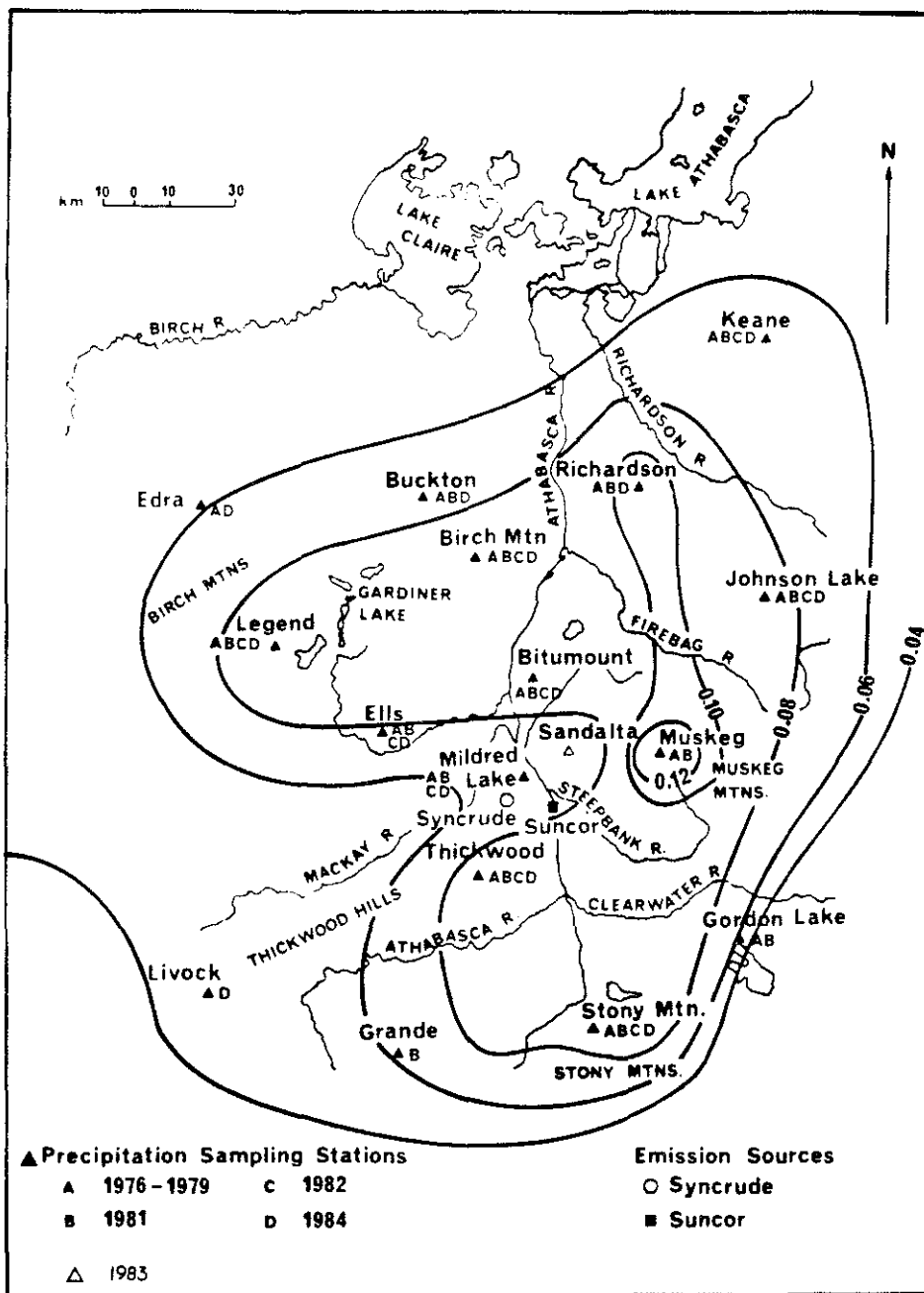

Figure 29. Annual isopleth (1984) for nitrate ion concentrations in rain samples in the AOSERP network.

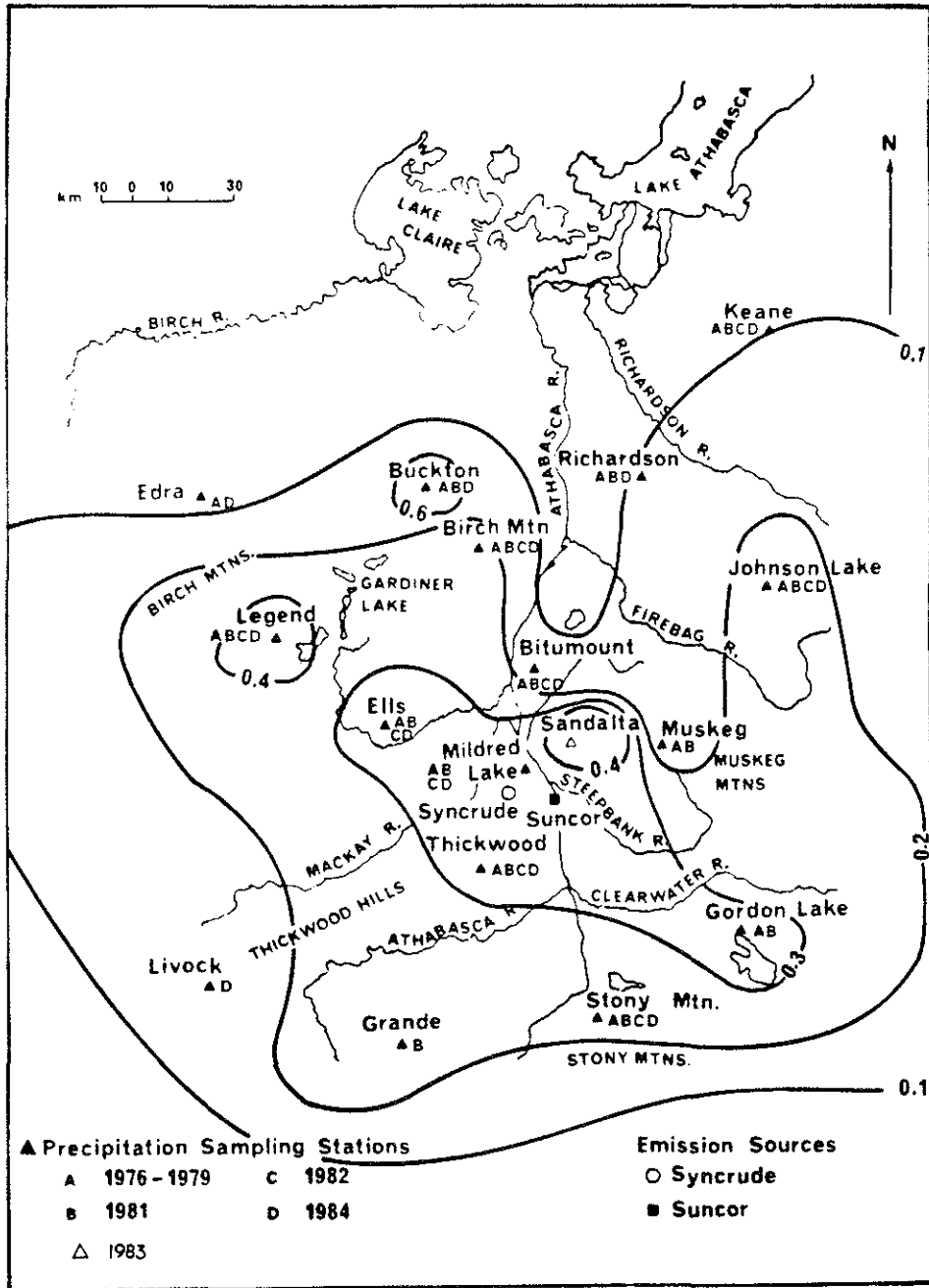

Figure 30. Annual isopleth (1984) for calcium ion concentrations in rain samples in the AOSERP network.

### 5.3 STATISTICS ON SNOW DATA

The analysis of snow data for temporal and spatial trends involved the use of data spanning some nine years, during which there were varying numbers of stations and sampling and analytical protocols. In view of the heterogeneity of the data set, some conclusions (see below) need to be viewed with caution. It should be noted that the analysis conducted to determine the QA/QC aspects of sampling and analytical procedures have given some indication of the extent to which data were comparable and/or reliable. A subset of the data representing selected stations for those years in which there were extensive snow surveys (1978, 1981, 1983, 1984) were used to determine the network-wide temporal and spatial trends and inter-parameter relationships. The subset was selected on the following bases:

1. It was arbitrarily assumed that the 1984 data were most reliable. This was found to be reasonable based on the conclusions already presented (see Chapter 4).
2. Only those stations operated in 1984 were included in the subset.
3. Only those parameters measured in all years (pH,  $\text{NO}_3^-$ ,  $\text{SO}_4^{2-}$ ,  $\text{Cl}^-$ ,  $\text{Na}^+$ ,  $\text{K}^+$ ,  $\text{Ca}^{2+}$ ,  $\text{Mg}^{2+}$ , alkalinity, Al, Fe, and V) were included. In the case of the three metals, the analyses specified as "dissolved" were selected.

As was the case for the rain data, frequency distributions and annual (but not monthly) means for selected parameters were calculated, and box plots indicating network-wide trends were prepared. In addition, annual means at selected stations are presented, but it should be noted that the number of samples at each station for each year is small (only one or two sampling periods each year). The results of these analyses are presented and discussed in the following sections.

#### 5.3.1 Temporal Trends

Box plots illustrating the annual frequency distributions for the major anions and cations on a network-wide basis are shown in

Figures 31 to 41. In view of the fact that sulphate and pH were the only parameters measured in 1976 that were common to subsequent years, the box plots for sulphate and pH include 1976 data, but the differences in sampling and analytical methods should be borne in mind. These plots indicate the temporal trends on a network-wide basis. It should be remembered that relatively large amounts of the 1981 data did not meet the screening criteria and the plots reflect few data for 1981.

The box plot for  $H^+$  (Figure 31) shows that the lowest pH (highest  $H^+$ ) occurred in 1981. The distribution of  $SO_4^{2-}$  levels (Figure 32) was most varied in 1984 but, as is the case for  $H^+$ , there are no apparent trends with time.  $NH_4^+$  levels (Figure 33) were low relative to  $SO_4^{2-}$  or  $H^+$  (note units of equivalent weights/litre), and the distributions were similar from year to year for 1983, a year that showed a wider range of values. The pattern in the  $NO_3^-$  distributions (Figure 34) was similar to that for  $NH_4^+$ , with more variable and also higher levels in 1983 than in other years.

The distributions for sodium (Figure 35) in 1978, 1983, and 1984 were similar (low and narrow), but the 1981 levels were higher and more varied. Potassium levels (Figure 36) were relatively low, but the 1983 data were more variable and levels were higher. The calcium levels (Figure 37) were highest (in terms of equivalent weights/litre) and were most variable and high in 1984. Magnesium data (Figure 38) showed little change from year to year, as did chloride (Figure 39), which showed very low levels. The alkalinity levels were higher in 1984 (and more variable) than in 1978 or 1981 (Figure 40). The conductance values showed little pattern (Figure 41), i.e., no significant changes in the distribution from year to year.

### 5.3.2 Spatial Patterns

Isopleths showing the mean concentrations of sulphate at various stations in each of the years 1976, 1978, and 1981 are shown in Figures 42 to 44. Note that only those stations operated in 1984 are included in each figure and that in view of the very high degree

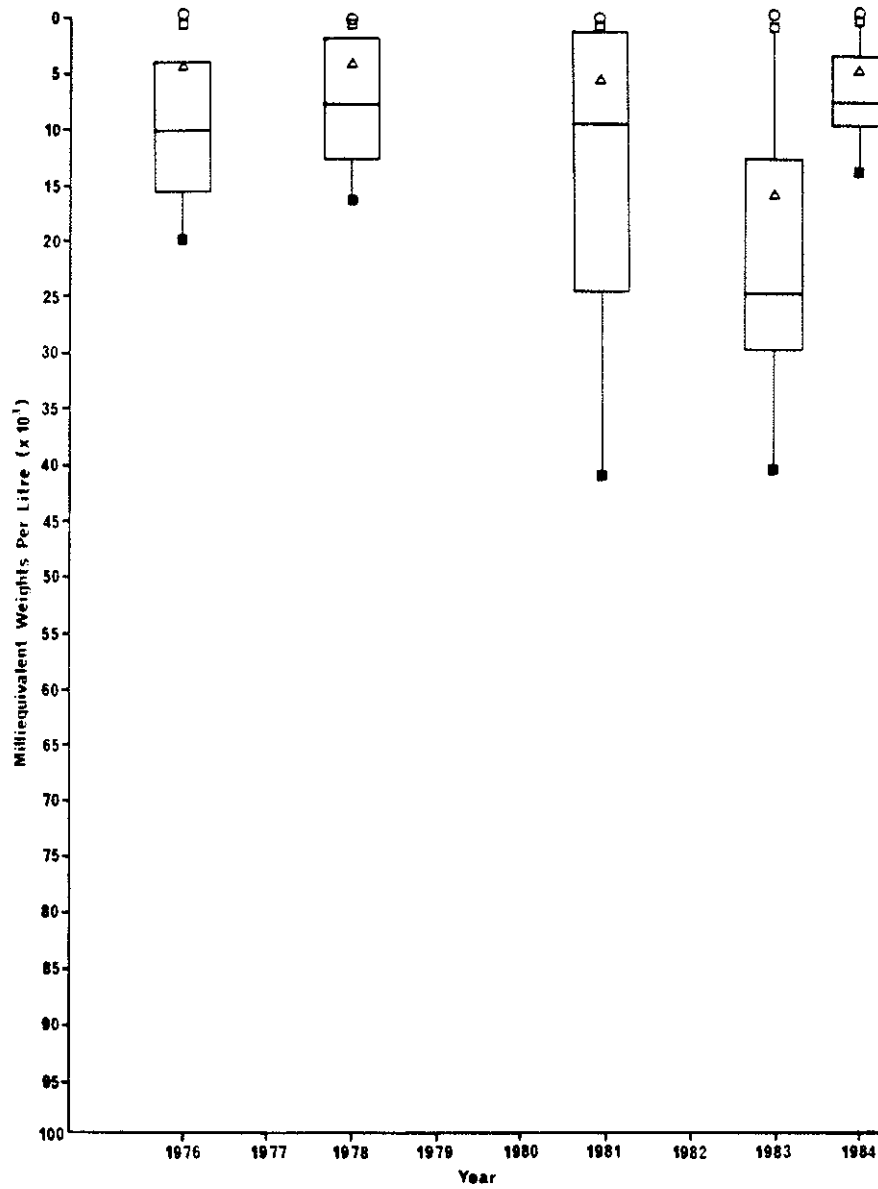

Figure 31. Box plots for the annual distribution of hydrogen ion concentrations in snow samples in the AOSERP network.

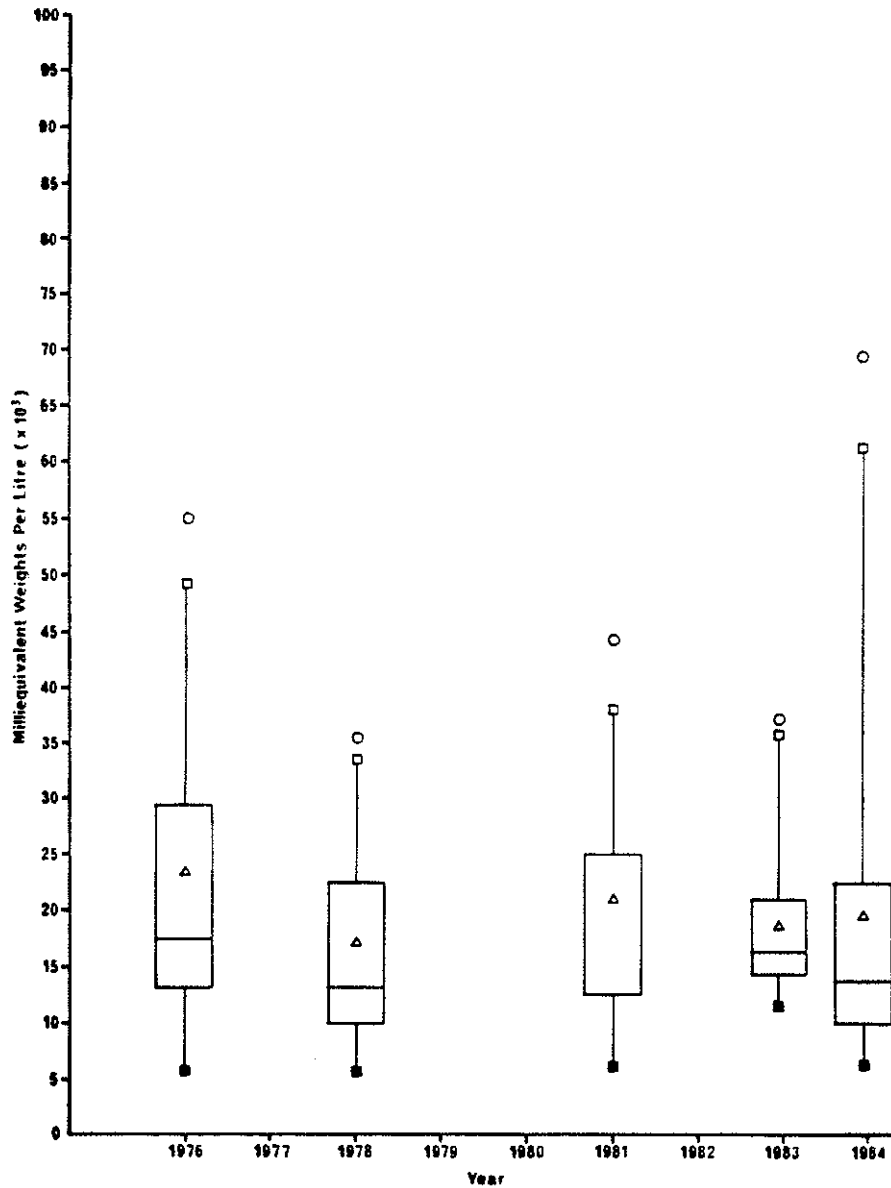

Figure 32. Box plots for the annual distribution of sulphate ion concentrations in snow samples in the AOSERP network.



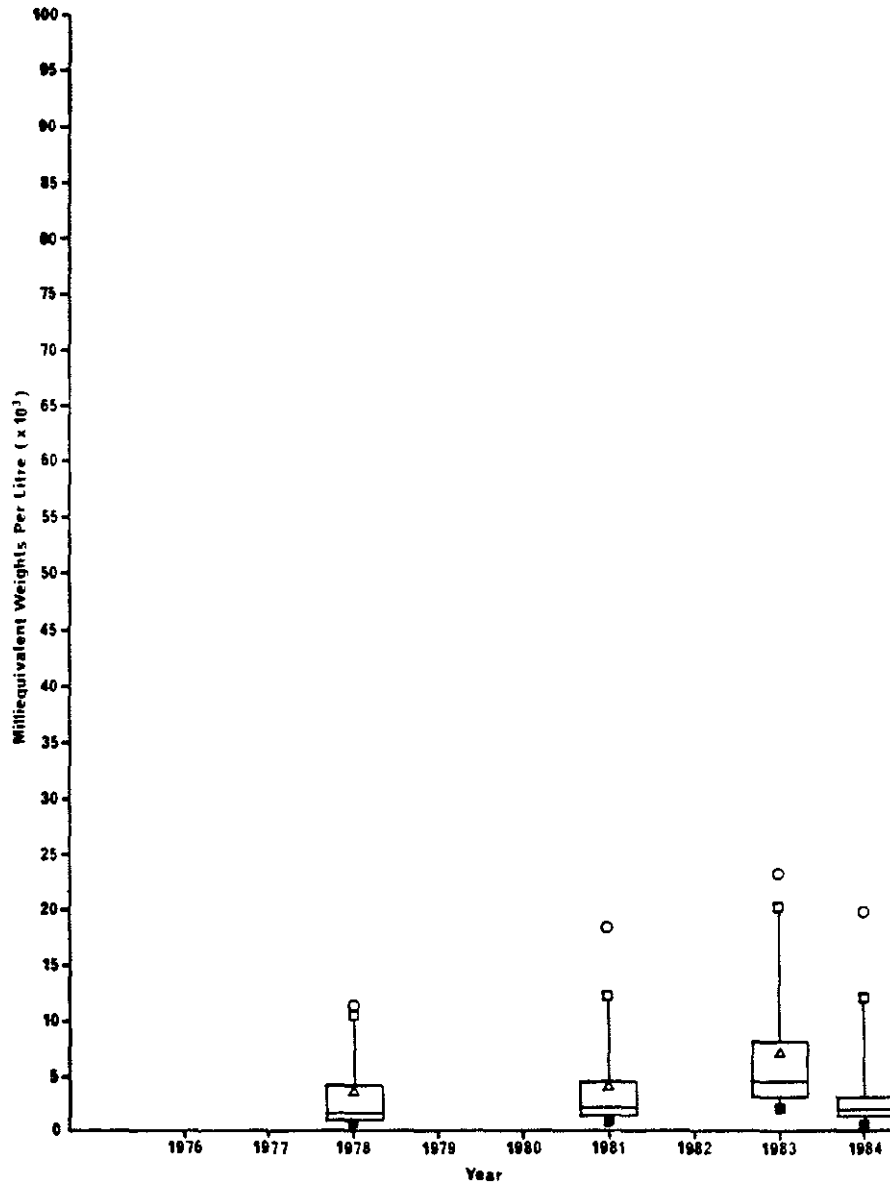

Figure 33. Box plots for the annual distribution of ammonium ion concentrations in snow samples in the AOSERP network.

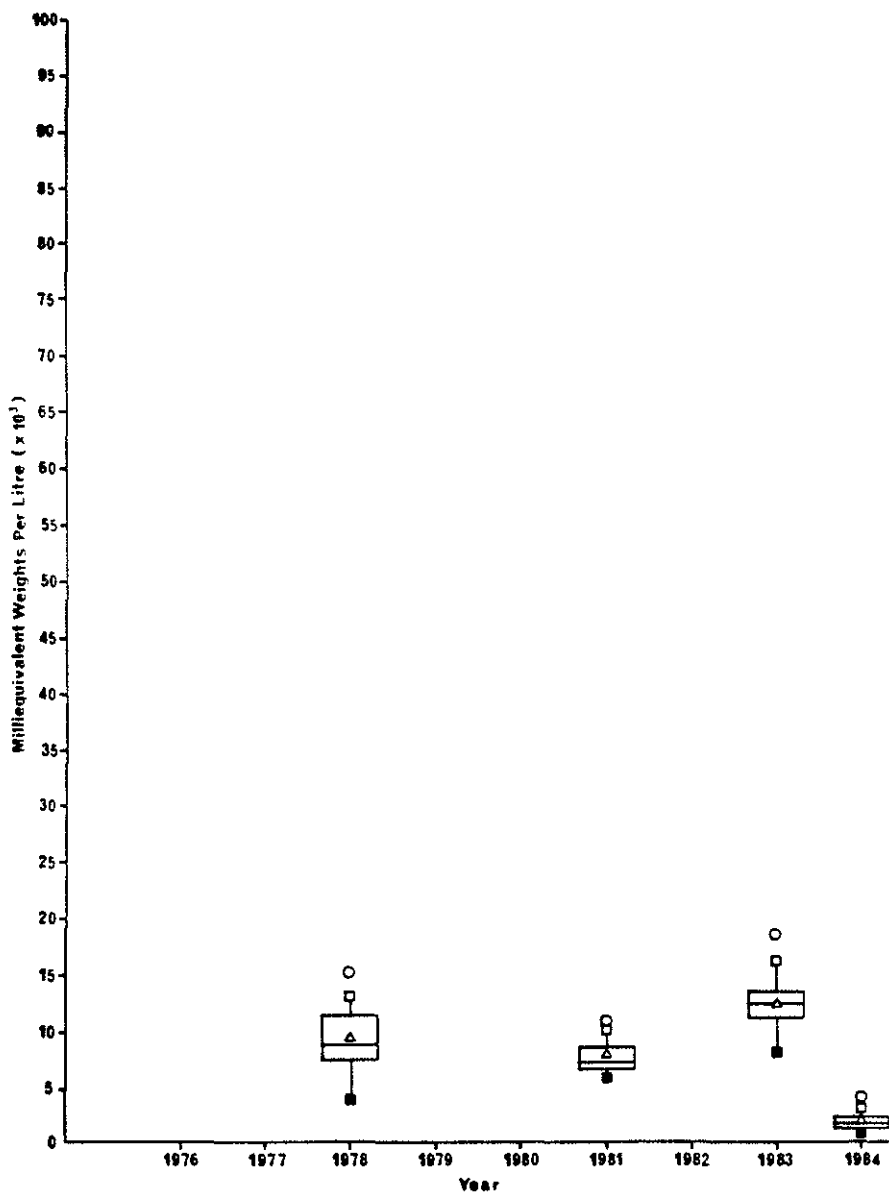

Figure 34. Box plots for the annual distribution of nitrate ion concentrations in snow samples in the AOSERP network.

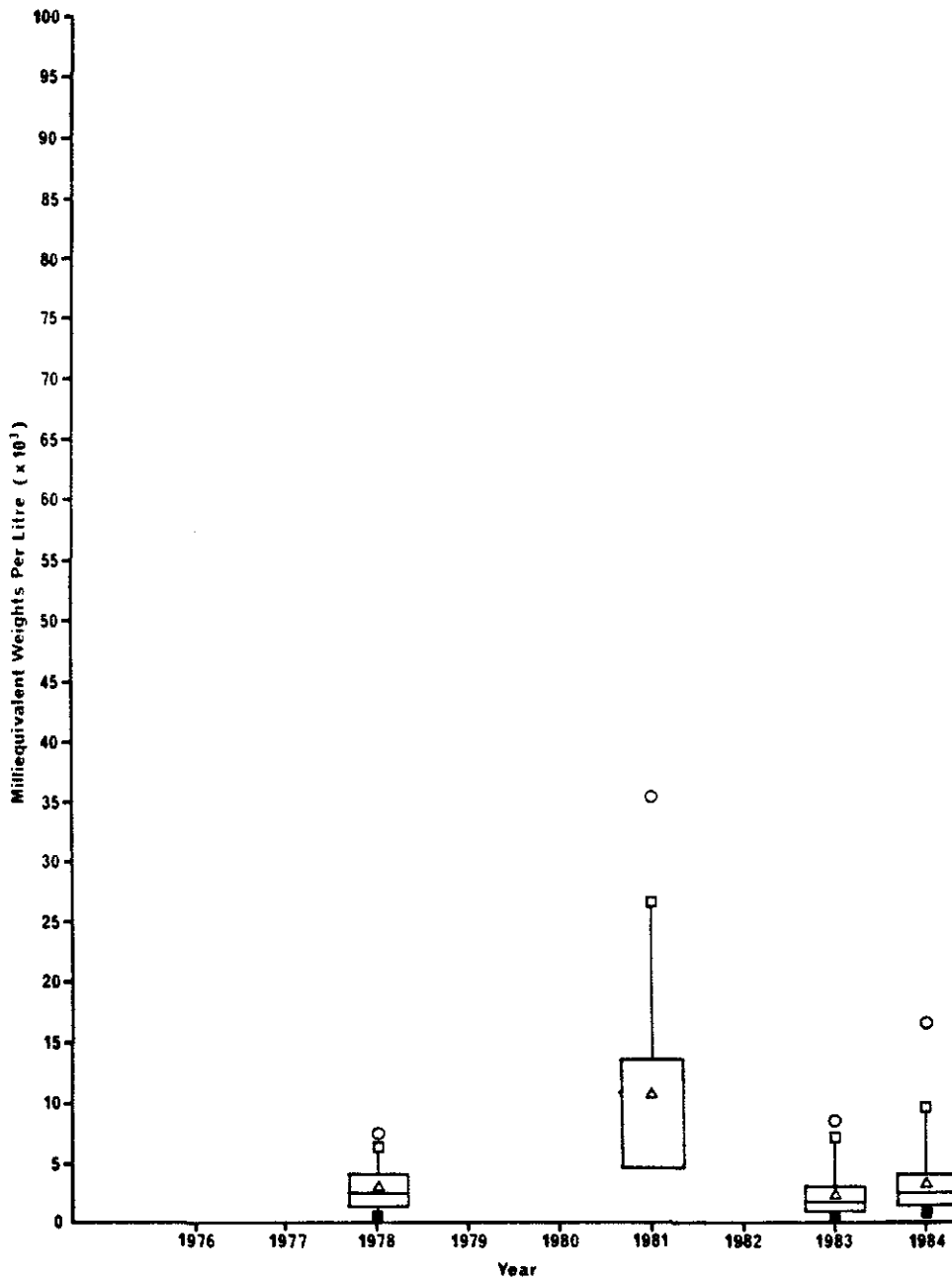

Figure 35. Box plots for the annual distribution of Na<sup>+</sup> in snow samples in the AOSERP network.

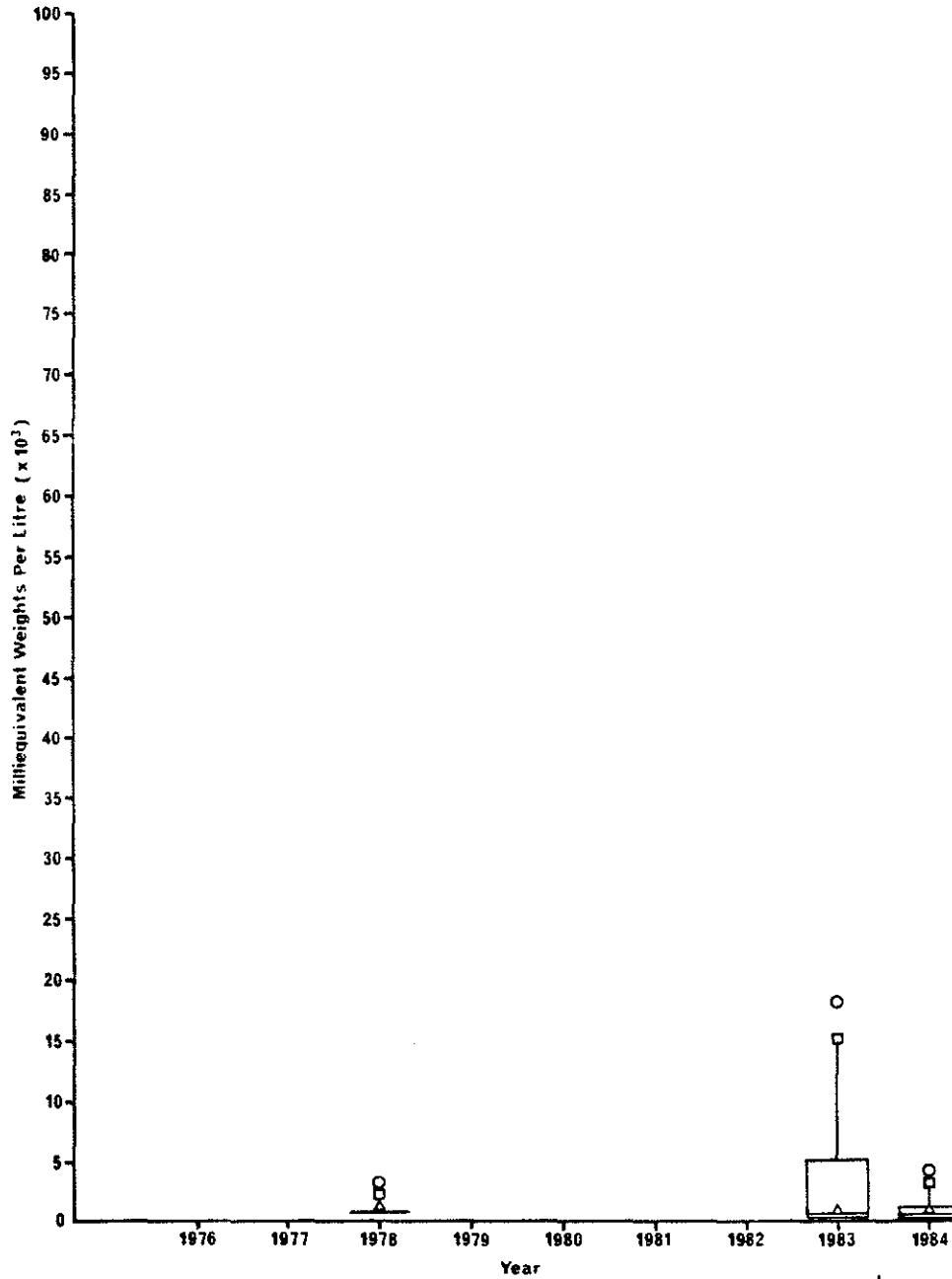

Figure 36. Box plots for the annual distribution of  $K^+$  in snow samples in the AOSERP network.

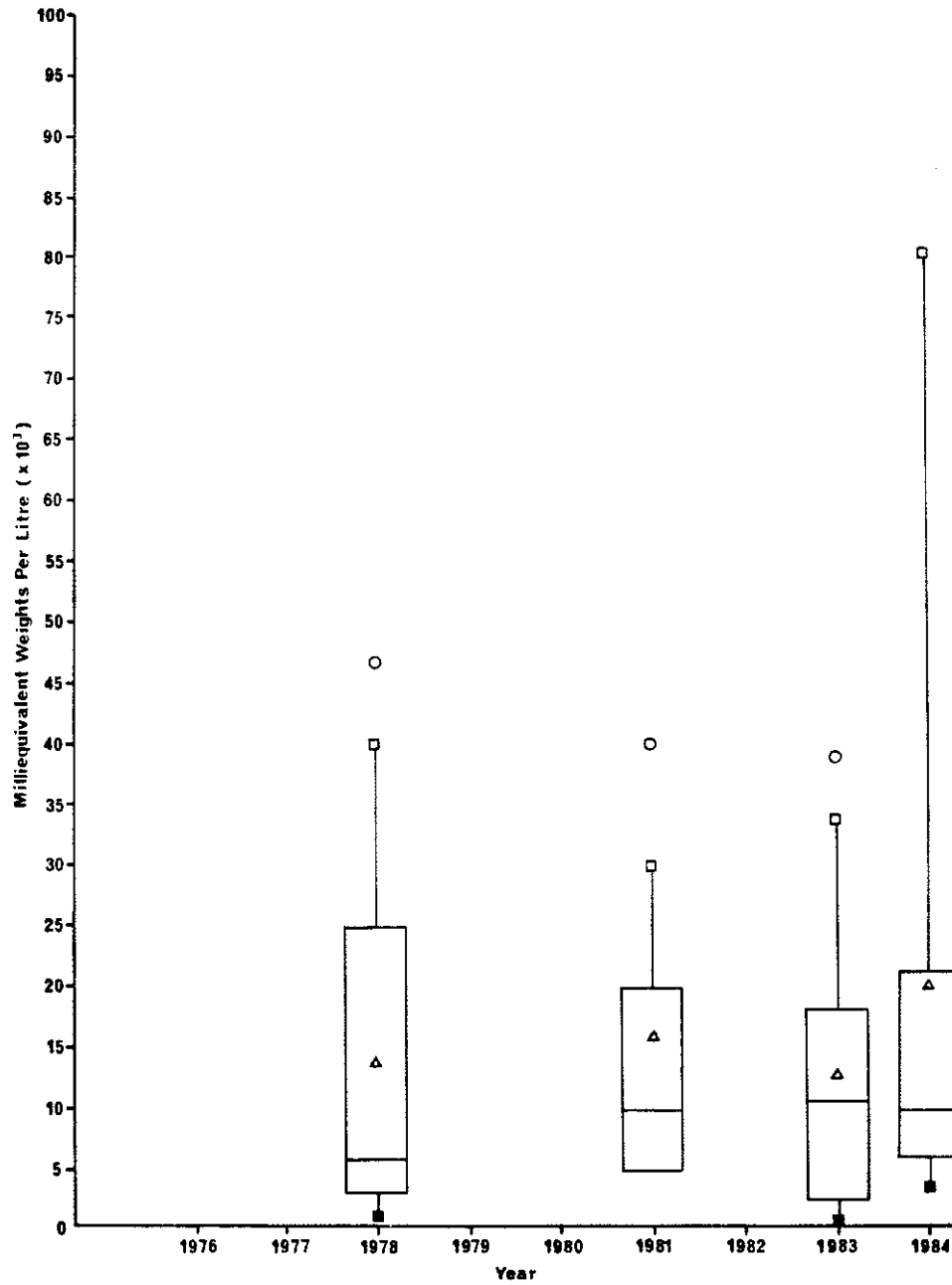

Figure 37. Box plots for the annual distribution of  $\text{Ca}^{2+}$  in snow samples in the AOSERP network.

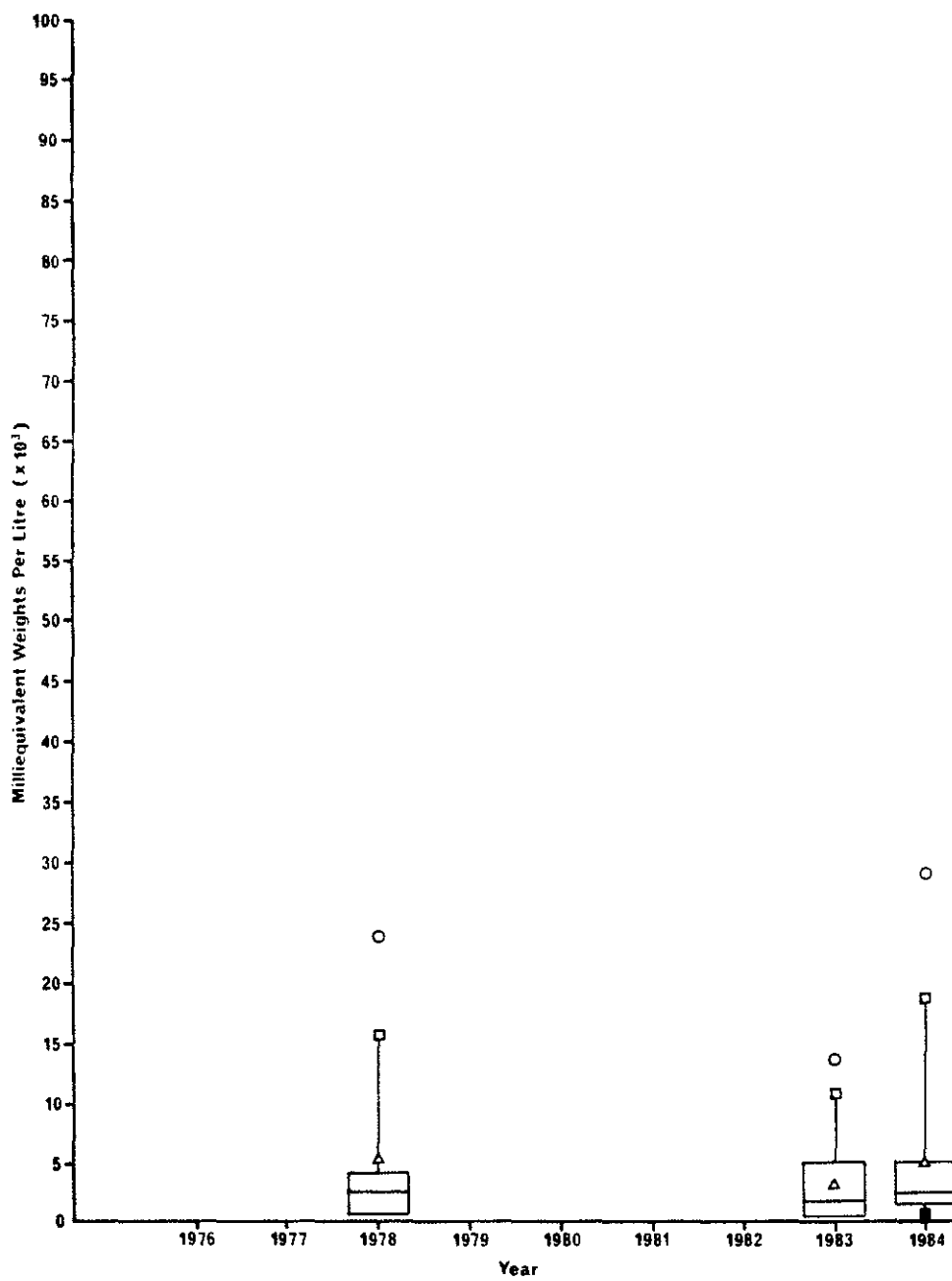

Figure 38. Box plots for the annual distribution of Mg<sup>2+</sup> in snow samples in the AOSERP network.

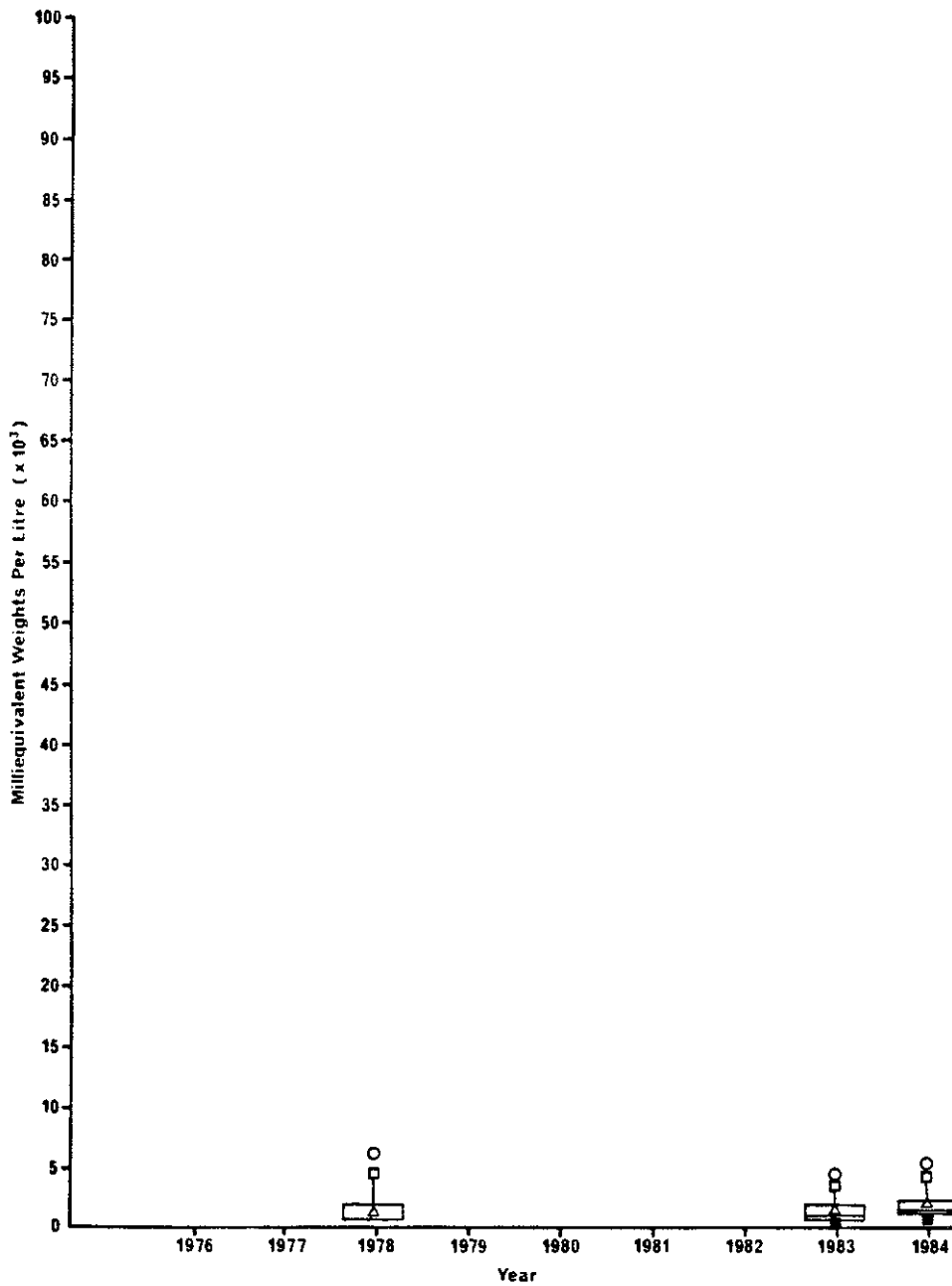

Figure 39. Box plots for the annual distribution of Cl<sup>-</sup> in snow samples in the AOSERP network.

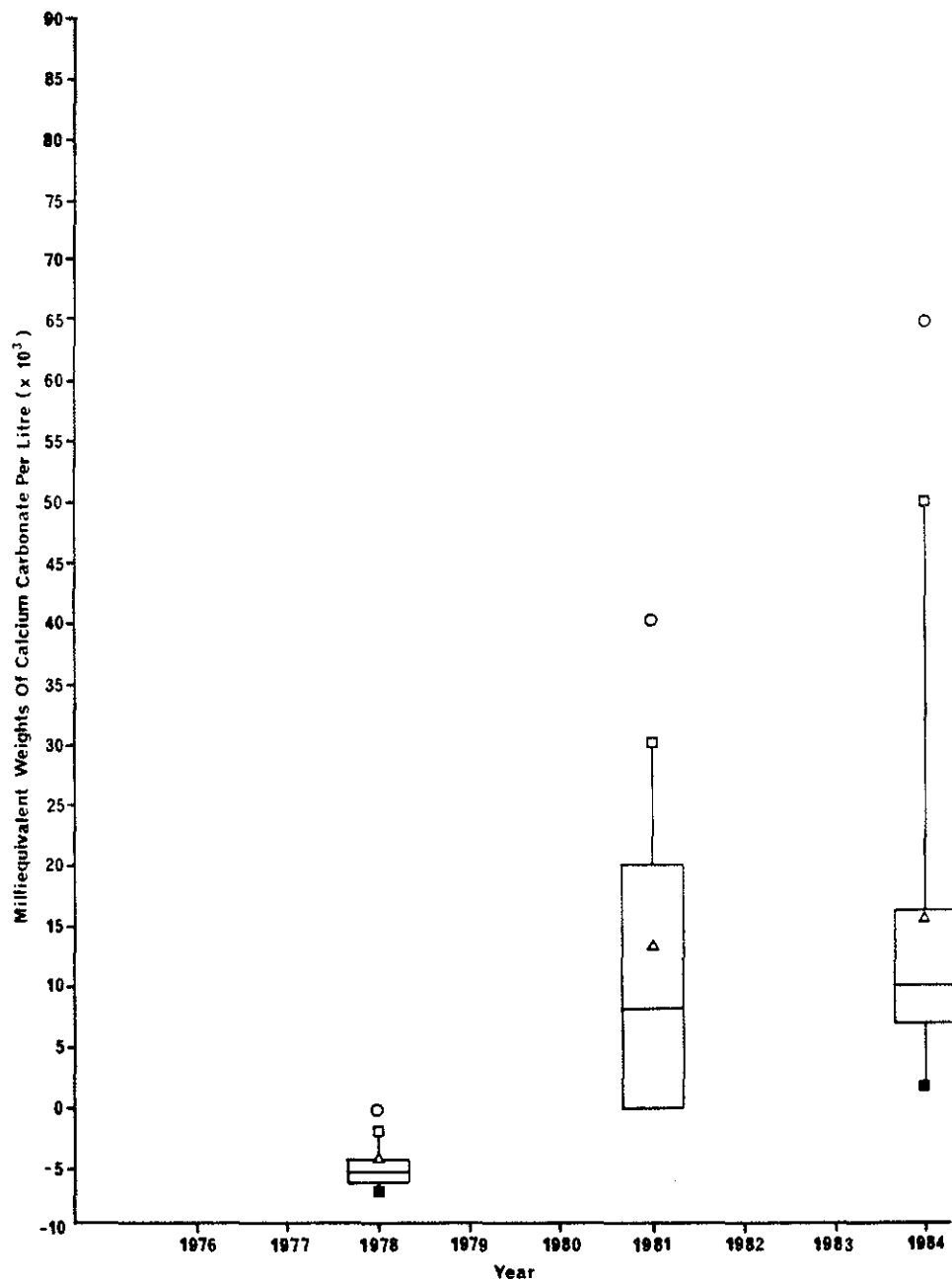

Figure 40. Box plots for the annual distribution of alkalinity in snow samples in the AOSERP network.



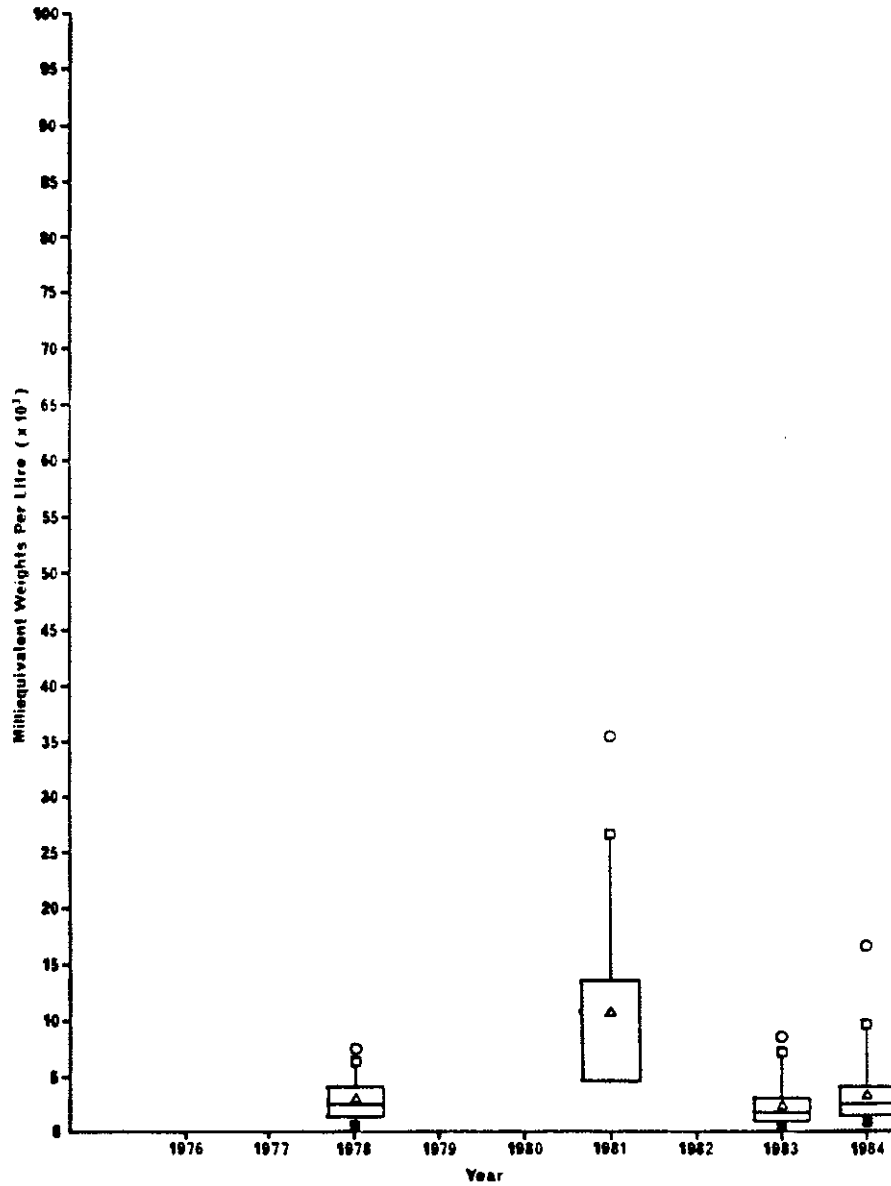

Figure 41. Box plots for the annual distribution of conductance in snow samples in the AOSERP network.

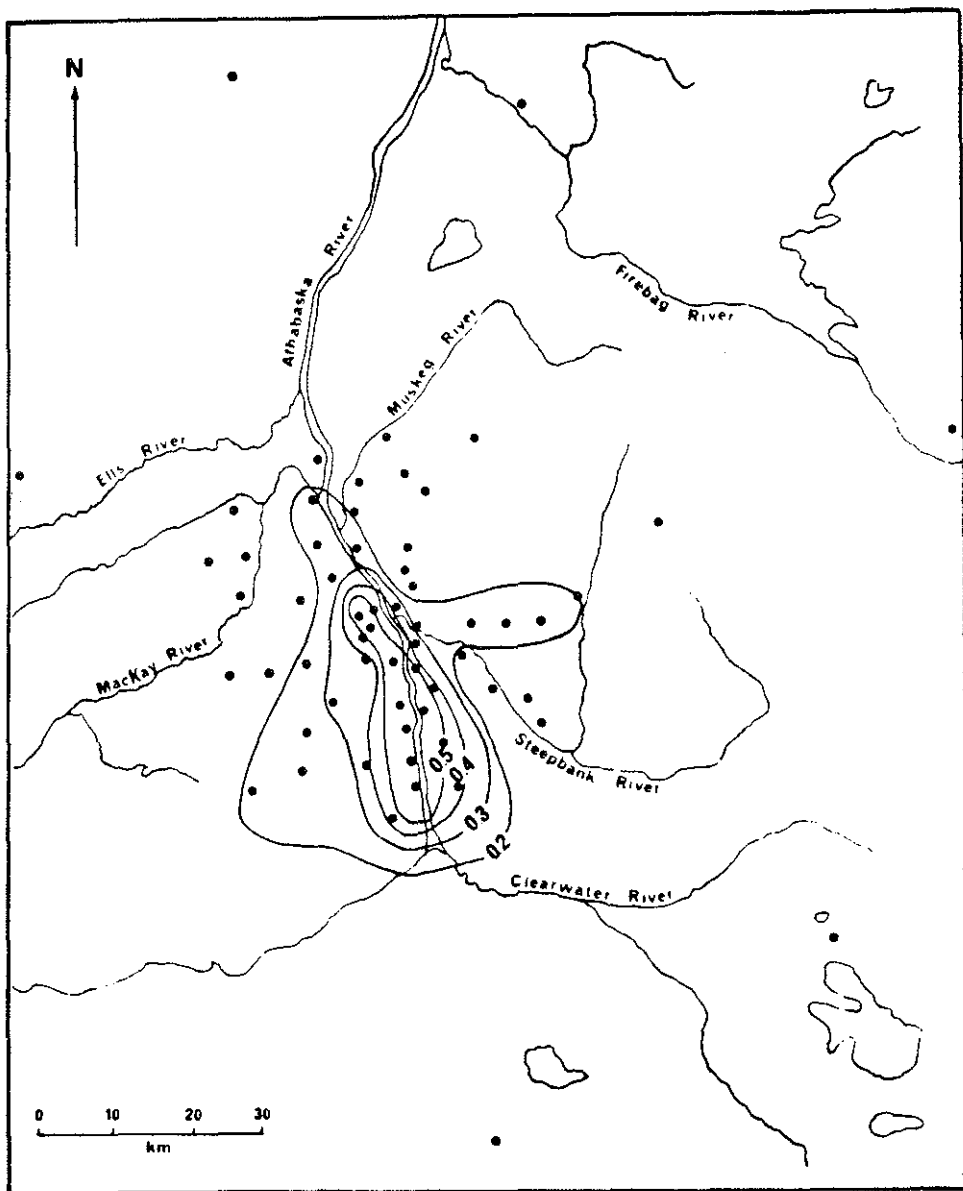

Figure 42. Annual isopleth (1976) for sulphate ion concentrations in snow samples in the AOSERP network.

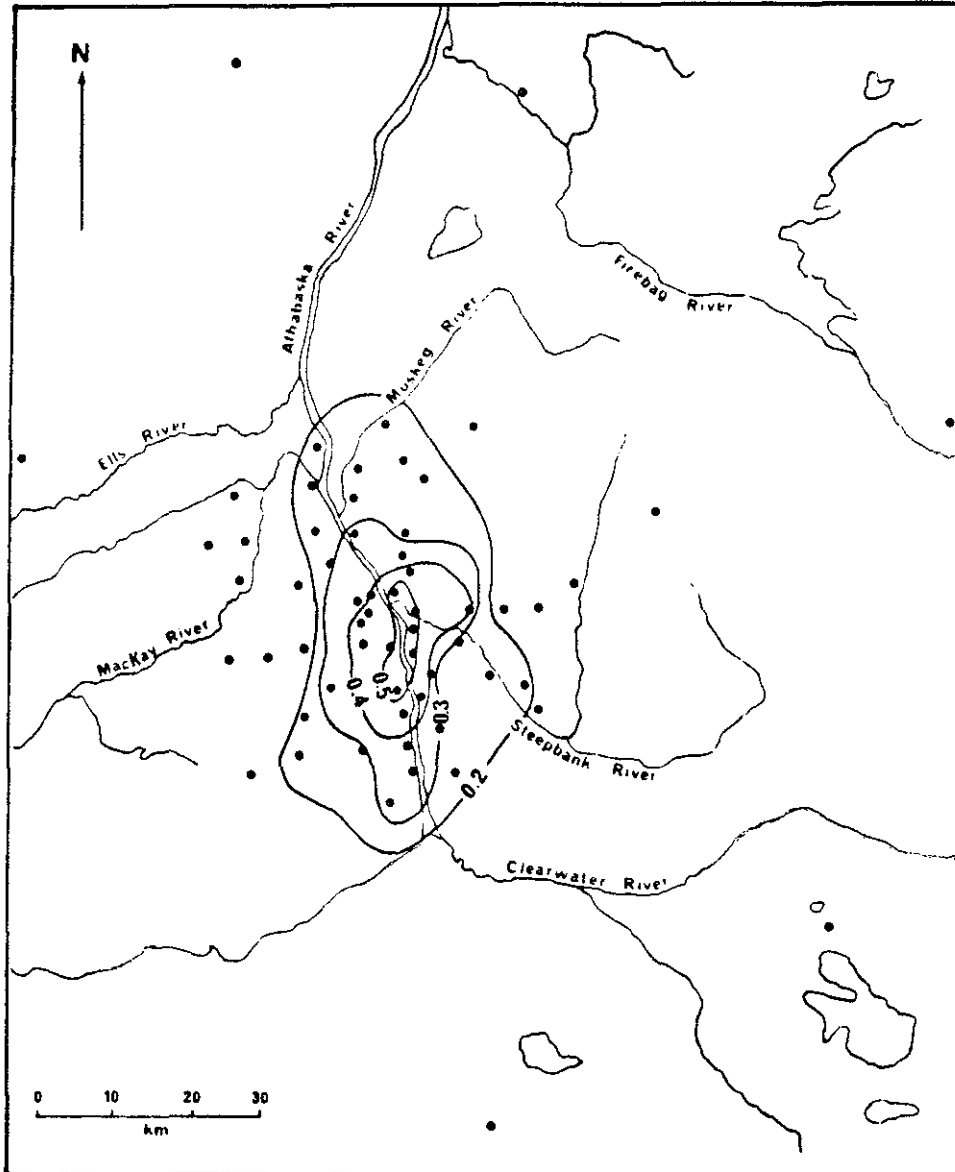

Figure 43. Annual isopleth (1978) for sulphate ion concentrations in snow samples in the AOSERP network.

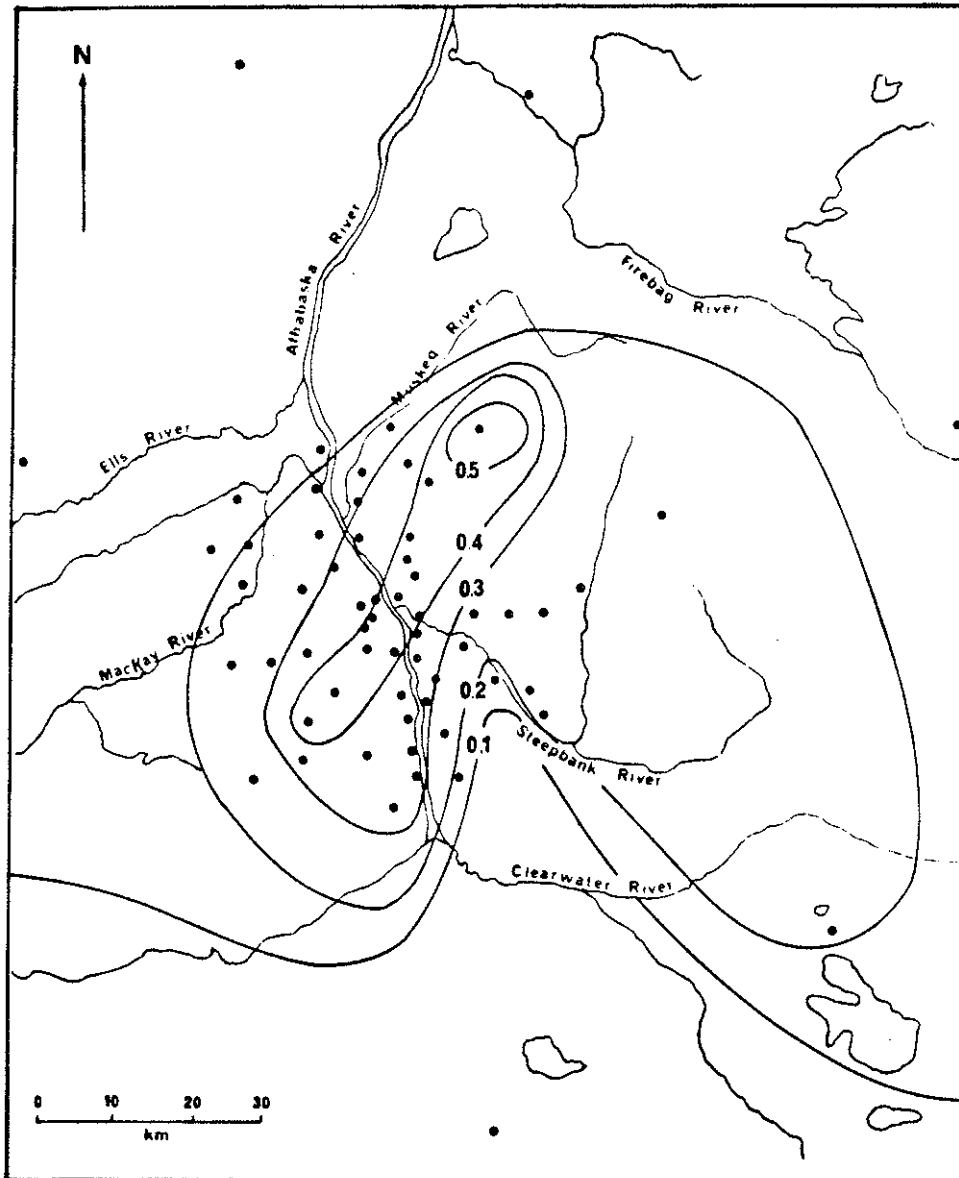

Figure 44. Annual isopleth (1981) for sulphate ion concentrations in snow samples in the AOSERP network.

of correlation among most snow parameters, only the isopleth for sulphate is illustrated. The isopleths in Figures 42 to 44 indicate spatial patterns that suggest dispersion along the valley axis. This pattern is consistent with prevailing valley winds. Similar dispersion patterns have been reported previously.

#### 5.4 INTERRELATIONSHIPS BETWEEN PARAMETERS

The analysis of inter-parameter relationships utilized factor analysis procedures. The application of this statistical technique to the data subsets is discussed for rain (Section 5.2) and snow (Section 5.3). An outline of these procedures is described in this section and results of the analyses for rain and snow data are given in sections 5.4.1 and 5.4.2 respectively.

The application of factor analysis to a data set is generally performed to resolve a set of variables linearly into a smaller number of categories or factors. The correlations among the variables are first determined, and this yields a matrix of correlation coefficients. Analysis of this matrix by one of several techniques generally yields a solution identifying a smaller number of common factors which convey the essential information of the original set of variables.

Further analysis of the correlation matrix can be performed using several techniques. The basic factor analysis model attempts to describe the variables  $z_j$  (e.g., the pH for each sample at each station) by a smaller number ( $m$ ) of factors,  $F_m$ , and a unique factor,  $Y$ , such that

$$z_j = a_{j1} F_1 + a_{j2} F_2 + a_{j3} F_3 + \dots + a_{jm} F_m + u_j Y_j$$

The  $m$  factors are the same for each of the  $j$  variables, but the linear equation relating the variables to the factors ( $F_m$ ) have different constants  $a_{jm}$  associated with each factor. The coefficients  $a_{jm}$  are termed the factor loadings. The factor analysis model is designed to maximally reproduce the correlation matrix.

The process of obtaining the factor loadings from the correlation matrix involves firstly replacing the diagonal elements of the correlation matrix (normally a value of unity) with estimates of the amount of variance that is within the common factor space. Next the matrix is diagonalized. In this process, a set of  $j$  eigen values are found. These eigen values essentially indicate the error content of the data by the corresponding eigen vectors. In practice a selected, convenient number of these eigen vectors are retained - the number selected is such that most of the total variance in the data is accounted for.

The variables selected for factor analyses included the following:

1. Location parameters for each station, namely GCDIST (distance from the reference point) and RELDIR (bearing in degrees from the reference point).
2. The "dissolved" (d) and "undissolved" (u) Al, Fe, Ni, and V concentrations.
3. pH,  $\text{NH}_4^+$ ,  $\text{NO}_3^-$ ,  $\text{PO}_4^{3-}$ ,  $\text{SO}_4^{2-}$ , conductance,  $\text{Ca}^{2+}$ ,  $\text{Cl}^-$ ,  $\text{K}^+$ ,  $\text{Na}^+$ ,  $\text{Mg}^{2+}$ .

Correlation coefficients among all possible pairs of stations were calculated and the correlation matrix format was used to summarize this information. The merged data for each sample will be referred to hereafter as records. Where replicate analyses were available, the mean was used. Records with an arbitrary minimum number of parameters (10 for rain and 10 for snow) were selected for factor analysis. All possible pairs of correlation coefficients were determined, and the resulting correlation coefficient matrices were used as inputs for factor analysis. The SPSS-X factor analysis routines were used since those procedures are more appropriate for this data set, which includes several missing parameters in each record. Some of the features of the correlation matrices are discussed, and it should be noted that they were used along with results of the factor analyses in selecting parameters for plotting.

Preliminary factor analysis identified up to 18 factors, of which the most important (six in the case of rain data and five in the case of snow) were selected for the final analysis.

#### 5.4.1 Factor Analysis for Rain Data

5.4.1.1 Correlation matrices. The correlation matrix of Pearson correlation coefficients is presented in Table 51. The parameter pairs with the strongest correlations are as follows:

- $\text{SO}_4^{2-}$  with  $\text{NO}_3^-$
- $\text{NH}_4^+$  and  $\text{NO}_3^-$ ,  $\text{SO}_4^{2-}$ , Fe (d)
- $\text{NO}_3^-$  with  $\text{SO}_4^{2-}$
- $\text{Cl}^-$  with  $\text{Na}^+$
- $\text{K}^+$  with  $\text{Na}^+$
- Ni(u) with  $\text{Mg}^{2+}$
- Fe(u) with  $\text{NH}_4^+$ ,  $\text{NO}_3^-$  and conductivity, Ni(u), V(u)
- Al(u) with Fe(u),  $\text{NH}_4^+$ ,  $\text{NO}_3^-$ , and conductivity
- Al(d) with V(d), V(u)

The parameters distance and direction did not have as strong correlations, although distance did have significant (at the 99% level of confidence) correlations with Al(u), V(u),  $\text{NO}_3^-$ ,  $\text{PO}_4^{3-}$ ,  $\text{SO}_4^{2-}$ ,  $\text{Ca}^{2+}$ , and  $\text{Cl}^-$ .

The strong correlations among the anions and cations are not surprising, and are reassuring. The rationale for correlations noted for Fe(u) and Al(u) are not immediately evident, while those between Al(u) and Fe(u) or Al and V(d) may be source-related. The correlation matrices, while providing reassurances in the cases of ions, provide relatively little additional insight into the data and its interpretation.

5.4.1.2 Factor analysis - rain data. Six factors were retained in the final analysis and accounted for 71% of the variability in the data. The parameters with the highest loadings for the factors are summarized below.

- |          |  |
|----------|--|
| Factor 1 | Al(u), Fe(u), Ni(u), V(u), $\text{NH}_4^+$ , $\text{SO}_4^{2-}$  |
| Factor 2 | Al(d), V(d), $\text{PO}_4^{3-}$ and (to a lesser degree) Fe(d), Ni(d), Ni(u), pH-1, conductance, $\text{Ca}^{2+}$ , $\text{Cl}^-$ , $\text{K}^+$ |
| Factor 3 | Ni(u), $\text{Cl}^-$ , $\text{K}^+$ , $\text{Na}^+$ , $\text{Mg}^{2+}$   |

Table 51. Pearson correlation coefficients.

	GDDIST	RELDOR	Al(d)	Al(u)	Fe(d)	Fe(u)	Nl(d)	Nl(u)	V(d)	V(u)	pH-l	NH <sub>4</sub> <sup>+</sup>	NO <sub>3</sub> <sup>-</sup>	PO <sub>4</sub> <sup>3-</sup>	SO <sub>4</sub> <sup>2-</sup>	COND	Ca <sup>2+</sup>	Cl <sup>-</sup>	K <sup>+</sup>	Na <sup>+</sup>	Mg <sup>2+</sup>	SVOL	
GDDIST	1.0000																						
RELDOR	-0.0632	1.0000																					
Al(d)	-0.0576	0.0823	1.0000																				
Al(u)	-0.2565	-0.2487	0.3620	1.0000																			
Fe(d)	-0.0856	0.0344	0.2259		1.0000																		
Fe(u)	-0.2469	-0.2476	0.4521	0.9818		1.0000																	
Nl(d)	0.1025	0.0513	0.2370	0.2146	0.0622	0.2494	1.0000																
Nl(u)	-0.0710	-0.0003	0.2916	0.5059		0.5515	0.2831	1.0000															
V(d)	0.0394	-0.0151	-0.6169	-0.0544	-0.3521	-0.0600	-0.1821	-0.0793	1.0000														
V(u)	-0.2208	-0.0807	0.3789	0.6962		0.5821	0.1198	0.4626	0.0700	1.0000													
pH-l	0.0847	0.1155	0.0410	0.0801		0.1061	0.2168	0.3585	-0.1420	-0.1392	1.0000												
NH <sub>4</sub> <sup>+</sup>	-0.0363	-0.1093	-0.0753	0.8696	0.4621	0.9027	-0.0468	0.1699	0.1085	-0.0167	-0.0502	1.0000											
NO <sub>3</sub> <sup>-</sup>	-0.1107	-0.1430	-0.2278	0.7245	0.3620	0.6165	-0.0651	0.0964	0.4176	0.2763	-0.1647	0.5851	1.0000										
PO <sub>4</sub> <sup>3-</sup>	-0.1145	-0.1162	-0.2897	0.4556	-0.0126	0.3516	-0.0772	-0.0375	0.4742	0.1586	-0.0671	-0.0354	0.3597	1.0000									
SO <sub>4</sub> <sup>2-</sup>	-0.1275	-0.1274	0.1071	0.3355	0.4307	0.3510	0.0671	0.1569	0.0261	0.4034	-0.2524	0.5692	0.5386	-0.0038	1.0000								
COND	-0.0041	-0.1094	-0.1368	0.7287	0.2886	0.7187	-0.0208	0.1127	0.2942	0.3083	-0.2903	0.2333	0.2724	0.2668	0.3008	1.0000							
Ca <sup>2+</sup>	-0.0854	0.0914	0.2938	-0.0368	0.3705	-0.0366	0.1766	0.3636	-0.1564	0.1696	0.1886	0.2228	0.1718	-0.0379	0.4020	0.0848	1.0000						
Cl <sup>-</sup>	0.1342	-0.0061	-0.1310	0.0978	0.0550	0.0826	0.1352	0.2607	0.2806	0.2708	-0.0263	-0.0457	-0.1147	0.0499	-0.1174	0.3204	0.0069	1.0000					
K <sup>+</sup>	-0.0027	-0.0855	-0.1978	0.1471	0.0787	0.1316	0.0080	0.3862	0.3668	0.0959	0.0279	0.0256	0.0526	0.1190	0.0653	0.2607	0.1944	0.3644	1.0000				
Na <sup>+</sup>	0.0186	-0.0719	-0.0646	0.1274	0.0539	0.1267	0.1724	0.4438	0.2311	0.1908	-0.0824	0.0031	-0.0410	-0.0072	-0.0038	0.3292	0.1293	0.4939	0.5520	1.0000			
Mg <sup>2+</sup>	-0.0055	0.0472	0.0150	0.0793	0.3134	0.0783	0.1838	0.4996	0.1624	0.2387	-0.0472	-0.0397	0.0262	-0.0364	0.0657	0.1964	0.3231	0.1838	0.4351	0.2708	1.0000		
SVOL	-0.0534	-0.0188	0.0311	-0.5447	0.2164	-0.2956	0.0000		0.0000			-0.0777	-0.1687	-0.0793	-0.1374	-0.1768	-0.1561	-0.1536	-0.0853	-0.1547	-0.1312	1.0000	



Factor 4 Fe(u),  $\text{SO}_4^{2-}$ ,  $\text{Ca}^{2+}$   
 Factor 5 pH  
 Factor 6 distance

The most important factor in terms of factor loadings is Factor 1, and the group of parameters includes  $\text{SO}_4^{2-}$  and V, which are likely to be source-dependent.

It is natural to seek a factor that includes a high loading for the distance variable, thereby strongly indicating a source-related factor. In this regard it may be noted that the variable distance had a moderate loading (with the sign opposite to the loadings for the other variables) with Factor 1, so Factor 1 more than any other is implicated as the most likely source-related factor and reflects the expected inverse relationship between concentration and distance from the source. In addition, distance loaded strongly by itself in Factor 6.

The bases for the groupings of the parameters in the other factors are not very revealing or convincing, although the parameters in Factor 2 may be point source-related, while for Factor 3 they may be indicative of background sources. These hypotheses are not substantiated by any other evidence.

#### 5.4.2 Factor Analysis for Snow Data

5.4.2.1 Correlation matrices. In the case of snow data, records with 11 or more parameters for the years 1978, 1981, 1983, and 1984 were included in the analysis. The correlation matrix for these data (Table 52) showed the strong correlations between most pairs of parameters. The following pairs of parameters showed the least correlations:

- direction with all parameters
- distance with all parameters except Al(u), V(d), V(u)
- Al(d) with all parameters except Ni(d)
- Al(u) with all parameters except Fe(d), Ni(d)
- Fe(d) with all parameters
- Fe(u) with Ni(d)

Table 52. Correlation matrices for snow data.

	GODIST	RELDOR	Al(d)	Al(u)	Fe(d)	Fe(u)	NI(d)	NI(u)	V(d)	V(u)	pH-I	NH <sub>4</sub> <sup>+</sup>	NO <sub>3</sub> <sup>-</sup>	SO <sub>4</sub> <sup>2-</sup>	COND	Ca <sup>2+</sup>	Cl <sup>-</sup>	K <sup>+</sup>	Na <sup>+</sup>	Mg <sup>2+</sup>	Ak(k)	
GODIST	1.0000																					
RELDOR	-0.11662	1.0000																				
Al(d)	-0.09121	0.09725	1.0000																			
Al(u)	-0.47718	-0.00800	0.09342	1.0000																		
Fe(d)	-0.15733	0.10189	0.32720	0.18910	1.0000																	
Fe(u)	-0.44995	0.08818	0.08205	0.96719	-0.23980	1.0000																
NI(d)	0.04901	0.06177	0.70578	0.92496	-0.38711	0.27883	1.0000															
NI(u)	-0.48806	-0.13669	0.06344	0.83626	0.20263	0.67212	0.31039	1.0000														
V(d)	0.54309	-0.03984	0.17161	0.63185	0.24150	0.58865	0.02231	0.89847	1.0000													
V(u)	-0.47291	-0.12100	0.06550	0.84533	0.22322	0.68839	0.30430	0.99723	0.89004	1.0000												
pH-I	0.25473	0.07406	0.11991	0.75673	0.18469	0.83183	0.31021	0.59557	0.45633	0.60472	1.0000											
NH <sub>4</sub> <sup>+</sup>	-0.26136	-0.03956	0.07279	0.70585	0.19921	0.68017	0.18915	0.65823	0.59535	0.64831	0.32175	1.0000										
NO <sub>3</sub> <sup>-</sup>	-0.08792	0.03154	0.06996	0.56463	0.23974	0.55913	0.21218	0.56285	0.59127	0.55726	-0.52159	0.39094	1.0000									
SO <sub>4</sub> <sup>2-</sup>	-0.48923	0.00103	0.04325	0.86581	0.27928	0.89446	0.26962	0.72273	0.70732	0.72255	0.64294	0.55763	0.05085	1.0000								
COND	-0.36720	0.03396	0.06732	0.71468	0.24838	0.72374	0.18351	0.64645	0.66590	0.64225	-0.03665	0.49525	0.67094	0.60818	1.0000							
Ca <sup>2+</sup>	-0.37342	0.05924	0.11602	0.83782	-0.03724	0.88925	0.56801	0.64470	0.56271	0.64806	0.74379	0.43492	-0.09573	0.91879	0.44347	1.0000						
Cl <sup>-</sup>	0.35341	0.02686	0.08798	0.57782	-0.10287	0.64474	0.87130	0.50127	0.52135	0.48829	0.53861	0.28092	-0.12489	0.65618	0.32819	0.64404	1.0000					
K <sup>+</sup>	-0.21408	0.01213	0.02069	0.59401	-0.00216	0.58914	0.36171	0.52101	0.42319	0.51676	0.59840	0.25315	-0.21829	0.59624	0.19976	0.69978	0.57534	1.0000				
Na <sup>+</sup>	0.28982	-0.01864	0.09220	0.67354	-0.00266	0.66030	0.44961	0.63570	0.49921	0.64249	0.60699	0.40524	-0.08276	0.79242	0.43471	0.76236	0.74663	0.63228	1.0000			
Mg <sup>2+</sup>	-0.35959	0.10492	0.07745	0.77406	-0.04482	0.85301	0.16553	0.52941	0.45113	0.53147	0.70370	0.37808	-0.06096	0.84295	0.48558	0.92442	0.65334	0.71299	0.74100	1.0000		
Ak(k)	-0.30231	0.13692	0.17299	0.78439	-0.18875	0.82421	0.32307	0.57888	0.38702	0.58399	0.88064	0.72861	0.49373	0.82686	0.66080	0.84027	0.58447	0.64437	0.66261	0.82460	1.0000	

- pH with conductance,  $\text{NH}_4^+$
- $\text{NO}_3^-$  with most parameters except alkalinity and conductance
- alkalinity with Fe(d)

The strong correlations are an assurance that the data set is consistent and that concentrations show an inverse relation with distance (the correlation coefficients involving distance were all negative). The surprising feature of the correlations is the behaviour of  $\text{NO}_3^-$ , which was expected to be like the other ions.

5.4.2.2 Factor analysis - snow data. The preliminary analysis indicated that five factors explained most of the variability and therefore only these were retained. These factors accounted for 84% of the variability in the data, but even so, one factor predominated (accounting for 50% of the variability).

For this factor, the factor loadings for all variables except direction, Al(d), Fe(d), Ni(d), and  $\text{NO}_3^-$  were high. This factor is clearly point source-related (the loading for distance had a sign opposite to those for the other parameters).

The second factor showed high loadings for  $\text{NO}_3^-$ , alkalinity, Al(u), Fe(u), Ni(u), V(d), V(u), and conductance. The basis for this factor is not clear.

Only Al(d) and Ni(d) loaded strongly on the third factor, Fe(d) on the fourth, and direction on the fifth. The third, fourth, and fifth factors probably reflect peculiar analytical features (Factors 3 and 4), or the poor directionality of the data, or indeed validity for including direction as a variable. Since the latter four factors accounted for 21% of the variability in the data, it is clear that the snow data are dominated by the source-related factor (Factor 1) for most species except  $\text{NO}_3^-$ , Al(d), Ni(d), and Fe(d).

## 5.5 EPISODIC RAIN EVENTS

Rain episodes, which are defined as periods during which elevated concentrations of ions in rain samples occur, were identified and characterized in terms of the major synoptic scale meteor-

ological features. For the purposes of this study, the criteria used to define episodes are based on the occurrence of elevated levels of the major ionic species in rain samples at four or more stations. The species selected were pH,  $\text{SO}_4^{2-}$ ,  $\text{NO}_3^-$ ,  $\text{Cl}^-$ ,  $\text{NH}_4^+$ ,  $\text{Na}^+$ , and  $\text{K}^+$ .

Identification of episodes involved selecting the upper 15% of the data for the above parameters and merging and sorting these data by date and station. Dates on which four or more different stations had rain samples with concentrations for one or more of the selected species in the upper 15% of the distribution were identified. Within each year, the dates on which the highest concentrations of sulphate and/or hydrogen ion occurred were then selected for detailed analysis. This methodology is somewhat arbitrary, but does provide periods in each year when rain samples had high concentration levels.

The episodes identified are listed in Table 53. The analysis involved examination of synoptic weather maps for the episode days (as well as relevant preceding days as cases warranted), and analysis of relevant meteorological data for the periods in order to characterize the synoptic scale features of episodes.

#### 5.5.1 Synoptic Weather Analysis for Selected Wet Deposition Periods

A summary of the synoptic weather patterns for the selected wet-deposition episode days listed in Table 53 is given in Chapter 8.15. These patterns were abstracted from the synoptic weather maps for 1200 GMT (0500 MST) on the day in question. Past histories and future situations were either derived from synoptic maps before or after the 1200 GMT map or from storm track summaries.

#### 5.5.2 Cyclone Climatology of Northeastern Alberta - May to September

The climatology of cyclones in the northeastern Alberta region for the May to September period has been abstracted from reports by Klein (1957) and Whittaker and Horn (1982), hereafter designated as K and WH respectively. Three aspects of cyclone climatology are addressed: frequency of cyclones in the five-degree

Table 53. List of episodic rain events.

Year	Month	Day
1984	08	06
1984	08	04
1984	06	29
1984	06	05
1984	06	01
1982	08	06
1982	08	11
1982	05	17
1982	05	16
1982	05	15
1982	05	14
1981	09	01
1981	08	12
1981	07	05
1981	05	17
1979	07	31
1979	08	01
1979	08	02

sectors of 55 to 60°N and 110 to 115°W, frequency of cyclone formation (cyclogenesis) in this sector, and the primary and secondary storm tracks relevant to this area of Alberta.

The average number of cyclones traversing the northeastern Alberta sector for each month in the May to September period as reported by Klein (1957) and Whittaker and Horn (1982) is given in Table 54, as is the average number of cyclones originating in this sector each month. The northern Rockies is one of the prime areas of cyclogenesis in North America. Cyclogenesis in the lee of the Rockies occurs primarily along the British Columbia border and in southern Alberta during May, June, and July. In August, all of Alberta except the Lake Athabasca region is a primary cyclogenetic zone. In September, this zone shrinks to the eastern half of Alberta.

Climatological storm tracks are the preferred path of cyclone motion across the hemisphere. Those tracks, both primary and secondary, that traverse close enough to likely influence the weather of northeastern Alberta are summarized below.

The predominant storm track is consistent with the geostrophic winds (850 mb, Mildred Lake) which occur most frequently from the northwest (Davidson et al. 1981) or the west-northwest (550 m Stony Plain), Leaky et al. 1982. In contrast, examination of lower level wind data (Mildred Lake, 10 m) clearly shows the influence of the terrain in orienting the wind and the predominant wind directions are along the axis of the Athabasca river valley (Hansen et al. 1984), although the 10 m winds at Birch Mountain are similar to winds at 850 mb (1200 m). It was anticipated that concentration isopleths may have illustrated the effects of prevailing winds, but the uncertainties in the data render such evaluation tenuous.

## 5.6 SOURCE REGIONS AFFECTING AOSERP PRECIPITATION

The analysis of the synoptic scale features of episodic rain events and an examination of climatological storm tracks have indicated the following:

Table 54. Cyclone frequency and genesis in a sector of northeastern Alberta (55 to 60°N, 110 to 115°W).

Month		Average Number of Cyclones Traversing per Month		Average Number of Cyclones Originating per Month	
		Klein 1957	Whittaker-Horn 1982	Klein 1957	Whittaker-Horn 1982
May	Primary - from the central Alberta-Saskatchewan border east-southeastward (K). From north of the British Columbia-Alberta border southeastward through an area south of Lake Athabasca (WH).  Secondary - from the northern Yukon southeastward to Lake Athabasca and the Gulf of Alaska to central Alberta (K). None (WH).	1.45	2.05	0.20	0.05
June	Primary - from the central Alberta-Saskatchewan border eastward (K). From the southern Alberta-Saskatchewan border eastward (WH).  Secondary - from the northwest Yukon southeastward to central Alberta (K). From northern Alaska southeastward through Lake Athabasca (WH).	1.50	2.00	0.35	0.10
July	Primary - from north of the northeastern Alberta-British Columbia border east-southeastward to Lake Athabasca (K). From the southern Alberta-British Columbia border east-northeastward (WH).  Secondary - from northern Alaska to the area of the southern Yukon-northwestern Alberta and northeastern British Columbia and the Gulf of Alaska northeastward to the Yukon-British Columbia border (K). Same (WH).	1.30	2.25	0.30	0.20
August	Primary - from the northern Alberta border southeastward (K). From the vicinity of south central Alberta east-southeastward (WH).  Secondary - from southwestern Alberta northeastward (K). From the northern Alaska-Yukon shoreline southeastward through the area of the Alberta-Saskatchewan-Northwest Territories border (WH).	1.25	2.15	0.45	0.30
September	Primary - from north-central Alberta eastward (K). From southern Alberta eastward (WH).  Secondary - from the Alaska-Yukon border to the northern Alberta-British Columbia border and from the Gulf of Alaska eastward to east-central Alberta (K). From north of the Alberta-British Columbia border southeastward through the area north of Lake Athabasca (WH).	1.35	2.00	0.40	0.15

1. Most episodes implicate sources within the AOSERP study area.
2. Climatological storm tracks generally originate from the quadrant centred on the northeast and follow a eastern to southeastern path.

Attempts to resolve the contributions to an area's wet (and dry) deposition chemistry by different sources is the subject of intense scientific study, and has been more successful in the case of dry deposition. Such resolution of the source contributions requires a network with consistent and reliable data and the characterization of source-specific tracers. The database available in the present study is inadequate to warrant detailed analyses. Instead, a brief discussion of the potential sources and the resolution of their relative importance is presented.

#### 5.6.1 Local Sources

The local sources are the two oil sands plants, local soil contributions and, to a lesser extent, contributions from urban (Fort McMurray) emissions. The oil sands plants dominate these local sources, although accurate data on emissions from Fort McMurray are not available. There was no indication of any other local sources (such as a soil source) as discussed in Section 5.4.

The areas to the northwest and west of the study area are those most likely to have an impact on AOSERP precipitation chemistry. Thus the urban centres to the south (Edmonton, Calgary) and the sour gas and thermal generating industries to the west of the Rocky Mountains are not likely to have much of an impact on the study area (See Figure 45). There are three gas processing plants in the area to the northwest on the Alberta-British Columbia border that have potential for affecting the AOSERP area. There is, however, no evidence to quantify the importance (if any) of these sources.

#### 5.6.2 Summary

For many of the episodes of wet deposition described in this section, precipitation resulted from local convective activity,



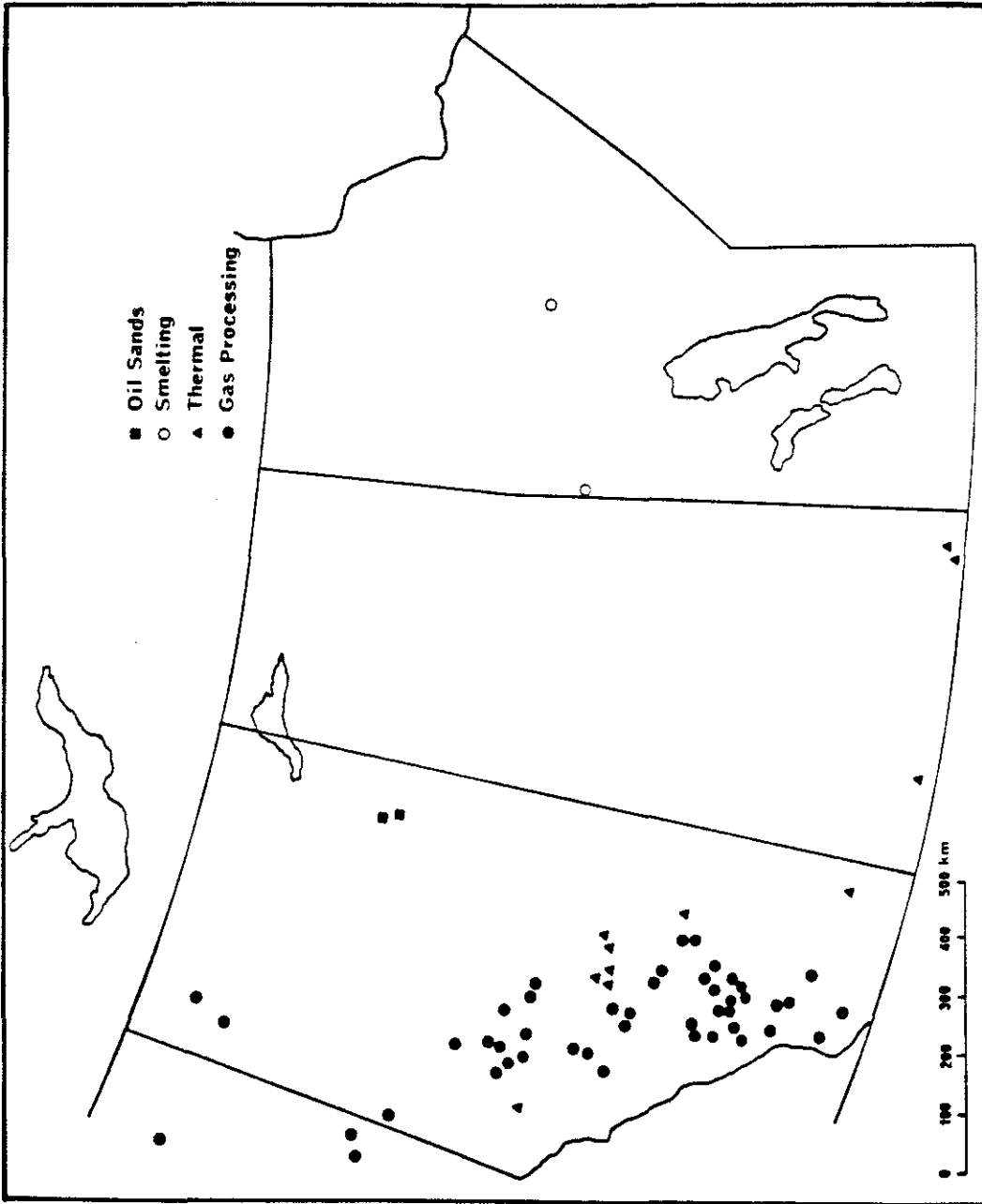

Figure 45. Emission sources of potential impact on the AOSERP area.

the early stages of cyclone formation (cyclogenesis), or stationary or slow-moving cyclones. It is therefore difficult to construct detailed back-trajectories of air motions. Patterns of elevated concentrations of one or more constituents of the rainfall suggest that local sources such as the Suncor and Syncrude operations, the city of Fort McMurray, and surrounding agricultural activity may be the primary sources of anthropogenic ions in the precipitation. More detailed studies are required, however, to establish the degree of contribution of these sources to the local rainwater chemistry.

The high frequency of episode days with low pressure systems forming or passing through the AOSERP region of Alberta suggests that the cyclone climatologies cited in this report may be useful in estimating the potential number of days with high concentrations over long time periods. Further work along these lines is suggested.

#### 5.7 HISTORICAL AND PROJECT POINT SOURCE EMISSIONS AND PRECIPITATION QUALITY

One of the objectives of the study was to attempt to establish a historical relationship between emissions from the two major point sources (the Syncrude and Suncor oil sands plants) and the precipitation quality with respect to sulphate levels. Should such a relationship be found, then sulphate levels in future years may be estimated given emission scenarios. It should be stressed that a more rigorous approach to making such estimates would rely on dispersion modelling techniques, but such an approach was not required for this contract.

The requirement was for examination of concurrent emission and precipitation levels to seek any relationship between these parameters. The most suitable parameter to indicate precipitation quality is the volume weighted mean concentration or the closely related deposition measured in grams  $\text{SO}_4^{2-}$  per unit area. Unfortunately, the sampler collection efficiencies throughout the network's history have been poor, hence calculations incorporating rain volumes collected would be in error. Nevertheless, volume weighted

mean sulphate concentrations were calculated for each station on a monthly basis (by totalling the products of individual concentration and rain volume collected and dividing the sum by the total monthly rainfall). These data are tabulated along with the station average of the volume weighted mean concentration, which may be taken to represent a network-wide average (volume weighted) concentration.

Monthly emission data from the oil sands plants were totalled and charted along with the station mean of the volume weighted sulphate concentration (Figure 46). The data are shown in Table 55. The emission levels vary in concert with sulphate rain concentration for the sampling periods in 1981 and less so in 1984, but the pattern in 1982 was not indicative of a relationship between the parameters. It should be stressed that in view of the poor collection efficiencies, more detailed analysis is not warranted. The data however do provide encouragement that the volume weighted means may likely reflect emission levels.

A similar analysis for snow data would require analogous precipitation data (monthly snowfall amounts along with corresponding analytical data or segmented core analyses along with monthly or event-based precipitation data). The available snowcore data included only mean concentration data with no precipitation data, though snow depth and snowcrust depth data were available. It was not feasible therefore to include the snow deposition data in Figure 46. It should be noted that the 1982 data were sparse since considerable amounts of data failed to meet the screening criteria in that year and that the 1984 snow depth data were not included in the raw data files, although sampling protocols indicated that such measurements were made.

The analysis of the deposition patterns in the study area has suffered greatly from lack of adequate data.

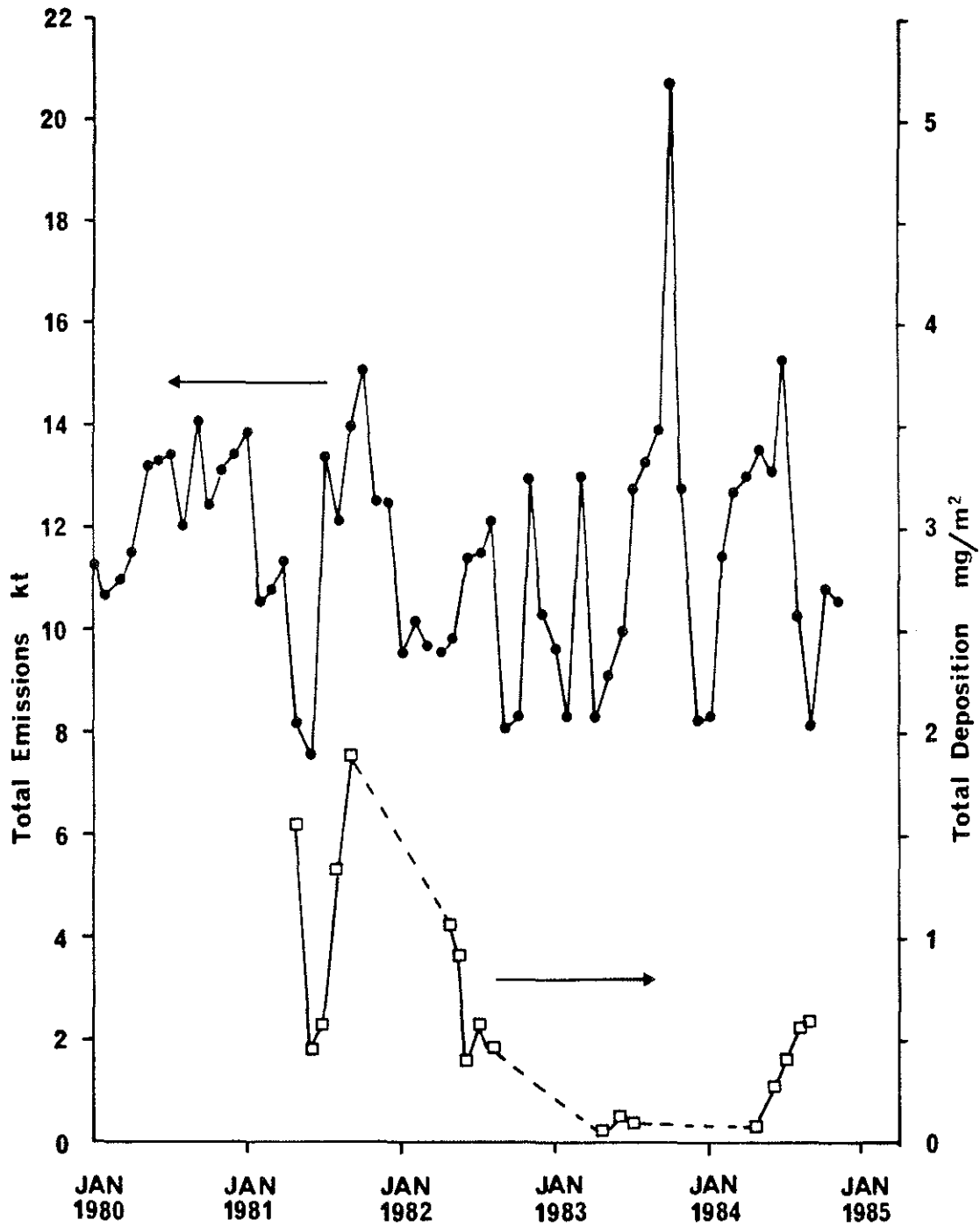

Figure 46. Monthly total emissions (●) and volume weighted monthly means (□) for  $\text{SO}_4^{2-}$  in the AOSERP network.

Table 55. Monthly total emissions (t) and volume weighted monthly means for SO<sub>4</sub><sup>2-</sup> (mg/m<sup>2</sup>) at individual stations in the AOSERP network.

Year	Month	Total Emissions	Site #5 Birch Mt.	Site #15 Elis Tower	Site #28 Grande Tower	Site #29 Gordon Lake	Site #32 Fort Hills	Site #34 Johnson	Site #35 Keane Creek	Site #41 Lost Creek	Site #47 Muskeg Mt.	Site #51 Mildred Lake	Site #103 Stony Mt.	Site #115 Thickwood Hills	Site #95 Sandalta	Mean
1980	January	11 647														
1980	February	10 665														
1980	March	10 858														
1980	April	11 530														
1980	May	13 239														
1980	June	13 301														
1980	July	13 437														
1980	August	11 883														
1980	September	14 074														
1980	October	12 365														
1980	November	130 975														
1980	December	13 392														
1980	Grand Total	267 366														
1981	January	13 925														
1981	February	10 598														
1981	March	10 713														
1981	April	11 524.6														
1981	May	8 183.8	2.471	1.74	0.820	1.85	3.225	1.260	0.090	2.010			1.37	0.390		1.53
1981	June	7 534	0.168	0.095	0.522	0.924	0.878	0.345	0.512	0.017	0.408	0.032	0.608	0.455		0.414
1981	July	13 459	0.425	0.986	0.494	0.284	2.090	0.004	0.512	0.607	0.928		0.789	0.578		0.663
1981	August	12 041		0.430	0.724	1.79			1.590		1.560		0.670	2.785		1.36
1981	September	13 962		0.870	0.350	0.950							6.570	0.623		1.87
1981	October	15 167														
1981	November	12 524														
1981	December	12 477														
1981	Grand Total	141 908.4														

continued ...

Table 55. Continued.

Year	Month	Total Emissions	Site #5 Birch Mt.	Site #15 Elis Tower	Site #28 Grande Tower	Site #29 Gordon Lake	Site #32 Fort Hills	Site #34 Johnson	Site #35 Keane Creek	Site #41 Lost Creek	Site #47 Muskeg Mt.	Site #51 Mildred Lake	Site #103 Stony Mt.	Site #115 Thickwood Hills	Site #95 Sandalfa	Mean
1982	January	9 503														
1982	February	10 193														
1982	March	9 738														
1982	April	9 579														
1982	May	9 803	0.750	1.195	0.566	0.860	1.320	1.785	1.143	1.024	1.09	1.68	0.724	1.26	ND	1.12
1982	June	11 383	0.320	0.183	0.205	0.460	1.254	0.643	0.991	0.561	0.59	1.22	1.05	0.611	ND	0.83
1982	July	11 498	0.518	0.462	0.387	0.507	0.210	0.117	0.492	0.253	0.439	0.21	0.185	0.879	ND	0.39
1982	August	12 229	0.271	1.092	0.177	0.317	0.684	0.832	2.253	0.097	0.789		0.194	0.760	ND	0.69
1982	September	8 051	0.435			0.414		0.385	0.046				0.580	0.580	ND	0.41
1982	October	8 314														
1982	November	12 979														
1982	December	10 300														
1982	Grand Total	123 570														
1983	January	9 579														
1983	February	8 337														
1983	March	13 078														
1983	April	8 282														
1983	May	117														
1983	June	9 869														
1983	July	12 764													0.024	0.024
1983	August	13 323													0.123	0.123
1983	September	13 942													0.031	0.031
1983	October	20 819													0.024	0.024
1983	November	12 754													0.123	0.123
1983	December	8 232													0.031	0.031
1983	Grand Total	131 096														

continued ...

Table 55. Concluded.

Year	Month	Total Emissions	Site #5 Birch Mt.	Site #15 Ells Tower	Site #28 Grande Tower	Site #29 Gordon Lake	Site #32 Fort Hills	Site #34 Johnson	Site #35 Keane Creek	Site #41 Lost Creek	Site #47 Muskeg Mt.	Site #51 Mildred Lake	Site #103 Stony Mt.	Site #115 Thickwood Hills	Site #95 Sandelta	Mean
1984	January	8 325														
1984	February	11 421.7														
1984	March	12 715														
1984	April	13 004														
1984	May	13 604												0.078		0.078
1984	June	13 132	0.415	0.351	0.008	0.365	0.273	0.634	0.123	0.167	1.50	0.411	0.452	0.074	0.331	0.39
1984	July	15 345	0.334	1.43	0.212	0.125	1.037	0.508	0.140	0.229	0.122	0.077	0.094	0.907	0.488	0.41
1984	August	10 252	0.200	0.315	1.188	0.348	0.474	0.611		0.875	1.281		0.033	0.384	0.315	0.547
1984	September	8 128												0.550		0.550
1984	October	10 921														
1984	November	10 921														
1984	December	ND														
1982	Grand Total	127 464.7														

ND - no data available

## 6. CONCLUSIONS AND RECOMMENDATIONS

The major conclusions arising from the evaluation and assessment of the operation of the AOSERP network and from the analysis of data generated in the network are summarized in this chapter. The tasks that allowed these assessments were as follows:

1. Transformation of the existing free format data into a consistent format;
2. Evaluation of the data by application of screening procedures and assessment of field and laboratory procedures of the network's operation;
3. Statistical analysis of the quality assurance and quality control data generated throughout the network's operation;
4. Statistical analysis of the monitoring data to determine spatial and temporal trends and interparameter relationships; and
5. Preliminary assessment of the likely impact of future emissions on precipitation chemistry in the study area.

In addition, recommendations for improvements in the field operation and in data processing aspects of the network activities are presented.

### 6.1 DATABASE ASPECTS

The transformation of the data into a consistent format has been accomplished. The raw data have been transformed into a fixed format file and, in addition, the data have been screened and the resulting categories of data have been placed in separate files. Data meeting the screening criteria were placed in screened arrays, and the remainder in a suspect file (of the same format). The attributes of the data with respect to screening have been recorded in a flag file with a format similar to that in the raw and screened arrays. In addition, the raw data and the screened data have been converted into a format that is consistent with the NAQUADAT database.



The file conversion took place on a file-by-file basis which in the case of the NAQUADAT database is unimportant, but for statistical analysis, considerable merging of data was necessary since there were often replicate records with different types of information about the same sample. The multiplicity of files and the inconsistent formats therein presented significant problems for the file conversion process. The most severe of these problems as far as subsequent data analysis was concerned were the lack of complete analytical data on samples, the lack of complete information or incorrect sample dates, and the lack of data on precipitation amounts (volume of rain sample collected or snow depth). The latter deficiencies, in addition to the variable collection efficiencies, limited the evaluation of deposition estimates. Other problems required extensive editing of the raw data and the customizing of software to allow conversion of each file.

## 6.2 DATA EVALUATION

### 6.2.1 Screening

The screening techniques applied to the data identified outliers (values greater than two standard deviations from the mean) and samples in which selected groups of ionic species had simultaneously high values or in which the anion/cation ratio (A/C) fell outside of the prescribed range ( $0.5 < A/C < 1.5$ ).

On average about 3% of data in each year were flagged as outliers except in 1984, where 15% of rain data and 8% of snow core data were flagged, and in 1981, where over 60% of the data were excluded due to low A/C ratios or simultaneous occurrence of high ionic concentrations. The incidence of simultaneously high values for certain parameters was low ( $< 3\%$ ) except for 1981 snow data, and the coincidence of high  $\text{Ca}^{2+}$  and  $\text{Mg}^{2+}$ , typical of soil contamination, was low. Missing data for ionic species precluded the application of A/C screening procedures in several cases, specifically in 1981 snow data.

### 6.2.2 Sample Collection Aspects

The collection efficiencies of rain samplers were determined, but the daytime only sample collection schedule rendered the collection efficiencies invalid in cases where rainfall occurred at night. Only 30% of the daily sampler efficiencies were greater than 75%. The variable efficiencies observed reflect the incomplete collection (low efficiencies) as well as other problems associated with poor sampler or operator performance (high and variable efficiencies). The lack of sampler evaluation studies (to characterize sampler collection efficiencies) and more detailed time resolved standard rain gauge data preclude resolution of the causes for the poor collection efficiencies. In view of the low sample collection efficiencies, the reliability of the rain data in describing wet deposition is low.

In collecting snow samples, the occurrence of thaw periods prior to or during sampling has the potential for leaching pollutants from the snow deposit, thereby causing inaccuracy in estimates of the deposition process. In 1984, the likelihood of such an effect was very great, while in 1976, 1981, and 1983 it was low. In 1976, temperatures were consistently low, so leaching effects were not at all likely.

The lack of snow depth data in 1981, 1983, and 1984, the absence of historical snowfall data, and the lack of accurate dates on which samples were taken preclude the detailed analysis of snow deposition.

Current techniques and protocols for precipitation sampling clearly lead to unreliable estimates for deposition of all parameters.

### 6.2.3 Analysis of Duplicate and Replicate Data

One intensive quality assurance/quality control programme was conducted in the network's history, and other QA/QC activities were limited to analysis of split and spiked samples. There were some interlaboratory studies, but these were poorly documented and evaluated and routine QA/QC samples were inadequate. The major

conclusions derived from the available data are as follows:

1. In the 1983 QA/QC programme, the only one in which blank data were routinely available, the levels of  $\text{NH}_4^+$ ,  $\text{Ca}^{2+}$ , and  $\text{Mg}^{2+}$  approached or exceeded acceptable levels relative to those in samples (> 10%).
2. Data for co-located samplers (1983 study) were generally good for  $\text{SO}_4^{2-}$ -S,  $\text{NO}_3^-$ , conductivity, pH,  $\text{Ca}^{2+}$ , and  $\text{Mg}^{2+}$ , but lower for  $\text{NH}_4^+$ ,  $\text{Na}^+$ , and  $\text{Cl}^-$ , with some bias for  $\text{Cl}^-$ . Unfortunately, the 1983 study did not include the detailed measurements of sampler collection efficiencies.
3. Statistical analyses of replicate or duplicate data generated in other years were also conducted. Of all species,  $\text{Na}^+$  had the highest variability, while other parameters analysed in the same sample aliquot showed less variability.
4. Information attesting to the operation of laboratory QA/QC practices was unavailable, which indicates that timely data validation was not a feature of the network's operation.

### 6.3 ASSESSMENT OF LABORATORY AND FIELD OPERATIONS

#### 6.3.1 Laboratory Operations

There was lack of information required to evaluate many aspects of the laboratories' performance. The sample reception and handling procedures within the laboratories were undocumented, save for the 1984 period during which the Chemex laboratory analysed samples. While the analytical methods used were acceptable insofar as their sensitivity, reliability, and suitability were concerned, there was little if any information on laboratory QA/QC programs. The QA/QC samples that were consistently generated were restricted to analyses of spiked samples and within-run duplicates. Suitable blanks were generated in 1983 and 1984, and reference was made to

round-robin studies in 1976, 1977, 1981, and 1984, but data from these studies were not well documented.

Sample handling protocols for snowcore analyses varied throughout the period, but procedures improved significantly in 1984. Sample storage and documentation of laboratory protocols were aspects of the operation that needed and did show improvement in 1984.

### 6.3.2 Field Operations

The evaluation of field operations for rain and snowcore sampling constituted a major component of the work program. The evaluation considered siting criteria, site suitability and representativeness, the logistics of sample collection and transport, and the implications of these activities for data quality.

Stated siting criteria purportedly were based in part on the Ontario APIOS siting criteria, which is concerned with background rather than point-source related sampling. The AOSERP sites are well distributed around the major point sources. Evaluation of sites was in part limited by the incompleteness of site documentation (specific siting information missing, incomplete, or outdated, or inadequate site drawings). Six sites with unacceptable surroundings have been identified.

## 6.4 STATISTICAL ANALYSIS OF MONITORING DATA

### 6.4.1 Temporal and Spatial Patterns

Attempts were made to elicit temporal and spatial patterns in the data and also to characterize interparameter relationships.

Annual frequency distributions for network-wide concentrations of selected parameters in rain and snow were determined and illustrated in box plots indicating concentrations corresponding to various percentiles. Given the fact that there were major differences in the data from year to year (numbers of stations, sampling and analytical methods), detailed analysis of the data for trends is not warranted. There was some indication that the annual means for the concentrations of sulphate and ammonium and for conductivity

increased with time, but it should be noted that the data each year overlapped considerably and definite trends in the data cannot be established. In the cases of sodium, potassium, and conductivity, there was a general increasing pattern in the percentiles between 1976 and 1979, but thereafter the values for conductivity were lower and, in the cases of sodium and potassium, much less scattered. Calcium concentrations showed great variability.

In general, annual and monthly mean concentrations for selected parameters at selected stations reflected the network-wide patterns but again, the overlap in the data from year to year precludes firm conclusions about trends.

Maps showing isopleths of concentration values for selected parameters were prepared, but in view of the very large degree of overlap (the standard deviations would include two or more adjacent isopleth lines), the plots have little significance.

#### 6.4.2 Interparameter Relationships

The determination of interparameter relationships was based on the calculation of correlation coefficients among 22 parameters. The strongest correlations were among the major ions and were consistent with precipitation chemistry. A distance parameter (between the station and the mid-point between the Syncrude and Suncor plants) showed relatively lower correlations with ions or metals, but some correlations were significant (at the 99% level of confidence) with V, Al,  $\text{SO}_4^{2-}$ ,  $\text{Ca}^{2+}$ ,  $\text{PO}_4^{3-}$ , and  $\text{Cl}^-$ . In the case of snow data, the correlations among ions were stronger than similar correlations in the rain data.

Factor analyses of the rain and snow data (separately) were carried out based on data subsets (records with at least 10[rain] or 13[snow] parameters). In the case of snow, there was a single dominating factor, which indicated point-source influence. The rain data also showed a similar factor, but its dominance was not as great. The rain data pointed to five other factors of decreasing significance, none of which could be readily explained. There was some indication of another point source-related factor and a factor indi-

cating background (soil?) sources. The surprising feature of the factor analysis of the snow data was the behaviour of  $\text{NO}_3^-$  and to lesser extents Fe and Ni, none of which had high loadings with the distance-related factor.

#### 6.5 EPISODIC RAIN EVENTS

Episodic rain events were identified based on the occurrence of high concentrations (in the upper 15th percentile of their distributions) of selected parameters at four or more stations. Representative periods in each year were selected and the synoptic features for those days were analysed.

Most episodes resulted from local convective activity, the early stages of cyclone formation, or stationary or slow-moving cyclones. Such features made construction of detailed back-trajectories difficult. The patterns of ionic concentrations implicate the local sources, but their resolution (relative contribution) was not possible.

A review of climatological storm tracks for the area indicated that passage along southeast to east paths is most frequent. Urban centres to the south and the thermal generating and gas processing plants along the eastern foothills and farther east are not likely to influence AOSERP study area precipitation. The northernmost Alberta-British Columbia border area would therefore be the most important upwind source region, but there was no evidence for long-range transport contributing to episodes. There are gas processing plants in that region, but their emissions are small relative to the local AOSERP study area sources.

#### 6.6 HISTORICAL AND FUTURE EMISSIONS

Examination of historical emission data along with volume weighted mean concentration data or deposition data may allow some indication of the impact of emissions on precipitation quality. The lack of sample volume data prior to 1981 and, more importantly, the inadequate collection efficiencies found in 1981 and thereafter render such examination futile. In the case of snow precipitation,

the raw snowcore data provided often did not contain sufficient information to accurately estimate deposition. In view of this, the evaluation of the impacts of projected emissions on precipitation is not at all warranted.

#### 6.7 RECOMMENDATIONS

Monitoring of precipitation chemistry and wet deposition in the AOSERP study area is warranted, in view of the current and proposed level of industrial activity in the region. The potential for industrial emissions to cause detrimental environmental effects needs no elaboration here, and monitoring activities such as those in the AOSERP network are essential. There is no doubt that continued operation of the AOSERP network is essential if the impacts of current and future industrial activities in the region are to be monitored and assessed.

The network objectives should be clearly and formally restated in general and specific terms. The formulation of these objectives is the prerogative and responsibility of Alberta Environment. It is assumed that these objectives will include (but not necessarily be limited to) the requirement for the network to sample wet precipitation in the region with emphasis on:

1. Monitoring the effects of current industrial point sources in order to resolve spatial and temporal patterns in precipitation chemistry and wet deposition.
2. Establishing baseline levels of precipitation quality in areas where industrial activity is planned.
3. Acquiring data of internationally acceptable quality and reliability.

The presumption of these objectives, together with the assessment and data analysis provided in this report, form the bases for the recommendations presented below. The recommendations for improving the network will build on the more recent (1984) procedures and will address the following areas:

1. Network objectives,
2. Documentation,

3. Siting of stations,
4. Instrumentation,
5. Field operations,
6. Laboratory procedures,
7. Quality assurance and quality control, and
8. Data capture, validation, retrieval, and reporting.

#### 6.7.1 Network Objectives

The network objectives must be clearly restated and documented. The development of the objectives should include the consideration of other environmental monitoring activities in the area, the limitations imposed by not maintaining an all-year sampling program, and available resources.

#### 6.7.2 Documentation

A comprehensive network documentation package should be developed to specify protocols for all network operations. The protocols need to be uniform and universally applied to ensure consistent, reliable, and uniform data. The documentation should include the following:

1. Siting and site documentation,
2. Instrumentation specification,
3. Field operations and protocols,
4. Laboratory protocols,
5. Sample handling and processing
6. A comprehensive quality assurance plan, and
7. Data capture, validation, retrieval, and reporting.

#### 6.7.3 Siting of Stations

Only those sites meeting acceptable criteria should be retained in the network. A site documentation package such as that presented in Section 8.3 could be utilized as a basis for retention and upgrading, or discontinuation or relocation of sites. The site documentation package should be complete and should be kept up-to-date.



#### 6.7.4 Instrumentation

In the case of rainfall sampling, the currently used manual system with daytime only collection will be subject to inconsistent and uncertain data quality. It is recommended that automated solar power/battery operated samplers such as the MIC or Aerochemetrics samplers be acquired and deployed in the network. Sites at which mains power is available or can be installed easily and inexpensively should use that power source.

#### 6.7.5 Field and Laboratory Operations

The strict adherence to the stipulated laboratory and field protocols is one of the vital components for ensuring good quality data.

Routine QA/QC protocols need to be developed for assessing precision of measurement. The results of these procedures should be analysed frequently and reported.

The laboratory protocols implemented in 1984 were quite adequate and should be continued. However, there should be regular participation and evaluation of interlaboratory comparison studies. Participation in these studies should be mandatory, and results should be used to qualify laboratories for analysis of AOSERP network samples. Laboratory procedures should be clearly documented and should include QA/QC test protocols. Results of the QA/QC should be reported routinely to network management.

#### 6.7.6 Quality Assurance and Quality Control

A quality assurance plan should be developed to address all aspects of network operation, including the level of documentation, systematic instrumentation checks, sample handling procedure checks, laboratory QA/QC requirements, interlaboratory comparison, reporting requirements, and the number and type of QA samples to be generated by network staff. In addition, provision should be made for external audits of network operations to verify correct implementation procedures. This audit should include a report to the network management on deficiencies found and recommendations for rectifying these deficiencies.

#### 6.7.7 Data Capture, Validation, Retrieval, and Reporting

The existing method of storing data is unacceptable and should be immediately abandoned. In the short term, data storage should take place in a fixed format file identical or similar to the format provided in this study. It is recommended that a database management system (DBMS) of the relational type be used as the major tool in a software package that will allow the capture, storage, retrieval, validation, reporting, and statistical analysis of AOSERP precipitation data. It is essential that the DBMS selected and the software package, together with the network field and laboratory operations, allow the data capture process to take place in a timely and efficient manner. It should be noted that a similar application to precipitation data in the CAPMoN network utilizes the Model 204 DBMS and that DBMS is compatible with existing hardware accessible to RMD. The cost of acquisition of Model 204 DBMS for the exclusive application to AOSERP precipitation data is prohibitive and, since that DBMS is not currently available on computer facilities readily accessible to RMD, the use of Model 204 is not feasible. It is recommended that a microcomputer-based software package that incorporates a DBMS be developed for manipulation of AOSERP precipitation data.

7. REFERENCES CITED

- Bardswick, W.S. 1983. Acidic precipitation in Ontario study. Technical and operating manual, APIOS deposition monitoring program. Ontario Ministry of the Environment, Air Resources Branch. n.p.
- Barrie, L.A., V. Nespliak, and J. Arnold. 1978. Chemistry of rain in the Athabasca oil sands region: Summer 1977. Downsview: Atmospheric Environment Service. Internal Report ARQT 3-78. 17 pp.
- Barrie, L.A. and J. Kovalick. 1980. A wintertime investigation of the deposition of pollutants around an isolated power plant in northern Alberta. Prep. for the Alberta Oil Sands Environmental Research Program by Atmospheric Environment Service. AOSERP Report 90. 115 pp.
- Barrie, L.A. and R.J. Vet. 1984. The concentration and deposition of acidity, major ions and trace metals in the snowpack of the eastern Canadian shield during the winter of 1980-1981. Atmospheric Environment 18:1459-1469.
- Blower, L. 1984a. Precipitation chemistry procedures manual. Athabasca Oil Sands Area. Prep. for Research Management Division, Alberta Environment. (Unpublished internal report, project RMD81-54). 20 pp.
- Blower, L. 1984b. Preliminary statistical analysis of the 1983 summer precipitation collected in the AOSERP area of northeastern Alberta. Prep. for Research Management Division, Alberta Environment. (Unpublished internal report, project RMD81-54). 39 pp.
- Chemex Labs, Alberta (1984) Ltd. 1984. Chemical analysis of summer precipitation in the oil sands area. Prep. for Research Management Division, Alberta Environment. (Unpublished internal report). 96 pp.
- Colley, D.G. and R.W. Poon. 1982. Alberta sulphur dioxide emissions forecast 1980-2000. Prep. for Research Management Division, Alberta Environment, by Western Research, Division of Bow Valley Resource Services Ltd. RMD Report 82/16. 101 pp.
- Colley, D.G., R.W. Poon, M.J. Zelensky, and L. Zanzotto. 1983. Alberta oxides of nitrogen emissions forecast 1980 to 2000. Prep. for Research Management Division, Alberta Environment, by Western Research, Division of Bow Valley Resource Services Ltd. Edmonton: (Alberta) Research Management Division. RMD Report 83/26. 101 pp.

- Concord Scientific Corporation. 1981. Detailed analysis of the Pennsylvania State University intercomparison of precipitation collectors data. Prep. for Atmospheric Environment Service. CSC Report 52-80. Downsview, Ontario. 70 pp.
- Concord Scientific Corporation. 1982. The Dorset intercomparison of precipitation and air sampling methodologies. Prep. for Ontario Ministry of the Environment, Air Resources Branch. CSC Report 110.J181-1. Downsview, Ontario. 104 pp.
- Concord Scientific Corporation. 1983a. A performance and systems audit of the acidic precipitation in Ontario study (APIOS) monitoring network. Prep. for Ontario Ministry of the Environment, Air Resources Branch. CSC Report 110.J131-1. Downsview, Ontario. 101 pp.
- Concord Scientific Corporation. 1983b. The Canadian air and precipitation monitoring network (CAPMoN) quality assurance plan for precipitation monitoring systems. Prep. for Atmospheric Environment Service, Air Quality and Inter-Environmental Research Branch. CSC Report 110.J194.3.1. Downsview, Ontario. n.p.
- Concord Scientific Corporation. 1983c. Determination of dry deposition rates to a snow surface. Prep. for Atmospheric Environment Service, Air Quality and Inter-Environmental Research Branch. CSC Report 110.J245. Downsview, Ontario.
- Concord Scientific Corporation. 1984a. The phase I report of the audit of the acidic precipitation in Ontario study monitoring network. Prep. for Ontario Ministry of the Environment, Air Resources Branch. CSC Report 110.J348.2. Downsview, Ontario. Report CSC.110.J348.2. n.p.
- Concord Scientific Corporation. 1984b. The phase II report of the audit of the acidic precipitation in Ontario study monitoring network. Prep. for Ontario Ministry of the Environment, Air Resources Branch. CSC Report 110.J348.3. Downsview, Ontario. Report CSC.110.J348.3. n.p.
- Concord Scientific Corporation. 1984c. Acidic precipitation in Ontario study (APIOS) quality assurance manual. Prep. for Ontario Ministry of the Environment, Air Resources Branch. CSC Report 110.J461.1. Downsview, Ontario. n.p.
- Easter, R.C. 1984. The OSCAR experiment. In: Deposition Both Wet and Dry, ed. B.B. Hicks. Stoneham, MA: Ann Arbor Science Press. Acid Precipitation Series 4:97-120.
- Environment Canada. 1979. Analytical methods manual. Inland Waters Directorate Water Quality Branch, Ottawa, Canada. n.p.

- Fanaki, F., Compiler. 1978. Meteorology and air quality winter field study in the AOSERP study area, March 1976. Prep. for Alberta Oil Sands Environmental Research Program by Fisheries and Environment Canada, Atmospheric Environment Service. AOSERP Report 27. 249 pp.
- Galloway, J.N. and G.E. Likens. 1976. Calibration of collection procedures for determination of precipitation chemistry. *Water, Air and Soil Pollution* 6:241-258.
- Galloway, J.N. and G.E. Likens. 1978. The collection of precipitation for chemical analysis. *Tellus* 30:71-82.
- Gourlay, P. and L. Blower. 1983. Summary report on the winter snow chemistry project RMD82-36. Prep. for Research Management Division, Alberta Environment. (Unpublished internal report). 13 pp.
- Johannessen, M. and A. Henrikson. 1978. Chemistry of snowmelt water. Changes in concentration during melting. *Water Resources Recovery* 14:615-619.
- Johnson, R.R. 1976. Elementary statistics. North Scituate, Massachusetts: Duxbury Press. 550 pp.
- Klein, W.H. 1957. Principal tracks and mean frequencies of cyclones and anticyclones in the northern hemisphere. Research Paper No. 40. Weather Bureau. U.S. Department of Commerce, Washington, D.C. 60 pp.
- Murray, W.A. 1981. The 1981 snowpack survey in the AOSERP study area December 1981. Prep. for Research Management Division, Alberta Environment. AOSERP Report 125. 137 pp.
- Nespliak, V.E. 1977. Precipitation chemistry procedures manual. Prep. for Atmospheric Environment Service, Western Region, Edmonton and Alberta Oil Sands Environmental Research Program, Edmonton. 4 pp.
- Olson, R. 1982. Precipitation chemistry procedures manual. Athabasca Oil Sands Area. Prep. for Research Management Division, Alberta Environment. (Unpublished internal report RMD81-54). 11 pp.
- Olson, R., B. Magill, B. Thomson, and H. Bertram. 1982. Analysis of event rain samples in northeastern Alberta. Prep. for Research Management Division, Alberta Environment. (Unpublished internal report). 18 pp.

- Olson, R., B. Thomson, H. Bertram, and R. Peters. 1982 . Athabasca oil sands precipitation chemistry studies: 1976-1979 and 1981. Prep. for Research Management Division, Alberta Environment, by Research Management Division, Alberta Environment and Alberta Environmental Centre. AOSERP Report No. 129. 59 pp.
- Peters, R. 1981. Precipitation chemistry procedures manual. Prep. for Research Management Division, Alberta Environment. (Unpublished internal report RMD81-54). 59 pp.
- Peters, R.R., H.S. Sandhu, and W.D. Hume. 1981. An analysis of precipitation chemistry in the oil sands area of northern Alberta. Proceedings Air Pollution Sessions, CMOS, 19th Annual Congress, Saskatoon, Saskatchewan. May 27-29. pp. 147-157.
- Statistics Canada. 1982. 1981 census of Canada. Census subdivisions of 5,000 population and over. Population, occupied private dwellings, private households, census families in private households. Selected characteristics. Ottawa: Minister of Supply and Services. Catalogue 95-904 (Volume 3 - Profile series A). 224 pp.
- US EPA. 1976. Quality assurance handbook for air pollution measurement systems. Volume I - principles. US Environmental Protection Agency Report EPA-600/9-76-005. n.p. (Available from US EPA, ORD Publications).
- Whittaker, L.M. and L.H. Horn. 1982. Atlas of northern hemisphere extratropical cyclone activity 1958-1977. Madison, Wisconsin: Department of Meteorology, University of Wisconsin. 65 pp.
- Yurko, D. 1984. Addendum to the preliminary statistical analysis of the 1983 summer precipitation collected in the AOSERP area of northeastern Alberta. Research Management Division, Alberta Environment. (Unpublished internal report RMD81-51). 41 pp.

8.        APPENDICIES

8.1       RAW DATA FILE REFERENCE

      The following is a reference list of the twenty-nine files on which the data were encoded in file format.

Table 56. Designation of file numbers for raw AOSERP deposition data.

Year	Sample Type		
	Snow	Rain	Dryfall
1976	13, 14	25, 26	
1977	13	25, 26	
1978	13, 15, 16	25, 26	
1979	13	25, 26	
1980	13		
1981	17	2, 7, 21, 23	
1982	13, 18	2, 21, 24	
1983	19	1, 8, 9, 10, 11, 22	5
1984	4, 6, 20, 27	3, 12, 28, 29	



8.2 AOSERP SITE DIAGRAMS

The following are diagrams of the AOSERP monitoring sites prepared by Alberta Environment personnel.

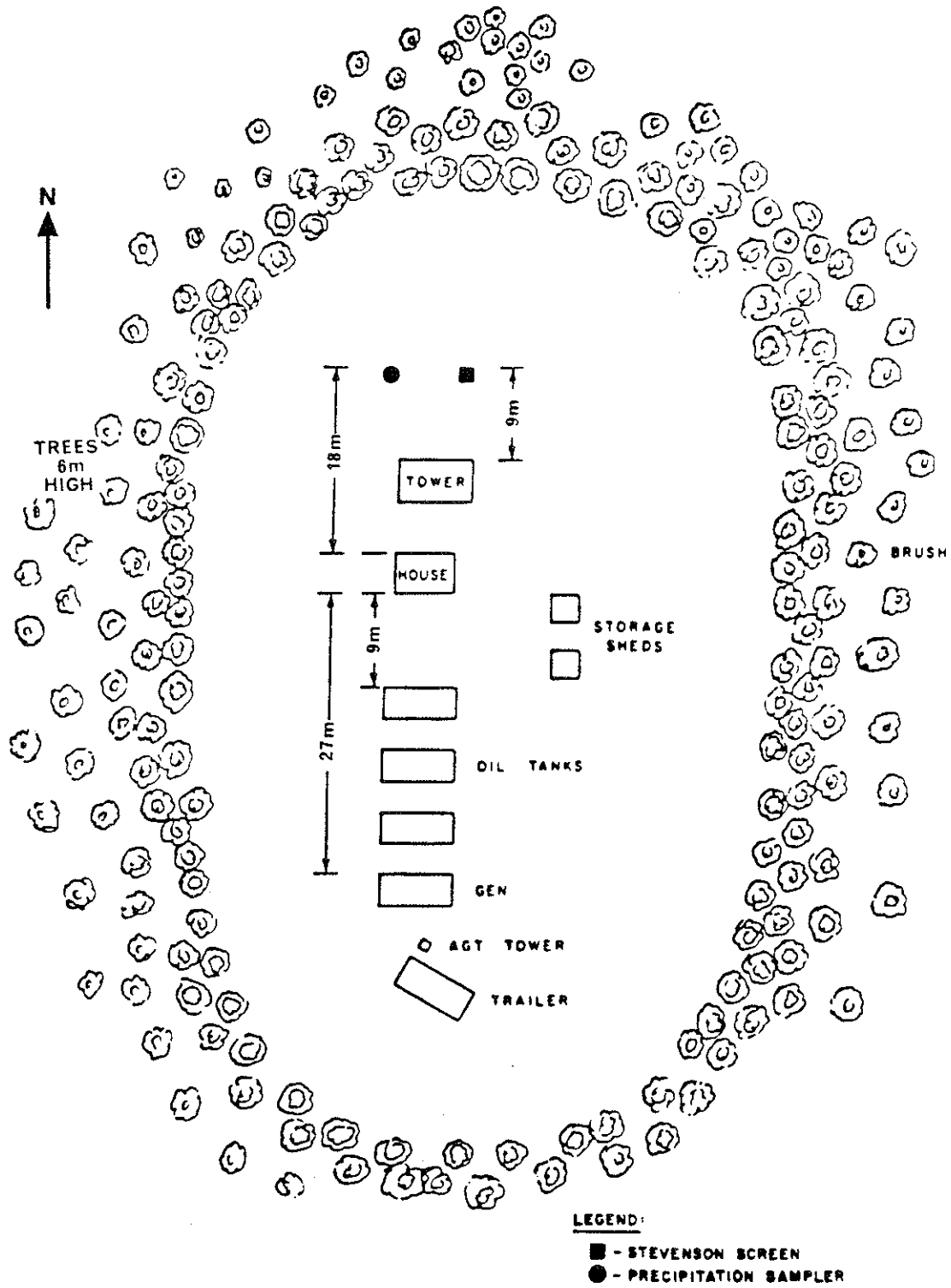

Figure 47. Birch Mountain lookout.

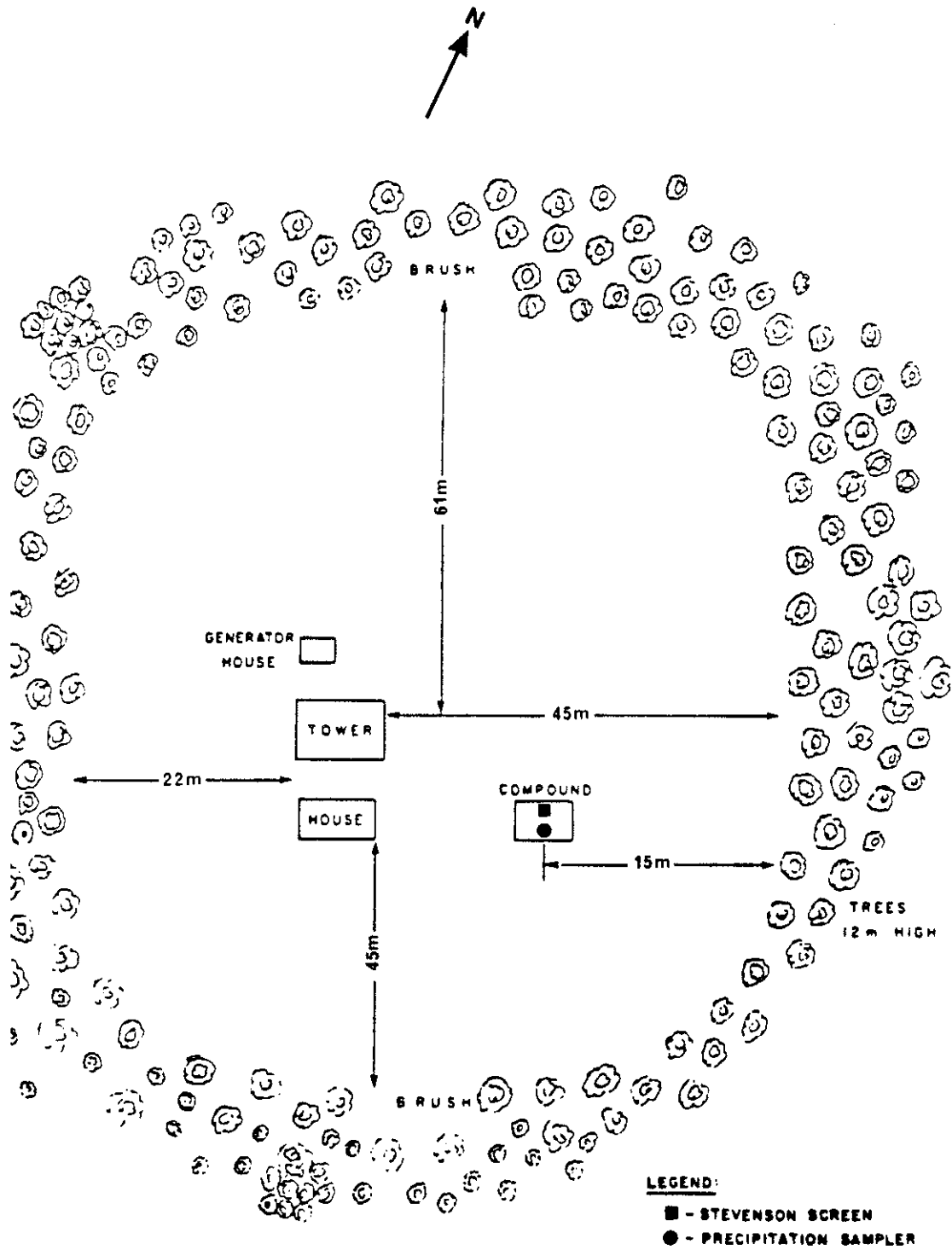

Figure 48. Bitumount lookout.

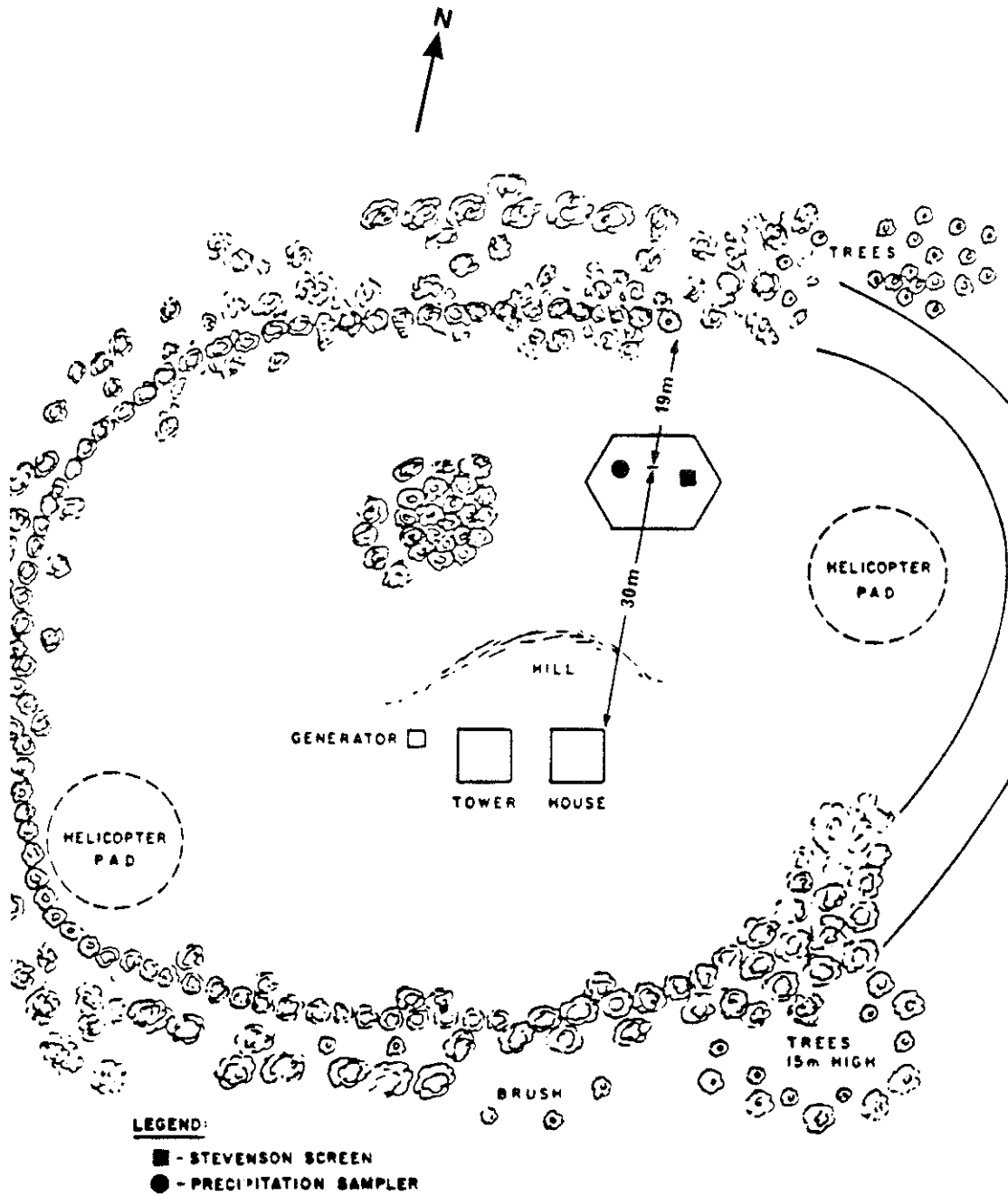

Figure 49. Buckton lookout.

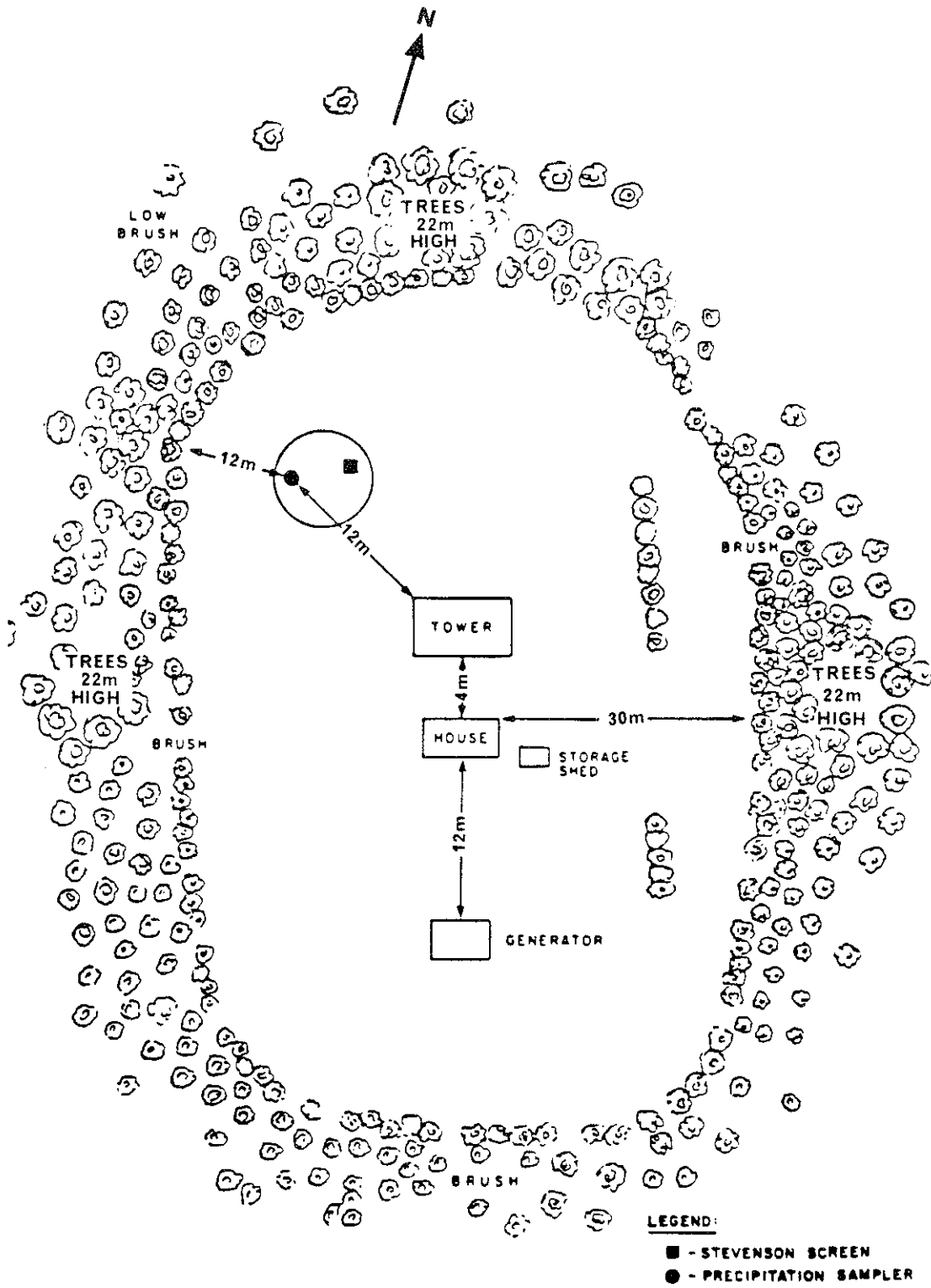

Figure 50. Ells lookout.

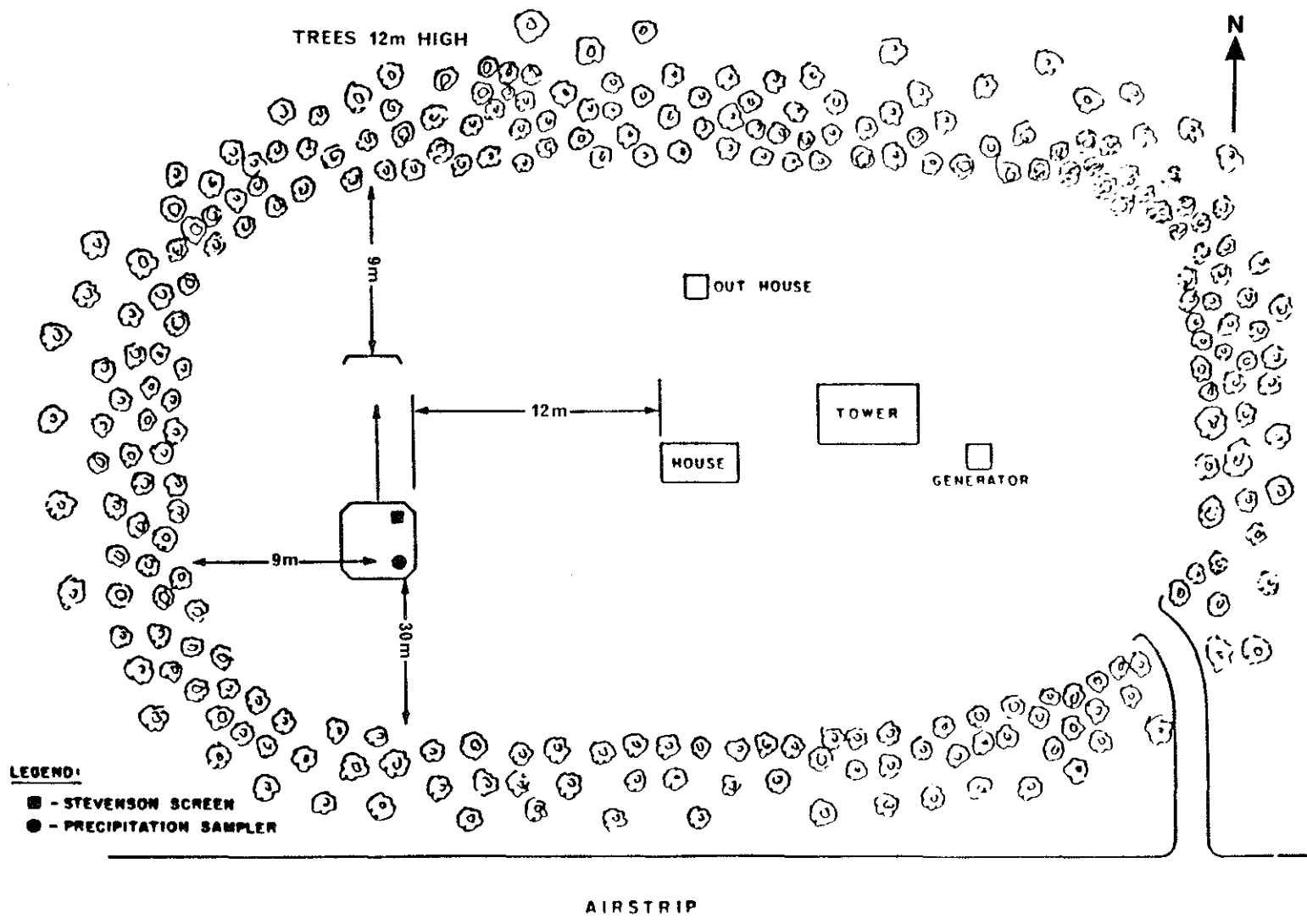

Figure 51. Gordon Lake lookout.

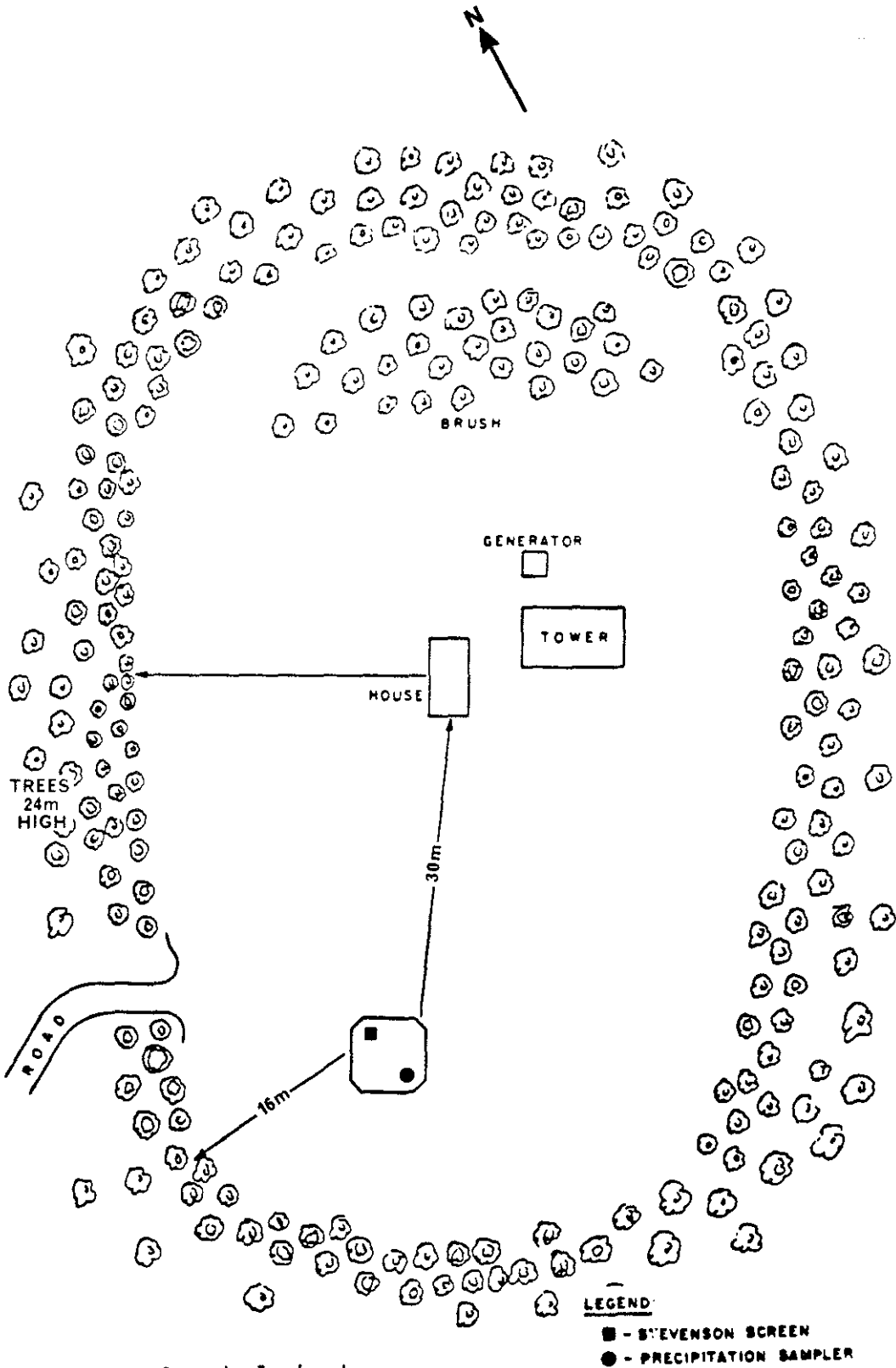

Figure 52. Grande lookout.

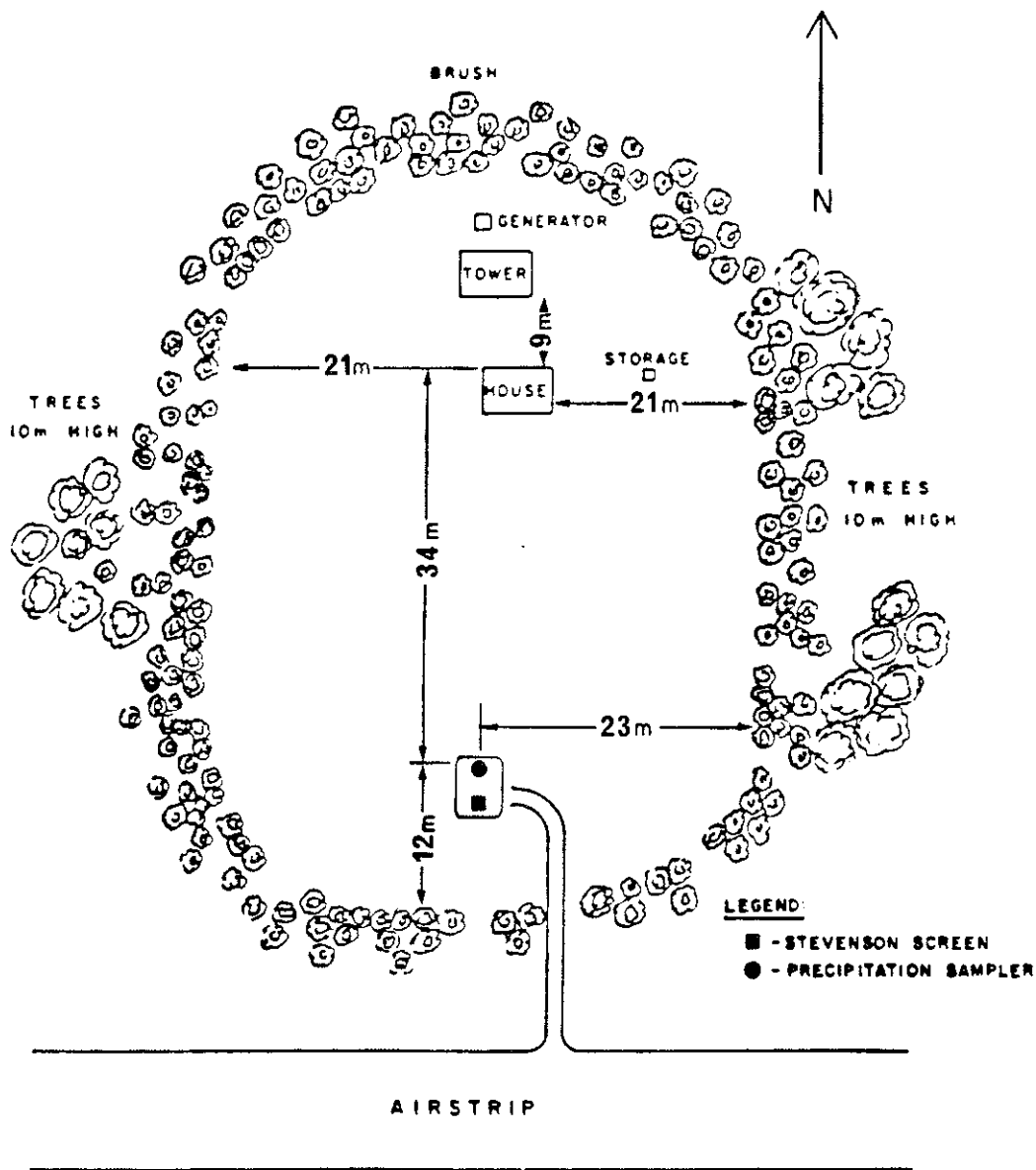

Figure 53. Johnson Lake lookout.



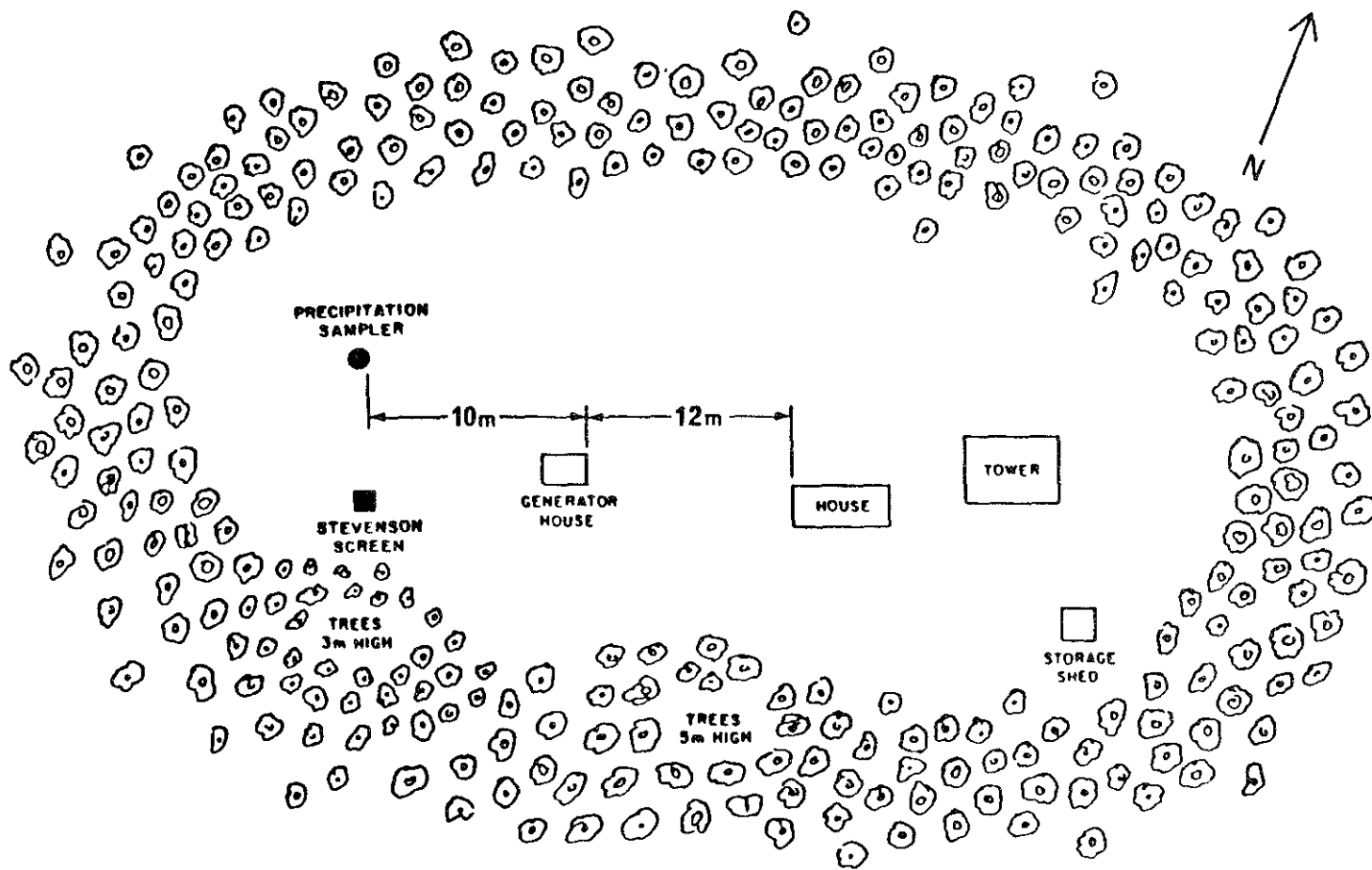

Figure 54. Keane Creek Lookout.

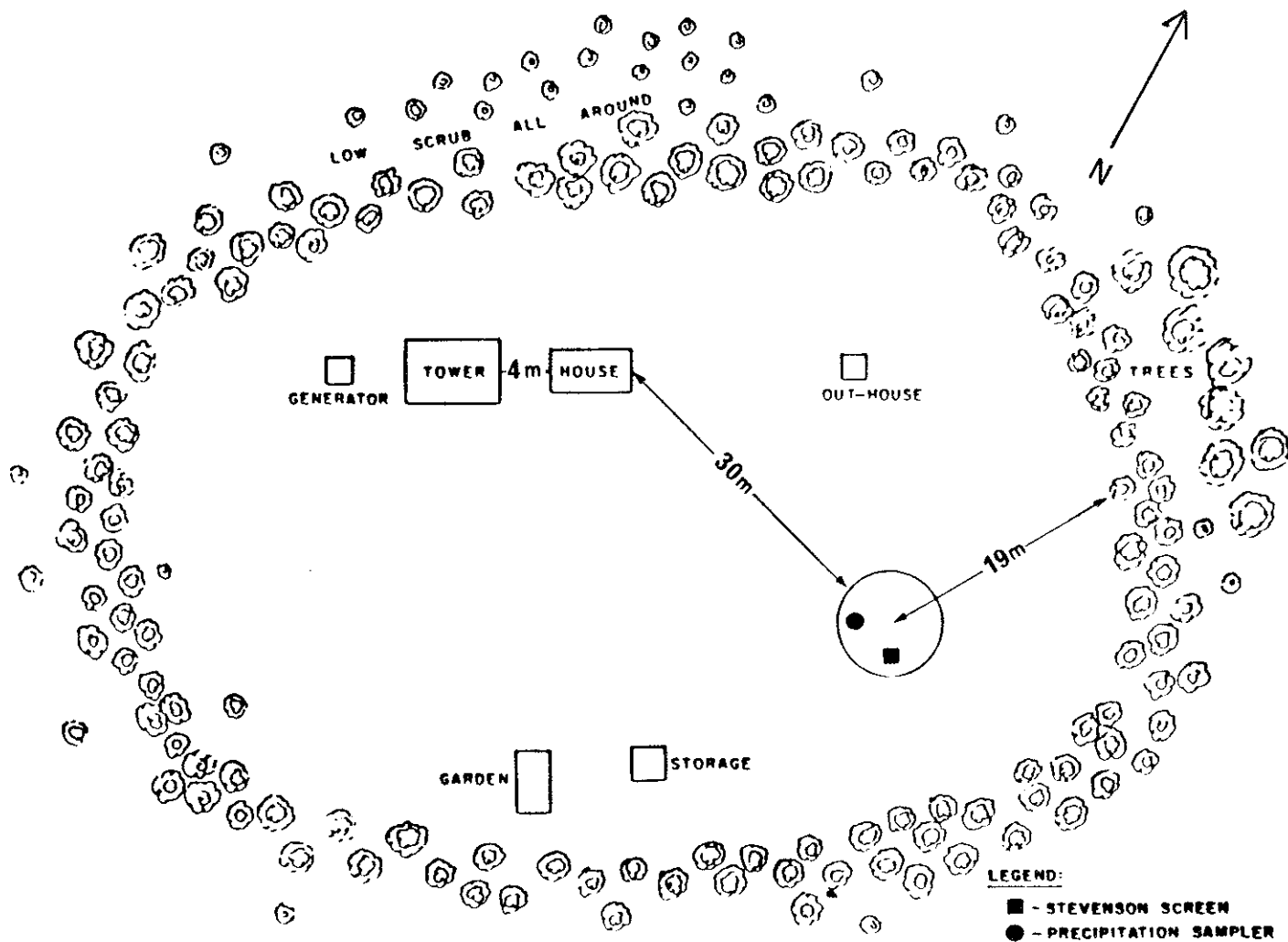

Figure 55. Legend lookout.

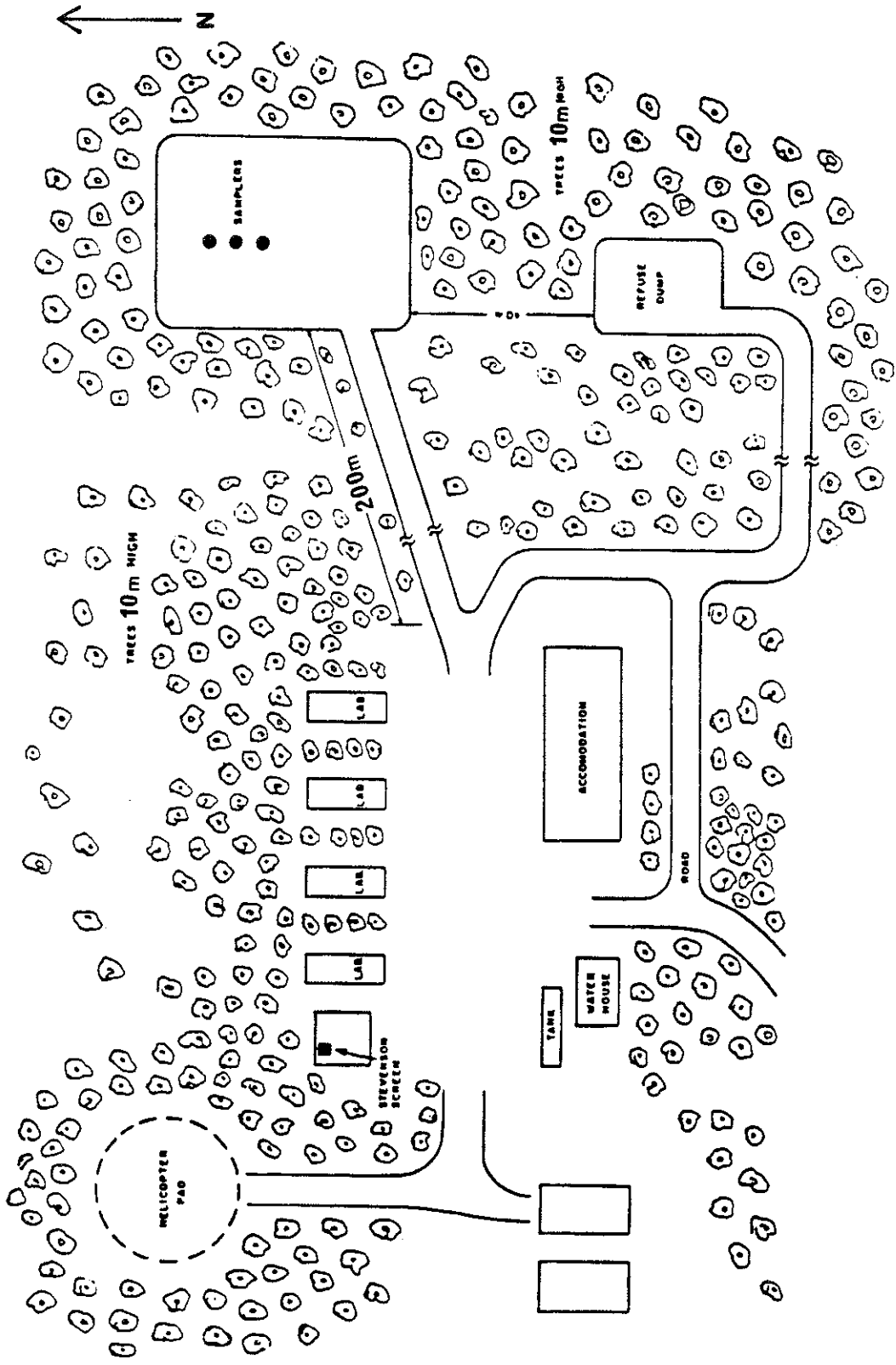

Figure 56. Mildred Lake Research Facility.

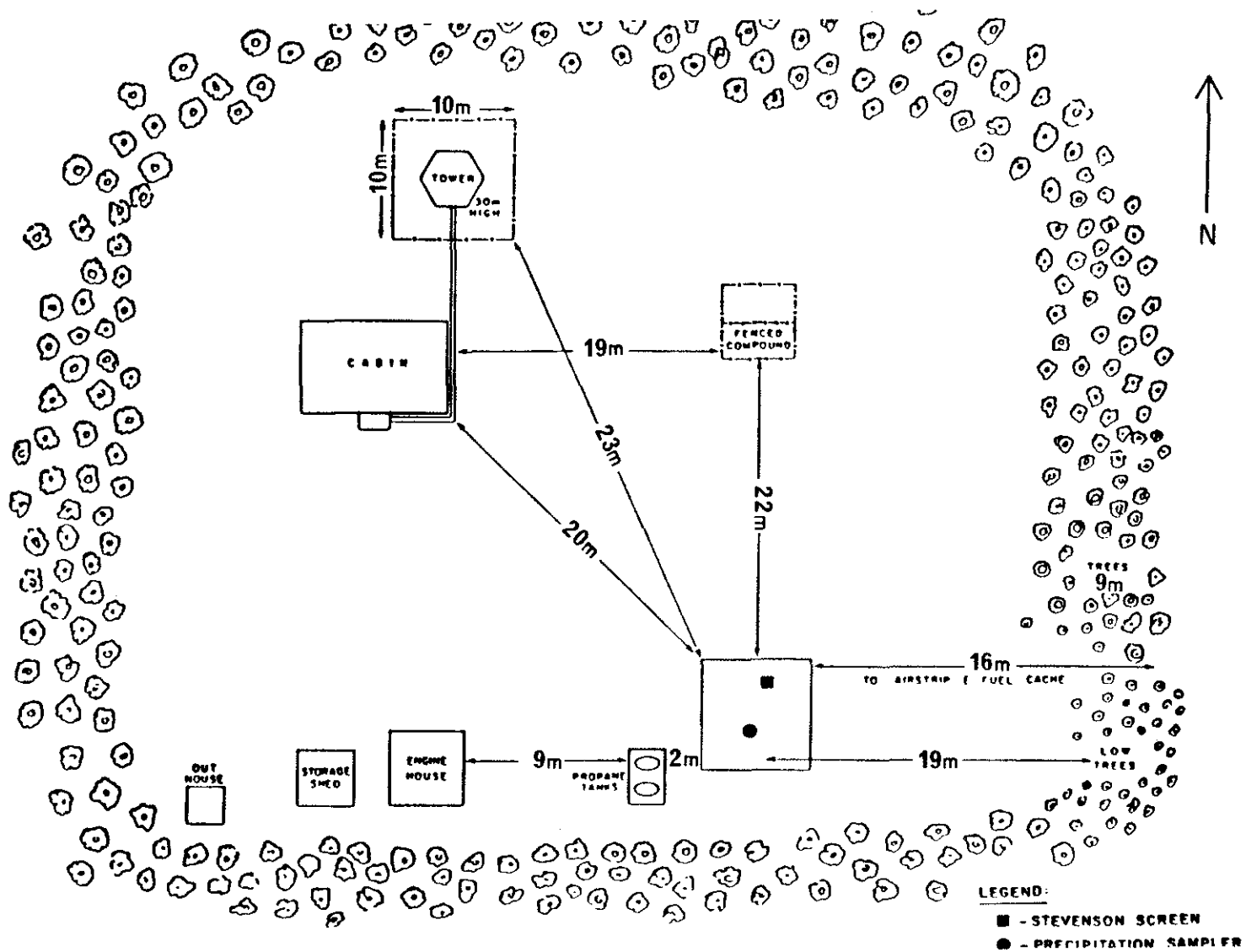

Figure 57. Muskeg Mountain lookout.

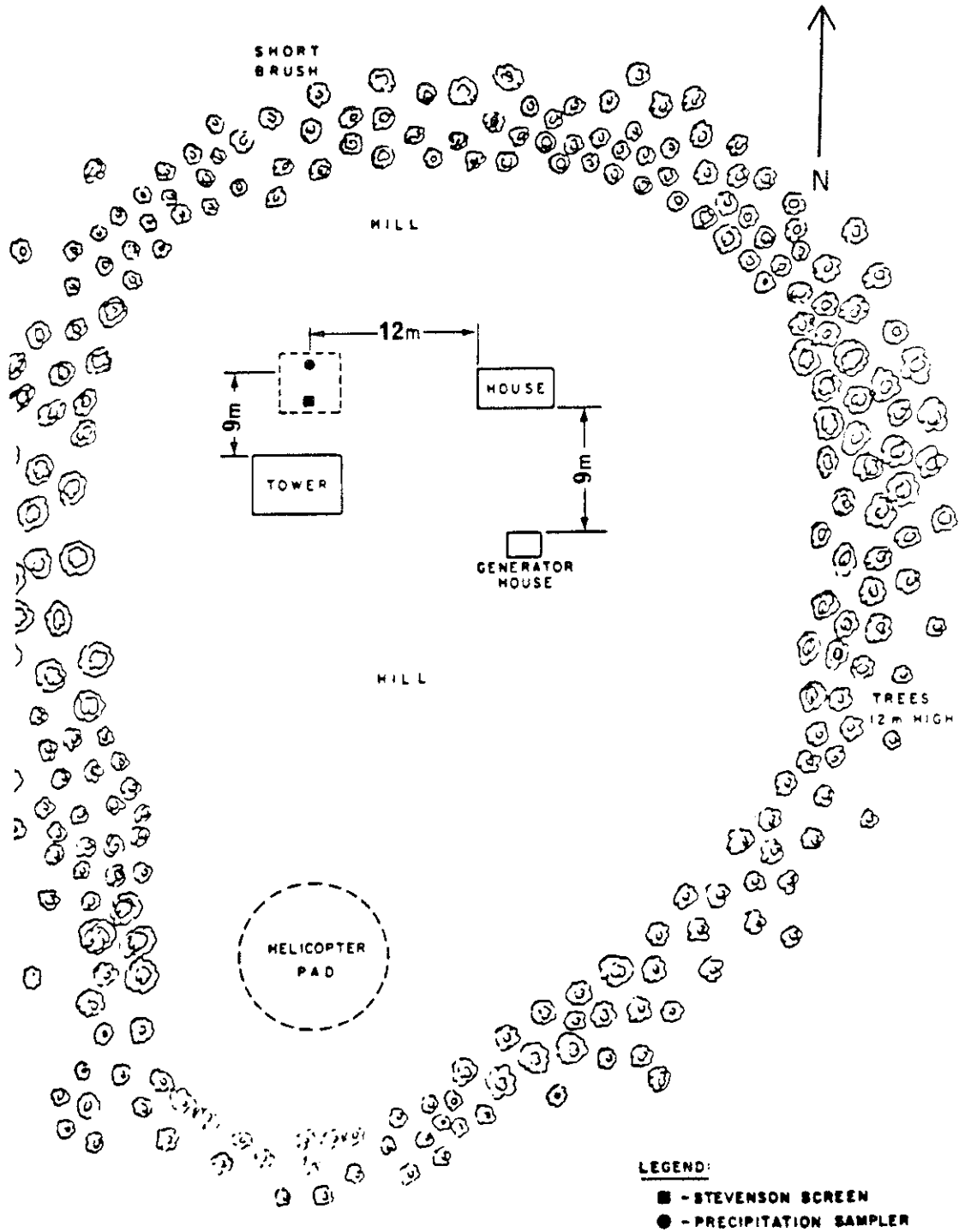

Figure 58. Richardson lookout.

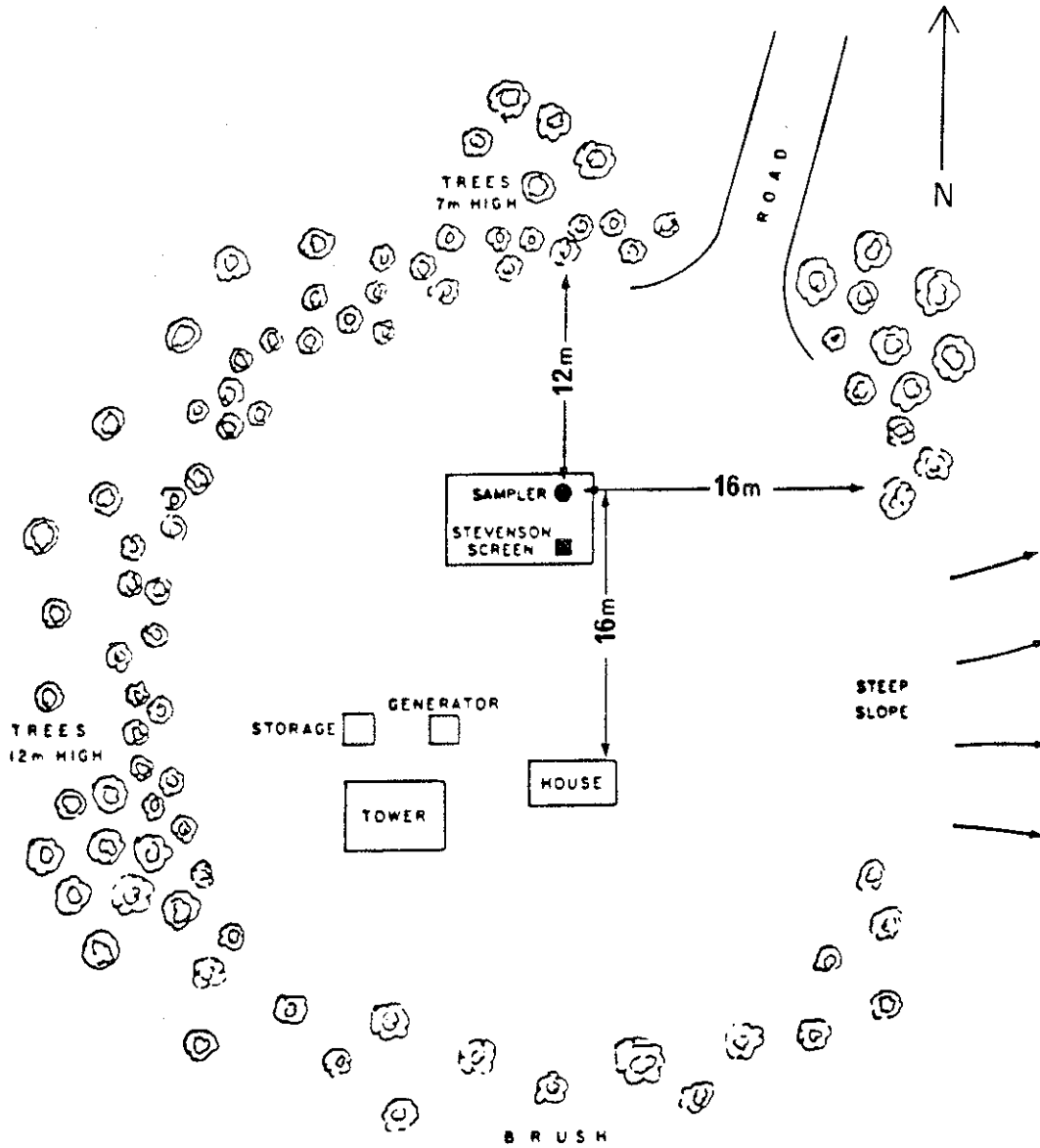

Figure 59. Stony Mountain lookout.

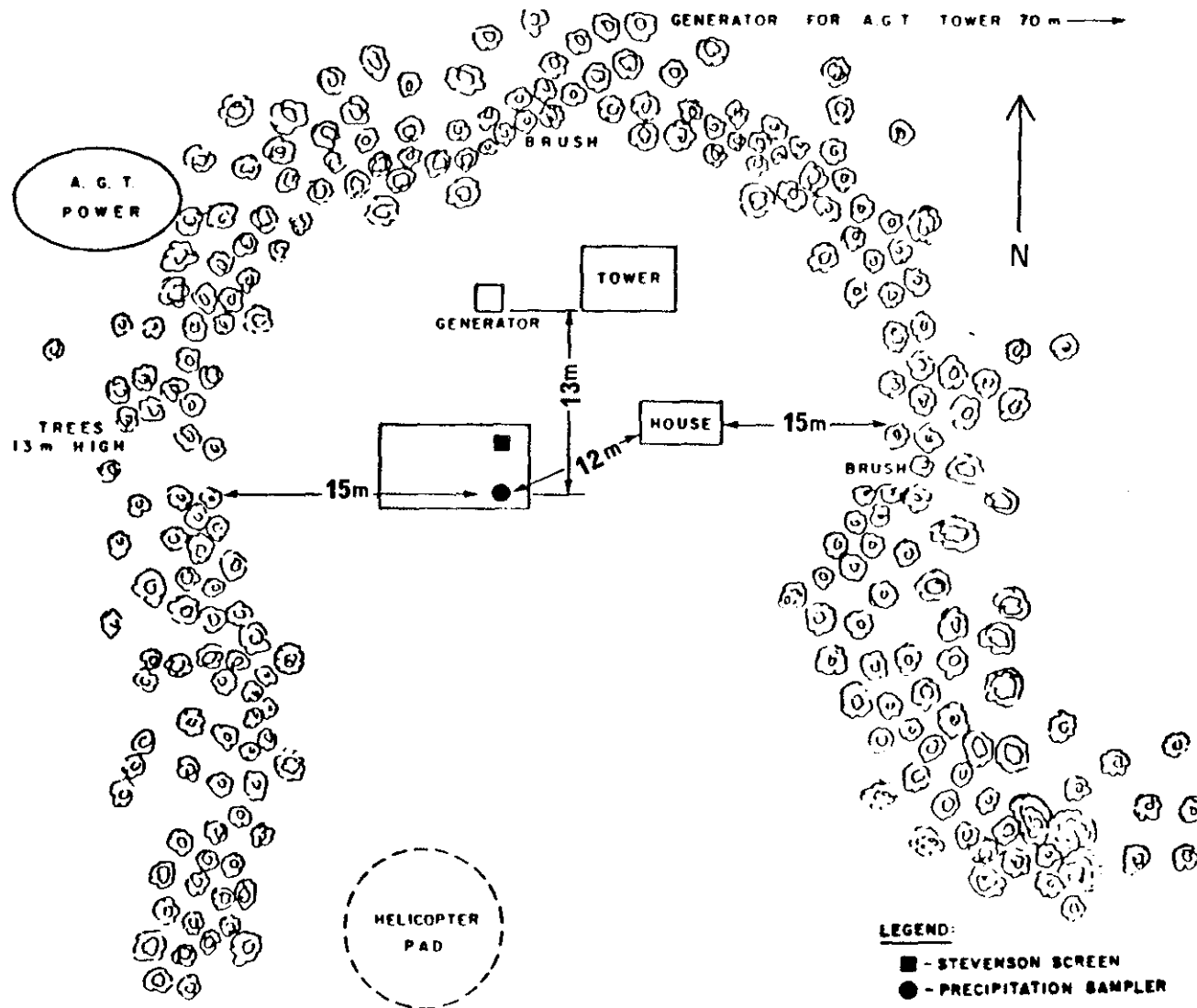

Figure 60. Thickwood Hills lookout.

8.3 PROPOSED SITE DOCUMENTATION PACKAGE FOR AOSERP SITES

The following is a suggested site documentation package for AOSERP sites.





DOCUMENTATION ON AOSERP MONITORING SITES

Site Name \_\_\_\_\_  
 Page Number 2  
 Revision Date \_\_\_\_\_  
 Revision Number 0

## A. GENERAL INFORMATION

1. SITE NAME AND ABBREVIATION \_\_\_\_\_
2. SITE IDENTIFIER \_\_\_\_\_
3. SITE ADDRESS  
 \_\_\_\_\_  
 Number, Street, RR#  
 \_\_\_\_\_  
 Town, Province, Postal Code
4. LATITUDE AND LONGITUDE  
 \_\_\_\_\_ N \_\_\_\_\_ W  
 Latitude \_\_\_\_\_ Longitude \_\_\_\_\_
5. UTM CO-ORDINATES  
 \_\_\_\_\_  
 Northing \_\_\_\_\_ Easting \_\_\_\_\_
6. ELEVATION  
 \_\_\_\_\_  
 (m above MSL)
7. ON-SITE MEASUREMENTS  
 \_\_\_\_\_  
 Type \_\_\_\_\_  
 \_\_\_\_\_  
 Type \_\_\_\_\_  
 \_\_\_\_\_  
 Type \_\_\_\_\_  
 \_\_\_\_\_  
 Type \_\_\_\_\_
8. DATES  
 \_\_\_\_\_  
 Station Start Date \_\_\_\_\_
9. OPERATORS  
 - PRIMARY/SECONDARY  
 \_\_\_\_\_ Name \_\_\_\_\_ Name \_\_\_\_\_  
 \_\_\_\_\_ Address \_\_\_\_\_ Address \_\_\_\_\_  
 \_\_\_\_\_ Address \_\_\_\_\_ Address \_\_\_\_\_  
 \_\_\_\_\_ Telephone \_\_\_\_\_ Telephone \_\_\_\_\_
10. CLOSEST SURFACE WEATHER STATION  
 \_\_\_\_\_  
 Name \_\_\_\_\_ Distance(km)/Direction \_\_\_\_\_
11. CLOSEST CLIMATE SITE  
 \_\_\_\_\_  
 Name \_\_\_\_\_ Distance(km)/Direction \_\_\_\_\_

DOCUMENTATION ON AOSERP MONITORING SITES

Site Name \_\_\_\_\_  
 Page Number 3  
 Revision Date \_\_\_\_\_  
 Revision Number 0

**B. SITE DETAILS**

**1. PROPERTY TYPE**

Park, Gov't. Facil., Private Property

**2. SITE DESCRIPTION**

Forest Clearing, Open Area, Other

**3. SITE TOPOGRAPHY**

Flat, Hill, Slope

**4. GROUND SLOPE ON SITE**

Upslope/Downslope/Flat Slope(deg.) Direction

**5. SITE SPECIFIC GROUND COVER**

\_\_\_\_\_

**6. WINDBREAKS OR OBSTRUCTIONS WITHIN 100 m OF SAMPLER**

Type	Height(m)	Dist.(m)	Dir.
_____	_____	_____	_____
_____	_____	_____	_____

**7. SURFACE CHARACTERISTICS BY SECTOR**

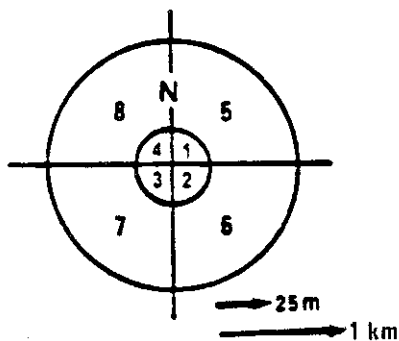

1.	Land Use	%	Ground Cover	%
2.	_____	_____	_____	_____
3.	_____	_____	_____	_____
4.	_____	_____	_____	_____
5.	_____	_____	_____	_____
6.	_____	_____	_____	_____
7.	_____	_____	_____	_____
8.	_____	_____	_____	_____

**8. SURROUNDING AREA CHARACTERISTICS**

General Land Use

General Topography

**9. ON-SITE BUILDINGS**

Type \_\_\_\_\_ Heating \_\_\_\_\_

Type \_\_\_\_\_ Heating \_\_\_\_\_

DOCUMENTATION ON AOSERP MONITORING SITES

Site Name \_\_\_\_\_  
 Page Number 4  
 Revision Date \_\_\_\_\_  
 Revision Number 0

## B. SITE DETAILS (CONTINUED)

## 10. CURRENT LAND OWNER

Name \_\_\_\_\_

Address \_\_\_\_\_  
 \_\_\_\_\_

Telephone \_\_\_\_\_

11. CURRENT LAND CONTACT  
(if different from above)

Name/Position \_\_\_\_\_

Address \_\_\_\_\_  
 \_\_\_\_\_

Telephone \_\_\_\_\_

## 12. SAMPLE HANDLING AREA

Description \_\_\_\_\_  
 \_\_\_\_\_Address \_\_\_\_\_  
 \_\_\_\_\_

Telephone \_\_\_\_\_

Distance from Sampling Site \_\_\_\_\_  
 \_\_\_\_\_13. WHERE DO SNOW AND DUST  
DRIFT AND ACCUMULATE?

\_\_\_\_\_

\_\_\_\_\_

\_\_\_\_\_

## 14. METHOD OF ACCESS TO SITE

Summer \_\_\_\_\_ Winter \_\_\_\_\_

15. HOW CLOSELY DO VEHICLES  
NORMALLY APPROACH SAMPLER?

\_\_\_\_\_

DOCUMENTATION ON AOSERP MONITORING SITES

Site Name \_\_\_\_\_  
 Page Number 5  
 Revision Date \_\_\_\_\_  
 Revision Number 0

C. INSTRUMENT DETAILS

MEASUREMENT	INSTRUMENT TYPE/MAKE	MODEL	SERIAL NUMBER	DATE INSTALLED	COMMENTS

DOCUMENTATION ON AOSERP MONITORING SITES

Site Name \_\_\_\_\_  
 Page Number 6  
 Revision Date \_\_\_\_\_  
 Revision Number 0

D. SITE INFLUENCES

1. ON-SITE OBSTRUCTIONS

TYPE	DISTANCE(m)/DIRECTION FROM SAMPLER	HEIGHT OR SIZE (m)	COMMENTS
------	---------------------------------------	-----------------------	----------

2. ROADWAY INFLUENCES WITHIN 5 km

TYPE	NAME	SURFACE/ USAGE	DISTANCE(km)/ DIRECTION	SNOW/DUST CONTROL
------	------	-------------------	----------------------------	----------------------

DOCUMENTATION ON AOSERP MONITORING SITES

Site Name \_\_\_\_\_

Page Number 7

Revision Date \_\_\_\_\_

Revision Number 0

## D. SITE INFLUENCES (CONTINUED)

## 3. LOCAL AND AREA POLLUTION SOURCES

TYPE	NAME	DISTANCE(km)/ DIRECTION	CAPACITY OR PRODUCT	EMISSIONS TYPE/RATE
------	------	----------------------------	------------------------	------------------------

## 4. POPULATION CENTRES

NAME	DISTANCE(km)	DIRECTION	POPULATION
------	--------------	-----------	------------

DOCUMENTATION ON AOSERP MONITORING SITES

Site Name \_\_\_\_\_  
 Page Number 8  
 Revision Date \_\_\_\_\_  
 Revision Number 0

D. SITE INFLUENCES (CONTINUED)

5. OTHER TRANSPORTATION-RELATED INFLUENCES

TYPE	NAME	DISTANCE(km)/ DIRECTION	USAGE	COMMENTS
------	------	----------------------------	-------	----------

6. AGRICULTURAL ACTIVITY

TYPE	AMOUNT	DISTANCE/DIRECTION (km)	HERBICIDES/ PESTICIDES
------	--------	----------------------------	---------------------------



DOCUMENTATION ON AOSERP MONITORING SITES

Site Name \_\_\_\_\_

Page Number 9

Revision Date \_\_\_\_\_

Revision Number 0

D. SITE INFLUENCES (CONTINUED)

7. DEVIATIONS FROM SITING CRITERIA

---

DEVIATIONS	REASONS FOR ACCEPTANCE
------------	------------------------

---

---

8. SITE SELECTION CONSIDERATIONS

---

ADVANTAGES	DISADVANTAGES
------------	---------------

---

DOCUMENTATION ON AOSERP MONITORING SITES

Site Name \_\_\_\_\_  
Page Number 10  
Revision Date \_\_\_\_\_  
Revision Number 0

E. SAMPLING DETAILS

1. ROUTINE SAMPLING

TYPE OF SAMPLING	START DATE	SAMPLING FREQUENCY	TIME OF COLLECTION
------------------	------------	--------------------	--------------------

---

2. CURRENT SPECIAL STUDIES

Description \_\_\_\_\_  
\_\_\_\_\_  
\_\_\_\_\_  
\_\_\_\_\_  
\_\_\_\_\_  
\_\_\_\_\_  
\_\_\_\_\_  
\_\_\_\_\_  
\_\_\_\_\_  
\_\_\_\_\_

DOCUMENTATION ON AOSERP MONITORING SITES

Site Name \_\_\_\_\_  
Page Number 11  
Revision Date \_\_\_\_\_  
Revision Number 0

F. TOPOGRAPHIC MAP

1. MAP IDENTIFICATION

Series : \_\_\_\_\_  
Map : \_\_\_\_\_ Scale \_\_\_\_\_  
Edition: \_\_\_\_\_

2. MAP

DOCUMENTATION ON AOSERP MONITORING SITES



















Site Name \_\_\_\_\_  
Page Number 12  
Revision Date \_\_\_\_\_  
Revision Number 0

G. SITE DIAGRAM

- 1. NOTABLE ITEMS: North, Prevailing Wind Direction During Precipitation, Windbreaks, Roads, Parking Lots, Buildings, Ground Cover, Trees/Hedges/Fences, Obstructions (poles, towers), Water, Topography, Crops/Gardens, Paths, Hydro Services, Instrument Locations, Marshes, Railroad Tracks, Contamination Sources, Legend.
- 2. DIAGRAM

3. SCALE

LEGEND OF SYMBOLS FOR USE IN SITE DRAWINGS

	Aerial Cable		North
	Brush		Poles
	Building		Prevailing Wind Direction
	Coniferous Trees		Primary Sampler
	Deciduous Trees		Railroad Tracks
	Fence		Roads
H-	Height		Sloping Ground
	Helicopter Pad		Stevenson Screen
	Low Vol		Storage Gauge
	Nipher Gauge		Tower

DOCUMENTATION ON AOSERP MONITORING SITES

Site Name \_\_\_\_\_  
Page Number 14  
Revision Date \_\_\_\_\_  
Revision Number 0

H. SITE PHOTOGRAPHS

1. PERSPECTIVE: (LOOKING TOWARDS DIRECTION INDICATED)

DOCUMENTATION ON AOSERP MONITORING SITES

Site Name \_\_\_\_\_  
Page Number 15  
Revision Date \_\_\_\_\_  
Revision Number 0

H. SITE PHOTOGRAPHS (CONTINUED)

2. OTHER PHOTOGRAPHS (AERIAL) OR MAPS (DETAILED)

DOCUMENTATION ON AOSERP MONITORING SITES

Site Name \_\_\_\_\_  
Page Number 16  
Revision Date \_\_\_\_\_  
Revision Number 0

**I. INSTALLATION DETAILS**

**1. CURRENT ELECTRICAL SERVICE DESCRIPTION**

\_\_\_\_\_  
Service Size/type

\_\_\_\_\_  
Service Location with Respect to Sampler(s)

\_\_\_\_\_  
Type and Location of Breakers

\_\_\_\_\_  
Type and Location of Source

\_\_\_\_\_  
Source to Service Method (e.g., buried cable)



DOCUMENTATION ON AOSERP MONITORING SITES

Site Name \_\_\_\_\_

Page Number 17

Revision Date \_\_\_\_\_

Revision Number 0

## 1. INSTALLATION DETAILS (CONTINUED)

## 2. CHANGES TO ORIGINAL INSTALLATION

CHANGES	DATE	CARRIED OUT BY	REASON
---------	------	-------------------	--------

DOCUMENTATION ON AOSERP MONITORING SITES

Site Name \_\_\_\_\_

Page Number 18

Revision Date \_\_\_\_\_

Revision Number 0

## J. OPERATIONAL DETAILS

## 1. CURRENT OPERATOR - PRIMARY

Name \_\_\_\_\_

Position/Occupation \_\_\_\_\_

Address \_\_\_\_\_  
\_\_\_\_\_

Telephone (Bus./Res.) \_\_\_\_\_

Sampling Schedule \_\_\_\_\_

Remuneration \_\_\_\_\_

## 2. CURRENT OPERATOR - BACKUP

Name \_\_\_\_\_

Position/Occupation \_\_\_\_\_

Address \_\_\_\_\_  
\_\_\_\_\_

Telephone (Bus./Res.) \_\_\_\_\_

Sampling Schedule \_\_\_\_\_

Remuneration \_\_\_\_\_

DOCUMENTATION ON AOSERP MONITORING SITES

Site Name \_\_\_\_\_  
Page Number 19  
Revision Date \_\_\_\_\_  
Revision Number 0

J. OPERATIONAL DETAILS (CONTINUED)

3. DESCRIPTION AND SKETCH OF  
HOW TO REACH SITE

---

---

---

---

---

SKETCH

DOCUMENTATION ON AOSERP MONITORING SITES

Site Name \_\_\_\_\_  
Page Number 20  
Revision Date \_\_\_\_\_  
Revision Number 0

K. SITE HISTORY

1. PHYSICAL CHANGES TO SITE OR SURROUNDINGS

DATE	CHANGES
------	---------

DOCUMENTATION ON AOSERP MONITORING SITES

Site Name \_\_\_\_\_

Page Number 21

Revision Date \_\_\_\_\_

Revision Number 0

## K. SITE HISTORY (CONTINUED)

## 2. INSTRUMENTATION HISTORY

<u>INSTRUMENT TYPE/MAKE/MODEL</u>	<u>SERIAL NUMBER</u>	<u>DATE INSTALLED/ REMOVED</u>	<u>REASON FOR CHANGE</u>
---------------------------------------	--------------------------	------------------------------------	------------------------------

DOCUMENTATION ON AOSERP MONITORING SITES

Site Name \_\_\_\_\_

Page Number 22

Revision Date \_\_\_\_\_

Revision Number 0

## K. SITE HISTORY (CONTINUED)

## 3. INSTRUMENT DOWN TIME

INSTRUMENT TYPE/MAKE/MODEL	SERIAL NUMBER	DOWN TIME DATES FROM TO	REASON
-------------------------------	------------------	----------------------------	--------

DOCUMENTATION ON AOSERP MONITORING SITES

Site Name \_\_\_\_\_

Page Number 23

Revision Date \_\_\_\_\_

Revision Number 0

## K. SITE HISTORY (CONTINUED)

## 5. OPERATOR HISTORY

NAME/ADDRESS	PRIMARY/POSITION BACKUP	DATES START/END	HOW TO CONTACT	CONTRACTUAL DETAILS
--------------	----------------------------	--------------------	-------------------	------------------------

DOCUMENTATION ON AOSERP MONITORING SITES

Site Name \_\_\_\_\_  
 Page Number 24  
 Revision Date \_\_\_\_\_  
 Revision Number 0

K. SITE HISTORY (CONTINUED)

6. OPERATOR TRAINING OR UPGRADING

INDIVIDUAL TRAINED	POSITION (PRIMARY/BACKUP)	DATE TRAINED	TRAINED BY	TYPE OF TRAINING
--------------------	---------------------------	--------------	------------	------------------

7. SITE PROBLEMS (Power Failures, Vandalism, Other)

TYPE OF PROBLEM	DATE OF OCCURRENCE	DATE OF REPAIR
-----------------	--------------------	----------------



#### 8.4 SAMPLE HANDLING AND SAMPLE INTEGRITY

The following are some key steps in sample handling to ensure sample integrity:

1. Designing operator handling procedures to minimize potential sample contamination.
2. Ensuring chemical stability of samples by storing them at approximately 4°C and shipping them in coolers with ice packs.
3. Protecting samples during shipment by proper packing and sample inspection before shipment (e.g., checking that samples are heat-sealed properly and not leaking).
4. Ensuring that operating procedures are well documented, clearly written, concise, and properly executed.
5. Ensuring that all operators and technical staff have been properly trained and evaluated during sample pick-up visits.
6. Ensuring that all relevant sampling information is recorded properly on field data sheets.

## 8.5 SITE SELECTION CRITERIA - SNOW CHEMISTRY SURVEY

The recommended site selection criteria for snow chemistry surveys are described below.

### 1. Study Area and Study Objectives

- a. To locate sites for monitoring pollutants of interest from the main target sources.

### 2. Prevent Local Potential Sources of Sample Contamination

Factors affecting the chemical integrity of snow chemistry samples include:

#### a. Ground cover

Where possible, the sampling sites should be located on small, frozen bodies of water. If this is not feasible, sites should be located in a relatively secluded spots that are open, flat, and grass-covered to prevent local sources of sample contamination or contamination from the ground. A site area should be unaffected by melt for approximately 3 to 4 weeks to prevent leaching of ions and metals.

#### b. Nearby obstructions

Any of the following items can become a source of contamination for a snow chemistry sample, and should be avoided.

- Trees - fall through, splash, organic debris
- Buildings - splash, emissions
- Overhead wires - splash
- Air or ground traffic - emissions, dry deposition, windblown contaminants

Sites should be 2 to 3 heights (200 m) away from the nearest windbreak, i.e., tree, building, or other obstacle.

#### c. Site accessibility

All sites must be accessible and easily located by helicopter due to the nature of the local topography

and the number of sampling sites to be visited within 3 to 4 days. To prevent contamination or rotor-downwash during landings and takeoffs, the helicopter approach must be located several hundred meters downwind of the sampling site.

8.6 SNOWCORE SITE DESCRIPTIONS

The following is a list of snowcore site, including co-ordinates and descriptions.

Table 57. Snowcore site descriptions.

Station	ID	Co-ordinates		Description
Birch Mt. Lookout	BCH	6394800	450000	Middle of AFS strip.
Bitumount Lookout	HLS	6358000	467800	SE corner of radio tower lot.
Buckton Lookout	BKN	6414000	435000	AFS - west of tower.
Clark Creek	CLK	6295400	491600	Middle of slough to E of power line, flag tape on left side.
Dunkirk	DNK	6301000	397000	Middle of river at large bend, flagged.
Edra	ERA	6416000	366000	AFS strip - western end near fuel tanks.
Ells River	ELS	6331500	417500	0.6 km N of river, 3.2 km E of tributary.
Firebag	FBG	6388800	488300	S of little bridge on major river bend.
Fort McMurray Airport	FMA	6278300	486100	S of runway to E of large oil drums.
Gordon Lake	GLK	6276700	528900	On Campbell Lake, SE edge.
Grande Lookout	GND	6240000	424000	N end of AFS strip.
High Hills River	HHR	6302000	532000	In a slough W of HH river flagged in middle on N edge.
Johnson Lookout	JSN	6381000	541000	AFS strip - western edge near fuel tanks.
Long Rapid	LGR	6276500	442200	NW edge of lake.
Lost Creek	LCK	6346000	533000	Sm. pond to the SE at larger lake - 4 km part split in Firebag River.

Continued...

Table 57. Continued.

Station	ID	Co-ordinates		Description
Mackay River	MKR	6300000	421300	S of lake, 0.8 km from river.
Mildred Lake	N2	6324400	464500	Syncrude airstrip - to east of strip on pond.
Muskeg Lookout	MKG	6332000	506000	AFS strip - NW edge of strip, opposite sock.
Namur Lake	NLD	6362000	395000	SE edge of lake.
New Lake	NWL	6286000	509000	Not available.
Richardson	RIC	6415100	497700	Sm. lake with island to W of airstrip - land S of island.
Stony Mountain	SMT	6249100	482900	Opposite sm. mast.
Thickwood	NNWI	6335700	446800	Sm. lake, marked W of narrows.
Upper Tar Lake	UTL	6391000	421800	S side of lake W side of small bay.
Wolf Lake	WLK	6361600	450300	Follow cut line S of Calumet Lake.
Wood Creek	WCK	6304800	483300	S of outline, burned out of area, flag tape around trees.
E2		6321000	485700	Sm. pond, flagged to NE of site.
E4		6324000	497600	Sm. pond, flagged.
N1		6320900	466400	Off Hwy. 63 - N of Suncor's little lake, on cutline to east.
N4		6335800	461900	Junction of rivers.

Continued...

Table 57. Continued.

Station	ID	Co-ordinates	Description
NE1		6322900 477800	Pond, flagged.
NE3		6330100 475700	Sm. pond W of river, flagged.
NNE1		6330700 464400	S of island; east side of river.
NNE3		6341600 468900	Near edge of lake, flag tape.
NNE4		6346100 471900	Marked on N side of creek bend.
NW3		6321800 456800	1.6 km E of MacKay River, small pond marked with flag tape.
R0		6295000 475000	NW end of island.
R1		6309200 473300	Sand bar S of island.
R2		6313200 472700	20 m S of island to the east.
R3		6316500 473400	E side of river, opposite Suncor dyke.
R4		6321100 469800	NE of lower Syncrude tall tower.
SE3		6311700 484300	Middle of river, marked on E side of river.
SES		6306000 491500	Small pond.
SSW1		6299900 469400	In slough by cutline, flagged.

Continued...

Table 57. Concluded.

Station	ID	Co-ordinates	Description
SW1		6315800 466400	On hydro line, west of lines, E of trees.
SW3		6306500 461500	S edge, sm. beaver pond, flagged.
SW5		6296400 455900	N edge of lake.
W1		6316100 459700	Pond, flagged.
W3		6310300 447300	Beaver pond; follow power line, flagged.



8.7 SITE DOCUMENTATION FOR SNOWCORE SITES

The following is a suggested site documentation package to be followed for routine site evaluations.

AOSERP SITE DOCUMENTATION REPORT

I SITE IDENTIFICATION

Date \_\_\_\_\_ Operator \_\_\_\_\_

1. Station Name: \_\_\_\_\_
2. Station Number : \_\_\_\_\_
3. Latitude: \_\_\_\_\_° \_\_\_\_\_' \_\_\_\_\_" Longitude \_\_\_\_\_° \_\_\_\_\_' \_\_\_\_\_"
4. UTM Co-ordinates: \_\_\_\_\_
5. Elevation: \_\_\_\_\_ m
6. Type of Site (forest area, park area, body of water, gov't. facility, private property): \_\_\_\_\_  
\_\_\_\_\_
7. Site Markers Available: \_\_\_\_\_
8. Brief Description of How to Reach Site: \_\_\_\_\_  
\_\_\_\_\_  
\_\_\_\_\_
9. Time Required to Reach Site: \_\_\_\_\_
10. List Monitoring Instrumentation on Site, (Instruments - type, make, measurement): \_\_\_\_\_  
\_\_\_\_\_  
\_\_\_\_\_  
\_\_\_\_\_  
\_\_\_\_\_
11. Comments: \_\_\_\_\_  
\_\_\_\_\_  
\_\_\_\_\_  
\_\_\_\_\_  
\_\_\_\_\_



7. Where Do Snow and Dust Drift and Accumulate?:

---

8. Prevailing Wind Direction: \_\_\_\_\_

9. Daily Temperature & Weather Forecast: \_\_\_\_\_

10. List Deviations from Siting Criteria and All Advantages and Disadvantages of Site: \_\_\_\_\_

---

---

11. Prepare a Site Diagram Using the Legend on page 252.

Site Diagram

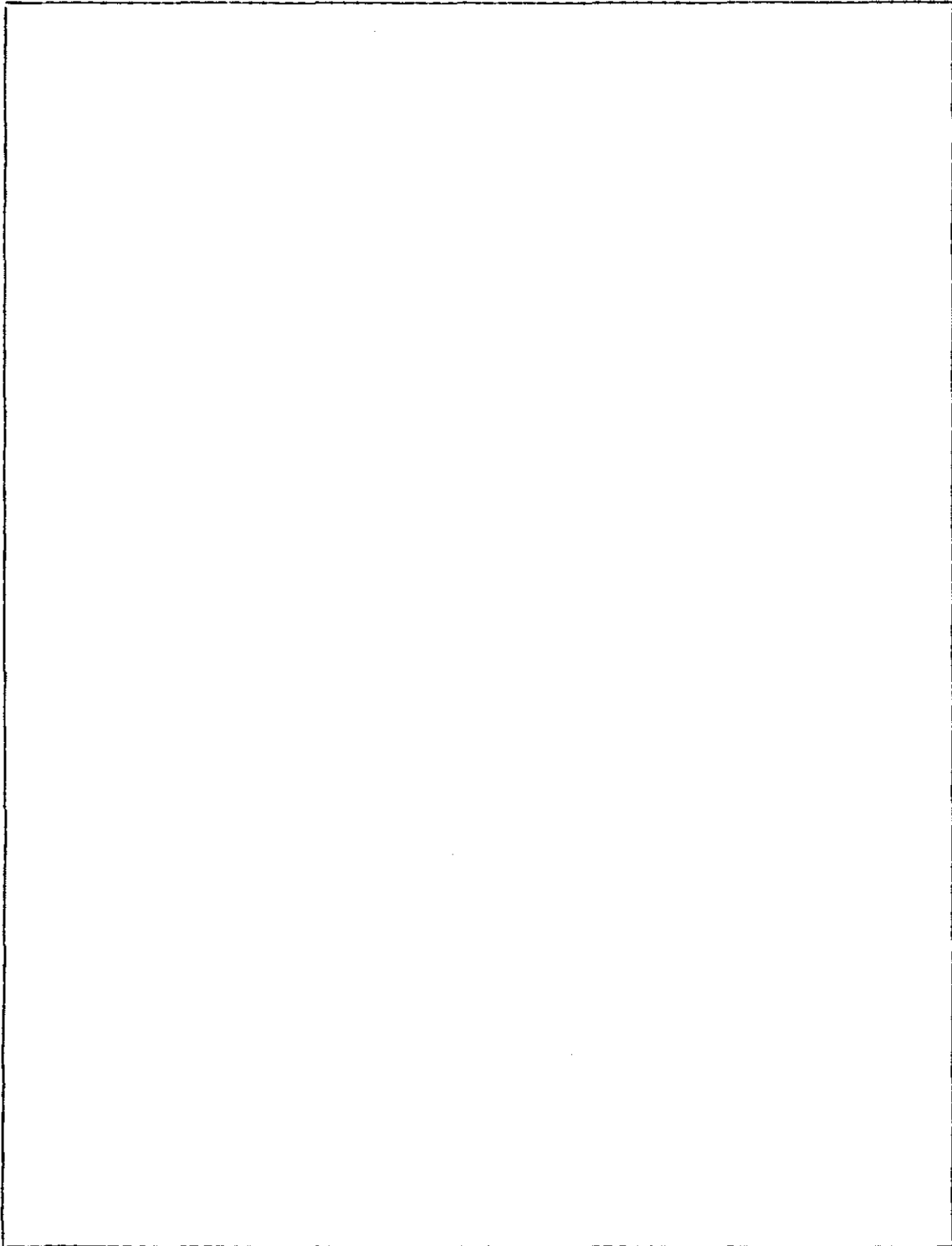

Prepared by: \_\_\_\_\_

Date: \_\_\_\_\_

Topographical Map



Prepared by: \_\_\_\_\_

Date: \_\_\_\_\_

Aerial Photographs

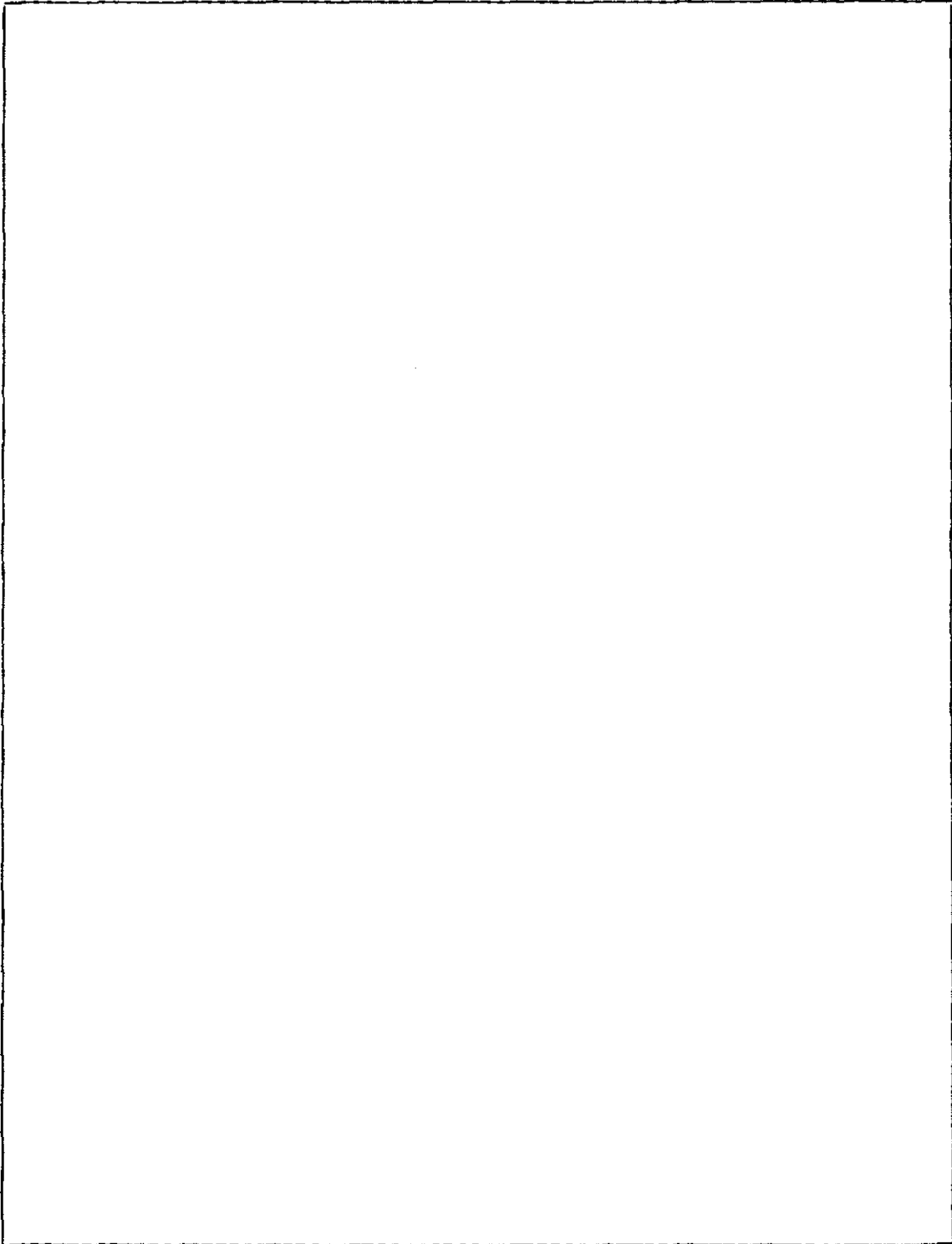

Prepared by: \_\_\_\_\_

Date: \_\_\_\_\_

Site Photographs

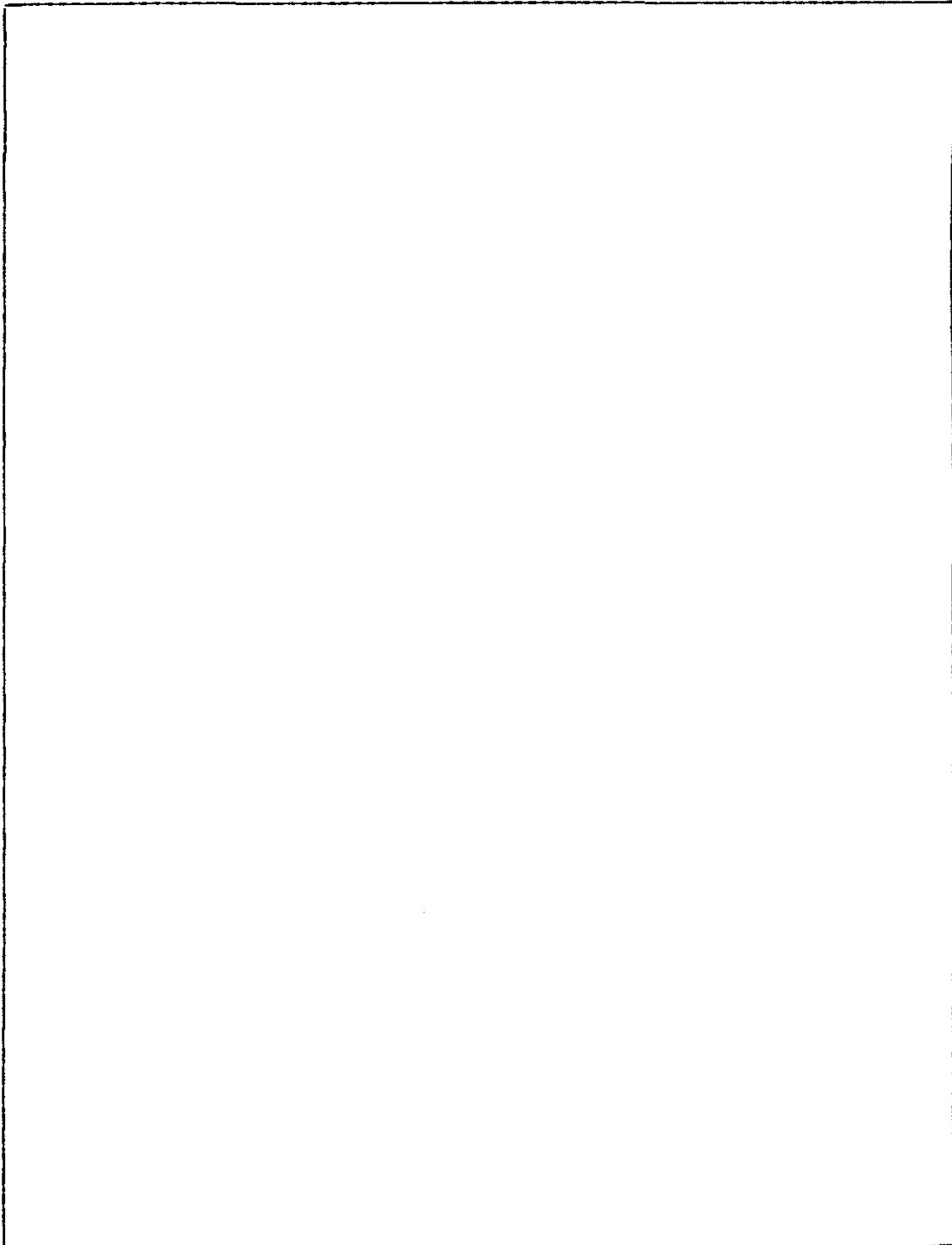

Prepared by: \_\_\_\_\_

Date: \_\_\_\_\_



## 8.8 SNOWCORE SAMPLING PROCEDURES (1976, 1978, and 1981)

The following outlines the sampling procedure for 1976, 1978 and 1981 as supplied by the Alberta environment department:

1. Measure snow depth;
2. Clean snow corer by inserting and removing it from the snowpack several times;
3. Insert sampler vertically to the bottom of the snowpack;
4. Clear snow from the plane face of the sampler;
5. Insert a shovel made of the same material as the corer, and having the same cross-section, under the lower end of the sampler;
6. Tilt the sampler until horizontal;
7. Remove the flat-faced side to expose the snowcore;
8. Measure core length and crust positions; and
9. Use the scoop to remove snow containing ground debris and slide the core into a plastic bag.<sup>a</sup>

---

<sup>a</sup> In 1976, the scoop was also used to separate the core into two sections.

## 8.9 SNOWCORE SAMPLING PROCEDURES (1983 and 1984)

The following outlines the snowcore sampling procedure for 1983 and 1984.

Supplies needed for each sample:

- 2 sampling bags
- 2 twist ties
- 1 label tag
- 1 metre stick
- 1 sampler
- 1 paddle scoop
- 1 recording sheet/clipboard/pencil

1. Land helicopter - on landing approach, the pilot should be aware of the purpose of the sample, and should land so that the personnel can walk approximately 100 m upwind (ahead) of helicopter. As much as possible, the snowpack should not be disturbed on landing.
2. Each person should be aware of individual responsibilities. One person should be responsible for recording and recording sheet, one person responsible for bags, sampler, and metre stick.
3. Walk to sampling site, being careful not to disturb the area immediately adjacent to the sampler area.
4. Remove the clean sampler from bag, run it through the snow to acclimatize it and remove possible debris remaining on the sampler.
5. Holding the sampler in a vertical position, slowly push sampler into snowpack to the bottom.
6. Measure snow depth by inserting the metre stick adjacent to the face of the sampler. Allow for parallax error by siting along the surface of the snow.
7. Clear snow away from front of sampler with the paddle. (Note: Paddle is also acrylic.)

8. Again, avoiding parallax error, measure and note (a) depth of any new snowfall, (b) position of any crusts, and (c) depth of snowcore in sampler.
9. Note bottom material (ice, grass, etc.).
10. Slip paddle directly under bottom of core and lift carefully into a horizontal position.
11. Check for contamination and remove by discarding the bottom portion of the core.
12. Measure length of core retained.
13. When an excessive amount of snow has been removed, the core should be discarded.
14. Grasp bag by outside faces and pour snow in without touching corer surfaces to the inner surface of the sample bag.
15. Repeat procedure until a large enough sample is obtained.
16. Secure bag with twist tie, label, put in second bag, seal, and label again.
17. Replace sampler in protective bag.
18. Put snow sample and sampler into unheated compartment of helicopter.
19. Plan for next stop, prepare recording sheet, lift off.

8.10 TERMS OF REFERENCE FOR THE CHEMICAL ANALYSIS OF WINTER  
PRECIPITATION FOR THE 1984 SURVEY

File: 82-36

February 29, 1984

Mr. D. C. LaBerge, Manager  
Analytical Services  
CHEMEX Labs (Alberta) Ltd.  
2021 - 41st Avenue, N.E.  
Calgary, Alberta  
T2E 6P2

Dear Mr. LaBerge:

Re: RMD Project No. 82-36  
Chemical Analysis of Winter Precipitation

Pursuant to our February 14 meeting, the Terms of Reference for the above project have been drafted and are attached. The Terms of Reference reflect the overall discussions and decisions rendered during this meeting which will expedite the overall achievement of the project's objectives. Would you please review this document carefully as it will form the basis for the subsequent contractual agreement.

Your confirmation and acceptance of the Terms of Reference are requested by signing in the space provided and returning a copy of this letter to me by March 05, 1984. Similarly, if you perceive that any amendments or additions are required, indicate them accordingly on the Terms of Reference and return a photocopy of them to me by March 05.

Yours truly,

Bonnie L. Magill  
Research Manager

BLM:smg  
Attachment

CONFIRMED AND ACCEPTED:

---

Mr. D. C. LaBerge

Schedule of Terms of Reference

1. The Contractor will analyze a maximum of 70 snow samples for each month January through March (total maximum of 210 samples) for the ions and metals specified in Table I employing the analytical procedures indicated.
2. The Contractor will analyze a maximum of 50 meltwater samples for the ions and metals specified in Table I employing the analytical procedures indicated.
3. To ensure the quality of the chemical analysis, the Contractor will perform the following routine procedures for each analytical technique used on a daily basis:
  - a calibration curve calculated from 5-7 standard samples will be constructed on the average for each set of 40 samples analyzed (the number of samples will vary depending on the analytical routine being used);
  - as every 20th and 21st sample, the calibration curve will be validated by analyzing 2 different standards, one in high and one in low concentration range;
  - a blank sample will be included as every 10th sample;
  - a calibration curve will be generated at the end of each day using 5-7 standard samples;
  - if sufficient volume of sample is left, replicate samples will be analyzed and standard deviations calculated; IC analysis first, then pH, then remainder of analysis depending on volume remaining after portion archived.
4. The Contractor will implement the following quality control (QC) program:
  - for 10% of the total number of samples received, a duplicate, spiked and diluted sample will be used to calculate recovery.
  - in collaboration with Scotty Miller of Alberta Environmental Centre, the Contractor will set up a QC program for 5% of the snow samples and will determine an appropriate QC for the melt-water analysis.
  - the Contractor will set up a QC program with Quanta-Trace for the metal analysis to be approved by RMD.

5. All calibration curves with calculation<sup>s</sup> used, details of quality control programs, and results of QC and routine procedures outlined above will be submitted to the project manager.
6. The Contractor will supply all bottles for the analyses of the snow samples. These bottles and caps will be rinsed with deionized water and then quality controlled at PH 4.5 and 6.0 to ensure that the bottles are not contaminated nor absorbed chemical constituents in expected concentration range; bottles to store samples for metal analysis will be acid washed using specified procedure and quality controlled.
7. The Minister will supply all bottles used in the collection and analysis of meltwater samples. These bottles will be acid-washed by the Contractor as per instructions furnished by the project manager and then quality controlled.
8. The contractor will implement the following procedures in the handling/storage of samples.
  - Snow Samples will be stored in freezers at -20 degrees celsius prior to analysis. Samples will thaw overnight in their original containers and then transferred into the QC sample bottles as follows:
    - (i) sample weight determined as specified in Table 1.
    - (ii) the outside of the sample collection bag will be rinsed with deionized water and shaken;
    - (iii) a corner of the bag will be cut and the sample will be transferred into the bottle.
    - (iv) a portion of each sample will be poured into an acid-washed QC bottle, preserved with a 0.2% solution of HNO<sub>3</sub> and shipped to Quanta. Trace for metal analysis.
    - (v) the remainder of the sample will be poured into water rinsed QC bottle for analysis as in Table 1. Samples will be analyzed for parameters in order of their stability (pH, HCO<sub>3</sub> within 12 Hrs. of thaw, acidity, gran plot filtration, anion scan and organic acids within 48 Hrs, remainder of analysis within 5 days). All thawed samples except during actual analysis are to be stored at 4 degrees celsius until analysis is complete.

All samples will be analyzed within two weeks of receipt.

- Meltwater samples will be stored at 4 degrees celsius until analysis and analyzed using procedures as outlined above for the snow samples.
- a full scan of all ions and organics will be run. This will determine the presence of silicates. All ions are to be treated as soluble (samples filtered prior to IC analysis). In the analyses for Ca and Mg, 25% of meltwater samples will be treated both as insoluble and soluble.

9. The Contractor will archive a portion of all samples for a maximum period of one year or until notification by the project manager; samples stored at 4 degrees celsius.
10. The Contractor will compute theoretical conductivity and compare to the actual conductivity.
11. The Contractor will compute the ion balance using the following equations:

$$IB = \frac{|\Sigma A - \Sigma C|}{1/2 (\Sigma A + \Sigma C)}$$

$\Sigma A$  = sum of ALL identified anions  
in  $\mu\text{eq/L}$

$\Sigma C$  = sum of ALL identified cations  
 $\mu\text{eq/L}$

12. Upon completion of the analysis, the Contractor will provide the project manager with a report delineating the results of all analyses (units  $\mu\text{eq/L}$ ) where applicable for each sample. The Contractor will also provide a log book delineating times of all procedures done.



### 8.11 DUPLICATE RESULTS

The following is a summary, by year, of the mean values, standard deviations, and the relative standard deviations for all parameters analysed for both the summer and winter precipitation studies.

Table 58. Laboratory duplicate data - the AOSERP summer precipitation study 1981.

Parameter	Number of Duplicate Results	Mean	Standard Deviation	Relative Standard Deviation (%)
Dissolved Metals				
Al	16	0.017	0.017	101
Be	16	0.001	0.000	0.0
Cd	16	0.005	0.001	19.2
Cr	16	0.001	0.000	0.0
Cu	16	0.0005	0.000	0.0
Fe	14	0.019	0.017	91.0
Mn	16	0.007	0.008	113
Ni	16	0.001	0.000	0.0
Pb	16	0.006	0.000	0.0
Sn	16	0.003	0.000	0.0
Sr	16	0.001	0.000	0.0
Ti	16	0.0005	0.000	0.0
V	16	0.003	0.004	153
Zn	16	0.000	0.001	NA
Co	16	0.001	0.000	0.0
Cl <sup>-</sup>	7	0.059	0.007	12.0
K <sup>+</sup>	5	0.005	0.000	0.0
Na <sup>+</sup>	5	0.036	0.005	12.5

NA - not applicable

Table 59. Laboratory duplicate data - the AOSERP summer precipitation study 1982.

Parameter	Number of Duplicate Results	Mean	Standard Deviation	Relative Standard Deviation (%)
F <sup>-</sup>	27	0.007	0.0002	3.4
pH	21	5.08	0.021	0.4
NH <sub>4</sub> <sup>+</sup>	30	0.359	0.061	17.0
NO <sub>3</sub> <sup>-</sup>	31	0.474	0.082	17.3
PO <sub>4</sub> <sup>3-</sup>	31	0.035	0.014	40.9
SO <sub>4</sub> <sup>2-</sup>	31	0.925	0.059	6.4
Specific Conductivity	21	8.07	0.087	1.1
Ca <sup>2+</sup>	28	0.229	0.016	7.0
Cl <sup>-</sup>	31	0.149	0.022	14.8
K <sup>+</sup>	30	0.099	0.038	37.9
Na <sup>+</sup>	30	0.085	0.076	90.0
Mg <sup>2+</sup>	29	0.024	0.001	6.0

Table 60. Laboratory duplicate data - the AOSERP summer precipitation study 1983.

Parameter	Number of Duplicate Results	Mean	Standard Deviation	Relative Standard Deviation (%)
pH	13	5.85	0.081	1.3
NH <sub>4</sub> <sup>+</sup>	11	0.102	0.002	2.3
NO <sub>3</sub> <sup>-</sup>	11	0.676	0.006	0.9
PO <sub>4</sub> <sup>3-</sup>	11	0.065	0.000	0.0
SO <sub>4</sub> <sup>2-</sup>	9	0.664	0.006	0.9
Specific Conductivity	13	181.8	3.74	2.1
Ca <sup>2+</sup>	13	0.047	0.003	6.2
Cl <sup>-</sup>	8	0.327	0.011	3.4
K <sup>+</sup>	11	0.906	0.011	1.2
Na <sup>+</sup>	10	0.106	0.003	2.4
Mg <sup>2+</sup>	13	0.025	0.002	7.3

Table 61. Laboratory duplicate data - the AOSERP summer precipitation study 1984.

Parameter	Number of Duplicate Results	Mean	Standard Deviation	Relative Standard Deviation (%)
$\text{NH}_4^+$	29	0.072	0.034	46.5
$\text{NO}_2^-$	34	0.003	0.003	90.1
$\text{NO}_3^-$	34	0.107	0.003	2.6
$\text{PO}_4^{3-}$	34	0.002	0.0004	20.1
$\text{SO}_4^{2-}$	34	0.769	0.013	1.7
$\text{Ca}^{2+}$	27	0.107	0.048	45.1
$\text{Cl}^-$	34	0.045	0.016	34.3
$\text{K}^+$	33	0.027	0.006	20.6
$\text{Na}^+$	33	0.026	0.015	5.6
$\text{Mg}^{2+}$	26	0.013	0.004	31.1

Table 62. Laboratory duplicate data - the AOSERP summer precipitation program.

Selected Parameters	Summer 1981	Summer 1982	Summer 1983	Summer 1984	Comparison of the Summer Data Using the RSD Values From 1981 to 1984
	RSD (%)	RSD (%)	RSD (%)	RSD (%)	
Ca <sup>2+</sup>	-	7.0	6.2	45.1	The degree of scatter has increased.
K <sup>+</sup>	0	37.9	1.2	20.6	The degree of scatter has decreased.
Na <sup>+</sup>	12.5	90.0	2.4	5.6	The degree of scatter has fluctuated between years.
Mg <sup>2+</sup>	-	6	7.3	31.1	The degree of scatter has increased.
NH <sub>4</sub> <sup>+</sup>	-	17	2.3	46.5	The degree of scatter has decreased.
pH	-	0.4	1.3	-	The degree of scatter has increased.
Cl <sup>-</sup>	12	14.8	3.4	34.3	The degree of scatter has decreased.
NO <sub>3</sub> <sup>-</sup>	-	17.3	0.9	2.6	The degree of scatter has decreased.
SO <sub>4</sub> <sup>2-</sup>	-	6.4	-	1.7	The degree of scatter has decreased.
PO <sub>4</sub> <sup>3-</sup>	-	40.9	0	20.1	The degree of scatter has fluctuated between years.

Table 63. Laboratory duplicate data - the AOSERP winter precipitation study 1984.

Parameter (mg·L <sup>-1</sup> ) unless otherwise stated	Dissolved				Undissolved			
	Number of Duplicate Results	Mean	Standard Deviation	Relative Standard Deviation	Number of Duplicate Results	Mean	Standard Deviation	Relative Standard Deviation
Mg	23	0.070	0.003	3.0	18	0.104	0.005	5.1
Mn	23	0.003	0.001	18.0	18	0.009	0.001	9.2
Mo	23	0.005	0.000	0	18	0.002	0.0002	10.5
Na	23	0.077	0.019	25	18	0.096	0.009	9.2
Ni	23	0.005	0.000	0	18	0.035	0.003	8.0
P	23	0.050	0.000	0	18	0.011	0.004	34
Pb	23	0.025	0.000	0	18	0.003	0.001	19.2
Sb	23	0.025	0.000	0	18	0.001	0.0004	33
Se	23	0.025	0.000	0	18	0.001	0.0004	33
Si	23	0.004	0.000	0	18	0.004	0.001	30
Sr	23	0.001	0.0002	19	18	0.003	0.0003	13.6
Th	23	0.050	0.000	0	18	0.001	0.0002	28
Ti	23	0.001	0.000	0	18	0.103	0.007	7.1
U	23	0.150	0.000	0	18	0.004	0.001	21.3
V	23	0.009	0.0002	2.2	18	0.086	0.006	6.5
Zn	23	0.006	0.0002	31	18	0.002	0.0003	15.8
Zr	23	0.003	0.000	0	18	0.004	0.0003	8.6
Al	23	0.010	0.000	0	18	1.06	0.11	10.4
As	23	0.10	0.000	0	18	0.004	0.001	21
B	23	0.046	0.000	0	18	0.0004	0.0001	27
Ba	23	0.001	0.0001	6.2	18	0.007	0.001	12.4
Be	23	0.001	0.000	0	18	0.00003	0.00005	1.5
Bi	23	0.10	0.000	0	18	0.003	0.001	32
Ca	23	0.617	0.097	15.7	18	0.148	0.018	12.2
Cd	23	0.001	0.000	0	18	0.00007	0.00002	25.4
Cr	23	0.001	0.000	0	18	0.003	0.0003	9.6
Cu	23	0.003	0.001	25	18	0.001	0.0001	13.8
Fe	23	0.003	0.0003	12	18	0.433	0.054	12.5
Hg	23	0.025	0.000	0	18	0.001	0.004	35
K	23	0.100	0.000	0	18	0.217	0.021	9.7
Li	23	0.025	0.000	0	18	0.001	0.0004	30
Co	23	0.025	0.000	0	18	0.001	0.0001	9.7
pH	2	5.17	0.014	2.7				
NH <sub>4</sub> <sup>+</sup>	2	0.016	0.005	29				
NO <sub>2</sub> <sup>-</sup>	2	0.003	0.002	54				
NO <sub>3</sub> <sup>-</sup>	2	0.091	0.003	2.7				
PO <sub>4</sub> <sup>2-</sup>	2	0.003	0.000	0				
SO <sub>4</sub> <sup>2-</sup>	2	0.40	0.000	0				
Alkalinity	2	4.67	0.480	10.2				
Conductivity	2	4.95	0.071	1.4				
Ca <sup>2+</sup>	2	0.360	0.045	12.5				
Cl <sup>-</sup>	2	0.060	0.021	35				
K <sup>+</sup>	2	0.014	0.018	129				
Na <sup>+</sup>	2	0.056	0.013	23				
Mg <sup>2+</sup>	2	0.022	0.025	114				
Acidity (μequ·L <sup>-1</sup> )	2	0.0050	0.000	0				
Total Acidity (μequ·L <sup>-1</sup> )	2	45.5	2.8	6.1				
Strong Acid Titrable (μequ·L <sup>-1</sup> )	2	10.4	0.1	1				

Table 64. Laboratory duplicate data - the AOSERP winter precipitation program in comparison to the AOSERP summer precipitation program.

Selected Parameters	Summer 1984	Winter 1984
	RSD (%)	RSD (%)
Ca <sup>2+</sup>	45.1	12.5
K <sup>+</sup>	20.6	129
Na <sup>+</sup>	5.6	23
Mg <sup>2+</sup>	31.1	114
NH <sub>4</sub> <sup>+</sup>	46.5	29
Cl <sup>-</sup>	34.3	35
NO <sub>3</sub> <sup>-</sup>	2.6	2.7
SO <sub>4</sub> <sup>2-</sup>	1.7	0
PO <sub>4</sub> <sup>3-</sup>	20.1	0



#### 8.12 REPLICATE RESULTS

The following are the tabulated mean and standard deviations of the replicate results for both the summer and winter precipitation studies.

Table 65. Replicate data - the AOSERP summer precipitation study 1976.

Parameter	Number of Replicate Results	Mean	Standard Deviation	Relative Standard Deviation (%)
$\text{NH}_4^+$	8	0.073	0.072	98.6
$\text{NH}_4^+ - \text{N}$	4	0.074	0.021	28.4
$\text{NO}_3^-$	8	0.061	0.019	31.2
$\text{NO}_3^- - \text{N}$	4	0.033	0.014	42.4
$\text{PO}_4^{3-}$	4	0.01	0.00	0
$\text{SO}_4^{2-}$	8	0.091	0.038	41.8
$\text{SO}_4^{2-} - \text{S}$	4	0.125	0.05	40.0
Alkalinity	6	83.0	70.0	84.3
Specific Conductivity	12	4.59	2.12	46.2
Field pH	8	2.57	0.136	5.3
Laboratory pH	7	5.47	0.206	3.8
$\text{Ca}^{2+}$	10	0.098	0.132	135
$\text{Cl}^-$	12	0.240	0.210	87.5
$\text{K}^+$	10	0.147	0.0986	67.3
$\text{Na}^+$	10	0.033	0.04	121
$\text{Mg}^{2+}$	10	0.065	0.023	35.4
$\text{HCO}_3^-$	3	2.95	0.969	32.8

Table 66. Replicate data - the AOSERP summer precipitation study 1977.

Parameter	Number of Replicate Results	Mean	Standard Deviation	Relative Standard Deviation (%)
$\text{NH}_4^+$	2	0.095	0.010	10.5
$\text{NH}_4^+ - \text{N}$	2	0.095	0.010	10.5
$\text{NO}_3^-$	2	0.058	0.011	19.5
$\text{NO}_3^- - \text{N}$	2	0.058	0.011	19.5
$\text{PO}_4^{3-}$	5	0.227	0.158	69.6
$\text{SO}_4^{2-}$	5	0.227	0.158	69.6
Specific Conductivity	6	11.7	10.7	90.9
Field pH	6	2.41	0.246	10.2
Laboratory pH	2	5.39	0.210	3.9
$\text{Ca}^{2+}$	6	0.107	0.098	91.6
$\text{Cl}^-$	10	0.865	0.101	11.
$\text{K}^+$	6	0.361	0.536	148.
$\text{Na}^+$	6	0.338	0.453	134.
$\text{Mg}^{2+}$	6	0.090	0.086	95.6
$\text{HCO}_3^-$	2	3.01	1.91	63.4

Table 67. Replicate data - the AOSERP summer precipitation study 1978.

Parameter	Number of Replicate Results	Mean	Standard Deviation	Relative Standard Deviation (%)
$\text{NH}_4^+$ - N	3	0.062	0.012	19.6
$\text{NO}_3^-$ - N	3	0.057	0.008	14.4
$\text{SO}_4^{2-}$ - S	3	0.416	0.048	11.5
Alkalinity	2	27.1	17.8	66
Specific Conductivity	3	7.5	2.1	28
Laboratory pH	2	5.72	8.52	149
$\text{Ca}^{2+}$	3	0.11	0.0	0
$\text{Cl}^-$	3	0.04	0.0	0
$\text{K}^+$	3	0.11	0.012	11.6
$\text{Na}^+$	3	0.09	0.037	43
$\text{Mg}^{2+}$	3	0.10	0.0	0

Table 68. Replicate data - the AOSERP summer precipitation study 1979.

Parameter	Number of Replicate Results	Mean	Standard Deviation	Relative Standard Deviation (%)
$\text{NH}_4^+$	2	0.150	0.114	76
$\text{NH}_4^+ - \text{N}$	2	0.150	0.114	76
$\text{NO}_3^-$	2	0.103	0.066	64.1
$\text{NO}_3^- - \text{N}$	2	0.103	0.066	64.1
$\text{SO}_4^{2-}$	2	0.550	0.255	46.4
$\text{SO}_4^{2-} - \text{S}$	2	0.550	0.255	46.4
Alkalinity	2	0.100	0.0	0
Specific Conductivity	4	14.9	3.68	24.6
Laboratory pH	2	4.62	0.23	4.8
$\text{Ca}^{2+}$	4	0.081	0.01	12.3
$\text{Cl}^-$	4	0.375	0.323	86.1
$\text{K}^+$	4	0.095	0.40	42.2
$\text{Na}^+$	4	0.140	0.080	57.1
$\text{Mg}^{2+}$	4	0.550	0.070	12.7
$\text{HCO}_3^-$	2	0.235	0.165	70.2

Table 69. Replicate data - the AOSERP summer precipitation study 1981.

Parameter	Number of Replicate Results	Mean	Standard Deviation	Relative Standard Deviation (%)
F <sup>-</sup>	16	0.077	0.014	18.3
pH	17	4.64	0.086	1.8
NH <sub>4</sub> <sup>+</sup>	18	0.498	0.143	28.9
NO <sub>3</sub> <sup>-</sup>	18	1.30	0.363	27.9
PO <sub>4</sub> <sup>3-</sup>	18	0.033	0.053	161
SO <sub>4</sub> <sup>2-</sup>	18	2.57	0.168	6.5
Specific Conductivity	17	20.1	27.4	136
Ca <sup>2+</sup>	18	0.224	0.019	8.5
Cl <sup>-</sup>	18	0.092	0.043	47
K <sup>+</sup>	18	0.140	0.097	69.3
Na <sup>+</sup>	18	0.069	0.053	76.8
Mg <sup>2+</sup>	18	0.057	0.010	17.7

Table 70. Replicate data - the AOSERP summer precipitation study 1982.

Parameter	Number of Replicate Results	Mean	Standard Deviation	Relative Standard Deviation (%)
F <sup>-</sup>	2	0.050	0.00	0
pH	3	5.17	0.465	9.0
NH <sub>4</sub> <sup>+</sup>	4	0.266	0.082	30.8
NO <sub>3</sub> <sup>-</sup>	4	0.704	0.177	25.1
PO <sub>4</sub> <sup>3-</sup>	4	0.069	0.069	99.4
SO <sub>4</sub> <sup>2-</sup>	4	1.27	0.202	15.9
Specific Conductivity	3	8.07	4.3	53.3
Ca <sup>2+</sup>	4	0.505	0.058	11.5
Cl <sup>-</sup>	4	0.125	0.019	15.2
K <sup>+</sup>	4	0.081	0.032	39.5
Na <sup>+</sup>	4	0.035	0.009	24.9
Mg <sup>2+</sup>	4	0.10	0	0

Table 71. Replicate data - the AOSERP summer precipitation study 1983.

Parameter	Number of Replicate Results	Mean	Standard Deviation	Relative Standard Deviation (%)
pH (unspecified)	81	4.54	0.086	1.89
NH <sub>4</sub> <sup>+</sup>	69	0.180	0.063	35
NO <sub>3</sub> <sup>-</sup>	69	0.482	0.038	7.9
PO <sub>4</sub> <sup>3-</sup>	21	0.062	0.041	66.1
SO <sub>4</sub> <sup>2-</sup>	69	1.75	0.173	9.9
Specific Conductivity	81	22.2	3.79	16.6
Ca <sup>2+</sup>	69	0.088	0.023	26.1
Cl <sup>-</sup>	69	0.048	0.022	46
K <sup>+</sup>	69	0.030	0.016	52.6
Na <sup>+</sup>	69	0.033	0.02	59.5
Br	13	0.005	0.006	124
Mg <sup>2+</sup>	69	0.016	0.005	31.7
Acidity (strong titratable)	11	95.9	7.58	7.9
Al (undissolved)	24	1.32	0.28	21.2
Ca (undissolved)	24	0.228	0.037	16.1
Cl (undissolved)	24	0.598	0.127	21.2
Fe (undissolved)	24	0.952	0.167	17.5
K (undissolved)	24	0.489	0.082	16.7
S (undissolved)	24	0.416	0.056	13.5
Si (undissolved)	24	3.75	0.786	21
Ti (undissolved)	24	0.174	0.037	21.3



Table 72. Replicate data - the AOSERP summer precipitation study 1984.

Parameter	Number of Replicate Results	Mean	Standard Deviation	Relative Standard Deviation (%)
$\text{NH}_4^+$	7	0.110	0.057	52
$\text{NO}_2^-$	7	0.002	0.001	54.4
$\text{NO}_3^-$	7	0.125	0.148	118
$\text{PO}_4^{3-}$	7	0.003	0.00	0
$\text{SO}_4^{2-}$	7	1.01	0.565	56
Alkalinity	4	30.1	10.6	35.3
Specific Conductivity	5	8.95	4.51	50.4
Laboratory pH	5	5.02	0.344	6.8
$\text{Ca}^{2+}$	7	0.293	0.429	146
$\text{Cl}^-$	7	0.06	0.06	100
$\text{K}^+$	7	0.032	0.038	119
$\text{Na}^+$	7	0.036	0.026	72.2
$\text{Mg}^{2+}$	7	0.031	0.053	171
Acidity	1	117	2.83	2.4

Table 73. Replicate data - the AOSERP winter precipitation study 1976.

Parameter	Number of Replicate Results	Mean	Standard Deviation	Relative Standard Deviation (%)
Sulphur "S" (top of core)	3	0.242	0.065	26.8
Sulphur "S" (bottom of core)	3	0.268	0.103	38.5
Conductivity (top of core)	3	9.25	2.18	23.5
Conductivity (bottom of core)	3	16.1	11.9	73.6
pH (top of core)	3	5.66	0.058	1.02
pH (bottom of core)	3	6.633	0.820	12.4

Table 74. Replicate data - the AOSERP winter precipitation study 1978.

Parameter	Number of Replicate Results	Mean	Standard Deviation	Relative Standard Deviation (%)
$\text{NH}_4^+$ - N $\text{mg}\cdot\text{L}^{-1}$	16	0.063	0.026	41.1
$\text{NO}_3^-$ $\text{mg}\cdot\text{L}^{-1}$	16	0.145	0.022	15.4
$\text{SiO}_2^-$ $\text{mg}\cdot\text{L}^{-1}$	16	0.026	0.008	30.0
$\text{SO}_4^{2-}$ $\text{mg}\cdot\text{L}^{-1}$	12	0.344	0.025	7.31
Alkalinity	16	16.0	6.12	38.3
Field pH	16	5.39	0.168	3.11
Laboratory pH	16	5.68	0.176	3.09
$\text{Ca}^{2+}$	16	0.426	0.099	23.2
$\text{Cl}^-$	16	0.055	0.021	38.4
$\text{K}^+$	16	0.047	0.031	66.3
$\text{Na}^+$	16	0.08	0.044	54.4
$\text{Mg}^{2+}$	16	0.094	0.025	26.7
Al (dissolved)	14	0.003	0.002	38.6
Fe (dissolved)	14	0.003	0.001	35.2
Ni (dissolved)	14	0.003	0.0003	8.69
V (dissolved)	16	0.024	0.002	6.60

Table 75. Replicate data - the AOSERP winter precipitation study 1981.

Parameter	Number of Replicate Results	Mean	Standard Deviation	Relative Standard Deviation (%)
Al	18	0.0093	0.0084	90.7
Fe	18	0.012	0.0105	84.9
Ni	18	0.003	0.0034	94
V	18	0.027	0.0139	50.8
pH	18	6.34	0.809	12.7
NH <sub>4</sub> <sup>+</sup>	14	0.090	8.04	48.8
NO <sub>3</sub> <sup>-</sup>	18	0.115	0.0176	0.152
SO <sub>4</sub> <sup>2-</sup>	18	0.542	0.154	28.4
Alkalinity	18	87.2	114	131
Ca <sup>2+</sup>	18	1.38	1.35	98
Cl <sup>-</sup>	13	0.112	0.102	91.4
K <sup>+</sup>	11	0.505	0.102	20.1
Na <sup>+</sup>	16	0.459	0.398	86.6
Mg <sup>2+</sup>	18	0.544	0.450	82.7

Table 76. Replicate data - the AOSERP winter precipitation study 1983.

Parameter	Number of Replicate Results	Mean	Standard Deviation	Relative Standard Deviation (%)
F <sup>-</sup>	15	0.025	0.000	0
pH	19	4.76	0.133	2.79
NH <sub>4</sub> <sup>+</sup>	17	0.174	0.046	26.2
NO <sub>3</sub> <sup>-</sup>	17	0.788	0.032	2.78
PO <sub>4</sub> <sup>3-</sup>	17	0.017	0.021	122
SO <sub>4</sub> <sup>2-</sup>	17	0.767	0.04	5.16
Specific Conductivity	19	10.1	2.14	21.2
Laboratory pH	19	19.5	5.86	30.1
Ca <sup>2+</sup>	19	0.095	0.079	83.4
Cl <sup>-</sup>	17	0.058	0.041	70.1
K <sup>+</sup>	17	0.028	0.057	201
Na <sup>+</sup>	17	0.37	0.098	267
Mg <sup>2+</sup>	19	0.02	0.02	81.2

Table 77. Replicate data - the AOSERP winter precipitation study 1984.

Parameter	Number of Replicate Results	Mean	Standard Deviation	Relative Standard Deviation (%)
$PO_4^{3-}$	16	0.003	0.0004	12.3
$SO_4^{2-}$	16	3.11	9.63	309
CO	13	0.003	0.000	0
Alkalinity	13	41	15.4	37.5
Specific Conductivity	16	11.7	3.18	27.2
$Ca^{2+}$	16	0.894	0.361	40.4
$Cl^-$	16	0.103	0.233	227
$K^+$	16	0.050	0.014	28.9
$Na^+$	16	0.102	0.021	20.8
$Mg^{2+}$	16	0.154	0.037	24.0
Acidity Total Titratable	15	47.8	3.89	8.1
Acidity Strong Titratable	15	15.5	3.62	23.3
Acidity	16	0.091	0.344	377

Table 78. Replicate data - the AOSERP winter precipitation study 1984.

Parameter	DISSOLVED				UNDISSOLVED			
	Number of Replicate Results	Mean	Standard Deviation	Relative Standard Deviation (%)	Number of Replicate Results	Mean	Standard Deviation	Relative Standard Deviation (%)
Al	13	0.010	0.000	0	15	5.18	5.32	102.7
As	13	0.100	0.000	0	15	0.004	0.0004	9.78
B	13	0.005	0.000	0	15	0.0007	0.0009	135.1
Ba	13	0.002	0.0004	23.0	15	0.037	0.0396	107.9
Be	13	0.0005	0.000	0	15	0.00014	0.00014	97.2
Bi	13	0.100	0.000	0	15	0.003	0.002	50.84
Ca	13	0.972	0.376	38.7	15	0.79	0.629	78.8
Cd	13	0.001	0.000	0	15	0.00008	0.00004	50.66
Cr	13	0.001	0.000	0	15	0.006	0.006	114.3
Cu	13	0.003	0.000	0	15	0.002	0.027	11.13
Fe	13	0.005	0.005	102	15	2.49	2.39	95.0
Hg	13	0.025	0.000	0	15	0.0015	0.0008	52.1
K	13	0.100	0.000	0	15	1.341	1.38	104
Li	13	0.025	0.000	0	15	0.0032	0.0036	111
Mg	13	0.177	0.047	26.7	15	0.601	0.498	82.9
Mn	13	0.006	0.001	17.8	15	0.036	0.038	107
Mo	13	0.006	0.0014	24.0	15	0.004	0.004	85.4

continued ...

Table 78. Concluded.

Parameter	DISSOLVED				UNDISSOLVED			
	Number of Replicate Results	Mean	Standard Deviation	Relative Standard Deviation (%)	Number of Replicate Results	Mean	Standard Deviation	Relative Standard Deviation (%)
Na	13	0.098	0.027	27.4	15	0.378	0.308	81.5
Ni	13	0.005	0.000	0	15	0.072	0.133	184.8
P	13	0.050	0.000	0	15	0.044	0.044	100
Pb	13	0.025	0.000	0	15	0.005	0.006	134.7
Sb	13	0.025	0.000	0	15	0.00015	0.0008	51.8
Se	13	0.025	0.000	0	15	0.001	0.0008	0.52
Si	13	0.025	0.000	0	15	0.0174	0.044	252.8
Sr	13	0.002	0.0005	25.0	15	0.010	0.011	103
Th	13	0.050	0.000	0	15	0.0008	0.0004	51.0
Ti	13	0.0005	0.000	0	15	0.246	0.348	142
U	13	0.150	0.000	0	15	0.004	0.002	53.8
V	13	0.01	0.004	37.1	15	0.179	0.333	186
Zn	13	0.003	0.0008	30.7	15	0.007	0.007	95.7
Zr	13	0.003	0.000	0	15	0.010	0.014	138
pH	15	5.86	0.149	2.5				
NH <sub>4</sub> <sup>+</sup>	16	0.118	0.032	27.2				
NO <sub>2</sub> <sup>-</sup>	16	0.567	2.25	396				
NO <sub>3</sub> <sup>-</sup>	16	0.125	0.017	134				



8.13 SAMPLER COLLECTION EFFICIENCIES

The following is a summary of the daily efficiencies for rain samplers in the AOSERP summer precipitation network.

Table 79. Summary of the daily efficiencies for rain samplers in the AOSERP summer precipitation network.

year	station	month	day	hh	mm	s_vol	s_voltot	count	aesrngg	eff	
81	5	5	17	7	0	11.70	11.70	1	23.000	3.2	
			18	18	0	27.00	27.00	1	6.000	28.3	
		6	3	0	0	299.00	299.00	1	115.000	16.3	
			6	0	0	818.00	818.00	1	123.000	41.8	
			7	0	0	629.00	629.00	1	158.000	25.0	
			18	0	0	92.00	92.00	1	9.000	64.3	
			19	0	0	156.00	156.00	1	16.000	61.3	
			21	0	0	119.00	119.00	1	22.000	34.0	
			24	0	0	411.00	975.00	3	49.000	125.1	
				19	25	411.00	975.00	3	49.000	125.1	
				21	0	153.00	975.00	3	49.000	125.1	
			26	15	0	109.00	178.00	2	17.000	65.8	
				17	25	69.00	178.00	2	17.000	65.8	
			27	11	45	132.00	406.00	3	72.000	35.5	
					46	?	406.00	3	72.000	35.5	
				12	50	100.00	406.00	3	72.000	35.5	
					51	?	406.00	3	72.000	35.5	
				16	10	174.00	406.00	3	72.000	35.5	
			28	15	5	195.00	195.00	1	23.000	53.3	
		7	6	12	30	2536.00	2536.00	1	3.000	5315.2	
					31	?	2536.00	1	3.000	5315.2	
			21	0	0	2040.00	2040.00	1	289.000	44.4	
			23	0	0	118.00	118.00	1	40.000	18.5	
					1	?	118.00	1	40.000	18.5	
		8	1	15	30	490.00	490.00	1	36.000	85.6	
			2	14	50	2760.00	2760.00	1	203.000	85.5	
			3	13	50	249.00	249.00	1	21.000	74.6	
			9	1	16	0	382.00	382.00	1	40.000	60.0
		6	5	17	7	10	304.60	304.60	1	36.000	53.2
			6	3	0	0	704.00	704.00	1	102.000	43.4
				8	0	0	402.00	402.00	1	35.000	72.2
				18	0	0	537.00	537.00	1	52.000	64.9
				22	0	0	287.00	287.00	1	66.000	27.3
			7	7	16	20	1620.00	1620.00	1	185.000	55.1
				21	0	0	818.00	818.00	1	78.000	65.9
				23	0	0	519.00	519.00	1	50.000	65.3
			8	1	15	30	695.00	812.00	2	94.000	54.3
					17	30	117.00	812.00	2	94.000	54.3
		15	5	1	7	50	261.10	261.10	1	10.000	164.2
				2	7	50	144.50	203.40	2	16.000	79.9
					13	5	58.90	203.40	2	16.000	79.9
				17	7	15	111.10	111.10	1	14.000	49.9
				18	18	20	198.80	198.80	1	15.000	83.3
			6	3	0	0	690.00	1797.00	2	123.000	91.9
							?	1797.00	2	123.000	91.9
					1	968.00	1797.00	2	123.000	91.9	
i2	i4	i2	i2	i2	i2	f4.2	f4.2	i6	f6.3	f3.1	

continued ...

Table 79. Continued.

year	station	month	day	hh	mm	s_vol	s_voltot	count	aesrngg	eff
81	15	6	3	1	0	968.00	1797.00	2	123.000	91.9
			4	0	0	14.00	14.00	1	15.000	5.9
			6	0	0	181.00	181.00	1	31.000	36.7
			7	0	0	32.00	32.00	1	17.000	11.8
			8	0	0	638.00	638.00	1	62.000	64.7
			14	0	0	111.00	111.00	1	11.000	63.4
			15	0	0	355.00	344.00	2	66.000	32.8
					1	111.00	344.00	2	66.000	32.8
				1	0	111.00	344.00	2	66.000	32.8
			21	0	0	243.00	243.00	1	19.000	80.4
			29	20	0	219.00	219.00	1	9.000	153.0
		7	5	15	35	67.00	67.00	1	4.000	105.3
			7	9	40	3176.00	3176.00	1	226.000	88.4
					41	?	3176.00	1	226.000	88.4
			21	0	0	964.00	964.00	1	66.000	91.8
			23	0	0	73.00	73.00	1	9.000	51.0
			27	9	15	233.00	233.00	1	22.000	66.6
			28	13	30	4.00	4.00	1	2.000	12.6
		8	1	19	35	122.00	122.00	1	79.000	9.7
		9	1	16	40	90.00	90.00	1	14.000	40.4
	28	5	27	0	0	1367.00	1367.00	1	170.000	50.6
		6	6	0	0	563.00	563.00	1	66.000	53.6
			9	0	0	559.00	559.00	1	36.000	97.6
			21	0	0	869.00	869.00	1	90.000	60.7
		7	7	8	15	1917.00	3269.00	2	312.000	65.9
				22	0	1352.00	3269.00	2	312.000	65.9
			11	17	0	1066.00	1066.00	1	147.000	45.6
			13	19	30	307.00	307.00	1	22.000	87.7
			20	0	0	693.00	693.00	1	4.000	1089.3
			28	16	0	248.00	248.00	1	15.000	104.0
		8	2	21	0	695.00	695.00	1	50.000	87.4
			20	19	0	409.00	409.00	1	75.000	34.3
	29	5	1	19	35	283.80	283.80	1	46.000	38.8
			20	8	30	119.20	119.20	1	24.000	31.2
		6	6	0	0	42.00	42.00	1	79.000	3.3
			15	0	0	159.00	159.00	1	13.000	76.9
			18	0	0	787.00	787.00	1	56.000	88.4
		7	22	0	0	1360.00	1360.00	1	108.000	79.2
					1	?	1360.00	1	108.000	79.2
			23	0	0	59.00	59.00	1	4.000	92.7
			28	10	30	61.00	61.00	1	6.000	63.9
		8	1	12	45	106.00	106.00	1	9.000	74.1
			20	9	0	1502.00	1502.00	1	154.000	61.3
		9	1	11	0	517.00	517.00	1	58.000	56.0
	32	5	1	7	0	21.00	42.30	2	15.000	17.7
				8	20	21.30	42.30	2	15.000	17.7
i2	i4	i2	i2	i2	i2	f4.2	f4.2	i6	f6.3	f3.1

continued ...

Table 79. Continued.

year	station	month	day	hh	mm	s_vol	s_voltot	count	aesrngg	eff
81	32	5	17	7	0	237.20	237.20	1	18.000	82.9
		6	3	0	0	40.00	40.00	1	85.000	3.0
			4	0	0	45.00	45.00	1	35.000	8.1
			5	0	0	184.00	184.00	1	18.000	64.3
			8	0	0	37.00	37.00	1	51.000	4.6
			21	0	0	278.00	278.00	1	78.000	22.4
			27	20	10	312.00	312.00	1	121.000	16.2
		7	21	0	0	388.00	388.00	1	27.000	90.4
		8	12	7	40	41.00	41.00	1	7.000	36.8
		9	1	15	40	588.00	588.00	1	47.000	78.7
	34	5	2	18	30	43.50	43.50	1	3.000	91.2
			17	8	15	180.70	180.70	1	30.000	37.9
			18	22	0	38.80	38.80	1	45.000	5.4
		6	3	0	0	691.00	691.00	1	223.000	19.5
			7	0	0	507.00	507.00	1	147.000	21.7
			8	0	0	329.00	329.00	1	25.000	82.7
			18	0	0	82.00	82.00	1	21.000	24.6
		7	7	11	25	3286.00	3408.00	2	745.000	28.8
				19	25	122.00	3408.00	2	745.000	28.8
			23	0	0	680.00	680.00	1	66.000	64.8
	35	5	1	9	30	826.70	826.70	1	81.000	64.2
			17	9	30	58.00	58.00	1	35.000	10.4
		6	3	0	0	679.00	679.00	1	138.000	30.9
			6	0	0	57.00	57.00	1	12.000	29.9
			19	0	0	65.00	65.00	1	11.000	37.2
			21	0	0	478.00	833.00	2	161.000	32.5
					1	396.00	833.00	2	161.000	32.5
				1	0	396.00	833.00	2	161.000	32.5
		7	15	0	0	3475.00	3475.00	1	301.000	72.6
			21	0	0	460.00	649.00	2	42.000	97.2
				1	0	189.00	649.00	2	42.000	97.2
			23	0	0	709.00	709.00	1	100.000	44.6
		8	12	7	30	391.00	391.00	1	26.000	94.6
	41	5	1	7	5	259.20	259.20	1	32.000	50.9
			17	7	12	49.30	49.30	1	7.000	44.3
			18	18	2	599.80	599.80	1	112.000	33.7
		6	8	0	0	212.00	212.00	1	38.000	35.1
			18	0	0	280.00	280.00	1	39.000	45.1
			22	0	0	79.00	79.00	1	93.000	5.3
		7	6	17	11	187.00	187.00	1	20.000	58.8
			10	18	7	81.00	81.00	1	26.000	19.6
			13	0	0	1485.00	1485.00	1	394.000	23.7
			27	8	23	315.00	315.00	1	31.000	63.9
			28	12	16	207.00	207.00	1	26.000	50.1
	47	5	17	9	0	4.70	4.70	1	12.000	2.5
		6	3	0	0	805.00	805.00	1	155.000	32.7
i2	i4	i2	i2	i2	i2	f4.2	f4.2	i6	f6.3	f3.1

continued ...

Table 79. Continued.

year	station	month	day	hh	mm	s_vol	s_voltot	count	aesrngg	eff
81	47	6	4	0	0	479.00	479.00	1	56.000	53.8
			6	0	0	43.00	43.00	1	42.000	6.4
			8	0	0	460.00	460.00	1	112.000	25.8
		7	5	19	0	270.00	270.00	1	79.000	21.5
			7	16	0	746.00	746.00	1	446.000	10.5
			10	12	45	1046.00	1046.00	1	202.000	32.6
			14	0	0	88.00	88.00	1	12.000	46.1
			22	0	0	297.00	297.00	1	24.000	77.8
			23	0	0	100.00	100.00	1	41.000	15.3
		8	20	12	5	215.00	215.00	1	159.000	8.5
	51	5	17	6	45	85.20	125.80	1	2.000	395.5
					46	133.70	125.80	1	2.000	395.5
					47	158.50	125.80	1	2.000	395.5
		6	23	0	0	875.00	999.33	2	35.000	179.5
					1	427.00	999.33	2	35.000	179.5
					2	424.00	999.33	2	35.000	179.5
				2	0	424.00	999.33	2	35.000	179.5
			24	0	0	3124.00	3098.75	1	239.000	81.5
					1	3060.00	3098.75	1	239.000	81.5
					2	3105.00	3098.75	1	239.000	81.5
					3	3106.00	3098.75	1	239.000	81.5
	77	5	1	9	0	495.10	495.10	1	45.000	69.2
			17	7	35	27.10	27.10	1	18.000	9.5
		6	3	0	0	911.00	911.00	1	85.000	67.4
			6	0	0	92.00	92.00	1	27.000	21.4
			18	0	0	446.00	446.00	1	51.000	55.0
			21	0	0	548.00	548.00	1	46.000	74.9
			23	0	0	96.00	96.00	1	63.000	9.6
		7	7	12	50	1682.00	1682.00	1	325.000	32.5
			21	0	0	677.00	677.00	1	82.000	51.9
					1	?	677.00	1	82.000	51.9
			23	0	0	93.00	93.00	1	8.000	73.1
					1	?	93.00	1	8.000	73.1
			28	10	30	83.00	83.00	1	37.000	14.1
		8	12	9	20	61.00	61.00	1	20.000	19.2
	115	5	2	12	30	27.70	27.70	1	2.000	87.1
		6	6	0	0	1115.00	1115.00	1	82.000	85.5
			7	0	0	265.00	265.00	1	2.000	833.1
			14	0	0	107.00	107.00	1	10.000	67.3
			15	0	0	166.00	166.00	1	28.000	37.3
			18	0	0	324.00	324.00	1	48.000	42.4
			20	0	0	100.00	100.00	1	10.000	62.9
			21	0	0	166.00	166.00	1	31.000	33.7
		7	5	14	55	59.00	59.00	1	36.000	10.3
			7	9	15	2071.00	2159.00	2	338.000	40.2
				20	35	88.00	2159.00	2	338.000	40.2
i2	i4	i2	i2	i2	i2	f4.2	f4.2	i6	f6.3	f3.1

continued ...

Table 79. Continued.

year	station	month	day	hh	mm	s_vol	s_voltot	count	aesrngg	eff
81	115	7	7	20	36	?	2159.00	2	338.000	40.2
			8	18	25	10.00	10.00	1	2.000	31.4
			9	18	5	59.00	59.00	1	12.000	30.9
			10	7	5	316.00	316.00	1	46.000	43.2
			14	0	0	458.00	458.00	1	130.000	22.2
			23	12	55	29.00	29.00	1	9.000	20.3
		8	20	12	50	155.00	155.00	1	105.000	9.3
		9	20	0	30	1031.00	2058.00	2	103.000	125.6
				9	30	1027.00	2058.00	2	103.000	125.6
82	5	5	12	14	0	297.00	297.00	1	31.000	60.2
			15	15	0	792.00	792.00	1	55.000	90.5
					1	?	792.00	1	55.000	90.5
			19	8	0	356.00	356.00	1	21.000	106.6
			22	14	0	788.00	788.00	1	52.000	95.3
			26	14	0	96.00	96.00	1	38.000	15.9
			27	13	0	1240.00	1240.00	1	55.000	141.8
		6	4	21	0	183.00	183.00	1	9.000	127.9
		7	2	10	8	511.00	511.00	1	46.000	69.8
			4	14	0	550.00	550.00	1	58.000	59.6
			27	17	0	279.00	279.00	1	35.000	50.1
		8	3	21	0	1600.00	1600.00	1	67.000	150.2
			4	15	0	277.00	277.00	1	80.000	21.8
			6	8	0	1650.00	1650.00	1	127.000	81.7
					1	?	1650.00	1	127.000	81.7
			11	11	0	1500.00	1500.00	1	119.000	79.3
					1	?	1500.00	1	119.000	79.3
			14	9	0	343.00	343.00	1	74.000	29.1
			27	19	30	1230.00	1230.00	1	100.000	77.3
					31	?	1230.00	1	100.000	77.3
		9	9	17	0	1560.00	1560.00	1	120.000	81.7
					1	?	1560.00	1	120.000	81.7
	15	5	13	14	21	52.00	52.00	1	5.000	65.4
			14	17	51	94.00	94.00	1	46.000	12.8
			15	17	36	567.00	567.00	1	44.000	81.0
			16	14	40	160.00	160.00	1	48.000	21.0
			22	19	30	410.00	410.00	1	215.000	12.0
					31	?	410.00	1	215.000	12.0
			30	18	10	95.00	304.00	2	27.000	70.8
				21	20	209.00	304.00	2	27.000	70.8
		6	4	18	20	34.00	34.00	1	6.000	35.6
			9	21	0	43.00	43.00	1	4.000	67.6
			14	14	15	168.00	168.00	1	10.000	105.6
			30	12	50	483.00	1241.00	2	89.000	87.7
				18	40	758.00	1241.00	2	89.000	87.7
					41	?	1241.00	2	89.000	87.7
		7	12	15	55	193.00	193.00	1	12.000	101.1
i2	i4	i2	i2	i2	i2	f4.2	f4.2	i6	f6.3	f3.1

continued ...

Table 79. Continued.

year	station	month	day	hh	mm	s_vol	s_voltot	count	aesrngg	eff
82	15	7	18	14	10	115.00	115.00	1	72.000	10.0
			22	7	30	949.00	949.00	1	184.000	32.4
					31	?	949.00	1	184.000	32.4
			23	10	9	51.00	51.00	1	37.000	8.7
		8	2	8	15	113.00	113.00	1	39.000	18.2
			3	15	10	62.00	62.00	1	15.000	26.0
			6	7	45	62.00	62.00	1	41.000	9.5
			11	9	41	767.00	767.00	1	52.000	92.7
	28	5	5	7	30	495.00	495.00	1	115.000	27.1
					31	?	495.00	1	115.000	27.1
			16	13	50	172.00	172.00	1	14.000	77.2
		6	30	16	30	812.00	812.00	1	156.000	32.7
					31	?	812.00	1	156.000	32.7
			7	2	16	769.00	769.00	1	96.000	50.4
			4	8	0	80.00	187.00	2	32.000	36.7
				12	30	107.00	187.00	2	32.000	36.7
			15	13	45	22.00	696.00	2	144.000	30.4
				14	25	674.00	696.00	2	144.000	30.4
			19	12	40	158.00	252.00	2	44.000	36.0
				18	10	94.00	252.00	2	44.000	36.0
			22	12	30	379.00	555.00	2	90.000	38.8
				18	0	176.00	555.00	2	90.000	38.8
		8	2	15	0	763.00	763.00	1	83.000	57.8
					1	?	763.00	1	83.000	57.8
			3	9	10	126.00	890.00	3	88.000	63.6
				12	20	561.00	890.00	3	88.000	63.6
				19	40	203.00	890.00	3	88.000	63.6
			6	14	30	326.00	326.00	1	42.000	48.8
			11	7	45	169.00	1243.00	2	101.000	77.4
				9	35	1074.00	1243.00	2	101.000	77.4
					36	?	1243.00	2	101.000	77.4
			15	7	30	237.00	237.00	1	28.000	53.2
					31	?	237.00	1	28.000	53.2
			20	19	30	100.00	100.00	1	12.000	52.4
	29	5	19	10	0	79.00	79.00	1	39.000	12.7
			23	7	30	542.00	542.00	1	62.000	55.0
			30	21	0	26.00	26.00	1	32.000	5.1
		6	7	0	0	48.00	48.00	1	9.000	33.5
			12	15	10	740.00	740.00	1	120.000	38.8
			16	15	0	1708.00	1708.00	1	118.000	91.0
					1	?	1708.00	1	118.000	91.0
			7	2	19	0	865.00	1	101.000	53.9
			5	12	45	1770.00	1770.00	1	106.000	105.0
			22	11	10	429.00	429.00	1	93.000	29.0
			23	9	30	552.00	552.00	1	9.000	385.6
					31	?	552.00	1	9.000	385.6
i2	i4	i2	i2	i2	i2	f4.2	f4.2	i6	f6.3	f3.1

continued ...

Table 79. Continued.

year	station	month	day	hh	mm	s_vol	s_voltot	count	aesrngg	eff
82	29	8	11	9	0	125.00	125.00	1	18.000	43.7
			17	14	45	121.00	121.00	1	265.000	2.9
			27	19	30	147.00	147.00	1	78.000	11.8
			31	16	30	737.00	737.00	1	43.000	107.8
					31	?	737.00	1	43.000	107.8
		9	8	10	30	338.00	338.00	1	24.000	88.6
			9	93	0	557.00	557.00	1	170.000	20.6
	32	5	15	17	0	332.00	332.00	1	30.000	69.6
					1	?	332.00	1	30.000	69.6
		6	4	18	0	886.00	886.00	1	65.000	85.7
			20	8	0	616.00	616.00	1	36.000	107.6
		7	2	0	0	1880.00	1880.00	1	90.000	131.3
			18	13	30	1380.00	1380.00	1	145.000	59.8
			19	0	0	1905.00	1905.00	1	105.000	114.1
					1	?	1905.00	1	105.000	114.1
			23	6	30	1570.00	1570.00	1	50.000	197.4
		8	6	0	0	1590.00	1590.00	1	90.000	111.1
					1	?	1590.00	1	90.000	111.1
			11	10	10	488.00	488.00	1	75.000	40.9
	34	5	12	7	40	14.00	14.00	1	18.000	4.9
			13	8	15	41.00	41.00	1	4.000	64.4
			16	15	25	403.00	403.00	1	28.000	90.5
			17	17	30	125.00	125.00	1	11.000	71.5
			19	9	40	236.00	236.00	1	15.000	98.9
			23	8	30	574.00	574.00	1	45.000	80.2
		6	2	18	0	1322.00	1322.00	1	96.000	86.6
					1	?	1322.00	1	96.000	86.6
			7	22	0	601.00	601.00	1	35.000	108.0
					1	?	601.00	1	35.000	108.0
			11	22	10	38.00	38.00	1	4.000	59.7
			12	17	15	248.00	248.00	1	22.000	70.9
			13	15	45	76.00	76.00	1	8.000	59.7
			14	19	0	62.00	62.00	1	7.000	55.7
			16	11	55	2130.00	2130.00	1	147.000	91.1
		7	2	15	10	1200.00	1200.00	1	86.000	87.7
			3	16	35	222.00	222.00	1	23.000	60.7
			10	14	15	63.00	63.00	1	14.000	28.3
			11	17	0	31.00	31.00	1	4.000	48.7
			19	7	30	1680.00	1680.00	1	128.000	82.5
					31	?	1680.00	1	128.000	82.5
			22	13	15	2270.00	3910.00	2	375.000	65.6
					16	?	3910.00	2	375.000	65.6
			20	45	1640.00	3910.00	2	375.000	65.6	
			27	8	10	245.00	245.00	1	73.000	21.1
		8	4	8	0	383.00	595.00	2	44.000	85.0
					15	212.00	595.00	2	44.000	85.0
i2	i4	i2	i2	i2	i2	f4.2	f4.2	i6	f6.3	f3.1

continued ...



Table 79. Continued.

year	station	month	day	hh	mm	s_vol	s_voltot	count	aesrngg	eff
82	34	8	6	8	0	1082.00	1082.00	1	84.000	81.0
			11	10	50	477.00	477.00	1	39.000	76.9
			28	11	0	449.00	449.00	1	80.000	35.3
		9	2	19	45	131.00	131.00	1	13.000	63.4
			3	17	45	746.00	746.00	1	57.000	82.3
	35	5	4	17	0	328.00	328.00	1	28.000	73.7
					1	?	328.00	1	28.000	73.7
			23	10	20	156.00	156.00	1	16.000	61.3
					21	?	156.00	1	16.000	61.3
		6	9	15	0	12.00	106.00	2	16.000	41.7
					20	94.00	106.00	2	16.000	41.7
		7	12	18	0	33.00	33.00	1	51.000	4.1
			18	13	45	718.00	718.00	1	173.000	26.1
			22	14	30	1120.00	1120.00	1	172.000	40.9
					31	?	1120.00	1	172.000	40.9
			23	9	30	396.00	396.00	1	99.000	25.2
			27	14	0	545.00	545.00	1	53.000	64.7
		8	6	10	0	559.00	559.00	1	86.000	40.9
			11	12	0	549.00	549.00	1	48.000	71.9
			17	22	30	435.00	435.00	1	36.000	76.0
			28	8	30	41.00	41.00	1	72.000	3.6
		9	3	18	30	788.00	788.00	1	70.000	70.8
	41	5	11	21	0	60.00	60.00	1	15.000	25.2
			12	12	50	22.00	22.00	1	65.000	2.1
					51	?	22.00	1	65.000	2.1
			13	15	0	59.00	59.00	1	11.000	33.7
			14	21	45	74.00	74.00	1	27.000	17.2
			15	18	0	577.00	577.00	1	66.000	55.0
					1	?	577.00	1	66.000	55.0
			22	14	15	55.00	55.00	1	123.000	2.8
		6	11	0	0	323.00	323.00	1	25.000	81.2
			30	12	30	857.00	857.00	1	80.000	67.4
		7	13	14	15	106.00	106.00	1	10.000	66.6
			17	20	45	555.00	555.00	1	52.000	67.1
			18	12	25	296.00	296.00	1	69.000	27.0
			22	0	0	126.00	660.00	2	118.000	35.2
					19	534.00	660.00	2	118.000	35.2
			23	10	45	126.00	126.00	1	47.000	16.9
			25	15	30	297.00	297.00	1	34.000	54.9
		8	3	9	0	357.00	357.00	1	43.000	52.2
			4	11	30	673.00	673.00	1	115.000	36.8
					31	?	673.00	1	115.000	36.8
			6	0	0	128.00	128.00	1	20.000	40.2
			11	11	30	634.00	634.00	1	60.000	66.4
					31	?	634.00	1	60.000	66.4
			14	16	10	94.00	94.00	1	45.000	13.1
i2	i4	i2	i2	i2	i2	f4.2	f4.2	i6	f6.3	f3.1

continued ...

Table 79. Continued.

year	station	month	day	hh	mm	s_vol	s_voltot	count	aesrngg	eff
82	47	5	15	14	30	630.00	630.00	1	45.000	88.0
			16	16	0	263.00	263.00	1	25.000	66.1
			19	7	0	872.00	872.00	1	62.000	88.4
					1	?	872.00	1	62.000	88.4
			22	20	30	314.00	314.00	1	20.000	98.7
			25	23	0	229.00	229.00	1	17.000	84.7
			30	21	0	177.00	177.00	1	12.000	92.7
		6	4	19	0	516.00	516.00	1	38.000	85.4
			5	9	30	100.00	100.00	1	5.000	125.8
			7	20	0	458.00	458.00	1	30.000	96.0
			9	16	0	378.00	378.00	1	27.000	88.0
			16	18	0	140.00	140.00	1	7.000	125.8
			30	13	20	1100.00	1323.00	2	76.000	109.5
				17	0	223.00	1323.00	2	76.000	109.5
		7	2	15	0	550.00	550.00	1	45.000	76.8
			4	8	0	429.00	429.00	1	19.000	142.0
			11	15	0	420.00	420.00	1	43.000	61.4
			12	12	0	94.00	94.00	1	7.000	84.4
			18	22	0	949.00	949.00	1	151.000	39.5
					1	?	949.00	1	151.000	39.5
			19	7	0	1565.00	1565.00	1	110.000	89.5
					1	?	1565.00	1	110.000	89.5
			22	12	0	783.00	783.00	1	197.000	25.0
		8	4	7	0	831.00	831.00	1	7.000	746.4
			6	7	0	1470.00	2019.00	2	154.000	82.4
					1	?	2019.00	2	154.000	82.4
				15	0	549.00	2019.00	2	154.000	82.4
			11	10	0	1500.00	1500.00	1	110.000	85.7
					1	?	1500.00	1	110.000	85.7
			14	16	0	559.00	559.00	1	38.000	92.5
			22	14	30	324.00	324.00	1	25.000	81.5
			27	19	0	781.00	781.00	1	58.000	84.7
			28	8	0	186.00	186.00	1	24.000	48.7
			31	10	45	73.00	73.00	1	5.000	91.8
	115	5	22	14	45	966.00	966.00	1	137.000	44.3
			24	14	30	65.00	65.00	1	5.000	81.7
			26	11	35	186.00	186.00	1	20.000	58.5
		6	4	19	50	1428.00	1428.00	1	109.000	82.4
					51	?	1428.00	1	109.000	82.4
			16	0	0	605.00	605.00	1	79.000	48.2
			30	12	0	830.00	830.00	1	60.000	87.0
		7	2	0	0	392.00	392.00	1	105.000	23.5
			18	13	10	880.00	880.00	1	76.000	72.8
			22	7	15	2530.00	2530.00	1	269.000	59.1
		8	1	8	30	2750.00	2750.00	1	120.000	144.1
					31	?	2750.00	1	120.000	144.1
i2	i4	i2	i2	i2	i2	f4.2	f4.2	i6	f6.3	f3.1

continued ...

Table 79. Continued.

year	station	month	day	hh	mm	s_vol	s_voltot	count	aesrngg	eff			
82	115	8	5	0	0	1050.00	1050.00	1	53.000	124.6			
			11	8	50	379.00	379.00	1	95.000	25.1			
			21	20	0	145.00	145.00	1	13.000	70.1			
			22	17	50	512.00	512.00	1	53.000	60.7			
			27	13	30	171.00	171.00	1	55.000	19.5			
			31	0	0	848.00	848.00	1	69.000	77.3			
							1	?	848.00	1	69.000	77.3	
			9	9	0	0	439.00	439.00	1	147.000	18.8		
84	5	6	3	9	3	30.00	265.00	3	28.000	59.5			
				12	51	110.00	265.00	3	28.000	59.5			
				15	45	125.00	265.00	3	28.000	59.5			
			5	22	0	80.00	80.00	1	9.000	55.9			
			13	20	44	1230.00	1230.00	1	88.000	87.9			
			16	21	20	1260.00	1260.00	1	84.000	94.3			
			17	7	50	280.00	1500.00	2	127.000	74.3			
				21	15	1220.00	1500.00	2	127.000	74.3			
			19	17	20	340.00	1350.00	2	101.000	84.0			
				23	10	1010.00	1350.00	2	101.000	84.0			
			20	12	25	1010.00	1010.00	1	86.000	73.8			
			26	23	10	300.00	300.00	1	14.000	134.7			
			29	20	15	220.00	220.00	1	19.000	72.8			
				30	10	10	440.00	440.00	1	36.000	76.8		
				6	6	5	22	50	200.00	200.00	1	14.000	89.8
						6	15	45	78.00	308.00	2	20.000	96.8
						17	30		230.00	308.00	2	20.000	96.8
						17	8	10	30.00	30.00	1	20.000	9.4
						20	0	30	1280.00	2540.00	3	88.000	181.5
							10	35	1190.00	2540.00	3	88.000	181.5
							18	37	70.00	2540.00	3	88.000	181.5
						21	15	2	55.00	55.00	1	17.000	20.3
						27	4	35	350.00	350.00	1	9.000	244.5
			29	6	30	500.00	660.00	2	43.000	96.5			
				19	52	160.00	660.00	2	43.000	96.5			
	15	6	17	0	0	590.00	590.00	1	60.000	61.8			
	28	6	1	0	0	?	1242.00	2	277.000	28.2			
						1	?	1242.00	2	277.000	28.2		
						1	0	?	1242.00	2	277.000	28.2	
							1	?	1242.00	2	277.000	28.2	
						9	0	1210.00	1242.00	2	277.000	28.2	
						20	0	32.00	1242.00	2	277.000	28.2	
					19	12	45	1650.00	1650.00	1	289.000	35.9	
					30	20	0	150.00	150.00	1	77.000	12.2	
	29	6	2	7	45	53.00	83.00	2	18.000	29.0			
					12	45	30.00	83.00	2	18.000	29.0		
					16	16	28	700.00	700.00	1	50.000	88.0	
					19	22	40	920.00	920.00	1	199.000	29.1	
i2	i4	i2	i2	i2	i2	f4.2	f4.2	i6	f6.3	f3.1			

continued ...

Table 79. Continued.

year	station	month	day	hh	mm	s_val	s_valtot	count	aesrngg	eff	
84	32	6	1	0	0	?	1660.00	1	114.000	91.6	
					1	?	1660.00	1	114.000	91.6	
					1	0	?	1660.00	1	114.000	91.6
					1	?	1660.00	1	114.000	91.6	
					2	0	?	1660.00	1	114.000	91.6
					1	?	1660.00	1	114.000	91.6	
					11	54	1660.00	1	114.000	91.6	
				2	13	37	220.00	1	24.000	57.6	
				5	10	32	15.00	2	38.000	78.6	
					20	11	460.00	2	38.000	78.6	
				16	20	35	1370.00	1	90.000	95.7	
				17	16	25	88.00	1	16.000	34.6	
				19	17	15	1020.00	1	74.000	86.7	
				20	12	42	890.00	1	90.000	62.2	
				30	15	28	330.00	1	28.000	74.1	
	34	6	1	0	0	?	700.00	2	244.000	18.0	
					1	?	700.00	2	244.000	18.0	
					1	0	?	700.00	2	244.000	18.0
					1	?	700.00	2	244.000	18.0	
					2	0	?	700.00	2	244.000	18.0
					1	?	700.00	2	244.000	18.0	
					7	45	240.00	2	244.000	18.0	
					17	45	460.00	2	244.000	18.0	
				2	7	30	650.00	1	68.000	60.1	
						45	650.00	1	68.000	60.1	
				3	12	25	600.00	1	46.000	82.0	
				16	21	0	1100.00	1	136.000	50.9	
				17	7	30	400.00	1	136.000	34.7	
							1100.00	1	136.000	34.7	
				19	7	30	1200.00	1	92.000	82.0	
				20	14	0	50.00	1	6.000	52.4	
				24	13	30	105.00	1	10.000	66.0	
				27	8	0	280.00	1	22.000	80.0	
				29	11	0	1240.00	1	82.000	95.1	
	35	6	17	7	30	90.00	90.00	1	79.000	7.2	
				25	11	0	250.00	1	16.000	98.2	
				27	8	30	380.00	1	24.000	99.6	
	41	6	13	20	10	154.00	154.00	1	15.000	64.6	
				16	12	5	360.00	2	134.000	77.0	
					22	5	1280.00	2	134.000	77.0	
				19	14	0	700.00	2	170.000	85.1	
					23	10	1600.00	2	170.000	85.1	
				20	7	45	1050.00	3	144.000	125.1	
							1280.00	3	144.000	125.1	
					8	45	1050.00	3	144.000	125.1	
					13	35	650.00	3	144.000	125.1	
i2	i4	i2	i2	i2	i2	f4.2	f4.2	i6	f6.3	f3.1	

continued ...

Table 79. Concluded.

year	station	month	day	hh	mm	s_vol	s_voltot	count	aesrngg	eff
84	41	6	24	13	20	270.00	270.00	1	23.000	73.8
			28	23	25	1300.00	1300.00	1	96.000	85.1
			29	19	45	530.00	530.00	1	38.000	87.7
			30	8	35	800.00	800.00	1	48.000	104.8
	47	5	31	21	0	500.00	500.00	1	195.000	16.1
		6	1	0	0	1310.00	2840.00	2	398.000	44.9
						?	2840.00	2	398.000	44.9
					1	?	2840.00	2	398.000	44.9
				1	0	?	2840.00	2	398.000	44.9
					1	?	2840.00	2	398.000	44.9
				2	0	?	2840.00	2	398.000	44.9
					1	?	2840.00	2	398.000	44.9
				8	0	1530.00	2840.00	2	398.000	44.9
			2	9	10	530.00	1060.00	2	54.000	123.4
				15	30	530.00	1060.00	2	54.000	123.4
			17	10	10	95.00	153.00	2	14.000	68.7
				17	15	58.00	153.00	2	14.000	68.7
	77	6	3	13	1	150.00	150.00	1	32.000	29.5
			17	7	30	1070.00	2820.00	3	138.000	128.5
				12	30	1070.00	2820.00	3	138.000	128.5
				13	0	680.00	2820.00	3	138.000	128.5
			19	15	45	250.00	250.00	1	74.000	21.2
			24	20	30	42.00	42.00	1	4.000	66.0
			25	10	33	1010.00	1010.00	1	68.000	93.4
	115	5	31	3	0	3050.00	6100.00	2	550.000	69.7
				22	0	3050.00	6100.00	2	550.000	69.7
		6	1	0	0	?	3155.00	3	306.000	64.8
					1	?	3155.00	3	306.000	64.8
				1	0	?	3155.00	3	306.000	64.8
					1	?	3155.00	3	306.000	64.8
				2	0	?	3155.00	3	306.000	64.8
					1	?	3155.00	3	306.000	64.8
				3	0	?	3155.00	3	306.000	64.8
					1	?	3155.00	3	306.000	64.8
				4	0	?	3155.00	3	306.000	64.8
					1	?	3155.00	3	306.000	64.8
				8	25	1475.00	3155.00	3	306.000	64.8
				13	45	1500.00	3155.00	3	306.000	64.8
				22	0	180.00	3155.00	3	306.000	64.8
			5	19	16	350.00	350.00	1	28.000	78.6
			16	17	18	1100.00	1100.00	1	90.000	76.8
			19	11	55	330.00	530.00	2	170.000	19.6
				21	35	200.00	530.00	2	170.000	19.6
			20	12	30	610.00	610.00	1	42.000	91.3
			26	23	0	280.00	280.00	1	28.000	62.9
			30	8	20	450.00	450.00	1	36.000	78.6
i2	i4	i2	i2	i2	i2	f4.2	f4.2	i6	f6.3	f3.1

## 8.14 CO-LOCATED SAMPLING

The following are 1:1 plots of 1983 co-located sampling data for the following parameters:  $\text{NH}_4^+$ , ( $\text{SO}_4^{2-} - \text{S}$ ),  $\text{NO}_3^-$ ,  $\text{Cl}^-$ ,  $\text{Na}^+$ ,  $\text{Ca}^{2+}$ ,  $\text{Mg}^{2+}$ , pH, and specific conductivity.

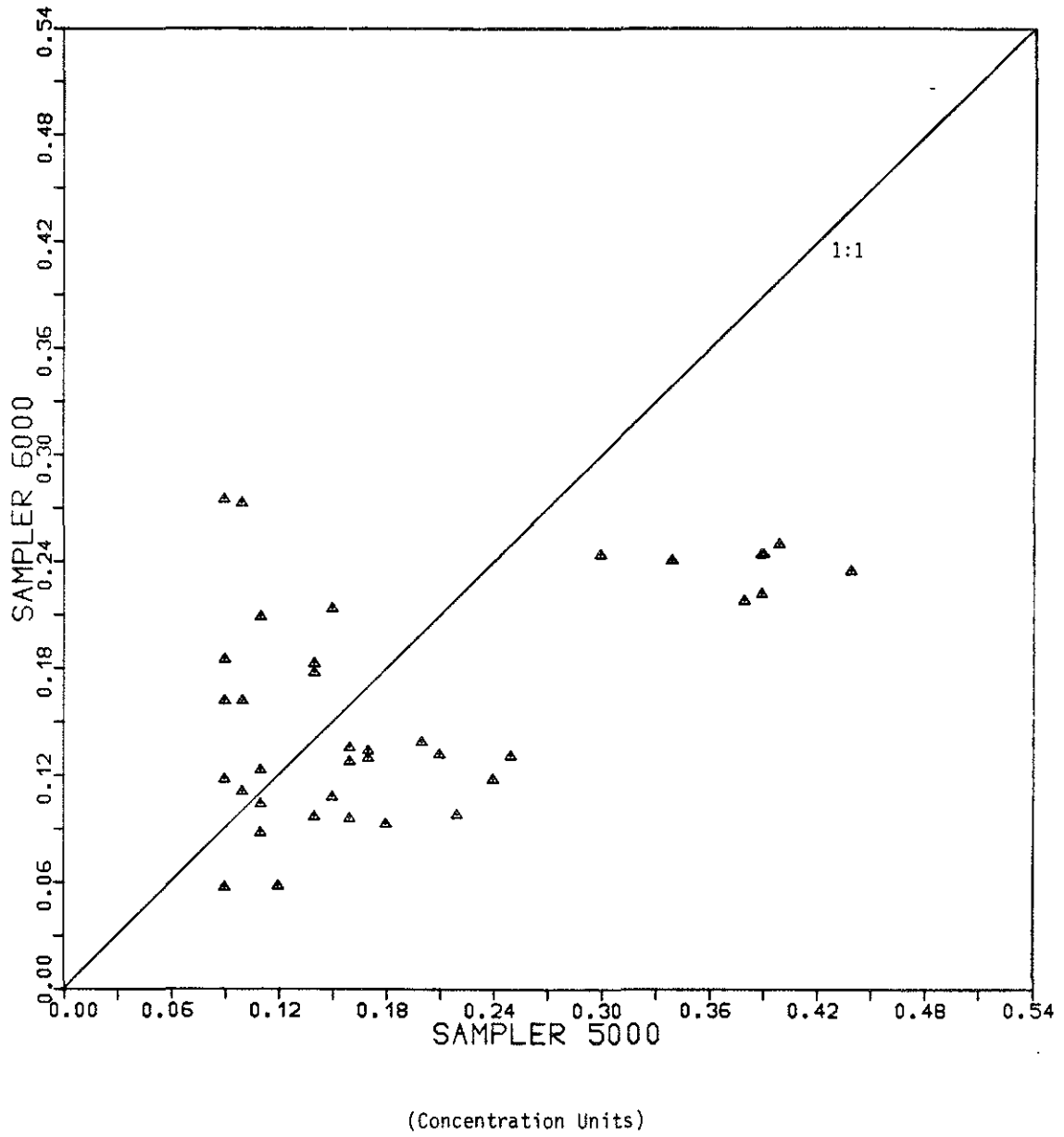

Figure 61. Plot of 1983 co-located sampling data for  $\text{NH}_4^+$ .

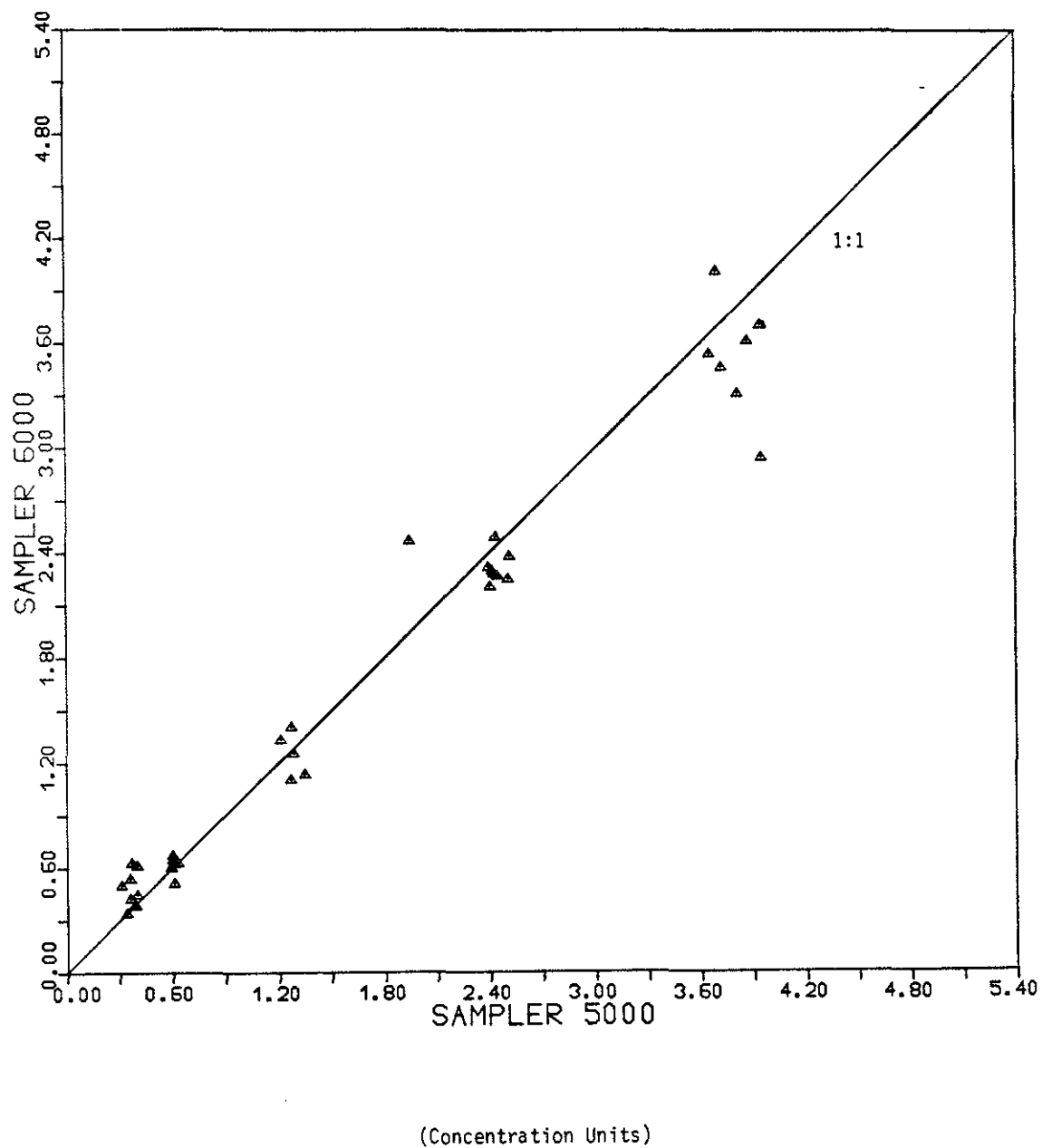

Figure 62. Plot of 1983 co-located sampling data for  $[\text{SO}_4^{2-} - \text{S}]$ .



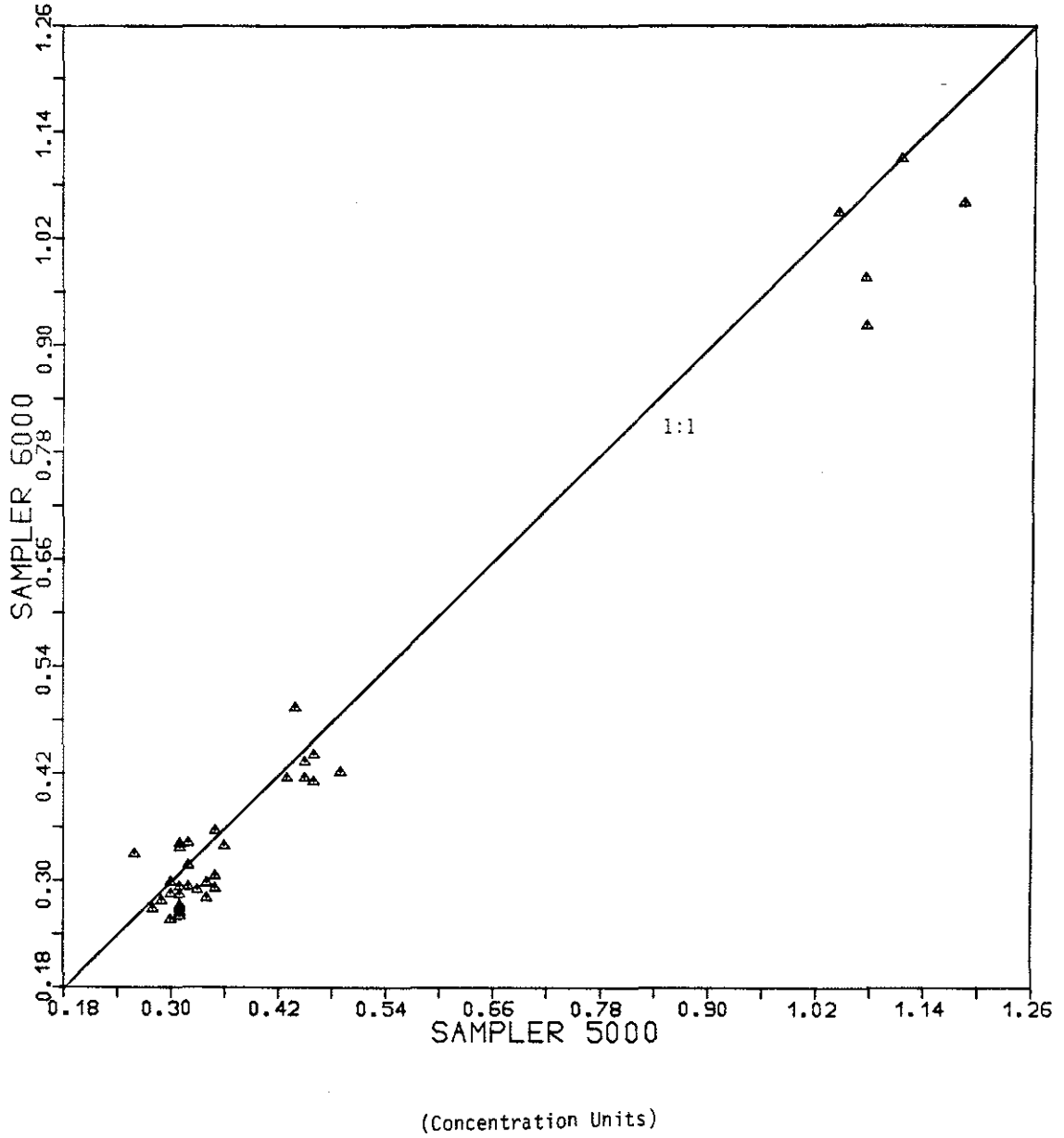

Figure 63. Plot of 1983 co-located sampling data for  $\text{NO}_3^-$ .

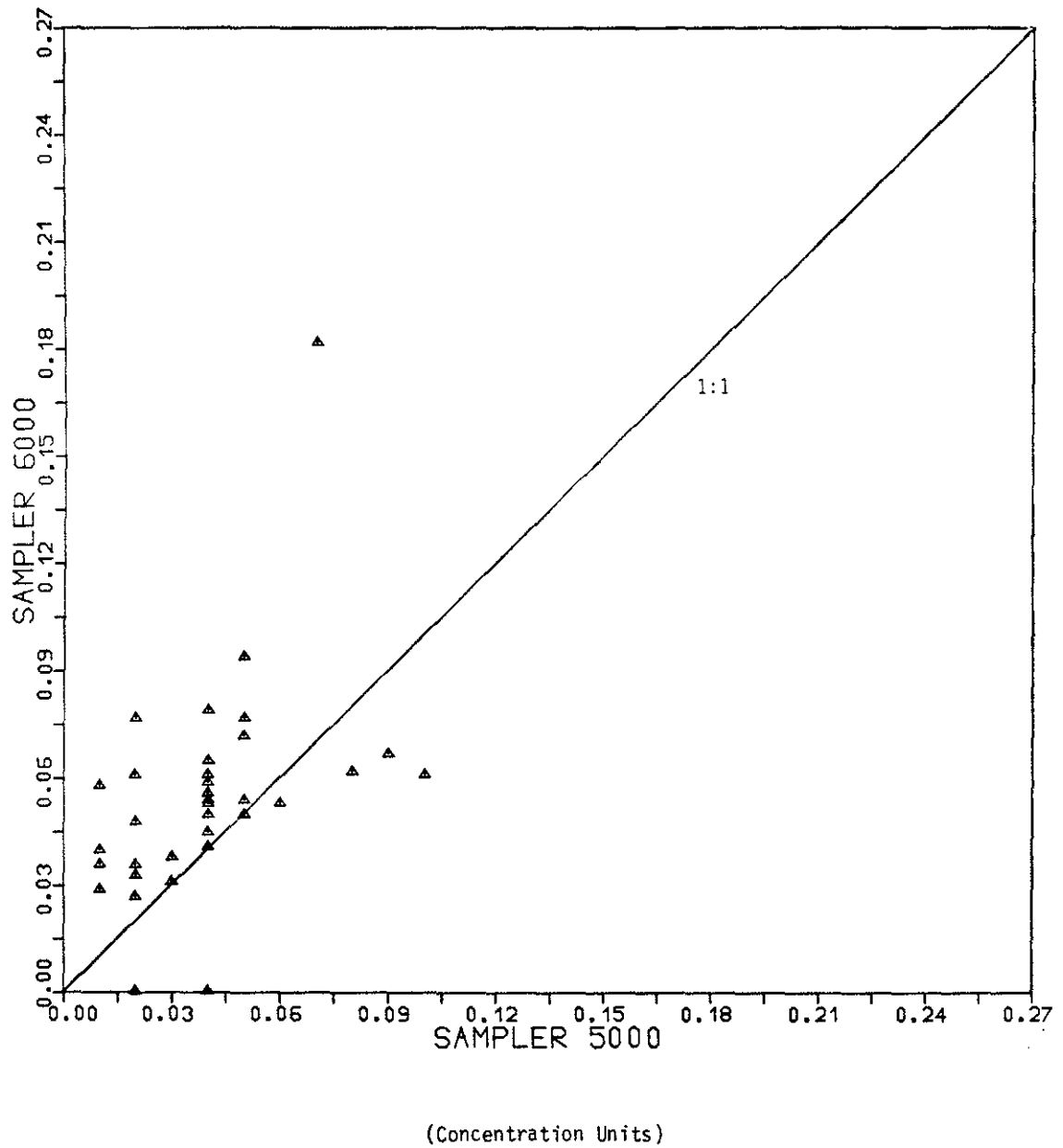

Figure 64. Plot of 1983 co-located sampling data for  $\text{Cl}^-$ .

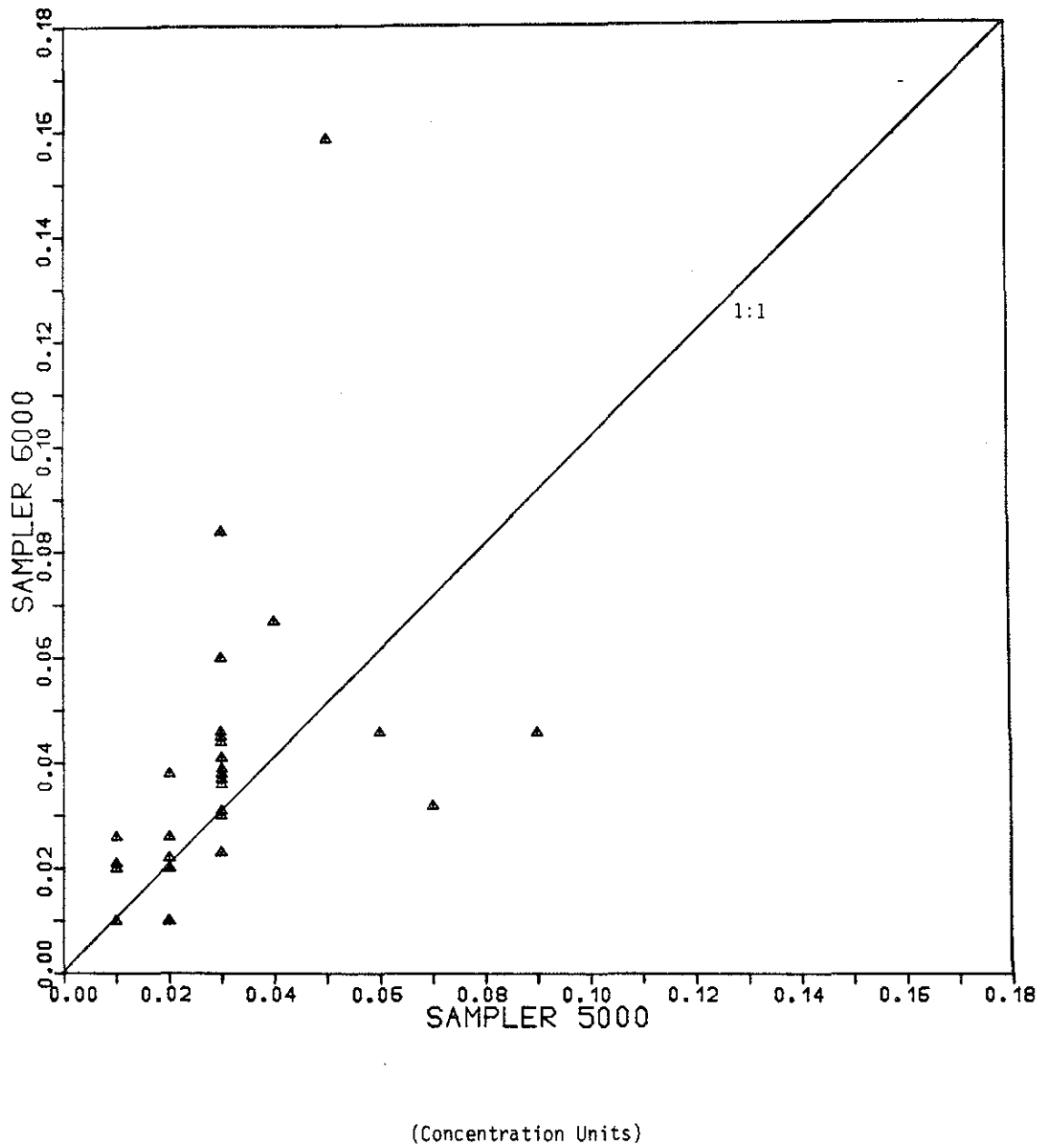

Figure 65. Plot of 1983 co-located sampling data for Na<sup>+</sup>.

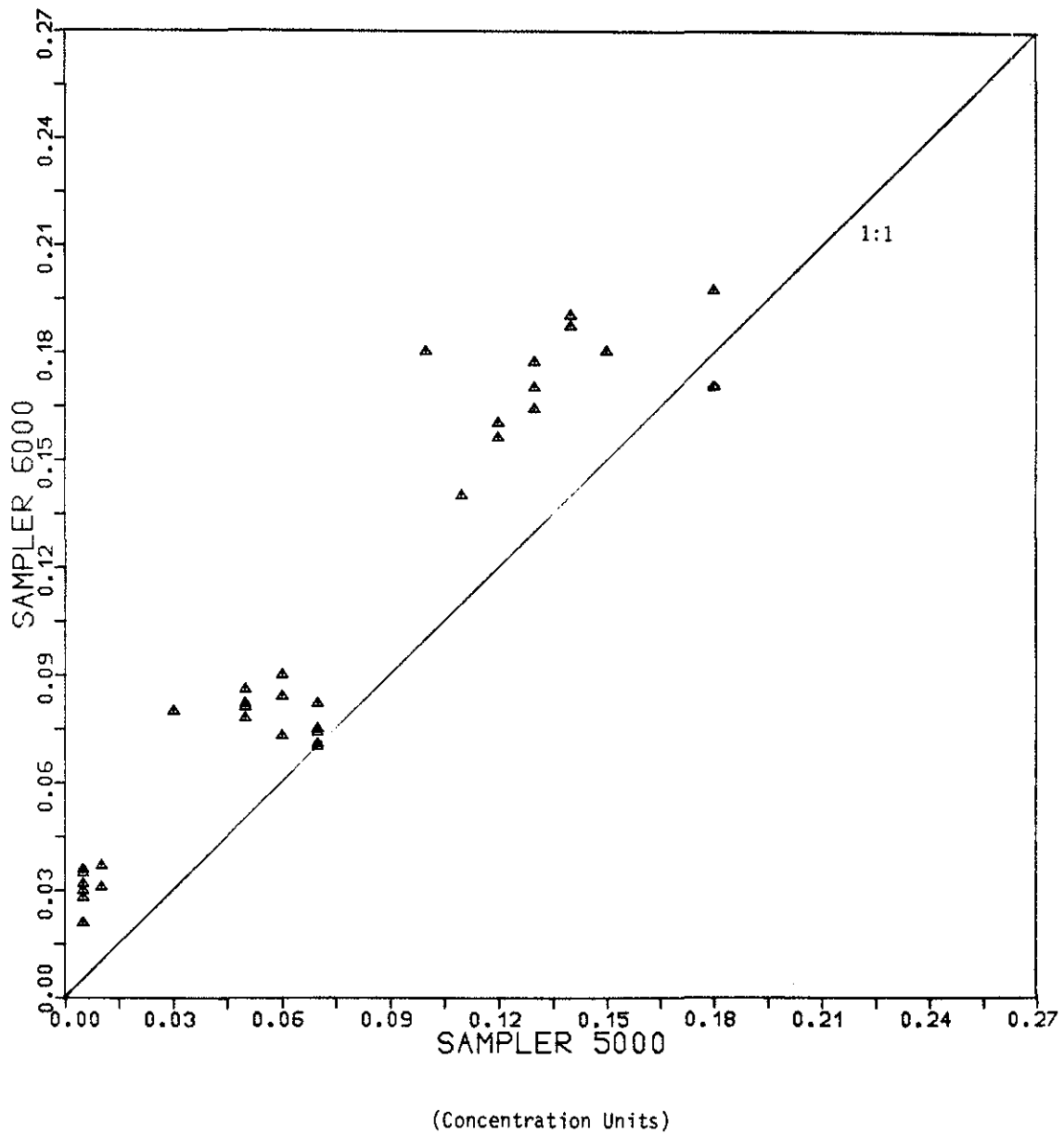

Figure 66. Plot of 1983 co-located sampling data for  $\text{Ca}^{2+}$ .

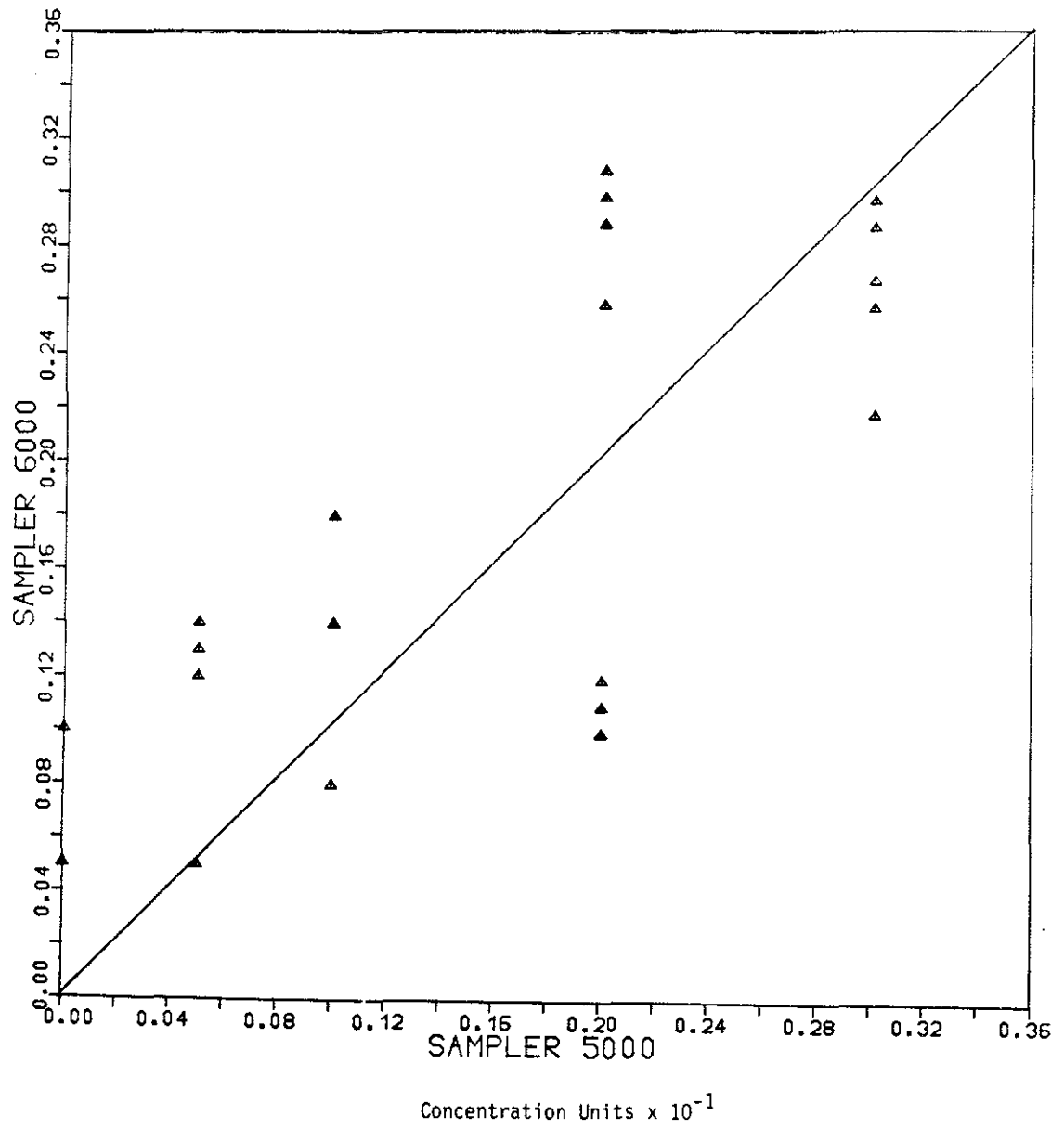

Figure 67. Plot of 1983 co-located sampling data for  $Mg^{2+}$ .

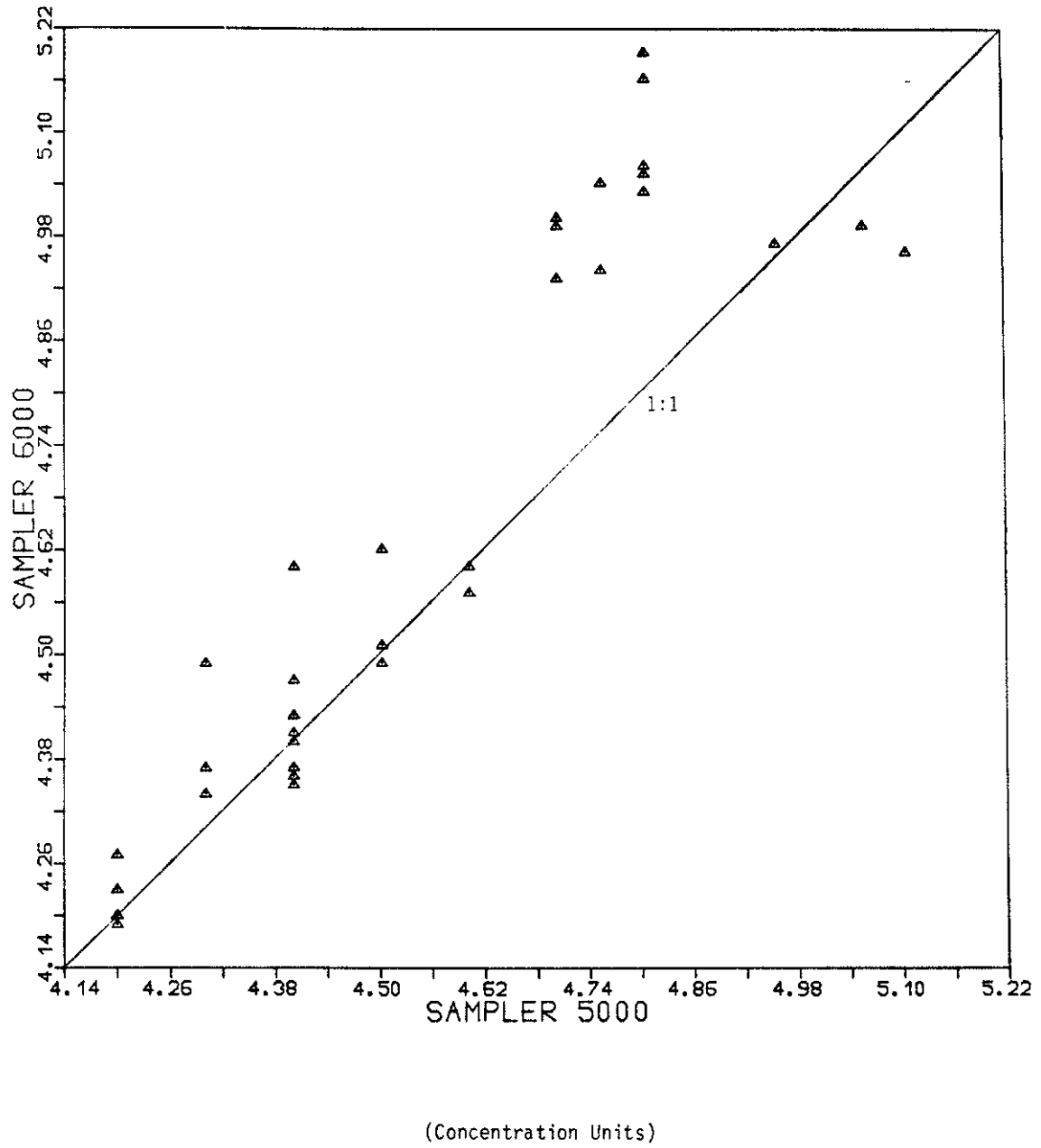

Figure 68. Plot of 1983 co-located sampling data for pH.

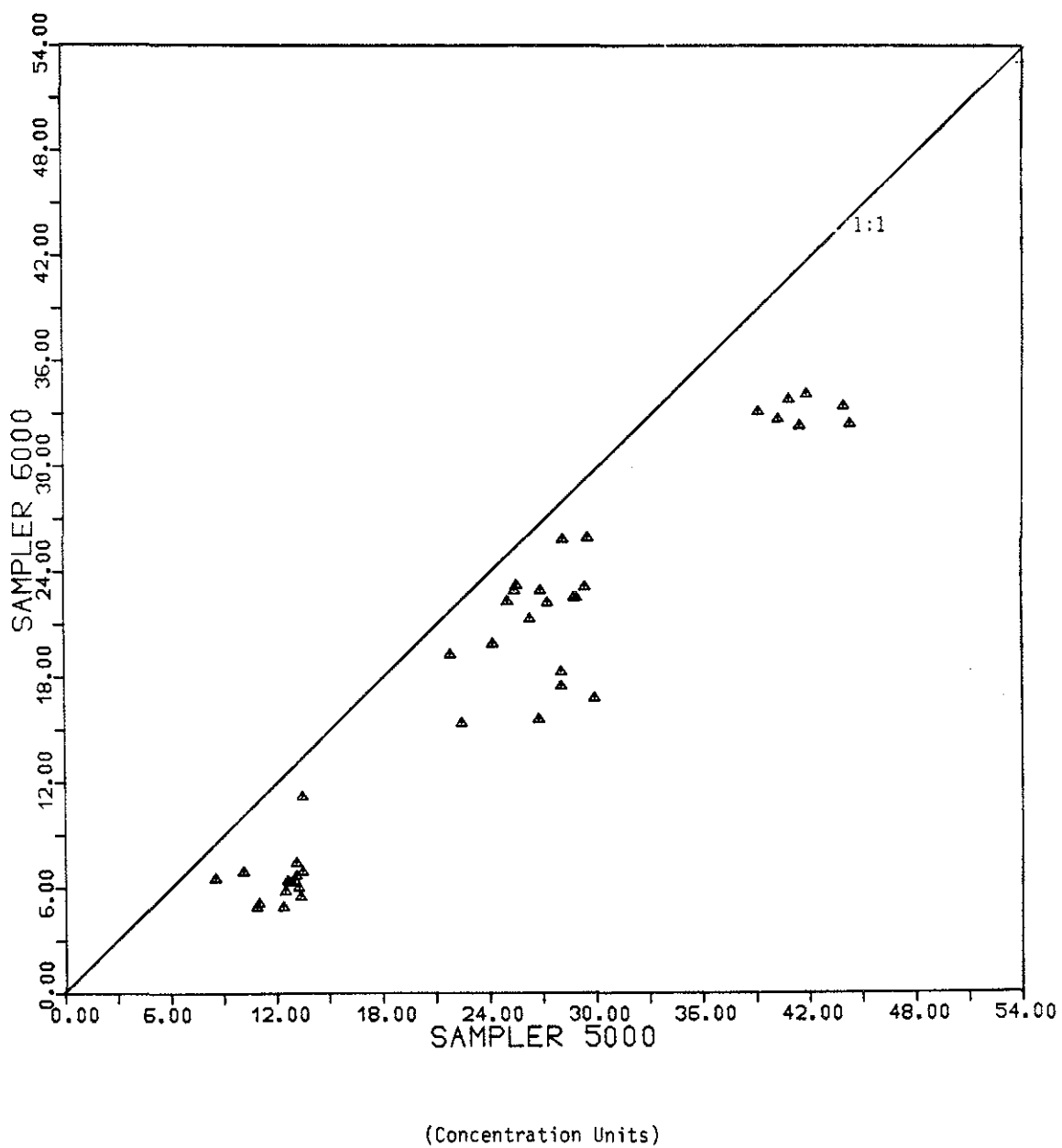

Figure 69. Plot of 1983 co-located sampling data for specific conductivity.

## 8.15 A SUMMARY OF SYNOPTIC WEATHER ANALYSIS FOR SELECTED WET DEPOSITION PERIODS

### 8.15.1 31 July to 2 August 1979

A low pressure cell (central sea-level pressure 100.8 kPa) located at the western end of Great Slave Lake on the morning of 31 July 1979 moved southeastward to just west of Lake Athabasca and deepened slightly (100.5 kPa) by the morning of 1 August. A frontal band from this low stretched southeastward as a cold front to Lac La Rouge, Saskatchewan and then as a warm front southeastward. On the 2nd, a low pressure cell (101.0 kPa) covered northern Alberta with a warm front extending from it along the Yukon border southeastward to the central Saskatchewan-Manitoba border.

Maximum precipitation in the AOSERP network occurred at the two most western sites (>10 mm) on the 31st and was generally moderate to heavy (3 to 30 mm) across the region on both the 1st and 2nd.

Elevated ion concentrations (those in the upper 15th percentile) were found at Keane ( $\text{Na}^+$ ) on the 31st, at Richardson ( $\text{Na}^+$ ,  $\text{K}^+$ ), Buckton ( $\text{Na}^+$ ,  $\text{K}^+$ ), Jean Lake ( $\text{Cl}^-$ ,  $\text{Na}^+$ ,  $\text{Mg}^{2+}$ ), Bitumount ( $\text{Na}^+$ ,  $\text{NH}_4^+$ ), and Muskeg ( $\text{Na}^+$ ,  $\text{K}^+$ ,  $\text{NH}_4^+$ ,  $\text{Ca}^{2+}$ ,  $\text{Cl}^-$ ) on the 1st, and Jean Lake ( $\text{Mg}^{2+}$ ,  $\text{Na}^+$ ,  $\text{Cl}^-$ ) and Muskeg ( $\text{Na}^+$ ) on the 2nd. From the available data, no specific source can be determined.

### 8.15.2 17 May 1981

A weak low pressure gradient across the West predominated the synoptic situation on 17 May 1981. A high pressure cell was located in northwestern Ontario and pressure decreased to the west. A small low pressure cell located in the southeastern Yukon moved slowly northeastward to Great Slave Lake by the morning of the 18th. Airflow was generally south to southeast over the West. Precipitation fell across the U.S. plains and the Canadian prairies from Nebraska northwestward.

Rainfall in the AOSERP region was light (<4 mm). Stations reporting elevated concentrations were Richardson ( $\text{NH}_4^+$ ,  $\text{NO}_3^-$ ,  $\text{SO}_4^{2-}$ ),



Buckton ( $\text{NH}_4^+$ ), Birch Mountain ( $\text{NO}_3^-$ ,  $\text{SO}_4^{2-}$ ), Legend ( $\text{NH}_4^+$ ,  $\text{Mg}^{2+}$ ,  $\text{Ca}^{2+}$ ,  $\text{NO}_3^-$ ,  $\text{SO}_4^{2-}$ , pH), Bitumount ( $\text{NH}_4^+$ ,  $\text{Mg}^{2+}$ ,  $\text{Ca}^{2+}$ ,  $\text{NO}_3^-$ ,  $\text{SO}_4^{2-}$ , pH), and Johnson Lake ( $\text{NH}_4^+$ ,  $\text{NO}_3^-$ ). Because of the light pressure gradient resulting in southerly winds, Suncor and Syncrude were possible sources for these elevated concentrations of ions.

#### 8.15.3 5 July 1981

A weak high pressure cell (101.3 kPa) was located over east-central Alberta on the morning of 5 July 1981. During the day, a low pressure cell developed over southeastern British Columbia and moved in a southeastward arc to the southern Saskatchewan border by early on the 6th (central pressure 100.0 kPa). Rainfall over the AOSERP network was scattered, likely falling as showers. A weak south-southeasterly flow developed on the 5th.

Although precipitation was scattered and generally light (only one station reported rain in excess of 7 mm), four sites reported elevated concentrations: Muskeg ( $\text{NH}_4^+$ ,  $\text{NO}_3^-$ ,  $\text{SO}_4^{2-}$ ,  $\text{Cl}^-$ , pH), Mildred Lake ( $\text{K}^+$ ,  $\text{NH}_4^+$ ,  $\text{Ca}^{2+}$ ,  $\text{NO}_3^-$ ,  $\text{SO}_4^{2-}$ , pH), Ells (pH), and Thickwood ( $\text{Na}^+$ ,  $\text{NH}_4^+$ ,  $\text{Mg}^{2+}$ ,  $\text{NO}_3^-$ ,  $\text{SO}_4^{2-}$ ,  $\text{Cl}^-$ , pH). Two of the sites are located to the north of the oil sands sources (Suncor and Syncrude) and one is to the south. Air circulations under convective shower conditions are complex and it is possible that each of the sites was affected by emissions from Suncor and Syncrude sources.

#### 8.15.4 12 August 1981

A cold front extended from a low (100.4 kPa) located north of Great Slave Lake southward through western Lake Athabasca and then curved westward to the southern Alberta-British Columbia border on the morning of 12 August 1981. By the morning of the 13th, the low was in the northwestern corner of Manitoba.

Precipitation was light (<3 mm) over the AOSERP network. Four stations reported elevated concentrations: Keane ( $\text{Ca}^{2+}$ ,  $\text{NO}_3^-$ ,  $\text{SO}_4^{2-}$ , pH), Richardson ( $\text{Mg}^{2+}$ ,  $\text{NO}_3^-$ ,  $\text{SO}_4^{2-}$ , pH), Bitumount (pH), and Thickwood ( $\text{Na}^+$ ,  $\text{K}^+$ ,  $\text{NH}_4^+$ ,  $\text{Mg}^{2+}$ ,  $\text{Ca}^{2+}$ ,  $\text{NO}_3^-$ ,  $\text{SO}_4^{2-}$ , pH). Fort McMurray

Airport reported southeast winds at 5 knots and smoke at 0500 MST. Upward motions at the cold frontal zone could have incorporated local emissions into the precipitation falling at these sites.

#### 8.15.5 1 September 1981

A developing low pressure system (99.6 kPa) moved out of the Yukon to northwestern Alberta on 1 September 1981 and continued southeastward to central Saskatchewan 24 hours later. This low moved along a stationary front stretching from the southeast corner of the Yukon southeastward to Lake Winnipeg. A second low (100.0 kPa) remained over northern British Columbia with an occluded front southward towards the Washington-Oregon coast.

Precipitation was variable, ranging from a trace to 13.8 mm across the network. Stations reporting elevated concentrations were Birch Mountain ( $\text{NH}_4^+$ , pH), Johnson Lake ( $\text{NH}_4^+$ ,  $\text{NO}_3^-$ ,  $\text{SO}_4^{2-}$ , pH), Ells ( $\text{NH}_4^+$ ), Thickwood ( $\text{NH}_4^+$ ), and Gordon Lake ( $\text{NH}_4^+$ ,  $\text{NO}_3^-$ ).

#### 8.15.6 14-17 May 1982

A stationary front curved from a northwest-southeast line parallel to the Rocky Mountains to southern Saskatchewan and then northeastward to north of James Bay on 14 May 1982. A high pressure cell (102.8 kPa) was located along the northern Saskatchewan-Manitoba border on the 14th and built to 103.6 kPa on the 15th. This high then moved eastward to the Hudson Bay shore. On the 16th, a very weak low (102.0 kPa) formed over Lake Athabasca but dissipated on the 17th. A north-south cold front over central British Columbia on the 17th moved eastward to western Alberta on the morning of the 18th. Sea-level pressure over northeastern Alberta ranged from 102.0 to 102.4 kPa over the four-day period.

Daily precipitation totals were low (<10 mm) and rainfall was scattered. Daily rainfall across the network ranged from 0 to 4.6 mm on the 14th, a trace to 8.1 mm on the 15th, a trace to 4.8 mm on the 16th, and a trace to 1.9 mm on the 17th.

A number of stations reported elevated concentrations. On the 14th, Legend ( $\text{NH}_4^+$ ,  $\text{SO}_4^{2-}$ , pH) and Ells ( $\text{Na}^+$ ,  $\text{NO}_3^-$ , pH) measured

high concentrations. Winds at Fort McMurray were east-southeast, thus these two sites were downwind of the Suncor and Syncrude emissions.

Six stations reported elevated concentrations on the 15th: Legend ( $\text{NH}_4^+$ ,  $\text{NO}_3^-$ ,  $\text{SO}_4^{2-}$ , pH), Ells ( $\text{NH}_4^+$ ,  $\text{NO}_3^-$ ,  $\text{SO}_4^{2-}$ , pH), Birch Mountain ( $\text{NH}_4^+$ ,  $\text{NO}_3^-$ ), Bitumount ( $\text{Na}^+$ ,  $\text{NH}_4^+$ ,  $\text{Ca}^{2+}$ ,  $\text{NO}_3^-$ ,  $\text{SO}_4^{2-}$ ), Muskeg ( $\text{NH}_4^+$ ,  $\text{NO}_3^-$ ) and Stony Mountain ( $\text{NH}_4^+$ ,  $\text{Ca}^{2+}$ ,  $\text{NO}_3^-$ ). Fort McMurray winds were south-southeast on the 15th and therefore all stations except Stony Mountain were downwind of the local sources.

On the 16th, Keane ( $\text{NH}_4^+$ ,  $\text{Mg}^{2+}$ ,  $\text{Ca}^{2+}$ ,  $\text{NO}_3^-$ ,  $\text{SO}_4^{2-}$ ), Johnson Lake ( $\text{NH}_4^+$ ,  $\text{Na}^+$ ,  $\text{Mg}^{2+}$ ,  $\text{Ca}^{2+}$ ,  $\text{NO}_3^-$ ,  $\text{SO}_4^{2-}$ ), Muskeg ( $\text{NH}_4^+$ ,  $\text{Ca}^{2+}$ ,  $\text{NO}_3^-$ ,  $\text{SO}_4^{2-}$ ), Ells ( $\text{Na}^+$ ,  $\text{K}^+$ ,  $\text{NO}_3^-$ ,  $\text{SO}_4^{2-}$ ), and Grande ( $\text{NH}_4^+$ ,  $\text{Mg}^{2+}$ ,  $\text{Ca}^{2+}$ ,  $\text{NO}_3^-$ ,  $\text{SO}_4^{2-}$ ) reported elevated concentrations. Winds at Fort McMurray on the morning of the 16th were southerly and shifted to the north by early morning of the 17th. The local emissions (Suncor and Syncrude) therefore may be the source of these ions.

On the 17th, rainfall was light and scattered. Two sites reported elevated concentrations: Mildred Lake ( $\text{Ca}^{2+}$ ,  $\text{NO}_3^-$ ) and Grande ( $\text{Na}^+$ ,  $\text{NH}_4^+$ ,  $\text{NO}_3^-$ ). The morning Fort McMurray wind was from the north and the Grande site was downwind of the two oil sands sources. Mildred Lake is located north of these sources but within 10 km. The possible incorporation of emissions into convective shower circulations may have caused the high concentrations at Mildred Lake.

#### 8.15.7 6 August 1982

The cyclone centre located over north central Alberta on 6 August 1982 had an interesting history. On the 31st of July, the centre was located on the Yukon-British Columbia border. By the morning of the 1st, the centre was over Calgary. From this position, it circled northward to just south of Lake Athabasca, where it remained until it dissipated on the 6th.

Light-to-moderate precipitation fell across the AOSERP network (1.4 to 15.4 mm). Stations reporting elevated concentrations, Ells ( $\text{NO}_3^-$ ,  $\text{SO}_4^{2-}$ , pH), Legend ( $\text{Ca}^{2+}$ , pH), Bitumount ( $\text{NO}_3^-$ ),

Johnson Lake ( $\text{NO}_3^-$ ) and Muskeg ( $\text{NH}_4^+$ ,  $\text{NO}_3^-$ ,  $\text{SO}_4^{2-}$ ), were all located north of the Suncor and Syncrude sources. Air flows during this time were likely complex, but southerly winds were quite possible for portions of this period.

#### 8.15.8 11 August 1982

A cold front extending south-southeastward from a low in the southern Yukon on the 10th of August moved to extend from a low north of Great Slave Lake south to eastern Alberta on 11 August 1982. By the morning of the 12th, the front had moved to a line through eastern Lake Athabasca. Winds on the morning of the 11th at Fort McMurray were southeasterly, and shifted through the south to westerly with the passage of the front.

Precipitation across the network ranged from 1.2 to 14.0 mm. Six sites reported high concentrations: Keane ( $\text{Na}^+$ ,  $\text{NH}_4^+$ ,  $\text{NO}_3^-$ ,  $\text{SO}_4^{2-}$ ), Johnson Lake ( $\text{NH}_4^+$ ,  $\text{Ca}^{2+}$ ,  $\text{NO}_3^-$ ), Muskeg ( $\text{NO}_3^-$ ), Thickwood ( $\text{NO}_3^-$ ), Gordon Lake ( $\text{Na}^+$ ,  $\text{NH}_4^+$ ,  $\text{NO}_3^-$ ,  $\text{SO}_4^{2-}$ , pH), and Grande ( $\text{NO}_3^-$ ).

#### 8.15.9 1 June 1984

An occluded low (98.8 kPa) was located just south of Lake Athabasca on 1 June 1984. This cyclone had moved northeastward into this position from the Vancouver-Seattle area on May 29th. On the 2nd, the low continued to move northeastward to northeastern Saskatchewan and began to fill (100.0 kPa). An occluded front curled from the north sector of the low pressure centre through eastern Lake Athabasca toward Churchill, Manitoba and then southward to a low in northwestern Ontario.

Precipitation was generally heavy in the AOSERP network. Eight sites measured over 25 mm of rainfall. Six stations along a southwest-northeast line through the Suncor and Syncrude source region reported elevated concentrations of sulphate: Grande ( $\text{K}^+$ ,  $\text{Ca}^{2+}$ ,  $\text{SO}_4^{2-}$ ), Thickwood ( $\text{SO}_4^{2-}$ ), Fort McMurray ( $\text{SO}_4^{2-}$ ), Mildred Lake ( $\text{SO}_4^{2-}$ ), Muskeg ( $\text{Ca}^{2+}$ ,  $\text{SO}_4^{2-}$ ), and Johnson Lake ( $\text{SO}_4^{2-}$ ).

8.15.10 5 June 1984

A low pressure cell (100.0 kPa) located over the Calgary area on the morning of 5 June 1984 had moved to this position from the eastern Yukon-British Columbia border on the 4th and deepened. The centre became stationary over southern Alberta, moving only slightly from its position on the 5th by the morning of the 6th.

Less than 4 mm of precipitation fell at stations in the AOSERP network. However, five stations reported elevated concentrations: Buckton ( $\text{Mg}^{2+}$ ,  $\text{Ca}^{2+}$ ), Birch Mountain ( $\text{K}^+$ ,  $\text{Mg}^{2+}$ ,  $\text{Ca}^{2+}$ ,  $\text{SO}_4^{2-}$ ), Bitumount ( $\text{K}^+$ ,  $\text{NH}_4^+$ ,  $\text{Ca}^{2+}$ ,  $\text{SO}_4^{2-}$ ), Thickwood ( $\text{K}^+$ ,  $\text{Mg}^{2+}$ ), and Stony Mountain ( $\text{Mg}^{2+}$ ,  $\text{Ca}^{2+}$ ).

8.15.11 29 June 1984

A cyclonic storm system moved from southwestern Washington State on the 28th to over Calgary on 29 June 1984 with a warm front extending northeastward and a cold front trailing to the southwest. This low continued to move north-northeastward to Lake Athabasca and deepened from 100.4 kPa on the 29th to 98.8 kPa on the 30th.

Precipitation ranged from 0.6 to 26.2 mm over the network. Elevated concentrations were reported at Edra ( $\text{Mg}^{2+}$ ,  $\text{Ca}^{2+}$ ,  $\text{SO}_4^{2-}$ , pH), Buckton ( $\text{Ca}^{2+}$ ,  $\text{NO}_3^-$ ), Birch Mountain ( $\text{Mg}^{2+}$ ,  $\text{Ca}^{2+}$ ), Legend ( $\text{Ca}^{2+}$ ), Johnson Lake ( $\text{Na}^+$ ,  $\text{Mg}^{2+}$ ,  $\text{Ca}^{2+}$ ,  $\text{SO}_4^{2-}$ ), and Stony Mountain ( $\text{Mg}^{2+}$ ,  $\text{Ca}^{2+}$ ).

8.15.12 4 August 1984

No fronts or lows were found in the northern Alberta area on the morning of 4 August 1984. The province was under a slight southwest-northeast pressure gradient. Development of a low pressure cell began late in the day in northeastern Alberta, and by 0500 MST of the 5th, a low pressure cell (101.2 kPa) was located over western Lake Athabasca. On the morning of the 4th, Fort McMurray was reporting light rain under southwest winds.

High concentrations were reported at Johnson Lake ( $\text{Ca}^{2+}$ ,  $\text{SO}_4^{2-}$ ), Bitumount ( $\text{NO}_3^-$ ,  $\text{SO}_4^{2-}$ , pH), Legend ( $\text{SO}_4^{2-}$ , pH) Muskeg (pH) and Birch Mountain ( $\text{Ca}^{2+}$ ).

#### 8.15.13 6 August 1984

On the morning of 6 August 1984, a number of low pressure cells were located in the Alberta area. Two were located south of Alberta in the United States, one in the southeast corner of the Yukon, and one in northern Alberta. A stationary front extended from the eastern Yukon to James Bay. The low over northern Alberta remained quasi-stationary from the 5th to the 7th and deepened from 101.0 kPa on the 5th to 100.8 kPa on the 6th and 100.4 kPa on the 7th.

Five stations reported elevated concentrations: Richardson ( $\text{SO}_4^{2-}$ , pH), Buckton ( $\text{Ca}^{2+}$ ), Legend ( $\text{Ca}^{2+}$ ,  $\text{SO}_4^{2-}$ , pH), Bitumount ( $\text{Ca}^{2+}$ ,  $\text{SO}_4^{2-}$ , pH), and Muskeg ( $\text{SO}_4^{2-}$ , pH).

This material is provided under educational reproduction permissions included in Alberta Environment's Copyright and Disclosure Statement, see terms at <http://www.environment.alberta.ca/copyright.html>. This Statement requires the following identification:

"The source of the materials is Alberta Environment <http://www.environment.gov.ab.ca/>. The use of these materials by the end user is done without any affiliation with or endorsement by the Government of Alberta. Reliance upon the end user's use of these materials is at the risk of the end user.