



**COMPARISON BETWEEN
RCORD BASED FTTH NETWORK
& TRADITIONAL GPON BASED
FTTH NETWORK**

**MASTER'S IN
INTERNETWORKING**

SNEHPREET KAUR

ACKNOWLEDGMENT

I would like to express my gratitude to my mentor Mr. Juned Noonari under whose guidance I am able to complete this project. I will like to thank him for all the remarks, support, guidance and his involvement through the learning process of my Capstone Report. I have provided efforts in my project however; this project wouldn't be possible without the constant support he has provided me. Every time he has been patient listening to my viewpoints and providing me with all the support that I need. From the moment I chose this project till this time he has always shown the right path to complete this very patiently.

Furthermore, I would also like to express my gratitude to Dr. Mike MacGregor and Mr. Shahnawaz Mir for providing me with all the guidance throughout this phase.

At last, I would also like to regard all the MINT faculty for always providing me help whenever needed.

ABSTRACT

With the rapid increase and demand for advanced services like video conferencing, internet, distance learning, IPTV etc. makes the service providers think that how they can fulfill the requirements of customers. The copper cables, on the other hand, has limited capacity and speed. These limitations of copper cables made the service providers search for advanced technologies.

One of the most powerful technology these days is the optical fiber because in comparison with the copper cables these are faster and has greater bandwidth because it uses light impulses instead of electrical signals for data transmission. Also, it is immune to electromagnetic interferences and less susceptible to signal degradations. For the transmission of the signal, bandwidth is used, and it indicates to the speed at which signal can be transmitted as well as the amount of data that can be carried. For the measurement of bandwidth megabit per second or gigabit per second is used. The benefits of fiber-optic cable in contrast with copper cable brought about three critical changes: Huge capacity increment, cost decreases for the hardware, for operations and maintenance, Quality of service is also improved.

Even though fiber optics conquers the vast majority of these confinements, one of the obstructions in providing fiber-optic services straightforwardly to living arrangements and independent ventures, including small workplaces and home workplaces has been the surprising expense of associating every subscriber to the CO. A high number of point-to-point (P2P) associations would require numerous active components and a high-fiber-count link, in this way leads to restrictive installation and the costs for maintenance in contrast with conventional copper arranged network.

Fiber-to-the-home (FTTH), also called fiber-to-the-premises (FTTP), provides a point-to-multipoint (P2MP) connection that offers an attractive solution to these problems. With FTTH P2MP PON, there are no active components between the CO and each subscriber, allowing several subscribers to share the same connection. This is accomplished by using one or more passive splitters to connect, in some cases, up to 32 subscribers to the same feeder fiber. This P2MP architecture dramatically reduces network installation, management, and maintenance costs.

In this report, I will explain the traditional method of the GPON (Gigabit Passive Optical Networks) based FTTH network and the comparison of it to the upcoming RCORD (Residential Central Office Re-architected as a Datacenter) based FTTH network. At the end a possible model of implementation of FTTH network for GPON and RCORD in the City of Leduc is given and based on it the appropriate measurement and analysis is done based on the operational, technical and economical parameters.

Table of Contents

FTTH	9
1.1 HISTORY	9
1.2 WHAT IS FTTH	10
1.3 FTTx Network Architecture	11
1.4 FTTH TYPES	11
1.4.1 POINT TO POINT(P2P)	12
1.4.1 ARCHITECTURE	12
1.4.2 Advantages of P2P Technology for FTTH:	13
1.4.3 POINT TO MULTIPOINT (THIS IS USED IN GPON)	13
1.4.4 Architecture	14
1.4.5 Advantages of P2MP/PON Technology for FTTH:	14
1.5 Benefits of FTTH over Traditional Methods	15
1.6 METHODS TO ESTABLISH OPTICAL FIBER	15
1.7 THE LAYERS OF THE FTTH NETWORK	16
1.8 5G FIBER REQUIREMENT	17
1.9 FTTH NETWORK SHARING	18
1.9.1 Duct sharing in North America	19
1.9.2 SEWER SYSTEM	19
1.9.3 WATER PIPES	19
1.10 THE LARGEST INVESTORS IN THE FIBER	20
1.10.1 HOW THEY ACHIEVED IT	21
1.11 FIBER CABLES FOR FTTH	21
CHAPTER 2	23
PON	23
2.1 PON	23
2.2 PON TOPOLOGY	23
2.3 TYPES OF PON	23
2.3.1 TDM PON	24
2.3.2 WDM PON	33
2.3.3 OFDM PON	34
2.4 EVOLUTION OF PON	35
2.5 PARTS OF PON:	36

2.6 PON IMPLEMENTATION	39
2.6.1 Fiber	40
2.6.2 Drop Terminals	41
2.7 The testing of PON Installation	41
2.7.1 The connection of the connector and how it is maintained	41
2.7.2 IMPORTANT THINGS TO NOTICE WHILE THE TESTING	43
2.8 ADVANTAGES OF USING PON	43
CHAPTER-3	45
GPON	45
3.1 WHAT IS GPON AND WHY IS IT USED	45
3.2 THE STANDARDS OF GPON	46
3.3 GPON NETWORK MODEL REFERENCE	47
3.4 THE FUNDAMENTALS OF GPON	47
3.5 THE FEATURES OF GPON	48
3.6 GPON FRAME FORMAT AND MULTIPLEXING	48
3.6.1 (FROM ONU/ONT TOWARDS OLT): UPSTREAM TRAFFIC	49
Reference: http://www.gpon.com/how-gpon-works	51
3.6.2 FROM OLT TO ONU: DOWNSTREAM TRAFFIC	51
Reference: http://www.gpon.com/how-gpon-works	51
3.6.3 GEM (GPON Encapsulation Method)	53
3.6.4 SERVICE MAPPING	54
3.6.5 T-CONT	54
3.7 GPON TECHNIQUES	56
3.8 COMPONENTS OF GPON	59
3.8.1 OLT (Optical Line Terminal)	59
3.8.2 ONT/ONU (OPTICAL NETWORK TERMINAL)/ (OPTICAL NETWORK UNIT) 61	
3.8.3 SPLITTER	62
3.8.4 ODN (OPTICAL DISTRIBUTION NETWORK)	63
3.9 GPON FTTH ARCHITECTURE	64
3.10 GPON NETWORK PROTECTION MODES	65
3.11 Power Budget	66
CHAPTER 4	67
CORD	67
4.1 INTRODUCTION TO CORD	67

4.2 CORD ARCHITECTURE	71
4.3 MCORD	72
4.4 ECORD	73
4.5 ACORD	74
CHAPTER 5	75
RCORD	75
5.1 INTRODUCTION	75
5.2 PURPOSE	75
5.3 TRADITIONAL RESIDENTIAL ACCESS	76
5.4 OVERVIEW OF DISAGGREGATED RESIDENTIAL ACCESS	77
5.5 Detailed Residential CORD and its components	78
5.5.1 vOLT	78
5.5.2 vSG	85
5.5.3 vRouter	87
5.6 DESCRIPTION OF RCORD	89
5.7 VOLTHA	91
5.7.1 HOW IT WORKS	93
5.7.2 DATA TRAFFIC	94
CHAPTER 6	95
SDN AND NFV	95
6.1 INTRODUCTION	95
6.2 FUNDAMENTALS OF SDN AND NFV	97
6.3 SDN	99
6.3.1 The SDN ARCHITECTURE	102
6.3.2 The working of SDN	103
6.4 NFV	103
6.5 THE ROLE OF SDN AND NFV IN RCORD	107
CHAPTER 7	110
Selection of Neighborhood	110
7.1 DIAGRAM OF CITY OF LEDUC	110
7.2 MULTIWAY MAP	111
7.3 Details of the City of Leduc	111
7.4 Implementation of GPON based FTTH Network	112
7.4.1 Technical Aspect	113

7.4.2 Civil Aspect.....	113
7.5 R-CORD DEPLOYMENT.....	114
7.6 Comparison between R-CORD and GPON based FTTH network.....	115
CONCLUSION	117
ABBREVIATIONS AND ACRONYMS.....	118

TABLE OF FIGURES

Figure 1: DEVELOPMENT OF FTTH	9
Figure 2: HOW FTTH IS DIFFERENT	10
Figure 3: FTTH P2P.....	12
Figure 4: P2P FTTH ARCHITECTURE	12
Figure 5: Optical Time Domain Reflectometer	13
Figure 6: P2MP.....	13
Figure 7: P2MP ARCHITECTURE.....	14
Figure 8: FEEDER, DISTRIBUTION, DROPS	15
Figure 9: LAYERS OF FTTH	17
Figure 12:5G DEMAND.....	17
Figure 13: AREAS OF BW REQUIREMENT	18
Figure 14: FTTH NETWORK SHARING	18
Figure 15:100 MM DIAMETER DUCT	19
Figure 16: FIBER OPTICAL CABLE IN WATER PIPE	20
Figure 17: UAE.....	20
Figure 18: VARIETIES OF FIBERS.....	21
Figure 19: TYPES OF TOPOLOGIES	23
Figure 20: DATA SPECIFICATIONS OF PON	24
Figure 21: ATM PON DOWNSTREAM.....	25
Figure 22: ATM PON UPSTREAM.....	25
Figure 23: DOWNSTREAM AND UPSTREAM TRAFFIC TYPES	26
Figure 24: TIMELINE FOR ATM DEVELOPMENT	26
Figure 25: ATM RELATED ITU RECOMMENDATIONS.....	27
Figure 26: BPON	28
Figure 27: XGPON1	29
Figure 28: XGPON2	30
Figure 29: exfo_book_fttx-pon-technology-testing_en.pdf.....	30
Figure 30: ETHERNET IN ACCESS NETWORK	31
Figure 31: EVOLUTION OF PON.....	35
Figure 32: PARTS OF PON	36
Figure 33: PON SYSTEM	36
Figure 34: WDM COUPLER.....	38
Figure 35: FIBER OPTIC CABLE.....	38
Figure 36: PATCH CORD.....	39
Figure 37: FTTH PON.....	40
Figure 38: CONNECTOR END FACE	42
Figure 39: FIBER.....	42
Figure 40: GROWTH WITH GPON	46
Figure 41: GPON REFERENCE MODEL	47
Figure 42: FTTx OPTIONS	47
Figure 43: GPON FRAME FORMAT.....	49

Figure 44:UPSTREAM FRAME.....	50
Figure 45: UPSTREAM FRAMING	50
Figure 45: UPSTREAM.....	51
Figure 46: DOWNSTREAM	51
Figure 47: FRAME FORMAT.....	52
Figure 48: MULTIPLEXING	52
Figure 49: GEM FRAME	53
Figure 50: GEM DOWNSTREAM.....	54
Figure 51: TCONT.....	55
Figure 52:GPON LAYERS.....	56
Figure 53: DBA OPERATION MODES	57
Figure 54: DBA CYCLES	58
Figure 55: AES	59
Figure 56: BLOCK DIAGRAM OLT.....	60
Figure 57: SPLITTER.....	63
Figure 58: ODN	64
Figure 59: GPON FTTH ARCHITECTURE.....	65
Figure 60: MULTI-TIER CLOUD	67
Figure 61: DATA CENTER	70
Figure 62: CORD ARCHITECTURE.....	71
Figure 63: COMMON PLATFORM FOR ALL.....	76
Figure 64: TRADITIONAL RESIDENTIAL ACCESS	76
Figure 65: DISAGGREGATION.....	77
Figure 66: DISAGGREGATED OLT.....	79
Figure 67: GPON OLT IO Blade.....	80
Figure 68: vOLT AS CONTROL APP	81
Figure 69: CPE REBOOTED FOR FIRST TIME	83
Figure 70: ARCHITECTURE OF VLAN	84
Figure 71: Control plane architecture of the vRouter	87
Figure 72: Components that make up the vRouter ONOS app.....	88
Figure 73: RCORD ARCHITECTURE.....	89
Figure 74: VOLTHA.....	91
Figure 75: VOLTHA.....	92
Figure 76: DEMONSTRATION OF CORD DEPLOYMENT	93
Figure 76: DATA AND CONTROL PLANE.....	98
Figure 77: NFV vs SDN	99
Figure79: Separation of control plane into the controller	101
Figure 80: ONF SDN ARCHITECTURE.....	102
Figure 81: From dedicated hardware-based appliances for network services to	104
Figure 82: NFV architectural framework.....	105
Figure 83: NFVand SDN Industry	107
Figure 84: From proprietary appliances to an open, virtualized environment.....	108
Figure 85:CITY OF LEDUC	110

CHAPTER 1

FTTH

1.1 HISTORY

Around 70's cable TV and telephone service providers realized the importance of using fiber instead of metallic cables. Due to fiber technology still in its initial stage, it came with a lot of challenges for the service providers to achieve the required results.

However, to move ahead the service providers used fiber to the curb (FTTC), FTTN (Fiber to the node), FTTB (Fiber to the building) and hybrid fiber or coax using the trunk lines but using conventional methods of metallic cable to connect the customer to the network.

With the increase in the requirements in the market for the speed and efficiency, old conventional methods were not enough to serve the demand. Continuous developments were made during the course of time leading to the FTTH (Fiber to the home). Following diagram illustrates the development of FTTH.

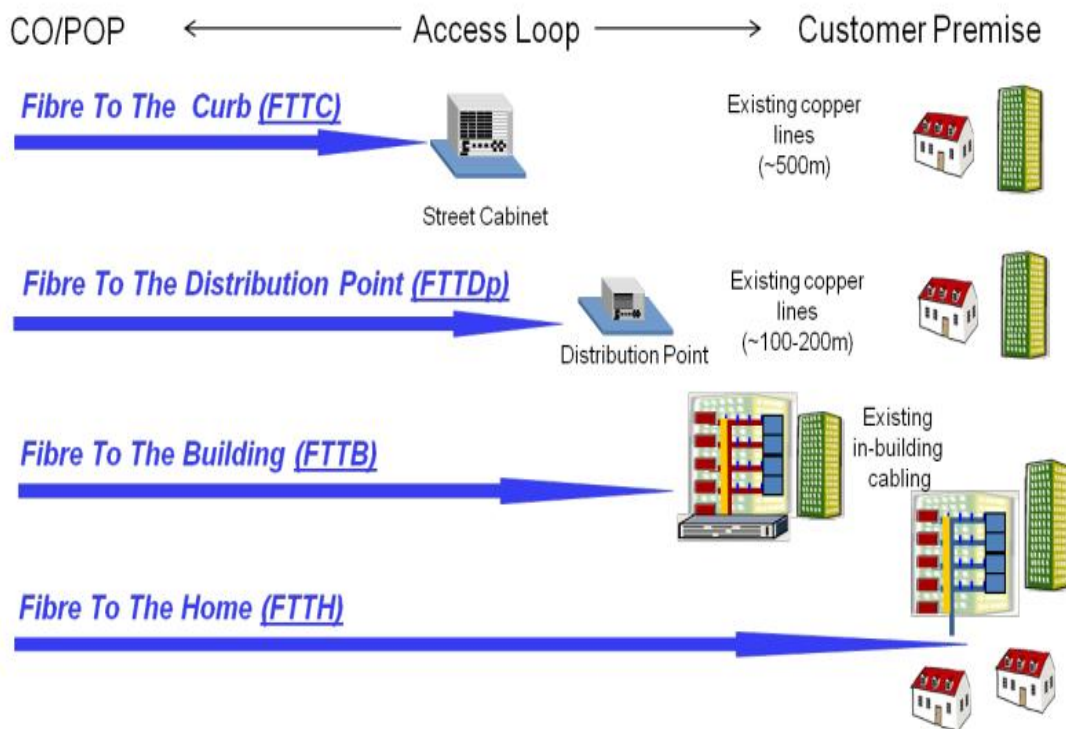

Figure 1: DEVELOPMENT OF FTTH

Reference: <https://repository.widyatama.ac.id/xmlui/bitstream/handle/123456789/9050/Bab%202.pdf?sequence=11>

1.2 WHAT IS FTTH

FTTH is Fiber to the Home network and is a fixed method used for the access of the network technologies. The fiber from the central office is directed to the buildings can be residential, apartment or business and it provides high-speed internet. The following illustration will explain how FTTH is different:

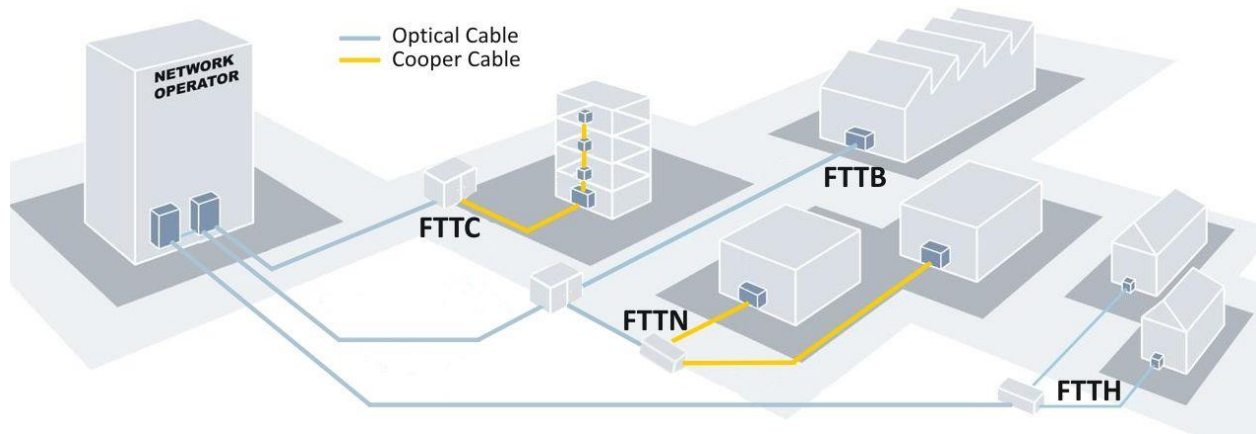

Figure 2: HOW FTTH IS DIFFERENT

Reference:<https://www.semanticscholar.org/paper/UWB-over-Fibre-in-Next-generation-Access-Networks-Beltr%C3%A1n/1e1538443379fce83b56fc2a08c80409c354f704>

Fiber-based access network connects many subscribers to a central office which is called Access node. Every node is provided with active equipment that is used for providing services to customers with the help of optical fiber. Every access node in a smaller region is connected to a vast fiber network like metropolitans.

The access networks might consist of some of the following components:

- a) A wireless network antenna that is fixed
- b) The base stations for the mobile network
- c) The customers in Single-family unit
- d) The area such as schools, hospitals
- e) The security and proper working of it like alarms, cameras, sensors

The major considerations that are to be taken under notice when deploying an infrastructure are:

- a) What is the type of FTTH?
- b) How much is the requirements of the space for the network?
- c) The estimated cost required to deploy the infrastructure
- d) The cost included for the proper functioning of the network when it will run, and the cost involved to maintain it.
- e) What sort of the network architecture it will be like GPON, RCORD?

Once the above considerations are done then the next step is to find out the appropriate infrastructure deployment method. The following methods are available to deploy it:

- a) The conventional underground duct and cable method
- b) The blown micro-ducts and cable method
- c) The direct burial method
- d) The aerial cable method

1.3 FTTx Network Architecture

1. Fiber to the home (FTTH) –

In case of the fiber to the home, every subscriber has its own dedicated fiber to a port on the equipment like in the POP, splitters, feeder fiber to POP and 100 BASE-BX10 transmission for Ethernet technology or in case of P2MP is the GPON technology.

2. Fiber to the building (FTTB) –

Each optical termination box in the building (often located in the basement) is connected by a dedicated fiber to a port in the equipment in the POP, or to an optical splitter which uses shared feeder fiber to the POP. The connections that are between the customers and building switch do not importantly need to be fiber it can be copper. For the best utilization of the existing fibers in specific topologies, the switches are not connected to the POP but instead are connected in ring or chain structure. This also saves fibers and ports in the POP. The concept of routing fiber directly into the home from the POP or through the use of optical splitters, without involving switches in the building, brings us back to the FTTH scenario.

3. Fiber to the curb (FTTC) –

Each switch/or DSL get to the multiplexer (DSLAM), frequently found in a road cabinet, is associated with the POP by means of an individual fiber or a couple of fibers, conveying the accumulated traffic of the area by means of Gigabit Ethernet or 10 Gigabit Ethernet association. The switches in the street cabinet are not fiber but can be copper based using VDSL2 or VDSL2 Vectoring. These types of architectures are referred to as “Active Ethernet” it is called so since there is a requirement of active elements for this.

4. Fiber to the Distribution Point (FTTDp) –

This solution has been proposed in the last two years. With the help of optical cable, the POP is connected to Distribution Point and this point to the subscriber home is connected with the copper infrastructure. The Distribution Points could be a hand-hole, a drop box on the pole or located in the basement of a building. This architecture could support VDSL or GFast technology for a short last mile, normally less than 250m.

1.4 FTTH TYPES

Further FTTH is broadly divided into two types:

- 1.P2P (Point to Point)
2. Point to Multipoint (This is used in GPON).

1.4.1 POINT TO POINT (P2P)

FTTH P2P network is as the name suggest, point to point network structure. Each subscriber has its own fiber optic line. The following illustration will exemplify the concept:

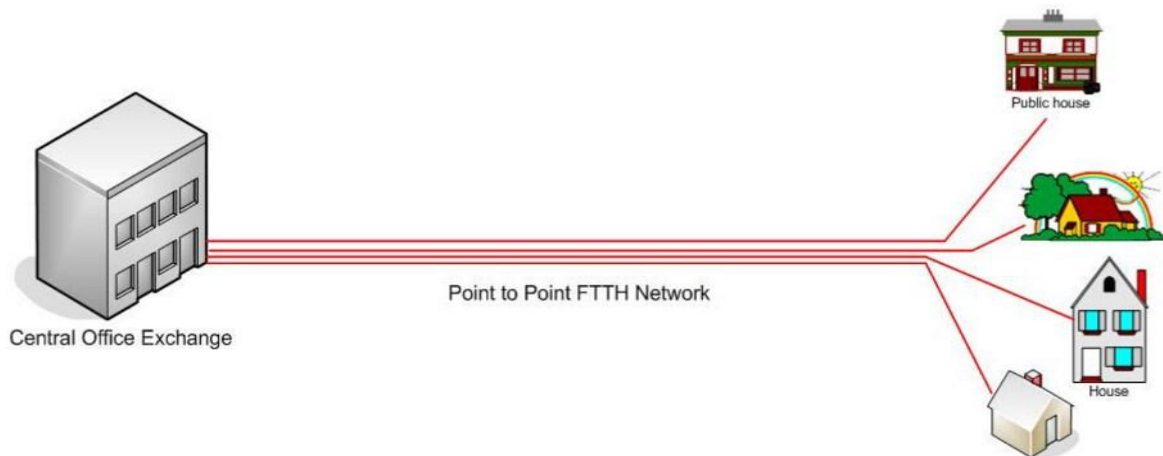

Figure 3: FTTH P2P

Reference: <https://www.google.co.in>

1.4.1 ARCHITECTURE

P2P has a core switch at the Central Office that connects over Optical Fiber cables to an aggregation switch at the distribution points. The aggregation switches have many fiber ports and each fiber port will directly connect to an ONT (Optical Network Termination point) placed at the residential premises using fiber cables. From here subscribers or users can use any access technology like wireless access points to complete the connection to their PC and other devices. The following illustration will explain this concept:

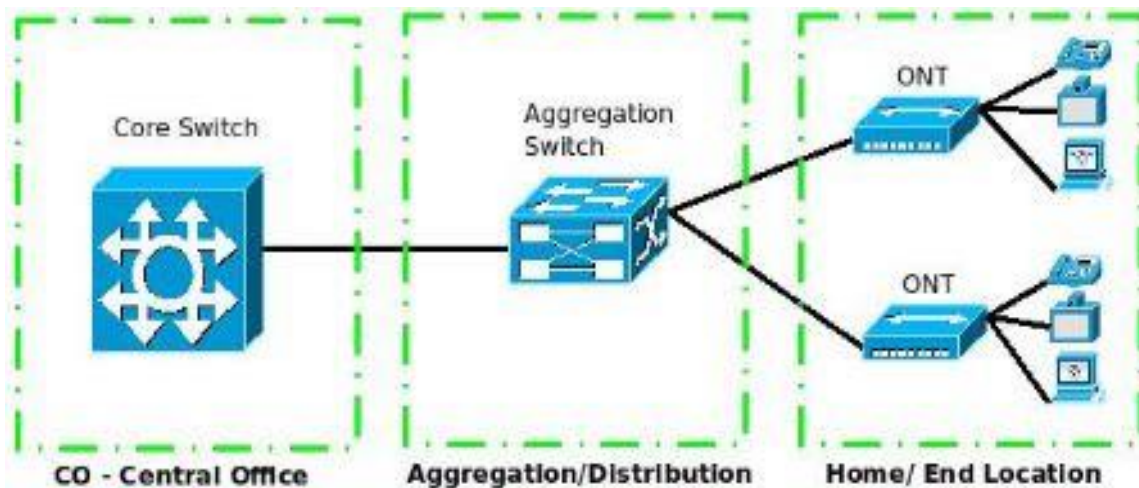

Figure 4: P2P FTTH ARCHITECTURE

Reference: <https://www.excitingip.com/2496/what-is-ftth-fiber-to-the-home-advantages-of-p2p-vs-p2mpon-architectures/>

1.4.2 Advantages of P2P Technology for FTTH:

- The bandwidth in each port of the aggregation switch is dedicated to individual homes and there is no sharing of bandwidth. That means that every customer premise will have higher bandwidth per port with this.
- The bandwidth that is provided through this is symmetric bandwidth. By symmetric, we mean that the upstream and downstream bandwidth is equal which is very useful in cases like for the Peer to peer file transfer and video conferencing.
- P2P is considered as standard and every customer can be provided the limited access to the bandwidth as per the requirement of them.
- P2P has the capability of providing 100+KM distances using fiber in comparison to the P2MP that can only provide +20. So, the faults can be troubleshooted easily with the help of the device called Optical Time Domain Reflectometer as shown below.

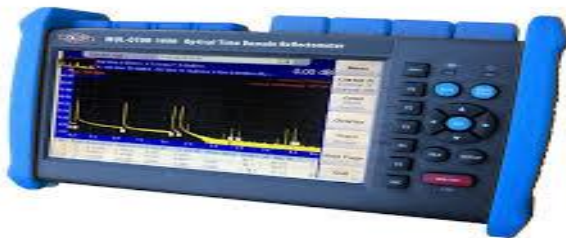

Figure 5: Optical Time Domain Reflectometer

Reference: <https://multicomstore.com/multicom-mul-otdr-1000-optical-time-domain-reflectometer-3133.htm>

- It is better to view videos using multicasting with this technology.

1.4.3 POINT TO MULTIPOINT (THIS IS USED IN GPON)

As the name suggest Point to Multi-Point/Passive Optical Network Connectivity Architecture that uses Passive Optical Splitter at the aggregation layer. The following diagram will explain:

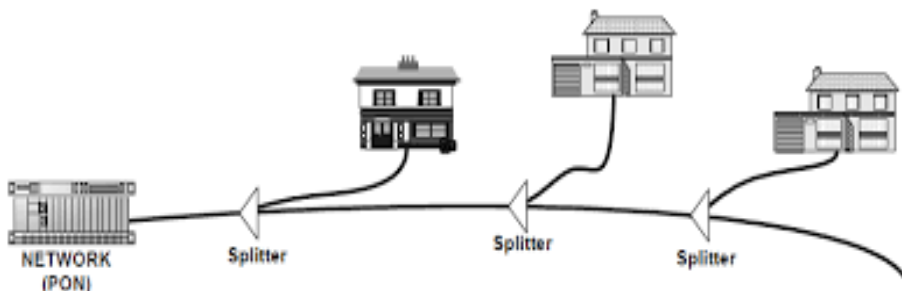

Figure 6: P2MP

Reference: <https://www.google.co.in>

1.4.4 Architecture

The Point to Multipoint (P2M)/Passive Optical Network architecture is the same as P2P except in the distribution points. Instead of Active switches with Fiber Ports, it uses Passive Splitters. These splitters can divide an optical signal into 32, 64 or even 128 shared connections without any power supply. The same signal is sent to all the premises beyond splitter but each ONT's in each receiving end know how to decode the information mean only for itself. ONTs used in P2P are different than P2M. Between all these shared connections the bandwidth is shared. Following diagram is a good illustration of P2M:

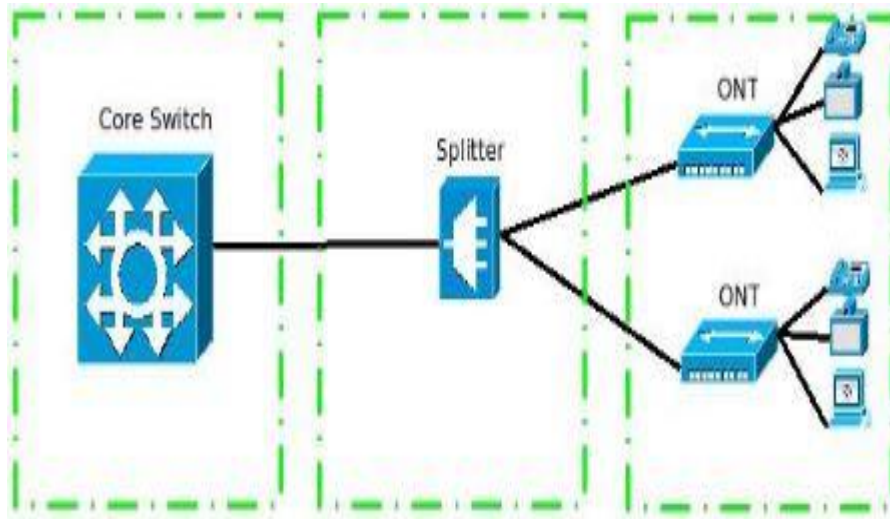

Figure 7: P2MP ARCHITECTURE

Reference:<https://www.excitingip.com/2496/what-is-ftth-fiber-to-the-home-advantages-of-p2p-vs-p2mpon-architectures/>

1.4.5 Advantages of P2MP/PON Technology for FTTH:

1. The implementation and maintenance of P2MP technology is less expensive. It uses fewer active ports to terminate fiber and uses lesser fiber cables.
2. There is no requirement of power supply for the fiber splitters so they can be placed on the field anywhere as per the requirement of the project. So, the installation flexibility is more.
3. Every connection can be secured to a good extent with the help of encryption.
4. It provides higher downstream transmission capacity and lower upstream transfer speed is like current broadband advancements. Both are adequately and significantly high (GPON, for instance, can offer up to 2.5 Gbps of downstream data transfer capacity and 1 Gbps of upstream transmission capacity, however, that is shared between 32/64 subscribers).
5. To watch television an individual can utilize conventional/computerized set-top boxes through fiber links utilizing PON innovation as these signs can be carried on an extra wavelength. In comparison to IP set-top boxes, these set-top boxes are less expensive.
6. As the air-conditioning comfort is needed for fiber switches there is no such requirement for the splitters even for the industrial environments.

1.5 Benefits of FTTH over Traditional Methods

- It has the capacity to carry lots of information
- It can be easily upgraded
- Its installation is easy
- It allows fully symmetric services
- The maintenance is cheap
- It has a larger coverage area
- It is strong, flexible, and reliable
- It supports smaller diameter and lightweight cables
- It is safe
- It is Immune to electromagnetic interference (EMI)

1.6 METHODS TO ESTABLISH OPTICAL FIBER

There are two methods to establish the Optical fiber which are Active and Passive. GPON (Gigabyte capable passive optical network) comes under the passive method.

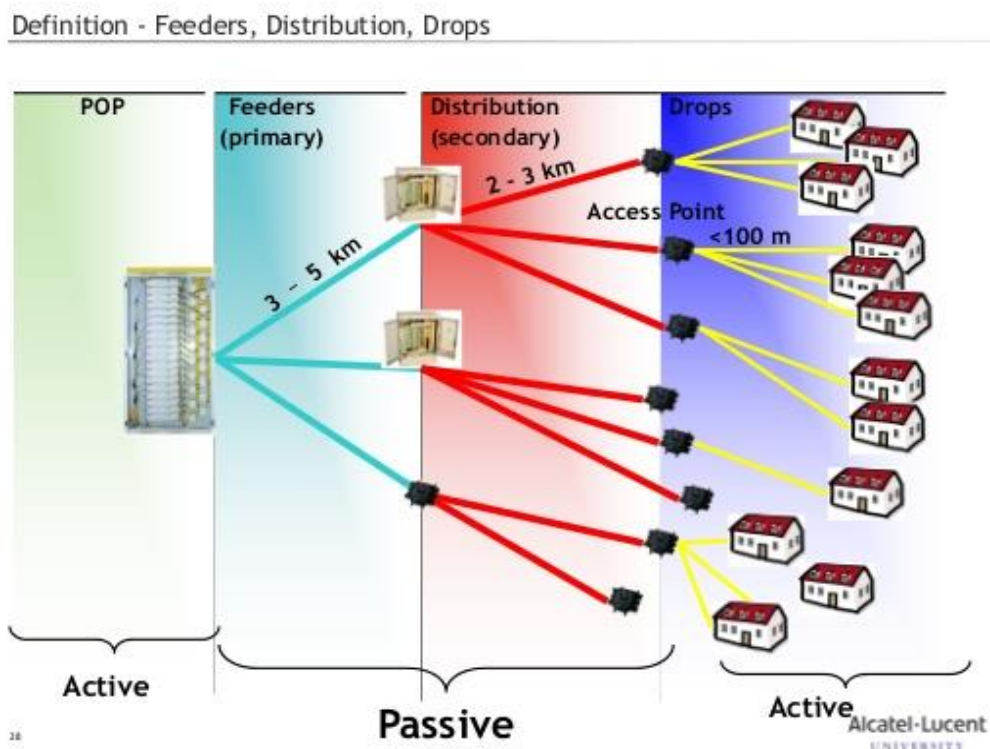

Figure 8: FEEDER, DISTRIBUTION, DROPS

Reference: <https://present5.com/po-n-passive-optical-networking-objective-at-the-end/>

1.7 THE LAYERS OF THE FTTH NETWORK

The FTTH network consists of five layers which are listed below:

1. Content Layer
2. End-user
3. Retail
4. Active network
5. Passive network

Every layer has its own assigned function that it needs to perform which is as follows:

Users:

It includes all the persons that are using the FTTH network. So they are the customers for which all the network is designed.

Services related to retail:

It involves all the customer-related services such as providing them with internet connectivity, technical support etc.

Active Infrastructure

It is that part that is used to keep the passive network alive which involves electronic equipment, operational support. The persons involved in this will be responsible to design and operate this part.

Passive Network

This part involves all the physical equipment's such as ducts, optical fibers, splicing etc. This part is responsible for the route that the network will choose, also includes the installation of fiber. I network.

Network Planning

The network planning is one of the major aspects to consider since based on it we can avoid the major failures as well as overspending. For the projects that are not properly planned can lead to delays and financial losses. The infrastructures that are not properly designed can lead to flaws in the final output.

So, there should be proper planning before any execution that will result in savings of the project.

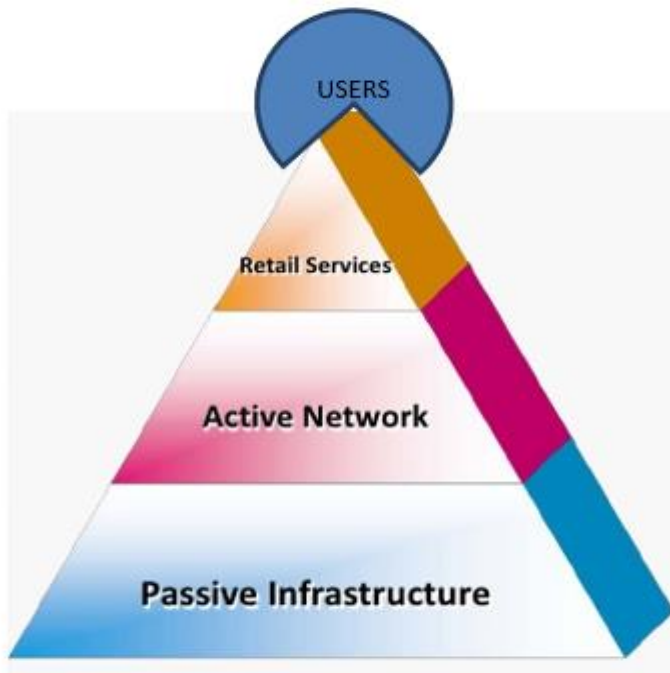

Figure 9: LAYERS OF FTTH

Reference: <https://www.slideshare.net>

1.8 5G FIBER REQUIREMENT

The 5G base station defined by ITU-T requirement is to 20 Gbps download and 10 Gbps upload and this can only be achieved by the fiber. There is a requirement of critically low latency as in the cases of self-driving connected cars, remote robotic surgery etc. and for this again it needs fiber. The 5G requirement is the whole new network coverage with the help of the fiber.



Figure 10:5G DEMAND

Reference: OFC_2018_BBF_NG-PON2_workshop.pdf

Fiber optic sensing uses laser interrogation of fiber optic cable that helps in the fastest detection of leaks in the pipeline, traffic jams, digging activities, natural disasters detection, unsafe temperatures, and various other applications. So, generally, it helps to detect the problem even if we sit miles away from the affected area.

The requirement of bandwidth in the following areas:



Figure 11: AREAS OF BW REQUIREMENT

Reference: OFC_2018_BBF_NG-PON2_workshop.pdf

1.9 FTTH NETWORK SHARING

The new FTTH networks installation requires lots of financial investment for deploying new cables for outside plants, MDU. The solution for this could be the sharing of infrastructure costs by multiple competing vendors so even non-telecom vendors might get the opportunity of participating in FTTH build outs, e.g. utilities, municipalities. But, cooperation among these vendors should be done by regulatory authorities.

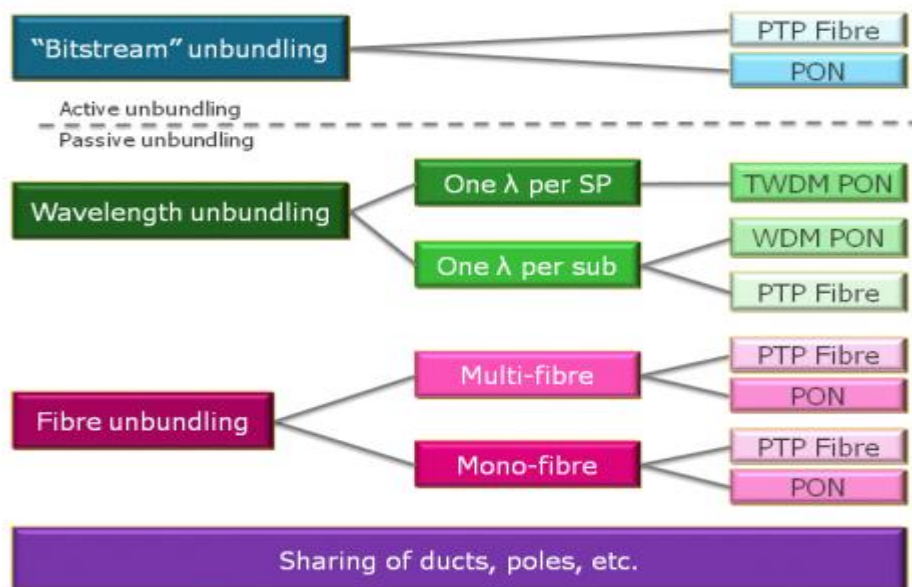

Figure 12: FTTH NETWORK SHARING

Reference: <https://www.google.co.in>

1.9.1 Duct sharing in North America

To reduce the costs of the FTTH networks one way is to share the ducts. The two principles that need to be considered while doing this is:

- a) There is a requirement of sub-ducting that means the cables from different operators in the same duct must be separated.
- b) Each operator whosoever deploys the cable first needs to take the guarantee that he leaves enough space so that the other competitive vendors can also deploy the cable of the same size.

Now, most of the operators are using the infrastructure of the duct which was originally designed for use of only one operator so the efficient use of the duct capacity that is remaining is really important. In comparison with the rigid inner ducts, the flexible textile inner ducts take up to three times less space that maximizes the number of cables that can be installed.

The following picture shows the 100-mm inner diameter duct that contains three rigid sub-ducts so the design is to hold three cables, but as we can see there is a lot of wastage of space. With the use of flexible inner duct, it is possible to add more cables to this already congested duct in this case three in from three alternative operators.

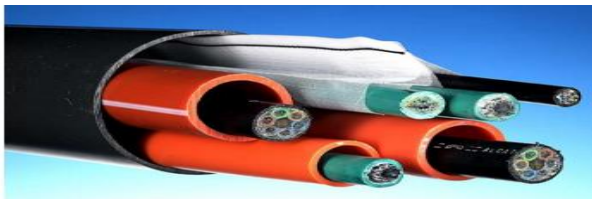

Figure 13:100 MM DIAMETER DUCT

Reference:https://www.ftthcouncil.eu/documents/Publications/DandO_White_Paper_2_2014.pdf

1.9.2 SEWER SYSTEM

With the installation of fiber optic cables, the sewer system can be reached to more residents. There are some constraints involved in this system like the installation must be to the toxic gases. The installation should be compatible with the traditional sewer cleaning methods.

1.9.3 WATER PIPES

The water companies have not declared publically but to create their own network they also put control and data cables inside their drinking and wastewater pipes. In the water supply pipe, the systems require special adaptors to be installed at the start and end access points. A micro-duct is then installed between the two fitting to create a gas-tight environment in which fiber can be inserted without coming into direct contact with the water supply.

The diagram below illustrates the fiber optical cable in the water pipe.

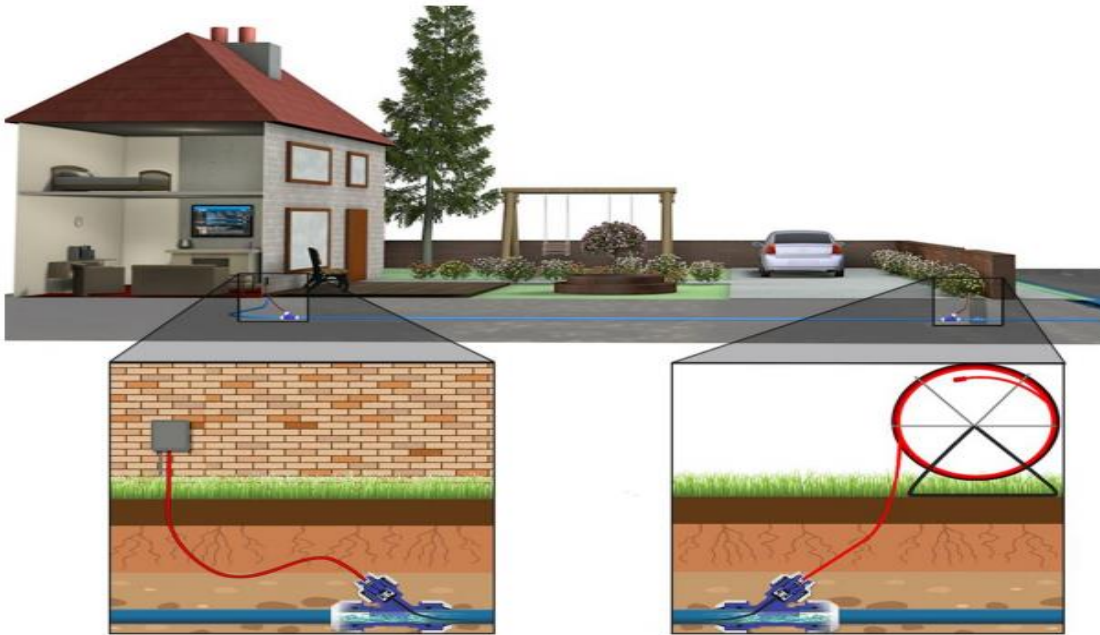

Figure 14: FIBER OPTICAL CABLE IN WATER PIPE

Reference: https://www.ftthcouncil.eu/documents/Publications/DandO_White_Paper_2_2014.pdf

1.10 THE LARGEST INVESTORS IN THE FIBER

According to a research study by the Fiber to the Home Council Middle East & North Africa, the United Arab Emirates (UAE) is the one that has the highest achievement in deploying the in fiber to the home connectivity (FTTH).

85 percent of homes in the UAE subscribe to FTTH, that has subscription rates in the next-biggest markets — South Korea, Hong Kong, Japan, Singapore, and Taiwan. The Council's chairman Dr. Suleiman Al Hedaithy at the ITU's recent World Telecommunication Development Conference (WTDC), mentioned that fiber connections are available to more than 200 million homes globally.



Figure 15: UAE

Reference: www.google.com

1.10.1 HOW THEY ACHIEVED IT

The UAE's government main focus was upon making everything FTTH based and for that, they tried to provide the best digital services.

The e-solutions include e-education, e-health, e-commerce etc. The increase in the housing and real estate and population are also the factors that are responsible for the rapid growth of FTTH. They had the vision of smart homes and cities.

With the increasing demands of the bandwidth there FTTH network is also becoming dense and vast and they are still working to increase it furthermore and improve it.

1.11 FIBER CABLES FOR FTTH

There are varieties of fibers that can be used in the FTTH which are as follows:

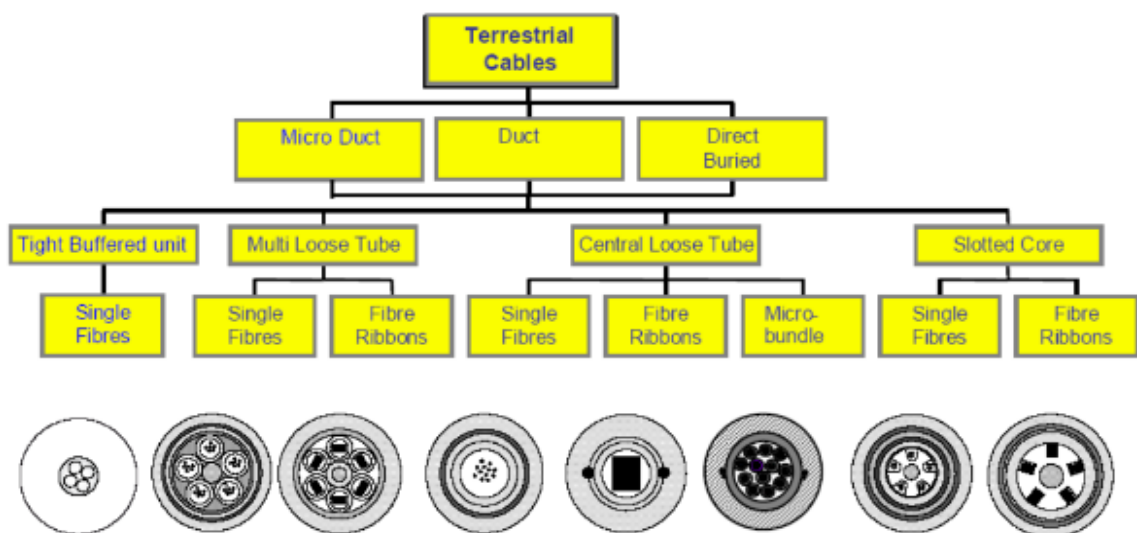

Figure 16: VARIETIES OF FIBERS

Reference: http://wiki.ftthcouncil.eu/index.php/FTTH_Handbook/Deployment_Techniques

The first type of fiber is the most basic one and is the building block is called a loose tube. The loose tube is a plastic tube that contains only the required number of fibers commonly these are 12. The plastic tube is lined with a filling compound that helps them to move within the tube as the cable expands and contracts according to environmental and mechanical extremes. Other fibers are the ones that include multiple fibers in a ribbon form. Fibers can also be laid in narrow slots. The materials that block the Water such as water-swellable tapes or grease can be used to prevent moisture permeating through the cable, which is over-sheathed with polyethylene for protection.

CONCLUSION

The investment requirements in the FTTH infrastructure has reduced and the credit goes to the service providers that use improved procedures, labor-saving advance methods and uses

innovative tools if there will be some further work done on the innovative tools it can reduce more costs in the backward areas. Only a single innovation cannot solve all FTTH cost issues.

In my project, I will be discussing the two methods that are GPON based FTTH network and RCORD based FFTH network. If the deployment cost is less for an FTTH it will speed up the pace of FTTH deployment everywhere. So, my project will mainly discuss these two technologies in the upcoming chapters.

CHAPTER 2

PON

2.1 PON

PON stands for Passive Optical Network. PON is a group of technologies that are standardized by ITU-T and IEEE. Originally, PON was created by FULL-SERVICE ACCESS NETWORK (FSAN). There are many services carried in PON such as plain old telephone service (POTS), voice over IP (VoIP) these are encapsulated in a single packet for transmission over the fiber. The maximum of the traffic about 90 percent is by the optical fiber. FTTH is known for its high bandwidth and the FTTH is using PON and so FTTH is cost effective.

The demand for passive optical network has increased worldwide. It is widely used everywhere. The choice of choosing any equipment depends upon the geography, financial parameters. Everything today depends upon ease. In today's era fiber is the most trustable source for the future bandwidth requirements.

2.2 PON TOPOLOGY

The meaning of topology is layout. It comes from a **Greek word** topos meaning place and logos meaning study. The network topology is the one in which nodes like routers, switches are connected to other network or to LAN (Local area network). There are different types of topologies such as a star, mesh, ring, bus.

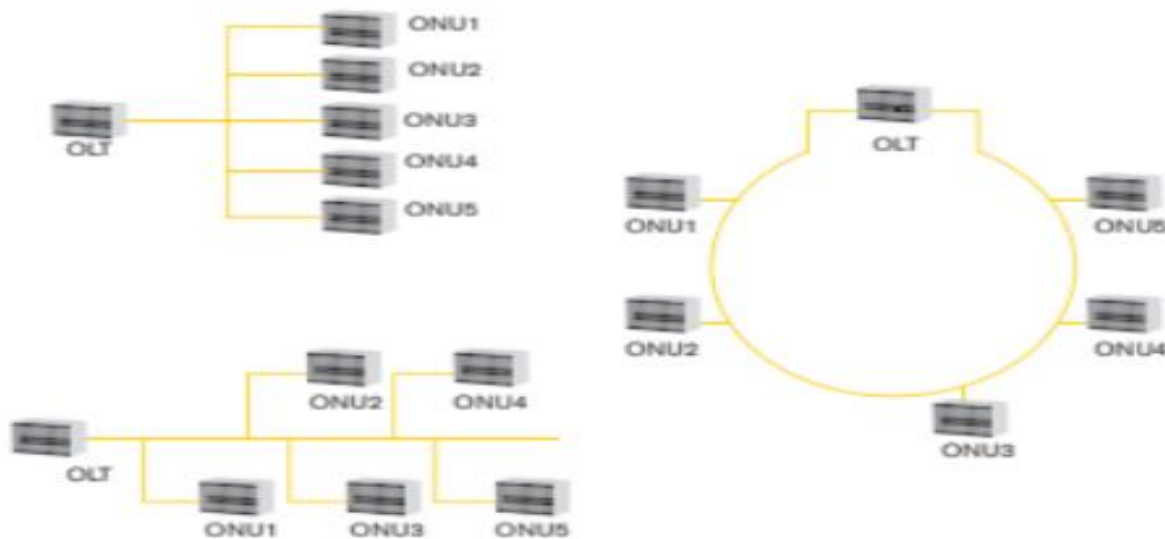

Figure 17: TYPES OF TOPOLOGIES

Reference: exfo_fttx_pon_reference_guide_en.pdf

The above diagram shows the different types of PON topologies.

2.3 TYPES OF PON

There are basically three types of PON based on multiplexing:

2.3.1 TDM PON

TDM PON is Time division multiplexing PON. In this, the traffic to and from are time division multiplexed on the upstream and downstream wavelengths. TDM is the standardized scheme for all the PON till now.

The current systems are using TDM which involves APON that is ATM-PON, BPON that is Broadband PON, GPON that is Gigabit PON that is mainly covered in my report, 10G PON, NG-PON that is next generation PON.

FSAN standardized ATM, BPON, GPON, and NG-PON. These architectures have the framing structure that has strict timing and synchronization requirement.

On the other hand, 10G PON and EPON are standardized by IEEE 802. In this model, in order to preserve the architectural model, the Ethernet frames are transmitted in bursts and inter-frame gaps.

CONCEPTS

2.3.1. A) APON: ATM Passive Optical Network

2.3.1. B) BPON: Broadband Passive Optical Network

2.3.1. C) NGPON: Next Generation Passive Optical Network

2.3.1. D) EPON: Ethernet Passive Optical Network

2.3.1. E) GEAPON: Gigabit Ethernet Passive Optical Network

2.3.1. F) GPON: Gigabit-Capable Passive Optical Network

	APON/BPON	GPON	XG-PON1	EPON	10G-EPON
Standard	ITU-T G.983	ITU-T G.984	ITU-T G.987	IEEE 802.3ah	IEEE 802.3av
Downstream speeds	622 Mbps	2.488 Gbps	9.9528 Gbps	1.25 Gbps	10.3125 Gbps
Upstream speeds	155 Mbps	1.244 Gbps	2.488 Gbps	1.25 Gbps	1.25 Gbps
			9.9528 Gbps		10.3125 Gbps

Figure 18: DATA SPECIFICATIONS OF PON

Reference: 9781461439387-c1.pdf

The above table illustrates the Data rate specifications of various PON standards

2.3.1An APON/BPON (ITU-T G.983)

APON

FSAN defined the first PON specification known as APON that is ATM-PON. In this ATM is used as the signaling protocol in layer 2.

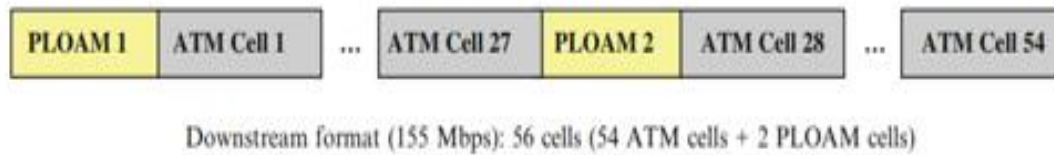

Figure 19: ATM-PON DOWNSTREAM

Reference: 9781461439387-c1.pdf

The above figure illustrates the ATM-PON for the downstream. In case of downstream transmission, there is a continuous stream at a rate of 155.52 Mb/s or 622.08 Mb/s. As per the diagram in case of downstream format, there are 56 cells that include 54 ATM and 2 (Physical layer operation, administration, and maintenance) PLOAM cells. PLOAM are inserted at the beginning and middle. Each PLOAM cell contains 27 grant fields and a 12-byte message field. To control the upstream data transmission grant fields are used, and message fields are used for controlling the operation of the ONUs.

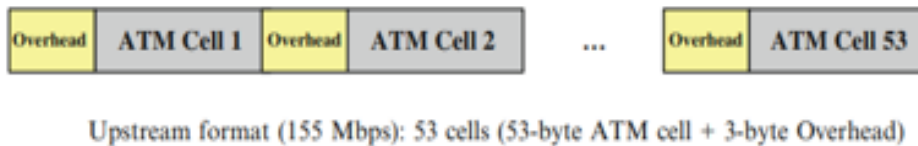

Figure 20: ATM-PON UPSTREAM

Reference: 9781461439387-c1.pdf

The above diagram illustrates the ATM-PON for the upstream. As it is clearly depicted that in this case there are 53 cells which include 53 ATM and 3 bytes overhead. In the case of ATM, the upstream transmission is done in bursts of ATM cells. The 3-byte overhead contains a minimum of four bits of guard time, a preamble, and a delimiter field. The guard time is the time that takes care that there is enough time gap between two contiguous cells to avoid the collision between them and avoid traffic congestion. The preamble is used for the bit synchronization. The delimiter is a pattern that is used to indicate the start of an incoming cell.

DOWNSTREAM AND UPSTREAM TRAFFIC TYPES:

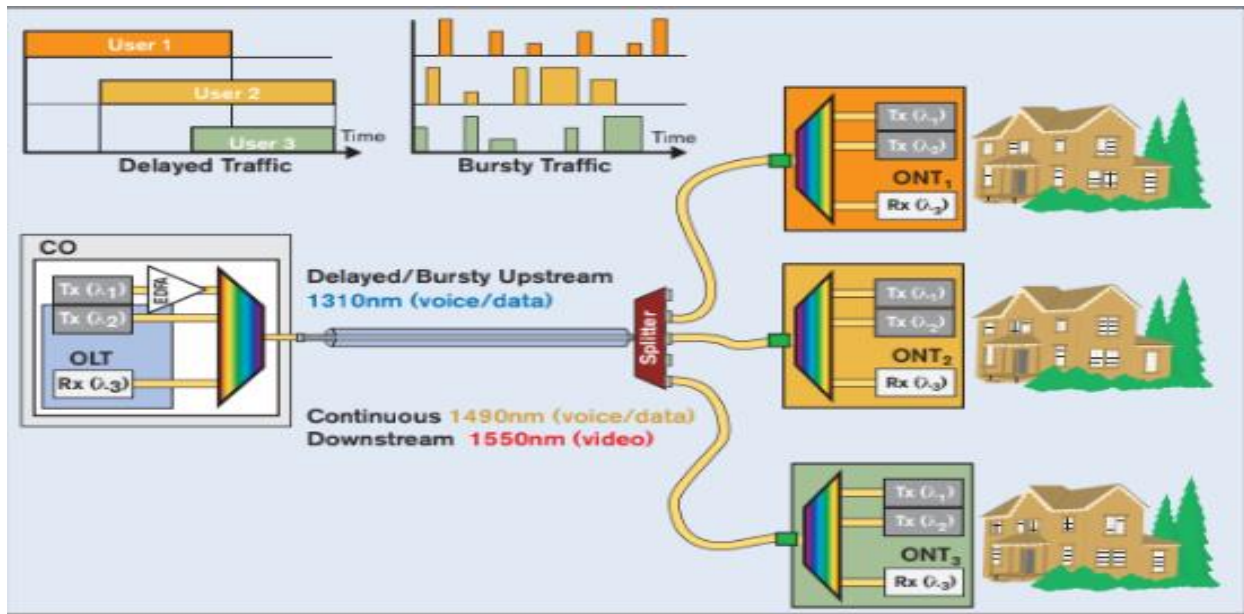

Figure 21: DOWNSTREAM AND UPSTREAM TRAFFIC TYPES

Reference: exfo_book_fttx-pon-technology-testing_en.pdf

The table shows the Timeline for ATM development:

Time Period	Event
1984	Development of ITU-T ATM related Recommendations
1984-1988	ITU-T Recommendations on: <ul style="list-style-type: none"> ■ Transmission ■ Switching ■ Signaling ■ Control ■ Support fiber-optic broadband integrated services digital network (B-ISDN)
1991	ATM Forum starts its activities
1996	Migration to multi-service networks
1998	Selection of ATM into PON related ITU-T Recommendation G.983.1

Figure 22: TIMELINE FOR ATM DEVELOPMENT

Reference: exfo_book_fttx-pon-technology-testing_en.pdf

LIST OF ATM RELATED ITU-T RECOMMENDATIONS:

Rec.	Title
I.113	Vocabulary of terms for broadband aspects of ISDN
I.150	B-ISDN asynchronous transfer mode functional characteristics
I.211	B-ISDN service aspects
I.311	B-ISDN general network aspects
I.321	B-ISDN protocol reference model and application
I.326	Functional architecture of transport networks based on ATM (1995)
I.327	B-ISDN functional architecture
I.356	B-ISDN ATM cell transfer performance
I.361	B-ISDN ATM layer specification
I.363	B-ISDN ATM adaptation layer (AAL) specification
I.364	Support of broadband connectionless data service on B-ISDN
I.365.1	Frame relay service specific convergence sublayer (FR-SSCS)
I.365.2	Service specific co-ordination function to provide CONS
I.365.3	Service specific co-ordination function to provide COTS
I.371	Traffic control and congestion control in B-ISDN
I.413	B-ISDN user-network interface
I.430	Basic user-network interface – layer 1 specification
I.432.1	B-ISDN UNI – physical layer specification general aspects
I.432.2	B-ISDN UNI – physical layer specification 155 520 kbit/s and 622 080 kbit/s
I.432.3	B-ISDN UNI – physical layer specification 1544 kbit/s and 2048 kbit/s
I.432.4	B-ISDN UNI – physical layer specification 51840 kbit/s
I.555	Frame relay bearer service interworking
I.580	General arrangements for internetworking between B-ISDN and 64 kbit/s based on ISDN
I.610	B-ISDN operation and maintenance principles and functions
I.732	Functional characteristics of ATM equipment (1996)

Figure 23: ATM RELATED ITU RECOMMENDATIONS

Reference: exfo_book_fttx-pon-technology-testing_en.pdf

2.3.1. A BPON

The ITU-T G.983 series after the APON provides a further improvement to it that is known as BPON or the Broadband PON.

For the convenient, cheaper and the early deployment, BPON offers a number of services that include ATM, Ethernet access, and video distribution. For the downstream transmission, BPON uses Wavelength division multiplexing (WDM).

It has 16 wavelengths that have 200 GHz spacing and 32 wavelengths that has 300 GHz spacing between channels. It uses churning that is an advanced security technique in this the encryption key is changed once a second between the Optical Line terminal (OLT) and the customers side the ONT (Optical Network Terminal).

Type		BPON (Broadband PON)				
Standard		ITU-T G..983 series				
Protocol		ATM				
Services		Voice/data/video				
Maximum Physical distance (OLT to ONT)	km	20				
Split ration		Up to 32				
		Downstream OLT Tx			Upstream ONU Tx	
Nominal bit rate	Mbit/s	155.52	622.08	1244.16	155.52	622.08
Operating Wavelengths band	nm	1480-1580	1480-1500	1260-1360	1260-1360 (MLM1, SLM)	
					1280-1350 (MLM2)	
					1288-1338 (MLM3)	
ORL _{MAX}	dB	>32				

Figure 24: BPON

Reference: exfo_fttx_pon_reference_guide_en.pdf

2.3.1. B NG-PON

Although GPON came before NG-PON still I will discuss this first as in the next chapter there will be whole detailed information about GPON. So, NG-PON was focused onto high bandwidth provisioning after the GPON by the ITU-T/FSAN.

NG-PON is further divided into two phases:

1. NG-PON1
2. NG-PON2

1. NG-PON1

- a) It is the one that focusses on the PON technologies that are compatible with the GPON and the ODN (Optical Distribution Network).
- b) It is compatible with the fiber installation, the extended network reaches high bandwidth provisioning and large split ratio.
- c) It specifies both asymmetric and symmetric NG-PONs.

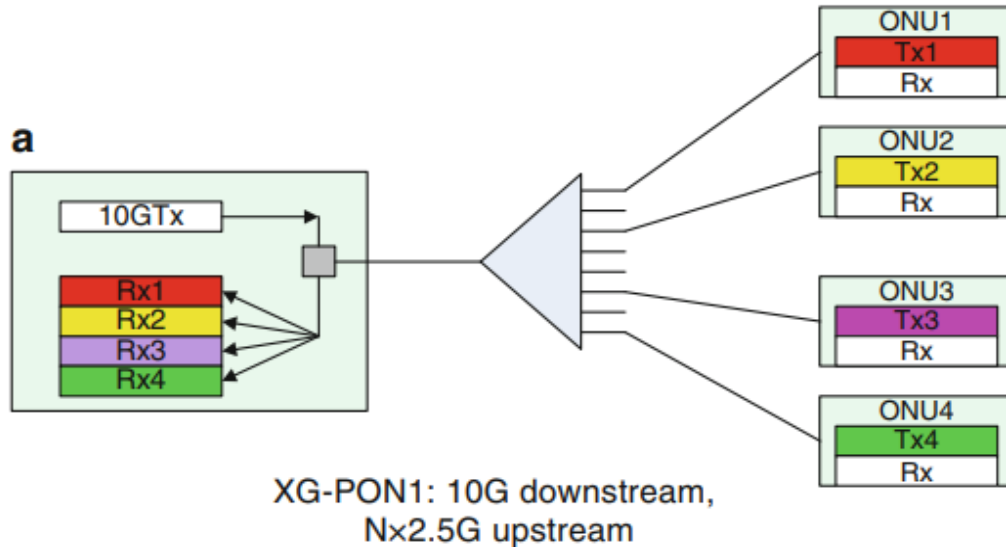

Figure 25: XGPON1

Reference: exfo_book_fttx-pon-technology-testing_en.pdf

Asymmetric 10G-PON

Asymmetric 10G-PON or XG-PON provides the downstream data rate of 9.95328 Gbps and the upstream data rate of 2.48832 Gbps.

In this, the upgraded bandwidth is 10Gbps for downstream link. In this architecture, the difficulty was the burst mode time division multiplexing access at 10 Gbps.

Due to this limitation when the rate goes beyond 5Gbps then the simple circuit designs become impractical. It requires huge investments of money to overcome this problem.

In order to minimize the problem, the solution was the upgraded architecture that will have only the downstream 10Gbps and one or more 2.5 Gbps upstream wavelength. This can be considered as TDM architecture. For the downstream 32 ONUs are using the 10Gbps link.

As per the number of upstream wavelengths available the ONUs in the upstream is divided into a different number of groups operating at 2.5Gbps. In the case of two wavelengths in the upstream, the ONUs are divided into two groups each virtual group has 16 ONUs sharing 2.5Gbps link.

Symmetric 10G-PON

Symmetric 10G-PON or XG-PON2 or XGSPON achieves 10Gbps in both the upstream and the downstream links. It requires cost inefficient burst mode transmitters at the ONUs for the upstream transmission. When there will be cost-effective 10Gbps burst mode commercially available then both the upstream and downstream with 10Gbps architecture can be used.

2. NG-PON2

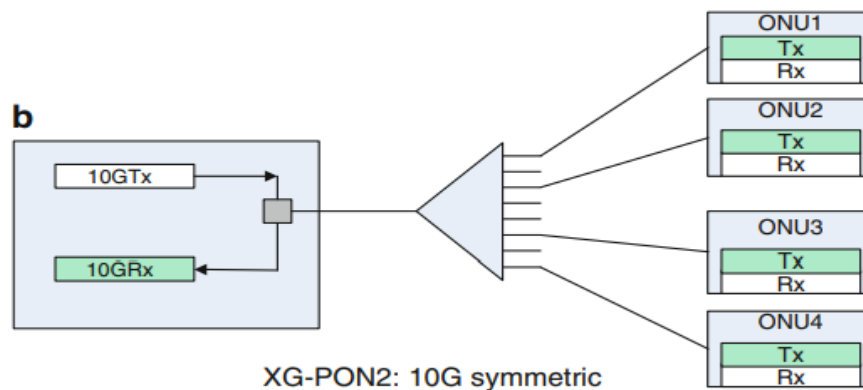

Figure 26: XGPON2

Figure 27: exfo_book_fttx-pon-technology-testing_en.pdf

On the other hand, NG-PON2 was provisioned by the new and independent PON system that is not limited by the GPON standards and deployed outside the plant.

2.3.1. C EPON (IEEE 802.3ah)

EPON or the Ethernet PON is based on the Ethernet technologies. It has many advantages such as:

1. It is scalable.
2. It is simple.
3. It has multicast convenience.
4. It has the capability of providing full-service access.

EPON has been deployed by China, Japan, Korea, and Taiwan. EPON is a point to multipoint technology with passive optical splitters.

It has optical fiber physical media dependent (PMD) sub layers that support this topology.

It is based upon multipoint control protocol (MPCP).

In this, it uses timers, the state machine to control access to point to multipoint.

The below diagram illustrates the Ethernet in access networks, MAN and WAN

Every ONU has an instance of MPCP protocol that communicates with the instance of MPCP in OLT. At the base level of the MPCP protocol, there is a point to point emulation sub layer. This sub layer at the MAC and the above layer shows the P2MP network as the point to point links. It is done by adding LLID (Logical link identification) at the beginning of two octets of the preamble. It adds a mechanism for network Operations, Administration (OAM) is to facilitate network operation and troubleshooting.

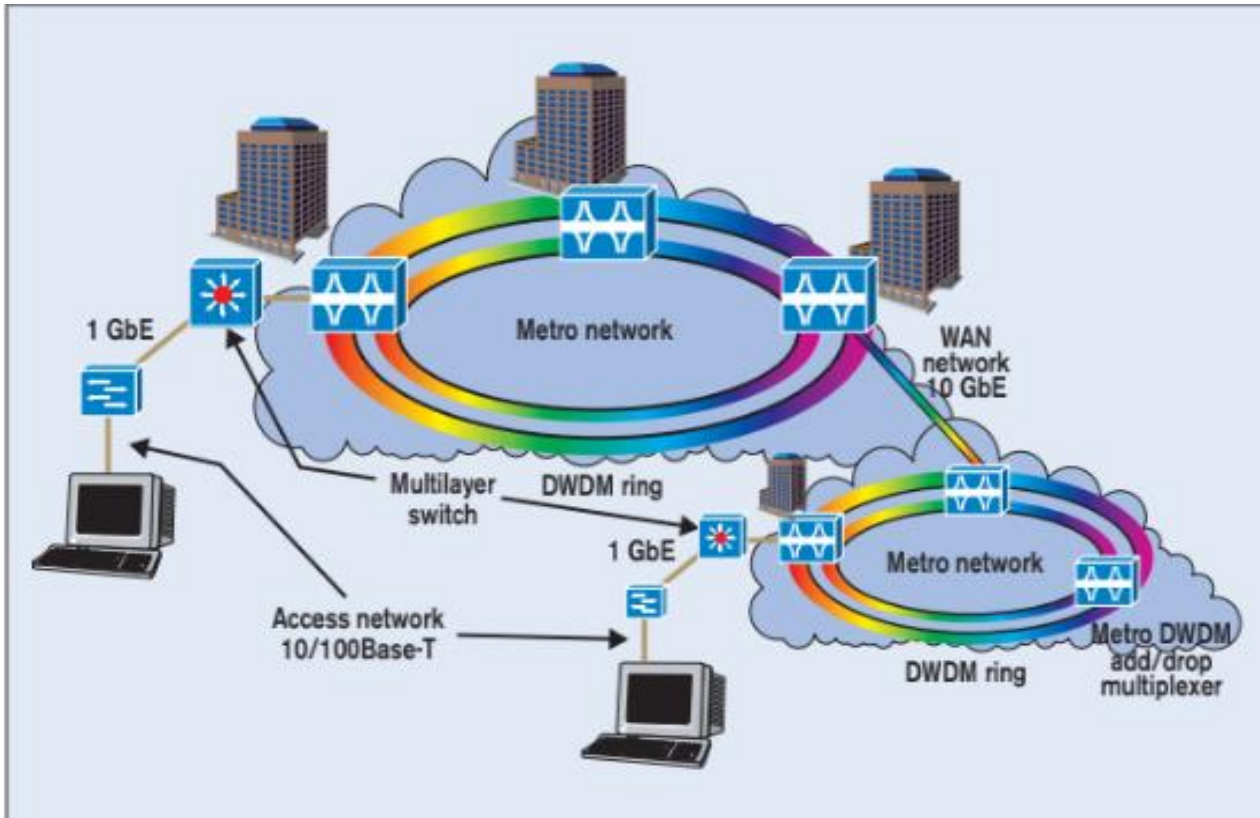

Figure 28: ETHERNET IN ACCESS NETWORK

Reference: exfo_book_fttx-pon-technology-testing_en.pdf

To the ONUs, the downstream traffic is continuously broadcasted. Every ONU keeps the packet that is for them and reject all other ONU's that are destined to rest of them.

For the upstream traffic, the time slot is allocated by the OLT when to transmit the packet by ONU. Multiple access protocol is used to combine upstream signal. Mostly, it uses time division multiple access (TDMA).

The OLT is responsible to range the ONUs so as to provide a time slot for upstream communications. Burst-mode transceiver is needed to satisfy the burst transmission in upstream from an ONU to the OLT.

In comparison with the GPON, the burst size transmission and physical layer overhead are large in EPON. So, there is no need for any protocol and circuitry to adjust the laser power in ONU's. Moreover, it has a higher bound of the laser-on and laser-off times at 512 ns. There is one more cost-effective quality of EPON that is to preserve the Ethernet framing format that carries variable length packets without fragmentation.

IMPORTANT DIFFERENCES BETWEEN GPON AND EPON

		GPON		EPON		
MAC Layer 2	Frame	Ethernet over GEM				
		ATM over GEM				
Ethernet/ATM over GEM						
	TDM Support	TDM over GEM		TDM over Packets		
PHY Layer 1	Distance (km)	10				
		20				
		Logical: 60				
	Split ratio			16		
		32 / EPON with FEC or DFB/APD				
		64 / 128 Logical and limited by IL				
	Bit rate (Mbit/s)	155.52	Downstream	Upstream	Downstream	Upstream
				X		
		622.08		X		
		1244.16	X		1000 Nominal	
	2488.32	X				
Line Coding		NRZ + Scrambling		8B/10B data stream		
Loss Budget (dB)			15			
			20			
			25			

Reference: exfo_fttx_pon_reference_guide_en.pdf

2.3.1. D 10GEPON

The two main focus of the 10G EPON by the IEEE 802.3av 10G-EPON was to meet the following demands:

1. They took the responsibility to increase the downstream bandwidth to 10 Gbps.
2. They will to also provide two upstream data rates that are 10 and 1 Gbps.
3. It specifies the reconciliation sub layer (RS), symmetric and asymmetric physical coding sub layers (PCSs), physical media attachments (PMAs), and physical media dependent (PMD) sub layers.

Every power budget has further three power budget classes:

1. Low power budget (PR(X)10)
2. Medium power budget (PR(X)20)
3. High power budget (PR(X)30).
4. PR(X)10 and PR(X)20 power budget classes are defined

The 1G-EPON has only:

1. 1 Gbps symmetric data rate
2. Uses 8B/10B line coding
3. Although this is optional: Reed-Solomon code (255, 239)

In comparison the 10GEPON has:

1. Symmetric 10 Gbps downstream and upstream respectively, it denotes PR as the power budget for symmetric-rate PHY of 10 Gbps both upstream and downstream.
2. Asymmetric 10 Gbps downstream and 1 Gbps upstream data rates, for asymmetric-rate PHY of 10 Gbps downstream and 1 Gbps upstream 10G-EPON denotes PRX as the power budget
3. 10G-EPON has 64B/66B line coding with that the bit-to-baud overhead is reduced to about almost 3%. To fulfill the need of optical transceivers, Reed-Solomon code (255, 223) is selected as the permanent forward error correction (FEC) code in 10GEPON to increase the FEC gain, while Reed-Solomon code (255, 239) is specified as optional for 1G-EPON.
4. There are advanced transmitters and higher launch power in 10G-EPON to assure sufficient signal-to-noise ratio (SNR) at the receiver side to recover the best of data with a rate of 10 Gbps. With the increased launch power, there should be an increase in the power consumption of the optical transmitter.
5. PR(X) 30 is the addition in two classes of 1G-EPON and it can support 32-split with a distance of at least 20 km.
6. For the FEC mechanism and increased line rate, the electronic circuit should have more functions and should process faster than that in 1G-EPON, hence lead to higher power consumption and possibly larger heat dissipation. So, for the accommodation of 10 Gbps in the physical layer, the power consumption of the OLT and the ONU may increase significantly.

To achieve the backward compatibility for the Mac and above layers, the operators of the network are encouraged to upgrade the service so there are some of the same features of the EPON in 10G-EPON that are:

1. Same Frame format
2. Same mac layer
3. Same Mac control layer
4. Same Network management system (NMS)
5. Same PON layer operations
6. Dynamic Bandwidth Allocation

2.3.2 WDM PON

Wavelength division multiplexing PON uses multiple wavelengths for the bandwidth allocation to the ONU's. There are a number of articles written on WDM, but it is not considered since it is costly. The solution to the NG-PON is the WDM PON in comparison with the 10G-EPON and NG-PON1 systems. For the high bandwidth fulfillment what WDM PON does is it provides every single subscriber with a wavelength in place of sharing wavelength between Thirty-two or more subscribers in TDM PON. In around 2006 year, WDM PON was deployed in Korea. However, due to the high costs as compared to EPON and GPON, the deployment of WDM PON in other countries was not considered to be the right step.

In comparison to the conventional TDM PON systems there are several advantages of the WDM PON architecture which are as follows:

1. In WDM PON every user has access to its dedicated one or more wavelengths, therefore this allows every subscriber to have the full bandwidth access.
2. WDM PON networks are more scalable and have better security since every home has access to its own wavelength.
3. There is a simplified MAC layer control in WDM PON because the connections between the OLT and the ONU in WDM PON is a point to point which does not require the Point-to-Multipoint (P2MP) media access, controllers.
4. In a WDM PON network, every wavelength is a point to point link which allows all the links to run at different speeds and with different protocols which provide maximum flexibility.

Even with all these features, WDM PON is still expensive due to the specific wavelength allocated to every ONU. Since every subscriber has its own dedicated wavelength OLT that can support 32 ONUs has to transmit 32 different wavelengths.

So, that means this wavelength specific feature is not that economic as it will even lead to the high requirement on lasers in comparison with the TDM PON if for every ONU there is need of the same kind of wavelength fixed lasers. The solution can be tunable laser so that can provide each ONU with a desired wavelength, but the problem again is that tunable laser is costly. So, these costly equipment's make it difficult to choose the WDM PON.

2.3.3 OFDM PON

OFDM PON is orthogonal frequency division multiplexing in this a number of orthogonal subcarriers are employed to and from the traffic of ONU's. OFDM is considered these days because of its high bandwidth facility.

OFDM has improved bandwidth with its advanced transmission capability. A large number of closely-spaced orthogonal subcarriers are used in OFDM to carry data traffic.

Every subcarrier is modulated by a conventional modulation scheme (such as quadrature amplitude modulation or phase-shift keying) at a low symbol rate, thus it achieves the sum of the rates that are given by all subcarriers compatible to those of conventional single-carrier modulation schemes in the same bandwidth. The duration of each symbol is relatively large since the data rate carried by each subcarrier is low.

Therefore, the inter-symbol interference in a wireless multipath channel can be reduced. The OFDM modulation scheme in the optical access network can increase the network provisioning data rate.

The OFDM is deployed in the following:

- ADSL
- DVB-T

- WLAN
- WiMAX
- 3GPP LTE

Moreover, instead of costly optical devices, the electronic devices that are used are cheaper. It is a tough competition in comparison with NG-PON2 as when combined with WDM can further increase the bandwidth.

ADVANTAGES OF OFDM PON

Following are the advantages of OFDM PON:

- **Effective use of spectral resources:** OFDM PON's orthogonal properties among the subcarriers allows the spectral overlap of individual sub channels. Simple constellation mapping algorithm for high-order modulation schemes.
- **Use cheaper electronic devices:** OFDM uses cheaper electronic devices and avoid costly optical devices. It uses DSP (Digital signal processors) of high speed and microwave devices of high-frequency.
- **Subcarriers are allocated dynamically:** Depending upon the scenario of channel and application the number of bits carried by each subcarrier is dynamically allocated. The subcarrier is allocated based upon distance, access service.
- **Combination of wired and wireless access:** OFDM supports access to baseband OFDM, WiMAX, Wi-Fi.
- **Improvement to long haul access network:** The simple the network will be it will reduce the costs as well as improve performance. Long distance optical fibers have suffered from the problems of the quality of service as the signal is degraded while reaching the final point. The OFDM modulation scheme help to reduce the dispersion. Therefore, OFDM-PON can be used for the long haul access with better service.

2.4 EVOLUTION OF PON

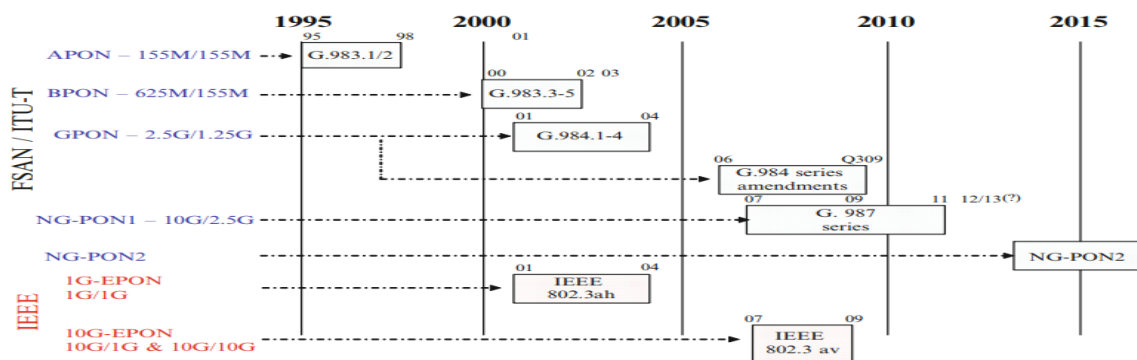

Figure 29: EVOLUTION OF PON

Reference: exfo_book_fttx-pon-technology-testing_en.pdf

2.5 PARTS OF PON:

For the understanding of PON, there are different structures to connect the subscribers, but the basic structure is somewhat the same. So, each PON has some of the same requirements which are as follows:

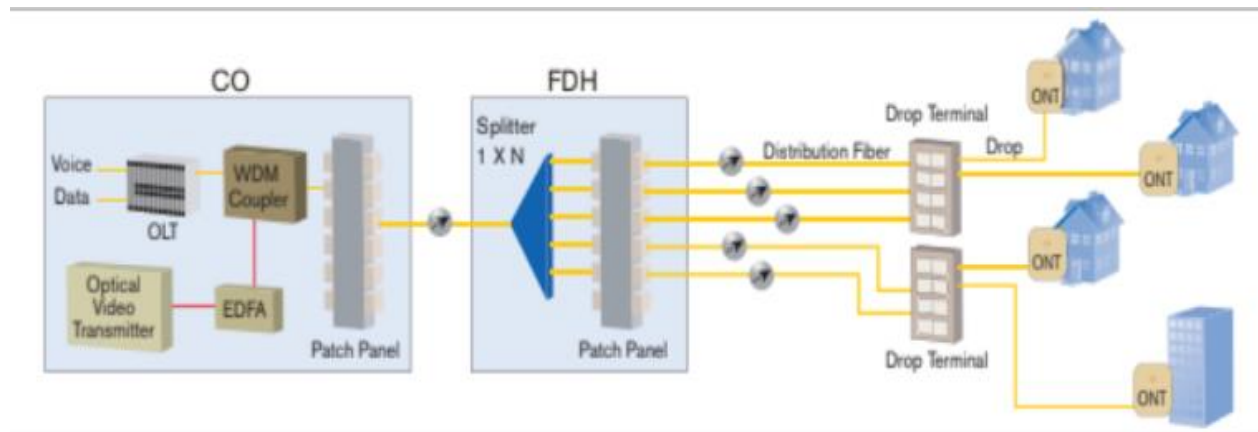

Figure 30: PARTS OF PON

Reference: exfo_fttx_pon_reference_guide_en.pdf

1. In P2MP and P2P PONs an OLT at CO
2. Video distribution equipment
3. A feeder fiber from the CO to a splitter in P2MP PONs
4. Distribution fibers and drop cables between the splitter branches and the optical network terminals (ONTs) (one distribution fiber/drop cable per ONT), the same feeder fiber (pair) in P2P PONs.
5. An ONT (ONU connected to the UNI) located at each subscriber's premises in P2MP and P2P PONs.

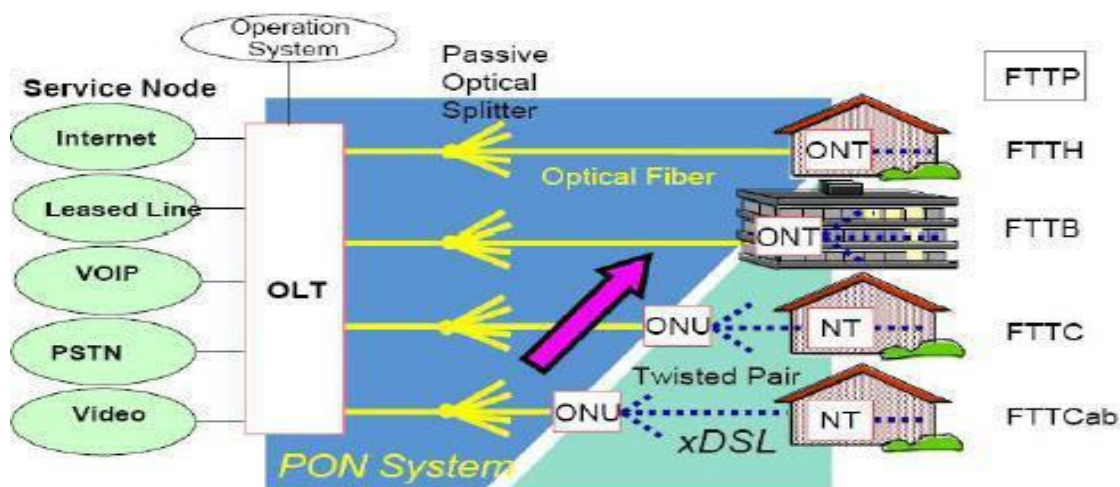

Figure 31: PON SYSTEM

<https://community.fs.com/blog/abc-of-pon-understanding-olt-onu-ont-and-odn.html>

Between the OLT and ONT, there are both the optical and non-optical components. ODN (Optical Distribution Network) is made up of all the optical components.

The optical components are:

- **Splices**

Fiber optic splicing is used in Telecommunications or LAN and networking projects. Fiber optic splicing is the process of joining two fiber optic cables together. Fiber splicing leads to lower light loss and back reflection than termination that makes it suitable method when the cable is too long for a single length of the fiber or when joining two different types of cable together, such as 48-fiber cable to four 12-fiber cables.

Generally, there are two methods of fiber optic splicing:

Fusion splicing

Mechanical splicing.

Traditional Fusion-Splice Terminations	Spooled Pre-Terminated Components
Positive Factors	Positive Factors
• Once the splices have been well performed, the network design is very stable	• More attractive for Brownfield situations
• Less connectors in the design, especially at intermediate points between the FDH patch panel and the ONT connector; therefore less chance of contamination or dirt accumulation—especially before construction has been completed	• Attractive proposition for situation where splicing crew is more expensive or hard to get
	• Increase the speed deployment of the project (less splicing time)
• Lower cost of components	• Decrease the cost of the labor in the project (less splicing fees)
	• Allow additional test connection points between the FDH patch panel and the connector at the ONT
Negative Factors	Negative Factors
• If splicing fees are expensive or splicing labor is hard to get for a particular project, this approach may be an issue	• Many connectors in the design, in addition to at the FDH patch panel location, can create dirt accumulation—especially before construction has been completed
• Does not provide intermediate test access point between the FDH patch panel and the ONT connector	• Increase in the cost of components
General Appreciation	General Appreciation
• De-facto approach: contractors are used to splice and the presence of connectors in non-hardened cabinet, especially when construction is not finished, can create a situation where the connector becomes contaminated and major cleaning or re-connectorization is required at some places	• This approach is obligated to provide evidence for its position. This is what the vendors are working on now and customers are listening. Interviewees have been open-minded and some have said that this approach must generate savings >20-30% to justify the use of this type of component

Reference: exfo_fttx_pon_reference_guide_en.pdf

- **Connectors**

A connector is an electro-mechanical device that is used to join electrical terminations and create an electrical circuit. Electrical connectors have:

- Plug(male-ended)
- jacks (female-ended)

- **WDM couplers**

WDM couplers are basically used for multiplexing and de-multiplexing.



Figure 32: WDM COUPLER

Reference: <https://www.google.co.in>

- **Fiber optic cables**

Fiber Optical cable is just like an electrical cable, but the difference is that optical cable contains one or more optical fibers which are used to carry light. The optical fibers are coated with plastic layers and these are contained in a protective tube suitable for the environment where the cable will be deployed.

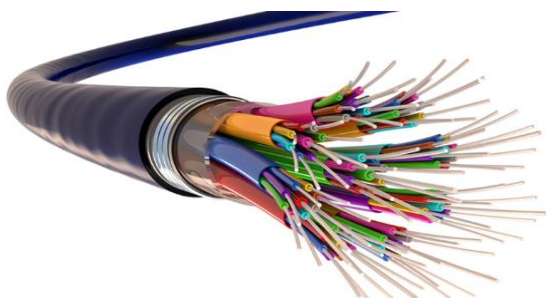

Figure 33: FIBER OPTIC CABLE

Reference: <http://www.peakoptical.com/2018/03/evolution-fiber-optic-communication/>

- **Patch Cords**

A patch cable, patch cord or patch lead is an electrical or optical cable that is used in connecting one electronic or optical device to another for purpose of signal routing. Patch cords come in a wide range of colors so they can be easily differentiated and are relatively short.

Types of patch cords include

- Microphone cables
- Headphone extension cables,
- XLR connector,
- Tiny Telephone (TT) connector,
- RCA connector



Figure 34: PATCH CORD

Reference: <http://pbp.com.pk/wp-content/uploads/2015/12/1241746070.jpg>

The non-optical components are:

- Pedestals
- Cabinets
- Patch Panels
- Splice Closures

2.6 PON IMPLEMENTATION

In an FTTH network, the installation of PON equipment can be done in many ways and each installation can be different, that depends upon factors such as the distance from the CO, residential density and distribution urbanism. Fiber-optic cables can be implemented using the most suitable aerial or underground installation techniques.

BELOW IS FTTH PON BASIC SYSTEM ARCHITECTURE

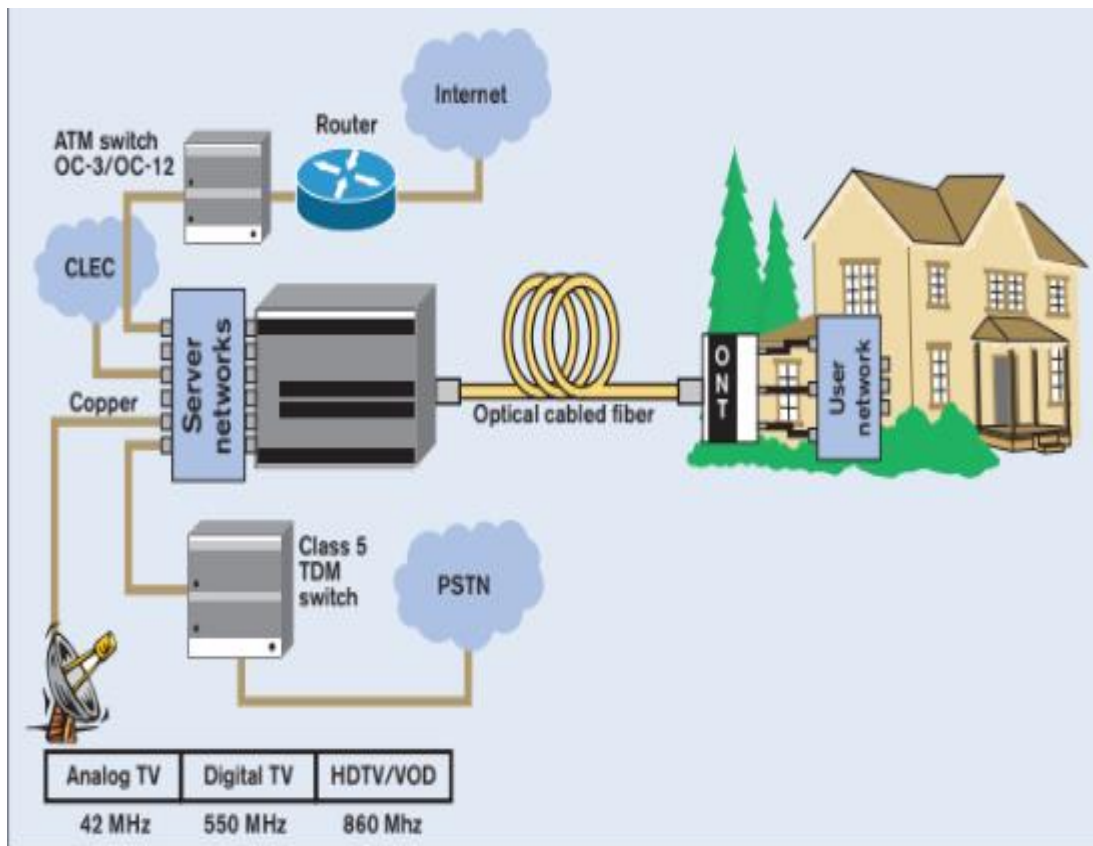

Figure 35: FTTH PON

Reference: exfo_book_fttx-pon-technology-testing_en.pdf

2.6.1 Fiber

One of the costliest installations in PON deployment is Fiber-optic cable. There are different methods available and the decision of method depends on various factors that include cost, right-of-way etc. and on if the installation is for new premises development or for existing development.

There are three basic cable-installation methods:

- **Direct Burial Method:** The direct burial method in which the cable is placed underground in direct contact with the soil.
- **Duct Installation:** A duct installation in an underground duct the optical cable is placed. In comparison with the direct burial installation the initial duct, installation is more expensive, but the use of ducts makes it much easier to increase or decrease the values of cables.
- **Aerial installations:** In this, the cable is placed on poles or towers above the ground. This is less costly than underground installation and does not require heavy machinery.

- For more populated areas there are other alternative methods available like installing the cable in grooves cut into the pavement or inside drainpipes.

2.6.2 Drop Terminals

Drop terminals are used for easy access to service connection, distribution and if used that can be aerial, underground or located in an apartment building. Cable drops between splitter and premises are sometimes pre-connected and can be buried or aerial-mounted.

2.7 The testing of PON Installation

The main motive of an optical network is to provide error-free and high-speed transmission. Appropriate testing during installation is important because of the following:

- Network guarantees that things meet specifications
- It reduces costly and time-consuming troubleshooting efforts by locating damaged connectors, splices and other faulty components before they ruin service.

The important factors to make sure that there is proper transmission is to control the power losses in the network against the link loss budget specifications from the ITU-T Recommendation and IEEE standard that is completed by making a total end-to-end loss budget with enough margin while reducing back reflections to a minimum.

Attenuation= Output Power/Input Power

When a device is used in a network assembly, the attenuation is called the “**insertion loss**” and it has negative value since the performance decreases.

2.7.1 The connection of the connector and how it is maintained

Connectors are most important components that are used connect the whole network elements, that is why keeping them in healthy condition is necessary to investigate, that all the equipment work to their maximum performance to reduce uncertain network failures

Due to the involvement of high power, it is most important to properly inspect and clean all connectors within the specifications.

Consider the following guidelines when making connections:

1. Unmated connectors should never be allowed to touch any surface, other than cleaning the connector ferrule should not be touched.
2. Firstly, you should inspect the connector end-face that whether it is clean or not, after cleaning it then inspect it again using a fiberscope or a video scope before mating although even if there was only a temporary disconnection.

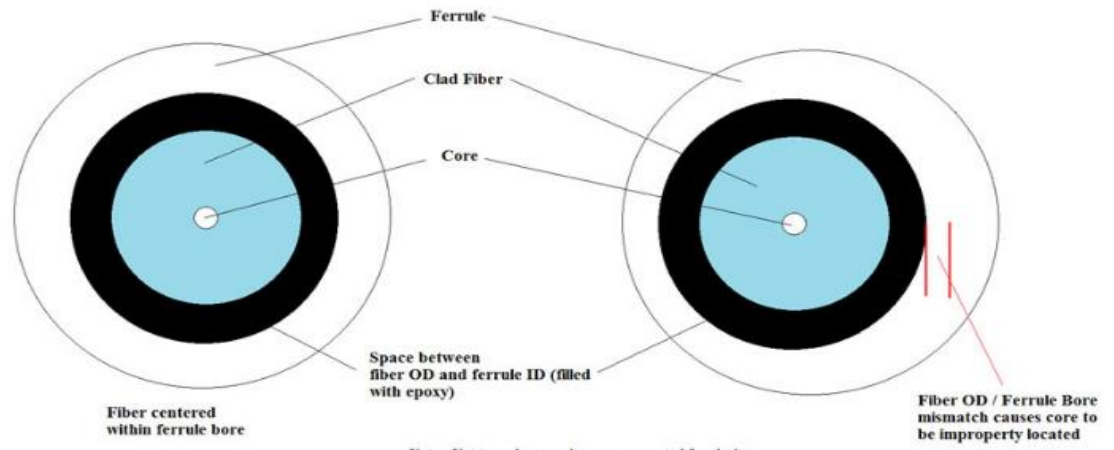

Figure 36: CONNECTOR END FACE

Reference: <https://www.cablinginstall.com/articles/print/volume-27/issue-2/features/special-report/good-fiber-optic-connections-start-with-the-ferrule.html>

3. Every time the instrument is used clean and inspect the test equipment connectors and then after cleaning using a fiberscope.

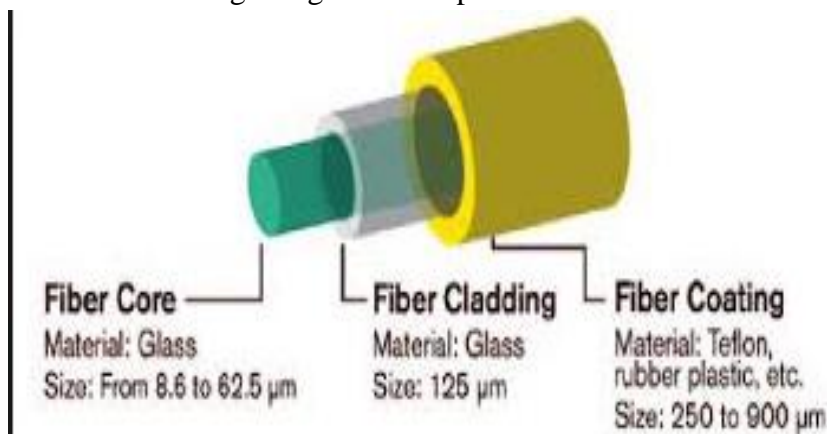
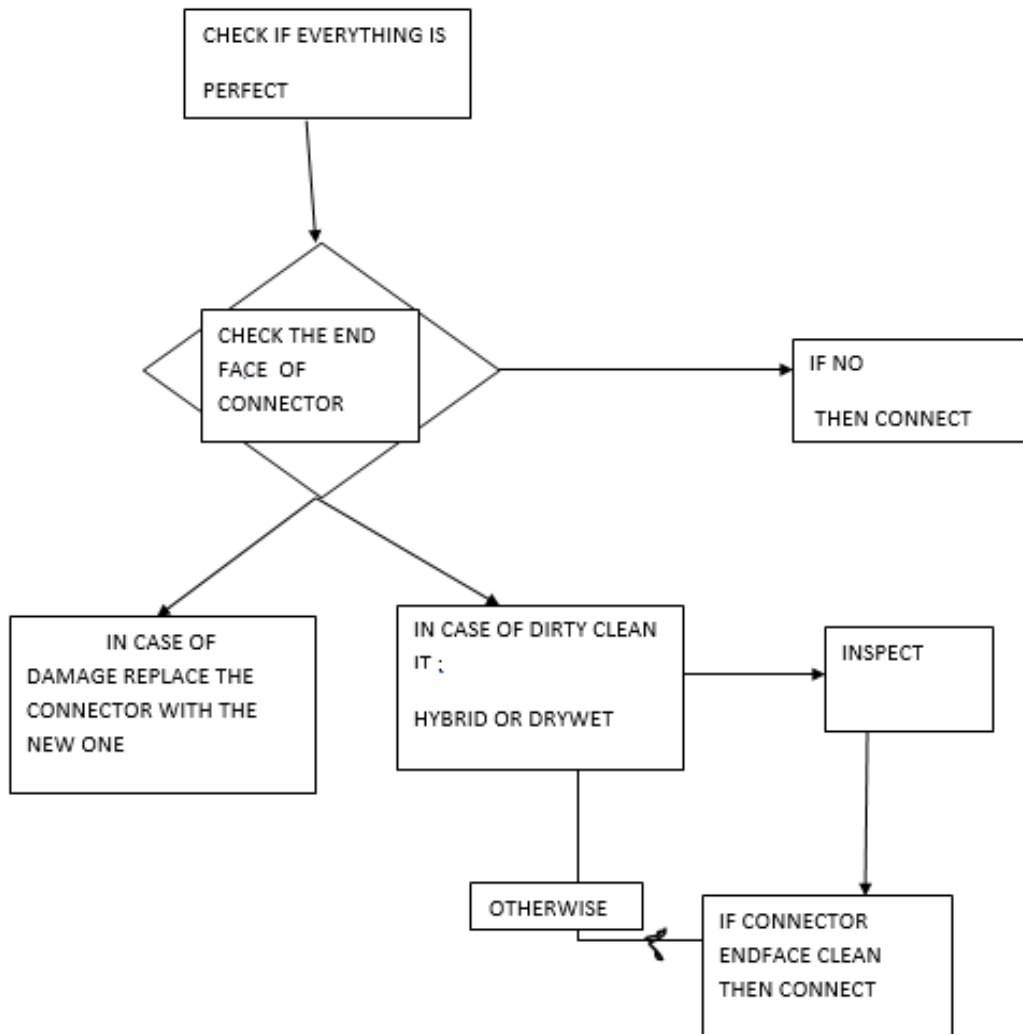

Figure 37: FIBER

Reference: https://www.testforce.com/testforce_files/Exfo-Connector-Guide.pdf

4. The cleaning method should be appropriate: dry or wet/dry. To do the dry or wet/dry cleaning, you can use the items like a tape, surface-cleaning pad, lint-free wipes, isopropyl alcohol (IPA).
5. The not used connector ports capped and unused cap can be kept in a small reseal able plastic bag.



2.7.2 IMPORTANT THINGS TO NOTICE WHILE THE TESTING

- Do not look with the naked eye into a live fiber. Always wear protective gear to inspect cable ends and connectors or use video scope.
- Always follow all safety procedures that are provided in the user guide.
- Without powering off do not ever look directly into fibers, connectors or equipment apertures, unless you are absolutely sure that the light source.
- Power off the fiberscope before using and use a video scope to inspect fiber ends and connectors.
- Never power up any laser-transmitter equipment unless you are sure that all the work has been completed.

2.8 ADVANTAGES OF USING PON

- Reduced fiber usage
- Dynamic bandwidth allocation
- Financial savings
- It has long reach operating at a distance over 20 Km.
- It allows upgrade to higher bit rates or additional wavelengths.

- There is less need for fiber installation in both the local exchange office and local loop.

CHAPTER-3

GPON

THE CONTENTS THAT WILL BE COVERED IN THIS CHAPTER:

1. WHAT IS GPON AND WHY IS IT USED
2. THE STANDARDS OF GPON
3. GPON NETWORK MODEL REFERENCE
4. THE FUNDAMENTALS OF GPON
5. THE FEATURES OF GPON
6. GPON FRAME FORMAT AND MULTIPLEXING
7. GPON TECHNIQUES
8. COMPONENTS OF GPON
9. GPON FTTH ARCHITECTURE
10. GPON NETWORK PROTECTION MODES
11. POWER BUDGET

3.1 WHAT IS GPON AND WHY IS IT USED

Gigabit Passive Optical Networks (GPON) is an Optical System completed by FSAN, for the Access Networks, based on ITU-T specifications G.984 series which includes management, control, physical and transmission convergence layer and the architecture. GPON is the choice of large carriers in the International market. It is more cost effective than BPON and EPON.

There are various bit rates that are supported by the GPON:

	UPSTREAM	DOWNSTREAM
BITRATES	155 Mbps	1.24416 Gbps
BITRATES	622 Mbps	1.24416 Gbps
BITRATES	1.24416 Gbps	1.24416 Gbps
BITRATES	155Mbps	2.48832 Gbps
BITRATES	622 Mbps	2.48832 Gbps
BITRATES	1.24416 Gbps	2.48832 Gbps
BITRATES	2.48832 Gbps	2.48832 Gbps

The combination that is widely used is the one highlighted above.

WHY IS GPON USED?

A 20 km reach can be provided GPON with a 28dB optical budget by using class B+ optics with 1:32 split ratio. There are different equipment's like OLT, ONU, and ONT for GPON,

which are the new generation PON equipment's and mainly applied by telecommunication operators in the FTTH project. The following table shows the growth of the graph by using the fiber-based GPON:

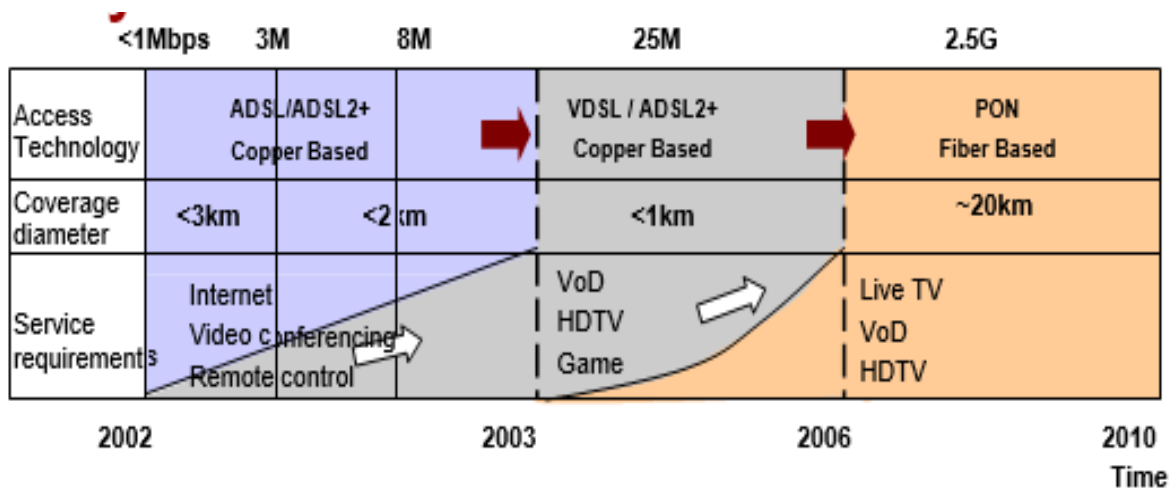

Figure 38: GROWTH WITH GPON

Reference: <https://www.slideshare.net>

3.2 THE STANDARDS OF GPON

There are in total of four standards of GPON which are as follows:

I. ITU-T G.984.1

- It defines the parameters of the GPON network.
- There is protection switch-over networking requirement.

II. ITU-T G.984.2

- ❖ The ODN (Optical Distribution Network) parameters are defined.
- ❖ The 2.488 Gbps optical port that is used in downstream and 1.244 Gbps that is used in upstream is defined.
- ❖ At the physical layer, the overhead is allocated.

III. ITU-T G.984.3

- ❖ The transmission convergence (TC) layer is specified in GPON
- ❖ It specifies GTC multiplexing architecture, protocol stack, GTC frame, ONU registration, ONU activation, DBA, alarms, and performance.

IV. ITU-T G.984.4

- ❖ It specifies the OMCI message format, a device management frame, working principle.

3.3 GPON NETWORK MODEL REFERENCE

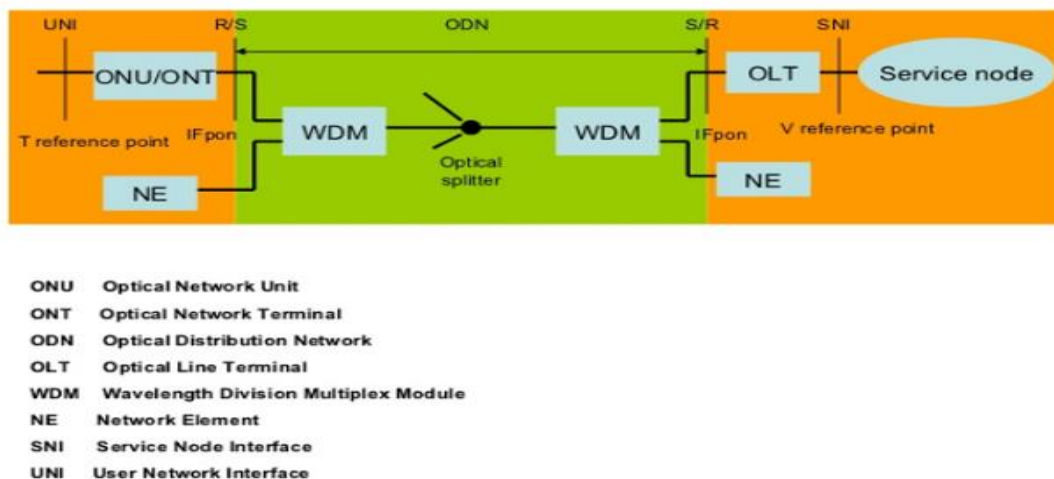

Figure 39: GPON REFERENCE MODEL

Reference: https://www.slideshare.net/Truong_RFD/35992488-gponfundamentals20070606a

3.4 THE FUNDAMENTALS OF GPON

Optical Line Termination (OLT) and Optical Network Unit (ONU) are the only Active transmission equipment in the GPON network. The different FTTx options with the logical network layout are as follows:

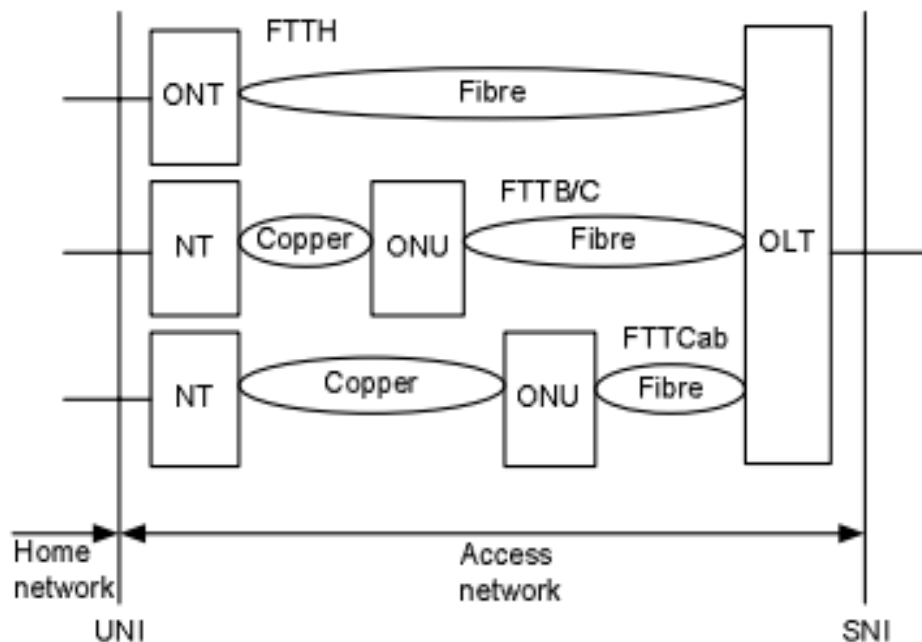

Figure 40: FTTx OPTIONS

Reference: https://fenix.tecnico.ulisboa.pt/downloadFile/3779576267480/12_GPON_%252520Information%252520Technology%252520Interfaces,%2525202007.%252520ITI%2525202007.%25252029th%252520International%252520Conference%252520on.pdf

There is only one single-mode optical fiber strand from the central office that runs till the passive optical power splitter which is located near users' locations. When this optical fiber reaches the splitter, the splitting device divides the optical power into N separate paths to the users. The splitting paths number may vary between the ranges of 2 to 64. So, individual single-mode fiber strand runs to each subscriber from this optical splitter. The maximum distance from the central office to an individual subscriber can be up to 20 km.

3.5 THE FEATURES OF GPON

- I. It supports Triple Play services.
- II. It provides easy access to high bandwidth transmission over twisted pair cables.
- III. It decreases the nodes of the network.
- IV. The operating wavelength range is as follows:
 - a. For the Downstream direction: 1480-1500nm
 - b. For upstream direction: 1260-1360.
 - c. For downstream RF video distribution: 1550-1560 nm
- V. To increase the reliability of the GPON networks the protection architecture can be implemented. It is considered an option and can be chosen on the basis of economic systems. The protection switching is of two types:
 1. Automatic switching: It comes into action when there is any detection of fault like frame loss, signal loss.
 2. Forced switching: It comes into action during the administrative works like replacement or rerouting of fiber.

3.6 GPON FRAME FORMAT AND MULTIPLEXING

GPON uses Wavelength Division Multiplexing (WDM) that has the facility of bidirectional communication over single optical fiber.

A PON network is divided into virtual connections for service multiplexing by GPON encapsulation mode (GEM) ports and transmission containers (T-CONTs).

For the segregation of upstream and downstream signals of several users over single optical fiber GPON uses two types of multiplexing:

1. For the downstream traffic, it uses the Broadcast Mechanism.
2. For the upstream traffic data is transmitted using TDMA.

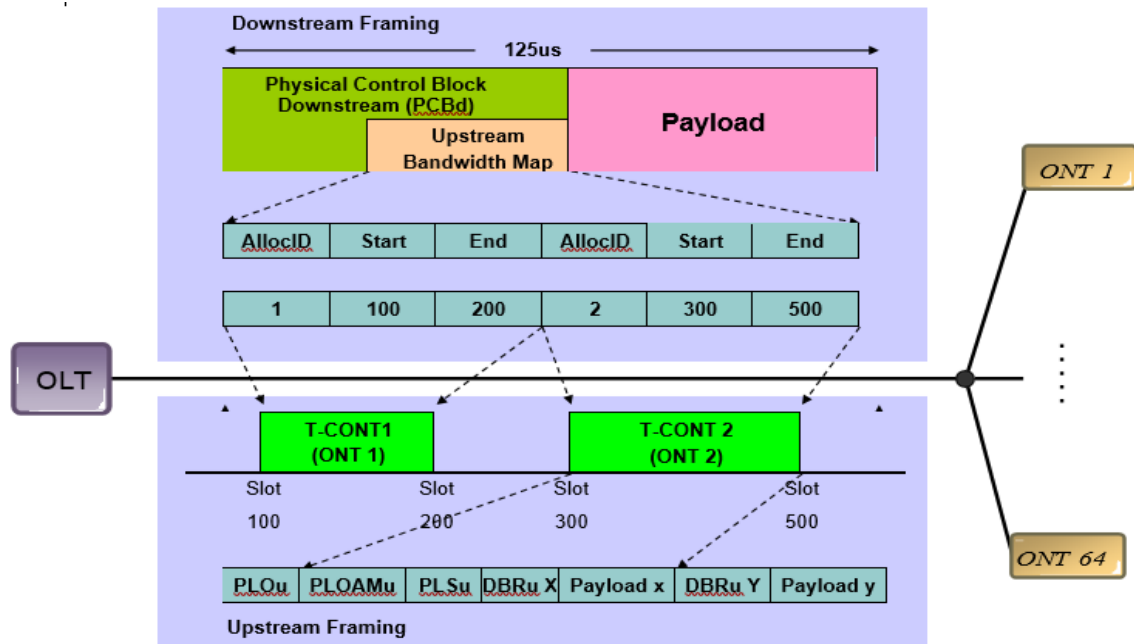

Figure 41: GPON FRAME FORMAT

Reference: <https://www.slideshare.net>

3.6.1 (FROM ONU/ONT TOWARDS OLT): UPSTREAM TRAFFIC

The network of GPON mainly consists of the following three components:

1. OLT
2. ONU
3. SPLITTER

GPON can transmit by using Ethernet, TDMA (Time Division Multiplexing), and ATM traffic. TDMA is used for the upstream traffic which is done under the control of OLT that is located at Central Office. OLT assigns the time slots of variable lengths to each ONU to make sure there is a synchronized flow of bursts of data. There are multiple transmission bursts in this. Each one of them will have:

- a) PLOu: Physical Layer Overhead
- b) PLOAMu: Physical Layer Operations, Administration and Management upstream
- c) PLSu: Power Leveling Sequence upstream
- d) DBRu: Dynamic Bandwidth Report upstream

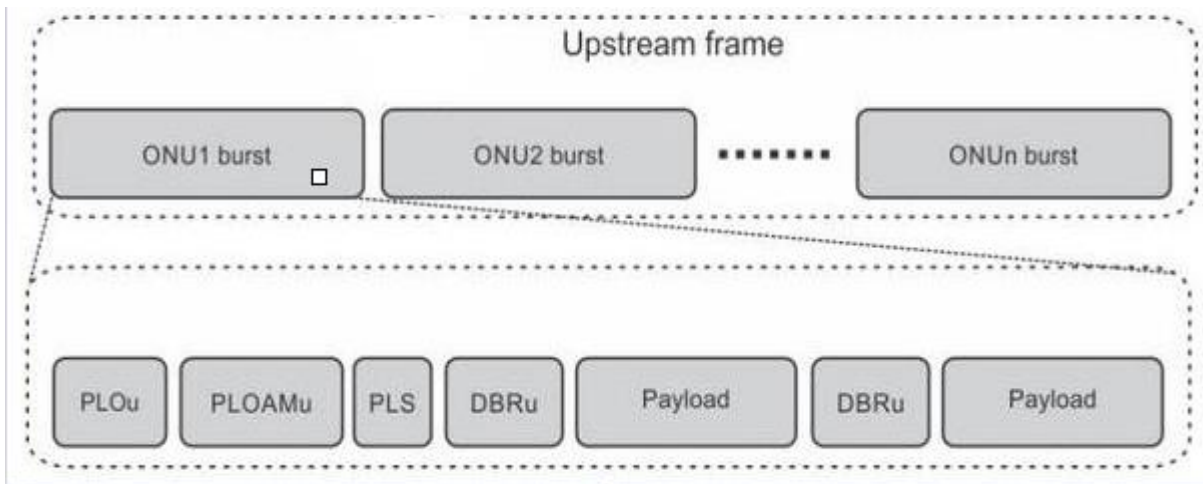

Figure 42: UPSTREAM FRAME

Reference: <http://www.sopto.com/st/ftth-knowledge/upstream-transmission-in-gpon>

The frame length is similar for all the rates as in the downstream. From the ONU every frame may contain one or several transmissions which are dictated with the help of the BW map. In the allocation period as per the control of the OLT, the one to four types of PON overheads and user data can be sent from ONU.

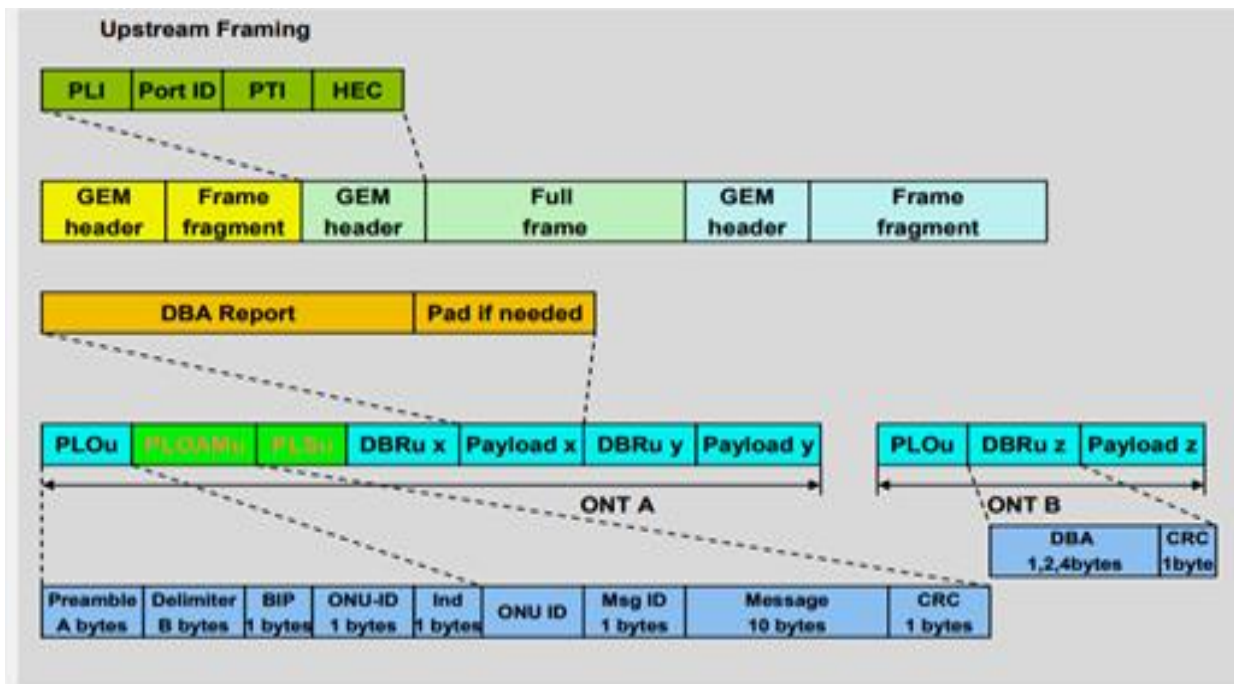

Figure 43: UPSTREAM FRAMING

http://jm.telecoms.free.fr/QCM_Fibre/GPON-Fundamentals_Huawei.pdf

The optical splitter is used to divide the signal upon need. From ONUs through the splitter the OLT takes in the optical signals in the form of beams of light and will convert it to an electrical signal. OLTs generally can support up till 72 ports.

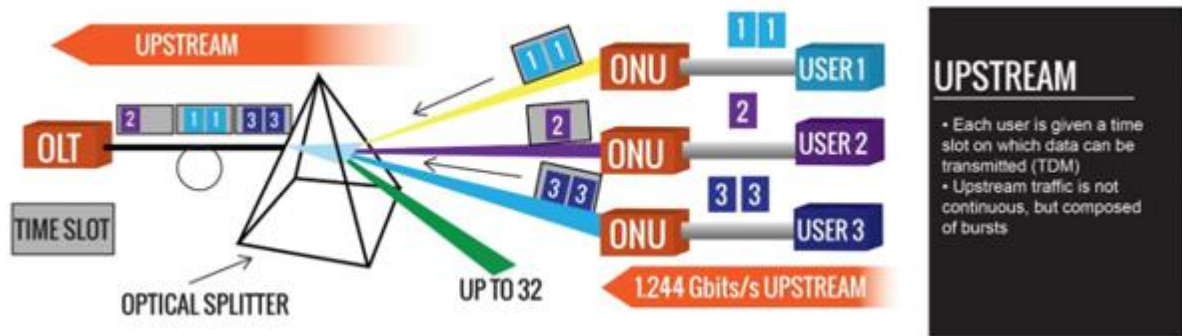

Figure 44: UPSTREAM

Reference: <http://www.gpon.com/how-gpon-works>

3.6.2 FROM OLT TO ONU: DOWNSTREAM TRAFFIC

From the OLT to all ONUs the downstream traffic is broadcasted in a TDM manner. Each ONU can only consider its own frames that are assured by the encryption.

The downstream frame has the following elements:

1. Physical control block downstream (PCBd)
2. ATM partition
3. GEM partition
4. The same time reference as for the PON
5. Same control signaling as for the upstream.

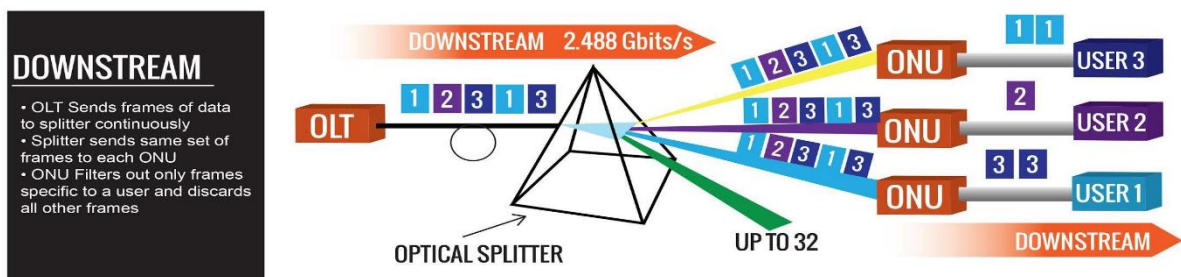

Figure 45: DOWNSTREAM

Reference: <http://www.gpon.com/how-gpon-works>

Even if there is no data to send still downstream frame will be transmitted for the purpose of time synchronization.

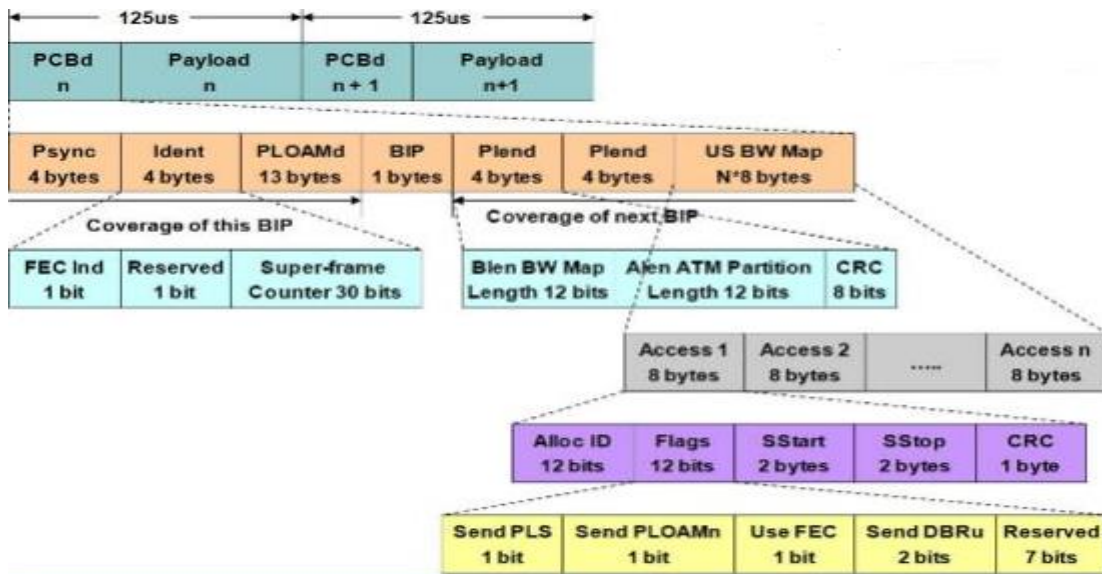

Figure 46: FRAME FORMAT

Reference: http://jm.telecoms.free.fr/QCM_Fibre/GPON-Fundamentals_Huawei.pdf

From a central office, a single mode optical fiber is transmitted to the optical splitter that is located near the users. This splitter will divide power into multiple individual optical line paths that vary between two to sixty-four that will run directly to the end users. This maximum distance from the CO to the user can be 20 km. For GPON in which the downstream transmission is broadcast and upstream is TDMA manner there can be different bit rates are possible but the most commonly used is with the upstream it is 1.2 Gbps and in the downstream is 2.4 Gbps.

MULTIPLEXING

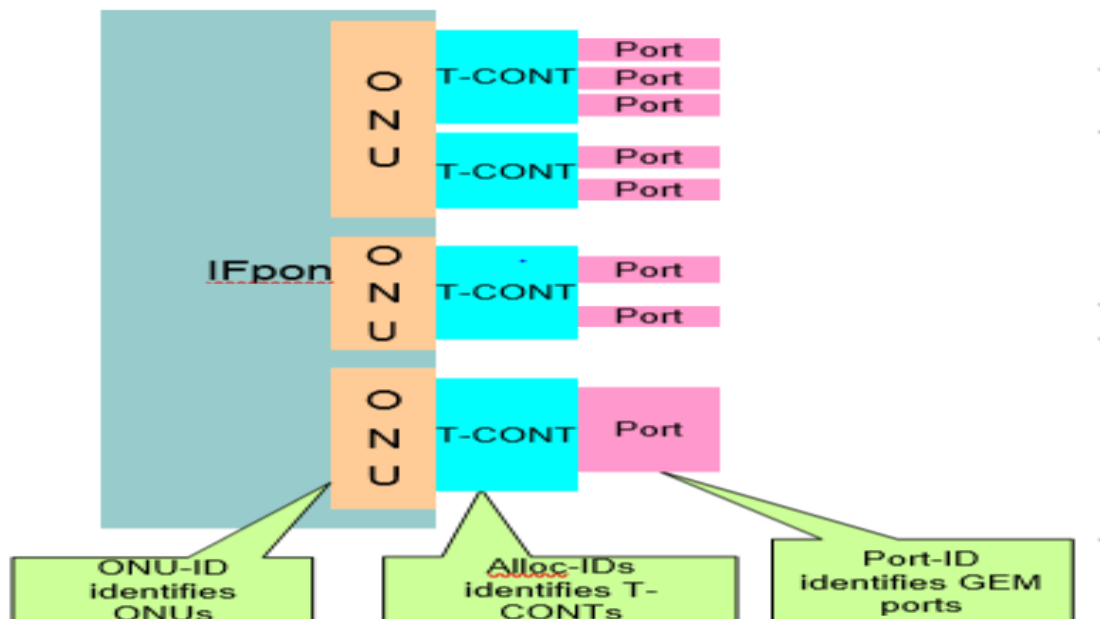

Figure 47: MULTIPLEXING

3.6.3 GEM (GPON Encapsulation Method)

Two methods of encapsulation are supported by GPON:

1. ATM
2. GPON encapsulation method (GEM)

All the traffic with help of the GEM is mapped across the GPON network using a variant of SONET/SDH generic framing procedure (GFP). The data over GPON is encapsulated by GEM and it provides connection-oriented communication. Any sort of data can be encapsulated, it depends on the situation. By using GEM Ethernet frames of variable length are transmitted in fragments. At the receiver side, the Ethernet frames can be reassembled. ITU-T recommendation G.7041 Generic framing procedure specifies GEM. For the voice, data, and video it uses ATM, Ethernet, and encapsulation respectively. The maximum downstream rate supported by GPON is 2.5 Gbps and the upstream rate varies from 155 Mbits/sec to 2.5 Gbps. Every port of GEM can carry single or several types of service stream. Before upstream service scheduling, a GEM port must be mapped to a T-CONT after carrying service streams.

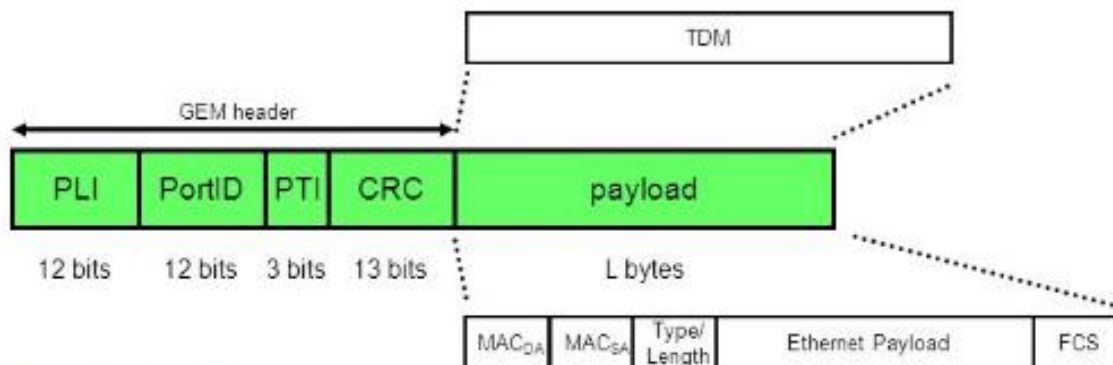

Figure 48: GEM FRAME

GEM provides the following features:

- For the Quality of service of the delayed traffic, it does frame segmentation.
- It provides efficient traffic
- It uses blocks of fixed lengths and 48 bytes is the default length.

At the sublayer level, GPON transmission convergence (GTC) framing is part of the GPON transmission convergence (TC) layer that recognizes the framing and delineation of each data portion.

3.6.4 SERVICE MAPPING UPSTREAM

In the case of the upstream transmission, based upon the rules between the service and GEM ports the ONU will send the Ethernet frames to GEM. When the GEM ports receive these Ethernet frames then they encapsulate these frames into GEM PDU (Packet data unit) after that, these are added to the TCONT queues which depend upon the mapping rules between GEM ports and T-CONT. The T-CONT then uses timeslots to send the GEM PDUs to the OLT for the upstream transmission. The GEM PDUs are received by the OLT and OLT will obtain Ethernet frames from PDUs. After that, the OLT will send Ethernet frames from the specified uplink port on the basis of mapping rules between service and uplink ports.

DOWNSTREAM

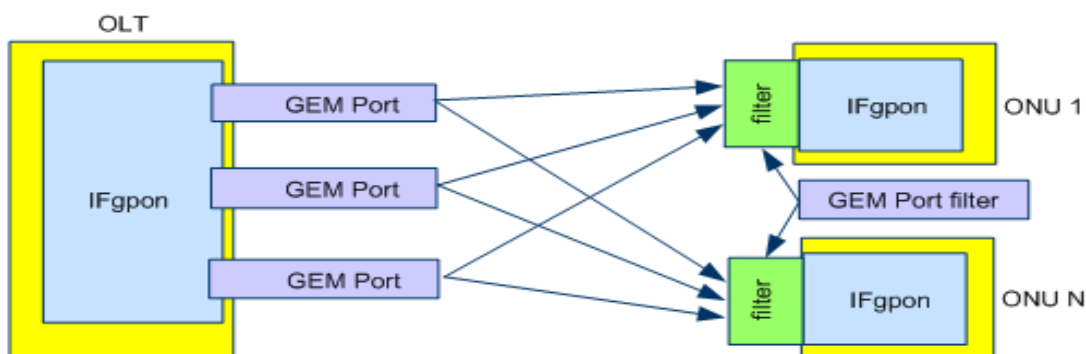

Figure 49: GEM DOWNSTREAM

<https://jornathunderlinkcom.wordpress.com/2016/05/04/gpon-service-multiplexing/>

For the downstream transmission, the OLT on the basis of the mapping rules between service and uplink port will send Ethernet frames to the GPON service processing module. Then, this GPON service processing module will encapsulate the Ethernet frames into GEM PDUs for the downstream transmission using a GPON port. All ONUs that are connected to the GPON port receives the broadcasted GPON Transmission Convergence (GTC) frames containing GEM PDUs. When the ONU receives the frames, it will filter the received frames on the basis of GEM port ID present in the GEM PDU header and only that ONU retains the data to the GEM ports of the ONU which has the same port ID. Finally, the ONU will de-capsulate the data to Ethernet frames and send these Ethernet frames to end users using service ports.

3.6.5 T-CONT

T-CONT is a PON-layer method that is used for upstream QoS. The bandwidth to usage by an individual ONU depends on the traffic scenario at ONU and traffic pattern at other ONUs in the network too in case of upstream. We know that the medium used by all the ONUs is shared so if any ONU will try self-transfer in the upstream direction it would lead collision and retransmission which will result in degraded performance.

So, between an ONU and an OLT, the shared media is made to behave like it is multiple point-to-point connections with the use of TDMA. At the central office, the OLT knows about the bandwidth demand at each ONU. With respect to the downstream frame, based on the traffic of each ONU a fixed slot is granted to each one. A T-CONT can be associated with single or

multiple GEM ports it depends on customer's data. The frame for upstream traffic can be divided into several container types. These are of five types in GPON which are as follows:

1. Type-1 T-CONT: It is one in which the periodic permit is granted for fixed payload allocation or for providing fixed bandwidth requirements. It is a static T-CONT type which is not serviced by DBA.
2. Type-2 T-CONT: This is used where there is bounded delay and jitter requirements and has a variable bit rate for them like video and voice over IP.
3. Type-3 T-CONT: This is where there is meant to be a guaranteed delay.
4. Type-4 T-CONT: It is for best effort traffic.
5. Type-5 T-CONT: It combines two or more of four types defined above and the bandwidth reporting and assignment is done at the ONU.

A Transmission Container (T-CONT) is an ONU object representing a group of logical connections. For the upstream bandwidth to be assigned on PON it appears as a single entity. On the basis of the mapping scheme, the traffic is first carried to GEM ports and then to the T-CONTs.

The mapping between the GEM port and the T-CONT is flexible. A GEM Port can correspond to a T-CONT, or multiple GEM Ports can correspond to the same T-CONT.

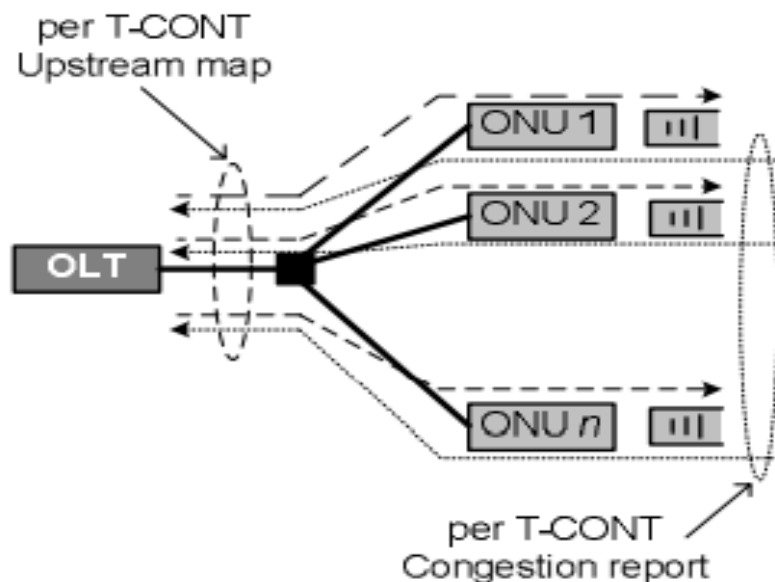

Figure 50: TCONT

Reference: <https://fenix.tecnico.ulisboa.pt>

3.7 GPON TECHNIQUES

The GPON techniques are of following types:

1. Ranging

The ranging is the GPON technique is required since the logic that reaches from ONUs to OLT vary so the time that is required to transmit the optical signal and to receive it by the ONU is different. Depending upon the environment the round trip delays (RTDs) varies between an OLT and ONUs. So, there may be collisions when different ONU sends data in TDMA mode. For this purpose, to prevent the data conflict between the OLT and ONU, the OLT must measure the distances between itself and each ONU to timeslot for converged upstream data. This is the way that time is controlled by OLT for each ONU to send data upstream.

For this process to take place the following steps are done:

The OLT has to obtain the round-trip delay (RTD) of the ONU it can be done by registering the OLT for the first time so it starts ranging for an ONU. On the basis of the RTD, the physical reach of ONU is calculated by OLT. On the basis of the physical reach, the proper equalization delay (EqD) is specified by OLT.

There is a requirement of the quiet zone by the OLT in order to pause the upstream transmissions of other ONUs during the ranging. This is done by emptying the BW map.

2. Burst optical or electrical technology

TDMA is used for the upstream traffic which is done under the control of OLT that is located at Central Office. OLT assigns the time slots of variable lengths to each ONU to make sure there is a synchronized flow of bursts of data. There are multiple transmission bursts in this.

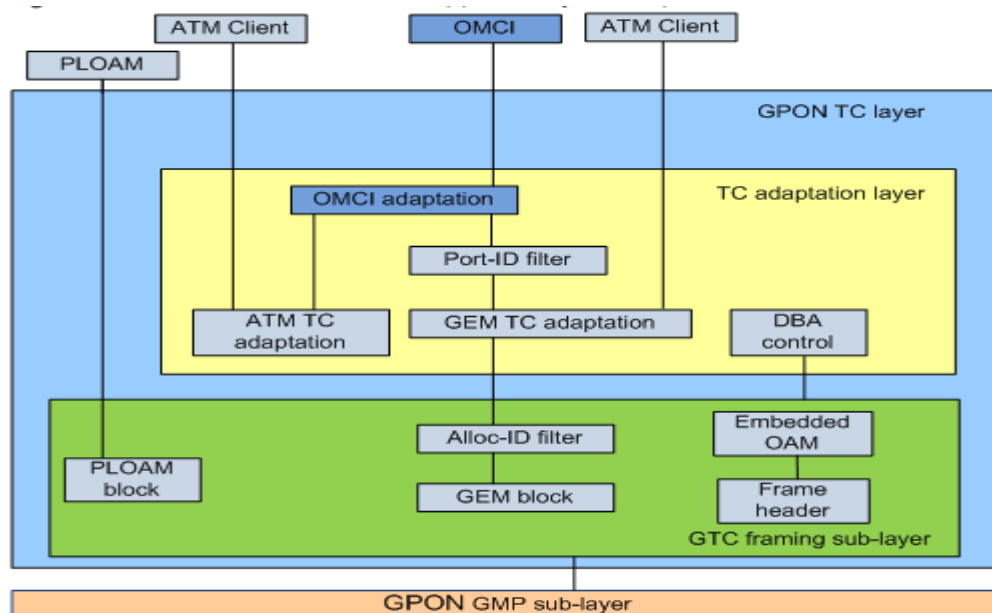

Figure 51: GPON LAYERS

3. DBA

DBA Operation Modes on ONU

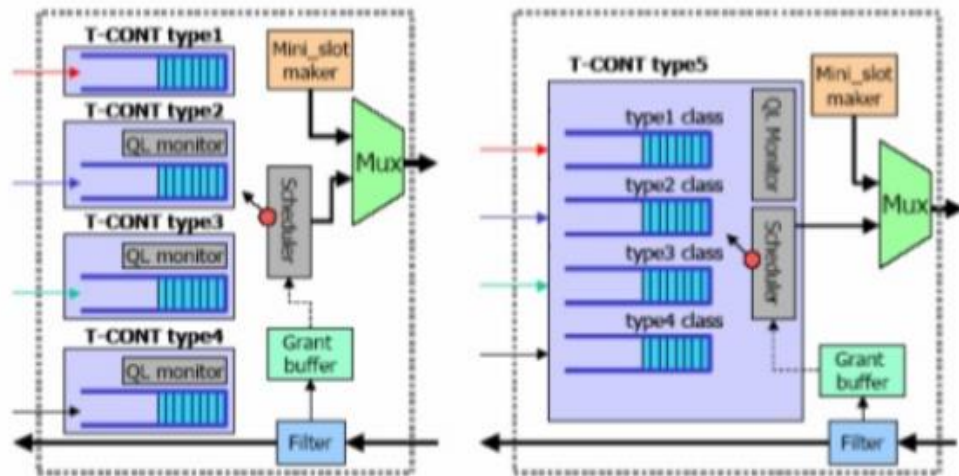

Figure 52: DBA OPERATION MODES

Reference:<https://support.huawei.com/enterprise/en/doc/EDOC1000078313?section=j00b&topicName=omci>

Dynamic bandwidth allocation (DBA) is the one that allows faster allocation of user's bandwidth depending upon present traffic requirements. OLT controls the DBA and allocates bandwidth to ONUs. DBA only works in upstream direction but for downstream, the traffic is broadcasted.

The OLT has to know the status of traffic of the T-CONT (Transmission container) related to the ONU in order to determine the amount of traffic to be assigned to ONU.

A T-CONT in the traffic status will also indicate how many packets are waiting in its buffer to give the information about it so that OLT can reapportion the grants to various ONUs according to it.

In case, ONU will find that it does not have any data waiting to be transmitted upon receiving a grant it will send an idle cell upstream to indicate that its buffer is empty.

This is sent to inform the OLT that the grants sent for that T-CONT can be assigned to other T-CONTs.

Multiple T-CONTs can be assigned to the ONU by the OLT when the long queue is waiting in the buffer for an ONU.

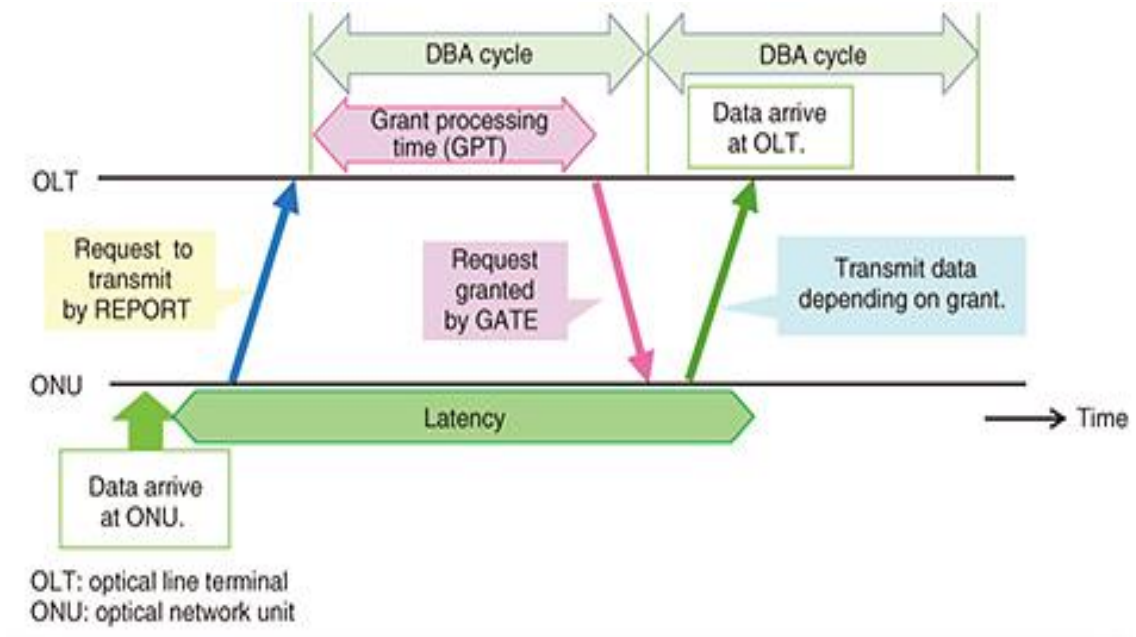

Figure 53: DBA CYCLES

Reference: https://www.slideshare.net/mansoor_gr8/gpon-fundamentals-8894877

4. FEC

Forward Error Correction (FEC) as the name suggests is a signal-processing technique that is used to detect and correct errors by encoding data. In this, along with the original information the redundant information is also transmitted. FEC does not have much overhead as the amount of redundant information is small. The link budget is increased approximately by 3-4dB. So, supports higher bit rate and long distance from the OLT to the ONU.

5. Line encryption

GPON basic function works as follows:

To all ONUs, the downstream data is broadcasted and each ONU has its allocated timeslot when data will be transmitted to it. So, the data belonging to ONUs that are connected to the same OLT can be captured by any malicious user who can reprogram his own ONU to it.

On the other, hand in case of upstream direction GPON has a point-to-point connection so all traffic is secured. So, the information like security key that is important and confidential can be sent in clear text.

Therefore, the GPONs G.984.3 has an information security mechanism that ensures that each user can have access to only the data that is intended for it.

The algorithm used for encryption is the Advanced Encryption Standard (AES). It accepts keys of 128, 192, and 256 bytes that ensures the difficulty of encryption. To enhance the level of security the key can be changed periodically without disturbing the information flow.

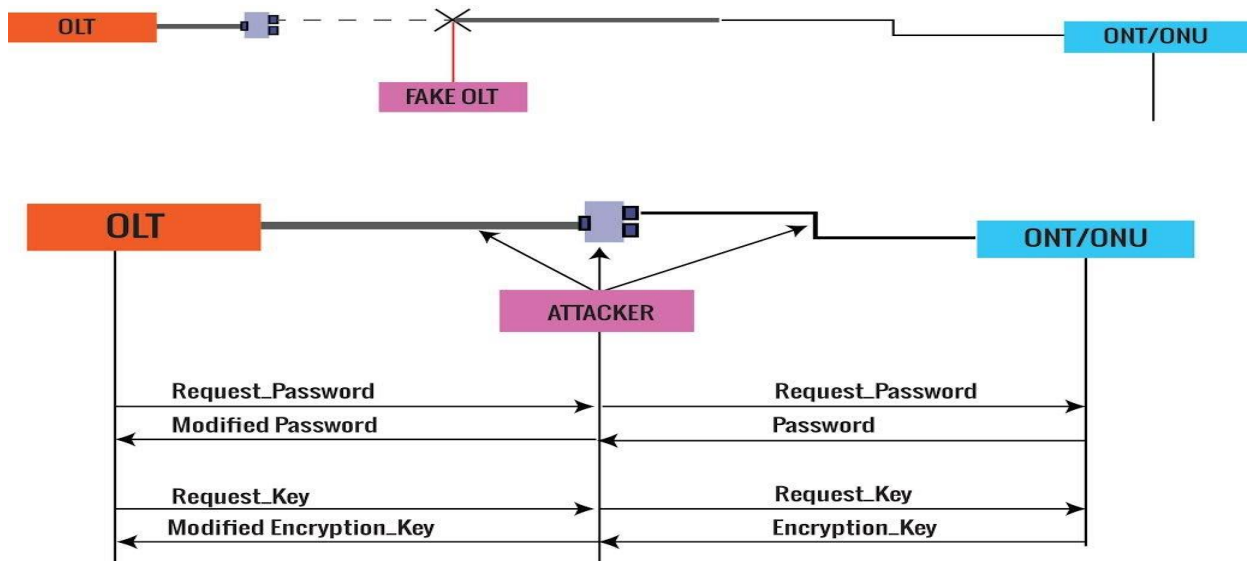

Figure 54: AES

Reference: <http://www.gpon.com/gpon-security>

3.8 COMPONENTS OF GPON

3.8.1 OLT (Optical Line Terminal)

The service node interface (SNI) of 1 Gbps or 10 Gbps interface is provided by the OLT to the core network. The GPON is controlled by OLT. There are three most important parts of OLT which are, Service port interface function, Cross-connect function, and Optical distribution network (ODN) interface.

The information going in both the directions through ODN is controlled by the OLT and this is the main function performed by OLT. OLT has two float directions:

1. Upstream:

From the users, the different type of data and voice traffic is provided to OLT. The OLT provides an upstream bandwidth allocation opportunity to the traffic bearing entities in ONU. The bandwidth allocated to the ONU is recognized by the allocation IDs (Alloc-IDs) which is a 12-bit number. It is assigned by the OLT to an ONU for the identification of a traffic-bearing entity. As per the specification by the OLT in the bandwidth maps, that is transmitted downstream, the bandwidth allocations to different alloc-IDs are multiplexed in time. In bandwidth allocation, the GEM Port-ID is used by ONU as a multiplexing key for the identification of the GEM frames that are of upstream logical connections.

2. Downstream:

It is receiving data, voice and video traffic from OLT to ONU. The multiplexing functions are done in OLT. A GEM Port-ID of a 12-bit number is assigned by the OLT to every single logical connection. Every ONU filters downstream GEM frames on basis of their GEM Port-IDs and only consider the one that belongs to the particular ONU.

At the local exchange, the OLT is provided and is known as the engine that is responsible to drive the FTTH system. The three utmost functions of optical line terminal are:

1. Traffic scheduling
2. Buffer control
3. Bandwidth allocation

The redundant DC power is used to operate the OLT, at least has a Line Card used for incoming internet, a System Card for onboard configuration and single to many GPON cards. Every single GPON card has various GPON ports.

THE BLOCK DIAGRAM OF OLT:

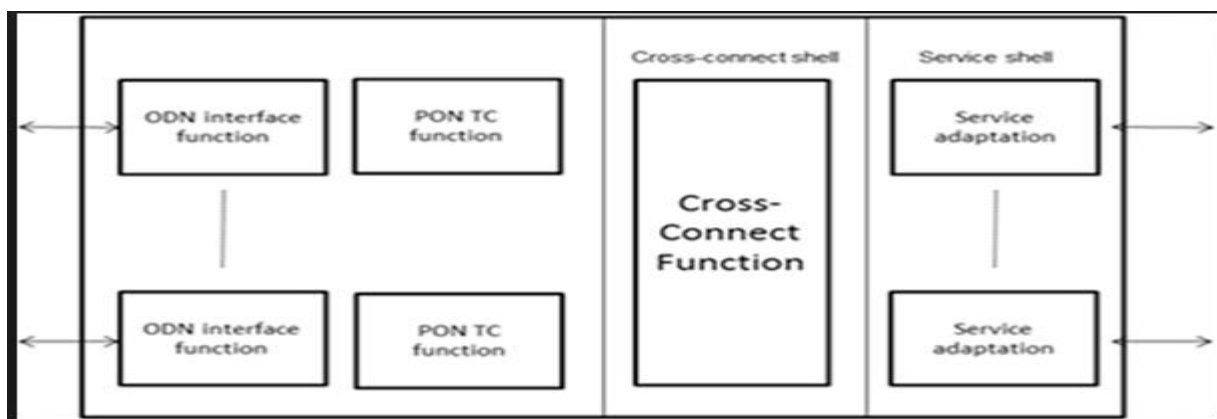

Figure 55: BLOCK DIAGRAM OLT

Reference: https://www.tutorialspoint.com/ftth/ftth_gpon.htm

PON CORE-SHELL

The PON Core-shell has two important parts:

1. ODN interface function
2. PON TC function

PON TC function includes the following:

- a) OAM
- b) Media access control
- c) Framing
- d) DBA
- e) The depiction of the protocol data unit (PDU) for the management of ONU and the cross-connect function.

Cross-connect shell

It is the medium path between the PON core shell and the service shell.

Service shell

In the PON section, the shell that is for the translation between service interfaces and the TC frame interface is the service shell.

3.8.2 ONT/ONU (OPTICAL NETWORK TERMINAL)/ (OPTICAL NETWORK UNIT)

The signal of the ONU is converted to an electrical signal from the optical signal after that the electrical signals are then sent to individual customers. There are always several ports of ETHERNET used for connection to IP services like CPUs, phones, wireless. ONU is used for the Link Aggregation also generally called for the link protection. ONU uses one or maximum two PON interfaces to serve the purpose of protection. So, it can be understood that by the term link protection itself means that if one fiber out of the two connected goes down, the other can be used to access the ONU. To connect PON with the customers, multiplexers and demultiplexers are used. ONU could be connected by various methods and cable types, like twisted-pair copper wire, coaxial cable, optical fiber or Wi-Fi.

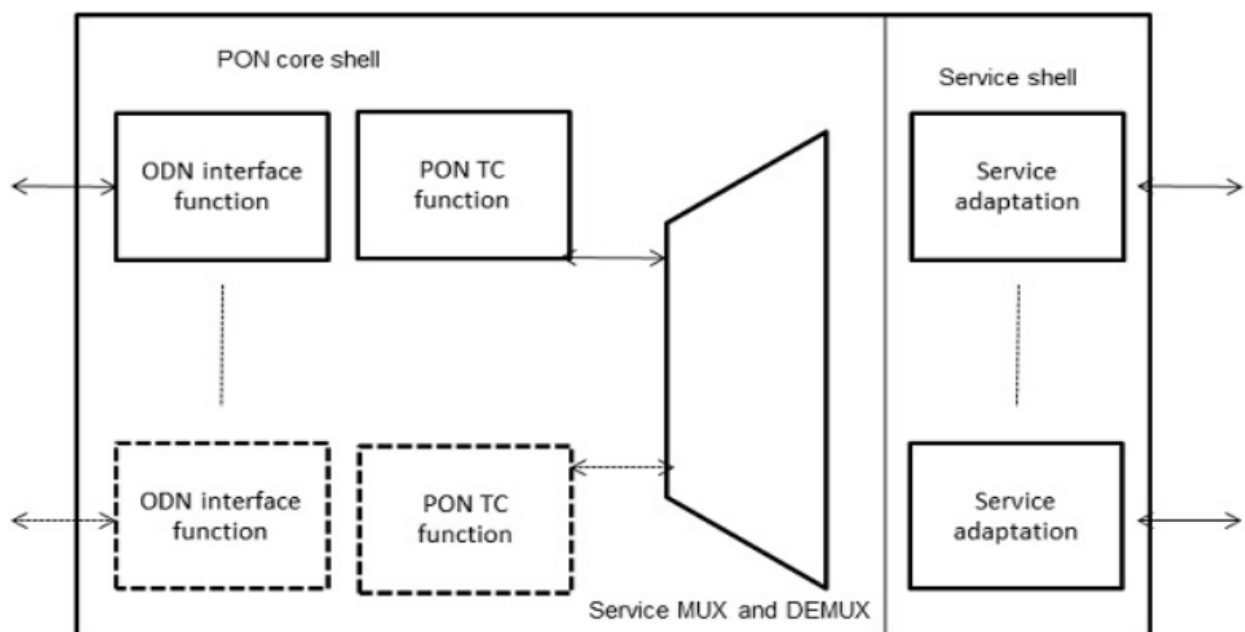

OLT BLOCK DIAGRAM

Reference: https://www.tutorialspoint.com/ftth/ftth_gpon.htm

ONT is the same as ONU. ONT is assigned by ITU-T, whereas ONU is the name given by IEEE. ONT is generally on customer premises and can be connected to the OLT with the optical fiber and there are no active elements present in the link. In GPON, the transceiver in the ONT is the physical connection between the customer premises and the central office OLT.

ONU could be a better option where the CAT-5 copper cable is already laid like the user in the campus as hospital or school or corporate offices.

ONT/ONU Interfaces

There are several user-network interface ports in the ONT for the service network interface that is connected to the OLT. Towards the UNI (user network interface) there are four FE/GE ports that are:

1. For the Residential ONT the UNI ports are: –
 - a) 10/100Base-T High-Speed Internet (HSI) and video over IP
 - b) RF coaxial for RF video overlay systems
 - c) FXS telephone interfaces are analog for VoIP PSTN voice.
2. For business ONT the UNI ports are:
 - a) 10/100/100Base-T routers and L2 / L3 switches interfaces
 - b) DS1/E1 PBX

The GPON fiber is terminated by the ONU and it has many user network interface to many subscribers. UNI interfaces include one of the following: ADSL2+, VDSL2, Power Line, and HPNA. The distance to the user 10/100 Base-T is up till 100m that is 330 ft.

It depends upon the interface ports and could be possible that UN UNI could not directly connect to a subscriber customer premises equipment.

For cases like this, the UN UNI is connected to a network termination (NT) that is placed at the final location of the subscriber. The CPE equipment such as a PC, Wireless Router etc. is terminated by the NT of the user.

Basically, the ONT is a combination of functions of ONU and an NT in a single device which makes the ONT a cost-effective solution to give the GPON services to local and single-family.

3.8.3 SPLITTER

The splitter is a broadband branching device that is bidirectional that has a single input port but multiple output ports. The downstream signal when the input to the splitter from the OLT is divided into the various output ports with this a single optical fiber can be used by multiple users and also share the available bandwidth. In the case when the upstream signal in input to the splitter, optical signals from several ONTs are combined into the single fiber.

Splitters are passive devices because there is no requirement of an external energy source other than the incident light beam. Generally, three or more levels of fibers correspond to the splitters of two or more levels that allows sharing of each fiber by many users.

The passive optical splitter has properties like broad operating wavelength range, low insertion loss and uniformity, minimal dimensions, high reliability, and supporting network survivability and protection policy.

For the manufacturing of splitters there are basically two techniques used:

1. Fused Biconical Taper (FBT)

To make 1x2 Fused Biconical Taper splitter two fibers are precisely fused together. If we cascade multiple 1x2 splitters we achieve higher split ratio.

2. Planar Lightwave Circuit (PLC).

PLC splitter has a microscopic optical circuit that is made by silicon.



Figure 56: SPLITTER

Reference: <https://www.google.co.in>

The splitting loss is the major parameter considered for the FTTH network designer and is the span between the central office and the user or is the maximum optical budget allowed in the system. The optical budget is by the attenuation from splices, connectors, the optical fiber, and splitters. The most demanding is an optical splitter in terms of losses.

3.8.4 ODN (OPTICAL DISTRIBUTION NETWORK)

The optical distribution network (ODN) is the one that is used in the transmission between OLT and ONU/ONT. The maximum distance that is supported for transmitting across the ODN is 20 km. The ODN specifically has five components which are feeder fiber, optical distribution point, distribution fiber, optical access point, and drop fiber.

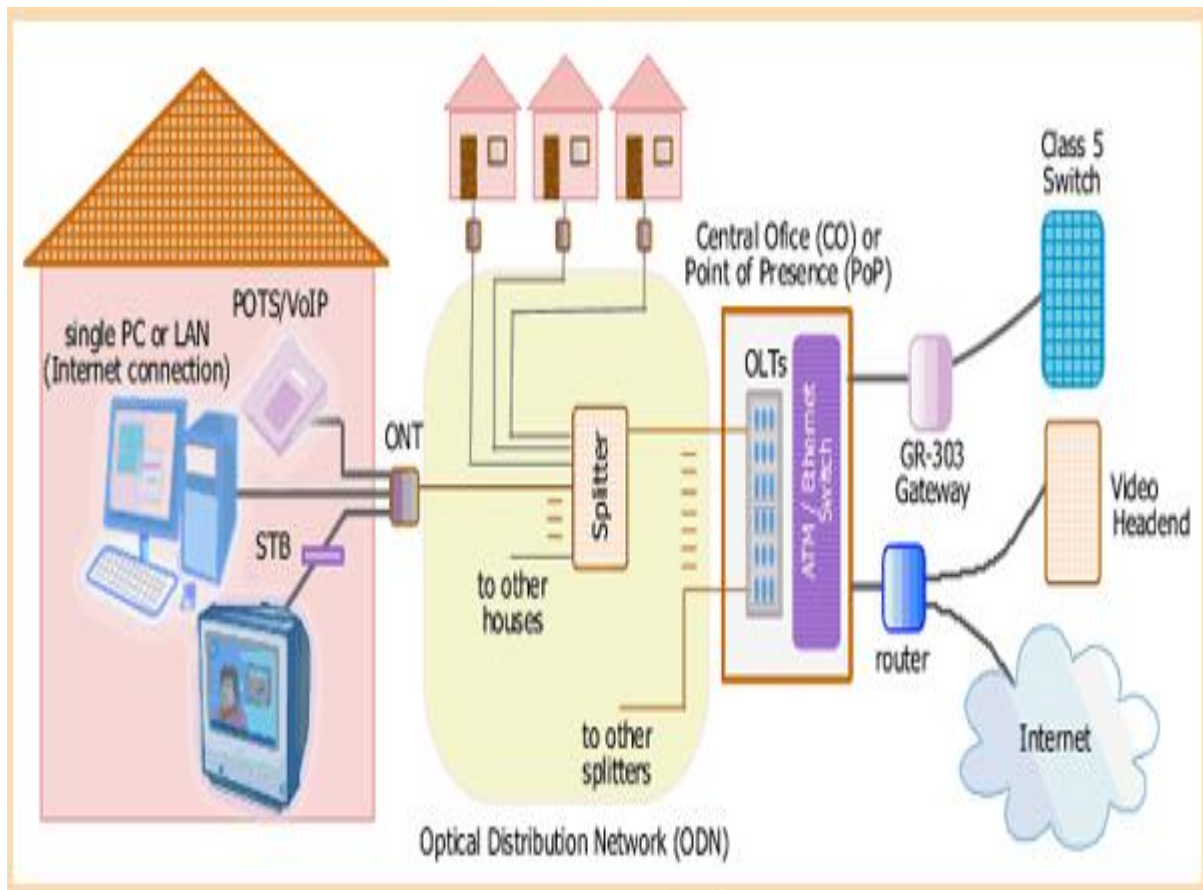

Figure 57: ODN

Reference: <https://community.fs.com/blog/abc-of-pon-understanding-olt-onu-ont-and-odn.html>

3.9 GPON FTTH ARCHITECTURE

The FTTH access network has five parts:

1. Core network area is the area that consists of the Internet service provider (ISP), Public switched telephone network (PSTN).
2. Central office's function is to
 - Provide the power
 - Host the OLT and ODF (optical distribution frames)
3. Feeder area is the area from ODF that resides in the central office to the distribution points that are street cabinets, called FDT over there, there are level-1 splitters. The ring topology is generally used for the fiber cable that starts from GPON port and ends in another GPON port for the type B protection.

4. In the distribution area, the distribution cable is used to connect the level-1 splitter to level-2. At the entrance of the neighborhood, the level-2 splitter is placed in a pole mounted box that is called Fiber Access Terminal.
5. The level-2 splitter inside the FAT is used to connect to the subscriber premises through drop cables, in the user area. A patch cord is used to connect the ONT to the ATB.

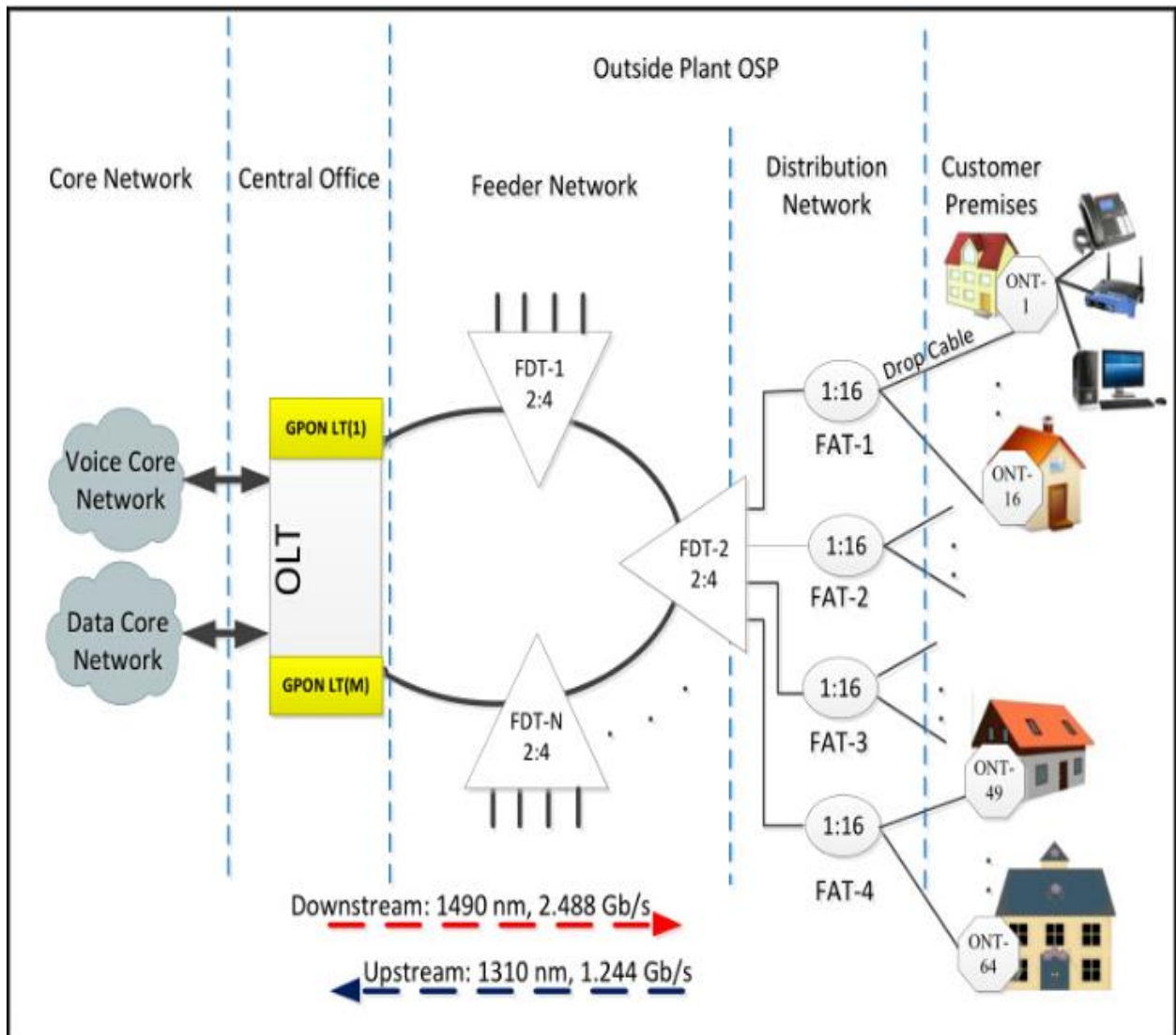

Figure 58: GPON FTTH ARCHITECTURE

Reference: <https://www.google.co.in>

3.10 GPON NETWORK PROTECTION MODES

There are four types of network protection modes in GPON:

- I. Fiber BACKUP

- II. OLT INTERFACE BACKUP
- III. ALL BACKUP
- IV. MIXED BACKUP

3.11 Power Budget

The two parameters that define the reach of the access network are transmitter power and receiver's sensitivity. For the calculation of the worst-case power budget, the minimum receiver sensitivity is subtracted from the minimum transmitter power. The power budget that is available is around 22 dB and 23 db.

Therefore, the maximum reach of the network is:

$$P = FCA \cdot L + SL + \text{Penalties}$$

P is the power budget

FCA is Fiber Cable Attenuation in dB/m

L is a distance and SL is a splitter loss.

CHAPTER 4

CORD

4.1 INTRODUCTION TO CORD

CORD implies Central Office Re-architected as Datacentre. As the name demonstrates Central office is re-architected as Datacentre to present cloud style economies of scale and readiness. Telecom and Cable Providers are regularly developing and continually searching for innovation and thoughts to make increasingly productive designs. The expansion of administrations and its quality has prompted consistent enhancements. These specialist organizations are continually looking for models to accomplish fulfilment for the need the business has created.

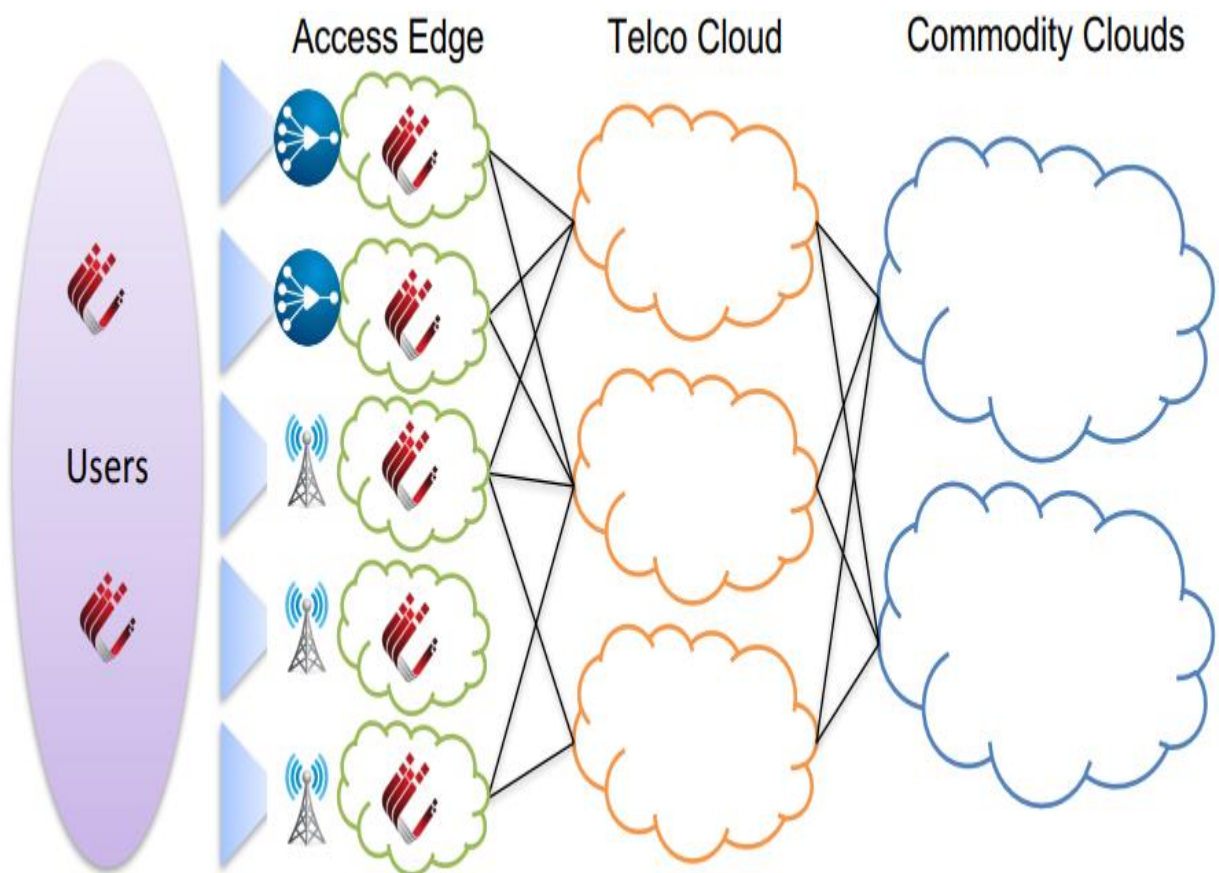

Figure 59: MULTI-TIER CLOUD

Reference: <https://www.google.co.in>

CORD is building an edge service delivery platform, this a multi-tier cloud that everyone will be using. This is the piece of cloud that is close to the edge users and sometimes it is actually on the end users' premises.

So, this is called the edge service delivery platform. It is like a particular edge service delivery platform and by particular it means that very high standards are set to put it together.

CORD is utilized by service providers as a broadly useful delivery platform. It supports distinctive sorts of structures for residential, business areas. The design can be tweaked to get any mixtures of these architectures utilizing CORD.

CORD installation has a set of services characterized by a parameter called service graph. Service Graph makes it conceivable to redo the arrangements and access the application and advancements as required. It could likewise be characterized as innovation viewpoint for CORD.

Furthermore, from the community's point of view work is sorted out around useful domains like residential, mobile etc. at some point to different applications model gaming, VR and so on.

The objective of CORD isn't just to take place of the legacy network components with increasingly agile parts but also to empower the CO to rapidly support more important administrations.

Hence, the cord has an establishment in CO hardware aggregation and disaggregation architecting equipment packs to help software definition and to empower the virtually detailing of foundation needs dependent on new service prerequisite.

In late 2014 and start of 2015, the concept of CORD came. January 2015 was actually the time when the name CORD comes into play. In September 2017 the fourth version of CORD was released called 4.0 but it is considered as 1.0 since it like a start over again it's considered kind of complete now. The platform is stabilized, and it is moved into the world where distribution is a little bit of release.

If we look at the architecture requirements:

1. CORD is built using commodity servers and white box switches by leveraging merchant silicon and achieving performance and reliability in software.
2. It supports a wide range of services; the services range from legacy VNFs all the way to disaggregated Greenfield services. These services do not just run on x86 but sometimes they run in the forwarding plane of white box switches. So, the server-based services often called VNFs, NFV and switch-based services called the SDN services. The important point is SDN is not here just for planning together VNFs the SDN services are the services that we can offer to the end users.
3. To build an extensible platform and not to build the point solutions. It depends upon the scale hardware up/down to meet the requirements. It is to get the right task performance tradeoffs to know how much customers we have and so not to throw excess servers. To select the access devices and services to meet the functional requirements, leverage declarative models to configure and control.

4. To support the multi-tenancy. The platform being multitenant and different business units and trusted parties could bring services, for example, Amazon cloud is the third party but also to get each of the service to be deployed in the multitenant cloud, themselves being the multitenant services. Services in the cloud are multitenant but the problem is that when we couple that with this disaggregation it is very challenging because now it is multi-tenancy cross-product with disaggregation and that is something that has never been done before.
5. The last is operationally robust which could be summarized as adopt to best practices in building scalable cloud services and zero-touch provisioning.

The below are the four really challenging things to do but the combination will make it fantastic. These are:

1. Merchant silicon
2. Disaggregation
3. Extensible Platform
4. Multitenant

There is another way of thinking about this which is cloud technology to the access network best practices of the cloud brings to the central offices but there is an equally important thing that is to bring the access technology to the cloud which means everything of the cloud has to be there. Access is again something different and to bring it to the cloud will be challenging again.

If we say CORD is a small data center, we are partially right. For the WAN connection, the data comes in a bunch of computations happen and data goes out.

There are a switching fabric and a bunch of computing storage. There are very large pipes going east and west from one server to another and the pipe going to the northbound relatively is much smaller.

We will think the CORD as a generic I/O we are not connecting to the outside world northbound, but we will connect to the outside world east and west. It is a cloud where data comes in, it may or may not hit a server and goes out that is the common case in which all bunch of capabilities and functionality and services might affect the switching fabric. The switching fabric is not just to connect the VNFs together but to actually give value and that is one of the things that is different in this.

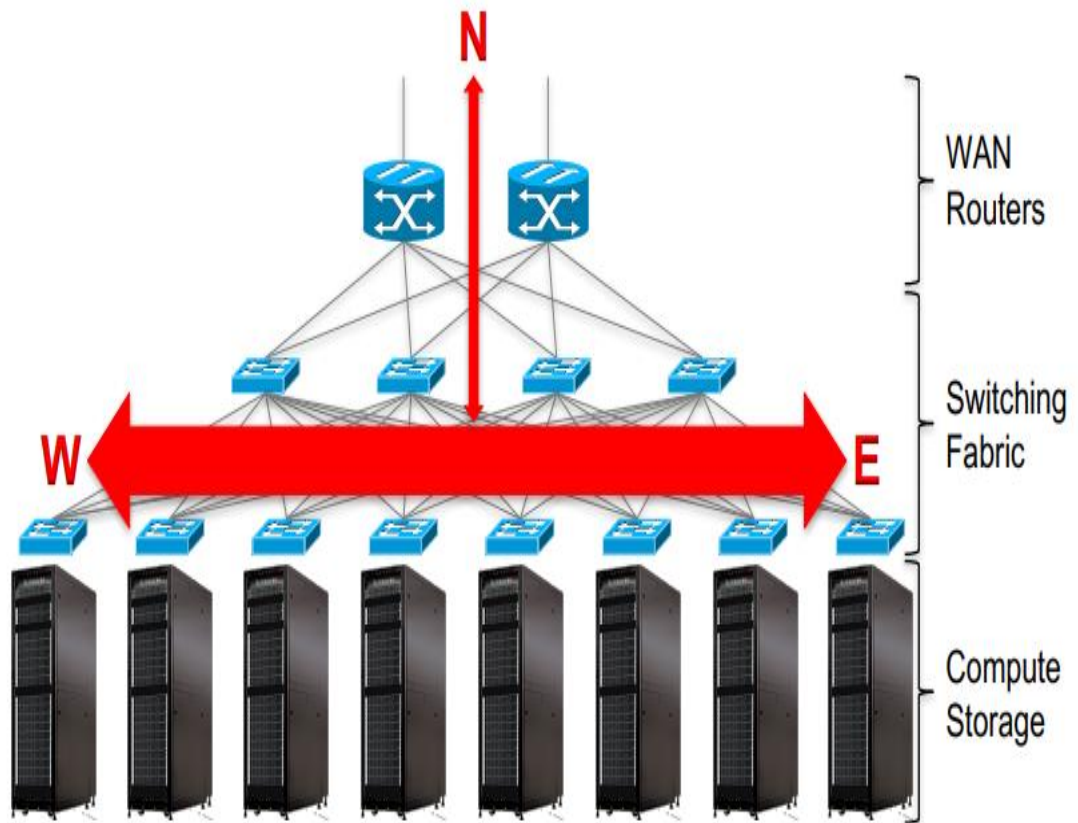

Figure 60: DATA CENTER

Reference: https://www.opennetworking.org/wpcontent/uploads/2019/01/Day1_Session8_CORD-Build.pdf

The major types of CORD are:

MCORD: Mobile CORD

ECORD: Enterprise CORD

ACORD: Analytics CORD

RCORD: Residential CORD

If we map it to all the components that are going in the CORD. We have the RCORD and MCORD which are focused on the access side.

ECORD is not focusing much on the access side but the innovation relatively is how to connect several central offices together to the backbone network that might itself be programmable and dynamically can take the virtual network. A virtual network is one of the key innovations there. There are lots of efforts that go in the switching fabric which is the foundational piece it is part of the CORD platform.

4.2 CORD ARCHITECTURE

1. From the bottom if I would explain it we have the hardware specifically we have OCP hardware commodity servers, white box switches, merchant silicon access piece of boxes that is all is illustrated at the bottom layer of the above diagram. In addition to the leaf spine switching fabric one of the racks is the rack of the ONU access boxes. We treat them like switches, and we try to control them the same way. Those access devices are part of switching fabric and there are servers as well.
2. In the second level from the bottom we have all the services and VNFs and so we will see the open stack and some compute infrastructure services. In essence, we are a disaggregating infrastructure of service as a unit. Let's think of computing as a service that's a better match and it could be virtual machines and containers. So, we can support a broad range of services bundle VNFs and virtual machines, micro services, and containers, services implemented on ONOS it is all captured in here. The design is virtualization technology agnostic, virtual machines.

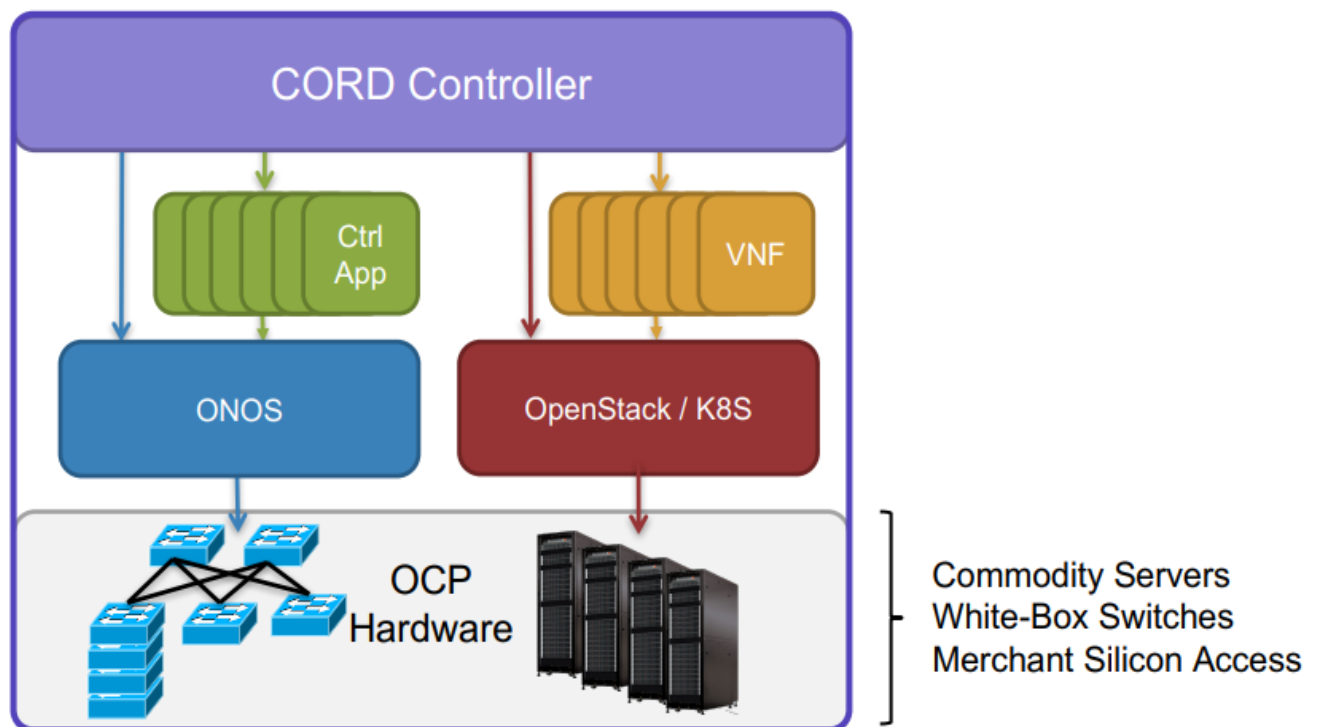

Figure 61: CORD ARCHITECTURE

Reference: https://www.opennetworking.org/wpcontent/uploads/2019/01/Day1_Session8_CORD-Build.pdf

I will talk quickly about MCORD, ECORD, and ACORD, however, with respect to this task, I will go in detail for RCORD in next chapter.

4.3 MCORD

The present Mobile Network Service Provider's infrastructure is designed with proprietary vertically incorporated Network Elements (NEs), coming about into inefficient use of system assets. It is additionally exceptionally hard to make changes to the present infrastructure for various remote endorser needs or areas. Also, these heritage models don't bolster the required speed of rising services necessities.

The wireless business has built up the Mobile Central Office Re-architected as a Datacentre (or M-CORD). This could be referenced design for re-architecting the present versatile telecom foundation into a Data Centre (DC) to accomplish cloud-style economies.

M-CORD targets mobile networks and is affected by developing 5G. It oversees how NE functions can be accumulated or disaggregated with instantiation on infrastructure to lower CAPEX costs. The future outline of M-CORD isn't just to supplant inheritance NEs with increasingly agile parts, yet to likewise empower the mobile network to rapidly bolster progressively appealing and important mobile services.

M-CORD changes the legacy of mobile network design by decoupling control and data planes. The control plane is logically brought together, and mobile networks and MNO services are disaggregated and virtualized. What's more, virtualized functions and services are bundled as versatile entities in the general mobile system. M-CORD is a reference design arrangement and based on the mainstays of Software Defined Networking (SDN), Network Function Virtualization (NFV) and cloud advance. It utilizes open source software, disaggregation of Network Elements (NEs), and virtualization of Radio Access Network (RAN) segments and other essential elements of mobile systems. M-CORD is a perfect quick development stage towards 5G systems, permitting MNOs to try different things with 5G innovations without looking out for confirmation of benchmarks.

Developing 5G systems must help to expand data rates and a typical framework where new wireless services depend on immensely unique system QoS necessities. To address such requirements, a 5G design needs the capacity to progressively make programmable virtual systems, and separate traffic treatment using arrangements dependent on the idea of Network Slicing. Network Slicing uses M-CORD's key highlights of disaggregated virtualized RAN and EPC parts, alongside open source usage for RAN and Evolved Packet Core (EPC) that permits customization and modification. M-CORD depends on the developing RAN engineering with incorporated baseband preparing Digital Unit (DU) hubs giving an on-request allotment of calculation/handling resources. The Front haul organize interfaces the CO Virtual Baseband Unit (vBBU) pool, which is likewise alluded to as a Digital Unit (DU) pool, with geologically scattered Remote Radio Units (RRUs). Data is traded between the RRU and the DU Pool (or vBBU pool) over the Front haul access network. The objective of decoupling the baseband preparing from the RRUs is to improve redundancy and augment the operational quality of the DU pool.

The Front haul network protocol is a convention standard between the centralized vBBU pool and Remote Radio Units (RRUs) is the Common Public Radio Interface (CPRI) specification.

To deal with the associated radios, the vBBU utilizes the CPRI standard for the vBBU-RRU interface to exchange synchronization, radio flags, and control and the management signalling. The best service for CPRI is dark fibre because the encapsulation of CPRI into another protocol presents excessive latency and jitter to agree to the detail.

For a topographical zone with restricted access fibre or rental wavelengths, a ring arrangement is a choice and Passive Optical Network (PON) facility. Centralization aggregates distinctive vBBUs, few hundred Remote Radio Units (RRUs) and require numerous filaments for direct fibre associations with DUs. It is additionally critical that a front haul arrangement give 1:1 or 1+1 backups if there is a fibre failure. The rising Mobile Network Operator (MNO) Software Defined Network (SDN) display is to turn up Software Defined Radio (SDR) vBBU-DU Virtual Machine (VM) computational assets dependent on the fibre interface on a given physical port.

These vBBU-DU hubs are in a room, floor or building to shape a "vBBU-DU Hotel", with a rapid low-latency interconnection between them. Along these lines, M-CORD could encourage usage of collective wireless radio systems to diminish obstruction and enhance system execution. At the point when these arrangements are consistently coordinated with AFS items, the consolidated arrangement make costly radio and preparing equipment and the more viable shared, decreasing capital and operational consumptions. For instance, while expanding the extent of vBBU-DU Cloud, it ends up hard to change information from a discretionary RRU to any vBBU-DU. At the point when the measure of a RAN achieves a specific dimension, the resource sharing addition may turn out to be level or peripheral. In this manner, it's not economical to plan a fast completely non-blocking network vBBU-DU Cloud. To adjust adaptability and flexibility, vBBU-DU sub-clouds can be utilized with a various levelled structure for the vBBU-DU cloud at the CO.

4.4 ECORD

Enterprise CORD (E-CORD), expands on the CORD foundation to help support enterprise clients. E-CORD is intended for specialist organizations conveying SDWAN and MEF Carrier Ethernet services. Beyond basic services available, E-CORD additionally makes it conceivable to incorporate on-demand network capacities and administration piece and to convey problematic cloud-based undertaking administrations. Thus, enterprise clients can use E-CORD to make multisite virtual systems quickly between any number of endpoints or organization branches. Clients can likewise run network functions, for example, firewalls, WAN quickening agents, traffic scientific instruments, and virtual switches as on-request benefits.

The E-CORD is a collaborative effort among driving specialist co-ops and noticeable systems administration sellers. The E-CORD evidence of idea comprises of a packet optical metro network with three Central office workplaces as CORD sites. The system's client entryways and GUIs arrange enterprise administrations, cooperate with operational parameters, and perform virtual provisioning. Fundamentally, the verification of idea shows a notable disaggregated ROADM—it replaces a shut, body-based, restrictive, and vertically incorporated ROADM with a white box display utilizing open interfaces and protocols.

4.5 ACORD

Its reference architecture depends on a 3 level model that is programmable virtual tests, XOS observing as a service and analytics engine. Analytic engine screen and on the basis of analysed data derive the control choices. This is the means by which it eventually makes the Central Office arrange increasingly self-governing utilizing programmable through closed-loop control.

ACORD progressively associates information gathered with virtual tests and arranges among information authorities to keep up the wellbeing and accessibility of the overall CORD condition. It gives control and decouples investigation application from fundamental tests thus empowering genuine multi-merchant situations.

CHAPTER 5

RCORD

5.1 INTRODUCTION

RCORD is Residential central office re-architected as the datacenter.

This brings us down to the primary piece of this project named R-CORD. It implies Residential CORD. As the name demonstrates, is an open-source platform on CORD to make ultra-broadband residential services.

5.2 PURPOSE

The purpose is to bring the economies of the data center but also to bring the agility that our cloud providers have, to the central offices. There are different providers and the Telco's providers have the advantage that they are very close to the end users. Anything that we see in the future going forward all the new applications that we see AR, VR, IOT all these things will benefit greatly from having very low latencies and computing as close as possible to the end users. The providers that have the location near to the end users are of great benefit in this case. In these central offices, we want to bring the economies of the data center to use open source software white box hardware and also the agility that cloud providers enjoy in their massive datacenter somewhere very far away from where electricity and water are cheap. We want to bring the same economy and same agility to bring to central offices. So, this is the purpose of the CORD in a nutshell which justifies its name that is Central office re-architected as a data center.

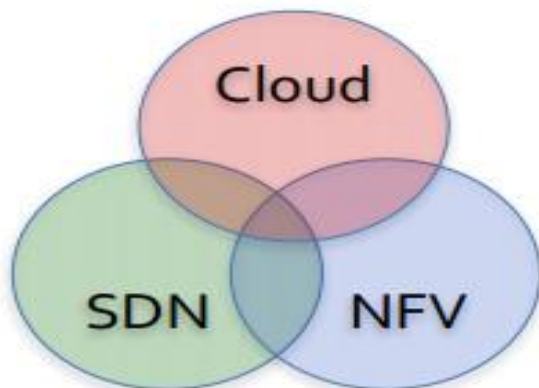

Reference: <https://cordbuild2017.sched.com/event/CFGh/introduction-to-r-cord-and-voltha>

CORD has targeted all the possible customers so as the providers focus is on all the aspects whether it is Residential, mobile or enterprise customers.

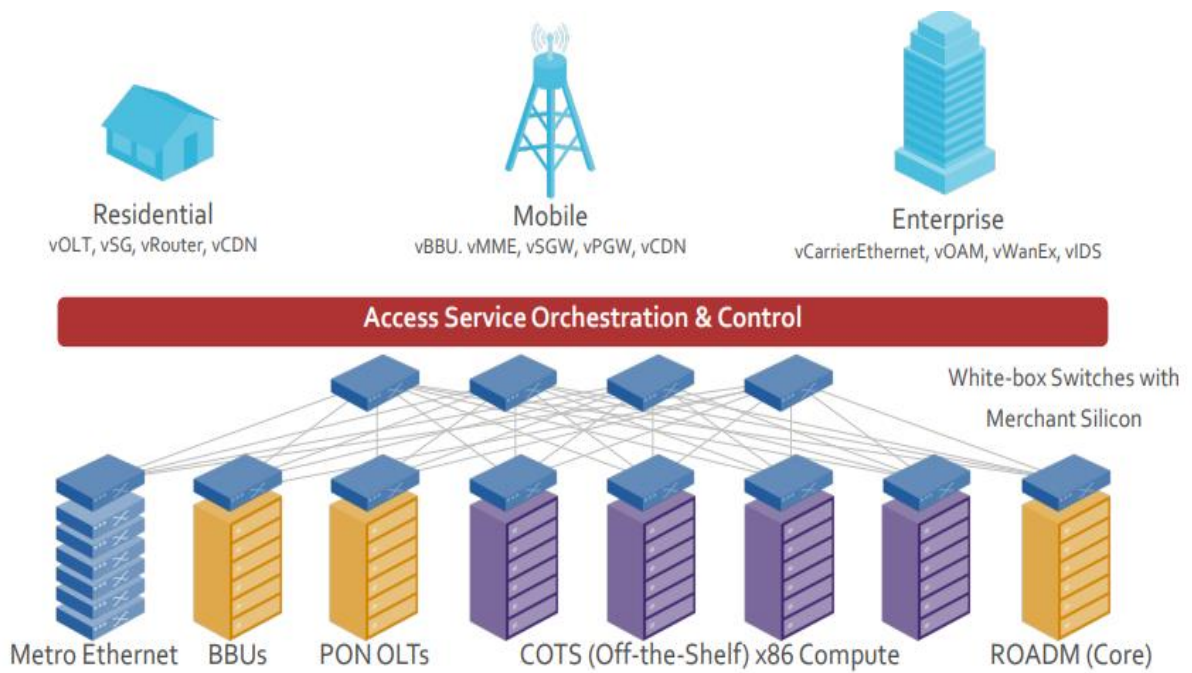

Figure 62: COMMON PLATFORM FOR ALL

Reference: <https://cordbuild2017.sched.com/event/CFGh/introduction-to-r-cord-and-volta>

We want to bring all the customers and the services provided to the customers on to a common infrastructure built on bare metal hardware and open source software. I am not talking about now different boxes for all the enterprise, mobile or residential customers. The purpose is to bring them all these subscribers to the same platform and provide different services on this common platform.

5.3 TRADITIONAL RESIDENTIAL ACCESS

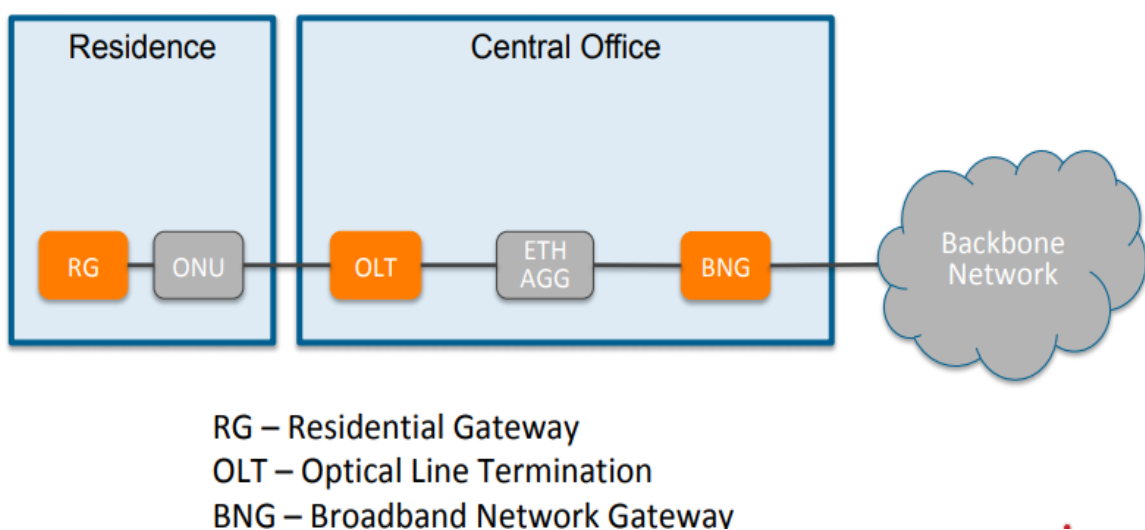

Figure 63: TRADITIONAL RESIDENTIAL ACCESS

Reference:<https://www.opennetworking.org/wp-content/uploads/2018/12/SEBA-Overview.pdf>

The diagram helps to look at what traditional residential access looks like so we can understand how things have evolved when we decide to get this equipment and then run it by using software running on bare metal switching hardware whether it's commercial off-the-shelf servers or white box switching hardware. So, in the traditional residential access typically if I am looking at the PON that is the end head box known as Optical line terminal that then goes through fiber distribution networks and reaches the homes where we have optical network units or ONU that talks to the OLT and behind that residential gateway and then another kind of services voice, video data and so on. The number of these OLTs then get aggregated into the Ethernet aggregation switch and further than that traffic gets terminated at the BNG or the Broadband network gateway.

5.4 OVERVIEW OF DISAGGREGATED RESIDENTIAL ACCESS

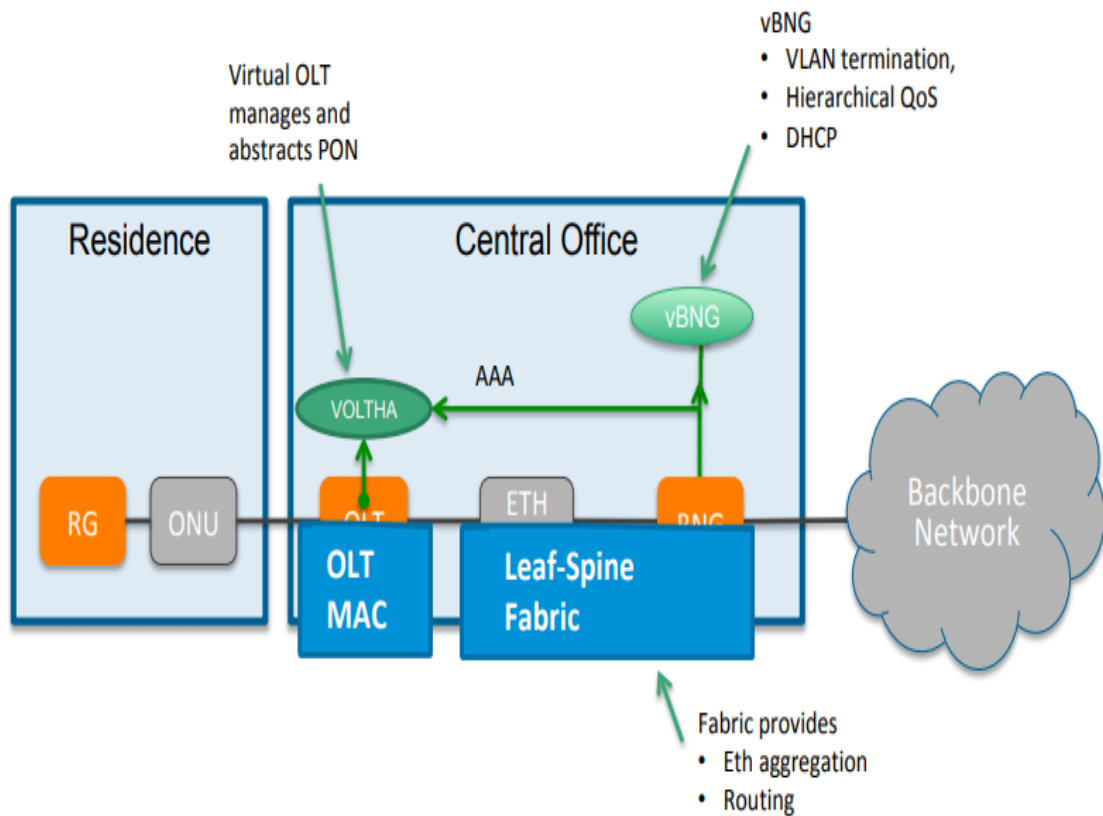

Figure 64: DISAGGREGATION

Reference:<https://www.opennetworking.org/wp-content/uploads/2018/12/SEBA-Overview.pdf>

What is done in the CORD is depicted above an overview of it that let's take the OLT but take the only part of the OLT that is meant for doing the optical work with the set of ONUs, take the MAC functionality out of the OLT. Leave that hardware but the software that manages this box that controls the functionality of that let's pull that out into a virtual OLT. Then let's take a further look at these other boxes but maybe the function of moving bits around looking at IP

address, Ethernet addresses of the forwarding traffic based on those that can be replaced with fabric and the functionality that in software can be moved into say containers that run on VMs that runs on servers commercial off the shelf equipment , so leave the hardware to do the things that it's supposed to do whether it's on the optical side or Ethernet side but the control of that hardware let's pull that out of this specialized equipment and move it into servers so what we have done beyond that is we have said that this hardware does not have to be specialized these can be built using white boxes. The use of white boxes is pulling control software out and moving it into white boxes and servers so when we do this and then we do this not just for residential subscribers but also for mobile and business customers that's when we get the CORD architecture and it also gives us the ability to introduce other services. At this edge, CO is really close to the end user that's the edge that gives us the ability to introduce other third party services.

5.5 Detailed Residential CORD and its components

Residential CORD (R-CORD) incorporates the services that support wireline access technologies like GPON, G.Fast, 10GPON, and DOCSIS. In the first release the following devices were included which are as follows:

1. vOLT (Virtual optical line terminal): A disaggregated and virtualized OLT device for GPON.
2. vSG (Virtual Subscriber Gateway): It is implemented by a container that is bound to each subscriber.
3. vRouter (Virtual Router): A core networking service that is an ONOS control application.

The details of each of these will be discussed in detail in the upcoming sections:

5.5.1vOLT

In the vOLT I will consider the following sections which are:

- a. Introduction to vOLT
- b. The first step to Authenticate the Packet Trace
- c. The architecture of VLAN
- d. The Components of the software
 - a. vOLT Agent
 - b. ONOS applications

5.5.1.1 INTRODUCTION TO vOLT

The link of the ODN in the Central office (CO) is terminated by the OLT devices and with this, all the subscribers are aggregated by a physical termination point. Here I will introduce the concept of the virtualized OLT which has been replaced by the standard OLT devices and this vOLT is a combination of both the commodity hardware and the open source software these two terms will be in use really commonly in my upcoming report. The main focus in the start was on the GPON (Gigabit passive optical network) but can be applied to the other technologies too. One example of other technologies is G.Fast that is not developed fully yet. How about we see R-CORD and the disaggregation of an OLT (Optical Line Terminal), which is a huge case framework introduced in CO's to deploy G-PON. G-PON (Gigabit Passive Optical Network)

is deployed for residential broadband and triple play services. It provides service of 2.5 Gbps Downstream, 1.5 Gbps Upstream shared among 32 or 64 homes. This disaggregated OLT is a key part of R-CORD.

To rearrange, an OLT is a chassis that has the power supplies, fans, and a backplane and the latter is the interconnect innovation to send bits and bytes from one card to another. The OLT incorporates two management blades (for 1+1 repetition), at least two "uplink" blades (Metro I/O) and whatever remains is filled with "line cards" (Access I/O). In GPON the line cards have many GPON Access ports each supporting 32 or 64 homes. In this manner, an OLT with 1:32 parts can bolster 10,000 homes relying upon port density.

Disaggregation maps the physical OLT to the CORD stage. The backplane is supplanted by the leaf-spine switch fabric. This fabric "interconnects" the disaggregated blades. The management move to ONOS and XOS in the CORD demonstrate. The new Metro I/O and Access I/O edges turn into a fundamental piece of the improved CORD engineering as they turn into the I/O racks of the CORD stage.

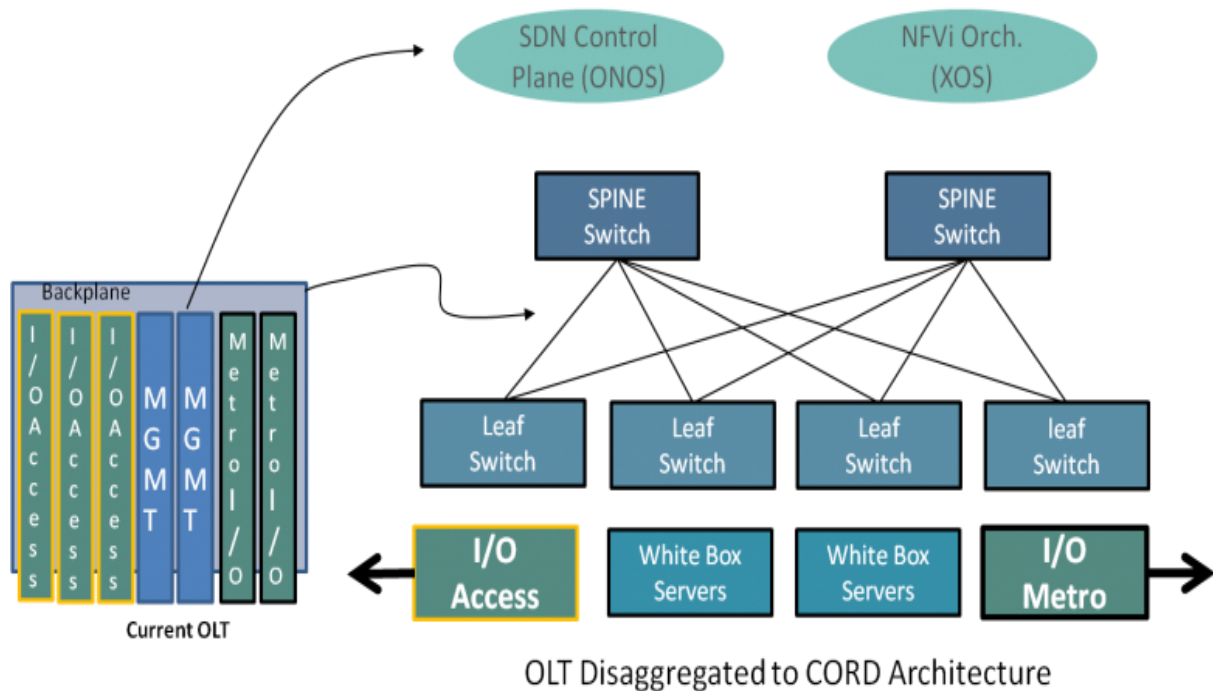

Figure 3

Source: Greywale Insights

Figure 65: DISAGGREGATED OLT

Reference: Greywale Insights

For this, the first step is to create an I/O blade with the PON OLT MAC. AT&T is working with the Open Compute Project for the development of an open specification for GPON 1RU "pizza box". This blade includes the essential GPON Media Access Control (MAC) chip which is controlled by a remote control program, which is, in turn, controlled from high-level applications through OpenFlow. This replaces an existing closed and proprietary OLT chassis that integrates this GPON MAC chip with GPON protocol management, 802.1ad-compliant

VLAN bridging, and Ethernet MAC functions. These other functions from the legacy device are being unbundled and these are then implemented in software. The box shown below is frequently referred to as a white-box OLT, but it is important to note that **each port on the box is a separate PON OLT** with 32 or 64 subscribers.



Figure 66: GPON OLT IO Blade.

Reference: <https://wiki.opencord.org>

This Access I/O blade is likewise alluded to as the GPON OLT MAC and can bolster 1,536 homes with a 1:32 split (48 ports times 32 homes/port). Also, the 48 ports of access I/O can bolster at least 6-40 Gbps Ethernet ports for associations with the leaf switches.

This is just the start and by itself has a strong value proposition for CORD within the service providers. For instance, if you have 1,540 homes "you should simply "install a 1 U (Rack Unit) rack. Never again do you need to introduce another substantial body conventional OLT that bolsters 10,000 homes.

There are two portions of software that functions together to put into effect the vOLT functionality. This two software are:

1. The first is a vOLT agent that runs in a container or VM and allows a connection among ONOS and the hardware. The agent exposes an OpenFlow interface northbound which enables it to be managed with the aid of ONOS. The OpenFlow messages are then mapped to the native APIs of the hardware device and OMCI messages that manage the PON ONTs. The vOLT agent additionally performs a bootstrap operation. During this technique, the agent discovers the IO blade and establishes a control connection to it. The vOLT software program then exposes an OpenFlow interface to ONOS who then uses that interface to program the vOLT agent. The agent converts those OpenFlow messages to OMCI to provision the OLT.

2. The next software program is a collection of functions that manage a number of the control plane functions of a conventional OLT, like 802.1X, IGMP Snooping, VLAN bridging, and OAM. These control features manage the other control plane functions of OLT and are carried out as packages running on top of ONOS, facilitate subscriber attachment, authentication (AAA), establishes and manage VLANs connecting client devices and the central office switching fabric on a per-subscriber basis.

5.5.1.2 The first step to Authenticate the Packet Trace

The figure below illustrates the end-to-end system, the figure includes:

- a) In the home is an OpenFlow CPE
- b) In the Central Office, there are OLT blades racks
- c) A collection of commodity servers connected by a leaf-spine switching fabric constructed from a collection of white-box switches.
- d) On one of the server the radius server will run, and vOLT “running on top of” the CORD software stack.

For this section, we consider the vOLT as a control app that is running on ONOS.

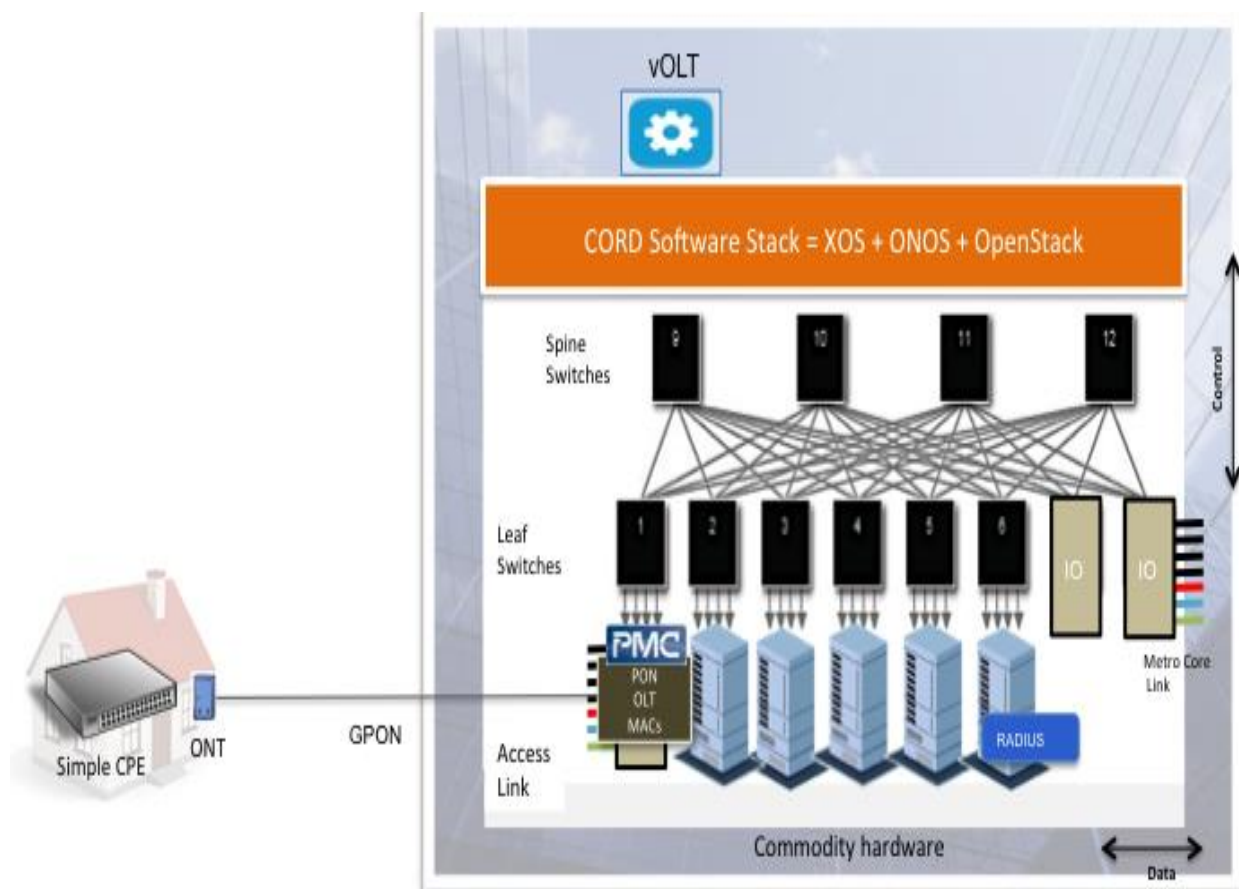

Figure 67: vOLT AS CONTROL APP

Reference: <https://wiki.opencord.org>

Initial packet exchange authenticating the subscriber.

At the time of the booting of the open OLT the vOLT application is attached to it and its GPON MAC also gets started.

At this time the system may or may not know about the ONTs that are attached to it and has their power on.

The vOLT is being reported through OpenFlow port status message as an ONT gets attached to PON. The significance of this OpenFlow port status is that:

- a) It reflects the new ports that get added to the GPON system
- b) The serial number of the ONT is also indicated by it.
- c) All the new and not expected ONT attachments are allowed to be dealt with the extending the vOLT logic with the help of it.

The port active messages of the interfaces that becomes active on the ONT can be received the moment the ONT is attached.

This commonly takes place when CPE gets attached to the ONT with the help of a physical cable or can also happen when two are internal interfaces are combined into one.

When this started then the OpenFlow rule is applied by vOLT to the interface it will help it to get 802.1X packets that are provided by CPE and all the rest of the traffic gets dropped.

Figure 69 below depicts when the CPE present in the home gets rebooted for the first time and the packet sequence is as follows:

1. The CPE that is present at the home by using a certificate that is provisioned on it builds an 802.1x packet and this packet is sent upstream where the OLT blade receives the packet.
2. This 802.1x packet is received by the OLT and is forwarded to the ONOS, the ONOS further delivers this packet to the vOLT.
3. Then the radius server comes into play there the 802.1x packet's information is used to query the RADIUS server by the vOLT application. At the radius server if the authentication is successful then the associated information of the profile is returned back.

Initial packet exchange authenticating the subscriber

Now after the successful authentication, the vOLT control application connects the subscriber to the vSG using a VLAN. The vSG is present in the Central office. Then the following steps get involved in this:

1. A subscriber call is invoked on XOS that is used to spin up a vSG container in place of subscriber doing this.
2. The VLAN is assigned to the subscriber and the OLT is informed that the traffic should be tagged to appropriate VLANs.
3. The binding between vSG container and VLAN needs to be informed to the ONOS control app that manages the switching fabric by it.
4. The packets that are assigned need to be defined with QoS markings to the appropriate queues that are for both the upstream and downstream.
5. The successful authentication token needs to be returned to the CPE.

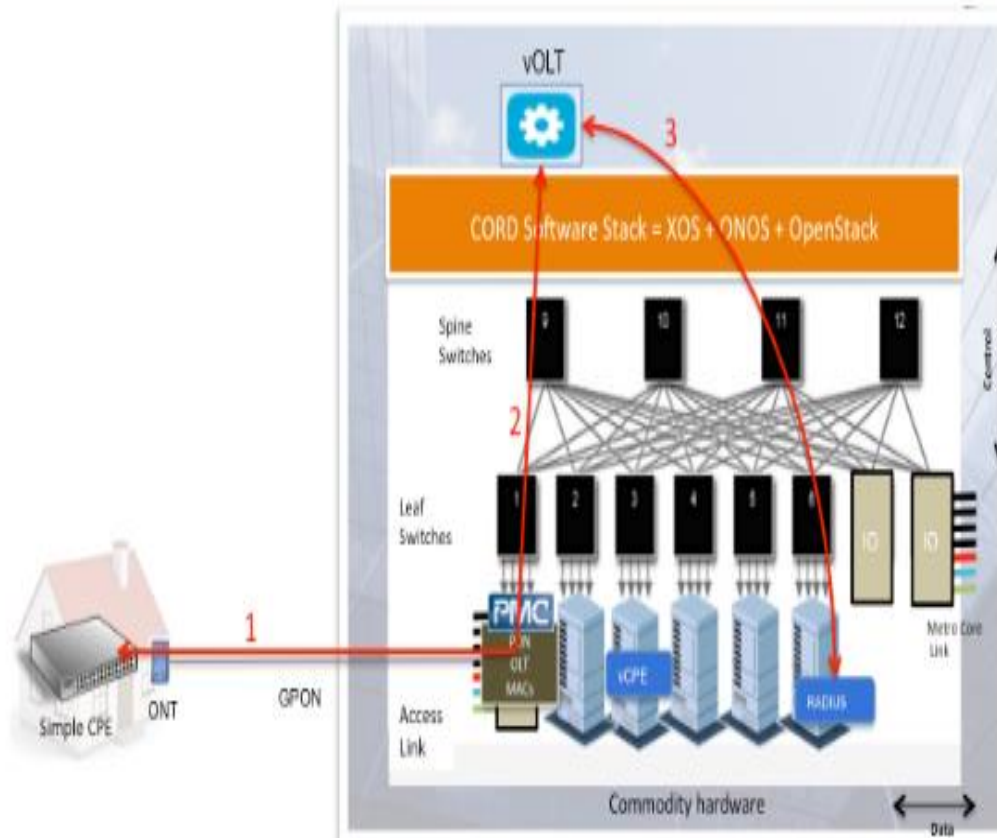

Figure 68: CPE REBOOTED FOR FIRST TIME

Reference:https://wiki.opencord.org/pages/viewpage.action?pageId=1278086&preview=/http%3A%2F%2Fh5.googleusercontent.com%2F8GiYkijdimBnv6yywuXnz4oU0VGRk2Xp2VblSSqCovkqPDg3zATWNWctnq4IyJXCpAk9RTKobndclML4PgSs6KgbhLjOkTmDo7coYVxWoR__NllcQW6CxTur4Ag-Z6wX-w_x3V

Now, the traffic that is tagged with the allocated VLAN of the user can flow from any device in the home of a subscriber to the vSG.

This traffic from the CPE flows to the OLT blade and then via switching fabric to the vSG of one of the commodity servers.

5.5.1.3 The Architecture of VLAN

The traffic of the subscriber in the central office is recognized with the help of two VLAN tags. The tagging and un-tagging of this traffic from and to the subscriber is the responsibility of ONT and OLT hardware. With the help of the “OpenFlow messages” as mentioned above is used by ONOS to instruct the OLT which VLANs has to be used.

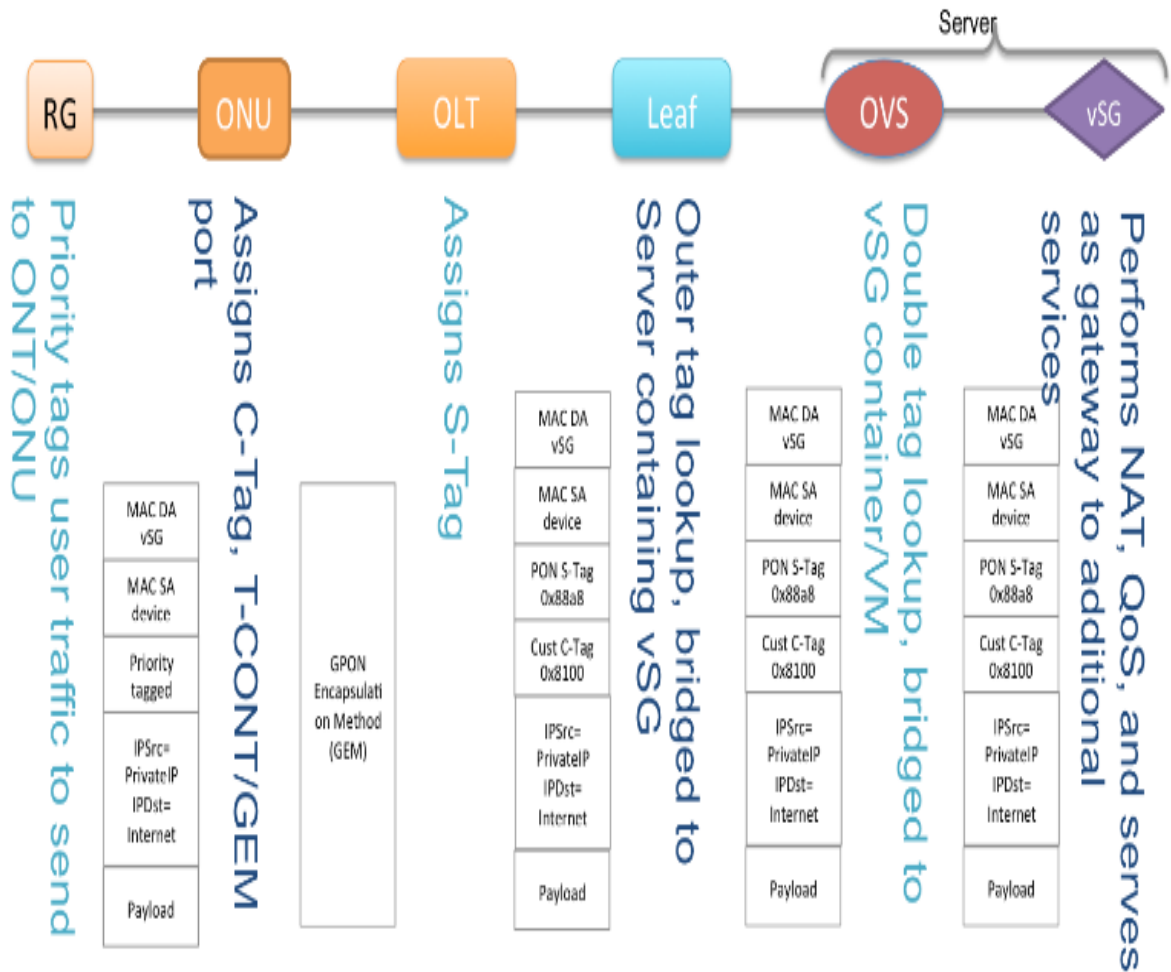

Figure 69: ARCHITECTURE OF VLAN

Reference: <https://wiki.opencord.org/pages/viewpage.action?pageId=1278086&preview=/1278086/1967477/rg-vsg.png>

The packet walkthrough from RG/CPE to the vSG

The above figure shows the place where VLAN tagging takes place in the path between the subscribers's home to the Internet. At the start that is at the user's home, there are no VLAN tags present. To serve the purpose of carrying Ethernet precedence bits the priority VLAN tag is added at the CPE or the customer home. With the help of **OMCI messages** sent to the vOLT agent, the OLT guides the ONT to add or remove the **C-Tag** to traffic that is inside PON.

The OLT itself adds **S-Tag** to the packet so that it can identify the user traffic in a fabric. This is the 1:1 VLAN mapping. The inner tag that is C-Tag in the PON recognizes the specific user. The outer tag that is S-Tag recognizes the PON. All together both the S and C Tag can recognize a user through the OLT devices. The outer VLAN tags are mapped via the fabric to a server that has vSGs for every customer in PON. There is working going on for the future release to place the vSG for a customer in the cloud anywhere. The vSG after this does the following:

1. VLAN tags are stripped.

2. It performs its functions.
3. The packet is forwarded along the service graph

After the vSG, there is no need for VLAN tags since to the vSG's WAN address the vSG NATs the traffic and that is unique.

5.5.1.4 The Components of the software

A. vOLT Agent

A function maps the capabilities of OLT and ONT through assigned APIs for the emulation of distributed Ethernet switch to OpenFlow controller. At the time when vOLT agent boots up it gets connected to the hardware. At this time, it starts an OpenFlow connection with the controller. The agent shows the entire PON system as one switch to the controller. Even if there is one port for the uplink connection every ONU appears as an individual OpenFlow port. The agent will understand limited messages from the controller and will configure the hardware according to it.

B. ONOS applications

1. vOLT application: The application is responsible to configure VLAN tags on OLT.
2. AAA application: For the authentication purposes in-between home and radius server. As the authentication succeeds the XOS will be called by an application to spin the services.
3. Multicast: It is used to perform IGMP snooping and to add or to remove the OLP ports to and from multicast groups.

5.5.2 vSG

The vSG consists of the following components:

- a) Introduction
- b) Design Options
- c) Current Design – Functionality
- d) Current Design – Performance
- e) Subscriber API

5.5.2.1 Introduction to vSG

The router at the home of the RG that is a residential gateway that in technical terms is known as the customer premises equipment (CPE) has many functions like NAT, DHCP and it may also perform several services like Firewall, VoIP for the residential customers. With the extension of CPE in the cloud, new value-added services can be provided.

The vSG is the virtualized version of CPE and it runs multiple functions selected by the customer, but this is done in the commodity hardware that is present in the central office in place of the customer home. One CPE is still present in the customer home, but it may be reduced to bare metal switch and the maximum of the functionality that it used to perform to be transferred to the CO and is running on a compute instance that is VM or container on the commodity servers.

5.5.2.2 Design Options

There is a wide range of implementation choices that are provided under CORD architecture. There are two issues with the implementation of it which are:

1. Functionality
2. Performance

There is a northbound interface that is supported by CORD and it allows the customers to select and control particular features. There is another issue which is to map the subscriber bundles to hardware. These include packaging each bundle to its VM. This is about performance.

There are different strategies to implement the bundles which are as follows:

1. The subscriber bundle can be implemented in a Docker container that is running on bare metal.
2. The Docker container that is running in VM there the subscriber bundle can be implemented.
3. The Linux namespace running in VM there the subscriber bundled can be implemented

5.5.2.3 The Design – Functionality

The reference implementation has the support of basic internet connectivity and includes:

1. Suspend/resume: The operators can suspend or resume the customer connection. The container is implemented such that a particular container is suspended from forwarding traffic to the customer.
2. Restriction to access: The access to the customers can be temporarily restricted by the operator. It can be done by using IP tables.
3. Children access limited: parental control.
4. The filtering can be done on the devices that the parents want to restrict at home.
5. Upstream and downstream bandwidth: The upstream and downstream bandwidth available to the customers can be restricted by the operators.
6. Firewall: The firewall to set certain rules for the traffic can be set by both the operators and subscribers.

5.5.2.4 The Design – Performance

The first design was based on the Container in the VM configuration. The challenge was to logically connect the container to the network. In a set of containers, a container is assigned to the subscriber in VM. There are two interfaces in a container the LAN under OLT a WAN under vRouter.

5.5.2.5 Subscriber API

The API is used to adjust the uplink and downlink speeds, parental control on children access and this is the interface to the customer object.

5.5.3 vRouter

5.5.3.1 Introduction

For the necessary routing, we use vRouter in R-cord. Its purpose is to act as a gateway between the upstream and CORD infrastructure. It is the last service for the customer before exiting CORD if logically explained. However, in terms of physical comparison, it is the interface between upstream and CORD. It provides internet access to the central office.

5.5.3.2 Design

For the design of the vRouter it is divided into two main parts:

1. Control Plane
2. Data Plane

5.5.3.3 Control Plane

The main function is the routing protocols concern with the external routers for that purpose Quagga routing stack was used. It supports a variety of routing protocols. It will be using iBGP and OSPF for the upstream routers.

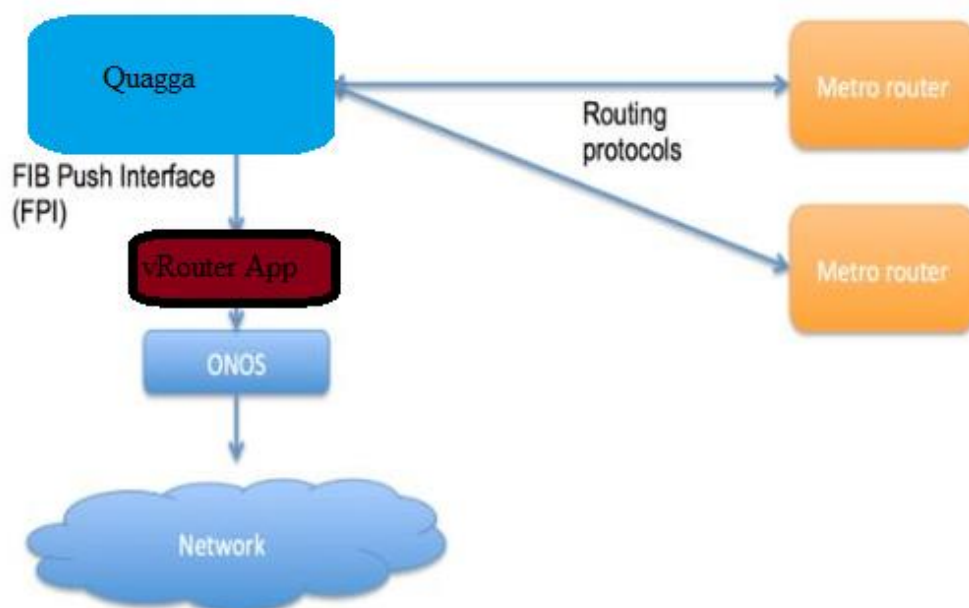

Figure 70: Control plane architecture of the vRouter

Reference: <https://wiki.opencord.org/pages/viewpage.action?pageId=1278093>

Quagga has an interface known as FIB push interface (FPI) that is used to push the routes externally. This I used to communicate the routes from Quagga to ONOS. The ONOS app, in this case, behaves like an FPM (Forwarding plane manager) and can receive and decode the Quagga routes. The vRouter program the data plane according to these routes.

5.5.3.4 Control Traffic

To serve the purpose of Quagga communicating with the upstream routers a routing control traffic needs to be there between a server of Quagga and the external router. So, the data plane

needs to be programmed for the traffic to be allowed to flow. The PIM-SSM for multicast needs to be supported by vRouter.

In order for Quagga to be able to communicate with upstream routers, routing control traffic has to flow between the Quagga server and the external router. Before any routes are exchanged, the first task of the vRouter app is to program the data plane to allow this traffic to flow. The Quagga server is connected to a port on the vRouter data pane, and incoming/outgoing routing packets are directed to/from that port. This bypasses the normal routing task of the vRouter because it concerns control plane traffic that is targeted for the router itself. When there is a need for multicast groups the PIM app will send PIM to join messages.

5.5.3.5 Data plane

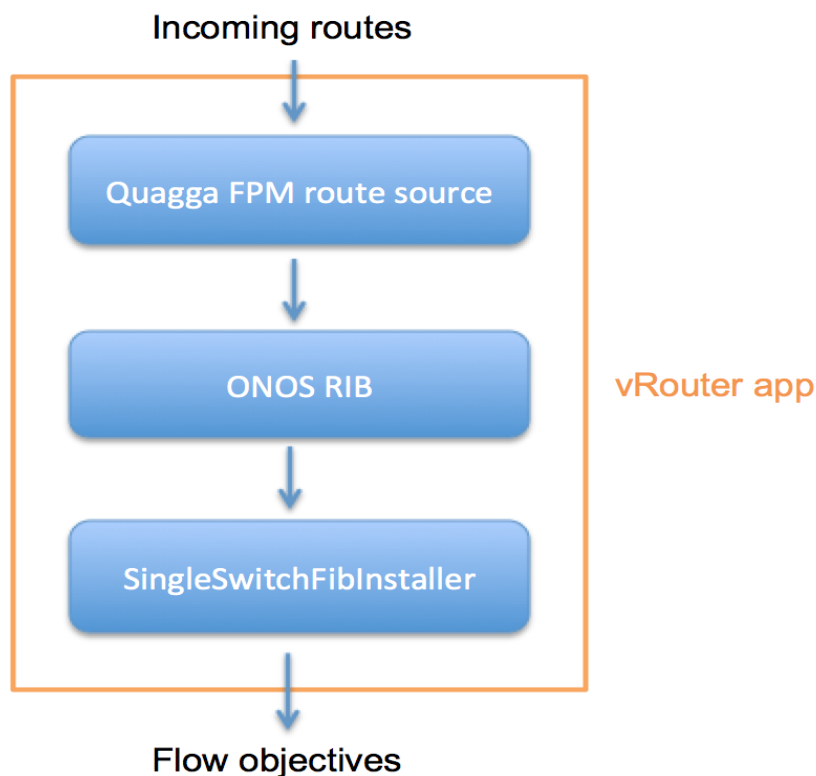

Figure 71: Components that make up the vRouter ONOS app

Reference: <https://wiki.opencord.org/pages/viewpage.action?pageId=1278093>

vRouter does the implementation of the router on the top of the hardware switches. The component named FPM (Forwarding Plane Manager) receives the incoming routes from Quagga. The routes are pushed into ONOS RIB and this component knows how to decode routes. This component generates flow objectives which are then submitted to ONOS.

5.6 DESCRIPTION OF RCORD

Residential CORD

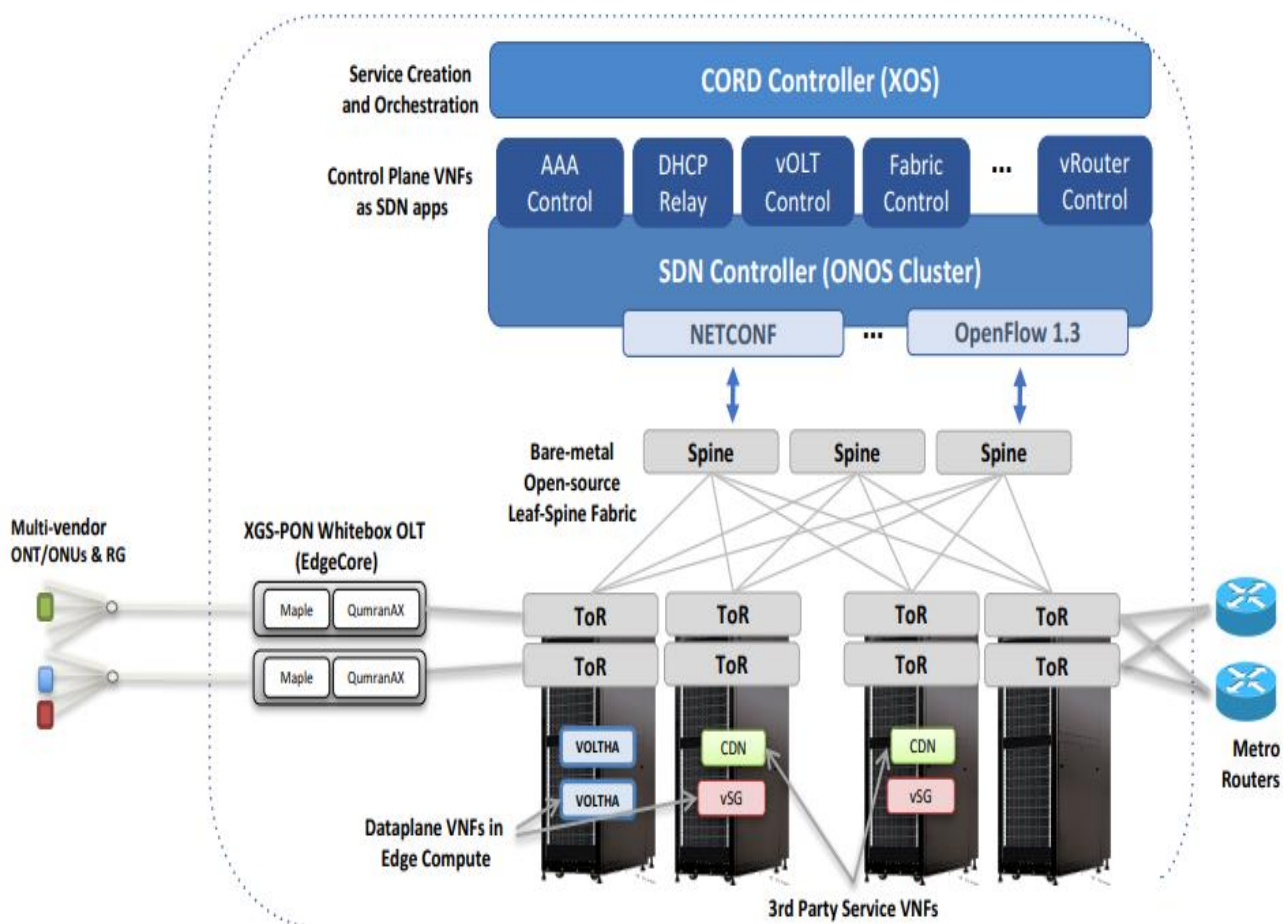

Figure 72: RCORD ARCHITECTURE

Reference: https://opencord.org/wp-content/uploads/2018/01/R-CORD_VOLTHA_Intro-CORDBuild-Day1.pdf

The common infrastructure remains the same for all of them. The above diagram is how the Residential cord looks like it has bare metal switching hardware and open source software. The leaf spine fabric connecting the entire infrastructure whether that is edge computing hardware or there is access hardware on one side going to the Residential subscriber.

On the other side the metro equipment that these central offices connect to each other and to other larger core network for the service provider. So, this is a common club cord platform and it is run by open source software whether it is the SDN controller.

The above is the clustered SDN controller on which there are the whole bunch of apps that run, these apps can be just for the infrastructure itself but there can also be apps that can be meant for the residential subscribers or for providing a particular service.

The VNFs providing a particular service for a particular kind of subscriber could be data plane VNFs.

So, the subscriber traffic is actually going through the VNF or the service can be provided by the hardware itself and is just managed by the application that is running on the top of the SDN controller. The cord controller here is the XOS that manages the entire infrastructure, it is orchestration and also service creation platform.

So, the open source software is managing the entire infrastructure as well as the services for any kind of subscribers running in the compute mode.

The specification of the Residential cord in the above case is that the boxes that are shown above are referred to as the PON (passive optical networks) that are reaching out to the residential subscribers sitting in their homes with optical network units or network terminals.

In the central office is the Optical line terminal (OLT), the head end box of the passive optical network. This is how we reach fiber to home going out to the residential subscribers.

These boxes are new and what is new about these boxes, the same philosophy that we have used in the bare metal hardware silicon running inside the bare metal hardware managed by open source software outside the box what is done with fabric, the exact same thing is done with the access devices in the right.

In the above diagram is the XGS-PON and XGS-PON stands for 10G symmetric PON that means 10G upstream and 10G downstream. This XG has silicon running inside it. There is very little software running inside the box that is actually being managed by the other piece of software that we call VOLTHA.

VOLTHA is outside the box and is managing the Optical line terminals (OLTs) and is also interacting with the SDN controller and the apps that are running on top of it.

Similarly, we have other pieces of software in the data plane, there is VSG that stands for Virtual Subscriber Gateway and there are other third-party services like CDN that we want to provide to residential subscribers.

So, in the nutshell, the CORD network infrastructure and the open source software that is managing the entire infrastructure and then there are set of services that are either SDN apps or they are data plane VNFs that are meant for the residential subscribers.

5.7 VOLTHA



Figure 73: VOLTHA

Reference: Google

VOLTHA stands for Virtual Optical Network Termination Hardware Abstraction. Initially, PON was considered that include the GPON device. The idea behind the VOLTHA is the hardware abstraction that provides technology for the different access networks. The key value of VOLTHA is unified OAM abstraction, is the main value why the service providers are interested in this platform. The service provider wants an access technology that would provide identical control and management interface this a good idea but this is not happening. So the VOLTHA will provide the first step for marching over to that goal.

The idea of VOLTHA is that now we have OLTs from multiple subscribers. The edge core OLT is the bare metal white box OLT we also have a number of other OLTs. VOLTHA creates this common control and management framework for all of the OLTs. It talks northbound to the SDN controller through one of the agents mentioned above and the SDN controller is not PON aware. There is a number of things in the PON like Gem ports, T-cont, OMCI messages between the OLT and the ONU these are abstracted from the SDN controller. The abstraction provided to the SDN controller is not that there is PON, ONU, few OLTs in the house but the abstraction is that it is just an Ethernet switch, pseudo-Ethernet switch.

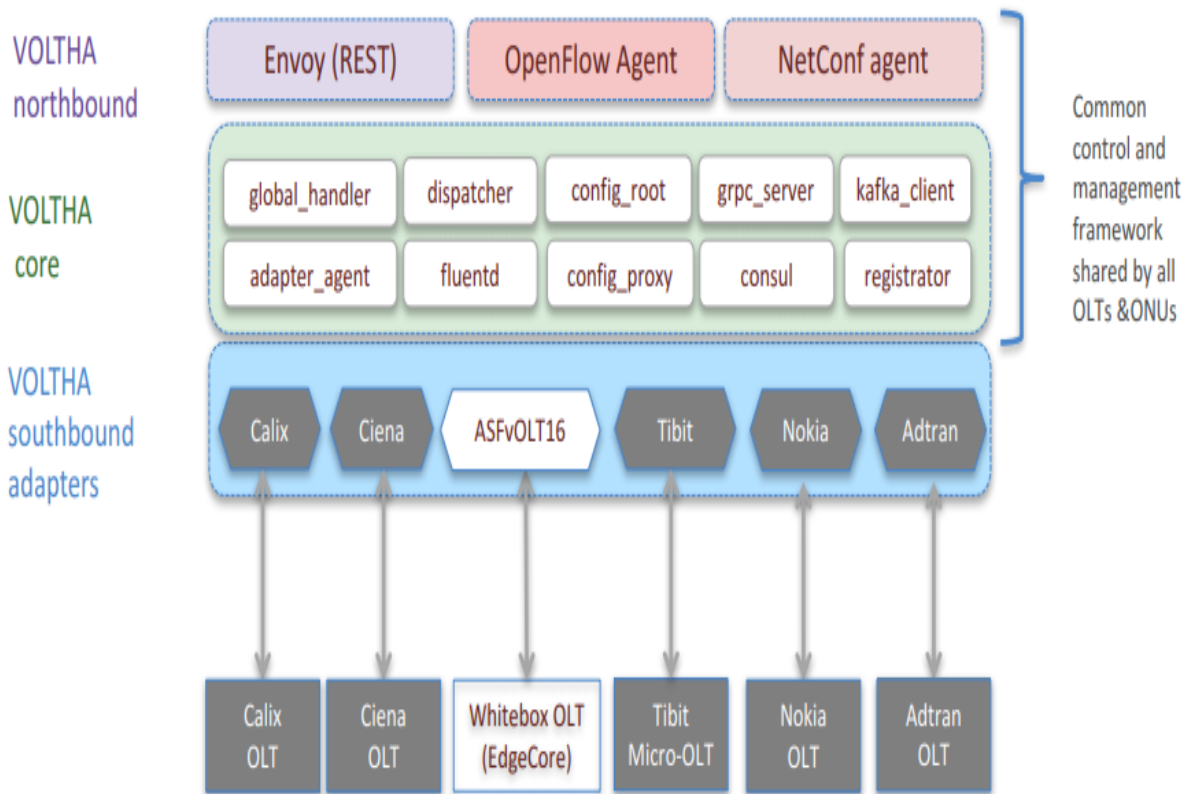

Figure 74: VOLTHA

Reference: https://www.opennetworking.org/wpcontent/uploads/2019/01/Day1_Session8_CO RD-Build.pdf

The SDN controller programs the PON like it will program any other Ethernet switch and then it is the job of the VOLTHA to break up those commands into what goes into the OLT and what goes into ONU maybe through OMCI messages. So, these are the kind of PON level details that are abstracted from the SDN controller. This the first functionality of VOLTHA. The next is that it provides us common control and management frameworks so that whatever comes from the top there is an API and it is the job of the adapters to control and configure the boxes below whether it is the OLT or the ONU.

This is just an example of the demonstration of CORD deployment. So, in this case, we have the head node in which we have ONOS running, XOS, and OpenStack etc. In there, there is only one compute node in which we have VOLTHA running and VOLTHA is managing these OLTs and then we have vSG. These compute nodes are connected to a fabric which is also a white box and is controlled by ONOS. Instead of the full leaf spine fabric, we have a single switch over here that is connecting to the upstream, is connecting to the compute node and to the access devices. The access devices in the demonstration are the one that is the edge core white box OLT and the other one is the Nokia product. Each OLT is connected to the ONUs that are at the residents and to the residential gateway that is providing Wi-Fi access and we have a laptop and other equipment connected over Wi-Fi.

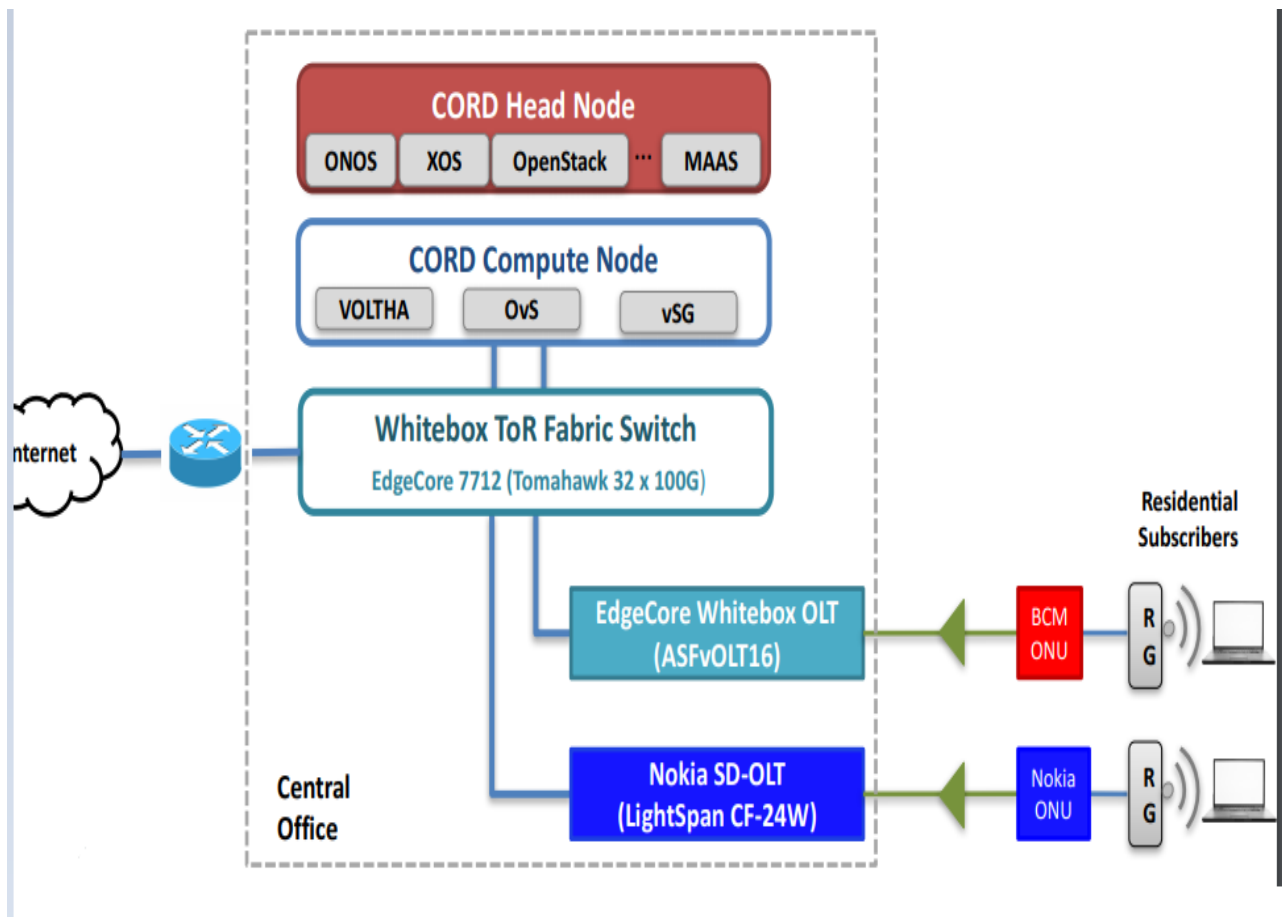

Figure 75: DEMONSTRATION OF CORD DEPLOYMENT

Reference:https://opencord.org/wp-content/uploads/2018/01/R-CORD_VOLTHA_Intro-CORDBuild-Day1

5.7.1 HOW IT WORKS

Suppose we bring up a subscriber let's say a subscriber came up at home and we activated the ONU and the first step after it is to authenticate the residential gateway that is sitting behind the ONU. So, the authentication step happens like this when we activate this, ONOS goes ahead and via VOLTHA programs the box to say that if we see authentication packets send them up to me.

So, when the authentication packets come they go not through the data plane but through the compute node and then onto the VOLTHA and to the ONOS. What ONOS does there is a triple play app written on it that sends it to the radio server to get authenticated. If the authentication fails the traffic from that particular ONU will be blocked.

If the authentication succeeds there are a number of things that happen:

First of all, we want to provision some VLANs for that particular subscriber. So, there is a subscriber VLAN, a CVLAN then the service provider VLAN that is SVLAN that gets allocated that is told to VOLTHA and then VOLTHA in turn either tells the OLT to put the SVLAN and ONU to put in the CVLAN. At the same time, ONOS also tells the white box

fabric that is going to forward those VLANs to the compute node tells the virtual switch inside the compute node to forward those VLANs as well to the vSG that XOS has created via open source stack for that particular subscriber. There is a number of things that are happening as soon as the subscriber is authenticated.

5.7.2 DATA TRAFFIC

How does the data plane traffic then goes through?

The data plane traffic takes exactly the step, gets the CVLAN, SVLAN forward it through the fabric through the virtual switch and then onto the vSG for that particular fiber and then goes back to the internet. If that traffic was meant for the internet that is exactly the steps it would take. But the purpose of it going through the vSG that stands for Virtual subscriber gateway is that it is a gateway for additional services that we might want to provide for the particular residential subscriber. For example, I am at home I can go the subscriber portal and then I can change and do parental control over there. Suppose I have a child at home and I do not want the child to mistakenly go to some adult websites so I can go to the subscriber portal where I can see the devices that are in my home and for the particular device I am going to do some parental control so what happens at the backend is that this goes to the XOS and XOS figures out that this is the vSG for this particular subscriber and for that particular device that requires parental control I am going to change the access controls inside the vSG so when such traffic does show up it gets blocked at the vSG and so there are other services that we can provide in a similar way.

For example, now if I want to go on the operator view instead of subscriber view now operator can describe, I am going to block this subscriber because of whatever reason like it hasn't paid the bill or any other reason or I can say that there is traffic that is better being served by CDN which is at that edge compute not somewhere far away sitting on the internet. The CDN is at the edge compute and so if I will take the subscriber traffic and service it through the CDN. So, it's essentially our subscriber's gateway.

CHAPTER 6

SDN AND NFV

6.1 INTRODUCTION

For the world today the most important aspect is survival of the fittest for every field and so is the case with the communication industry. Now the world believes in virtualization and all the traditional telecommunications strategies are going through multiple stages of digital transformations with the network virtualization. Now the trend in all the vendors is to evaluate the upcoming services like network as service, SDN (Software-Defined Networking) or the virtual network functions to legalize their network.

Software Defined Networking (SDN) and Network Functions Virtualization (NFV) are of taken under great interest due to their flexibility and are adaptable to the services that are required and to the subscriber's needs.

These concepts are however widely used in the datacenters and comparatively, it has less consideration for FTTH networks.

Persistent market advancement changes how customers, ventures, and machines will utilize these new systems, a comparable if not worse advancement and more client experience will likewise be expected. Unfortunately, the time expected to develop, and dispatch new services is unsatisfactorily moderate in most scenarios because of network infrastructure only suitable for hardware. As cable operators hope to improve, organize infrastructure advancement is a central transformational objective.

The cable operators yet have a smart approach of waiting and watching the initial transitions of the SDN and NFV they wait to see what all changes does it bring to move from the fixed mobile challenge to the virtual service. It is a result of the customers increasing demands that have led to force the cable operator to offer some incentive, cost, and experience that will keep clients associated.

With the wireless operators providing the resources into 5G systems with gigabit able transmission capacity and the over-the-top (OTT) suppliers keep on picking administration innovativeness that fuses on-request and accomplice conveyed administrations is one of the main approaches to keep a focused position.

The recent action of the cable operators is to begin its very own adventure towards SDN and NFV and, sometimes, is demonstrating development towards the grasp of innovation that will prompt the virtualization of access systems. The endeavors of both Cable operators to drive innovation models forward have been significant to the development of the business toward a more aggressive competition. This development of the operators to push more capabilities toward the network edge will bring more innovations.

For the better customer experience and to provide them with more benefits the operators have

replaced the boxes and are searching for the options that will provide the virtualization. There are multiple ways in which the SDN and NFV can be adopted and will lead to a better experience for the customers. So, the edge will have more flexibility.

The best movement for them is the more noteworthy knowledge at the edge that depends on two virtualization techniques:

1. CORD

2. HERD

The increased demand of the bandwidth has led to the network operators in thinking a better solution, so the commodity infrastructure was taken under consideration there came the thought of the CORD at the Open Networking Summit. CORD, or Central Office Re-architected as a Data Center is the architecture of the telecommunications virtualization of the Telco Central office that has brought together SDN/NFV together with the cloud technology and has provided the central office with the ability to change as per required demands. So, we can say that the central office more likely has the ability to provide the services as per the demands. It can provide new services as per the requirement of the consumer at a particular time.

In the common cases of the virtualization, the providers have the benefit to leverage the hardware as well as the software infrastructure that supports the traditional connections and also the cloud service benefits for RCORD, ECORD, and MCORD. The cloud-based model additionally opens the conveyance alternatives to outside accomplices, who can more effectively offer corresponding services to their normal clients with an assortment of organization models. This thus implies quicker time-to-service and time-to-income.

The hardware of the CORD has commodity servers that are connected with the help of white box switches. For the traffic going from east to west, the switching fabric is used whereas there is no traffic flow from north to south. The open software is placed as the substitute of racks of GPON OLT MAC.

The central office of CORD that is changed has two parts. In the first part there are virtualized hardware devices and on the commodity hardware, the software counterpart is produced. In the second part, there is a framework that can be used by the counterparts of the software to plug in in order to complete the end to end system. Like the hardware, the software counterparts together should also fit in a coherent way.

So, CORD is an integration of three parts that are SDN, NFV and cloud services. Their function overall in a single line if explained is as follows:

- The network can be controlled with the help of Application program interfaces or open program interfaces with the help of SDN.
- The purpose for which NFV is used to decouple the software from hardware.

- In the last is the cloud that is used that can provide the operators with multiple software-based platforms.

The second virtualization technique is called HERD (Head End Re-architected as Datacenter) and this is specifically in the cable of the CORD which is a further expansion for the positive point of virtualization that results in providing capacity and smartness to the edge. The purpose of using virtualization is to have maximum performance for streaming videos. The most relevant aspect is how much is the ability to cache videos this will lead to the advancement of the user experience as the cached video will be stored in the local servers that will result in increased speed and reduced latency.

With the cloud-based data center, the cable providers have the benefit that will provide a competitive edge that will have the innovation of service, increased bandwidth leading to increased speed and good quality of service that will make the consumers satisfied that is finally what the motive to stay in business is. As well as if the fiber that is placed near the homes will increase the capacity that will make it another plus point towards the innovation and better quality.

The wireless telecommunication is giving a tough competition with the 5G and at this moment the cable operators providing the step of the virtualization is a healthy step to maintain in competition. However, we cannot turn our faces opposite to the reality which says that 5G by now is a reality, not a myth what that means is cable providers has to come with an approach that will be more creative. Innovation drove administration advancement, regardless of whether by means of programming decoupling or client specific administration groups, will empower better approaches to give clients what they need, convey a customized involvement and have the fundamental experience to react to advertise changes continuously. Like the case as it's simpler to shop at a nearby supermarket than a single path to town, it's less demanding for cable suppliers to convey its services starting from the head-end to the street as opposed to from an arbitrary datacenter in the cloud that could be several miles away.

6.2 FUNDAMENTALS OF SDN AND NFV

The SDN is a typical example that specifies the separation of two planes that are control and data plane. When the control and data plane will be separated that means now the hardware and software are independent of each other.

SDN is more into action and is adopted by operators and customers since it provides direct control of the routes that are taken by packets. With that, there is more help for the networks to respond quickly as the demand changes and according to the applications that run on the top. The NFV separates the network functions from the hardware so that it enables the network functions to become mobile.

For its purpose to serve in the datacenters and the WANs is to separate the two planes that are the control and the forwarding plane. This can be achieved with a control protocol that is generally used for changing the behavior of the forwarding plane. The network operator should

not face the difficulty of accessing the network's complexity regularly. In particular that means that the control should have the end to end connectivity based on high-level policies.

So, the controller is the SDN controller that would have the network broad view and can accordingly improve the traffic flow and increase the performance.

It is the SDN controller that has a broad view of the network and can optimize the flow of traffic to improve the performance and utilization of the network. The packets are of less concern as compare to hardware automation and the logic of features that governs the behavior of network devices.

For the overall performance of the fiber access network, the disaggregation of the layers is done it might shift the control functions from hardware to software but with this, we got an improvement.

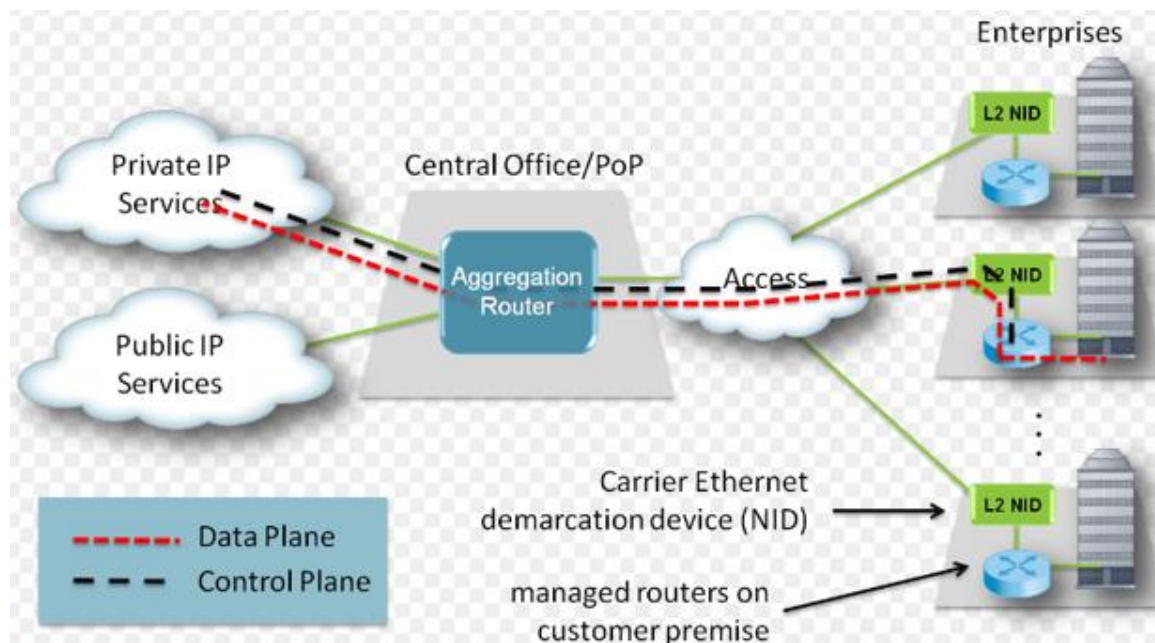

Figure 76: DATA AND CONTROL PLANE

Reference:<https://www.sdxcentral.com/articles/contributed/nfv-and-sdn-whats-the-difference/2013/03/>

The Access Network has a vital role to play in providing services to subscribers. As the demand for the cloud services is increasing day by day so is the need for reliable service to the customers has increased.

As of now presented previously, SDN and NFV are considered independent, however, there are numerous cases in which the two ideas are exceedingly interconnected between one another. As a perspective, NFV isn't subject to SDN. For instance, SDN is completely there to fulfill the demands of NFV when it needs orchestration and coordination models. The controller can instantiate a VNF based on explicit necessities.

NFV vs SDN

Software Defined Networking (SDN)		Network Function Virtualization (NFV)
Separate control and data, centralize control and programmability of network	Basic Concept	Relocate network functions from dedicated appliances to generic servers
Campus, data center / cloud	Target Location	Service provider network
Commodity servers and switches	Target Devices	Commodity servers and switches
Cloud orchestration and networking	Initial Applications	Routers, firewalls, gateways, CDN, WAN accelerators, SLA assurance
OpenFlow	New Protocols	None
Open Networking Foundation (ONF)	Formalization	ETSI NFV Working Group

Figure 77: NFV vs SDN

Reference: <https://favouriteblog.com/difference-between-sdn-nfv/>

6.3 SDN

In the past several years' Software Defined Networking has become the central considerable point for almost every computer industry. This is because for a network it reduces the CAPEX and OPEX that is Capital expenses of network resources and the operational and maintenance cost respectively this is what is the requirement of every network industry.

After, the question that arises is what the actual cause of the demand of the SDN that is making it so special. The answer to the question is traditional network was not able to survive with the upcoming traditions that are dynamic scalability, core management, less manual efforts, high speed to reduce the jitter in traffic, virtualization traffic.

The Open Networking Foundation (ONF) is the responsible group that looks after the improvement and standardization of SDN. As indicated by the ONF, "Software Defined Networking (SDN) is a developing technology that is dynamic, sensible, savvy, and versatile, making it perfect for the high-data transmission, dynamic nature of the present applications. This design decouples the system control and forwarding capacities empowering the system control to end up straightforwardly programmable and the foundation to be abstracted for applications and system administrations. The OpenFlow convention is a basic component for building SDN arrangements.

The traditional networks were limited to highly expensive elements which do not allow the internals to customize. So, to deal with these issues open source communities together got a solution for defining an approach for this. So, then came the concept of SDN.

According to ONF the SDN has the following features:

- It can be programmed directly
- It can move easily and quickly
- It can be managed centrally
- It can be configured with the help of the program
- It is based on an open standard

After that, the SDN has now evolved over time. As the name depicts the SDN is based upon software implementation. As it is a software layer it has many benefits such as there is a reduction in manual effort and management of device is of the network. For the proof, we can consider the fact that in traditional networks every network device has to set up manually in a datacenter the or an enterprise. So, humans make mistakes that mean it has more exposure to errors as well as whenever there is a change in the network it requires manual reconfiguration that it is a highly time-consuming task.

At the same time on the opposite, an aspect we have SDN that expects to have an all-encompassing perspective on the system, very easily from the central point we can access and investigate the devices that reduce the human efforts which lead the reduction in costs and time. The software layer is virtual so the network that is running on top of it is also virtual and physical networks are mapped.

As the server virtualization has helped a lot in storing and computing virtually so does there was a need for network virtualization for the utilization of resources and better performance. The core issue that is focused on and solved by the SDN is that the previous networks were very costly with more features but were never fully utilized. So, if someone will ask me to explain the SDN in just a single line it is the one in which we separate the control and the data plane in the previous network.

The control plane in the network is known as an intelligent logic since it is responsible for the data flow that is how to manage it. Data plane on the other side is known as a forwarding plane in this the network traffic must be forwarded or dropped as per the condition.

So, if I have to explain about the tasks of the control plane that are as follows:

- The decision about where to send the traffic is made by this plane.
- The traffic of the control plane is taken under consideration by the router that is used to decide where should be the destination of it.
- The routing table information is also the task of the control plane also how to configure the system and how to manage it.
- The controller is responsible to exchange the information with all the routers that are involved in order to build a routing table that is dependent upon the routing protocol that can be RIP, BGP, and OSPF.
- The packets of the control plane are used for updating the routing table.

- In this, there is no time and speed constraint since these functions are not individually performed on every packet.

The tasks of the Data Plane are as follows:

- It is the forwarding plane that is used to forward traffic along the path that is selected to forward it to the destination according to the path that is selected by the control plane.
- The packets are forwarded via a router and it follows the path and everything for the outgoing and the receiving packets.

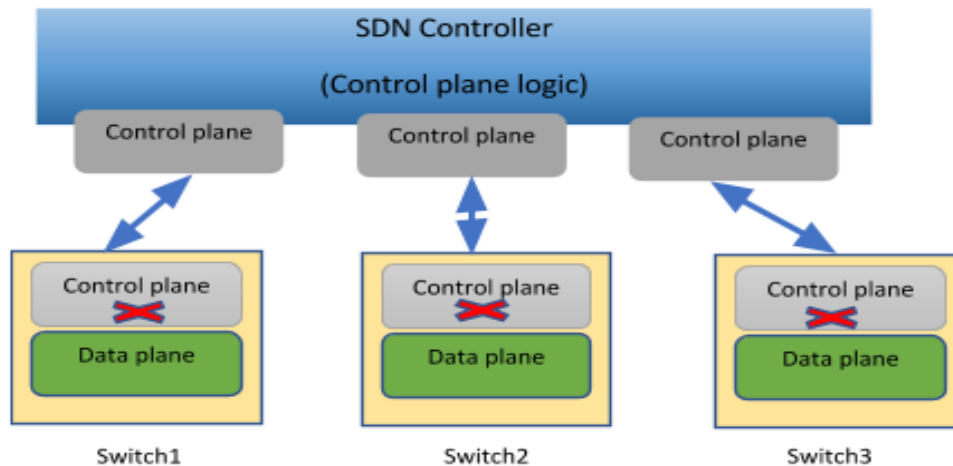

Figure79: Separation of control plane into the controller

Reference:<https://www.howtoforge.com/images/how-to-compare-files-and-directories-in-linux-using-beyond-compare/big/sdn-basic-architecture.png>

The separation of control plane into controller has the following benefits:

- From the controller, we can configure and troubleshoot network and can see the full topology.
- Through the protocols the underlying network elements can be controlled by the controller and control plane is residing in it.
- Virtualization of system prompts multi-tenancy which thus enables influence to the maximum capacity of system components. SDN controller can digest hidden physical system and permit administrator to program virtual systems relating to each occupant. A genuine case of a spot where virtualization is utilized is server data center - the design is utilized to share normal physical system among numerous clients.

6.3.1 The SDN ARCHITECTURE

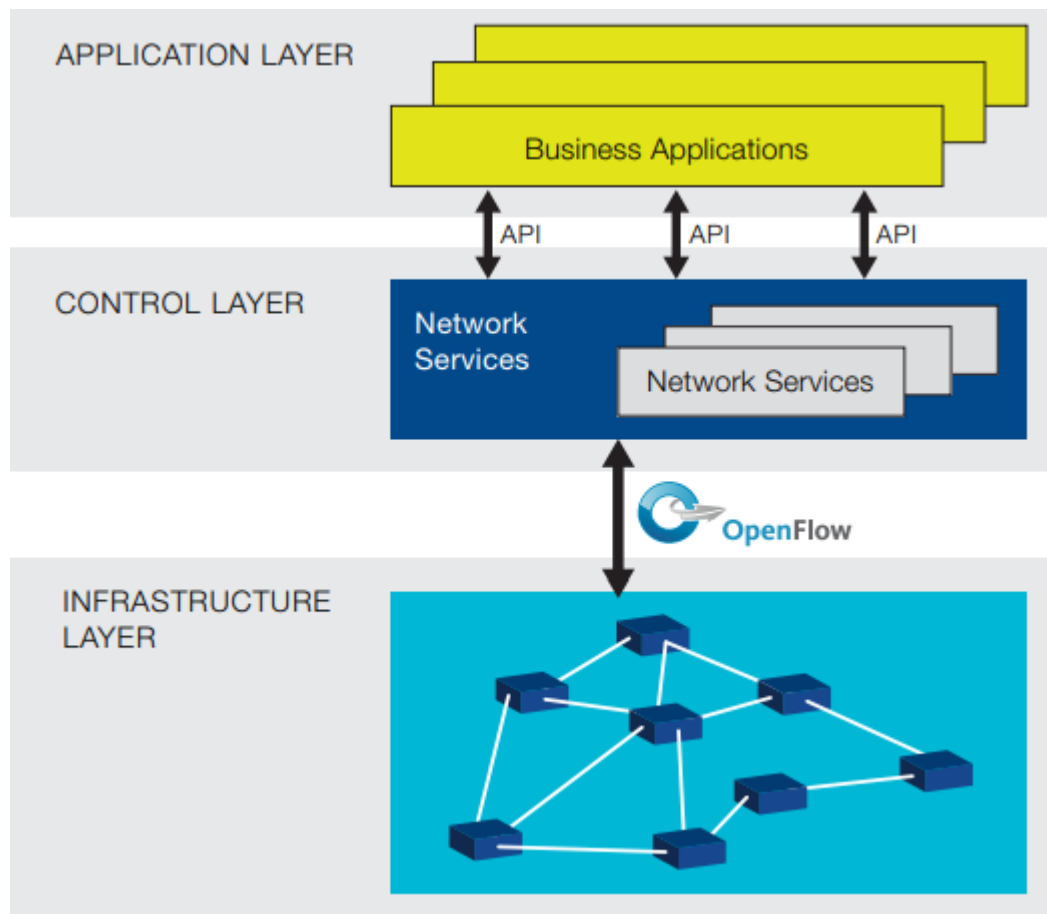

Figure 80: ONF SDN ARCHITECTURE

Reference:<https://www.opennetworking.org/images/stories/downloads/sdn-resources/solution-briefs/sb-sdn-nvf-solution.pdf>

In the diagram above, the infrastructure layer is considered as the virtual switch that is inside a hypervisor. It will be alluded to as the overlay-based model. In different implementations, the infrastructure layer is a blend of virtual and physical devices. This will be alluded to as either the underlay or fabric-based model.

There are three types of layers in the ONF/SDN:

1. Application Layer

The Application Layer comprises of the user end business applications that expend the SDN administrations. The limit between the Application Layer and the Control Layer is crossed by the northbound API.

2. Control Layer

With the help of an open interface, the control layer gives the centralized useful functionality that takes care of the forwarding behavior of the network.

3. Infrastructure Layer

The Infrastructure Layer comprises of the network components (NE) and components that is used to switch and forward the packet.

6.3.2 The working of SDN

The providers supply with a wide range of designs yet at its most straightforward, the product characterized organizing strategy brings together control of the system by isolating the control logic from the resources that are off device. Every SDN solutions have a version for controller in addition to southbound API and northbound API which are as follows:

Controller: The controller as the name depicts is the network brain. With its help, the forwarding plane has a transparent view of how the traffic of the network can be handled. It helps to view the whole network.

Southbound API: Southbound API is used by SDN for the below switches and routers to relay information to them. It stays as one of the common protocols and was the first standard considered by OpenFlow.

Northbound API: Northbound API is used by SDN for the above business and application purposes. These provide the operators to provide shape to traffic and program it.

As indicated by the model, an SDN infrastructure is displayed by three key traits:

- **Central Intelligence:** In the ONF SDN design, network control is spread from sending through a conventional southbound interface OpenFlow. By incorporating system knowledge, basic leadership is encouraged transparent perspective on the system, instead of the present systems, which are based on a self-governing framework see where nodes are uninformed of the general condition of the network.
- **Programmability:** SDN systems are characteristically constrained by software, which might be given by suppliers or the system administrates themselves. Such programmability empowers network design to be automated, impacted by fast utilization of the cloud. By giving open APIs to applications to communicate with the system, SDN systems can accomplish exceptional development.
- **Abstraction:** In SDN, the business applications that expend SDN administrations are abstracted from the basic system advances. System gadgets are likewise abstracted from the SDN Control Layer to guarantee versatility and future-sealing of investments in system benefits, the system software occupant in the Control Layer.

6.4 NFV

In the year 2012, more than twenty of the world's most renowned telecommunications specialist organizations shaped an Industry Specification Group (ISG) inside the European Telecommunications Standards Institute (ETSI) to characterize Network Functions Virtualization (NFV). From that point forward, the NFV activity has produced a lot of

enthusiasm, including in total of 28 arrange administrators and more than 150 innovation suppliers from over the telecommunications industry.

The NFV startup is planned to address the operational difficulties and staggering expenses of dealing with the proprietary that are all overused in telecom systems. By virtualizing and combining system works generally executed in committed hardware, utilizing cloud advances, arrange administrators hope to accomplish agility and quicken new administration deployments while reducing both (OpEx) and (CapEx).

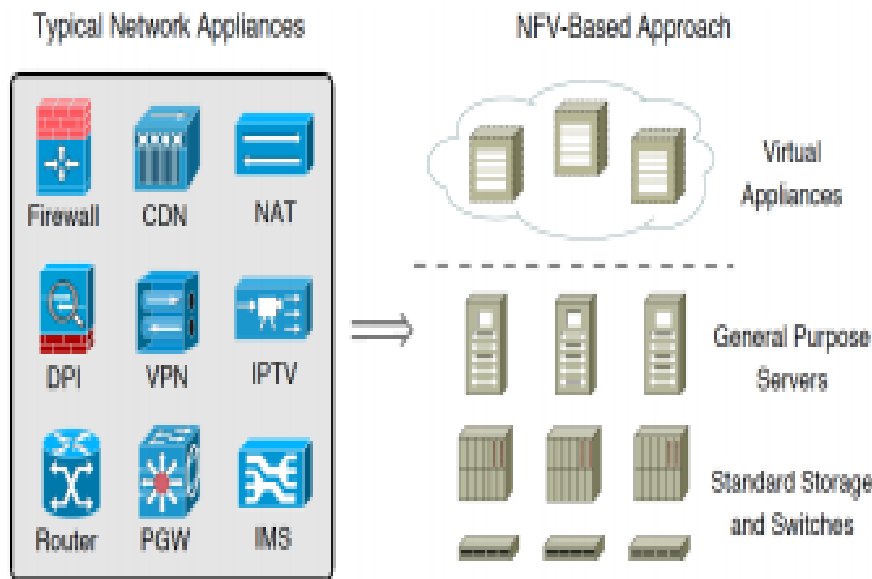

Figure 81: From dedicated hardware-based appliances for network services to

Reference:<https://wiki.aalto.fi/download/attachments/109392027/Software%20Defined%20Networking%20and%20Network%20Function%20Virtualization%20bridging%20the%20world%20of%20virtual%20networks.pdf?version=3&modificationDate=1450355563765&api=v2>

With the conventional systems when the packets of data from the customer side are sent to the router it then goes through various boxes that perform additional functions. So, the virtualization will focus on the cost to reduce the hardware as well as provide faster service.

NFV at present is possible only because of all the technical advancements that are coming up. For the fully utilization and development of NFV there are three main factors that will be considered that are as follows:

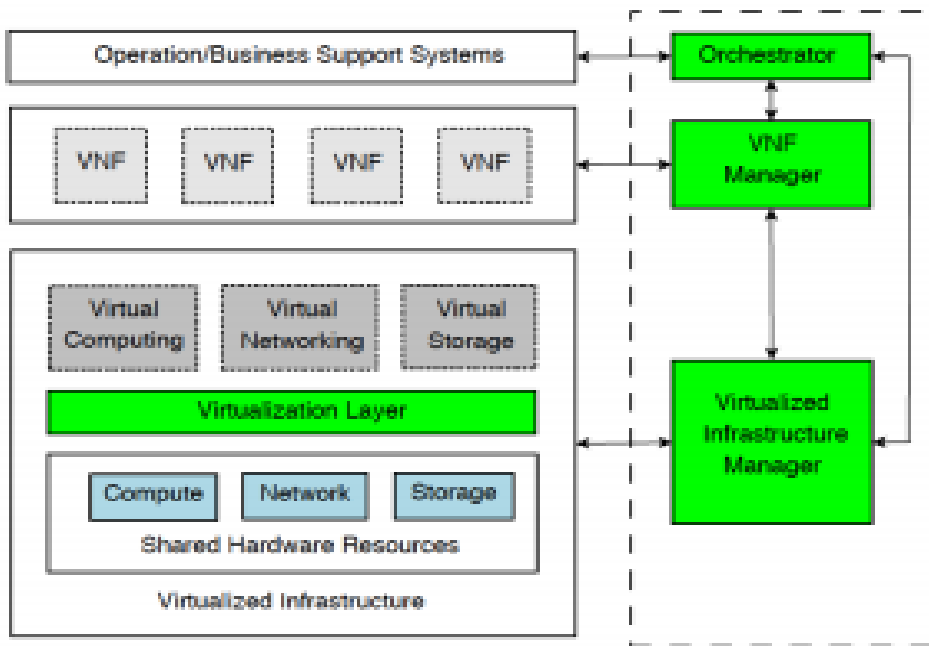

Figure 82: NFV architectural framework

Reference: <https://wiki.aalto.fi/download/attachments/109392027/Software%20Defined%20Networking%20and%20Network%20Function%20Virtualization%20bridging%20the%20world%20of%20virtual%20networks.pdf?version=3&modificationDate=1450355563765&api=v2>

1. Virtualization
2. Orchestration
3. Automation

1. Virtualization

Service operators need to take some crucial steps, as the software will run on COTS hardware so, there is an abstraction. There are few functions that will have benefits from the COTS hardware whereas, on the other hand, some will be better with the help of dedicated hardware.

VNF manager oversees the events, updating, and termination of every VNF that is active or running at a time.

Virtualized Infrastructure Manager manages the activities that are linked with the virtualization layer. This layer is responsible for the configuration of the network compute and resources storage, for virtualization and to monitor the interaction with VNFs. If there is any issue with the performance that is checked by it.

The way to full NFV may pursue various strides as frameworks advance:

- Virtualized programming running in a static mode on a characterized COTS equipment and programming build
- Virtualized programming capacities on any COTS or other specific virtual servers with physically activated scaling

- Full cloud execution with auto scaling, strength and open APIs that empower dynamic administration initiation by third parties, including control of center system capacities
- When settling on a choice on which venture to take first, the end diversion ought to be in sight or it might defer different choices later on.

2. Orchestration

The orchestration and the executives of virtual machines should be done in different style in a telecom industry than a normal data center. Regardless of whether the specialist is putting forth a portable application or continuous voice inside a Web application, there will be numerous software schedules all interconnected and shared.

Every software module is transferred onto a virtual machine image inside a server. Thus, the telecom space requires many virtual machines, which for reasons of strength and SLA uprightness might be broadly disseminated. Dealing with the dispersion to guarantee administration execution requires a higher level of orchestration.

The orchestrator computerizes the way toward planning and following virtual machines inside the specific data center. Every telecom operator requires an alternate virtual machine setup and design. Through formats and formulas, the orchestrator realizes the design required to help every application. At the point when another capacity and additionally greater ability is required, an accessible virtual machine will be found and made accessible with the right arrangement.

The orchestrator oversees the lifecycle management and its facilitated capacity, including the formation of VM profiles and a wide assortment of different capacities. The business still needs to meet on a common apparatus to make the VNF profiles.

QOS measurements should likewise be standardized to guarantee that when application execution is estimated and checked the execution is considered against a reliable measurement and proper moves are made to improve the measurement.

3. Automation

As NFV scales, the administrator must simultaneously deal with the basic system foundation. To do this expense viably, it is important to automate the system to guarantee it is in venture with application request. This is the job of SDN. SDN at present is configured in the data centers where an overlay control layer is demonstrating its part to satisfy the systems administration needs of the quickly rising number of virtual machines. In these arrangements, SDN guarantees that network associations can be made as quick as the virtual machines inside a server are made. The deployment of cloud computing inside telecom systems moreover brings a lot shorter administration lifecycles joined with expanded application portability.

Hence, in comparison to the data center, the WAN here is more dynamic. Selection of SDN inside the WAN will improve the asset and capacity via computerizing alterations dependent on real time utilization. A completely powerful system will be accomplished by executing NFV

and SDN over traditional programmable optical system fabric to scale application and system execution when and where it's required.

6.5 THE ROLE OF SDN AND NFV IN RCORD

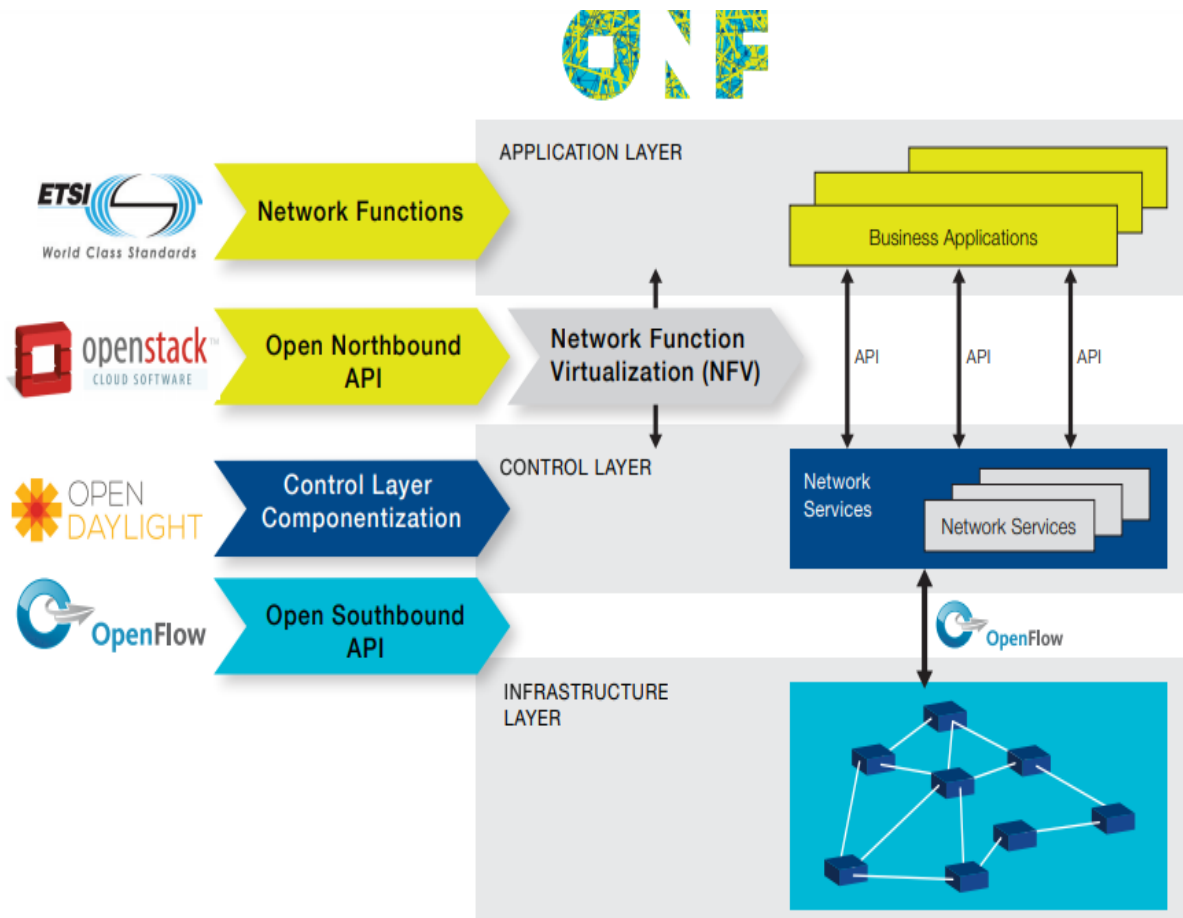

Figure 83: NFV and SDN Industry

Reference:<https://www.opennetworking.org/images/stories/downloads/sdnresources/solution-briefs/sb-sdn-nfv-solution.pdf>

To reduce costs and better access a cloud based virtualized network is required. Virtualization is the concept in which the software applications running on the commodity hardware performs the functions that were performed by dedicated hardware's in traditional networks. SDN and NFV's combination allow the network operators to leave the traditional network and use the new model that is virtualized. It segregates the control and forwarding plane that ends up with central control and improves throughput.

NFV starts by the conversion of traditional hardware into software programs and these software run on COTS hardware. These infrastructure helps in increasing the capacity as well as it is like a pool of resources. NFV has many components like vOLT, vCCAP and vBBU. SDN and SDWAN has evolved really well and is still expecting a great raise in the coming years.

SDN and NFV have a real important role behind the idea of the RCORD.

CLASSICAL APPROACH WITH PROPRIETARY NETWORK APPLIANCES

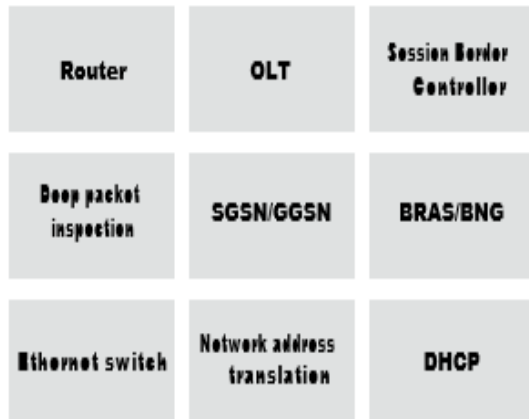

OPEN, VIRTUALIZED APPROACH WITH SDN/NFV

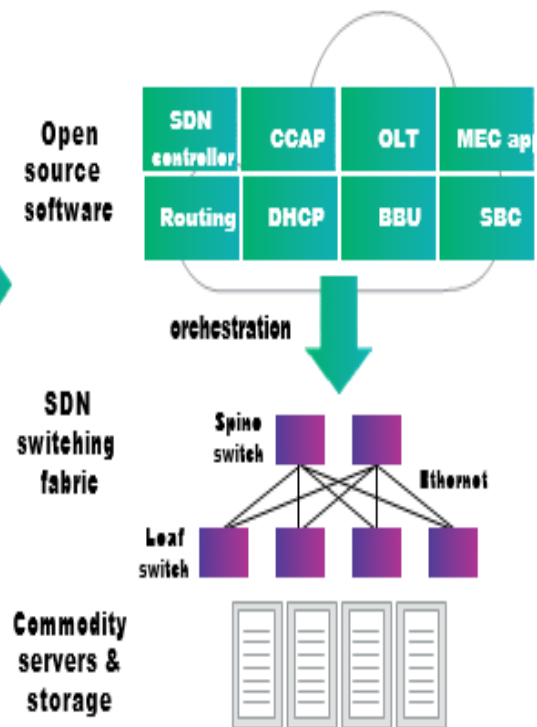

Figure 774: From proprietary appliances to an open, virtualized environment

Reference:https://webcache.googleusercontent.com/search?q=cache:ZSNWoVmQH-UJ:https://www.commscope.com/Docs/How_CORD_will_impact_your_central_office_WP-112415-EN.pdf+&cd=9&hl=en&ct=clnk&gl=ca

These technologies will provide with the best automation, faster services, revenue increases steadily and lower operational and maintenance costs higher management.

NFV plans to lessen hardware expenses and reduce time to showcase while achieving adaptability, flexibility, and a solid biological system. The Open Networking Foundation is seeking after comparable objectives through OpenFlow-empowered SDN. Similar to NFV, SDN quickens development by breaking the bond between hardware and software.

Both NFV and SDN look to use computerization and virtualization to accomplish agility while diminishing both OpEx and CapEx. Though NFV is expected to optimize the capacities, SDN is engaged with respect to improving the fundamental systems. The two bodies are driven by a solid user end culture. Arrangement of NFV requires huge scale dynamic system network both in the physical and virtual layers.

Conveying another service in an extensive network arrangement is a long and burdensome procedure. It too requires long cycles of approval, testing and pilots to resolve issues and glitches. Via mechanizing the administration and coordination of the NFVI, time to showcase for setup changes for newer services will be essentially decreased with OpenFlow-based

SDN/NFV. Also, a virtualized framework for both NFV and SDN encourages strategies, where programming changes can be deliberately tried on the genuine NFVI before being deployed without affecting the operational system.

OpenFlow-based SDN is rising as a fundamental datacenter innovation, and an extraordinary empowering influence for NFV and bearer systems. ONF is focused on an open SDN design, with various activities in progress to address the particular requirements for the transporters. These activities incorporate a carrier arrange discourse gathering to address general carrier SDN problems, also, a relocation working gathering to examine the accepted procedures for moving to OpenFlow-empowered SDN.

CHAPTER 7

Selection of Neighborhood

7.1 DIAGRAM OF CITY OF LEDUC

For the implementation of both the GPON and the RCORD based FTTH network, I have chosen the City of Leduc for my project.

The diagram below is of the City of Leduc area:

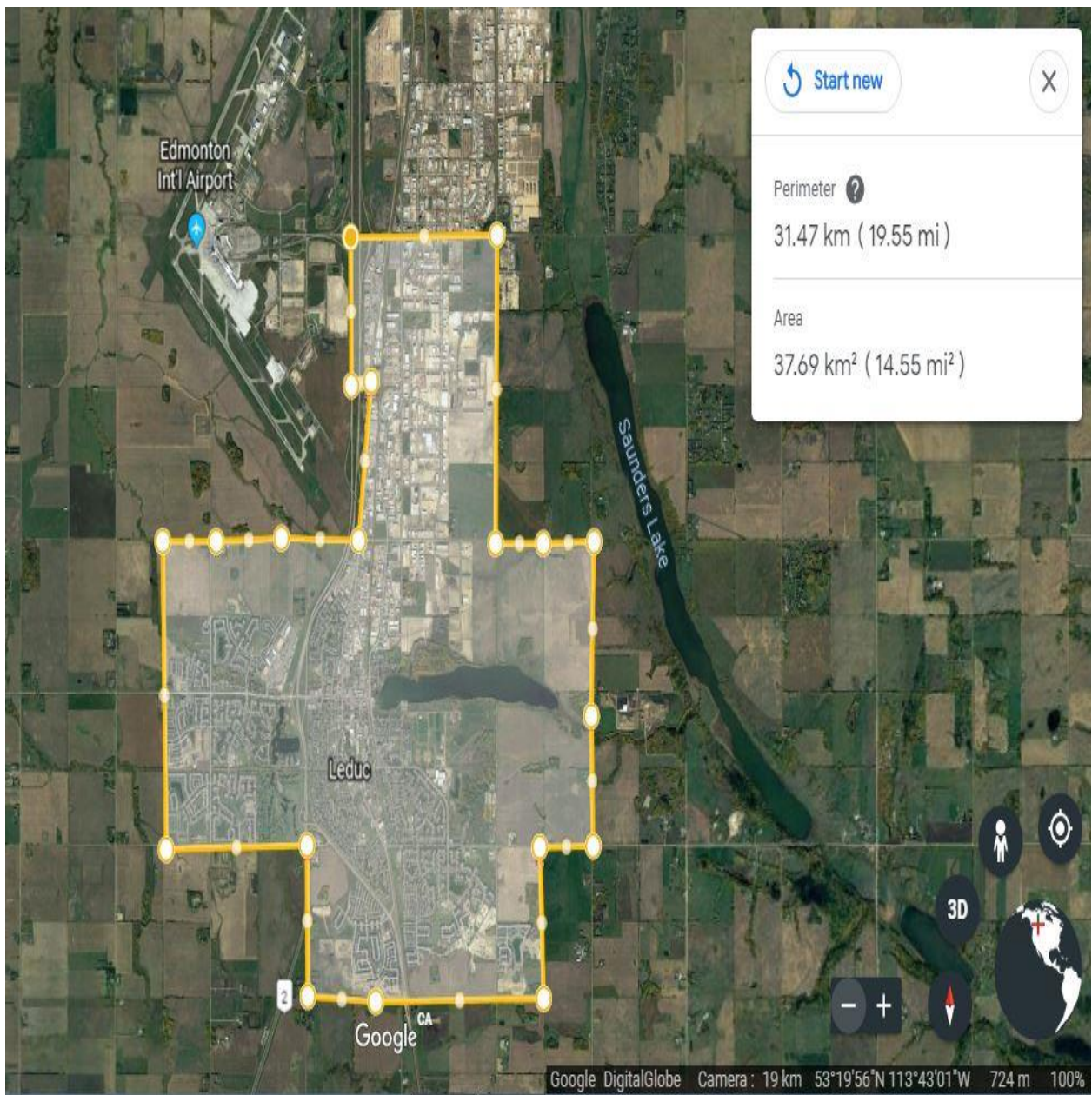
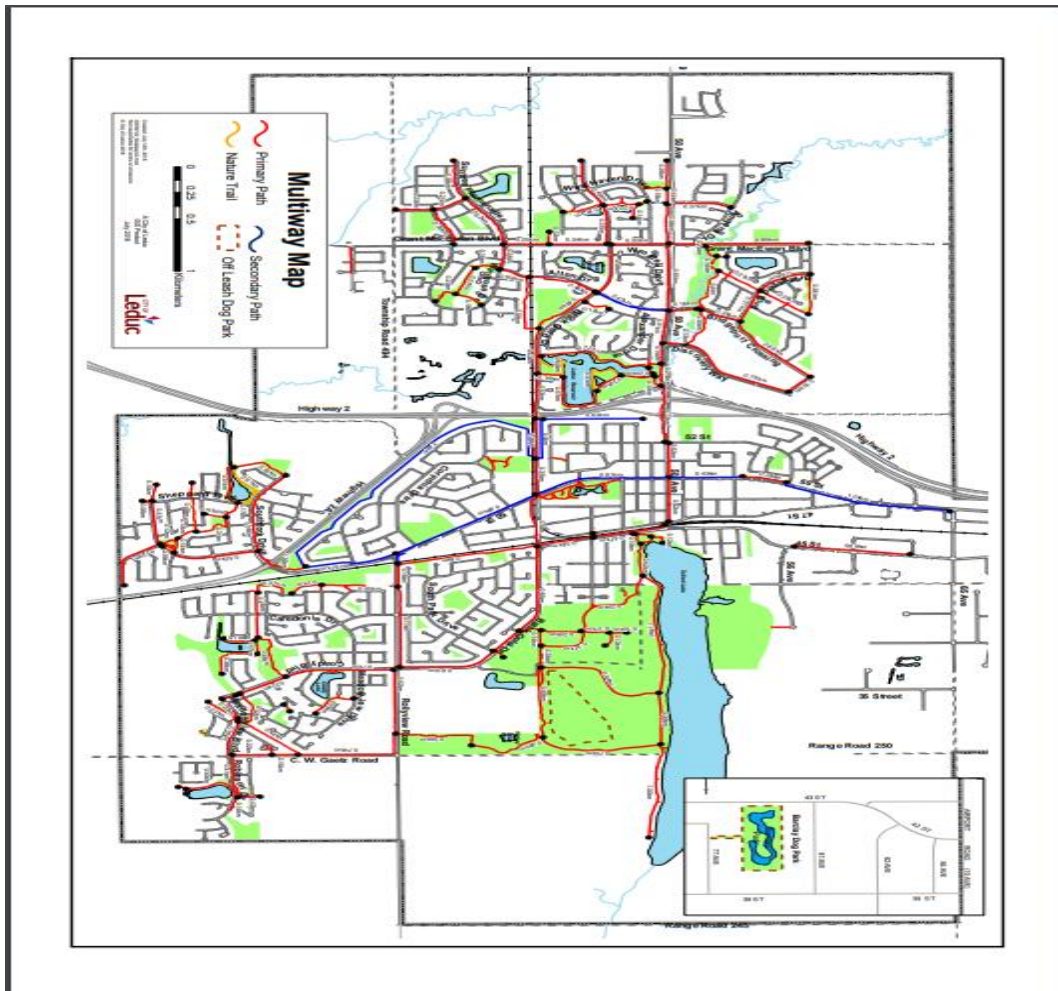

Figure 85: CITY OF LEDUC

Reference: Google

7.2 MULTIWAY MAP

Multiway Map of the City to analyze the length of the cables required to create a network:



7.3 Details of the City of Leduc

Reference <https://www.leduc-county.com/services/roads>

Area: 37.69 sq. km.

Length of Roads for laying fiber is 2152Km

Number of Households (including Duplexes, townhomes, single family, condos etc.):
14010

7.4 Implementation of GPON based FTTH Network

Now we will discuss the step by step procedure to deploy GPON based FTTH network. The design will take the bottom up approach meaning the design will start from end users until reaching central office moving backward.

FTTH project required both civil and technical expertise. A pre-defined plan is very crucial for the deployment as an error at certain may lead to a lot of changes in other stages consuming a lot of time and money.

Design of the FTTH network is challenging one hence different aspect has to be taken into account before we even start planning the infrastructure like scalability, size, cost etc. There is not a standard model for the setup of the infrastructure as it depends upon topology, the density of users etc.

In this project, we have selected the city of Leduc as our site for the deployment. The city of Leduc has 14010 households and hence the project will concentrate upon the deployment on these households. As explained earlier the project will take bottom to up approach. Hence following is the structural plan for the deployment –

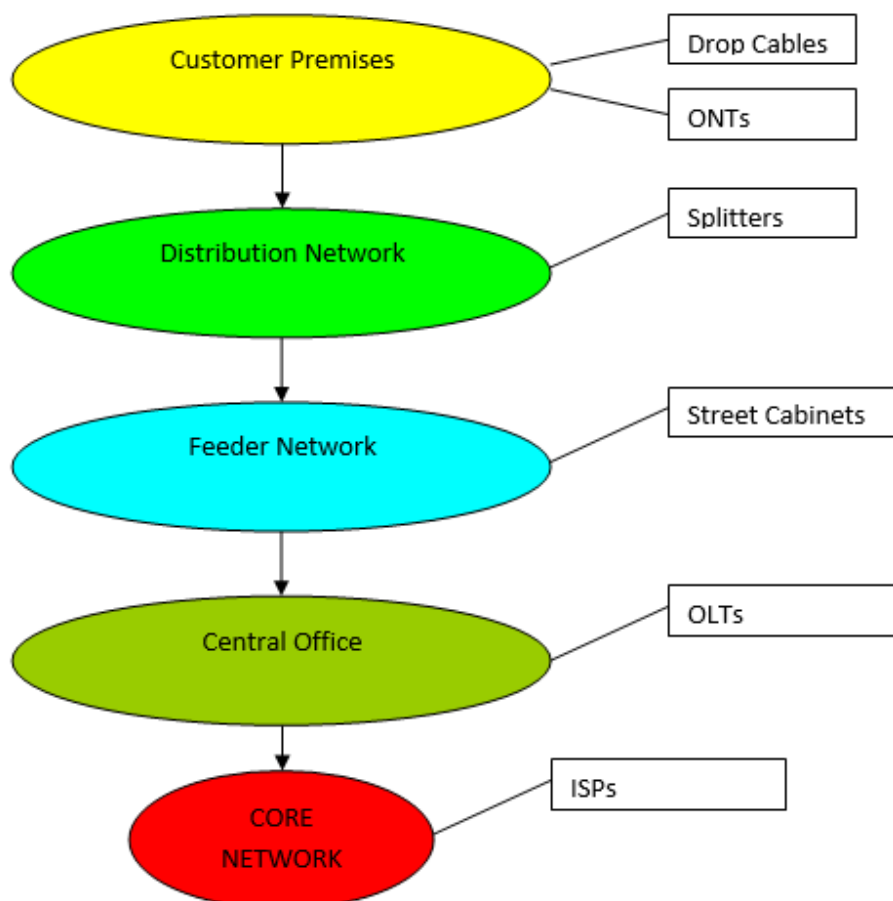

7.4.1 Technical Aspect

Customer Premises – The drop cables are used to connect splitters to the premises. Drop cables are used because of their flexibility, less diameter, ease of access etc. Cost of drop cables ranges anywhere from \$100 to \$200 for every 1000 feet.

Distribution Network – Using distribution network the splitters, that are normally mounted on the pole on the entrance of the neighborhood are connected with feeder network splitters. Also known as a fiber access terminal. Each FAT for our project serves 16 homes hence 1:16 distribution. Cost of the splitter ranges from \$50 to \$100 per splitter.

Feeder Network – It extends from Central Office to the distribution points usually are Street Cabinets. These cabinets also have splitters and these splitters for our project purpose also serve 16 distribution.

Central Office – The function of the central office is to host the OLT and at times some components of the core network. Cost of OLT ranges anywhere from \$2500 to \$5000.

Core Network – It comprises of the ISP equipment.

7.4.2 Civil Aspect

All the different stages of the network are connected using civil expertise. The cables have to be laid underground, using poles, etc. For long-lasting and high-performance solutions we need to go underground with a pipe system that will protect the fiber. Protective pipe system using thickly walled ducts are used for agility and these micro ducts are used to be made into a bundle of several ducts. Following are some of the techniques used these days for the laying of fiber depending upon the circumstances:

- Digging the trench with mini excavators.
- Vibrator Plowing.
- Trenching through open landscapes.
- Micro trenching.
- Horizontal Directional Drilling
- Relining

The cost of deploying fiber ranges anywhere between \$3 to \$6 per foot

Reference: <https://www.itscosts.its.dot.gov>

Approximate cost of Deployment of FTTH in City of Leduc is as follows:

No of Splitters required Distributor Network: $14010/16 = 876$ splitters.

No of Splitters required Feeder Network or the street cabinets or we can also call them convergence point: $876/16 = 55$ splitters

No of OLTs required: 2 as an area to be covered is approx. 40 sq. Km and one OLT can cover up to 20 Sq.km

Length around where cable to be laid : $2152\text{Km} \times 3280.04 = 7058646.08\text{feet}$.

Approximate cost is as follows:

Description	Quantity	Cost/unit	Total
Splitter	931	\$100	\$93100
OLT	2	\$5000	\$10000
Length of Fibber	7058646.08 feet	\$6	\$423,518,76.48

Total Approximate Cost of Deployment \$424,549,76.48

7.5 R-CORD DEPLOYMENT

From network deployment perspective R-CORD spans Central Office, access network and home equipment. RCORD virtualizes Network Equipment, OLTs, Customer Premises Equipment, and Broadband Network Gateway. RCORD strategy is to reformulate NEs as software running on commodity servers, white box switches, and commodity silicon-based I/O blades.

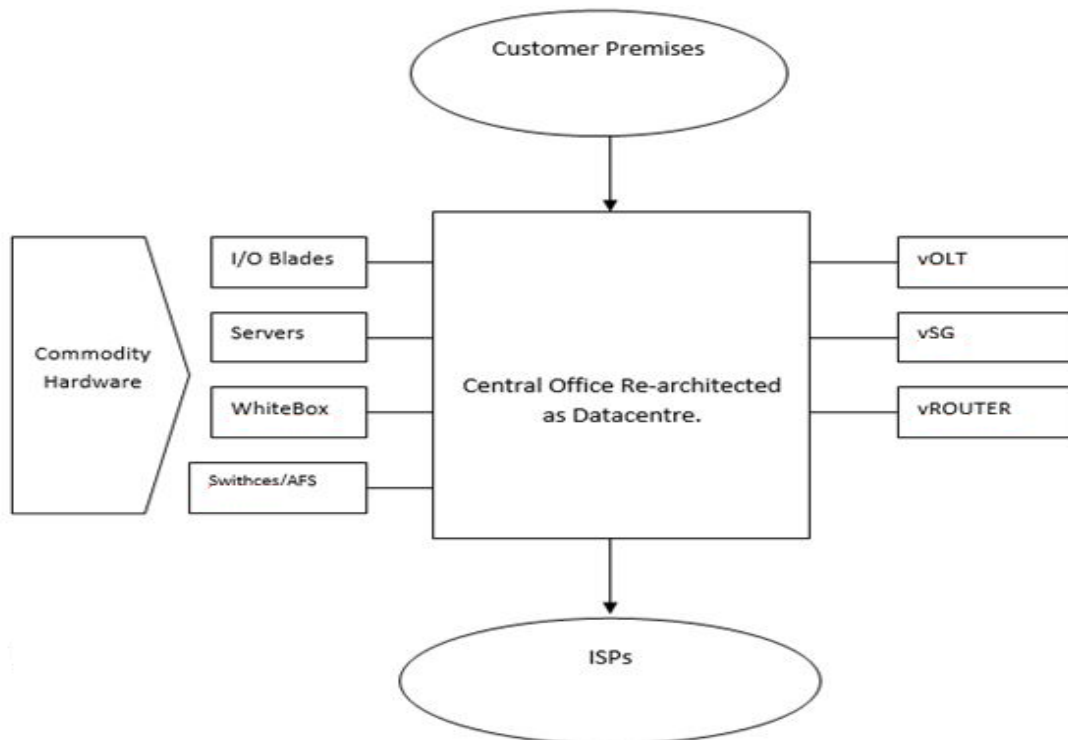

The important feature of CORD, as opposed to the traditional datacentre, is that CORD focuses on management of massive amounts of physical fibre connections in addition to bandwidth traffic.

Within CORD architecture, OLT disaggregation takes care of the physical OLT NEs to the R-CORD architecture. The fibre connects the disaggregated OLT I/O blades. R-CORD functions on servers and white box switches using disaggregated packaging.

R-CORD access rack consists of four hardware elements:

- I/O Blades
- AFS – fibre management
- Switches
- Servers – VM instantiations

Cost of deployment of R-CORD is way lower as compared to GPON as the NEs are virtualized and R-CORD uses existing infrastructure. One R-CORD installation can take care of whole LEDUC city for their smooth running and maintaining of internet services.

7.6 Comparison between R-CORD and GPON based FTTH network

DESCRIPTION	COMPARISON
-------------	------------

COST	<p>As worked out above the cost of deployment of GPON based FTTH network is based on the hardware and support systems. The maintenance cost automatically increases as the hardware has to be managed daily. The repair and troubleshooting also is a big part leading to an increase in the cost. We need two Central Offices if we use GPON based FTTH network however only one is required in case of R-CORD.</p>
------	--

Today's architectures are inflexible, fixed and are separate for each access topologies e.g. GPON, Ethernet, etc. Each of these architectures require well trained specialists and unique methods and procedures leading to redundant and extra expenses and makes adding new services close to impossible.

We need two Central Offices if we use GPON based FTTH network however only one is required in case of R-CORD.

However, the CORD is based on Data Center with the agility of the Cloud as explained earlier whereby using Leaf-Spine architecture switch fabric, white box servers and I/O shelves makes it very easy to add any new service and also makes it available to a larger area and hence making CORD lesser in expense.

OPERATIONAL

The access network is by definition a network for localities and regions differ extraordinarily crosswise over locales and as a rule on an area by-neighborhood basis. Along these networks, it's basic for a local network or broadband system administrator to have numerous access network architectures. Most utilized their phone twisted pair copper cables that associated for all intents and purposes each structure in their working territory to offer some type of DSL administration. Remember that every DSL network has its unique administration frameworks, Method and Procedures (M&P) etc.

With the CORD design to help DSL-based administrations, one just needs to build up another I/O rack. Whatever remains of the framework is the equivalent. Presently, both GPON framework and DSL/FTTx foundations "look" like a solitary framework from an administration viewpoint. You can offer a similar administration bundles. After the packets from the home leave the I/O rack, "packets" can use the unified VNF's and backend foundations.

Hence making the CORD infrastructure much flexible and easier to manage operational wise.

Packets from the home leave the I/O rack, "packets" can use the unified VNF's and backend foundations.

Hence making the CORD infrastructure much flexible and easier to manage operational wise.

TECHNICAL

R-CORD based network takes into account both the infrastructure and functionality however for GPON based FTTH network both the components are separate and separately managed. Hence as the project sheds a lot of light on the technical supremacy of RCORD over GPON.

The CORD project is based on the vision of future CO and can support several services, i.e. residential broadband, enterprise services and mobile services. CORD uses "disaggregation" and it distributes functionality throughout CORD architecture. It also takes care of the mapping of physical OLT to the CORD platform using leaf spine switch structure.

However, if we talk about the GPON based architecture there has to be separate infrastructure for each service and hence all the technical aspects have to be planned separately for it which not the case in CORD.

CONCLUSION

For the service providers, the demand for the bandwidth is growing exponentially, on the other hand, the revenue is growing at a far slower speed. So, the providers need to invest for something innovative to be in the competition, but the problem is that the per bit cost spent is not increasing as the traffic flow, that is increasing madly. The solution to this problem can be solved by virtualization. So, the best solution is RECORD that had been discussed in my report.

RECORD's objective is to alter the traditional specific purpose hardware with flexible and low cost off the shelf components, so it is better than traditional GPON as it is a new and innovative concept. The advantages of RECORD that is making it better than GPON is it is transparent and reduced difficulties being faced by traditional infrastructure. Moreover, there is no need for any dedicated hardware that reduces cost. It can easily cope up with the increased demands as it is more flexible and scalable. RECORD leverages SDN, NFV, and cloud. So, the capital and operating expenses are less that is CAPE and OPEX respectively. With the virtualization of conventional devices, network operators do not have to put resources into the establishment and support of physical hardware to run a chain of system associated devices. Rather, they can buy reasonable nodes to run virtual machines that have higher capacities. These system capacities can be introduced on VMs in weeks. Establishment on restrictive hardware, might even, takes months. It also gives faster time to service. If an application running on a VM requires more transfer speed, for instance, an administrator can dump some portion of the outstanding task at hand onto the shoulders of an alternate VM running on a similar server. Resources are shared all through the network as opposed to being bound to a restricted data center. It also provides with lots of ways for the deployment of VNFs to the third-party providers. These suppliers can bundle their services in the state of a VM or SDN control program. Even though it is still developing the architecture will continually grow and be used rapidly for commercial deployments and will add innovation to business models.

ABBREVIATIONS AND ACRONYMS

TERMS	DESCRIPTIONS
FTTH	Fiber to home
FTTC	Fiber to curb
FTTB	Fiber to building
GPON	Gigabyte passive optical networks
RCORD	Residential Central Office Re-architected as Datacentre
POP	Point Of Presence
DSL	Digital Subscriber Line
DSLAM	Digital Subscriber Line Access Multiplexer
VDSL2	Very-High-Bit-Rate Digital Subscriber Line 2
P2P	Pont to Point
HD	High Definition
KM	Kilometer
P2M	Point To Multipoint
ONT	Optical Network Terminal
EMI	Electromagnetic Interference
SDN	Software Defined Network
NFV	Network Function Virtualization
WAN	Wide Area Network
WTDC	World Telecommunication Department Conference
PON	Passive Optical Network
ITU-T	Telecommunication Standardized Sector
FSAN	Full-Service Access Network

POTS	Plain Old Telephone Service
VoIP	Voice over Internet Protocol
TDM	Time Division Multiplexing
APON	ATM Passive Optical Network
BPON	Broadband Passive Optical Network
NG-PON	Next Generation Passive Optical Network
ONU	Optical Network Unit
MPCP	Multi-Point Control Protocol
LLID	Logical Link Identification
RS	Reconciliation sub layer
PCS	Physical coding sub layer
PMA	Physical media Attachment
PMD	Physical media Dependent
FEC	Forward error correction
SNR	Signal To Noise Ratio
NMS	Network Management System
WDM	Wavelength Division Multiplexing
OFDM	Orthogonal Frequency Division Multiplexing
ADSL	Asymmetric digital subscriber line
DVB-T	Digital Video Broadcasting-Terrestrial
WLAN	Wireless LAN
3GPP LTE	3rd Generation Partnership Project Long Term Evolution
WiMAX	Worldwide Interoperability for Microwave Access
OLT	Optical Line Terminal
ODN	Optical Distribution Network

GFP	Generic Framing Procedure
PLC	Planar Lightwave Circuit
ISP	Internet Service Provider
PSTN	Public Switched Telephone Network
FAT	File Allocation Table
FCA	Fiber cable attenuation
CORD	Central Office Re-architected as Datacentre.
CO	Central Office
VNF	virtual network function
NE	Network Element
DC	Data center
EPC	Evolved Packet Core
DU	Digital unit
RRU	Remote radio unit
Vbbu	Virtual baseband unit
CPRI	Common Public Radio Interface
MNO	Mobile network operator
FPM	Forwarding plane manager
CDN	Content distribution network
CVLAN	Customer VLAN
SVLAN	Subscriber VLAN
OMCI	ONU management and control interface
OAM	Operations, administration and management
ONOS	Open Network Operating system

REFERENCES

https://fenix.tecnico.ulisboa.pt/downloadFile/3779576267480/12_GPON_%252520Informati%252520Technology%252520Interfaces,%2525202007.%252520ITI%2525202007.%25252029th%252520International%252520Conference%252520on.pdf

9781461439387-c1.pdf

https://www.ftthcouncil.eu/documents/Publications/FTTH_Business_Guide_V5.pdf

https://www.ftthcouncil.eu/documents/Publications/DandO_White_Paper_2_2014.pdf

https://www.opennetworking.org/wp-content/uploads/2019/01/Day1_Session8_CORD-Build.pdf

https://www.opennetworking.org/wp-content/uploads/2019/01/R-CORD_VOLTHA_Intro-CORDBuild-Day1.pdf

https://www.youtube.com/watch?v=d5Axn6Clb5U&list=PLCnPGaNt7C5c-cHipf_kVt0Cv26pnRAHn

What's Software-Defined Networking (SDN)? (n.d.). Retrieved March 13, 2019, from <https://www.sdxcentral.com/networking/sdn/definitions/what-the-definition-of-software-defined-networking-sdn/>

CommScope. (n.d.).

https://webcache.googleusercontent.com/search?q=cache:ZSNWoVmQH-UJ:https://www.commscope.com/Docs/How_CORD_will_impact_your_central_office_WP-112415-EN.pdf&cd=11&hl=en&ct=clnk&gl=ca. Retrieved February 10, 2019, from https://webcache.googleusercontent.com/search?q=cache:ZSNWoVmQH-UJ:https://www.commscope.com/Docs/How_CORD_will_impact_your_central_office_WP-112415-EN.pdf&cd=11&hl=en&ct=clnk&gl=ca

CORD Build 2017 Collateral. (n.d.). Retrieved September 10, 2018, from <https://www.opennetworking.org/cord-build-2017-collateral/>

How GPON Works. (n.d.). Retrieved October 10, 2018, from <http://www.gpon.com/how-gpon-works>

Fs.com. (n.d.). Components and Architecture of GPON FTTH Access Network | FS - Fiberstore. Retrieved December 2, 2018, from <https://www.fs.com/components-and-architecture-of-gpon-ftth-access-network-aid-481.html>

Exfo. (n.d.). Network test, monitoring and analytics experts. Retrieved December 2, 2018, from <http://www.exfo.com/>

Tutorialspoint.com. (n.d.). FTTH GPON. Retrieved November 15, 2018, from https://www.tutorialspoint.com/ftth/ftth_gpon.htm

GPON Special Topic 02. (n.d.). Retrieved December 10, 2018, from <https://support.huawei.com/enterprise/en/doc/EDOC1000078313?section=j009&topicName=gpon-protocol-stacks>

GPON Service Multiplexing. (2016, May 04). Retrieved December 29, 2018, from <https://jornathunderlinkcom.wordpress.com/2016/05/04/gpon-service-multiplexing/>

Tutorialspoint.com. (n.d.). FTTH GPON. Retrieved November 15, 2018, from https://www.tutorialspoint.com/ftth/ftth_gpon.htm

CORD, O. (2017, December 01). CORD Technical Overview. Retrieved January 3, 2019, from <https://www.youtube.com/watch?v=eEjb9zXbuEQ&list=PLCnPGaNt7C5f5XJTM8hhxyaxlskYZWRDm&index=7> Fs.com. (n.d.). Overview of GPON Technology | FS - Fiberstore. Retrieved November 11, 2018, from <https://www.fs.com/overview-of-gpon-technology-aid-500.html>

CORD: An Introduction to the Platform - ONF Bootcamp, May 23, 2017. (2019, March 13). Retrieved October 16, 2018, from <https://vimeo.com/218989549>

Residential CORD - CORD. (n.d.). Retrieved October 15, 2018, from [https://wiki.opencord.org/display/CORD/Residential CORD](https://wiki.opencord.org/display/CORD/Residential+CORD)

Radcliffe, D. (2014, May 09). Who's the world's fibre broadband leader? Prepare to be surprised. Retrieved October 25, 2018, from <https://www.zdnet.com/article/whos-the-worlds-fibre-broadband-leader-prepare-to-be-surprised/>

CORD Build 2017. (n.d.). Retrieved January 5, 2019, from <https://cordbuild2017.sched.com/event/CFGh/introduction-to-r-cord-and-voltha>

CORD (Central Office Re-architected as a Datacenter): The killer app for SDN & NFV. (n.d.). Retrieved December 5, 2018, from <https://opencord.org/collateral/>

ONF Connect. (n.d.). Retrieved December 6, 2019, from <https://www.opennetworking.org/onf-connect/>

Resources - ONF Connect 2018. (n.d.). Retrieved January 7, 2019, from <https://www.opennetworking.org/onf-connect-2018-collateral/>

<https://www.opennetworking.org/wp-content/uploads/2018/12/SEBA-Overview.pdf>

SEBA: SDN ENABLED BROADBAND ACCESS – AN OVERVIEW. (2019, March 13). Retrieved March 14, 2019, from <https://vimeo.com/312130923>

Truong_RFD Follow. (2012, April 03). 35992488 gpon-fundamentals-20070606-a. Retrieved November 10, 2018, from https://www.slideshare.net/Truong_RFD/35992488-gponfundamentals20070606a

exfo_book_fttx-pon-technology-testing_en.pdf

exfo_fttx_pon_reference_guide_en.pdf

OFC_2018_BBF_NG-PON2_workshop.pdf

GPON Security. (n.d.). Retrieved October 10, 2018, from <http://www.gpon.com/gpon-security>

Home. (n.d.). Retrieved December 11, 2018, from <https://www.broadband-forum.org/>

GPON Special Topic 02. (n.d.). Retrieved October 11, 2018, from <https://support.huawei.com/enterprise/en/doc/EDOC1000078313?section=j00b&topicName=omci>

ABC of PON: Understanding OLT, ONU, ONT and ODN. (2018, October 15). Retrieved December 14, 2018, from <https://community.fs.com/blog/abc-of-pon-understanding-olt-onu-ont-and-odn.html>

NFV and SDN: What's the Difference? (n.d.). Retrieved December 3, 2018, from <https://www.sdxcentral.com/articles/contributed/nfv-and-sdn-whats-the-difference/2013/03/>

Kanika, Senadheera, S., Singh, M., Ghutukade, S., Satchmo, & Abeywardhana, J. (n.d.). Home. Retrieved January 08, 2019, from <http://sdntutorials.com/difference-between-control-plane-and-data-plane/>

Arora, H. (n.d.). Software Defined Networking (SDN) explained for beginners. Retrieved December 26, 2018, from <https://www.howtoforge.com/tutorial/software-defined-networking-sdn-explained-for-beginners/>

Open Network Operating System. (n.d.). Retrieved December 22, 2018, from <https://onosproject.org/>

Hughes, P. (2018, October 29). How cable MSOs can have a competitive edge with SDN. Retrieved December 12, 2018, from <https://www.broadbandtechreport.com/articles/2018/10/how-cable-msos-can-have-a-competitive-edge-with-sdn.htm>

Kinney, S. (2017, July 07). What is CORD? Retrieved December 28, 2018, from <https://www.rcrwireless.com/20170706/wireless/what-is-cord-tag27>

M-CORD Project Overview - CORD. (n.d.). Retrieved December 12, 2018, from [https://wiki.opencord.org/display/CORD/M-CORD Project Overview](https://wiki.opencord.org/display/CORD/M-CORD+Project+Overview)

Virtual Subscriber Gateway (vSG) - CORD. (n.d.). Retrieved December 10, 2018, from <https://wiki.opencord.org/pages/viewpage.action?pageId=1278090>

https://www.youtube.com/watch?v=d5Axn6Clb5U&list=PLCnPGaNt7C5c-cHipf_kVt0Cv26pnRAHn

<https://www.google.com/maps/d/u/0/viewer?hl=en&ie=UTF8&msa=0&ll=53.25409700000001%2C-113.53447399999999&spn=0.019076%2C0.055747&z=15&iwloc=0004799a84d65eb5e4afd&mid=1Qh2hOfORLtz1UX0vZ7JkMIiyyjU>

Retrieved from

<https://lh5.googleusercontent.com/8GiYkijdimBnv6yywuXnz4oU0VGRk2Xp2Vbl-SSqCovkqPDg3zATWNWctnq4IyJXCpAk9RTKobndclML4PgSs6K>

<https://www.google.com/maps/d/u/0/viewer?hl=en&ie=UTF8&msa=0&ll=53.25409700000001%2C-113.53447399999999&spn=0.019076%2C0.055747&z=15&iwloc=0004799a84d65eb5e4afd&mid=1Qh2hOfORLtz1UX0vZ7JkMIiyyjU>

