

Critical Care Considerations in the Management of Acute Liver Failure

by

Andrew John MacDonald

A thesis submitted in partial fulfillment of the requirements for the degree of

Master of Science

in

Clinical Epidemiology

School of Public Health  
University of Alberta

© Andrew John MacDonald, 2020

## ABSTRACT

Acute Liver Failure (ALF) is a rare syndrome involving rapid deterioration of liver function in patients without pre-existing liver disease or cirrhosis. Within North America, acetaminophen (APAP)-induced ALF represents the most common etiology. Regardless of etiology, ALF patients are critically ill and may develop multi-organ failure, intracranial hypertension (ICH), or cerebral edema (CE). Improving transplant-free survival (TFS) remains the goal of critical care management. Extracorporeal liver support systems, specifically the molecular adsorbent recirculating system (MARS), remove water-soluble and albumin-bound toxins and aim to create an environment for native organ recovery or, in those failing medical therapy, bridging to liver transplantation (LT). The role of MARS in TFS remains in question.

This thesis aimed to:

1. Evaluate changes in clinical interventions, psychosocial profile and important clinical outcomes over a 21-year period in APAP-ALF using data from the *ALF Study Group* (ALFSG) registry.
2. Evaluate the association MARS, compared to standard medical therapy (SMT), with TFS in all-etiology ALF using data from the ALFSG registry.

First, a retrospective review of the prospective, multicentre ALFSG cohort study of all APAP-ALF patients enrolled over 1998-2018 was completed. Primary outcomes evaluated were 21-day TFS and neurological complications. Covariates evaluated included enrollment cohort (early: 1998-2007; recent: 2008-2018), overdose

intentionality, psychiatric comorbidity and the use of organ support including continuous renal replacement therapy (CRRT).

Second, a retrospective review of all ALF patients treated with MARS between January 2009 and 2019 at three North American transplant centres was completed. Propensity scores (PS) were used to match SMT-treated patients using data from the US ALFSG registry. Primary outcome was 21-day TFS and was evaluated using multivariable conditional logistic regression, adjusting for imbalanced covariates following matching. Secondary outcomes included change in clinical and biochemical parameters post-treatment in MARS patients.

Of 1190 APAP-ALF patients (early: n=582; recent: n=608); recent cohort patients had significantly improved TFS (recent: 69.8% vs. early: 61.7%; p=0.005). Recent cohort patients were more likely to receive CRRT (22.2% vs. 7.6%; p<0.001), less likely to develop ICH (29.9% vs. 51.5%; p<0.001), and less likely to die by day 21 due to CE (4.5% vs. 11.6%; p<0.001). Grouped by TFS status (non-TFS: n=365 (died/transplanted) vs. TFS: n=704), there were no differences in pre-existing psychiatric comorbidity (51.5% vs. 55.0%; p=0.28) or overdose intention (intentional: 39.7% vs. 41.6%; p=0.58). On multivariable logistic regression adjusting for vasopressor support, development of grade 3/4 hepatic encephalopathy (HE), King's College Criteria (KCC), and model for end-stage liver disease score, the use of CRRT (OR 1.62; p=0.023) was associated with significantly increased TFS (c-statistic 0.86). In a second model adjusting for the same covariates, recent enrollment was significantly associated with TFS (OR 1.42; p=0.034; c-statistic 0.86).

Of 104 ALF patients that received MARS, 104 patients were PS-matched (4:1) to 416 SMT patients. Significant improvements in clinical and biochemical parameters were observed following MARS therapy, particularly in APAP-ALF patients. Using multivariable conditional logistic regression adjusting for ALF etiology, age, vasopressor support, international normalized ratio, and meeting KCC, MARS therapy was not associated with increased TFS (*Main Model*; MARS OR 1.60;  $p=0.093$ ). Following addition of PS (MARS OR 1.90;  $p=0.030$ ), and PS, mechanical ventilation, and development of grade 3/4 HE (MARS OR 1.91;  $p=0.029$ ) to the *Main Model*, and in a model adjusting for ALF etiology and PS (MARS OR 1.86;  $p=0.033$ ), MARS was associated with significantly increased 21-day TFS in sensitivity analyses.

In conclusion, TFS in APAP-ALF has improved in recent years and rates of ICH/CE have declined, possibly related to increased CRRT use. Following MARS therapy, biochemical variables trended towards normalization and, in APAP-ALF, hemodynamic status improved. Treatment with MARS was associated with a trend towards increased TFS over SMT in ALF.

## PREFACE

This thesis is an original work by Andrew J. MacDonald. The research project, of which this thesis is a part, received research ethics approval from the University of Alberta Research Ethics Office's Health Research Ethics Board (HREB), Project Name "ALFSG Acute Liver Failure Study Group", No. Pro00041365, approved November 28, 2013.

Some of the research conducted for this thesis forms part of an international research collaboration through the *Acute Liver Failure Study Group*, led by Dr. William M. Lee at the University of Texas Southwestern Medical Center, with Dr. Constantine J. Karvellas serving as lead collaborator at the University of Alberta and principal investigator of this thesis research.

The identification and design of this research was done in collaboration with Dr. Juan G. Abraldes, Dr. David L. Bigam, Dr. Constantine J. Karvellas, and the *Acute Liver Failure Study Group* (members and institutions participating in the *Acute Liver Failure Study Group* during the study period are listed under *Acknowledgements*).

Chapter 2 patient data and Chapter 3 standard medical therapy control group patient data were provided by the *Acute Liver Failure Study Group*. Chapter 3 molecular adsorbent recirculating system patient data was collected by Andrew J. MacDonald (University of Alberta patients), Dr. Jody C. Olson and Ms. Brianne M. Shropshire (University of Kansas Medical Center patients), and Dr. Ram M. Subramanian and Dr. Ravi S. Vora (Emory

University Hospital patients). Chapter 2 and Chapter 3 statistical analyses were completed by Andrew J. MacDonald and Dr. Jaime L. Speiser. Chapter 3 propensity score matching was performed by Dr. Valerie L. Durkalski-Mauldin and Ms. Jingwen Zhang.

*Chapter 2 of this has been submitted as:*

MacDonald AJ, Speiser JL, Ganger DR, Nilles KM, Orandi BJ, Larson AM, Lee WM, Karvellas CJ. Clinical and neurological outcomes in acetaminophen-induced acute liver failure: a twenty-one year multicenter cohort study. *Submitted to Clinical Gastroenterology and Hepatology (June 8, 2020). Under Review.*

AJM was responsible for study design, statistical analysis, interpretation of data, and preparation of the manuscript. JLS assisted with statistical analysis, interpretation of data, and critically revised the final manuscript. DRG, KMN, BJO, AML, and WML critically revised the final manuscript. CJK served as the supervisory author, and was responsible for study design, interpretation of data, and critically revising the final manuscript.

## ACKNOWLEDGEMENTS

I wish to acknowledge the support of the Clinician Investigator Program, the Division of General Surgery, the Department of Critical Care Medicine, and Alberta Health Services for their academic and financial support in completing this thesis.

I would like to express my sincere gratitude to all members of my supervisory committee for their endless support:

*Dr. Constantine J. Karvellas:* as my primary supervisor, thank you for your expertise, research mentorship, and unwavering encouragement.

*Dr. David L. Bigam:* as my co-supervisor, thank you for your immeasurable clinical and career mentorship, leadership, and research guidance.

*Dr. Juan G. Abraldes:* thank you for your vast hepatology and statistical knowledge, thoughtful commentary, and clear research direction.

Finally, I would like to thank Dr. William M. Lee and the members of the *Acute Liver Failure Study Group* for their instrumental roles in allowing this research to be completed. Participating institutions and members (1998-2018) include: W.M. Lee, M.D. (Principal Investigator); Anne M. Larson, M.D., Iris Liou, M.D., University of Washington, Seattle, WA; Oren Fix, M.D., Swedish Medical Center, Seattle, WA; Michael Schilsky, M.D., Yale University, New Haven, CT; Timothy McCashland, M.D., University of Nebraska, Omaha, NE; J. Eileen Hay, M.B.B.S., Mayo Clinic, Rochester, MN; Natalie Murray, M.D., Baylor

University Medical Center, Dallas, TX; A. Obaid S. Shaikh, M.D., University of Pittsburgh, Pittsburgh, PA; Andres Blei, M.D., Northwestern University, Chicago, IL (deceased), Daniel Ganger, M.D., Northwestern University, Chicago, IL; Atif Zaman, M.D., University of Oregon, Portland, OR; Steven H.B. Han, M.D., University of California, Los Angeles, CA; Robert Fontana, M.D., University of Michigan, Ann Arbor, MI; Brendan McGuire, M.D., University of Alabama, Birmingham, AL; Raymond T. Chung, M.D., Massachusetts General Hospital, Boston, MA; Alastair Smith, M.B., Ch.B., Duke University Medical Center, Durham, NC; Robert Brown, M.D., Cornell/Columbia University, New York, NY; Jeffrey Crippin, M.D., Washington University, St Louis, MO; Edwin Harrison, Mayo Clinic, Scottsdale, AZ; Adrian Reuben, M.B.B.S., Medical University of South Carolina, Charleston, SC; Santiago Munoz, M.D., Albert Einstein Medical Center, Philadelphia, PA; Rajender Reddy, M.D., University of Pennsylvania, Philadelphia, PA; R. Todd Stravitz, M.D., Virginia Commonwealth University, Richmond, VA; Lorenzo Rossaro, M.D., University of California Davis, Sacramento, CA; Raj Satyanarayana, M.D., Mayo Clinic, Jacksonville, FL; and Tarek Hassanein, M.D., University of California, San Diego, CA; Constantine J. Karvellas MD, University of Alberta, Edmonton, AB; Jodi Olson MD, University of Kansas, Kansas City, KA; Ram Subramanian MD, Emory, Atlanta, GA; James Hanje MD, Ohio State University, Columbus, OH; Bilal Hameed MD, University of California San Francisco, CA. The University of Texas Southwestern Administrative Group included Grace Samuel, Ezmina Lalani, Carla Pezzia, and Corron Sanders, Ph.D., Nahid Attar, Linda S. Hynan, Ph.D., and the Medical University of South Carolina Data Coordination Unit included Valerie Durkalski, Ph.D., Wenle Zhao, Ph.D., Jaime Speiser, Ph.D., Catherine Dillon, Holly Battenhouse, and Michelle Gottfried.



## TABLE OF CONTENTS

<b>CHAPTER 1—INTRODUCTION: A REVIEW OF ACUTE LIVER FAILURE AND EXTRACORPOREAL LIVER SUPPORT IN ACUTE LIVER FAILURE.....</b>	<b>1</b>
1.1 Acute Liver Failure: An Overview .....	2
1.2 Defining Acute Liver Failure .....	3
1.3 Epidemiology.....	5
1.4 Causes of Acute Liver Failure.....	6
1.4.1 Acetaminophen Toxicity.....	6
1.5 Critical Care Management.....	7
1.5.1 Neurologic Management.....	8
1.5.2 Hemodynamic Management.....	10
1.5.3 Renal Management .....	11
1.6 Liver Transplantation.....	12
1.7 Prognosis in Acute Liver Failure.....	12
1.8 Extracorporeal Liver Support.....	14
1.8.1 Overview of Extracorporeal Liver Support in ALF.....	14
1.8.2 Artificial ECLS: Molecular Adsorbent Recirculating System in ALF .....	15
1.8.3 Artificial ECLS: High-Volume Plasmapheresis in ALF .....	17
1.8.4 Bioartificial ECLS: HepatAssist in ALF.....	17
1.8.5 Bioartificial ECLS: Extracorporeal Liver Assist Device in ALF .....	18
1.9 Statement of the Problem and Objectives.....	19
1.10 References.....	24
<b>CHAPTER 2—THE NATURAL HISTORY OF ACETAMINOPHEN-INDUCED ACUTE LIVER FAILURE .....</b>	<b>36</b>
2.1 Introduction .....	37
2.2 Patients and Methods.....	38
2.2.1 Study Design .....	38
2.2.2 Participants.....	39
2.2.3 Operational Definitions .....	39
2.2.4 Clinical Variables and Endpoints .....	40
2.2.5 Statistical Analysis .....	41

2.3 Results .....	42
2.3.1 Baseline APAP-ALF Cohort Parameters .....	42
2.3.2 Univariate Analysis of APAP-ALF Patients: Enrollment Time Cohort .....	42
2.3.3 Univariate Analysis of Admission (Day 1) Parameters: Enrollment Time Cohort .....	43
2.3.4 Univariate Analysis of APAP-ALF Patients: 21-day Transplant-free Survival ...	44
2.3.5 Multivariable Analysis: Associations with TFS .....	44
2.4 Discussion .....	45
2.4.1 Key Results.....	45
2.4.2 Comparison with the Literature .....	46
2.4.3 Strengths and Limitations .....	49
2.5 Conclusions.....	50
2.6 References.....	64
<b>CHAPTER 3—THE ROLE OF THE MOLECULAR ADSORBENT RECIRCULATING SYSTEM IN ACUTE LIVER FAILURE.....</b>	<b>69</b>
3.1 Introduction .....	70
3.2 Patients and Methods.....	71
3.2.1 Study Design .....	71
3.2.2 Participants.....	72
3.2.3 Operational Definitions .....	72
3.2.4 Clinical Variables and Endpoints .....	73
3.2.5 Statistical Analysis .....	74
3.3 Results .....	75
3.3.1 Baseline Patient Parameters .....	75
3.3.2 MARS Protocols .....	76
3.3.3 Comparisons of Pre-MARS and Post-MARS Parameters .....	77
3.3.4 Multivariable Analyses: Associations with TFS.....	78
3.4 Discussion.....	79
3.4.1 Key Results.....	79
3.4.2 Comparison with the Literature .....	79
3.4.3 Strengths and Limitations .....	81
3.5 Conclusion .....	83
3.6 References.....	98
<b>CHAPTER 4—SUMMARY.....</b>	<b>102</b>

4.1 *Summary of Findings* ..... 103

4.2 *Implications and Future Directions* ..... 104

4.3 *References*..... 106

**REFERENCES**..... **107**

## LIST OF TABLES

<b>Table 1.1.</b> Summary of landmark trials on the use of artificial and bioartificial extracorporeal liver support systems in acute liver failure. .....	21
<b>Table 2.1.</b> Demographic, clinical, and outcome parameters in APAP-ALF patient cohort. .....	51
<b>Table 2.2.</b> Patient parameters stratified by time cohort (1998-2007 vs. 2008-2018). .....	53
<b>Table 2.3.</b> Biochemical and organ support parameters at admission, stratified by time cohort (1998-2007 vs. 2008-2018). .....	55
<b>Table 2.4.</b> Patient parameters stratified by spontaneous survival at day 21 (deceased/transplanted vs. transplant-free survivors). .....	57
<b>Table 2.5.</b> Biochemical and organ support parameters at admission, stratified by spontaneous survival at day 21 (died/transplanted vs. transplant-free survivors). .....	59
<b>Table 2.6.</b> Predictors of 21-day transplant-free survival in APAP-ALF patients. .....	61
<b>Table 3.1.</b> Matched Baseline (pre-MARS/admission) characteristics of MARS and SMT treated patients after propensity score matching. .....	84
<b>Table 3.2.</b> Additional non-matched baseline (pre-MARS/admission) characteristics of MARS and SMT treated patients. .....	85
<b>Table 3.3.</b> Summary of MARS therapy parameters (n=104). .....	86
<b>Table 3.4.</b> Comparative analysis of clinical and biochemical parameters following MARS therapy, grouped by ALF etiology. .....	87
<b>Table 3.5.</b> Predictors of 21-day transplant-free survival in a propensity score-matched cohort: main model (MARS: n=104; SMT: n=416).	

.....	89
<b>Table 3.6.</b> Predictors of 21-day transplant-free survival: sensitivity analysis model one (MARS: n=104; SMT: n=416).	90
.....	90
<b>Table 3.7.</b> Predictors of 21-day transplant-free survival: sensitivity analysis model two (MARS: n=104; SMT: n=416).	91
.....	91
<b>Table 3.8.</b> Predictors of 21-day transplant-free survival: sensitivity analysis model three (MARS: n=104; SMT: n=416).	92
.....	92
<b>Table 3.9.</b> Predictors of 21-day transplant-free survival: sensitivity analysis model four (MARS: n=104; SMT: n=416).	93
.....	93
<b>Table 3.10.</b> Predictors of 21-day transplant-free survival: sensitivity analysis model five (MARS: n=104; SMT: n=416).	94
.....	94
<b>Table 3.11.</b> Outcomes at 21 days following treatment with MARS or SMT.	95
.....	95

## LIST OF FIGURES

<b>Figure 1.1.</b> Schematic of the molecular adsorbent recirculating system device setup. .....	23
<b>Figure 2.1.</b> Adjusted associations with 21-day transplant-free survival in 1190 APAP-ALF patients. (A) Model 1 and (B) Model 2. .....	63
<b>Figure 3.1.</b> Patient selection flow diagram. .....	96
<b>Figure 3.2.</b> Adjusted associations with 21-day transplant-free survival in 520 propensity-score matched ALF patients: main model. .....	97

## ABBREVIATIONS

AKI – acute kidney injury  
ALF – acute liver failure  
ALFSG-PI – Acute Liver Failure Study Group prognostic index  
ALT – alanine aminotransferase  
APAP – acetaminophen  
(a)OR – (adjusted) odds ratio  
AST – aspartate aminotransferase  
AUROC – area under receiver operator curve  
CE – cerebral edema  
CI – confidence interval  
(C)RRT – (continuous) renal replacement therapy  
ECLS – extracorporeal liver support  
ELAD – extracorporeal liver assist device  
GCS – Glasgow coma scale  
GSH – glutathione  
HE – hepatic encephalopathy  
HD – hemodialysis  
HF – hemofiltration  
HVP – high-volume plasmapheresis or high-volume plasma exchange  
ICH – intracranial hypertension  
ICP – intracranial pressure  
ICU – intensive care unit  
(I)HD – (intermittent) hemodialysis  
INR – international normalized ratio  
IQR – interquartile range  
KCC – King’s College criteria  
LT – liver transplant(ion)  
MAP – mean arterial pressure  
MARS – molecular adsorbent recirculating system  
MELD – model for end-stage liver disease  
MSOF – multisystem organ failure  
NAC – *N*-acetylcysteine  
NAPQI – *N*-acetyl-*p*-benzoquinone imine  
PS – propensity score  
RR – relative risk  
SMD – standardized mean difference  
SMT – standard medical therapy  
TFS – transplant-free survival  
UK – United Kingdom  
(US) ALFSG – (United States) Acute Liver Failure Study Group

**CHAPTER 1—Introduction: A Review of Acute Liver Failure and Extracorporeal  
Liver Support in Acute Liver Failure**



## **1.1 Acute Liver Failure: An Overview**

Acute liver failure (ALF) is a rare syndrome involving rapid deterioration of liver function in the absence of pre-existing liver disease or cirrhosis.<sup>1</sup> Defining features include impaired endogenous hepatic function (i.e. jaundice and coagulopathy) and altered level of consciousness (hepatic encephalopathy (HE)) within 26 weeks of an inciting liver injury.<sup>2,3</sup> Common causes of ALF include acetaminophen (APAP) toxicity, drug-induced (non-APAP) liver injury, acute viral hepatitis, autoimmune hepatitis, vascular-related issues (i.e. ischemia, Budd-Chiari Syndrome), and Wilson's disease.<sup>4</sup> Regardless of etiology, ALF patients are often critically ill and may develop multi-system organ failure (MSOF), necessitating intensive care unit (ICU) admission. Development of cerebral edema (CE) is implicated in up to 25% of deaths in ALF.<sup>5,6</sup> Improved outcomes are seen with prompt diagnosis and coordination of a multidisciplinary healthcare team; however, mortality remains approximately 30%.<sup>1</sup> For those failing medical therapy, liver transplantation (LT) may provide a lifesaving alternative, with approximately 20-30% of North American ALF patients receiving LT.<sup>1,7</sup> Despite this, LT is frequently contraindicated secondary to profound critical illness or psychosocial issues.<sup>8</sup> Extracorporeal liver support (ECLS) systems represent a promising area in the medical management of ALF and may supplement hepatic function until spontaneous recovery occurs.<sup>9-11</sup> Knowledge of the epidemiology, clinical course, considerations for LT, and indicators of poor outcome are necessary among critical care providers, hepatologists, and transplant surgeons caring for ALF patients.

## 1.2 Defining Acute Liver Failure

Trey and Davidson introduced the term *fulminant hepatic failure* to describe “a potentially reversible condition, the consequence of severe liver injury, with an onset of encephalopathy within 8 weeks of the appearance of the first symptoms and in the absence of pre-existing liver disease.”<sup>12</sup> The novelty of this term was three-fold: it characterized a common clinical phenotype associated with what is now known as ALF, it differentiated this syndrome from acute decompensation in patients with existing chronic liver disease (i.e. acute-on-chronic liver failure), and additionally noted potential reversibility. This definition was later recognized as overly specific as significant variation may exist in ALF patients.<sup>4</sup>

In 1993, O’Grady et al broadened the classification system of ALF to encompass variations in clinical features and prognoses based on the time interval between onset of liver injury symptoms and development of HE.<sup>13,14</sup> This classification system was based on King’s College Hospital’s experience with 635 ALF patients receiving medical management in the pre-LT era. *Hyperacute* liver failure was defined as the onset of HE within 1 week of jaundice. These patients were noted to carry the highest risk of CE, but the best potential for transplant-free survival (TFS). *Acute* liver failure was defined by a jaundice-to-HE interval of 2-4 weeks, carrying lower risk of CE, but poor prognosis with medical therapy alone. Finally, *subacute* liver failure was defined by a jaundice-to-HE interval of 5-12 weeks. These patients displayed low rates of CE; however, prognosis in those receiving medical therapy alone was poorest.<sup>13,15</sup> In line with this concept, etiology appears to dictate rate of disease progression and the potential for endogenous hepatic

recovery.<sup>16,17</sup> Acetaminophen hepatotoxicity typically follows hyperacute progression, while viral hepatitis, autoimmune hepatitis, and idiosyncratic drug reactions may follow acute or subacute evolution.<sup>4</sup>

Numerous modern definitions of ALF have since been proposed<sup>13,18-20</sup>, with a recent systematic review reporting 41 unique definitions of ALF across 87 studies.<sup>21</sup> Essential to these definitions is the development of HE following the appearance of symptoms of liver injury in patients without pre-existing cirrhosis. That being said, many studies fail to characterize the exact symptoms necessary to define onset of liver injury. Beyond single time-point drug overdoses, the development of jaundice is frequently used; however, specific serum bilirubin thresholds have not been described. The symptom-to-HE interval is most often quantified as within 8 weeks, though intervals up to 26 weeks have been described with subacute liver failure.<sup>4,21,22</sup> A subset of ALF definitions require patients to demonstrate evidence of impaired endogenous hepatic function, typically International Normalized Ratio (INR)  $\geq 1.5$ .<sup>21</sup> Finally, the notion of absence of pre-existing liver disease has been challenged by the inclusion of patients with chronic liver disease without overt cirrhosis (i.e. Wilson's Disease, reactivation of chronic HBV infection, presentation of autoimmune hepatitis, etc.) in some ALF studies.<sup>14</sup>

In 2011, the *American Association for the Study of Liver Disease* (AASLD) published a position paper statement defining ALF as “*evidence of coagulation abnormality, usually INR  $\geq 1.5$ , and any degree of mental alteration (encephalopathy) in a patient without pre-existing cirrhosis and with an illness of <26 weeks' duration.*”<sup>22</sup> For the purpose of this thesis research, the United States Acute Liver Failure Study Group

(US ALFSG) defines ALF as: (1) INR  $\geq 1.5$ , (2) HE of any grade (West Haven criteria), (3) illness onset less than 26 weeks from hepatic insult, and (4) absence of existing cirrhosis.

### **1.3 Epidemiology**

Estimates of ALF incidence and etiology vary greatly with geography. European and North American patient registries suggest 1-10 ALF cases per million persons per year, or approximately 2000-3000 cases annually within the United States.<sup>1,3</sup> Globally, hepatotropic viruses account for the majority of ALF cases and dominate in developing nations<sup>15</sup> In contrast, APAP-ALF represents 65.4% and 45.7% of cases in the United Kingdom (UK) and North America, respectively.<sup>1,7,23</sup>

Summarizing data reported by the US ALFSG, North American ALF patients tend to be young, female sex, previously healthy, and have a high prevalence of pre-existing psychiatric comorbidities<sup>1,7</sup>, reflecting primarily APAP-ALF patient demographics. The majority of APAP-ALF cases in the UK are the result of intentional overdose (i.e. self-harm), which has driven legislation to restrict over-the-counter access to APAP within the UK.<sup>24</sup> In contrast, half of North American cases are reported to be the result of therapeutic misadventure: repeated dosing of excessive APAP quantities to relieve somatic symptoms in the absence of suicidal intent.<sup>4,25-27</sup> Poorer outcomes have been reported in unintentional overdoses<sup>28-31</sup>; though, this suggestion remains controversial.<sup>27</sup>

## **1.4 Causes of Acute Liver Failure**

Despite a diverse range of causes, patients with ALF exhibit a similar clinical course associated with hepatocyte injury, diffuse systemic inflammatory response, worsening coma, and risk of MSOF.<sup>1</sup> Diagnosis of ALF and identification of underlying etiology is essential to direct treatment decisions.<sup>14</sup> In some instances, early therapy may promote overall survival or survival without the need of LT; for example: *N*-acetylcysteine (NAC) in both APAP-ALF and non-APAP ALF.<sup>32-34</sup> Certain etiologies predict poorer outcomes and are more likely to warrant early consideration of LT.<sup>22,35</sup> This is especially important in cases of subacute liver failure, where delayed ALF diagnosis may eliminate LT as a therapeutic option.<sup>14</sup> An understanding of common presenting features and their underlying mechanisms of injury is necessary among clinicians caring for ALF patients.

### **1.4.1 Acetaminophen Toxicity**

As previously discussed, APAP-ALF is the most common etiology in North America and Western Europe. Progression to ALF following excessive APAP ingestion is an uncommon complication and has been observed in 0.6% of patients presenting to emergency medicine departments in the UK.<sup>36</sup> Following single timepoint APAP overdose, hepatic transaminases (aspartate aminotransferase (AST) and alanine aminotransferase (ALT)) and INR rise within 24 hours. Often, elevations of AST and ALT and INR reach >10,000 IU/L and >4.0, respectively, and peak within 72-96 hours.<sup>26</sup> Extreme elevations of AST/ALT and INR in the setting of normal or slightly elevated

bilirubin is pathognomonic for APAP-ALF.<sup>37</sup> Patients may experience a rapid and unpredictable decline in clinical status, displaying hyperammonemia and coma, with a subset progressing to CE, uncal herniation, and cardiorespiratory collapse.<sup>14,26</sup> Despite the severity of illness associated with APAP-ALF, there remains potential for hepatic recovery.<sup>35</sup> Likelihood of TFS in APAP-ALF has been estimated at 65%.<sup>1</sup>

In 1973, Mitchell et al described the mechanism of hepatic injury in APAP-ALF.<sup>38</sup> With safe doses, APAP is predominantly bound to glucuronides or sulfates and renally excreted. At toxic doses, this metabolic pathway is saturated, with excess APAP oxidized by cytochrome P-450 enzymes to the reactive intermediate *N*-acetyl-*p*-benzoquinone imine (NAPQI). Toxic NAPQI may be bound to hepatic glutathione (GSH), rendering a benign molecule.<sup>26,38,39</sup> Enhanced production of NAPQI may be driven by ethanol or certain medications (secondary to promotion of cytochrome P-450 activity).<sup>40</sup> Furthermore, availability of hepatic GSH is reduced in patients with chronic ethanol abuse/malnutrition; thus, decreasing NAPQI detoxification capability.<sup>39</sup> As such, varying APAP dosages may lead to ALF, with excess NAPQI disrupting cellular integrity and rapidly inducing hepatocyte necrosis.<sup>26,29</sup> Administration of NAC in APAP-ALF replenishes hepatic GSH and decreases NAPQI. Evidence supports NAC provided within 12 hours of APAP ingestion prevents liver injury.<sup>32,33</sup>

### ***1.5 Critical Care Management***

Irrespective of etiology, ALF patients are critically ill and often require ICU admission within tertiary care hospitals capable of performing transplantation.<sup>14</sup> These patients are

prone to life-threatening complications, with progression to extrahepatic organ failure driven by the release of pro-inflammatory cytokines and damage-associated molecular patterns.<sup>41</sup> Unless spontaneous liver recovery occurs, death secondary to CE, MSOF, or sepsis is inevitable in the absence of LT. Advances in the critical care management of ALF have been instrumental in reducing mortality and, in some cases, may negate the need for LT.<sup>1,23</sup> Important organ system-based complications and appropriate management strategies are described below, including those endorsed by the AASLD (2011)<sup>22</sup>, the *European Association for the Study of the Liver* (2017)<sup>14</sup>, and the *Society of Critical Care Medicine* (2020).<sup>42</sup>

### **1.5.1 Neurologic Management**

In ALF, normal ammonia metabolism is compromised secondary to impaired hepatic function.<sup>43</sup> High levels of ammonia are metabolized to glutamine, disrupting the blood-brain barrier.<sup>44</sup> Resulting intracranial hypertension (ICH) may rapidly progress to coma, CE, brainstem herniation, and death—particularly in patients with *hyperacute* ALF presentation.<sup>5,6,43,45</sup> Though incidence of CE has been reported to have declined from 76% in 1984-1988 to 20% in 2004-2008, CE-related mortality still exceeds 20% and is a substantial cause of neurologic morbidity in ALF patients.<sup>23</sup>

Neurocritical care algorithms for ALF patients are well established. Endotracheal intubation and mechanical ventilation should be considered in all patients with decreased level of consciousness (i.e. Glasgow coma scale score  $\leq 8$ ). The need for sedating medications should be balanced between regular monitoring of neurological function and

reducing cerebral metabolic demand. Patients should be positioned with the head of bed elevated to 15-30°, avoiding painful stimuli when possible.<sup>46</sup> Mean arterial pressure (MAP) should be maintained  $\geq 75$  mm Hg using isotonic crystalloids and/or vasopressor support to maintain adequate cerebral perfusion pressure.<sup>22</sup> Prophylactic maintenance of serum sodium at 145-155 mmol/L with hypertonic saline may be considered in patients with high grade HE as this has been shown to reduce ICH.<sup>47</sup> Though previously recommended, induction of moderate hypothermia has no benefit in preventing CE or conferring survival advantage.<sup>48,49</sup> Intracranial pressure monitoring remains the gold standard for real-time detection of ICH; however, no associated mortality benefit has been demonstrated and use has declined over time.<sup>7,50-52</sup> For patients clinically demonstrating evidence of ICH/CE, intravenous administration of mannitol (0.5-1.0 g/kg dosing) or hypertonic saline is recommended, repeating as necessary, and consideration of deeper sedation.<sup>3,53,54</sup>

Increasing serum ammonia has been implicated in the development of HE and ICH<sup>55</sup>, while admission serum ammonia level is associated with both severity of HE and neurological mortality.<sup>56</sup> Given that acute kidney injury (AKI) frequently complicates ALF, ammonia clearance represents a promising management strategy.<sup>57</sup> In 2014, Slack et al described the ability of continuous renal replacement therapy (CRRT) to achieve a statistically significant reduction in serum ammonia level in a cohort of ALF and acute-on-chronic liver failure patients.<sup>58</sup> The role of CRRT in achieving significant ammonia clearance has since been validated in two additional ALF cohorts.<sup>56,59</sup> Notably, Cardoso et al reported an improvement in 21-day TFS was associated with CRRT, while a decrease in 21-day TFS was associated with intermittent hemodialysis (IHD).<sup>56</sup> In addition



to traditional indications, CRRT should be considered in all ALF patients with hyperammonemia or those deemed at high risk for ICH/CE.<sup>42,46,56</sup>

### **1.5.2 Hemodynamic Management**

Hemodynamic changes in ALF resemble that of distributive shock.<sup>60</sup> As systemic inflammatory response worsens, decreased effective circulating volume and hemodynamic instability result, further exacerbating hepatic and extrahepatic organ failures.<sup>14,22,42</sup>

Hemodynamic management of ALF patients must begin with an assessment of volume status. Patients frequently present with dehydration; thus, a trial of volume expansion with intravenous crystalloids is recommended. Should patients remain hypotensive, vasopressor therapy should be initiated to target a MAP >65-75 mm Hg.<sup>14,22,42,61</sup> Norepinephrine (0.01-0.3 µg/kg/min) is recommended as first-line vasopressor therapy.<sup>14,22,42</sup> Adjunctive vasopressin (0.01-0.04 units/minute) or vasopressin analogues may be considered, with a recent study comparing norepinephrine and terlipressin reporting no difference in resulting intracranial pressure.<sup>62</sup> Invasive hemodynamic monitoring is recommended in all ALF patients receiving vasopressor support.<sup>42</sup> Echocardiography may serve as a useful adjunct, as development of volume overload is equally harmful in ALF patients.<sup>14,42</sup> In cases of refractory shock, relative adrenal insufficiency should be considered.<sup>63</sup> Hydrocortisone administration has been shown to reduce vasopressor requirements in ALF and critically ill patients, though its role in reducing mortality remains contentious.<sup>14,42,61,64-66</sup>

### **1.5.3 Renal Management**

Acute kidney injury is a common complication of ALF. Incidence of AKI in ALF has been estimated at 70%, with 30% of patients requiring RRT.<sup>57</sup> Notably, AKI mechanism is multifactorial and varies with underlying ALF cause. Pre-renal azotemia may contribute, as ALF patients frequently present with hypovolemia and decreased effective circulating volume. Hypoperfusion may promote renal ischemia and further induce acute tubular necrosis.<sup>22</sup> In APAP-ALF, APAP is felt to have a direct nephrotoxic effect<sup>67,68</sup>, with elevations in serum creatine observed in up to 70% of patients.<sup>57</sup> Other hepatotoxins, including amatoxin, certain antibiotics (i.e. sulfonamides, macrolides, etc.), and copper, may induce tubular injury.<sup>1</sup>

Management of AKI in ALF should begin with cessation of nephrotoxic medications and a trial of volume expansion, followed by vasopressor support to maintain MAP and renal perfusion, if necessary.<sup>14,22,42,69</sup> Traditional indications for RRT still apply<sup>70</sup>; however, early initiation of renal replacement therapy (RRT) is now recommended in ALF as CRRT has been associated with improved TFS in ALF.<sup>42,56</sup> This may relate to protection against ICH/CE, as CRRT provides significant ammonia clearance without the hemodynamic swings associated with IHD.<sup>56,58,59,71</sup> Consequently, IHD should be avoided in ALF as it has been associated with increased mortality.<sup>56</sup> Evidence surrounding optimal timing of CRRT is deficient; however, early initiation should be considered in ALF patients with elevated/increasing serum ammonia levels or those with ICH/CE, regardless of serum creatinine.<sup>1,14,42,56</sup>

## ***1.6 Liver Transplantation***

For patients failing medical therapy, LT may serve as definitive management. Prior to 1980, overall survival in ALF patients did not exceed 20%.<sup>23</sup> With the availability of LT and improved intensive care management algorithms, overall survival now approaches 70%, with approximately one-quarter of ALF patients receiving LT over the last decade.<sup>7,17,23,46</sup> Immediate post-LT mortality in ALF patients exceeds that of cirrhotics and likely reflects acuity of illness, possible delayed presentation, and frequent CE and MSOF.<sup>1</sup> Though lifesaving, finite availability of donor organs, psychosocial issues, and futility limit the use of LT in ALF. Despite this, comparable survival rates have been reported beyond one year following LT in transplanted ALF patients and cirrhotics.<sup>72</sup> Recurrent self-harm and poor compliance and follow-up represent potential problems in post-LT APAP-ALF patients; however, long-term outcomes post-LT are similar to those of non-APAP ALF patients.<sup>73</sup>

## ***1.7 Prognosis in Acute Liver Failure***

Determining prognosis is pivotal in the critical care management of ALF.<sup>46</sup> Some patients may survive with their native livers, while others may face inevitable mortality regardless of LT.<sup>4</sup> Transplantation listing algorithms aim to identify patients whose survival would only be expected with LT over medical management alone.<sup>3</sup> Prognostic indices must be sensitive to capture ALF patients that would benefit from LT, while maintaining sufficient specificity to not lead to unnecessary LT.<sup>74</sup> The most important predictors of favourable

outcome in ALF are etiology and HE coma grade on admission.<sup>75</sup> Numerous prognostic indices have been developed around these parameters; however, current LT decisions predominately rely on consensus among intensivists, hepatologists, and surgeons.

The most commonly used prognostic index remains the King's College Criteria (KCC).<sup>76</sup> The KCC were developed to identify any patient at high risk of mortality in ALF (and, by extension, said patients were presumed to likely need LT). These criteria have since been found to have high specificity, but low sensitivity and negative predictive value (i.e. may fail to identify some ALF patients who will die without LT, or falsely select for some who may ultimately survive without LT).<sup>25,35,74,75,77,78</sup> A recent meta-analysis found the KCC, compared with the Model for End-stage Liver Disease (MELD) score, to better predict hospital mortality in APAP-ALF; however, the reverse was found in non-APAP ALF.<sup>74</sup> Recently, the US ALFSG prognostic index (ALFSG-PI) was developed to predict likelihood of TFS using data from 1974 ALF patients.<sup>75</sup> Admission values of HE coma grade, etiology, vasopressor use, INR, and bilirubin were significantly associated with TFS. Notably, ALFSG-PI was found to outperform both KCC and MELD in predicting TFS in ALF; however, external validation remains necessary.<sup>75</sup> Overall, rates of TFS have improved with time, likely reflecting advances in critical care management.<sup>7,23</sup> Etiology continues to play a large role in prognosis, with APAP, hepatitis A virus, acute fatty liver of pregnancy, and ischemia-induced ALF conferring greater TFS over other causes.<sup>4</sup>

## **1.8 Extracorporeal Liver Support**

### **1.8.1 Overview of Extracorporeal Liver Support in ALF**

Despite advances in medical management, mortality in ALF remains high. Extracorporeal liver support systems represent a promising therapeutic strategy. As the liver possesses potential for regeneration, ECLS systems are hypothesized to supplement native hepatic function until organ recovery occurs. Alternatively, in patients failing to respond to medical therapy, ECLS may sustain patients until donor graft availability.<sup>10,11</sup> To achieve these goals, ECLS systems aim to replicate endogenous detoxification and biosynthetic functions.<sup>79</sup> *Artificial* (cell-free) ECLS systems utilize adsorption and filtration to detoxify patient blood through the removal of hydrophilic and albumin-bound toxins.<sup>80</sup> *Bioartificial* ECLS systems further incorporate living hepatocytes into bioreactors to perform hepatic functions that are compromised in ALF.<sup>81-83</sup>

As a consequence of impaired hepatic function, numerous cytotoxic substances accumulate and contribute to HE, MSOF, and systemic inflammatory response.<sup>3,43,84,85</sup> Traditional renal hemodialysis (HD) and hemofiltration (HF) circuits are capable of removing small hydrophilic toxins (i.e. ammonia)<sup>56,58,59</sup>; however, many accumulating toxins in ALF are hydrophobic and bound by serum albumin.<sup>84</sup> As such, certain artificial ECLS systems incorporate an albumin-based dialysate circuit which removes albumin-bound toxins (note: utilize an albumin-impermeable membrane; thus, serum albumin remains in blood circuit). These systems include the Molecular Adsorbent Recirculating System (MARS; Baxter International Inc., Deerfield, USA) and single pass albumin

dialysis.<sup>86,87</sup> In contrast, fractionated plasma separation and adsorption or Prometheus (Fresenius Medical Care, Bad Homburg, Germany) employs an albumin-permeable membrane, separating patient plasma, and subsequently cleansing serum albumin before being returned to the blood circuit.<sup>88</sup> Finally, high-volume plasmapheresis (HVP; also referred to as *high volume plasma exchange*) involves the removal of patient plasma, including pro-inflammatory response mediators, albumin, and albumin-bound toxins, and replacement with fresh frozen plasma.<sup>9,89</sup>

In terms of bioartificial ECLS systems, two main devices have been examined in ALF patients: the human hepatoblastoma cell-based Extracorporeal Liver Assist Device (ELAD; Vital Therapies Inc., San Diego, United States) and the porcine hepatocyte-based HepatAssist (Alliqua Biomedical Inc., Langhorne, United States).<sup>90-92</sup> Many novel bioartificial ECLS devices have been developed; however, results from large clinical trials are pending.<sup>10</sup> Landmark trials surrounding the use of artificial and bioartificial ECLS systems in ALF patients are described below and summarized in Table 1.1.

### ***1.8.2 Artificial ECLS: Molecular Adsorbent Recirculating System in ALF***

Developed by Stange and Mitzner, the MARS device was first described in 1993.<sup>86</sup> Briefly, MARS consists of two parallel circuits utilizing countercurrent flow: a proprietary albumin circuit and a renal circuit (note: renal circuit incorporates a standard HD or HF RRT system); in addition to the patient blood circuit (Figure 1.1). Patient blood is dialyzed against a 20% albumin solution using a 50 kDa-pored, albumin-impermeable, high-flux membrane. Small hydrophilic and albumin-bound substances are transferred to the

albumin dialysate, which is subsequently filtered against a traditional low-flux RRT circuit. The partially-cleansed albumin dialysate then passes through activated charcoal-containing and anion-exchange resin-containing columns to remove remaining albumin-bound toxins. The restored albumin dialysate is then recirculated against patient blood.<sup>80,84,86,93,94</sup>

To date, the MARS device represents the most-studied ECLS system in ALF. Treatment with MARS has been shown to improve biochemical (including bilirubin, creatinine, lactate, and ammonia), and hemodynamic (increased systemic vascular resistance index and MAP) parameters.<sup>95-97</sup> The largest study on MARS in ALF was reported by Saliba et al in 2013 (FULMAR Trial).<sup>96</sup> As part of this multicentre randomized controlled trial, 102 ALF patients were allocated to receive MARS and SMT (n=53) or SMT alone (n=49). Primary endpoint evaluated was 6-month survival (independent of LT status). In a modified intention-to-treat analysis, 6-month survival did not differ between MARS and SMT group patients (84.9% vs. 75.5%; p=0.28), nor did 6-month TFS (18.9% vs. 26.5%; p=0.35). Importantly, median listing-to-transplant time was 16.2 hours, with a large subset of MARS patients receiving no (n=7) or <5 hours of (n=7) treatment. High rates of LT—73.5% within 72 hours of enrollment among MARS patients—limited delivery of MARS therapy and potentially confounded this study's assessment of MARS. Considering ALF etiology, the authors noted that APAP-ALF patients displayed clinically, though not statistically, greater 6-month survival following MARS (85% vs. 68.4%; p=0.46). Regardless, the trial was not sufficiently powered to explore this subgroup.<sup>96</sup>

### **1.8.3 Artificial ECLS: High-Volume Plasmapheresis in ALF**

High-volume plasmapheresis has previously been reported to improve HE severity and hemodynamic parameters in ALF.<sup>98,99</sup> Larsen et al reported the results of a multicentre randomized controlled trial examining the role of HVP in ALF.<sup>100</sup> Patients were randomized to receive SMT and HVP (n=92) or SMT alone (n=90) for three days. Stratifying for LT status, non-transplanted HVP-treated patients displayed significantly increased survival (hazard ratio: 0.56; 95% CI: 0.36-0.86; p=0.0083). No survival advantage was noted between treatment groups in patients who ultimately received LT. Furthermore, following HVP, the authors reported reductions in circulating damage-associated molecular patterns and pro-inflammatory mediators of immune response.<sup>80</sup> To date, this remains the only study demonstrating an ECLS-associated TFS advantage in ALF patients.

### **1.8.4 Bioartificial ECLS: HepatAssist in ALF**

In a study by Demetriou et al, 171 ALF patients were randomized to receive HepatAssist (n=85) or SMT (n=86).<sup>92</sup> Evaluating survival at 30 days, no survival difference was observed following HepatAssist treatment compared with SMT (70.6% vs. 61.6%; p=0.259), nor following adjustment for potential confounders (relative risk in HepatAssist patients: 0.67; p=0.13). Stratification for transplantation status (transplanted: 88.9% vs. 79.6%; p=0.22; and non-transplanted: 50.0% vs. 37.8%; p=0.38) and exclusion of primary non-functioning graft patients (n=147 remaining; 72.6% vs. 59.5%; p=0.117) failed to



reveal a subgroup survival advantage associated with HepatAssist treatment. Ultimately, the trial was ended secondary to perceived futility in evaluating the primary outcome.

#### ***1.8.5 Bioartificial ECLS: Extracorporeal Liver Assist Device in ALF***

Building on a pilot study in 24 ALF patients failing to reveal an ELAD-related survival advantage over SMT<sup>91</sup>, Thompson et al published the results of the anticipated VTI-208 randomized controlled trial in 2018.<sup>101</sup> Notably, the VTI-208 trial did not examine overt ALF patients; rather, severe alcoholic hepatitis patients (defined as 6 weeks between the last intake of alcohol and rapid onset of jaundice and coagulopathy (Maddrey's discriminant function  $\geq 32$ )) with MELD  $\leq 35$  were enrolled. Of 203 patients, 47.8% (n=97) had documented HE (defined using West Haven criteria; HE grade  $\geq 1$ ). Patients were randomized to receive ELAD and SMT (n=96) or SMT alone (n=107). Primary endpoint evaluated was overall survival beyond day 91. Following intention-to-treat Kaplan-Meier analysis, no difference in survival was observed between ELAD and SMT patients (hazard ratio: 1.03; 95% CI: 0.69-1.53; p=0.90). As part of a subgroup analysis, the authors noted a trend towards improved survival in participants with MELD  $< 28$  (n=120; hazard ratio: 0.58; p=0.08); however, further study remains necessary to fully evaluate this suggestion.

## **1.9 Statement of the Problem and Objectives**

As a result of its rarity and etiologic heterogeneity, research surrounding the critical care management of ALF and its impact on important clinical outcomes remains limited and has largely been based on non-ALF critical care literature.<sup>4</sup> Controlled trials in ALF patients remain both ethically and practically challenging, underscoring the need for novel large-scale multicentre descriptive studies with standardized management algorithms.<sup>1</sup> Within North America and Europe, APAP-ALF remains the predominant ALF variant. Given the shortage of donor organs available for LT, and the severity of critical illness/presence of psychosocial factors frequently precluding LT, determining the role of evolving critical care medical management (i.e. nonoperative) strategies in APAP-ALF is needed. The role of ECLS systems in ALF remains of interest. Apart from HVP, prior ECLS studies, including MARS in APAP-ALF (FULMAR), have been under-powered and have only suggested a potential association with survival in subgroup analyses.<sup>92,96,101</sup> Furthermore, as LT serves as a competing risk in ALF patients, evaluating an ECLS device's potential role in TFS, rather than overall survival, may be of value. A large-scale study evaluating the role of MARS in ALF in terms of TFS is lacking.

As such, this thesis research aimed to address the following objectives:

1. Describe the natural history of APAP-ALF in a large North American patient cohort, and evaluate changes in clinical interventions, psychosocial profile, and important clinical outcomes (TFS and development of ICH/CE) over time.

2. Evaluate the role of MARS, compared to SMT, in all-etiology ALF, and its implications on spontaneous survival (TFS).

The first objective was met through completion of a multicentre retrospective cohort study of all APAP-ALF patients enrolled within the US ALFSG between 1998 and 2018 (Chapter 2). The second objective was met through completion of a multicentre retrospective cohort study of ALF patients receiving MARS at three major North American tertiary care hospitals between 2009 and 2019, propensity-matched to SMT patients enrolled within the US ALFSG, reporting associations with TFS in MARS-treated versus SMT-treated ALF patients (Chapter 3).

**Table 1.1.** Summary of landmark trials on the use of artificial and bioartificial extracorporeal liver support systems in acute liver failure.

Study	ECLS Device	Design	N	Survival (ECLS vs. control)	Biochemical and Hemodynamic Outcomes (ECLS vs. control)
<b>Artificial</b>					
“FULMAR” <i>Saliba et al</i> <sup>96</sup>	MARS	RCT	MARS: n=53 SMT: n=49	6-month survival <sup>a</sup> : 84.9% vs. 75.5% (p=0.28)	N/A <sup>b</sup>
<i>Larsen et al</i> <sup>100</sup>	HVP	RCT	HVP: n=92 SMT: n=90	Hospital survival: 58.7% vs. 47.8% (p=0.0083) <sup>c</sup>	Decreased INR, bilirubin, and ammonia  Increased MAP and decreased vasopressor dosing
<b>Bioartificial</b>					
<i>Demetriou et al</i> <sup>92</sup>	Hepat-Assist	RCT	ECLS: n=85 SMT: n=86	30-day survival: 70.6% vs. 61.6% (p=0.259)	Decreased bilirubin
“VTI-208” <i>Thompson et al</i> <sup>101d</sup>	ELAD	RCT	ELAD: n=96 SMT: n=107	91-day survival <sup>e</sup> : 59.4% vs. 61.7% <sup>f</sup> (p=NS)	Decreased bilirubin

Abbreviations: *ECLS*, extracorporeal liver support; *ELAD*, extracorporeal liver assist device; *HVP*, high volume plasmapheresis; *INR*, international normalized ratio; *MAP*, mean arterial pressure; *MARS*, molecular adsorbent recirculating system; *N/A*, not assessed; *NS*, not significant; *RCT*, randomized controlled trial; *SMT*, standard medical therapy.

- <sup>a</sup> Secondary analysis reported 6-month survival among acetaminophen-induced acute liver failure patient subgroup: MARS: 85% vs. SMT: 68.4% (p=0.46).
- <sup>b</sup> Significant reductions in bilirubin, urea, and creatinine were reported following treatment in MARS group patients. No data reported for SMT group patients.
- <sup>c</sup> HVP-related survival advantage only significant in those not receiving liver transplant.
- <sup>d</sup> Enrolled patients with *severe alcoholic hepatitis* (6 weeks between the last intake of alcohol and rapid onset of jaundice (serum bilirubin  $\geq 137$   $\mu\text{mol/L}$ ) and coagulopathy (Maddrey's discriminant function  $\geq 32$ )), with or without chronic liver disease. Patients were not required to meet established acute liver failure diagnostic criteria (i.e. those of the *United States Acute Liver Failure Study Group*).
- <sup>e</sup> Primary outcome: Kaplan-Meier analysis for overall survival (including follow-up beyond day 91): hazard ratio: 1.03 (p=0.90), with 47.9% death rate in the ELAD group and 47.7% in the SMT group.
- <sup>f</sup> Secondary outcome: survival proportions at day 91 (p-value not reported).

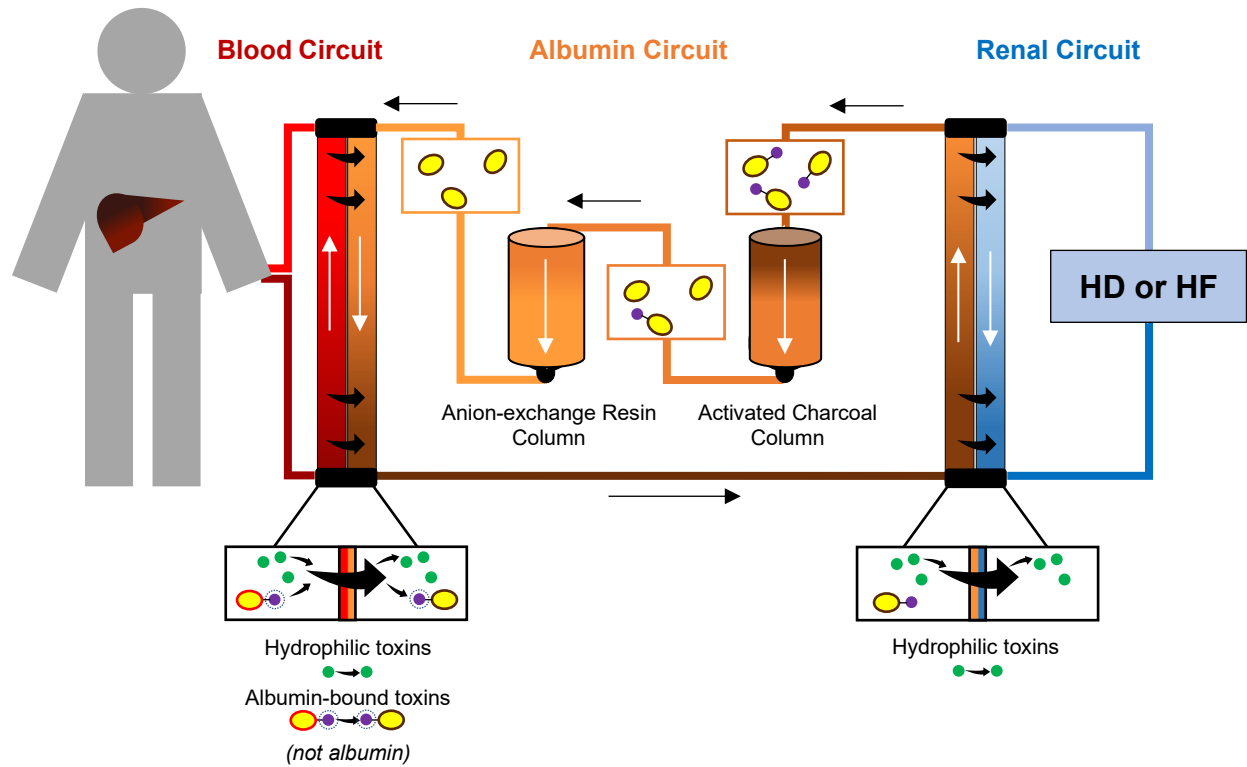

**Figure 1.1.** Schematic of the molecular adsorbent recirculating system device setup.

Abbreviations: *HD*, hemodialysis; *HF*, hemofiltration.

## **1.10 References**

1. Stravitz RT, Lee WM. Acute liver failure. *Lancet* 2019;394:869-81.
2. O'Grady JG, Williams R. Classification of acute liver failure. *Lancet* 1993;342:743.
3. Bernal W, Wendon J. Acute liver failure. *N Engl J Med* 2013;369:2525-34.
4. Lee WM. Acute liver failure. *Semin Respir Crit Care Med* 2012;33:36-45.
5. Ware AJ, D'Agostino AN, Combes B. Cerebral edema: a major complication of massive hepatic necrosis. *Gastroenterology* 1971;61:877-84.
6. Bernal W, Wendon J. Acute liver failure; clinical features and management. *Eur J Gastroenterol Hepatol* 1999;11:977-84.
7. Reuben A, Tillman H, Fontana RJ, et al. Outcomes in adults with acute liver failure between 1998 and 2013: an observational cohort study. *Ann Intern Med* 2016;164:724-32.
8. O'Grady JG, Wendon J, Tan KC, et al. Liver transplantation after paracetamol overdose. *BMJ* 1991;303:221-3.
9. Lee KC, Stadlbauer V, Jalan R. Extracorporeal liver support devices for listed patients. *Liver Transpl* 2016;22:839-48.
10. Katarey D, Jalan R. Update on extracorporeal liver support. *Curr Opin Crit Care* 2020;26:180-5.
11. Jalan R, Sen S, Williams R. Prospects for extracorporeal liver support. *Gut* 2004;53:890-8.

12. Trey C, Davidson CS. The management of fulminant hepatic failure. *Prog Liver Dis* 1970;3:282-98.
13. O'Grady JG, Schalm SW, Williams R. Acute liver failure: redefining the syndromes. *The Lancet* 1993;342:273-5.
14. Wendon J, Cordoba J, Dhawan A, et al. EASL clinical practical guidelines on the management of acute (fulminant) liver failure. *J Hepatol* 2017;66:1047-81.
15. Dhiman RK, Seth AK, Jain S, Chawla YK, Dilawari JB. Prognostic evaluation of early indicators in fulminant hepatic failure by multivariate analysis. *Dig Dis Sci* 1998;43:1311-6.
16. Bernal W, Auzinger G, Dhawan A, Wendon J. Acute liver failure. *The Lancet* 2010;376:190-201.
17. Ostapowicz G, Fontana RJ, Schiodt FV, et al. Results of a prospective study of acute liver failure at 17 tertiary care centers in the United States. *Ann Intern Med* 2002;137:947-54.
18. Bernuau J, Rueff B, Benhamou JP. Fulminant and subfulminant liver failure: definitions and causes. *Semin Liver Dis* 1986;6:97-106.
19. Mochida S, Nakayama N, Matsui A, Nagoshi S, Fujiwara K. Re-evaluation of the guideline published by the Acute Liver Failure Study Group of Japan in 1996 to determine the indications of liver transplantation in patients with fulminant hepatitis. *Hepatol Res* 2008;38:970-9.
20. Tandon BN, Bernuau J, O'Grady J, et al. Recommendations of the International Association for the Study of the Liver subcommittee on nomenclature of acute and subacute liver failure. *J Gastroenterol Hepatol* 1999;14:403-4.



21. Wlodzimirow KA, Eslami S, Abu-Hanna A, Nieuwoudt M, Chamuleau RA. Systematic review: acute liver failure - one disease, more than 40 definitions. *Aliment Pharmacol Ther* 2012;35:1245-56.
22. Lee WM, Stravitz RT, Larson AM. Introduction to the revised American Association for the Study of Liver Diseases position paper on acute liver failure 2011. *Hepatology* 2012;55:965-7.
23. Bernal W, Hyyrylainen A, Gera A, et al. Lessons from look-back in acute liver failure? A single centre experience of 3300 patients. *J Hepatol* 2013;59:74-80.
24. Bernal W. Changing patterns of causation and the use of transplantation in the United Kingdom. *Semin Liver Dis* 2003;23:227-37.
25. Lee WM. Acute liver failure in the United States. *Semin Liver Dis* 2003;23:217-26.
26. Lee WM. Acetaminophen (APAP) hepatotoxicity-isn't it time for APAP to go away? *J Hepatol* 2017;67:1324-31.
27. Larson AM, Polson J, Fontana RJ, et al. Acetaminophen-induced acute liver failure: results of a United States multicenter, prospective study. *Hepatology* 2005;42:1364-72.
28. Zimmerman HJ, Maddrey WC. Acetaminophen (paracetamol) hepatotoxicity with regular intake of alcohol: analysis of instances of therapeutic misadventure. *Hepatology* 1995;22:767-73.
29. Maddrey WC. Hepatic effects of acetaminophen. Enhanced toxicity in alcoholics. *J Clin Gastroenterol* 1987;9:180-5.

30. Whitcomb DC, Block GD. Association of acetaminophen hepatotoxicity with fasting and ethanol use. *JAMA* 1994;272:1845-50.
31. Schiodt FV, Rochling FA, Casey DL, Lee WM. Acetaminophen toxicity in an urban county hospital. *N Engl J Med* 1997;337:1112-7.
32. Harrison PM, Wendon JA, Gimson AE, Alexander GJ, Williams R. Improvement by acetylcysteine of hemodynamics and oxygen transport in fulminant hepatic failure. *N Engl J Med* 1991;324:1852-7.
33. Keays R, Harrison PM, Wendon JA, et al. Intravenous acetylcysteine in paracetamol induced fulminant hepatic failure: a prospective controlled trial. *BMJ* 1991;303:1026-9.
34. Lee WM, Hynan LS, Rossaro L, et al. Intravenous N-acetylcysteine improves transplant-free survival in early stage non-acetaminophen acute liver failure. *Gastroenterology* 2009;137:856-64, 64 e1.
35. Simpson KJ, Bates CM, Henderson NC, et al. The utilization of liver transplantation in the management of acute liver failure: comparison between acetaminophen and non-acetaminophen etiologies. *Liver Transpl* 2009;15:600-9.
36. Jones A. Over-the-counter analgesics: a toxicology perspective. *Am J Ther* 2002;9:245-57.
37. Nourjah P, Ahmad SR, Karwoski C, Willy M. Estimates of acetaminophen (paracetamol)-associated overdoses in the United States. *Pharmacoepidemiol Drug Saf* 2006;15:398-405.

38. Mitchell JR, Jollow DJ, Potter WZ, Davis DC, Gillette JR, Brodie BB. Acetaminophen-induced hepatic necrosis. I. Role of drug metabolism. *J Pharmacol Exp Ther* 1973;187:185-94.
39. Lancaster EM, Hiatt JR, Zarrinpar A. Acetaminophen hepatotoxicity: an updated review. *Arch Toxicol* 2015;89:193-9.
40. Bunchorntavakul C, Reddy KR. Acetaminophen-related hepatotoxicity. *Clin Liver Dis* 2013;17:587-607, viii.
41. Chung RT, Stravitz RT, Fontana RJ, et al. Pathogenesis of liver injury in acute liver failure. *Gastroenterology* 2012;143:e1-e7.
42. Nanchal R, Subramanian R, Karvellas CJ, et al. Guidelines for the management of adult acute and acute-on-chronic liver failure in the ICU: cardiovascular, endocrine, hematologic, pulmonary, and renal considerations. *Critical Care Medicine* 2020;48:e173-e91.
43. Wijdicks EF. Hepatic encephalopathy. *N Engl J Med* 2016;375:1660-70.
44. Albrecht J, Norenberg MD. Glutamine: a Trojan horse in ammonia neurotoxicity. *Hepatology* 2006;44:788-94.
45. Butterworth RF, Giguere JF, Michaud J, Lavoie J, Layrargues GP. Ammonia: key factor in the pathogenesis of hepatic encephalopathy. *Neurochem Pathol* 1987;6:1-12.
46. Trovato FM, Rabinowich L, McPhail MJW. Update on the management of acute liver failure. *Curr Opin Crit Care* 2019;25:157-64.
47. Murphy N, Auzinger G, Bernel W, Wendon J. The effect of hypertonic sodium chloride on intracranial pressure in patients with acute liver failure. *Hepatology* 2004;39:464-70.

48. Bernal W, Murphy N, Brown S, et al. A multicentre randomized controlled trial of moderate hypothermia to prevent intracranial hypertension in acute liver failure. *J Hepatol* 2016;65:273-9.
49. Karvellas CJ, Todd Stravitz R, Battenhouse H, Lee WM, Schilsky ML, US Acute Liver Failure Study Group. Therapeutic hypothermia in acute liver failure: a multicenter retrospective cohort analysis. *Liver Transpl* 2015;21:4-12.
50. Blei AT, Olafsson S, Webster S, Levy R. Complications of intracranial pressure monitoring in fulminant hepatic failure. *Lancet* 1993;341:157-8.
51. Vaquero J, Fontana RJ, Larson AM, et al. Complications and use of intracranial pressure monitoring in patients with acute liver failure and severe encephalopathy. *Liver Transpl* 2005;11:1581-9.
52. Karvellas CJ, Fix OK, Battenhouse H, et al. Outcomes and complications of intracranial pressure monitoring in acute liver failure: a retrospective cohort study. *Crit Care Med* 2014;42:1157-67.
53. Canalese J, Gimson AE, Davis C, Mellon PJ, Davis M, Williams R. Controlled trial of dexamethasone and mannitol for the cerebral oedema of fulminant hepatic failure. *Gut* 1982;23:625-9.
54. Wendon J, Lee W. Encephalopathy and cerebral edema in the setting of acute liver failure: pathogenesis and management. *Neurocrit Care* 2008;9:97-102.
55. Bernal W, Hall C, Karvellas CJ, Auzinger G, Sizer E, Wendon J. Arterial ammonia and clinical risk factors for encephalopathy and intracranial hypertension in acute liver failure. *Hepatology* 2007;46:1844-52.

56. Cardoso FS, Gottfried M, Tujios S, Olson JC, Karvellas CJ, US Acute Liver Failure Study Group. Continuous renal replacement therapy is associated with reduced serum ammonia levels and mortality in acute liver failure. *Hepatology* 2018;67:711-20.
57. Tujios SR, Hynan LS, Vazquez MA, et al. Risk factors and outcomes of acute kidney injury in patients with acute liver failure. *Clin Gastroenterol Hepatol* 2015;13:352-9.
58. Slack AJ, Auzinger G, Willars C, et al. Ammonia clearance with haemofiltration in adults with liver disease. *Liver Int* 2014;34:42-8.
59. Warrillow S, Fisher C, Bellomo R. Correction and control of hyperammonemia in acute liver failure: the impact of continuous renal replacement timing, intensity, and duration. *Crit Care Med* 2020;48:218-24.
60. Rajaram P, Subramanian R. Management of acute liver failure in the intensive care unit setting. *Clin Liver Dis* 2018;22:403-8.
61. Rhodes A, Evans LE, Alhazzani W, et al. Surviving sepsis campaign: international guidelines for management of sepsis and septic shock: 2016. *Crit Care Med* 2017;45:486-552.
62. Eefsen M, Dethloff T, Frederiksen HJ, Hauerberg J, Hansen BA, Larsen FS. Comparison of terlipressin and noradrenalin on cerebral perfusion, intracranial pressure and cerebral extracellular concentrations of lactate and pyruvate in patients with acute liver failure in need of inotropic support. *J Hepatol* 2007;47:381-6.
63. Harry R, Auzinger G, Wendon J. The clinical importance of adrenal insufficiency in acute hepatic dysfunction. *Hepatology* 2002;36:395-402.

64. Harry R, Auzinger G, Wendon J. The effects of supraphysiological doses of corticosteroids in hypotensive liver failure. *Liver Int* 2003;23:71-7.
65. Etogo-Asse FE, Vincent RP, Hughes SA, et al. High density lipoprotein in patients with liver failure; relation to sepsis, adrenal function and outcome of illness. *Liver Int* 2012;32:128-36.
66. Karkhanis J, Verna EC, Chang MS, et al. Steroid use in acute liver failure. *Hepatology* 2014;59:612-21.
67. O'Riordan A, Brummell Z, Sizer E, et al. Acute kidney injury in patients admitted to a liver intensive therapy unit with paracetamol-induced hepatotoxicity. *Nephrol Dial Transplant* 2011;26:3501-8.
68. Waring WS, Jamie H, Leggett GE. Delayed onset of acute renal failure after significant paracetamol overdose: a case series. *Hum Exp Toxicol* 2010;29:63-8.
69. Polson J, Lee WM. AASLD position paper: the management of acute liver failure. *Hepatology* 2005;41:1179-97.
70. Bagshaw SM, Wald R. Acute kidney injury: timing of renal replacement therapy in AKI. *Nat Rev Nephrol* 2016;12:445-6.
71. Davenport A, Will EJ, Davidson AM. Improved cardiovascular stability during continuous modes of renal replacement therapy in critically ill patients with acute hepatic and renal failure. *Crit Care Med* 1993;21:328-38.
72. Fontana RJ, Ellerbe C, Durkalski VE, et al. Two-year outcomes in initial survivors with acute liver failure: results from a prospective, multicentre study. *Liver Int* 2015;35:370-80.

73. Germani G, Theocharidou E, Adam R, et al. Liver transplantation for acute liver failure in Europe: outcomes over 20 years from the ELTR database. *J Hepatol* 2012;57:288-96.
74. McPhail MJ, Farne H, Senvar N, Wendon JA, Bernal W. Ability of King's College Criteria and Model for End-Stage Liver Disease scores to predict mortality of patients with acute liver failure: a meta-analysis. *Clin Gastroenterol Hepatol* 2016;14:516-25 e5; quiz e43-e45.
75. Koch DG, Tillman H, Durkalski V, Lee WM, Reuben A. Development of a model to predict transplant-free survival of patients with acute liver failure. *Clin Gastroenterol Hepatol* 2016;14:1199-206 e2.
76. O'Grady JG, Alexander GJ, Hayllar KM, Williams R. Early indicators of prognosis in fulminant hepatic failure. *Gastroenterology* 1989;97:439-45.
77. Bailey B, Amre DK, Gaudreault P. Fulminant hepatic failure secondary to acetaminophen poisoning: a systematic review and meta-analysis of prognostic criteria determining the need for liver transplantation. *Crit Care Med* 2003;31:299-305.
78. Renner EL. How to decide when to list a patient with acute liver failure for liver transplantation? Clichy or King's College criteria, or something else? *J Hepatol* 2007;46:554-7.
79. Nyberg SL. Bridging the gap: Advances in artificial liver support. *Liver Transplantation* 2012;18:S10-S4.
80. Larsen FS. Artificial liver support in acute and acute-on-chronic liver failure. *Curr Opin Crit Care* 2019;25:187-91.

81. Allen JW, Hassanein T, Bhatia SN. Advances in bioartificial liver devices. *Hepatology* 2001;34:447-55.
82. Cao S, Esquivel CO, Keeffe EB. New approaches to supporting the failing liver. *Annual Review of Medicine* 1998:85-94.
83. Park J-k, Lee D-h. Bioartificial liver systems: current status and future perspective. *Journal of Bioscience and Bioengineering* 2005;99:311-9.
84. Mitzner S, Klammt S, Stange J, Schmidt R. Albumin regeneration in liver support—comparison of different methods. *Therapeutic Apheresis and Dialysis* 2006;10:108-17.
85. Khamri W, Abeles RD, Hou TZ, et al. Increased expression of cytotoxic T-lymphocyte-associated protein 4 by T cells, induced by B7 in sera, reduces adaptive immunity in patients with acute liver failure. *Gastroenterology* 2017;153:263-76 e8.
86. Stange J, Ramlow W, Mitzner S, Schmidt R, Klinkmann H. Dialysis against a recycled albumin solution enables the removal of albumin-bound toxins. *Artificial Organs* 1993;17:809-13.
87. Karvellas CJ, Bagshaw SM, Mcdermid RC, Stollery DE, Gibney RT. Acetaminophen-induced acute liver failure treated with single-pass albumin dialysis: report of a case. *The International Journal of Artificial Organs* 2008;31:450-5.
88. Falkenhagen D, Strobl W, Vogt G, et al. Fractionated plasma separation and adsorption system: a novel system for blood purification to remove albumin bound substances. *Artificial Organs* 1999;23:81-6.



89. Winters JL. Plasma exchange: concepts, mechanisms, and an overview of the American Society for Apheresis guidelines. *ASH Education Program Book 2012*;2012:7-12.
90. Sussman NL, Chong MG, Koussayer T, et al. Reversal of fulminant hepatic failure using an extracorporeal liver assist device. *Hepatology* 1992;16:60-5.
91. Ellis AJ, Hughes RD, Wendon JA, et al. Pilot-controlled trial of the extracorporeal liver assist device in acute liver failure. *Hepatology* 1996;24:1446-51.
92. Demetriou AA, Brown RS, Busuttil RW, et al. Prospective, randomized, multicenter, controlled trial of a bioartificial liver in treating acute liver failure. *Annals of Surgery* 2004;239:660-70.
93. Stange J, Mitzner SR, Risler T, et al. Molecular adsorbent recycling system (MARS): clinical results of a new membrane-based blood purification system for bioartificial liver support. *Artif Organs* 1999;23:319-30.
94. Mitzner SR, Stange J, Klammt S, et al. Improvement of hepatorenal syndrome with extracorporeal albumin dialysis mars: Results of a prospective, randomized, controlled clinical trial. *Liver Transplantation* 2000;6:277-86.
95. Novelli G, Rossi M, Pretagostini R, et al. MARS (molecular adsorbent recirculating system): experience in 34 cases of acute liver failure. *Liver* 2002;22:43-7.
96. Saliba F, Camus C, Durand F, Mathurin P, et al. Albumin dialysis with a noncell artificial liver support device in patients with acute liver failure: a randomized, controlled trial. *Annals of Internal Medicine* 2013;159:522-31.
97. Schmidt LE, Wang LP, Hansen BA, Larsen FS. Systemic hemodynamic effects of treatment with the molecular adsorbents recirculating system in patients with

hyperacute liver failure: a prospective controlled trial. *Liver Transplantation* 2003;9:290-7.

98. Larsen FS, Ejlersen E, Hansen BA, Mogensen T, Tygstrup N, Secher NH. Systemic vascular resistance during high-volume plasmapheresis in patients with fulminant hepatic failure: relationship with oxygen consumption. *European journal of gastroenterology & hepatology* 1995;7:887-92.

99. Larsen FS, Hansen BA, Ejlersen E, et al. Cerebral blood flow, oxygen metabolism and transcranial Doppler sonography during high-volume plasmapheresis in fulminant hepatic failure. *European journal of gastroenterology & hepatology* 1996;8:261-5.

100. Larsen FS, Schmidt LE, Bernsmeier C, et al. High-volume plasma exchange in patients with acute liver failure: an open randomised controlled trial. *Journal of Hepatology* 2016;64:69-78.

101. Thompson J, Jones N, Al-Khafaji A, et al. Extracorporeal cellular therapy (ELAD) in severe alcoholic hepatitis: a multinational, prospective, controlled, randomized trial. *Liver Transplantation* 2018;24:380-93.

## **CHAPTER 2—The Natural History of Acetaminophen-Induced Acute Liver Failure**

MacDonald AJ, Speiser JL, Ganger DR, Nilles KM, Orandi BJ, Larson AM, Lee WM, Karvellas CJ. Clinical and neurological outcomes in acetaminophen-induced acute liver failure: a twenty-one year multicenter cohort study. *Submitted to Clinical Gastroenterology and Hepatology (June 8, 2020). Under Review.*

## **2.1 Introduction**

Acetaminophen (APAP) is the most common cause of acute liver failure (ALF) in Europe and North America.<sup>7,23,27</sup> Injury and recovery follow a hyper-acute pattern, in which maximum hepatocyte destruction is complete by 72 hours following ingestion, often necessitating intensive care unit (ICU) admission.<sup>2,3</sup> Resulting intracranial hypertension (ICH) and multisystem organ failure are associated with substantial morbidity and mortality, with cerebral edema (CE) responsible for up to 25% of ALF deaths.<sup>5,6</sup> Management is largely supportive and aims to control or prevent CE, correct metabolic derangements, and maintain hemodynamic stability.<sup>23,102</sup> For those failing maximal medical therapy, liver transplantation (LT) may be required; however, severity of critical illness and presence of concomitant psychosocial factors may complicate listing decisions for LT.<sup>17,103,104</sup>

Outcomes over time have improved overall for ALF patients;<sup>17,27</sup> however, contributing factors for this warrant further exploration. *N*-acetylcysteine (NAC) administration is accepted to minimize APAP-related hepatotoxicity and may also improve outcomes in non-APAP ALF.<sup>34,105,106</sup> More recently, continuous renal replacement therapy (CRRT) has been demonstrated to improve 21-day transplant-free survival (TFS) in all-etiology ALF.<sup>56</sup> What is not clear is whether changes in psychological profile (intentional overdose vs. therapeutic misadventure, psychiatric comorbidity) have changed with time or impacted APAP-ALF outcomes.<sup>27-31,107</sup> Recent, multicenter epidemiologic studies evaluating changes in interventions, psychosocial profile, and clinical outcomes in the context of APAP-ALF are lacking.<sup>7,23,27</sup>

Analyzing prospectively collected APAP-ALF patient data from the multicenter United States Acute Liver Failure Study Group (US ALFSG) registry between 1998 and 2018, we evaluated clinical parameters, intensive care interventions, rates of LT, and TFS stratifying the patient cohort in two eras; (1998-2007 ~ early; 2008-2018 ~ recent). Our primary objectives were to test the following hypotheses in APAP-ALF:

1. TFS is significantly higher in the recent cohort compared to the early cohort.
2. ICH development and CE-related deaths are significantly lower in the recent cohort.
3. The impact of psychosocial profile on important clinical outcomes has not changed with time and may not factor into clinical decision-making or outcomes.

## ***2.2 Patients and Methods***

### ***2.2.1 Study Design***

We performed a retrospective cohort study of all APAP-ALF patients prospectively enrolled in the US ALFSG registry between January 1998 and December 2018 (n=1190). The study's protocol was approved by all respective institutional review boards/health research ethics boards at participating sites (tertiary liver transplantation referral centers) within the US ALFSG. Written informed consent was obtained from each participant/next of kin (in cases of hepatic encephalopathy (HE) at time of enrollment). All research procedures were conducted according to the principles of the 1975 Declaration of

Helsinki. Therapeutic interventions and monitoring were implemented according to participating institutional standards of care. Criteria for listing and performing liver transplantation were those utilized at participating centers.

### **2.2.2 Participants**

Inclusion criteria were as follows: (1) evidence of ALF according to the enrollment criteria of the US ALFSG (see operational definitions), (2) participant age  $\geq 18$  years, and (3) primary diagnosis of APAP-ALF as determined by the site investigator and further adjudicated by an external review committee. Exclusion criteria were as follows: (1) evidence of cirrhosis/acute-on-chronic liver failure and (2) non-APAP ALF etiology. No patients with severe acute liver injury were enrolled in this cohort study.<sup>108</sup>

### **2.2.3 Operational Definitions**

For the purpose of this study, ALF was defined using the following criteria: (1) international normalized ratio (INR)  $\geq 1.5$ , (2) HE of any grade (West Haven Criteria), (3) illness onset less than 26 weeks from hepatic insult, and (4) absence of existing cirrhosis. The King's College Criteria (KCC) qualify poor prognostic signs in ALF. In APAP-ALF, KCC is defined as either (1) arterial pH  $< 7.3$ , or (2) all three of i) INR  $> 6.5$ , ii) creatinine  $> 300$   $\mu\text{mol/L}$  (3.4 mg/dL), and iii) the presence of grade 3/4 HE. The Acute Liver Failure Study Group Prognostic Index (ALFSG-PI) is an internally-validated mathematical model that predicts 21-day TFS of patients with ALF using hospital admission data and has been previously

described.<sup>75</sup> The model for end stage liver disease (MELD) is calculated as follows:  $[3.78 \cdot \ln(\text{bilirubin in mg/dL}) + 11.2 \cdot \ln(\text{INR}) + 9.57 \cdot \ln(\text{creatinine in mg/dL}) + 6.43]$ ; a serum creatinine value of 354  $\mu\text{mol/L}$  (4 mg/dL) is substituted for dialyzed patients. RRT included both intermittent hemodialysis (IHD) and continuous hemofiltration (CRRT). Patients receiving CRRT and IHD during days 1-7 were coded accordingly. The use of RRT within the US ALFSG is not standardized; thus, modality, replacement fluid, anticoagulation, dose, and indications for initiation and cessation of therapy were based on intensivist judgement at the enrolling center. Development of ICH was defined as any recorded intracranial pressure (ICP) measurement  $\geq 25$  mmHg, computed tomography/magnetic resonance imaging findings consistent with CE, and/or neurologic cause of death within 21 days of enrollment. Overdose intent was classified based on patient self-reporting and chart review: *intentional* overdose was considered a single timepoint ingestion in a patient indicating suicidal intent; *unintentional* overdose was considered a multi-timepoint ingestion of excessive APAP quantities to relieve somatic symptoms with an absence of suicidal intent. Intentionality classified as “unknown” was excluded from analysis.

#### **2.2.4 Clinical Variables and Endpoints**

The US ALFSG registry (data coordinating center at Medical University of South Carolina, Department of Public Health Sciences, Charleston, South Carolina) contains prospectively collected demographic, clinical (days 1-7), biochemical (days 1-7), and outcome data. Data assessed in this study included baseline patient characteristics (age, sex, overdose intent, psychiatric comorbidities), requirement of organ support

(mechanical ventilation, vasopressors, RRT), early and late biochemistry profile (complete blood count, INR, transaminases, bilirubin, pH, ammonia, creatinine, lactate, phosphate), HE grade, NAC use, and clinical outcomes (LT listing, receipt of LT, 21-day TFS, and overall 21-day survival). The primary endpoint for this study was 21-day TFS. Participants were stratified into two enrollment time cohorts as follows: 1998-2007 (“early” cohort) and 2008-2018 (“recent” cohort).

### **2.2.5 Statistical Analysis**

Categorical variables were presented as proportions and compared using the Chi-squared test. Continuous variables were presented as medians with interquartile range (IQR) following assessment for normality using skewness ( $\pm 0.5$ ) and kurtosis ( $\pm 2$ ) and subsequently compared using the Mann-Whitney *U* test (all continuous variables were non-normally distributed). The study of associations with 21-day TFS was completed using logistic regression. Clinically relevant covariates or those yielding  $p < 0.10$  on univariate analysis were initially chosen for multivariable analysis including sex, age, HE grade, use of vasopressors, use of RRT, KCC classification, MELD, overdose intent, psychiatric history, and enrollment time cohort. Final models were derived using a backward elimination process with a p-value threshold of 0.05. Collinearity was assessed using matrix coefficients and avoided where appropriate. Model performance was assessed using area under the receiver operating curve (AUROC). All analyses were two-tailed. We used a threshold for statistical significance of 0.05. Statistical analysis was performed using Stata (version 15.1; StataCorp, College Station, Texas), SAS (version



9.4; SAS Institute, Cary, North Carolina), and R (version 0.99.879; RStudio, Boston, Massachusetts).

## **2.3 Results**

### **2.3.1 Baseline APAP-ALF Cohort Parameters**

A total of 1190 patients with ALF secondary to APAP toxicity were identified within the US ALFSG data registry between January 1998 and December 2018. Median (IQR) age was 37 (28-47) years and 895 (75.2%) patients were female. During the first seven days of inpatient study, 733 (63.3%) patients developed grade 3/4 HE, and 216 (18.2%) patients met APAP-specific KCC for consideration of LT listing. Mechanical ventilation, vasopressor therapy, and CRRT were required in 735 (61.8%), 394 (33.1%), and 179 (15.0%) patients, respectively. When overdose intention was known (n=1062), 445 patients (41.9%) presented with intentional overdose. Pre-existing psychiatric diagnoses were present in 641 patients (53.9%). Median (IQR) admission ALFSG-PI predicted probability of TFS was 74.1% (49.5%-86.8%). Demographic and clinical outcomes of the APAP-ALF cohort are described in Table 2.1.

### **2.3.2 Univariate Analysis of APAP-ALF Patients: Enrollment Time Cohort**

Comparisons of enrollment time cohort (recent: 2008-2018 vs. early: 1998-2007) demographic and clinical outcome parameters are shown in Table 2.2. During the first

seven days of inpatient study, there were no significant differences comparing recent and early cohorts in terms of meeting KCC (17.4% vs. 18.9%;  $p=0.51$ ), having grade 3/4 HE (62.0% vs. 64.5%;  $p=0.38$ ), and requiring mechanical ventilation (59.9% vs. 63.7%;  $p=0.17$ ) or vasopressors (30.8% vs. 35.6%;  $p=0.08$ ). Comparing the admission ALFSG-PI for the recent vs. early cohorts, there were no significant differences in median predicted probability of TFS (72.7% vs. 74.8%;  $p=0.83$ ) or proportion reaching the optimal survival probability prediction threshold of 80% (40.1% vs. 37.8%;  $p=0.43$ ). Recent time cohort patients were more likely to receive CRRT (22.2% vs. 7.6%) and were less likely to receive IHD (14.4% vs. 31.0%,  $p<0.001$  for all). *Recent time cohort patients demonstrated significantly higher 21-day TFS (69.8% vs. 61.7%), and lower rates of ICH (29.9% vs. 51.5%) and 21-day CE-related death (4.5% vs. 11.6%;  $p<0.006$  for all).*

### **2.3.3 Univariate Analysis of Admission (Day 1) Parameters: Enrollment Time Cohort**

Comparisons of biochemical and clinical admission parameters by enrollment time cohort are shown in Table 2.3. Comparing recent vs. early cohorts on admission, there were no significant differences in patients meeting KCC (11.7% vs. 13.2%;  $p=0.42$ ), having high grade (3/4) HE (52.5% vs. 51.5%;  $p=0.71$ ), and requiring mechanical ventilation (52.8% vs. 53.3%;  $p=0.87$ ), or vasopressor support (23.7% vs. 22.3%;  $p=0.58$ ). *Significantly more patients were treated with CRRT on admission in the recent cohort over early cohort (15.8% vs. 4.1%;  $p<0.001$ ).*

### **2.3.4 Univariate Analysis of APAP-ALF Patients: 21-day Transplant-free Survival**

In comparing subjects who were alive at day 21 without LT (TFS) with those that either were transplanted or died (non-TFS), there were no significant differences in pre-existing psychiatric comorbidity (51.5% vs. 55.0%;  $p=0.28$ ) and intentional overdose (39.7% vs. 41.6%;  $p=0.58$ ). On admission, non-TFS patients had worse biochemical profiles and required greater organ support. By day 21, non-TFS patients displayed greater incidence of ICH and, among 273 deceased patients, 83 of 271 known causes of death (30.6%) were secondary to CE. Comparisons of non-TFS and TFS patients on admission and at day 21 are shown in Table 2.4 and Table 2.5.

### **2.3.5 Multivariable Analysis: Associations with TFS**

Multivariable logistic regression was performed to determine associations with 21-day TFS (Table 2.6 and Figure 2.1). Two models utilizing the same covariates were developed based on univariate logistic regression and previous publications.<sup>56,109</sup> Sex, overdose intent, and presence of pre-existing psychiatric comorbidity were not significantly associated with 21-day TFS on univariate analysis. To analyze CRRT and enrollment cohort separately (collinearity), we developed two models. *Model 1* included use of CRRT, while *Model 2* included enrollment time cohort. Adjustment for participant age was retained in both models due to clinical significance.

In *Model 1*, the following covariates (over days 1-7) were significantly associated with 21-day TFS; vasopressor support (OR: 0.25; 95% CI: 0.17-0.35;  $p<0.001$ ),

development of grade 3/4 HE (OR 0.21; 95% CI: 0.13-0.33;  $p < 0.001$ ), fulfillment of KCC (OR 0.53; 95% CI: 0.36-0.78;  $p = 0.001$ ), MELD (per unit increase: OR 0.92; 95% CI: 0.90-0.94;  $p < 0.001$ ) and the use of CRRT (OR 1.62; 95% CI: 1.07-2.44;  $p = 0.023$ ), but not age (per unit increase: OR 0.99; 95% CI: 0.98-1.00;  $p = 0.10$ ). This model had AUROC of 0.86.

In *Model 2*, the following covariates were significantly associated with 21-day TFS; vasopressor support (OR 0.28; 95% CI: 0.20-0.39;  $p < 0.001$ ), grade 3/4 HE (OR 0.21; 95% CI: 0.13-0.33;  $p < 0.001$ ), KCC (OR 0.53; 95% CI: 0.36-0.79;  $p = 0.021$ ), MELD (per unit increase: OR 0.92; 95% CI: 0.90-0.94;  $p < 0.001$ ), and enrollment time cohort (for 2008-2018: OR 1.42; 95% CI: 1.03-1.97;  $p = 0.034$ ), but not age (per unit increase: OR 0.99; 95% CI: 0.98-1.00;  $p = 0.06$ ). This model also had AUROC of 0.86.

## **2.4 Discussion**

### **2.4.1 Key Results**

Outcomes in APAP-ALF within the US ALFSG have significantly improved over the last 21 years, with 21-day TFS significantly increasing more than 8 percent, from 61.7% during 1998-2007 to 69.8% during 2008-2018. Incidence of ICH and 21-day mortality secondary to CE have significantly decreased, from 51.5% to 29.9% and from 11.6% to 4.5%, respectively, between the same time periods. After adjusting for covariates reflecting severity of illness (vasopressor use, high coma grade, KCC, and MELD), both the use of CRRT and recent enrollment cohort were significantly associated with improved 21-day TFS. Between 1998-2007 and 2008-2018, use of CRRT significantly

increased (7.6% to 22.2% during first 7 days). Overdose intent, and presence of pre-existing psychiatric comorbidity were not associated with 21-day TFS.

#### **2.4.2 Comparison with the Literature**

In this study, 21-day TFS significantly improved over time without a change in the rate of LT. Admission ALFSG-PI that predicted the probability of TFS did not differ across enrollment time cohorts, suggesting the protective role of one or more post-admission factors associated with recent enrollment. Bernal et al., in a large single center cohort (*Kings College Hospital's*) 33-year experience with 3300 all-etiology ALF patients, noted a progressive rise in all-etiology TFS from 17% in 1973-1978 to 48% in 2004-2008, with 25.4% of the APAP-ALF cohort undergoing emergent LT.<sup>23</sup> This may reflect improved care in a highly specialized liver critical care/transplant center with evolving intensive care strategies.<sup>7,23</sup>

Cerebral edema/herniation is a well described complication of APAP-ALF.<sup>110</sup> Both 21-day ICH development and CE-related death significantly decreased between the 1998-2007 and 2008-2018 enrollment cohorts from 51.5% to 29.9% and 11.6% to 4.5%, respectively. These APAP-ALF-specific findings echo those of serial all-etiology ALF Japanese studies where development of CE declined from 35.3% in 1998-2003 to 24.1% in 2004-2009.<sup>111,112</sup> Similarly, Bernal et al also demonstrated a significant decline in ICH incidence from 76% in 1984-1988 to 19.8% in 2004-2008 in all-etiology ALF, with ICH-associated mortality significantly decreasing from 95% in 1973-1978 to 55% in 2003-2008.<sup>23</sup>

Explaining the observed reductions in incidence of ICH/CE-death is speculative. In this study, serum ammonia levels on admission were not statistically different, and similar proportions developed high grade HE, and required mechanical ventilation or vasopressor support across enrollment cohorts. Equivalent/reduced use of ICP monitoring, ICP-lowering therapies (apart from increased use of hypothermia), and NAC administration were observed during the recent time period since NAC use depends on early recognition of APAP injury, but is often applied too late in those with severe liver injury upon arrival. Notably, recent time cohort patients were significantly more likely to receive CRRT on admission (15.8% vs. 4.1%) and over days 1-7 (22.2% vs. 7.6%), while early enrollment cohort patients were significantly more likely to receive IHD over days 1-7 (31.0% vs. 14.4%).

High serum ammonia levels are believed to play a role in the pathogenesis of CE and are associated with worsening HE and ICH.<sup>55,113,114</sup> In 2014, Slack and colleagues first described the use of CRRT with hemofiltration to achieve a statistically significant reduction of ammonia clearance in ALF and in acute-on-chronic liver failure patients that correlated with the dose of ultrafiltration employed.<sup>58</sup> In evaluating the role of RRT in all-etiology ALF, Cardoso et al reported statistically significant ammonia clearance with CRRT, but not with IHD. An improvement in 21-day TFS was associated with CRRT. Conversely, IHD was associated with a decrease in 21-day TFS.<sup>56</sup> Most recently, Warrillow et al demonstrated in 54 ALF patients in Australia who underwent CRRT (continuous venovenous hemofiltration, median time to initiation ~ 4 hours) that CRRT was associated with significant reduced ammonia concentrations in ALF patients with its effect proportionate to cumulative dose.<sup>59</sup>

Unlike CRRT, IHD has previously been shown to be associated with significant increases in ICP, and significant decreases in mean arterial pressure and cardiac index.<sup>71</sup> High blood flow rates, swings in hemodynamic stability, and rapid osmotic shifts associated with IHD reduce cerebral perfusion pressure and may induce or exacerbate CE.<sup>56,71</sup> After adjusting for significant covariates reflecting likelihood of TFS, we have shown that CRRT is associated with improved 21-day TFS in APAP-ALF. In ALF patients at high risk of ICH and CE (i.e. ventilated, encephalopathic patients with hemodynamic instability, acute renal injury etc.), CRRT is seen as a safer modality, as it minimizes sudden shifts in serum osmolality and cerebral perfusion pressure, and offers additional neuroprotective cooling, while normalizing metabolic parameters and hyperammonemia.<sup>14,23,115,116</sup>

Finally, we did not find an association between psychosocial profile and 21-day TFS in APAP-ALF. No differences in overdose intentionality and presence of pre-existing psychiatric diagnosis were observed between 21-day TFS and non-TFS patients. Furthermore, there were no differences in rates of intentional overdose vs. therapeutic misadventure between the two time cohorts. Listing for LT among APAP patients does not appear to be impacted by psychiatric history.<sup>107</sup> Recurrent suicidality and poorer compliance with pharmacotherapy and follow-up have been highlighted as potential problems in post-LT APAP-ALF patients;<sup>73</sup> however, APAP-ALF patients have been reported to display similar long-term outcomes post-LT to those of non-APAP ALF patients.<sup>72,103</sup>

### **2.4.3 Strengths and Limitations**

This study should be interpreted in light of its strengths and limitations. The strengths consist of inclusion of APAP-ALF patients from multiple intensive care units across several geographic regions in North America. Patients in this study were largely young, female, and had similar demographics to those reported in other ALF studies from both Europe and North America.<sup>49</sup> Therefore, the results of this study appear to have reasonable generalizability. Regarding its limitations, this retrospective analysis of prospectively collected observational data may comment only on association; we are unable to conclusively exclude sources of selection bias.<sup>117</sup> Diagnosis of ICH was established retrospectively and dependent on the availability of ICP measurements, imaging features, and/or recorded cause of death. Data confirming the presence or absence of ICH was available in 577 of 1190 patients (48.5%), with greater availability in recent period over early period patients (66.8% vs. 28.4%). Clinically, while patients without any of the aforementioned data sources were plausibly less likely to have had ICH, the impact of missing data should be considered. Despite these limitations, this study represents the most recent and largest cohort of consecutive APAP-ALF patients evaluating clinical and neurological outcome trends over the last 21 years across multiple tertiary care centers leading to broad generalizability of the results.



## **2.5 Conclusions**

In patients with APAP-ALF, TFS has significantly improved with time, along with a significant decline in the incidence of ICH and CE-related death. These findings have occurred in association with increased early CRRT (and decreased IHD) use within the intensive care setting possibly reflecting improvements in ICU management. Psychiatric comorbidities and overdose intent do not appear to be significantly associated with likelihood of TFS in APAP ALF.

**Table 2.1.** Demographic, clinical, and outcome parameters in APAP-ALF patient cohort.

Parameter	Overall (N = 1190)	
	N	
<b>Age (years)</b>	1190	37 (28-47)
<b>Sex (male)</b>	1190	295 (24.8%)
<b>King's College Criteria met (days 1-7)</b>	1190	216 (18.2%)
<b>ALFSG Prognostic Index (admission)</b>		
Predicted Probability (%)	1104	74.1 (49.5-86.8)
Predicted Probability $\geq$ 80%	1104	430 (38.9%)
<b>Highest MELD (median; days 1-7)</b>	1176	27.5 (17.9-34.0)
<b>Coma Grade 3/4 (days 1-7)</b>	1158	733 (63.3%)
<b>Organ Support (days 1-7)</b>		
Mechanical Ventilation	1190	735 (61.8%)
Vasopressors	1190	394 (33.1%)
Continuous Renal Replacement Therapy	1190	179 (15.0%)
<b>ICP Directed Therapies (days 1-7)</b>		
ICP monitor	1190	144 (12.1%)
Mannitol	1190	230 (19.3%)
Barbiturate	1190	81 (6.8%)
Hypothermia	1190	73 (6.1%)
Sedatives	1190	740 (62.2%)
<b>Blood Products (days 1-7)</b>		
Red Blood Cells	1190	354 (29.7%)
Fresh Frozen Plasma	1190	539 (45.3%)
Recombinant Factor VIIA	1190	21 (1.8%)
Platelets	1190	224 (18.8%)
<b>ICU Complications (days 1-7)</b>		
Seizures	1190	73 (6.1%)
Arrhythmia	1190	247 (20.8%)
Gastrointestinal Bleeding	1190	101 (8.5%)
<b>N-acetylcysteine<sup>a</sup></b>		
Intravenous	1190	984 (82.7%)
Oral	1190	754 (63.4%)
<b>Psychological Comorbidities</b>	1190	641 (53.9%)
Depression	983	434 (44.2%)
Schizophrenia	565	16 (2.8%)
Chronic Pain	553	4 (0.7%)
Bipolar Disorder	664	115 (17.3%)
Anxiety	679	130 (19.1%)
<b>Overdose Intent<sup>b</sup></b>		
Intentional	1062	445 (41.9%)
Unintentional	1062	617 (58.1%)
<b>Intravenous Drug Use</b>	1178	95 (8.1%)
<b>Intracranial Hypertension (days 1-21)</b>	577	208 (36.0%)

<b>Death (days 1-21)</b>	1048	273 (26.0%)
Cerebral Edema Death	1046	83 (7.9%)
<b>Listed for Liver Transplantation</b>	1189	273 (23.0%)
<b>Received Liver Transplant (days 1-21)</b>	1186	100 (8.4%)
<b>Transplant-free Survival (day 21)</b>	1069	704 (65.9%)

<sup>a</sup> *Some subjects received both intravenous and oral N-acetylcysteine*

<sup>b</sup> *Overdose intent could not be determined (i.e., unknown) in 128 subjects*

Abbreviations: *ALFSG*, Acute Liver Failure Study Group; *ICP*, intracranial pressure; ICU, intensive care unit; *MELD*, model for end stage liver disease.

**Table 2.2.** Patient parameters stratified by time cohort (1998-2007 vs. 2008-2018).

	“Early” (1998-2007) (N = 582)		“Recent” (2008-2018) (N = 608)		P- value
	N		N		
<b>Age (years)</b>	582	36 (28-45)	608	37 (28-49)	0.026
<b>Sex (male)</b>	582	147 (25.3%)	608	148 (24.3%)	0.72
<b>King’s College Criteria met (days 1-7)</b>	582	110 (18.9%)	608	106 (17.4%)	0.51
<b>ALFSG Prognostic Index (admission)</b>					
Survival Predicted Probability $\geq$ 80%	566	214 (37.8%)	538	216 (40.1%)	0.43
<b>Highest MELD (days 1-7)</b>	576	29.0 (18.7-35.7)	600	25.8 (16.3-32.5)	<0.001
<b>Coma Grade 3/4 (days 1-7)</b>	581	375 (64.5%)	577	358 (62.0%)	0.38
<b>Organ Support (days 1-7)</b>					
Mechanical Ventilation	582	371 (63.7%)	608	364 (59.9%)	0.17
Vasopressors	582	207 (35.6%)	608	187 (30.8%)	0.08
Continuous Renal Replacement Therapy	582	44 (7.6%)	608	135 (22.2%)	<0.001
Intermittent Hemodialysis	577	179 (31.0%)	604	87 (14.4%)	<0.001
<b>ICP Directed Therapies (days 1-7)</b>					
ICP monitor	582	95 (16.3%)	608	49 (8.1%)	<0.001
Mannitol	582	125 (21.5%)	608	105 (17.3%)	0.07
Barbiturate	582	59 (10.1%)	608	22 (3.6%)	<0.001
Hypothermia	582	18 (3.1%)	608	55 (9.0%)	<0.001
Sedatives	582	398 (68.4%)	608	342 (56.2%)	<0.001
<b>Blood Products (days 1-7)</b>					
Red Blood Cells	582	225 (38.7%)	608	129 (21.2%)	<0.001
Fresh Frozen Plasma	582	341 (58.6%)	608	198 (32.6%)	<0.001
Recombinant Factor VIIA	582	0 (0.0%)	608	21 (3.5%)	<0.001
Platelets	582	123 (21.1%)	608	101 (16.6%)	0.046
<b>ICU Complications (days 1-7)</b>					
Seizures	582	46 (7.9%)	608	27 (4.4%)	0.013
Arrhythmia	582	159 (27.3%)	608	88 (14.5%)	<0.001
Gastrointestinal Bleeding	582	68 (11.7%)	608	33 (5.4%)	<0.001
<b>N-acetylcysteine</b>					
Intravenous	582	504 (86.6%)	608	480 (78.9%)	<0.001
Oral	582	516 (88.7%)	608	238 (39.1%)	<0.001
<b>Psychological Comorbidities</b>	582	286 (49.1%)	608	355 (58.4%)	0.001
Depression	497	201 (40.4%)	486	233 (47.9%)	0.018
Schizophrenia	300	4 (1.3%)	265	12 (4.5%)	0.022

Chronic Pain	299	3 (1.0%)	254	1 (0.4%)	0.40
Bipolar Disorder	333	37 (11.1%)	331	78 (23.6%)	<0.001
Anxiety	332	36 (10.8%)	347	94 (27.1%)	<0.001
<b>Overdose Intent</b>					0.12
Intentional	526	233 (44.3%)	536	212 (39.6%)	
Unintentional	526	293 (55.7%)	536	324 (60.4%)	
<b>Intravenous Drug Use</b>	572	31 (5.4%)	606	64 (10.6%)	0.001
<b>Intracranial Hypertension (days 1-21)</b>	165	85 (51.5%)	412	123 (29.9%)	<0.001
<b>Death (days 1-21)</b>	509	156 (30.6%)	539	117 (21.7%)	0.001
Cerebral Edema Death	509	59 (11.6%)	537	24 (4.5%)	<0.001
<b>Listed for Liver Transplantation</b>	582	152 (26.1%)	607	121 (19.9%)	0.011
<b>Received Liver Transplant (days 1-21)</b>	581	50 (8.6%)	605	50 (8.3%)	0.83
<b>Transplant-free Survival (day 21)</b>	519	320 (61.7%)	550	384 (69.8%)	0.005

Abbreviations: *ALFSG*, Acute Liver Failure Study Group; *ICP*, intracranial pressure; ICU, intensive care unit; *MELD*, model for endstage liver disease.

**Table 2.3.** Biochemical and organ support parameters at admission, stratified by time cohort (1998-2007 vs. 2008-2018).

			<b>“Early” (1998-2007) (N = 582)</b>	<b>“Recent” (2008-2018) (N = 608)</b>	<b>P- value</b>	
<b>Biochemistry</b>						
Hemoglobin (g/L)		578	111 (96-128)	579	106 (93-121)	<0.001
White Blood Cells (10 <sup>9</sup> /L)		579	9.4 (6.3-14.1)	599	9.3 (6.3-13.5)	0.41
Platelets (10 <sup>9</sup> /L)		579	126 (84-179)	592	125.5 (81.5-181)	0.71
INR		570	2.8 (2.0-4.6)	590	3.05 (2.1-4.4)	0.37
AST (IU/L)		579	4110 (1543-8160)	594	3093 (1374-6981)	0.004
ALT (IU/L)		578	4024 (2121-6702)	595	3543 (1916-5733)	0.005
Bilirubin	(µmol/L)	579	78.7 (49.6-112.9)	589	71.8 (42.8-107.7)	0.037
	(mg/dL)		4.6 (2.9-6.6)		4.2 (2.5-6.3)	
pH		527	7.42 (7.36-7.48)	468	7.41 (7.34-7.46)	0.002
Ammonia (venous) (µmol/L)		170	110.5 (70-159)	288	97 (68-168)	0.94
Creatinine	(µmol/L)	581	168.0 (88.4-309.4)	602	141.4 (76.0-260.8)	<0.001
	(mg/dL)		1.9 (1.0-3.5)		1.6 (0.86-2.95)	
Lactate (mmol/L)		345	4.9 (2.7-9.3)	410	3.3 (2.1-6.78)	<0.001
Phosphate (mmol/L)		513	0.81 (0.52-1.26)	520	0.81 (0.58-1.15)	0.47
<b>King’s College Criteria met</b>		582	77 (13.2%)	608	71 (11.7%)	0.42
<b>ALFSG Prognostic Index</b>						
Survival Predicted Probability ≥ 80%		566	214 (37.8%)	538	216 (40.1%)	0.43
<b>MELD</b>		566	31.4 (22.8-38.7)	574	29.6 (21.0-36.7)	0.005
<b>Coma Grade 3/4</b>		581	299 (51.5%)	569	299 (52.5%)	0.71
<b>Organ support</b>						
Mechanical Ventilation		582	310 (53.3%)	608	321 (52.8%)	0.87
Vasopressors		582	130 (22.3%)	608	144 (23.7%)	0.58
Continuous Renal Replacement Therapy		581	24 (4.1%)	608	96 (15.8%)	<0.001

Abbreviations: *ALFSG*, Acute Liver Failure Study Group; *ALT*, alanine aminotransferase; *AST*, aspartate aminotransferase; *INR*, international normalized ratio, *MELD*, model for endstage liver disease.

**Table 2.4.** Patient parameters stratified by spontaneous survival at day 21 (deceased/transplanted vs. transplant-free survivors).

	<b>Deceased/Transplanted (N = 365)</b>		<b>Transplant-free Survivors (N = 704)</b>		<b>P- value</b>
	<b>N</b>		<b>N</b>		
<b>Age (years)</b>	365	38 (28-47)	704	36 (28-46)	0.06
<b>Sex (male)</b>	365	88 (24.1%)	704	180 (25.6%)	0.60
<b>King's College Criteria (days 1-7)</b>	365	128 (35.1%)	704	78 (11.1%)	<0.001
<b>ALFSG Prognostic Index (admission)</b>					
Survival Predicted Probability ≥ 80%	342	36 (10.5%)	649	331 (51.0%)	<0.001
<b>Highest MELD (days 1-7)</b>	357	33.7 (28.2-38.8)	701	24.0 (14.1-31.0)	<0.001
<b>Coma Grade 3/4 (days 1-7)</b>	353	323 (91.5%)	685	361 (52.7%)	<0.001
<b>Organ Support (days 1-7)</b>					
Mechanical Ventilation	365	331 (90.7%)	704	361 (51.3%)	<0.001
Vasopressors	365	240 (65.8%)	704	137 (19.5%)	<0.001
Continuous Renal Replacement Therapy	365	78 (21.4%)	704	96 (13.6%)	0.001
<b>ICP Directed Therapies (days 1-7)</b>					
ICP monitor	365	82 (22.5%)	704	55 (7.8%)	<0.001
Mannitol	365	123 (33.7%)	704	94 (13.4%)	<0.001
Barbiturate	365	49 (13.4%)	704	27 (3.8%)	<0.001
Hypothermia	365	32 (8.8%)	704	36 (5.1%)	0.020
Sedatives	365	282 (77.3%)	704	406 (57.7%)	<0.001
<b>Blood Products (days 1-7)</b>					
Red Blood Cells	365	163 (44.7%)	704	165 (23.4%)	<0.001
Fresh Frozen Plasma	365	253 (69.3%)	704	245 (34.8%)	<0.001
Recombinant Factor VIIA	365	13 (3.6%)	704	8 (1.1%)	0.007
Platelets	365	125 (34.2%)	704	87 (12.4%)	<0.001
<b>ICU Complications (days 1- 7)</b>					
Seizures	365	47 (12.9%)	704	24 (3.4%)	<0.001



Arrhythmia	365	109 (29.9%)	704	126 (17.9%)	<0.001
Gastrointestinal Bleeding	365	53 (14.5%)	704	41 (5.8%)	<0.001
<b>N-acetylcysteine</b>					
Intravenous	365	299 (81.9%)	704	583 (82.8%)	0.72
Oral	365	236 (64.7%)	704	426 (60.5%)	0.19
<b>Psychological Comorbidities</b>	365	188 (51.5%)	704	387 (55.0%)	0.28
Depression	307	130 (42.3%)	576	259 (45.0%)	0.46
Schizophrenia	182	5 (2.7%)	325	8 (2.5%)	0.85
Chronic Pain	178	1 (0.6%)	318	1 (0.3%)	0.68
Bipolar Disorder	202	25 (12.4%)	391	74 (18.9%)	0.043
Anxiety	212	35 (16.5%)	400	83 (20.8%)	0.21
<b>Overdose Intent</b>					0.58
Intentional	317	126 (39.7%)	639	266 (41.6%)	
Unintentional	317	191 (60.2%)	639	373 (58.4%)	
<b>Intravenous Drug Use</b>	359	23 (6.4%)	699	69 (9.9%)	0.06
<b>Intracranial Hypertension (days 1-21)</b>	215	132 (61.4%)	321	71 (22.1%)	<0.001
<b>Death (days 1-21)</b>	342	273 (79.8%)	704	0 (0.0%)	<0.001
Cerebral Edema Death	340	83 (24.4%)	704	0 (0.0%)	<0.001
<b>Listed for Liver Transplantation</b>	365	157 (43.0%)	704	92 (13.1%)	<0.001
<b>Received Liver Transplant (days 1-21)</b>	364	100 (27.5%)	704	0 (0.0%)	<0.001

Abbreviations: *ALFSG*, Acute Liver Failure Study Group; *ICP*, intracranial pressure; ICU, intensive care unit; *MELD*, model for endstage liver disease.

**Table 2.5.** Biochemical and organ support parameters at admission, stratified by spontaneous survival at day 21 (died/transplanted vs. transplant-free survivors).

		Deceased/Transplanted (N = 365)		Transplant-free Survivors (N = 704)		P-value
Biochemistry		N		N		
Hemoglobin (g/L)		362	103 (91-121)	695	111 (95-127)	<0.001
White Blood Cells (10 <sup>9</sup> /L)		362	11.0 (6.8-16.1)	695	8.8 (6.2-12.8)	<0.001
Platelets (10 <sup>9</sup> /L)		362	112 (68-166)	689	131 (91-184)	<0.001
INR		356	3.6 (2.4-5.6)	688	2.7 (1.9-4.0)	<0.001
AST (IU/L)		362	5311 (2357-9301)	693	2852 (1160-6660)	<0.001
ALT (IU/L)		361	4100 (1965-6534)	693	3543 (2031-5867)	0.09
Bilirubin	(µmol/L)	362	83.8 (59.9-121.4)	687	70.1 (41.0-104.3)	<0.001
	(mg/dL)		4.9 (3.5-7.1)		4.1 (2.4-6.1)	
pH		336	7.40 (7.32-7.47)	563	7.42 (7.36-7.47)	<0.001
Ammonia (venous) (µmol/L)		138	148 (102-258)	273	89 (61-134)	<0.001
Creatinine	(µmol/L)	365	212.2 (123.8-309.4)	697	123.8 (70.7-256.4)	<0.001
	(mg/dL)		2.4 (1.4-3.5)		1.4 (0.8-2.9)	
Lactate (mmol/L)		253	7.8 (4.7-12.8)	428	2.9 (1.8-5.0)	<0.001
Phosphate (µmol/L)		311	1.06 (0.68-1.52)	616	0.74 (0.52-1.07)	<0.001
<b>King's College Criteria met</b>		365	83 (22.7%)	704	59 (8.4%)	<0.001
<b>ALFSG Prognostic Index</b>						
Survival Predicted Probability ≥ 80%		342	36 (10.5%)	649	331 (51.0%)	<0.001
<b>MELD</b>		353	36.0 (29.2-41.6)	673	27.3 (18.9-35.1)	<0.001
<b>Coma Grade 3/4</b>		353	259 (73.4%)	677	301 (44.5%)	<0.001
<b>Organ support</b>						
Mechanical Ventilation		365	283 (77.5%)	704	313 (44.5%)	<0.001
Vasopressors		365	172 (47.1%)	704	91 (12.9%)	<0.001
Continuous Renal Replacement Therapy		364	50 (13.7%)	704	66 (9.4%)	0.030

Abbreviations: *ALFSG*, Acute Liver Failure Study Group; *ALT*, alanine aminotransferase; *AST*, aspartate aminotransferase; *INR*, international normalized ratio, *MELD*, model for endstage liver disease.

**Table 2.6.** Predictors of 21-day transplant-free survival in APAP-ALF patients.

Variable	Univariate			
	N	OR	95% OR CI	P-value
Sex <sup>a</sup>	1069	0.92	(0.69, 1.24)	0.60
Age	1069	0.99	(0.98, 1.00)	0.046
Vasopressors (days 1-7)	1069	0.13	(0.09, 0.17)	<0.001
CRRT (days 1-7)	1069	0.58	(0.42, 0.81)	0.001
Grade 3/4 Coma (days 1-7)	1038	0.10	(0.07, 0.15)	<0.001
King's College Criteria (days 1-7)	1069	0.23	(0.17, 0.32)	<0.001
Highest MELD Score (days 1-7)	1058	0.91	(0.89, 0.92)	<0.001
Overdose Intent <sup>b</sup>	956	1.08	(0.82, 1.42)	0.58
Psych Comorbidity	1069	1.15	(0.89, 1.48)	0.28
Time Cohort <sup>c</sup>	1069	1.44	(1.12, 1.85)	0.005
<b>Multivariate Model 1</b>				
<b>N = 1028 AUROC = 0.86</b>				
Variable	Included in Model	aOR	95% aOR CI	P-value
Sex <sup>a</sup>	No	--	--	--
Age	Yes	0.99	(0.98, 1.00)	0.10
Vasopressors (days 1-7)	Yes	0.25	(0.17, 0.35)	<0.001
CRRT (days 1-7)	Yes	1.62	(1.07, 2.44)	0.023
Grade 3/4 Coma (days 1-7)	Yes	0.21	(0.13, 0.33)	<0.001
King's College Criteria (days 1-7)	Yes	0.53	(0.36, 0.78)	0.001
Highest MELD Score (days 1-7)	Yes	0.92	(0.90, 0.94)	<0.001
Overdose Intent <sup>b</sup>	No	--	--	--
Psych Comorbidity	No	--	--	--
Time Cohort <sup>c</sup>	No <sup>d</sup>	--	--	--
<b>Multivariate Model 2</b>				
<b>N = 1028 AUROC = 0.86</b>				
Variable	Included in Model	aOR	95% aOR CI	P-value
Sex <sup>a</sup>	No	--	--	--
Age	Yes	0.99	(0.98, 1.00)	0.06
Vasopressors (days 1-7)	Yes	0.28	(0.20, 0.39)	<0.001
CRRT (days 1-7)	No <sup>d</sup>	--	--	--
Grade 3/4 Coma (days 1-7)	Yes	0.21	(0.13, 0.33)	<0.001
King's College Criteria (days 1-7)	Yes	0.53	(0.36, 0.79)	0.002
Highest MELD Score (days 1-7)	Yes	0.92	(0.90, 0.94)	<0.001
Overdose Intent <sup>b</sup>	No	--	--	--
Psych Comorbidity	No	--	--	--
Time Cohort <sup>c</sup>	Yes	1.42	(1.03, 1.97)	0.034

<sup>a</sup> Reference group: male sex

<sup>b</sup> *Reference group: unintentional overdose*

<sup>c</sup> *Reference group: 1998-2007 enrollment cohort*

<sup>d</sup> *Use of CRRT (Model 1) and enrollment time cohort (Model 2) were evaluated in separate models.*

Abbreviations: aOR, adjusted odds ratio; AUROC, area under receiver operator curve; CI, confidence interval; CRRT, continuous renal replacement therapy; *MELD*, model for endstage liver disease.

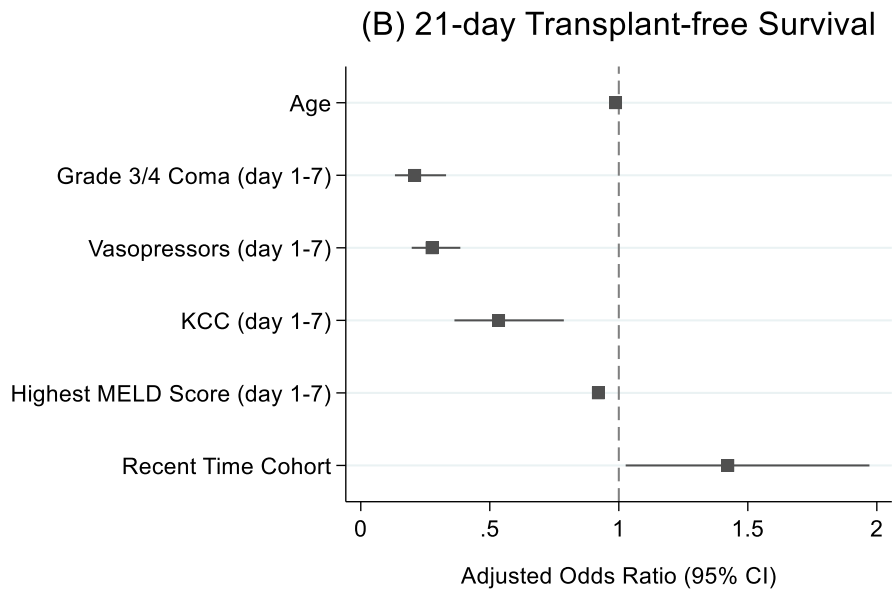
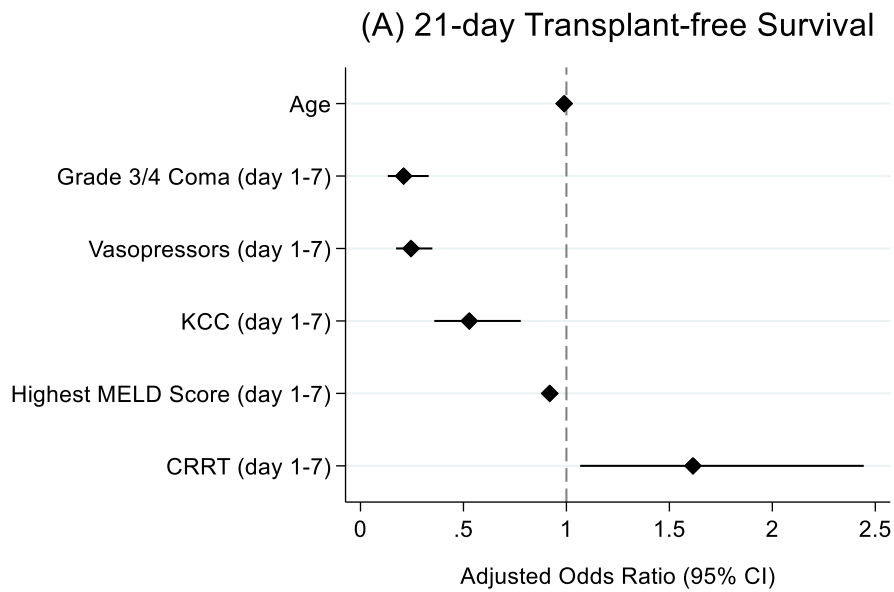

**Figure 2.1.** Adjusted associations with 21-day transplant-free survival in 1190 APAP-ALF patients. (A) Model 1 and (B) Model 2.

Abbreviations: CRRT, continuous renal replacement therapy; *CI*, confidence interval; *KCC*, King's College Criteria; *MELD*, model for endstage liver disease.

## **2.6 References**

2. O'Grady JG, Williams R. Classification of acute liver failure. *Lancet* 1993;342:743.
3. Bernal W, Wendon J. Acute liver failure. *N Engl J Med* 2013;369:2525-34.
5. Ware AJ, D'Agostino AN, Combes B. Cerebral edema: a major complication of massive hepatic necrosis. *Gastroenterology* 1971;61:877-84.
6. Bernal W, Wendon J. Acute liver failure; clinical features and management. *Eur J Gastroenterol Hepatol* 1999;11:977-84.
7. Reuben A, Tillman H, Fontana RJ, et al. Outcomes in adults with acute liver failure between 1998 and 2013: an observational cohort study. *Ann Intern Med* 2016;164:724-32.
14. Wendon J, Cordoba J, Dhawan A, et al. EASL clinical practical guidelines on the management of acute (fulminant) liver failure. *J Hepatol* 2017;66:1047-81.
17. Ostapowicz G, Fontana RJ, Schiodt FV, et al. Results of a prospective study of acute liver failure at 17 tertiary care centers in the United States. *Ann Intern Med* 2002;137:947-54.
23. Bernal W, Hyyrylainen A, Gera A, et al. Lessons from look-back in acute liver failure? A single centre experience of 3300 patients. *J Hepatol* 2013;59:74-80.
27. Larson AM, Polson J, Fontana RJ, et al. Acetaminophen-induced acute liver failure: results of a United States multicenter, prospective study. *Hepatology* 2005;42:1364-72.

28. Zimmerman HJ, Maddrey WC. Acetaminophen (paracetamol) hepatotoxicity with regular intake of alcohol: analysis of instances of therapeutic misadventure. *Hepatology* 1995;22:767-73.
29. Maddrey WC. Hepatic effects of acetaminophen. Enhanced toxicity in alcoholics. *J Clin Gastroenterol* 1987;9:180-5.
30. Whitcomb DC, Block GD. Association of acetaminophen hepatotoxicity with fasting and ethanol use. *JAMA* 1994;272:1845-50.
31. Schiodt FV, Rochling FA, Casey DL, Lee WM. Acetaminophen toxicity in an urban county hospital. *N Engl J Med* 1997;337:1112-7.
34. Lee WM, Hynan LS, Rossaro L, et al. Intravenous N-acetylcysteine improves transplant-free survival in early stage non-acetaminophen acute liver failure. *Gastroenterology* 2009;137:856-64, 64 e1.
49. Karvellas CJ, Todd Stravitz R, Battenhouse H, Lee WM, Schilsky ML, US Acute Liver Failure Study Group. Therapeutic hypothermia in acute liver failure: a multicenter retrospective cohort analysis. *Liver Transpl* 2015;21:4-12.
55. Bernal W, Hall C, Karvellas CJ, Auzinger G, Sizer E, Wendon J. Arterial ammonia and clinical risk factors for encephalopathy and intracranial hypertension in acute liver failure. *Hepatology* 2007;46:1844-52.
56. Cardoso FS, Gottfried M, Tujios S, Olson JC, Karvellas CJ, US Acute Liver Failure Study Group. Continuous renal replacement therapy is associated with reduced serum ammonia levels and mortality in acute liver failure. *Hepatology* 2018;67:711-20.
58. Slack AJ, Auzinger G, Willars C, et al. Ammonia clearance with haemofiltration in adults with liver disease. *Liver Int* 2014;34:42-8.



59. Warrillow S, Fisher C, Bellomo R. Correction and control of hyperammonemia in acute liver failure: the impact of continuous renal replacement timing, intensity, and duration. *Crit Care Med* 2020;48:218-24.
71. Davenport A, Will EJ, Davidson AM. Improved cardiovascular stability during continuous modes of renal replacement therapy in critically ill patients with acute hepatic and renal failure. *Crit Care Med* 1993;21:328-38.
72. Fontana RJ, Ellerbe C, Durkalski VE, et al. Two-year outcomes in initial survivors with acute liver failure: results from a prospective, multicentre study. *Liver Int* 2015;35:370-80.
73. Germani G, Theocharidou E, Adam R, et al. Liver transplantation for acute liver failure in Europe: outcomes over 20 years from the ELTR database. *J Hepatol* 2012;57:288-96.
75. Koch DG, Tillman H, Durkalski V, Lee WM, Reuben A. Development of a model to predict transplant-free survival of patients with acute liver failure. *Clin Gastroenterol Hepatol* 2016;14:1199-206 e2.
102. Stravitz RT, Kramer AH, Davern T, et al. Intensive care of patients with acute liver failure: recommendations of the U.S. Acute Liver Failure Study Group. *Crit Care Med* 2007;35:2498-508.
103. Karvellas CJ, Safinia N, Auzinger G, et al. Medical and psychiatric outcomes for patients transplanted for acetaminophen-induced acute liver failure: a case-control study. *Liver Int* 2010;30:826-33.

104. Pezzia C, Sanders C, Welch S, Bowling A, Lee WM, Acute Liver Failure Study Group. Psychosocial and behavioral factors in acetaminophen-related acute liver failure and liver injury. *J Psychosom Res* 2017;101:51-7.
105. Prescott LF, Critchley JA. The treatment of acetaminophen poisoning. *Annu Rev Pharmacol Toxicol* 1983;23:87-101.
106. Hamlyn AN, Douglas AP, James O. The spectrum of paracetamol (acetaminophen) overdose: clinical and epidemiological studies. *Postgrad Med J* 1978;54:400-4.
107. Simmons OL, Meinzer C, Rule J, Lee WM, US Acute Liver Failure Study Group. Liver transplantation for acetaminophen-induced acute liver failure: role of psychiatric comorbidity in listing decisions and outcomes. *Dig Dis Sci* 2019.
108. Koch DG, Speiser JL, Durkalski V, et al. The natural history of severe acute liver injury. *Am J Gastroenterol* 2017;112:1389-96.
109. Karvellas CJ, Speiser JL, Tremblay M, Lee WM, Rose CF, Group USALFS. Elevated FABP1 serum levels are associated with poorer survival in acetaminophen-induced acute liver failure. *Hepatology* 2017;65:938-49.
110. Blei AT. Medical therapy of brain edema in fulminant hepatic failure. *Hepatology* 2000;32:666-9.
111. Fujiwara K, Mochida S, Matsui A, et al. Fulminant hepatitis and late onset hepatic failure in Japan. *Hepatol Res* 2008;38:646-57.
112. Oketani M, Ido A, Nakayama N, et al. Etiology and prognosis of fulminant hepatitis and late-onset hepatic failure in Japan: summary of the annual nationwide survey between 2004 and 2009. *Hepatol Res* 2013;43:97-105.

113. Bhatia V, Singh R, Acharya SK. Predictive value of arterial ammonia for complications and outcome in acute liver failure. *Gut* 2006;55:98-104.
114. Clemmesen JO, Larsen FS, Kondrup J, Hansen BA, Ott P. Cerebral herniation in patients with acute liver failure is correlated with arterial ammonia concentration. *Hepatology* 1999;29:648-53.
115. Davenport A. Continuous renal replacement therapies in patients with acute neurological injury. *Semin Dial* 2009;22:165-8.
116. Davenport A. Is there a role for continuous renal replacement therapies in patients with liver and renal failure? *Kidney International* 1999;56:S62-S6.
117. Connors AF, Jr. Pitfalls in estimating the effect of interventions in the critically ill using observational study designs. *Crit Care Med* 2001;29:1283-4.

**CHAPTER 3—The Role of the Molecular Adsorbent Recirculating System in Acute  
Liver Failure**

### **3.1 Introduction**

Acute liver failure (ALF) is a rare disease characterized by acute hepatic injury resulting in hepatic encephalopathy (HE) and impaired hepatic function in patients without pre-existing liver disease.<sup>2,22</sup> Patients with ALF are critically ill, with subsequent intracranial hypertension (ICH) and cerebral edema (CE) carrying substantial neurologic morbidity and mortality risk.<sup>5,6</sup> Management is primarily supportive and aims to maintain hemodynamic stability and correct metabolic abnormalities.<sup>23,102</sup> Prognosis varies with etiology, with acetaminophen (APAP)-induced ALF patients displaying greater recovery potential. For those failing medical therapy, liver transplantation (LT) may confer improved survival, with approximately 20% of North American ALF patients receiving LT.<sup>7</sup> Critical illness and psychosocial factors may complicate listing decisions for LT, while many ALF patients may die waiting for a suitable donor graft in an era where organ demand greatly exceeds supply.<sup>17,103,104</sup>

Extracorporeal liver support (ECLS) systems represent a promising area in the medical management of ALF. The molecular adsorbent recirculating system (MARS; Baxter International Inc., Deerfield, United States), an albumin-based dialysis system, removes water-soluble and albumin-bound toxins, and may assist in bridging patients to donor organ availability or, alternatively, may supplement hepatic function while native organ recovery occurs.<sup>86</sup> The MARS albumin dialysis system has been shown to improve serum biochemistry and hemodynamics in ALF; however, studies have been unpowered to elucidate its role in transplant-free survival (TFS), particularly in APAP-ALF.<sup>96,97,118</sup>

Analyzing MARS-treated ALF patient data from three tertiary liver transplant centres and standard medical therapy (SMT)-treated ALF patient data from the multicentre United States Acute Liver Failure Study Group (US ALFSG) registry, we evaluated the role of MARS in ALF. Our objectives were to test the following hypotheses:

1. MARS therapy significantly improves serum biochemistry and hemodynamics.
2. TFS is significantly greater following MARS therapy compared to SMT controls.

### ***3.2 Patients and Methods***

#### ***3.2.1 Study Design***

A propensity score (PS)-matched retrospective cohort study of all ALF patients treated with MARS at three North American tertiary care hospitals (Emory University Hospital, Atlanta, United States; University of Alberta Hospital, Edmonton, Canada; University of Kansas Medical Center, Kansas City, United States) between January 2009 and January 2019 was performed. Eligible SMT controls were independently and prospectively enrolled in the US ALFSG registry between January 1998 and December 2019. All protocols were approved by the institutional review boards/health research ethics boards at participating sites (tertiary liver transplant referral centres). Where required, informed consent was obtained from each participant/next of kin. All research procedures were conducted according to the principles of the 1975 Declaration of Helsinki. Therapeutic interventions, including SMT algorithms, and initiation and cessation of MARS, were

implemented in accordance with institutional standards of care. Criteria for listing and performing LT were those utilized at participating centres.

### **3.2.2 Participants**

Enrollment criteria were as follows: (1) primary diagnosis of ALF as determined by the site investigator, (2) participant age  $\geq 18$  years, and (3) receipt of MARS therapy (MARS patients) or absence of receipt of MARS therapy (SMT patients). Standard medical therapy patients with missing values for any matched parameter(s) used in the propensity score calculation were not considered.

### **3.2.3 Operational Definitions**

Acute liver failure was defined using the following criteria: (1) international normalized ratio (INR)  $\geq 1.5$ , (2) HE of any grade (West Haven Criteria)<sup>119</sup>, (3) illness duration  $< 26$  weeks, and (4) absence of existing cirrhosis (note: patients with liver failure secondary to acute Wilson's disease or de novo presentation of pre-existing subclinical liver disease were considered). The King's College Criteria (KCC) predict poor outcomes in ALF.<sup>76</sup> In APAP-ALF, KCC are defined as either (1) arterial pH  $< 7.3$ , or (2) all three of the following criteria: i) INR  $> 6.5$ , ii) creatinine  $> 300$   $\mu\text{mol/L}$ , and iii) the presence of grade 3/4 HE. In non-APAP ALF, KCC are defined as (1) INR  $> 6.5$ , or (2) three of the following five criteria: i) age  $< 11$  years or  $> 40$  years, ii) non-HAV/non-HBV viral hepatitis or indeterminant or idiosyncratic drug-induced etiology, iii) jaundice-to-HE interval  $> 7$  days, iv) INR  $> 3.5$ , and

v) bilirubin >300 µmol/L. As HE gradings were not prospectively recorded for MARS patients, grade 3/4 HE was considered as Glasgow coma scale (GCS) score ≤10.

### ***3.2.4 Clinical Variables and Endpoints***

MARS patient covariates were collected through retrospective electronic medical record review. The US ALFSG registry (Medical University of South Carolina, Charleston, United States) contains prospectively collected clinical, biochemical, and outcome data. Data assessed included baseline patient characteristics (age, sex, ALF etiology), requirement of organ support (mechanical ventilation, vasopressors, renal replacement therapy (RRT)), biochemical parameters (complete blood count, INR, transaminases, bilirubin, pH, ammonia, creatinine, lactate), HE grade, and clinical outcomes (21-day TFS, overall 21-day survival, and transplantation). Additionally, hemodynamic parameters (heart rate, mean arterial pressure) were evaluated in MARS patients. Baseline parameters were defined as those most recently recorded prior to the initiation of MARS therapy (MARS patients) or those on admission (SMT patients). Post-MARS patient parameters were defined as those recorded immediately following cessation of MARS therapy. The primary endpoint for this study was 21-day TFS. Time zero was defined as follows: on intensive care unit admission in MARS patients, and on enrollment in the US ALFSG study in SMT patients. Secondary outcomes included changes in biochemical and hemodynamic parameters following MARS therapy in the exposed cohort.



### **3.2.5 Statistical Analysis**

We used a PS-matched, retrospective cohort design, which aimed to balance baseline characteristics and minimize potential confounding between MARS and SMT patients. Using logistic regression, significant baseline covariates (age, sex, APAP-ALF etiology, use of RRT, use of vasopressors, mechanical ventilation, presence of grade 3/4 HE, INR, bilirubin, creatinine, fulfillment of KCC) were identified to generate exposure PS values. Each PS represented the predicted probability of treatment with MARS therapy. A random matching of patients to controls within a maximum PS radius of 0.2 without replacement was used to select SMT patients for each MARS patient in a 1:4 ratio.<sup>120</sup> The radius method matches based on an allowable maximum difference between propensity scores. Different radius thresholds were examined with the goal of maximizing the number of matched cases to controls while maintaining an acceptable balance in baseline covariates. Matched cohort covariate balance was assessed using standardized mean differences (SMD). A covariate SMD threshold  $>0.2$  (absolute value) was considered unbalanced and accounted for using adjustment in multivariable modelling.<sup>121</sup>

Association of MARS therapy with 21-day TFS was completed using conditional logistic regression. For the primary analysis, we further adjusted for age, use of vasopressors, INR, and fulfillment of KCC (all  $|SMD|>0.2$ ), and APAP-ALF etiology. We conducted several sensitivity analyses to assess the consistency of the effect of MARS therapy. First, we evaluated MARS therapy adjusting for APAP-ALF etiology and continuous PS values (i.e. the probability of the patient receiving MARS therapy). Second, we evaluated MARS therapy adjusting for APAP-ALF etiology, continuous PS values, and

unbalanced ( $|\text{SMD}| > 0.2$ ) covariates. Third, we evaluated MARS therapy adjusting for APAP-ALF etiology and matched covariates with  $|\text{SMD}| > 0.1$  (age, use of vasopressors, mechanical ventilation, presence of grade 3/4 HE, INR, and fulfillment of KCC). Fourth, we evaluated MARS therapy adjusting for APAP-ALF etiology, matched covariates with  $|\text{SMD}| > 0.1$ , and continuous PS values. Finally, we evaluated MARS therapy in the matched population adjusting for APAP-ALF etiology only.

We further investigated MARS patients, grouped by ALF etiology: APAP and non-APAP. Pre-/post-MARS categorical covariates were presented as proportions and compared using the Chi-squared test. Complete pair pre-/post-MARS continuous covariates were presented as medians with interquartile ranges (IQR) or means with standard deviations following assessment for normality using skewness ( $\pm 0.5$ ) and kurtosis ( $\pm 2$ ). Continuous covariates compared using the Wilcoxon Signed Rank test or paired Student's t-test, where appropriate.

All analyses were two-tailed. We used a threshold for statistical significance of 0.05. Statistical analysis was performed using Stata (version 16.1; StataCorp, College Station, Texas, USA) and SAS (version 9.4; SAS Institute, Cary, North Carolina, USA).

### **3.3 Results**

#### **3.3.1 Baseline Patient Parameters**

A total of 104 patients were treated with MARS between December 2009 and January 2019. The unmatched SMT population included 1544 eligible patients enrolled within the

US ALFSG registry between January 1998 and December 2019. Propensity score matching yielded a cohort of 520 ALF patients; 104 MARS patients matched 1:4 with 416 SMT control patients (Figure 3.1). Following PS matching, ALF etiology (APAP versus non-APAP), sex, use of RRT, mechanical ventilation, presence of grade 3/4 HE, serum bilirubin, and serum creatinine SMDs were <0.2 (absolute values) between treatment groups, indicating acceptable covariate balance. Patient age, use of vasopressors, INR, and fulfillment of KCC were unbalanced between matched treatment groups, requiring adjustment consideration in subsequent modelling. Matched demographic and clinical parameters are described in Table 3.1. Additional, non-matched, baseline parameters are summarized in Table 3.2.

### **3.3.2 MARS Protocols**

Case patients received a median (IQR) of 3.0 (1.5-4.0) MARS therapy sessions, with a median (IQR) total treatment duration of 24.0 (9.0-33.1) hours. Use of citrate anticoagulation was most common (55.8%), followed by no anticoagulation (31.7%). Notably, all participating institutions utilised PRISMAFLEX (Baxter International Inc., Deerfield, United States) RRT as part of MARS therapy setup. Table 3.3 summarizes MARS therapy protocol parameters.

### **3.3.3 Comparisons of Pre-MARS and Post-MARS Parameters**

Changes in clinical and biochemical parameters following receipt of MARS therapy (compared to those prior to intervention), stratified by ALF etiology (APAP and non-APAP), are shown in Table 3.4. Among APAP-ALF patients, significantly fewer required vasopressor support following MARS (post-MARS: 37.3% vs. pre-MARS: 49.0%), in the setting of significantly decreased median heart rate (92.0 vs. 102.0 beats/minute) and increased median mean arterial pressure (92.0 vs. 78.0 mm Hg;  $p \leq 0.016$  for all). Significant reductions in median INR (2.8 vs. 4.3), creatinine (77.0 vs. 128.2  $\mu\text{mol/L}$ ), lactate (2.3 vs. 4.3 mmol/L), and ammonia (98.0 vs. 136.0  $\mu\text{mol/L}$ ;  $p < 0.001$  for all) were observed following MARS therapy. A statistically significant increase in median bilirubin (101.0 vs. 82.1  $\mu\text{mol/L}$ ;  $p = 0.041$ ) was seen following MARS, with no concomitant change in post-MARS median model for end-stage liver disease (MELD) score.

In the case of non-APAP ALF patients receiving MARS, significantly more patients required vasopressor support following intervention (43.4% vs. 34.0%;  $p < 0.001$ ) to maintain median heart rate and mean arterial pressure. Significant reductions in median bilirubin (205.2 vs. 251.4  $\mu\text{mol/L}$ ), creatinine (83.1 vs. 133.5  $\mu\text{mol/L}$ ), and ammonia (111.5 vs. 140.0  $\mu\text{mol/L}$ ;  $p \leq 0.020$  for all) were recorded following MARS therapy; however, a significant increase in post-MARS median MELD score (43.0 vs. 36.5;  $p < 0.001$ ) was observed.

In both APAP and non-APAP ALF patients, significantly more patients displayed grade 3/4 HE following MARS therapy (62.7% vs. 56.7%, and 50.9% vs. 49.1%;  $p < 0.001$  for both).

### **3.3.4 Multivariable Analyses: Associations with TFS**

Multivariable conditional logistic regression was performed to determine associations with 21-day TFS in the PS-matched cohort (Table 3.5 and Figure 3.2). After adjusting for unbalanced matched covariates (age, use of vasopressors, INR, and fulfillment of KCC) and ALF etiology, *MARS therapy was not significantly associated with 21-day TFS (OR 1.60; 95% CI: 0.93-2.76; p=0.093)*. The effect of MARS therapy was statistically significant in several sensitivity analyses: adjusting for ALF etiology and continuous PS values (MARS OR 1.86; 95% CI: 1.05-3.31; p=0.033; Table 3.6); adjusting for ALF etiology, unbalanced matched covariates, and continuous PS values (MARS OR 1.90; 95% CI: 1.07-3.39; p=0.030; Table 3.7); and adjusting for ALF etiology, matched covariates with |SMD|>0.1, and continuous PS values (MARS OR 1.91; 95% CI: 1.07-3.41; p=0.029; Table 3.9). Two additional sensitivity analysis models found no association between MARS therapy and 21-day TFS: adjusting for ALF etiology and matched covariates with |SMD|>0.1 (MARS OR 1.60; 95% CI: 0.92-2.76; p=0.094; Table 3.9); and adjusting for adjusting for ALF etiology (MARS OR 0.91; 95% CI: 0.56-1.48; p=0.712; Table 3.10). Additional outcomes at day 21 are summarized in Table 3.11.

### **3.4 Discussion**

#### **3.4.1 Key Results**

Using a PS-matched ALF patient cohort, MARS-treated patients displayed similar 21-day TFS (51.9%) compared to SMT controls (52.9%). After adjusting for covariates reflecting likelihood of MARS treatment (i.e. severity of critical illness; age, use of vasopressors, INR, fulfillment of KCC, and ALF etiology), use of MARS was not independently associated with increased odds of 21-day TFS over SMT alone. Notably, incorporation of adjustment for continuous PS values in several sensitivity analyses found MARS to be significantly associated with increased 21-day TFS. Following MARS, significant improvement in hemodynamic status was observed in APAP-ALF patients, while significant improvements in biochemical parameters were observed in both APAP and non-APAP ALF patients.

#### **3.4.2 Comparison with the Literature**

Various ECLS systems have been developed to support ALF patients, with the MARS albumin dialysis system being the most studied. By removing hydrophilic and albumin-bound toxins, MARS therapy has been reported to significantly improve both biochemical parameters and hemodynamics when compared with SMT.<sup>95,97,118</sup> In the present study, significantly fewer APAP-ALF patients required vasopressor support following MARS, with patients displaying increased mean arterial pressure. Further, significant reductions

in creatinine, lactate, and ammonia in APAP-ALF, and creatinine, bilirubin, and ammonia in non-APAP ALF were recorded. High serum ammonia levels are believed to play a role in the pathogenesis of CE and are associated with worsening HE and ICH in ALF.<sup>55,113,114</sup> Both MARS and CRRT (a component of the MARS set-up) have been shown to significantly reduce serum ammonia levels.<sup>56,58,59,95,97</sup> Though not described in ALF-specific studies, an improvement in HE grade following MARS therapy has been displayed in acute-on-chronic liver failure patients.<sup>122-124</sup> In the present study, grade 3/4 HE was observed to be more prevalent following MARS.

Beyond informal case series, no mortality benefit following MARS therapy has been observed in previous ALF studies.<sup>95,97,118</sup> Saliba and colleagues reported results of the largest randomized controlled trial on MARS in ALF (FULMAR study).<sup>96</sup> Comparing MARS (n=53) versus SMT (n=49) patients, 6-month survival did not differ between groups (85% vs. 76%; p=0.28). Notably, median listing-to-LT time was only 16.2 hours, with 14 patients receiving less than 5 hours of MARS prior to death or LT. As LT serves as a definitive management strategy in ALF, ECLS study patients frequently fail to receive minimum treatment durations, potentially compromising assessments of effects on clinical outcomes.

Larsen and colleagues reported a clinically and statistically significant increase in TFS in ALF patients receiving high volume plasma exchange (HVP).<sup>100</sup> Of 182 patients randomized to receive HVP and SMT (n=92) or SMT alone (n=90), survival to hospital discharge was 58.7% for patients treated with HVP and 47.8% for patients who received SMT alone (hazard ratio for HVP vs. SMT, with stratification for LT: 0.56; 95% CI: 0.36-0.86; p=0.0083). No survival advantage was noted in patients ultimately receiving LT.

This remains the only trial identifying a potential role for ECLS in non-transplanted ALF patients.

In the present study, MARS therapy was associated with a trend towards increased 21-day TFS. It has been hypothesized that ECLS may create an environment for hepatic recovery and reverse underlying mechanisms of hepatocyte injury, thus, promoting TFS. Prognostic potential in ALF patients varies with underlying etiology.<sup>7,23</sup> Specifically, APAP-ALF patients display greater potential for hepatic regeneration and survival without LT. In a subgroup analysis of FULMAR study APAP-ALF patients, MARS therapy was associated with greater, though not statistically significant, 6-month overall survival compared with SMT alone (85% vs. 68%;  $p=0.46$ ).<sup>96</sup> Ultimately, the FULMAR study may have been underpowered to reveal a MARS-related survival advantage in APAP-ALF.

Furthermore, treatment with HVP has been shown to dampen systemic inflammatory response through reductions in neutrophil activation, and circulating levels of damage-associated molecular patterns and proinflammatory cytokines.<sup>100</sup> As APAP-ALF is associated with an abrupt generalized inflammatory cascade, the potential role of MARS in immunomodulation necessitates further study.<sup>125</sup>

### ***3.4.3 Strengths and Limitations***

Interpretation of this study should consider its strengths and limitations. Strengths include use of, to the best of our knowledge, the largest cohort of ALF patients receiving MARS therapy and inclusion of SMT controls from multiple North American centres, lending to reasonable generalizability. Acute liver failure is a rare disease where controlled trials



remain both ethically and practically challenging. This study's PS-matched design provides a feasible alternative and serves to address potential residual confounding interfering with determination of associations in observational studies. Previous MARS studies have focused on overall survival<sup>96</sup>, where early LT may serve as a competing risk, decreasing MARS exposure (i.e. duration) and biasing the assessment of MARS-related association with TFS. Transplantation rate among MARS patients in the present study was lower than that of the intention-to-treat FULMAR study (22.1% vs. 73.6%), with 99/104 patients receiving at least one 8-hour MARS session. As our study focuses on associations with TFS, LT is plausibly less likely to have confounded the demonstrated association between TFS and MARS therapy. Regarding its limitations, neither MARS nor SMT protocols were standardized across participating institutions, and this retrospective analysis of observational data may comment only on association; we are unable to conclusively exclude sources of selection bias.<sup>117</sup> Though subjects were PS-matched, a number of covariates remained imbalanced between matched treatment groups, necessitating further adjustment. Multivariable modelling adjusting for continuous PS values found MARS to be independently associated with 21-day TFS, perhaps reflecting patient cohort heterogeneity not addressed in the main model. Classification of HE grade was established retrospectively using recorded GCS values. As well, one must consider the influence of sedating medications used within the intensive care setting and their potential impact on both pre- and post-MARS GCS values. As many of these patients were critically ill and required mechanical ventilation in the setting of multi-system organ failure, concomitant use of sedating medications may have served as a confounding factor. Despite these limitations, this study represents the largest cohort of MARS-treated

ALF patients evaluating its association with TFS. Though not uniformly statistically significant, MARS therapy was associated with a trend towards improved 21-day TFS, underscoring the potential therapeutic role of MARS in ALF patients not receiving LT.

### **3.5 Conclusion**

In a large multicentre PS-matched cohort study of ALF patients, MARS therapy significantly improved hemodynamic and biochemical parameters, particularly in APAP-ALF patients. Treatment with MARS was associated with significantly increased 21-day TFS over SMT alone. Further controlled trials aiming to identify the subset of ALF patients who derive MARS-related survival advantage would be of interest.

**Table 3.1.** Matched baseline (pre-MARS/admission) characteristics of MARS and SMT treated patients after propensity score matching.

<b>Matched Parameter</b>	<b>MARS (N=104)</b>	<b>SMT (N=416)</b>	<b>Standardized Mean Difference<sup>‡</sup></b>
<b>APAP Etiology</b>	51 (49.0%)	197 (47.4%)	0.03368
<b>Age</b>	39.4 (14.9)	42.5 (15.4)	0.20398
<b>Sex (male)</b>	39 (37.5%)	137 (32.9%)	0.09573
<b>RRT</b>	32 (30.8%)	114 (27.4%)	0.07415
<b>Vasopressor Support</b>	43 (41.3%)	110 (26.4%)	0.31883
<b>Mechanical Ventilation</b>	56 (53.8%)	198 (47.6%)	0.12526
<b>Grade 3/4 HE</b>	55 (52.9%)	192 (46.2%)	0.13493
<b>INR</b>	4.7 (2.8)	3.8 (2.3)	-0.34565
<b>Bilirubin (µmol/L)</b>	213.4 (206.2)	180.6 (187.2)	-0.16665
<b>Creatinine (µmol/L)</b>	171.5 (129.1)	179.5 (132.6)	0.06135
<b>KCC met</b>	52 (50.0%)	142 (34.1%)	0.32561

Data presented as n (%) or mean (standard deviation), where appropriate.

<sup>‡</sup> A standardized mean difference <0.2 (absolute value) is considered acceptable covariate balance.

Abbreviations: *APAP*, acetaminophen; *HE*, hepatic encephalopathy; *INR*, international normalized ratio; *KCC*, King’s College Criteria; *MARS*, molecular adsorbent recirculating system; *SMT*, standard medical therapy; *RRT*, renal replacement therapy.

**Table 3.2.** Additional non-matched baseline (pre-MARS/admission) characteristics of MARS and SMT treated patients.

Parameter	MARS (N=104)		SMT (N=416)	
	N	n (%) or Median (IQR)	N	n (%) or Median (IQR)
<b>Etiology</b>	104		416	
APAP		51 (49.0%)		197 (47.4%)
Viral Hepatitis		5 (4.8%)		32 (7.7%)
Drug-Induced (Non-APAP)		17 (16.3%)		37 (8.9%)
Autoimmune Hepatitis		4 (3.8%)		30 (7.2%)
Wilson's Disease		3 (2.9%)		5 (1.2%)
Indeterminant		10 (9.6%)		35 (8.4%)
Other		14 (13.4%)		80 (19.2%)
<b>MELD</b>	104	38.0 (30.5-42.5)	416	32.0 (26.0-39.0)
<b>Biochemistry</b>				
Hemoglobin (g/L)	104	100.5 (88.0-116.0)	412	107.0 (92.0-122.0)
White Blood Cells (10 <sup>9</sup> cells/L)	104	10.0 (7.3-14.5)	412	10.2 (6.7-14.3)
Platelets (10 <sup>9</sup> cells/L)	104	98.5 (62.5-151.5)	411	122.0 (75.0-182.0)
ALT (units/L)	104	3079.5 (1003.5-5677.5)	415	2087.0 (616.0-4417.0)
AST (units/L)	104	3040.5 (561.0-7775.5)	414	1814.0 (463.0-5167.0)
Lactate (mmol/L)	98	4.0 (2.7-7.5)	242	3.7 (2.3-7.2)
Ammonia (µmol/L)	87	125.0 (80.0-252.0)	270	103.0 (68.0-176.0)
PaO <sub>2</sub> /FiO <sub>2</sub> Ratio	100	370.7 (286.1-453.8)	191	325.0 (189.5-430.0)

Abbreviations: *ALT*, alanine aminotransferase; *APAP*, acetaminophen; *AST*, aspartate aminotransferase; *FiO<sub>2</sub>*, fraction of inspired oxygen; *INR*, international normalized ratio; *IQR*, interquartile range; *MARS*, molecular adsorbent recirculating system; *PaO<sub>2</sub>*, partial pressure of oxygen (arterial); *SMT*, standard medical therapy.

**Table 3.3.** Summary of MARS therapy parameters (n=104).

<b>MARS Therapy Parameter</b>	<b>n (%) or Median (IQR)</b>
<b>Sessions</b>	3.0 (1.5-4.0)
<b>Total Duration (hours)</b>	24.0 (9.0-33.1)
<b>Maximum Blood Flow (mL/min)</b>	180.0 (180.0-200.0)
<b>Maximum Albumin Flow (mL/min)</b>	180.0 (180.0-180.0)
<b>Anticoagulation</b>	
Heparin	13 (12.5%)
Citrate	58 (55.8%)
None	33 (31.7%)

Note: *All participating institutions utilised PRISMAFLEX (Baxter International Inc., Deerfield, Illinois) renal replacement therapy system as part of MARS setup.*

Abbreviations: *IQR*, interquartile range; *MARS*, molecular adsorbent recirculating system.

**Table 3.4.** Comparative analysis of clinical and biochemical parameters following MARS therapy, grouped by ALF etiology.

Parameter	APAP (N=51)			
	N	Pre-MARS	Post-MARS	P-value
<b>Vasopressor Support</b>	51	25 (49.0%)	19 (37.3%)	0.001
<b>Grade 3/4 HE</b>	51	29 (56.7%)	32 (62.7%)	<0.001
<b>MELD</b>	51	39.0 (31.0-44.0)	38.0 (32.0-45.0)	0.998
<b>Hemodynamics</b>				
Heart Rate (beats/minute)	51	102.0 (86.0-116.0)	92.0 (76.0-105.0)	0.016
Mean Arterial Pressure (mm Hg)	51	78.0 (69.0-96.0)	92.0 (75.0-100.0)	0.002
<b>Biochemistry</b>				
Hemoglobin (g/L)	51	105.0 (91.0-120.0)	92.0 (83.0-104.0)	<0.001
White Blood Cells (10 <sup>9</sup> cells/L)	51	8.8 (6.0-14.0)	8.5 (5.4-12.8)	0.322
Platelets (10 <sup>9</sup> cells/L)	51	101.0 (64.0-166.0)	70.0 (34.0-113.0)	<0.001
INR	50	4.3 (3.1-7.3)	2.8 (1.7-4.5)	<0.001
ALT (units/L)	51	4871.0 (2909.0-6650.0)	2070.0 (1061.0-3402.0)	<0.001
AST (units/L)	51	6337.0 (2600.0-10833.0)	751.0 (200.0-1721.0)	<0.001
Bilirubin (µmol/L)	51	82.1 (59.9-114.6)	101.0 (61.6-171.0)	0.041
Creatinine (µmol/L)	51	128.2 (79.0-247.5)	77.0 (46.9-126.4)	<0.001
Lactate (mmol/L)	45	4.3 (3.1-7.5)	2.3 (1.5-3.5)	<0.001
Ammonia (µmol/L)	37	136.0 (110.0-261.0)	98.0 (71.0-154.0)	<0.001
PaO <sub>2</sub> /FiO <sub>2</sub> Ratio	50	390.2 (300.0-497.5)	406.1 (300.0-476.0)	0.783
<b>Non-APAP (N=53)</b>				
Parameter	Non-APAP (N=53)			
	N	Pre-MARS	Post-MARS	P-value
<b>Vasopressor Support</b>	53	18 (34.0%)	23 (43.4%)	<0.001
<b>Grade 3/4 HE</b>	51	26 (49.1%)	27 (50.9%)	<0.001
<b>MELD</b>	50	36.5 (30.0-42.0)	43.0 (35.0-49.0)	<0.001
<b>Hemodynamics</b>				
Heart Rate (beats/minute)	53	91.0 (78.0-105.0)	91.0 (77.0-106.0)	0.581
Mean Arterial Pressure (mm Hg)	53	84.0 (68.0-98.0)	86.0 (74.0-93.0)	0.278
<b>Biochemistry</b>				

Hemoglobin (g/L)	53	95.0 (84.0-113.0)	87.0 (75.0-103.0)	<0.001
White Blood Cells (10 <sup>9</sup> cells/L)	51	11.1 (7.6-15.7)	12.6 (6.3-19.2)	0.913
Platelets (10 <sup>9</sup> cells/L)	51	90.0 (60.0-143.0)	55.0 (40.0-95.0)	<0.001
INR	51	3.5 (2.3-5.7)	3.1 (1.9-5.4)	0.725
ALT (units/L)	51	1441.0 (100.0-3890.0)	911.0 (166.0-1496.0)	0.001
AST (units/L)	51	1178.0 (175.0-4099.0)	475.0 (162.0-1955.0)	0.006
Bilirubin (µmol/L)	51	251.4 (135.0-435.0)	205.2 (147.1-347.1)	0.020
Creatinine (µmol/L)	51	133.5 (69.0-279.3)	83.1 (59.2-127.0)	<0.001
Lactate (mmol/L)	42	4.2 (2.3-8.0)	3.9 (2.0-9.2)	0.956
Ammonia (µmol/L)	30	140.0 (88.0-273.0)	111.5 (51.0-210.0)	0.022
PaO <sub>2</sub> /FiO <sub>2</sub> Ratio	48	334.7 (243.5-406.0)	322.1 (180.8-420.0)	0.123

Data presented as n (%) or median (interquartile range), where appropriate.

Note: *Comparisons of paired pre- versus post-MARS parameters completed using Wilcoxon Signed Rank test (only complete pairs analyzed; exact p-value reported).*

Abbreviations: *ALT*, alanine aminotransferase; *APAP*, acetaminophen; *AST*, aspartate aminotransferase; *FiO<sub>2</sub>*, fraction of inspired oxygen; *HE*, hepatic encephalopathy; *INR*, international normalized ratio; *MARS*, molecular adsorbent recirculating system; *MELD*, model for endstage liver disease; *PaO<sub>2</sub>*, partial pressure of oxygen (arterial).

**Table 3.5.** Predictors of 21-day transplant-free survival in a propensity score-matched cohort: main model (MARS: n=104; SMT: n=416).

<b>Parameter</b>	<b>OR</b>	<b>95% OR Confidence Interval</b>		<b>P-value</b>
<b>MARS treatment<sup>‡</sup></b>	1.60	0.93	2.76	0.093
<b>APAP Etiology</b>	4.34	2.59	7.28	<0.001
<b>Age</b>	1.00	0.98	1.02	0.945
<b>Vasopressor Support</b>	0.33	0.18	0.59	<0.001
<b>INR</b>	0.83	0.74	0.93	0.002
<b>KCC met</b>	0.37	0.21	0.65	<0.001

<sup>‡</sup> Reference group: standard medical therapy.

Note: Model adjusts for covariates with standardized mean difference >0.2 (absolute value).

Abbreviations: *APAP*, acetaminophen; *INR*, international normalized ratio; *KCC*, King's College Criteria; *MARS*, molecular adsorbent recirculating system; *OR*, odds ratio.



**Table 3.6.** Predictors of 21-day transplant-free survival: sensitivity analysis model one (MARS: n=104; SMT: n=416).

Parameter	OR	95% OR Confidence Interval		P-value
<b>MARS treatment<sup>‡</sup></b>	1.86	1.05	3.31	0.033
<b>APAP Etiology</b>	6.21	3.75	10.29	<0.001
<b>Propensity Score</b>	<0.001	<0.001	<0.001	<0.001

<sup>‡</sup> Reference group: standard medical therapy.

Abbreviations: APAP, acetaminophen; MARS, molecular adsorbent recirculating system;

OR, odds ratio.

**Table 3.7.** Predictors of 21-day transplant-free survival: sensitivity analysis model two (MARS: n=104; SMT: n=416).

Parameter	OR	95% OR Confidence Interval		P-value
<b>MARS treatment<sup>‡</sup></b>	1.90	1.07	3.39	0.030
<b>APAP Etiology</b>	5.21	3.00	9.07	<0.001
<b>Propensity Score</b>	<0.001	<0.001	0.36	0.027
<b>Age</b>	0.99	0.97	1.01	0.234
<b>Vasopressor Support</b>	0.67	0.28	1.59	0.363
<b>INR</b>	0.91	0.79	1.05	0.201
<b>KCC met</b>	0.66	0.31	1.40	0.278

<sup>‡</sup> Reference group: standard medical therapy.

Note: Model adjusts for covariates with standardized mean difference >0.2 (absolute value).

Abbreviations: APAP, acetaminophen; INR, international normalized ratio; KCC, King's College Criteria; MARS, molecular adsorbent recirculating system; OR, odds ratio.

**Table 3.8.** Predictors of 21-day transplant-free survival: sensitivity analysis model three (MARS: n=104; SMT: n=416).

Parameter	OR	95% OR Confidence Interval		P-value
<b>MARS treatment<sup>‡</sup></b>	1.91	1.07	3.41	0.029
<b>APAP Etiology</b>	5.41	3.08	9.48	<0.001
<b>Propensity Score</b>	<0.001	<0.001	0.21	0.019
<b>Age</b>	0.99	0.97	1.01	0.211
<b>Vasopressor Support</b>	0.74	0.30	1.84	0.521
<b>Mechanical Ventilation</b>	0.66	0.35	1.22	0.183
<b>Grade 3/4 HE</b>	1.46	0.80	2.67	0.216
<b>INR</b>	0.91	0.79	1.05	0.213
<b>KCC met</b>	0.70	0.33	1.48	0.346

<sup>‡</sup> Reference group: standard medical therapy.

Note: Model adjusts for covariates with standardized mean difference >0.1 (absolute value).

Abbreviations: APAP, acetaminophen; HE, hepatic encephalopathy; INR, international normalized ratio; KCC, King's College Criteria; MARS, molecular adsorbent recirculating system; OR, odds ratio.

**Table 3.9.** Predictors of 21-day transplant-free survival: sensitivity analysis model four (MARS: n=104; SMT: n=416).

<b>Parameter</b>	<b>OR</b>	<b>95% OR Confidence Interval</b>		<b>P-value</b>
<b>MARS treatment<sup>‡</sup></b>	1.60	0.92	2.76	0.094
<b>APAP Etiology</b>	4.41	2.62	7.43	<0.001
<b>Age</b>	1.00	0.98	1.02	0.929
<b>Vasopressor Support</b>	0.35	0.18	0.67	0.001
<b>Mechanical Ventilation</b>	0.70	0.38	1.29	0.248
<b>Grade 3/4 HE</b>	1.33	0.74	2.39	0.341
<b>INR</b>	0.83	0.74	0.93	0.002
<b>KCC met</b>	0.38	0.22	0.66	<0.001

<sup>‡</sup> Reference group: standard medical therapy.

Note: Model adjusts for covariates with standardized mean difference >0.1 (absolute value).

Abbreviations: APAP, acetaminophen; HE, hepatic encephalopathy; INR, international normalized ratio; KCC, King's College Criteria; MARS, molecular adsorbent recirculating system; OR, odds ratio.

**Table 3.10.** Predictors of 21-day transplant-free survival: sensitivity analysis model five (MARS: n=104; SMT: n=416).

Parameter	OR	95% OR Confidence Interval		P-value
<b>MARS treatment<sup>‡</sup></b>	0.91	0.56	1.48	0.712
<b>APAP Etiology</b>	4.43	2.81	6.99	<0.001

<sup>‡</sup> Reference group: standard medical therapy.

Abbreviations: APAP, acetaminophen; MARS, molecular adsorbent recirculating system;

OR, odds ratio.

**Table 3.11.** Outcomes at 21 days following treatment with MARS or SMT.

<b>Outcome</b>	<b>MARS (N=104)</b>	<b>SMT (N=416)</b>
<b>Listed for Transplant</b>	31 (29.8%)	98 (23.6%)
<b>Received Transplant</b>	23 (22.1%)	78 (18.8%)
<b>Survived</b>	74 (71.2%)	292 (70.2%)
<b>Transplant-free Survived</b>	54 (51.9%)	220 (52.9%)

Abbreviations: *MARS*, molecular adsorbent recirculating system; *SMT*, standard medical therapy.

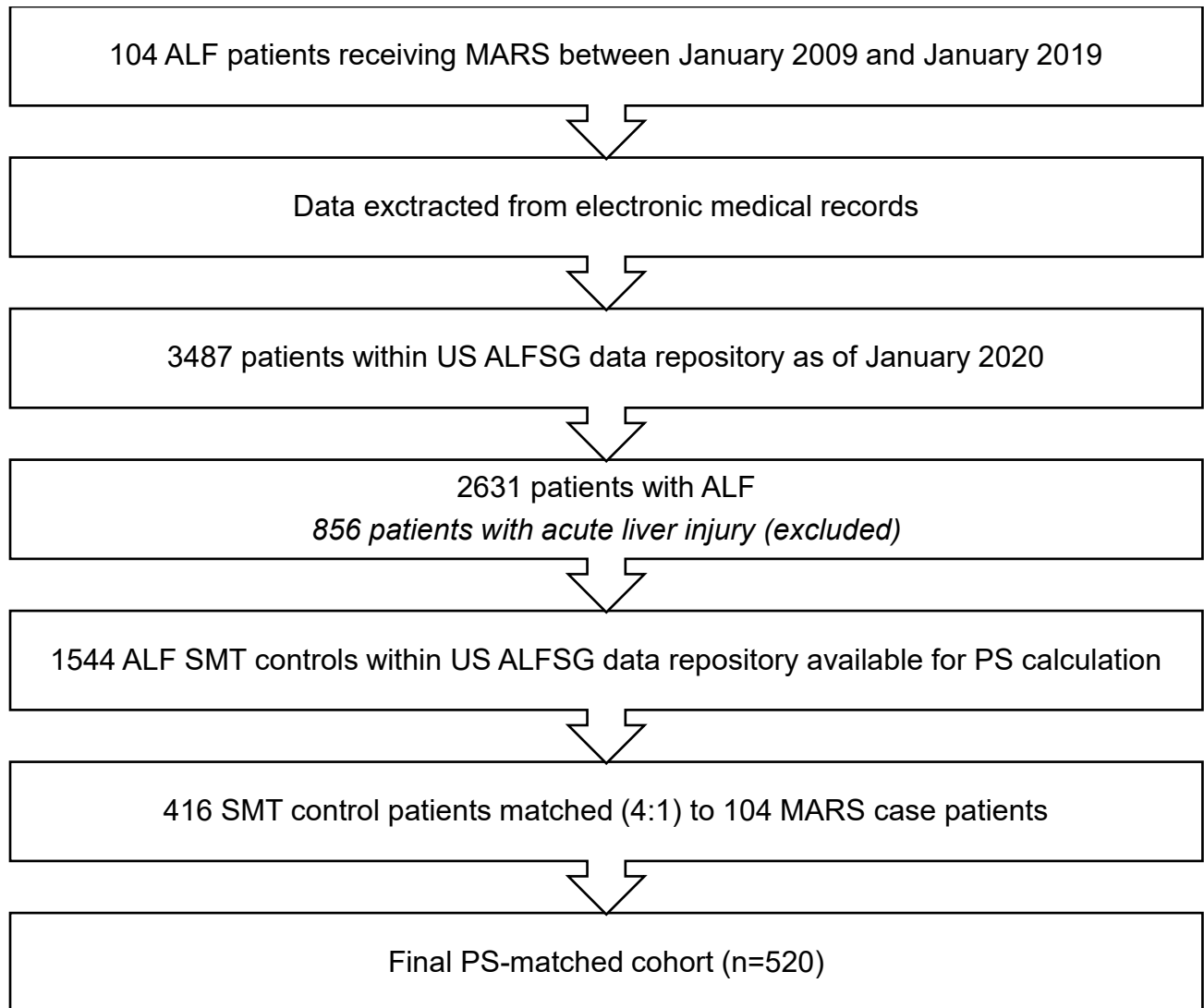

**Figure 3.1.** Patient selection flow diagram.

Abbreviations: *ALF*, acute liver failure; *MARS*, molecular adsorbent recirculating system; *PS*, propensity score; *SMT*, standard medical therapy; *US ALFSG*, United States Acute Liver Failure Study Group.

## 21-day Transplant-free Survival

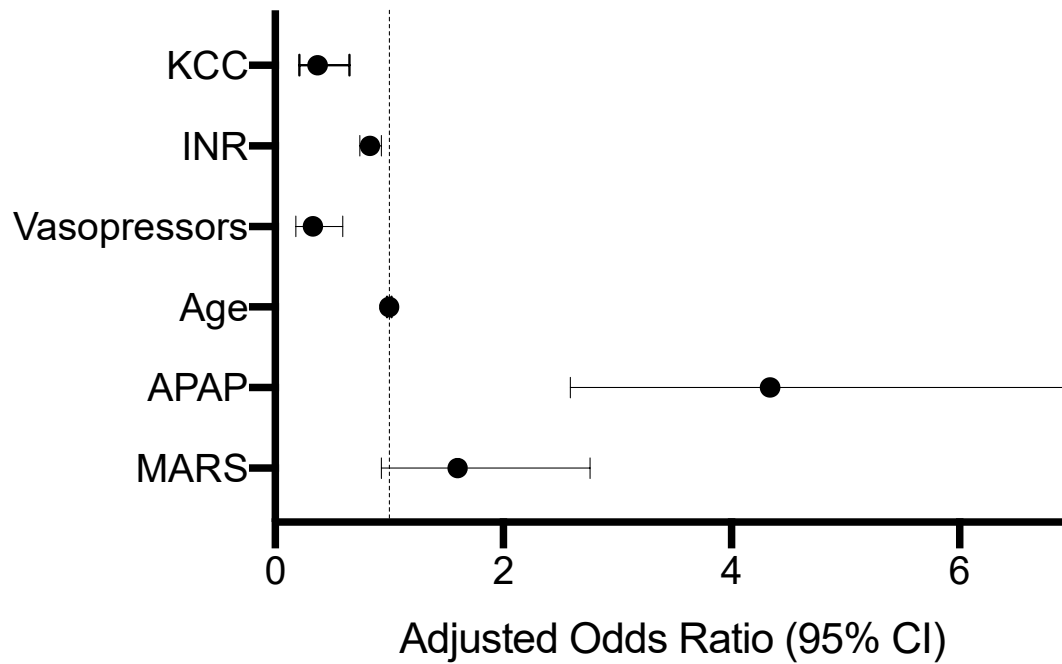

**Figure 3.2.** Adjusted associations with 21-day transplant-free survival in 520 propensity-score matched ALF patients: main model.

Abbreviations: *APAP*, acetaminophen; *INR*, international normalized ratio; *KCC*, King's College Criteria; *MARS*, molecular adsorbent recirculating system.



### **3.6 References**

2. O'Grady JG, Williams R. Classification of acute liver failure. *Lancet* 1993;342:743.
5. Ware AJ, D'Agostino AN, Combes B. Cerebral edema: a major complication of massive hepatic necrosis. *Gastroenterology* 1971;61:877-84.
6. Bernal W, Wendon J. Acute liver failure; clinical features and management. *Eur J Gastroenterol Hepatol* 1999;11:977-84.
7. Reuben A, Tillman H, Fontana RJ, et al. Outcomes in adults with acute liver failure between 1998 and 2013: an observational cohort study. *Ann Intern Med* 2016;164:724-32.
17. Ostapowicz G, Fontana RJ, Schiodt FV, et al. Results of a prospective study of acute liver failure at 17 tertiary care centers in the United States. *Ann Intern Med* 2002;137:947-54.
22. Lee WM, Stravitz RT, Larson AM. Introduction to the revised American Association for the Study of Liver Diseases position paper on acute liver failure 2011. *Hepatology* 2012;55:965-7.
23. Bernal W, Hyyrylainen A, Gera A, et al. Lessons from look-back in acute liver failure? A single centre experience of 3300 patients. *J Hepatol* 2013;59:74-80.
55. Bernal W, Hall C, Karvellas CJ, Auzinger G, Sizer E, Wendon J. Arterial ammonia and clinical risk factors for encephalopathy and intracranial hypertension in acute liver failure. *Hepatology* 2007;46:1844-52.

56. Cardoso FS, Gottfried M, Tujios S, Olson JC, Karvellas CJ, US Acute Liver Failure Study Group. Continuous renal replacement therapy is associated with reduced serum ammonia levels and mortality in acute liver failure. *Hepatology* 2018;67:711-20.
58. Slack AJ, Auzinger G, Willars C, et al. Ammonia clearance with haemofiltration in adults with liver disease. *Liver Int* 2014;34:42-8.
59. Warrillow S, Fisher C, Bellomo R. Correction and control of hyperammonemia in acute liver failure: the impact of continuous renal replacement timing, intensity, and duration. *Crit Care Med* 2020;48:218-24.
76. O'Grady JG, Alexander GJ, Hayllar KM, Williams R. Early indicators of prognosis in fulminant hepatic failure. *Gastroenterology* 1989;97:439-45.
86. Stange J, Ramlow W, Mitzner S, Schmidt R, Klinkmann H. Dialysis against a recycled albumin solution enables the removal of albumin-bound toxins. *Artificial Organs* 1993;17:809-13.
95. Novelli G, Rossi M, Pretagostini R, et al. MARS (molecular adsorbent recirculating system): experience in 34 cases of acute liver failure. *Liver* 2002;22:43-7.
96. Saliba F, Camus C, Durand F, Mathurin P, et al. Albumin dialysis with a noncell artificial liver support device in patients with acute liver failure: a randomized, controlled trial. *Annals of Internal Medicine* 2013;159:522-31.
97. Schmidt LE, Wang LP, Hansen BA, Larsen FS. Systemic hemodynamic effects of treatment with the molecular adsorbents recirculating system in patients with hyperacute liver failure: a prospective controlled trial. *Liver Transplantation* 2003;9:290-7.

100. Larsen FS, Schmidt LE, Bernsmeier C, et al. High-volume plasma exchange in patients with acute liver failure: an open randomised controlled trial. *Journal of Hepatology* 2016;64:69-78.
102. Stravitz RT, Kramer AH, Davern T, et al. Intensive care of patients with acute liver failure: recommendations of the U.S. Acute Liver Failure Study Group. *Crit Care Med* 2007;35:2498-508.
103. Karvellas CJ, Safinia N, Auzinger G, et al. Medical and psychiatric outcomes for patients transplanted for acetaminophen-induced acute liver failure: a case-control study. *Liver Int* 2010;30:826-33.
104. Pezzia C, Sanders C, Welch S, Bowling A, Lee WM, Acute Liver Failure Study Group. Psychosocial and behavioral factors in acetaminophen-related acute liver failure and liver injury. *J Psychosom Res* 2017;101:51-7.
113. Bhatia V, Singh R, Acharya SK. Predictive value of arterial ammonia for complications and outcome in acute liver failure. *Gut* 2006;55:98-104.
114. Clemmesen JO, Larsen FS, Kondrup J, Hansen BA, Ott P. Cerebral herniation in patients with acute liver failure is correlated with arterial ammonia concentration. *Hepatology* 1999;29:648-53.
117. Connors AF, Jr. Pitfalls in estimating the effect of interventions in the critically ill using observational study designs. *Crit Care Med* 2001;29:1283-4.
118. Banayosy AE, Kizner L, Schueler V, Bergmeier S, Cobaugh D, Koerfer R. First use of the molecular adsorbent recirculating system technique on patients with hypoxic liver failure after cardiogenic shock. *ASAIO Journal* 2004;50:332-7.

119. Atterbury CE, Maddrey WC, Conn HO. Neomycin-sorbitol and lactulose in the treatment of acute portal-systemic encephalopathy. A controlled, double-blind clinical trial. *Am J Dig Dis* 1978;23:398-406.
120. Baser O. Too much ado about propensity score models? Comparing methods of propensity score matching. *Value Health* 2006;9:377-85.
121. Austin PC. Balance diagnostics for comparing the distribution of baseline covariates between treatment groups in propensity-score matched samples. *Stat Med* 2009;28:3083-107.
122. Hassanein TI, Tofteng F, Brown RS, et al. Randomized controlled study of extracorporeal albumin dialysis for hepatic encephalopathy in advanced cirrhosis. *Hepatology* 2007;46:1853-62.
123. Heemann U, Treichel U, Looock J, et al. Albumin dialysis in cirrhosis with superimposed acute liver injury: A prospective, controlled study. *Hepatology* 2002;36:949-58.
124. Bañares R, Nevens F, Larsen FS, et al. Extracorporeal albumin dialysis with the molecular adsorbent recirculating system in acute-on-chronic liver failure: The RELIEF trial. *Hepatology* 2013;57:1153-62.
125. Antoniadis CG, Berry PA, Wendon JA, Vergani D. The importance of immune dysfunction in determining outcome in acute liver failure. *Journal of Hepatology* 2008;49:845-61.

## CHAPTER 4—Summary

## **4.1 Summary of Findings**

This thesis research aimed to develop a comprehensive description of acute liver failure (ALF), focusing on clinical interventions and associated outcomes in North American ALF patients. As acetaminophen (APAP) toxicity represents the most common ALF etiology, this thesis described the natural history of APAP-ALF through the evaluation of changes in clinical interventions, psychosocial profile, and important clinical outcomes over time. Using a large multicentre APAP-ALF patient cohort, 21-day transplant-free survival (TFS) significantly increased from 61.7% during 1998-2007 to 69.8% during 2008-2018. Similarly, incidence of intracranial hypertension and 21-day mortality secondary to cerebral edema significantly decreased from 51.5% to 29.9% and from 11.6% to 4.5%, respectively, over the same time intervals. Notably, these findings occurred in association with increased use of early continuous renal replacement therapy (CRRT; from 7.6% to 22.2% during first 7 days), with use of CRRT found to be significantly associated with improved 21-day TFS (OR 1.62; 95% CI: 1.07-2.44;  $p=0.023$ ). Overdose intentionality and presence of psychiatric comorbidities were not found to be independently associated with 21-day TFS.

Furthermore, this thesis aimed to summarize evidence regarding the potential role of extracorporeal liver support (ECLS) systems in the management of ALF. Of these systems, only high-volume plasmapheresis has previously been found to confer a clinically and statistically significant TFS advantage in ALF patients.<sup>100</sup> In the case of the molecular adsorbent recirculating system (MARS), the FULMAR controlled trial failed to find an associated mortality benefit following intention-to-treat analysis; though, high rates

of early liver transplantation (LT) likely confounded the assessment of MARS.<sup>96</sup> Currently, there remains no evidence-based recommendation for the use of MARS in ALF. Using what we believe to be the largest cohort of ALF patients receiving MARS therapy, this thesis described the role of MARS in all-etiology ALF and its implications on TFS. Following propensity score (PS) matching to identify comparable standard medical therapy (SMT) control patients, MARS-treated patients displayed similar 21-day TFS (51.9%) compared to SMT controls (52.9%). After adjusting for covariates reflecting likelihood of MARS treatment, use of MARS was not associated with increased odds of 21-day TFS over SMT alone (*Main Model*; OR 1.60; 95% CI: 0.93-2.76; p=0.093). In several sensitivity analyses, MARS treatment was independently associated with improved 21-day TFS: following addition of PS (MARS OR 1.90; p=0.030), and PS, mechanical ventilation, and development of grade 3/4 HE (MARS OR 1.91; p=0.029) to the *Main Model*, and in a model adjusting for ALF etiology and PS (MARS OR 1.86; p=0.033). In line with previous trials, MARS therapy was found to be associated with significant improvements in biochemical and hemodynamic parameters.<sup>95-97</sup>

#### **4.2 Implications and Future Directions**

The number of patients dying from ALF remains disappointingly high. Given the severity of illness and scarcity of donor organs available for LT, critical care management of these patients must promote increased spontaneous survival or bridging to successful LT. As this research is observational, it may comment only on associations. Despite this, use of CRRT was associated with increased TFS in APAP-ALF, and MARS therapy, compared

with SMT, was associated with a trend towards increased TFS in all-etiology ALF. Traditional guidelines for the initiation of renal replacement therapy in critically ill patients are applicable to those with ALF. Future controlled trials should consider evaluating timing of CRRT administration to establish ALF-specific guidelines. Regarding MARS, further research incorporating a more homogenous control patient cohort is required to explore its potential TFS role in important ALF subgroups (i.e. APAP-ALF patients, avoid enrollment of patients with futile prognosis). Finally, future standardization of MARS and SMT protocols should be considered in order to avoid potential confounding by cointerventions in the assessment of MARS.



### **4.3 References**

95. Novelli G, Rossi M, Pretagostini R, et al. MARS (molecular adsorbent recirculating system): experience in 34 cases of acute liver failure. *Liver* 2002;22:43-7.
96. Saliba F, Camus C, Durand F, Mathurin P, et al. Albumin dialysis with a noncell artificial liver support device in patients with acute liver failure: a randomized, controlled trial. *Annals of Internal Medicine* 2013;159:522-31.
97. Schmidt LE, Wang LP, Hansen BA, Larsen FS. Systemic hemodynamic effects of treatment with the molecular adsorbents recirculating system in patients with hyperacute liver failure: a prospective controlled trial. *Liver Transplantation* 2003;9:290-7.
100. Larsen FS, Schmidt LE, Bernsmeier C, et al. High-volume plasma exchange in patients with acute liver failure: an open randomised controlled trial. *Journal of Hepatology* 2016;64:69-78.

## REFERENCES

1. Stravitz RT, Lee WM. Acute liver failure. *Lancet* 2019;394:869-81.
2. O'Grady JG, Williams R. Classification of acute liver failure. *Lancet* 1993;342:743.
3. Bernal W, Wendon J. Acute liver failure. *N Engl J Med* 2013;369:2525-34.
4. Lee WM. Acute liver failure. *Semin Respir Crit Care Med* 2012;33:36-45.
5. Ware AJ, D'Agostino AN, Combes B. Cerebral edema: a major complication of massive hepatic necrosis. *Gastroenterology* 1971;61:877-84.
6. Bernal W, Wendon J. Acute liver failure; clinical features and management. *Eur J Gastroenterol Hepatol* 1999;11:977-84.
7. Reuben A, Tillman H, Fontana RJ, et al. Outcomes in adults with acute liver failure between 1998 and 2013: an observational cohort study. *Ann Intern Med* 2016;164:724-32.
8. O'Grady JG, Wendon J, Tan KC, et al. Liver transplantation after paracetamol overdose. *BMJ* 1991;303:221-3.
9. Lee KC, Stadlbauer V, Jalan R. Extracorporeal liver support devices for listed patients. *Liver Transpl* 2016;22:839-48.
10. Katarey D, Jalan R. Update on extracorporeal liver support. *Curr Opin Crit Care* 2020;26:180-5.
11. Jalan R, Sen S, Williams R. Prospects for extracorporeal liver support. *Gut* 2004;53:890-8.

12. Trey C, Davidson CS. The management of fulminant hepatic failure. *Prog Liver Dis* 1970;3:282-98.
13. O'Grady JG, Schalm SW, Williams R. Acute liver failure: redefining the syndromes. *The Lancet* 1993;342:273-5.
14. Wendon J, Cordoba J, Dhawan A, et al. EASL clinical practical guidelines on the management of acute (fulminant) liver failure. *J Hepatol* 2017;66:1047-81.
15. Dhiman RK, Seth AK, Jain S, Chawla YK, Dilawari JB. Prognostic evaluation of early indicators in fulminant hepatic failure by multivariate analysis. *Dig Dis Sci* 1998;43:1311-6.
16. Bernal W, Auzinger G, Dhawan A, Wendon J. Acute liver failure. *The Lancet* 2010;376:190-201.
17. Ostapowicz G, Fontana RJ, Schiodt FV, et al. Results of a prospective study of acute liver failure at 17 tertiary care centers in the United States. *Ann Intern Med* 2002;137:947-54.
18. Bernuau J, Rueff B, Benhamou JP. Fulminant and subfulminant liver failure: definitions and causes. *Semin Liver Dis* 1986;6:97-106.
19. Mochida S, Nakayama N, Matsui A, Nagoshi S, Fujiwara K. Re-evaluation of the guideline published by the Acute Liver Failure Study Group of Japan in 1996 to determine the indications of liver transplantation in patients with fulminant hepatitis. *Hepatol Res* 2008;38:970-9.
20. Tandon BN, Bernuau J, O'Grady J, et al. Recommendations of the International Association for the Study of the Liver subcommittee on nomenclature of acute and subacute liver failure. *J Gastroenterol Hepatol* 1999;14:403-4.

21. Wlodzimirow KA, Eslami S, Abu-Hanna A, Nieuwoudt M, Chamuleau RA. Systematic review: acute liver failure - one disease, more than 40 definitions. *Aliment Pharmacol Ther* 2012;35:1245-56.
22. Lee WM, Stravitz RT, Larson AM. Introduction to the revised American Association for the Study of Liver Diseases position paper on acute liver failure 2011. *Hepatology* 2012;55:965-7.
23. Bernal W, Hyyrylainen A, Gera A, et al. Lessons from look-back in acute liver failure? A single centre experience of 3300 patients. *J Hepatol* 2013;59:74-80.
24. Bernal W. Changing patterns of causation and the use of transplantation in the United Kingdom. *Semin Liver Dis* 2003;23:227-37.
25. Lee WM. Acute liver failure in the United States. *Semin Liver Dis* 2003;23:217-26.
26. Lee WM. Acetaminophen (APAP) hepatotoxicity-isn't it time for APAP to go away? *J Hepatol* 2017;67:1324-31.
27. Larson AM, Polson J, Fontana RJ, et al. Acetaminophen-induced acute liver failure: results of a United States multicenter, prospective study. *Hepatology* 2005;42:1364-72.
28. Zimmerman HJ, Maddrey WC. Acetaminophen (paracetamol) hepatotoxicity with regular intake of alcohol: analysis of instances of therapeutic misadventure. *Hepatology* 1995;22:767-73.
29. Maddrey WC. Hepatic effects of acetaminophen. Enhanced toxicity in alcoholics. *J Clin Gastroenterol* 1987;9:180-5.

30. Whitcomb DC, Block GD. Association of acetaminophen hepatotoxicity with fasting and ethanol use. *JAMA* 1994;272:1845-50.
31. Schiodt FV, Rochling FA, Casey DL, Lee WM. Acetaminophen toxicity in an urban county hospital. *N Engl J Med* 1997;337:1112-7.
32. Harrison PM, Wendon JA, Gimson AE, Alexander GJ, Williams R. Improvement by acetylcysteine of hemodynamics and oxygen transport in fulminant hepatic failure. *N Engl J Med* 1991;324:1852-7.
33. Keays R, Harrison PM, Wendon JA, et al. Intravenous acetylcysteine in paracetamol induced fulminant hepatic failure: a prospective controlled trial. *BMJ* 1991;303:1026-9.
34. Lee WM, Hynan LS, Rossaro L, et al. Intravenous N-acetylcysteine improves transplant-free survival in early stage non-acetaminophen acute liver failure. *Gastroenterology* 2009;137:856-64, 64 e1.
35. Simpson KJ, Bates CM, Henderson NC, et al. The utilization of liver transplantation in the management of acute liver failure: comparison between acetaminophen and non-acetaminophen etiologies. *Liver Transpl* 2009;15:600-9.
36. Jones A. Over-the-counter analgesics: a toxicology perspective. *Am J Ther* 2002;9:245-57.
37. Nourjah P, Ahmad SR, Karwoski C, Willy M. Estimates of acetaminophen (paracetamol)-associated overdoses in the United States. *Pharmacoepidemiol Drug Saf* 2006;15:398-405.

38. Mitchell JR, Jollow DJ, Potter WZ, Davis DC, Gillette JR, Brodie BB. Acetaminophen-induced hepatic necrosis. I. Role of drug metabolism. *J Pharmacol Exp Ther* 1973;187:185-94.
39. Lancaster EM, Hiatt JR, Zarrinpar A. Acetaminophen hepatotoxicity: an updated review. *Arch Toxicol* 2015;89:193-9.
40. Bunchorntavakul C, Reddy KR. Acetaminophen-related hepatotoxicity. *Clin Liver Dis* 2013;17:587-607, viii.
41. Chung RT, Stravitz RT, Fontana RJ, et al. Pathogenesis of liver injury in acute liver failure. *Gastroenterology* 2012;143:e1-e7.
42. Nanchal R, Subramanian R, Karvellas CJ, et al. Guidelines for the management of adult acute and acute-on-chronic liver failure in the ICU: cardiovascular, endocrine, hematologic, pulmonary, and renal considerations. *Critical Care Medicine* 2020;48:e173-e91.
43. Wijdicks EF. Hepatic encephalopathy. *N Engl J Med* 2016;375:1660-70.
44. Albrecht J, Norenberg MD. Glutamine: a Trojan horse in ammonia neurotoxicity. *Hepatology* 2006;44:788-94.
45. Butterworth RF, Giguere JF, Michaud J, Lavoie J, Layrargues GP. Ammonia: key factor in the pathogenesis of hepatic encephalopathy. *Neurochem Pathol* 1987;6:1-12.
46. Trovato FM, Rabinowich L, McPhail MJW. Update on the management of acute liver failure. *Curr Opin Crit Care* 2019;25:157-64.
47. Murphy N, Auzinger G, Bernel W, Wendon J. The effect of hypertonic sodium chloride on intracranial pressure in patients with acute liver failure. *Hepatology* 2004;39:464-70.

48. Bernal W, Murphy N, Brown S, et al. A multicentre randomized controlled trial of moderate hypothermia to prevent intracranial hypertension in acute liver failure. *J Hepatol* 2016;65:273-9.
49. Karvellas CJ, Todd Stravitz R, Battenhouse H, Lee WM, Schilsky ML, US Acute Liver Failure Study Group. Therapeutic hypothermia in acute liver failure: a multicenter retrospective cohort analysis. *Liver Transpl* 2015;21:4-12.
50. Blei AT, Olafsson S, Webster S, Levy R. Complications of intracranial pressure monitoring in fulminant hepatic failure. *Lancet* 1993;341:157-8.
51. Vaquero J, Fontana RJ, Larson AM, et al. Complications and use of intracranial pressure monitoring in patients with acute liver failure and severe encephalopathy. *Liver Transpl* 2005;11:1581-9.
52. Karvellas CJ, Fix OK, Battenhouse H, et al. Outcomes and complications of intracranial pressure monitoring in acute liver failure: a retrospective cohort study. *Crit Care Med* 2014;42:1157-67.
53. Canalese J, Gimson AE, Davis C, Mellon PJ, Davis M, Williams R. Controlled trial of dexamethasone and mannitol for the cerebral oedema of fulminant hepatic failure. *Gut* 1982;23:625-9.
54. Wendon J, Lee W. Encephalopathy and cerebral edema in the setting of acute liver failure: pathogenesis and management. *Neurocrit Care* 2008;9:97-102.
55. Bernal W, Hall C, Karvellas CJ, Auzinger G, Sizer E, Wendon J. Arterial ammonia and clinical risk factors for encephalopathy and intracranial hypertension in acute liver failure. *Hepatology* 2007;46:1844-52.

56. Cardoso FS, Gottfried M, Tujios S, Olson JC, Karvellas CJ, US Acute Liver Failure Study Group. Continuous renal replacement therapy is associated with reduced serum ammonia levels and mortality in acute liver failure. *Hepatology* 2018;67:711-20.
57. Tujios SR, Hynan LS, Vazquez MA, et al. Risk factors and outcomes of acute kidney injury in patients with acute liver failure. *Clin Gastroenterol Hepatol* 2015;13:352-9.
58. Slack AJ, Auzinger G, Willars C, et al. Ammonia clearance with haemofiltration in adults with liver disease. *Liver Int* 2014;34:42-8.
59. Warrillow S, Fisher C, Bellomo R. Correction and control of hyperammonemia in acute liver failure: the impact of continuous renal replacement timing, intensity, and duration. *Crit Care Med* 2020;48:218-24.
60. Rajaram P, Subramanian R. Management of acute liver failure in the intensive care unit setting. *Clin Liver Dis* 2018;22:403-8.
61. Rhodes A, Evans LE, Alhazzani W, et al. Surviving sepsis campaign: international guidelines for management of sepsis and septic shock: 2016. *Crit Care Med* 2017;45:486-552.
62. Eefsen M, Dethloff T, Frederiksen HJ, Hauerberg J, Hansen BA, Larsen FS. Comparison of terlipressin and noradrenalin on cerebral perfusion, intracranial pressure and cerebral extracellular concentrations of lactate and pyruvate in patients with acute liver failure in need of inotropic support. *J Hepatol* 2007;47:381-6.
63. Harry R, Auzinger G, Wendon J. The clinical importance of adrenal insufficiency in acute hepatic dysfunction. *Hepatology* 2002;36:395-402.



64. Harry R, Auzinger G, Wendon J. The effects of supraphysiological doses of corticosteroids in hypotensive liver failure. *Liver Int* 2003;23:71-7.
65. Etogo-Asse FE, Vincent RP, Hughes SA, et al. High density lipoprotein in patients with liver failure; relation to sepsis, adrenal function and outcome of illness. *Liver Int* 2012;32:128-36.
66. Karkhanis J, Verna EC, Chang MS, et al. Steroid use in acute liver failure. *Hepatology* 2014;59:612-21.
67. O'Riordan A, Brummell Z, Sizer E, et al. Acute kidney injury in patients admitted to a liver intensive therapy unit with paracetamol-induced hepatotoxicity. *Nephrol Dial Transplant* 2011;26:3501-8.
68. Waring WS, Jamie H, Leggett GE. Delayed onset of acute renal failure after significant paracetamol overdose: a case series. *Hum Exp Toxicol* 2010;29:63-8.
69. Polson J, Lee WM. AASLD position paper: the management of acute liver failure. *Hepatology* 2005;41:1179-97.
70. Bagshaw SM, Wald R. Acute kidney injury: timing of renal replacement therapy in AKI. *Nat Rev Nephrol* 2016;12:445-6.
71. Davenport A, Will EJ, Davidson AM. Improved cardiovascular stability during continuous modes of renal replacement therapy in critically ill patients with acute hepatic and renal failure. *Crit Care Med* 1993;21:328-38.
72. Fontana RJ, Ellerbe C, Durkalski VE, et al. Two-year outcomes in initial survivors with acute liver failure: results from a prospective, multicentre study. *Liver Int* 2015;35:370-80.

73. Germani G, Theocharidou E, Adam R, et al. Liver transplantation for acute liver failure in Europe: outcomes over 20 years from the ELTR database. *J Hepatol* 2012;57:288-96.
74. McPhail MJ, Farne H, Senvar N, Wendon JA, Bernal W. Ability of King's College Criteria and Model for End-Stage Liver Disease scores to predict mortality of patients with acute liver failure: a meta-analysis. *Clin Gastroenterol Hepatol* 2016;14:516-25 e5; quiz e43-e45.
75. Koch DG, Tillman H, Durkalski V, Lee WM, Reuben A. Development of a model to predict transplant-free survival of patients with acute liver failure. *Clin Gastroenterol Hepatol* 2016;14:1199-206 e2.
76. O'Grady JG, Alexander GJ, Hayllar KM, Williams R. Early indicators of prognosis in fulminant hepatic failure. *Gastroenterology* 1989;97:439-45.
77. Bailey B, Amre DK, Gaudreault P. Fulminant hepatic failure secondary to acetaminophen poisoning: a systematic review and meta-analysis of prognostic criteria determining the need for liver transplantation. *Crit Care Med* 2003;31:299-305.
78. Renner EL. How to decide when to list a patient with acute liver failure for liver transplantation? Clichy or King's College criteria, or something else? *J Hepatol* 2007;46:554-7.
79. Nyberg SL. Bridging the gap: Advances in artificial liver support. *Liver Transplantation* 2012;18:S10-S4.
80. Larsen FS. Artificial liver support in acute and acute-on-chronic liver failure. *Curr Opin Crit Care* 2019;25:187-91.

81. Allen JW, Hassanein T, Bhatia SN. Advances in bioartificial liver devices. *Hepatology* 2001;34:447-55.
82. Cao S, Esquivel CO, Keeffe EB. New approaches to supporting the failing liver. *Annual Review of Medicine* 1998:85-94.
83. Park J-k, Lee D-h. Bioartificial liver systems: current status and future perspective. *Journal of Bioscience and Bioengineering* 2005;99:311-9.
84. Mitzner S, Klammt S, Stange J, Schmidt R. Albumin regeneration in liver support—comparison of different methods. *Therapeutic Apheresis and Dialysis* 2006;10:108-17.
85. Khamri W, Abeles RD, Hou TZ, et al. Increased expression of cytotoxic T-lymphocyte-associated protein 4 by T cells, induced by B7 in sera, reduces adaptive immunity in patients with acute liver failure. *Gastroenterology* 2017;153:263-76 e8.
86. Stange J, Ramlow W, Mitzner S, Schmidt R, Klinkmann H. Dialysis against a recycled albumin solution enables the removal of albumin-bound toxins. *Artificial Organs* 1993;17:809-13.
87. Karvellas CJ, Bagshaw SM, Mcdermid RC, Stollery DE, Gibney RT. Acetaminophen-induced acute liver failure treated with single-pass albumin dialysis: report of a case. *The International Journal of Artificial Organs* 2008;31:450-5.
88. Falkenhagen D, Strobl W, Vogt G, et al. Fractionated plasma separation and adsorption system: a novel system for blood purification to remove albumin bound substances. *Artificial Organs* 1999;23:81-6.

89. Winters JL. Plasma exchange: concepts, mechanisms, and an overview of the American Society for Apheresis guidelines. *ASH Education Program Book* 2012;2012:7-12.
90. Sussman NL, Chong MG, Koussayer T, et al. Reversal of fulminant hepatic failure using an extracorporeal liver assist device. *Hepatology* 1992;16:60-5.
91. Ellis AJ, Hughes RD, Wendon JA, et al. Pilot-controlled trial of the extracorporeal liver assist device in acute liver failure. *Hepatology* 1996;24:1446-51.
92. Demetriou AA, Brown RS, Busuttil RW, et al. Prospective, randomized, multicenter, controlled trial of a bioartificial liver in treating acute liver failure. *Annals of Surgery* 2004;239:660-70.
93. Stange J, Mitzner SR, Risler T, et al. Molecular adsorbent recycling system (MARS): clinical results of a new membrane-based blood purification system for bioartificial liver support. *Artif Organs* 1999;23:319-30.
94. Mitzner SR, Stange J, Klammt S, et al. Improvement of hepatorenal syndrome with extracorporeal albumin dialysis mars: Results of a prospective, randomized, controlled clinical trial. *Liver Transplantation* 2000;6:277-86.
95. Novelli G, Rossi M, Pretagostini R, et al. MARS (molecular adsorbent recirculating system): experience in 34 cases of acute liver failure. *Liver* 2002;22:43-7.
96. Saliba F, Camus C, Durand F, Mathurin P, et al. Albumin dialysis with a noncell artificial liver support device in patients with acute liver failure: a randomized, controlled trial. *Annals of Internal Medicine* 2013;159:522-31.
97. Schmidt LE, Wang LP, Hansen BA, Larsen FS. Systemic hemodynamic effects of treatment with the molecular adsorbents recirculating system in patients with

hyperacute liver failure: a prospective controlled trial. *Liver Transplantation* 2003;9:290-7.

98. Larsen FS, Ejlersen E, Hansen BA, Mogensen T, Tygstrup N, Secher NH. Systemic vascular resistance during high-volume plasmapheresis in patients with fulminant hepatic failure: relationship with oxygen consumption. *European journal of gastroenterology & hepatology* 1995;7:887-92.

99. Larsen FS, Hansen BA, Ejlersen E, et al. Cerebral blood flow, oxygen metabolism and transcranial Doppler sonography during high-volume plasmapheresis in fulminant hepatic failure. *European journal of gastroenterology & hepatology* 1996;8:261-5.

100. Larsen FS, Schmidt LE, Bernsmeier C, et al. High-volume plasma exchange in patients with acute liver failure: an open randomised controlled trial. *Journal of Hepatology* 2016;64:69-78.

101. Thompson J, Jones N, Al-Khafaji A, et al. Extracorporeal cellular therapy (ELAD) in severe alcoholic hepatitis: a multinational, prospective, controlled, randomized trial. *Liver Transplantation* 2018;24:380-93.

102. Stravitz RT, Kramer AH, Davern T, et al. Intensive care of patients with acute liver failure: recommendations of the U.S. Acute Liver Failure Study Group. *Crit Care Med* 2007;35:2498-508.

103. Karvellas CJ, Safinia N, Auzinger G, et al. Medical and psychiatric outcomes for patients transplanted for acetaminophen-induced acute liver failure: a case-control study. *Liver Int* 2010;30:826-33.

104. Pezzia C, Sanders C, Welch S, Bowling A, Lee WM, Acute Liver Failure Study Group. Psychosocial and behavioral factors in acetaminophen-related acute liver failure and liver injury. *J Psychosom Res* 2017;101:51-7.
105. Prescott LF, Critchley JA. The treatment of acetaminophen poisoning. *Annu Rev Pharmacol Toxicol* 1983;23:87-101.
106. Hamlyn AN, Douglas AP, James O. The spectrum of paracetamol (acetaminophen) overdose: clinical and epidemiological studies. *Postgrad Med J* 1978;54:400-4.
107. Simmons OL, Meinzer C, Rule J, Lee WM, US Acute Liver Failure Study Group. Liver transplantation for acetaminophen-induced acute liver failure: role of psychiatric comorbidity in listing decisions and outcomes. *Dig Dis Sci* 2019.
108. Koch DG, Speiser JL, Durkalski V, et al. The natural history of severe acute liver injury. *Am J Gastroenterol* 2017;112:1389-96.
109. Karvellas CJ, Speiser JL, Tremblay M, Lee WM, Rose CF, Group USALFS. Elevated FABP1 serum levels are associated with poorer survival in acetaminophen-induced acute liver failure. *Hepatology* 2017;65:938-49.
110. Blei AT. Medical therapy of brain edema in fulminant hepatic failure. *Hepatology* 2000;32:666-9.
111. Fujiwara K, Mochida S, Matsui A, et al. Fulminant hepatitis and late onset hepatic failure in Japan. *Hepatol Res* 2008;38:646-57.
112. Oketani M, Ido A, Nakayama N, et al. Etiology and prognosis of fulminant hepatitis and late-onset hepatic failure in Japan: summary of the annual nationwide survey between 2004 and 2009. *Hepatol Res* 2013;43:97-105.

113. Bhatia V, Singh R, Acharya SK. Predictive value of arterial ammonia for complications and outcome in acute liver failure. *Gut* 2006;55:98-104.
114. Clemmesen JO, Larsen FS, Kondrup J, Hansen BA, Ott P. Cerebral herniation in patients with acute liver failure is correlated with arterial ammonia concentration. *Hepatology* 1999;29:648-53.
115. Davenport A. Continuous renal replacement therapies in patients with acute neurological injury. *Semin Dial* 2009;22:165-8.
116. Davenport A. Is there a role for continuous renal replacement therapies in patients with liver and renal failure? *Kidney International* 1999;56:S62-S6.
117. Connors AF, Jr. Pitfalls in estimating the effect of interventions in the critically ill using observational study designs. *Crit Care Med* 2001;29:1283-4.
118. Banayosy AE, Kizner L, Schueler V, Bergmeier S, Cobaugh D, Koerfer R. First use of the molecular adsorbent recirculating system technique on patients with hypoxic liver failure after cardiogenic shock. *ASAIO Journal* 2004;50:332-7.
119. Atterbury CE, Maddrey WC, Conn HO. Neomycin-sorbitol and lactulose in the treatment of acute portal-systemic encephalopathy. A controlled, double-blind clinical trial. *Am J Dig Dis* 1978;23:398-406.
120. Baser O. Too much ado about propensity score models? Comparing methods of propensity score matching. *Value Health* 2006;9:377-85.
121. Austin PC. Balance diagnostics for comparing the distribution of baseline covariates between treatment groups in propensity-score matched samples. *Stat Med* 2009;28:3083-107.

122. Hassanein TI, Tofteng F, Brown RS, et al. Randomized controlled study of extracorporeal albumin dialysis for hepatic encephalopathy in advanced cirrhosis. *Hepatology* 2007;46:1853-62.
123. Heemann U, Treichel U, Looock J, et al. Albumin dialysis in cirrhosis with superimposed acute liver injury: A prospective, controlled study. *Hepatology* 2002;36:949-58.
124. Bañares R, Nevens F, Larsen FS, et al. Extracorporeal albumin dialysis with the molecular adsorbent recirculating system in acute-on-chronic liver failure: The RELIEF trial. *Hepatology* 2013;57:1153-62.
125. Antoniadou CG, Berry PA, Wendon JA, Vergani D. The importance of immune dysfunction in determining outcome in acute liver failure. *Journal of Hepatology* 2008;49:845-61.