

Impact of Interface Controls on the Steady-State Stability of Inverter-Based Distributed Generators

Xiaoyu Wang, *Student Member, IEEE*, Waldir Freitas, *Member, IEEE*, Wilsun Xu, *Fellow, IEEE*, and Venkata Dinavahi, *Member, IEEE*

Abstract—This paper presents a study about the impact of different inverter interface controls on the steady-state stability of inverter-based distributed generators (DG) in the presence of positive feedback anti-islanding schemes. The impact of the constant power controller and the constant current controller on the DG system steady-state stability is compared. The Sandia Frequency Shift (SFS) anti-islanding control is included in the inverter controllers. The comparison results show that in grid parallel mode the constant current-controlled DG can transfer more power to the connected power system when the local load level is low. However, the constant power-controlled DG has higher power transfer capability for heavy load situations.

Index Terms— Distributed generation, inverter, islanding detection, positive feedback, steady-state stability.

I. INTRODUCTION

WITH the development of distributed generation (DG) a lot of anti-islanding methods have been proposed and tested according to the interconnection requirements of distributed generators to power distribution systems [1]. However, many DG-to-DG and DG-to-system interaction issues are unique and have not been fully explored when the anti-islanding schemes are considered. One of the concerns associated with high penetration of DG is the impact of the interface controls on the interconnection performance of DG systems.

In inverter-based DG applications, different inverter interface control strategies may have distinctive impact on the DG operation when it is operated in grid parallel mode [2]- [4]. The impact will be more complex if the positive feedback anti-islanding methods are embedded in DG. Positive feedback anti-islanding scheme is a general concept that uses the deviations of frequency and voltage from normal values as positive feedback signals to influence the operation of the generator. Because of the positive feedback, the inverter always attempts to destabilize the interconnected DG system. If a DG is connected to a strong utility system, the destabilizing force

has a negligible impact and an inverter can operate without difficulties. If the DG is islanded, the feedback can destabilize the generator easily. Such generator behaviors facilitate the detection of islanding conditions. Positive feedback anti-islanding control is resident in the inverter and it will inevitably interact with the main inverter interface controls such as the constant power control and the constant current control.

The objective of this paper is to investigate the characteristics of such interactions from the stability perspective since the positive feedback anti-islanding control is a destabilizing force which may have a negative impact on the stability of an interconnected DG system. The modal analysis of the test DG system is employed to study the different effects of the positive feedback control on the DG system steady-state stability when it works together with the constant power controller and the constant current controller. In this paper, the Sandia Frequency Shift (SFS) scheme applied to three-phase inverters is selected as the representative positive feedback method for the investigation.

The paper is organized as follows. In Section II, the studied DG system is presented. The inverter interface control models including the anti-islanding control are also introduced in this section. The steady-state stability analysis is conducted in Section III. Section IV summarizes the conclusions.

II. DG SYSTEM MODEL

Fig. 1 shows a single-line equivalent circuit of a three-phase, grid-connected, voltage controlled inverter-based DG system. In this figure, an inverter-based distributed generator is connected to a distribution power system. R_0 and L_0 are the resistance and the inductance of the power system line, respectively. L_s is the inductance of the inverter filter. The output power of the DG is $P+jQ$ and $\Delta P+j\Delta Q$ is the imbalance power between the parallel RLC load and the DG. CB is the circuit breaker at the interconnection point.

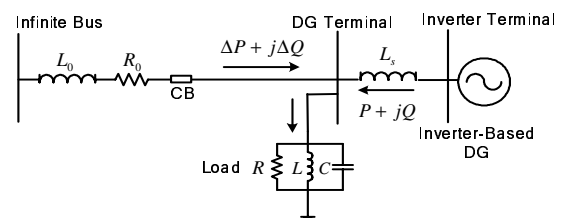

Fig. 1. Single-line diagram of an inverter-based DG system.

This research is supported by Natural Resources Canada through the Technology and Innovation Program as part of the Climate Action Plan for Canada.

X. Y. Wang, W. Xu, and V. Dinavahi are with the Department of Electrical and Computer Engineering, University of Alberta, Edmonton, AB, T6G 2V4 Canada (e-mails: wangxy@ece.ualberta.ca, wxu@ualberta.ca, dinavahi@ece.ualberta.ca).

W. Freitas is with the Department of Electrical Energy Systems, State University of Campinas, C.P. 6101, 13083-852, Campinas, Brazil (e-mail: walmir@ieec.org).

The main system parameters are listed in Table I.

TABLE I
THREE-PHASE MODEL PARAMETERS

Parameters	Value
V_{base}	170 (V)
S_{base}	10000 (W)
R_o	0.2 (ohm)
L_o	0.796 (mH)
L_s	1 (mH)
R	4.32 (ohm)
L	6.4 (mH)
C	1.1 (mF)

A. Inverter Model

The average model of a three-phase voltage source inverter (VSI) is set up for DG modeling [5]. In the average inverter model the pulse width-modulated (PWM) pattern generator, the DC source and the switching power electronics devices, such as insulated gate bipolar transistors (IGBTs), are replaced by ideal voltage sources which are controlled by the inverter controller.

B. SFS Model

SFS was originally proposed for single-phase inverters used in photovoltaic systems [6]. In this method, the inverter output current is distorted by adding a zero time segment in each semi-cycle. In the analytical analysis, the harmonic components of the inverter output current are neglected and only the fundamental part is considered [6], [7]. As a result, a positive feedback signal of the anti-islanding control is introduced to the phase angle of the inverter output current. The block diagram of phase angle control is shown in Fig. 2

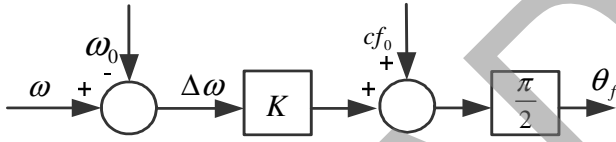

Fig. 2. Block diagram of SFS.

where ω is the inverter terminal voltage frequency which is measured by a three-phase phase-locked loop (PLL) and K is the positive feedback gain. cf_0 is the presetting chopping fraction when the voltage frequency is equal to the system base frequency ω_0 .

C. DG Interface Controller Models

SFS can readily be extended to three-phase systems. In this case, a phase angle transformation is used to realize the frequency shift, which is shown in Fig. 3(a) where the constant power controller is also displayed. The inverter dq reference currents i_{dref} and i_{qref} are obtained from the power regulator, in which P_{ref} and Q_{ref} are the inverter output active and reactive power references, respectively. Then, i_{dref} and i_{qref} are transformed to i_{dref}^* and i_{qref}^* by applying the transformation defined in (1):

$$\begin{bmatrix} i_{dref}^* \\ i_{qref}^* \end{bmatrix} = \begin{bmatrix} \cos \theta_f & -\sin \theta_f \\ \sin \theta_f & \cos \theta_f \end{bmatrix} \begin{bmatrix} i_{dref} \\ i_{qref} \end{bmatrix} \quad (1)$$

Then, i_{dref}^* and i_{qref}^* are set as the new current references in the inverter current regulator where v_d , v_q and i_d , i_q are the DG terminal voltages and the inverter output currents, respectively. The outputs of the current regulators v_{sd} and v_{sq} are the inverter terminal voltages. The constant current controller with the SFS control is shown in Fig. 3(b).

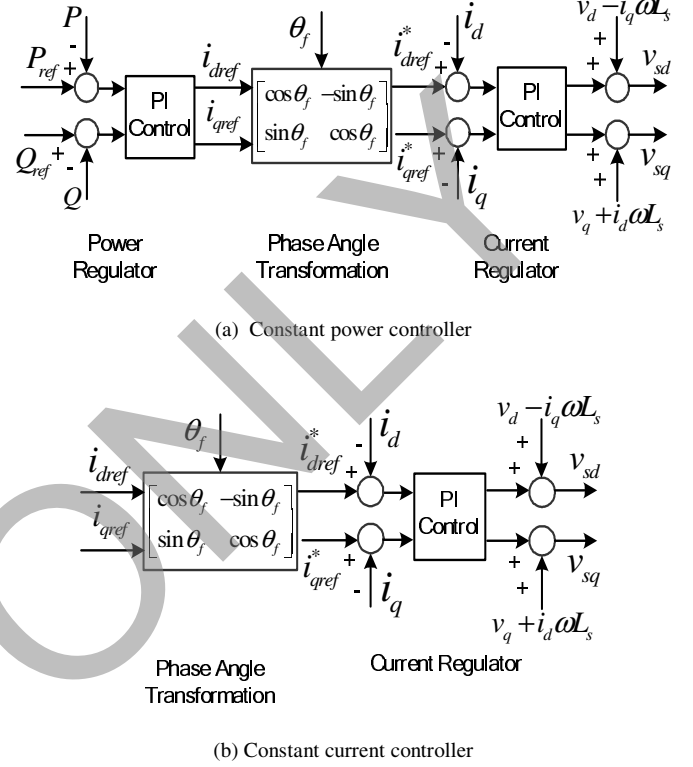

Fig. 3. Block diagram of the constant power controller and the constant current controller equipped with the SFS scheme

III. IMPACT OF THE INVERTER INTERFACE CONTROLS ON DG SYSTEM STABILITY

The inverter model including the PLL model [8], the interface controller model with the SFS control, the network and the DG local load model are connected to get the complete model for the system in Fig. 1. Two small-signal models of the DG system are derived from the complete model. The first one is for the system with the constant power control and the second one is for the constant current-controlled inverter. The steady-state stability of the DG system is studied through the modal analysis.

Fig. 4 shows the root loci of the eigenvalues for the constant power-controlled DG system. It is obtained by changing the inverter output power and fixing the SFS control parameters K and cf_0 . One can see from the figure that when the DG output power is increased to some level a pair of conjugate eigenvalues will move from the left half-plane to the right half-plane, which results in loss of DG system stability. As a result, each K can be related to one DG output power limit value. The constant current-controlled DG has a similar characteristic. Fig. 5 shows the root loci of the eigenvalues for the constant current-controlled DG system. In this figure, the increasing of the DG output current leads to the system

instability. It is seen that each K is related to one DG output current limit value.

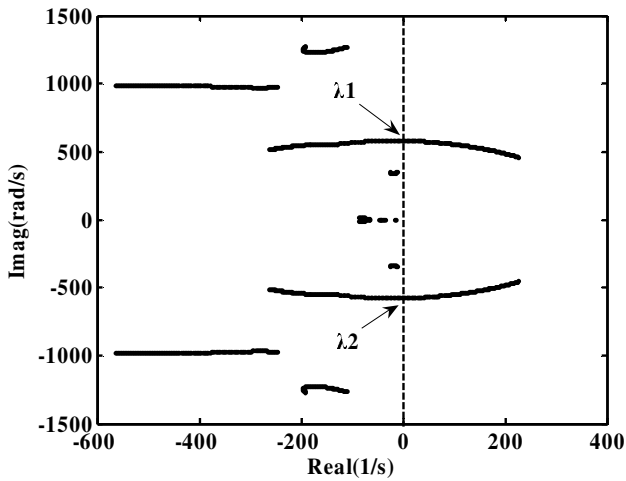

Fig. 4. Root loci of the constant power-controlled DG system eigenvalues ($K=0.01$, $cf_0=0$).

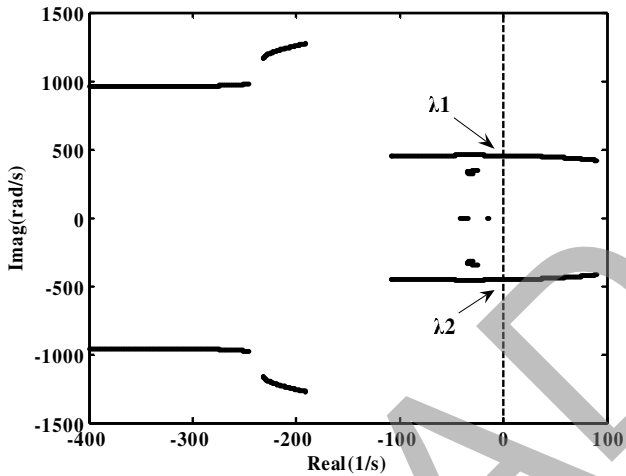

Fig. 5. Root loci of the constant current-controlled DG system eigenvalues ($K=0.01$, $cf_0=0.01$).

Based on the above observation, the *maximum power output limit versus positive feedback gain curve* (P - K curve) can be obtained. Then, this curve can be used to exhibit the DG power transfer capability with the different strength of the positive feedback. For the constant current-controlled DG system, the DG output current limit is related to K directly and the P - K curve is acquired by converting the current limit to the corresponding power limit through the steady-state power flow calculations. This facilitates the comparison of the performance of the two inverter interface controllers.

Fig. 6 displays the P - K curves for the DG system with the different controllers. cf_0 is set as zero for these curves. The resistance of the RLC load is 4.32Ω . The quality factor and the resonant frequency of the load are 1.8 and 60Hz, respectively. For this scenario, the DG output reactive power is zero, since, usually, the inverter is required to be operated with unity power factor [9]. It is noticed in Fig. 6 that the constant power-controlled DG has a lower output power limit than the constant current-controlled DG, which means the later DG can transfer more power to the grid. With the increasing of the

positive feedback gain value the difference between the two power limits is narrowed since both types of generators can transfer a very small amount of active power.

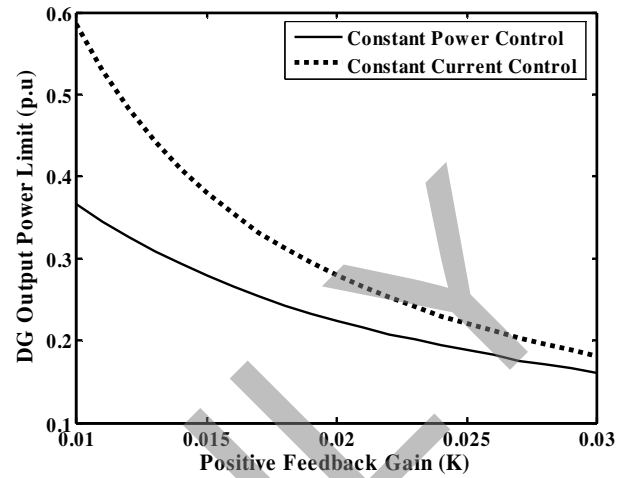

Fig. 6. P - K curves of the DG system ($R_L=4.32 \Omega$).

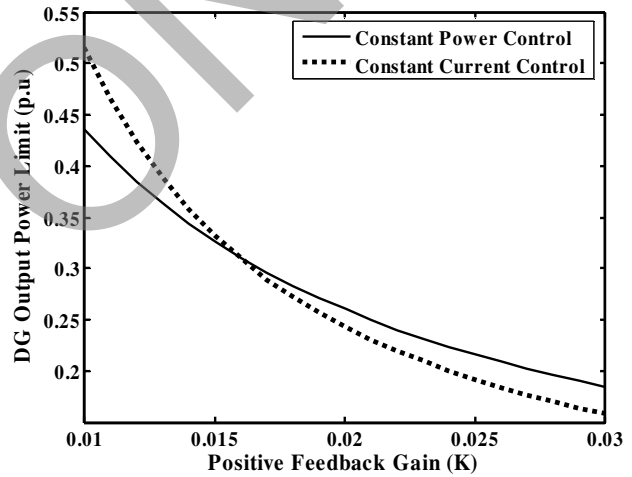

Fig. 7. P - K curves of the DG system ($R_L=2.16 \Omega$).

A different scenario is shown in Fig. 7 where resistance of the RLC load is 2.16Ω , which represents a relative higher load level. The other parameters of the DG system are the same with those in the previous scenario. It can be seen that when the positive feedback is weak the constant current-controlled DG still has a higher power transfer capability. However, the conclusion is reversed when K is increased. The constant power-controlled DG can produce more power with the strong positive feedback control. When the DG load level is raised further, the P - K curves are shown in Fig. 8 where R_L is set equal to 1.73Ω . In this scenario, the constant power-controlled DG has higher power transfer capability or larger steady-state stability margin than the constant current-controlled DG. And the power transfer capability gap between the two DGs is enlarged when the positive feedback anti-islanding control is strengthened.

Thus, from the above three scenarios one can see that the inverter-based DG has different power transfer capability when the inverter interface controls are different. This power transfer capability will decrease with the increasing of the positive

feedback gain of the anti-islanding control. In addition, the DG local load level also has the great effect on the DG power transfer limit.

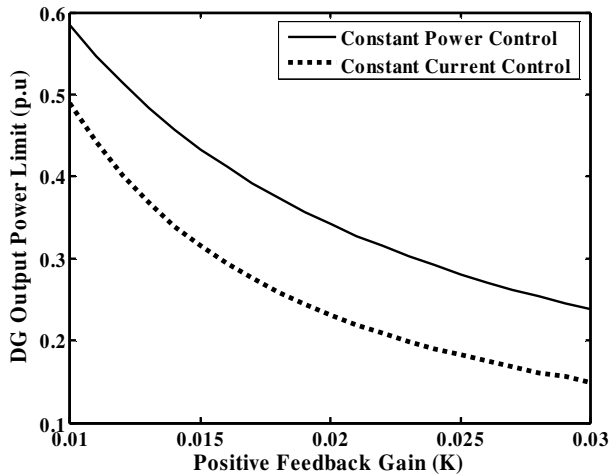

Fig. 8. P - K curves of the DG system ($R_L=1.73 \Omega$)

The sensitivity of cf_0 on the P - K curves for the two inverter controllers is also investigated. The results are shown in Fig. 9. cf_0 is changed from 0 to 0.06 for each controller. It can be observed that the DG power transfer capability for both controllers is reduced when cf_0 is larger. Moreover, the P - K curve change for the constant current-controlled DG is more sensitive to cf_0 variation in the DG system steady-state stability analysis.

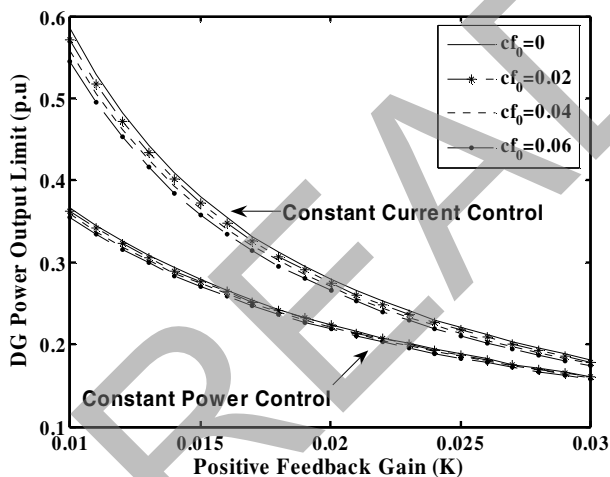

Fig. 9. P - K curves for different cf_0 ($R_L=4.32 \Omega$).

IV. CONCLUSIONS

The effect of the constant power controller and the constant current controller on the inverter-based DG system steady-state stability is different when the DG is connected to the grid in the presence of positive anti-islanding schemes. The interactions between the controllers and the positive feedback anti-islanding schemes make the difference more complex. This paper has investigated the influence of the different inverter interface controls on the DG power transfer capability by using the P - K curve, which includes impact of the positive feedback

anti-islanding control. It is concluded that the constant current-controlled DG has larger steady-state stability margin than the constant power-controlled DG when the DG local load level is low. However, the constant power-controlled DG can deliver more power at the high load level.

REFERENCES

- [1] W. Bower and M. E. Ropp, "Evaluation of islanding detection methods for photovoltaic utility-interactive power systems," International Energy Agency, Tech. Rep. Task V IEA-PVPS T5-09: 2002, Mar. 2002.
- [2] Z. Ye, A. Kolwalkar, Y. Zhang, P. Du and R. Walling, "Evaluation of anti-islanding schemes based on nondetection zone concept," *IEEE Trans. Power Electronics*, vol. 19, no. 5, pp. 1171-1176, Sept. 2004.
- [3] H. H. Zeineldin, E. F. El-Saadany and M. M. A. Salama, "Impact of DG interface control on islanding detection and nondetection zones," *IEEE Trans. Power Delivery*, vol. 21, no. 3, pp. 1515-1523, Jul. 2006.
- [4] S. H. Ko, S. R. Lee, H. Dehbonei and C. V. Nayar, "Application of voltage- and current-controlled voltage source inverters for distributed generation systems," *IEEE Trans. Energy Conversion*, vol. 21, no. 3, pp. 782-792, September 2006.
- [5] Z. Ye, R. Walling, L. Garces, R. Zhou, L. Li and T. Wang, "Study and development of anti-islanding control for grid-connected inverters," National Renewable Energy Laboratory, Tech. Rep. NREL/SR-560-36243, May 2004.
- [6] M. E. Ropp, M. Begovic, A. Rohatgi, "Analysis and performance assessment of the active frequency drift method of islanding prevention," *IEEE Trans. Energy Conversion*, vol. 14, no. 3, pp. 810-816, September 1999.
- [7] M. E. Ropp, M. Begovic, A. Rohatgi, G.A. Kern, R.H. Bonn and S. Gonzalez, "Determining the relative effectiveness of islanding detection methods using phase criteria and nondetection zones," *IEEE Trans. Energy Conversion*, vol. 15, no. 3, pp. 290-296, Sept. 2000.
- [8] A. M. Gole, V. K. Sood and L. Mootosamy, "Validation and analysis of a grid control system using d-q-z transformation for static compensator systems," in *Proc. Canadian Conf. Elect. Comput. Eng.*, Montreal, QC, Canada, Sept. 1989, pp. 745-748.
- [9] *Standard for interconnecting distributed resources with electric power systems*, IEEE Std. 1547-2003, 2003.

Xiaoyu Wang (S'03) received the B.Sc. degree and the M.Sc. degree in electrical engineering from Tsinghua University, Beijing, China, in 2000 and 2003. He is currently pursuing the Ph.D. degree in the Department of Electrical and Computer Engineering at the University of Alberta, Edmonton, AB, Canada. His research interests include distributed generation and power system stability.

Walmir Freitas (M'02) received the Ph.D. degree in electrical engineering from the State University of Campinas, Campinas, Brazil, in 2001. From 2002 to 2003, he was a Post-Doctoral Fellow at the University of Alberta, Edmonton, AB, Canada. Currently, he is an assistant professor at the State University of Campinas. His research interests are distribution systems and distributed generation.

Wilsun Xu (F'05) received the Ph.D. degree from the University of British Columbia, Vancouver, BC, Canada, in 1989. Currently, he is a full professor of electrical engineering at the University of Alberta, Edmonton, AB, Canada, where he has been since 1996. From 1989 to 1996, he was an Electrical Engineer with BC Hydro, BC, Canada. His research interests are power quality and power system stability, and he has recently started to research distributed generation-related subjects.

Venkata Dinavahi (M'00) received the B.Eng. in electrical engineering from Nagpur University, Nagpur, India, in 1993, the M.Tech. degree from the Indian Institute of Technology, Kanpur, India, in 1996, and the Ph.D. degree in electrical and computer engineering from the University of Toronto, Toronto, ON, Canada, in 2000. Presently, he is an associate professor at the University of Alberta, Edmonton, AB, Canada. His research interests include electromagnetic transient analysis, power electronics, real-time simulation and control. Dr. Dinavahi is a Member of CIGRÉ and a Professional Engineer in the Province of Alberta, Canada.