

INFORMATION TO USERS

This manuscript has been reproduced from the microfilm master. UMI films the text directly from the original or copy submitted. Thus, some thesis and dissertation copies are in typewriter face, while others may be from any type of computer printer.

The quality of this reproduction is dependent upon the quality of the copy submitted. Broken or indistinct print, colored or poor quality illustrations and photographs, print bleedthrough, substandard margins, and improper alignment can adversely affect reproduction.

In the unlikely event that the author did not send UMI a complete manuscript and there are missing pages, these will be noted. Also, if unauthorized copyright material had to be removed, a note will indicate the deletion.

Oversize materials (e.g., maps, drawings, charts) are reproduced by sectioning the original, beginning at the upper left-hand corner and continuing from left to right in equal sections with small overlaps.

Photographs included in the original manuscript have been reproduced xerographically in this copy. Higher quality 6" x 9" black and white photographic prints are available for any photographs or illustrations appearing in this copy for an additional charge. Contact UMI directly to order.

Bell & Howell Information and Learning
300 North Zeeb Road, Ann Arbor, MI 48106-1346 USA
800-521-0600

UMI[®]

University of Alberta

**Regulation of Pancreatic Electrolyte Secretion in Cystic Fibrosis: The
Role of Surface Charge and Nitric Oxide.**

by

KAREN THETHI



A thesis submitted to the Faculty of Graduate Studies and Research in partial fulfillment
of the requirements for the degree of Doctor of Philosophy

Department of Physiology

Edmonton, Alberta

Fall, 1999



National Library
of Canada

Acquisitions and
Bibliographic Services

395 Wellington Street
Ottawa ON K1A 0N4
Canada

Bibliothèque nationale
du Canada

Acquisitions et
services bibliographiques

395, rue Wellington
Ottawa ON K1A 0N4
Canada

Your file Votre référence

Our file Notre référence

The author has granted a non-exclusive licence allowing the National Library of Canada to reproduce, loan, distribute or sell copies of this thesis in microform, paper or electronic formats.

The author retains ownership of the copyright in this thesis. Neither the thesis nor substantial extracts from it may be printed or otherwise reproduced without the author's permission.

L'auteur a accordé une licence non exclusive permettant à la Bibliothèque nationale du Canada de reproduire, prêter, distribuer ou vendre des copies de cette thèse sous la forme de microfiche/film, de reproduction sur papier ou sur format électronique.

L'auteur conserve la propriété du droit d'auteur qui protège cette thèse. Ni la thèse ni des extraits substantiels de celle-ci ne doivent être imprimés ou autrement reproduits sans son autorisation.

0-612-46932-8

Canada

University of Alberta

Library Release Form

Name of Author: Karen Thethi
Title of Thesis: Regulation of Pancreatic Electrolyte Secretion in Cystic
Fibrosis: The Role of Surface Charge and Nitric Oxide
Degree: Doctor of Philosophy
Year this Degree Granted: 1999

Permission is hereby granted to the University of Alberta Library to reproduce single copies of this thesis and to lend or sell such copies for private, scholarly, or scientific research purposes only.

The author reserves all other publication and other rights in association with the copyright in the thesis, and except as hereinbefore provided, neither the thesis nor any substantial portion thereof may be printed or otherwise reproduced in any material form whatever without the author's prior written permission.



Karen Thethi
Rowangarth
Mill Lane
Great Ayton
North Yorkshire
TS9 6PX
England

Date: 16th June 99

"While we must all lament the fact that as yet we do not have an effective therapy for cystic fibrosis (CF), there is more reason than ever to believe that an effective treatment will be forth coming. The past ten years have witnessed more interests, more efforts and more discoveries in CF than in all of its previous history combined. In the past fifty years, cystic fibrosis has come from being a rare and minor clinical curiosity to a virtual sub-speciality in clinical medicine and medical research."

Dr. P.M. Quinton, 'Cystic Fibrosis Old Questions: New Answers' The second Joseph Levy memorial lecture, Paris. 1994

University of Alberta

Faculty of Graduate Studies and Research

The undersigned certify that they have read, and recommended to the Faculty of Graduate Studies and Research for acceptance, a thesis entitled **Regulation of Pancreatic Electrolyte Secretion in Cystic Fibrosis: The Role of Surface Charge and Nitric Oxide** submitted by Karen Thethi in partial fulfillment of the requirements for the degree of Doctor of Philosophy.

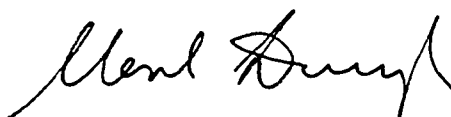

Dr. Marek Duszyk (Supervisor)

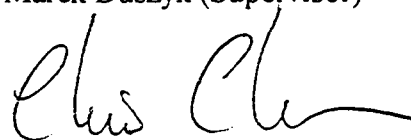

Dr. Chris I. Cheeseman



Dr. S.F. Paul Man



Dr. Malcolm King

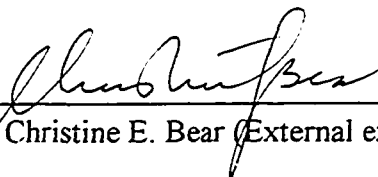

Dr. Christine E. Bear (External examiner)

Date: 9th June '99

Abstract

Defective cAMP-dependent Cl^- secretion in cystic fibrosis (CF) pancreatic duct epithelia leads to the inhibition of bicarbonate secretion into the ductal lumen. Ion channel function is thus fundamental to the pathophysiology of CF and my thesis has addressed two potential mechanisms of ion channel regulation: 1) negative cell surface charge and 2) nitric oxide. The cells used for these studies were pancreas duct epithelial cell lines from control (PANC-1) and CF patients (CFPAC-1).

A colloid titration technique was used to determine the surface charge on the cell membrane. Negative surface charge on CF epithelial cells is significantly reduced in comparison with non-CF cells. This fact may play an important role in the localization of neutrophils to the pancreas duct during inflammation, by enhancing electrostatic adhesive forces between cell surfaces. In addition, ion channel function may be affected by altering the membrane potential, or through direct interactions of surface charges with channel proteins or diffusing ions. Neuraminidase treatment removed approximately the same amount of surface charge in both cell lines, indicating no differences in surface sialylation. Similar results were obtained by direct measurements of the amount of *N*-acetylneuraminic acid released by neuraminidase. In conclusion, decreases in negative surface charge in CF epithelia may amplify the CF defect by increasing neutrophil localization and by inhibiting transepithelial ion movement.

I have characterized the effects of NO on whole-cell current in PANC-1 and CFPAC-1 cells using the perforated whole-cell, patch-clamp technique. The nitric oxide donor *S*-nitrosoglutathione (GSNO) significantly reduced whole-cell current in CFPAC-1 cells but had no effect in PANC-1 cells. This inhibitory effect could be eliminated by

4,4'-diisothiocyanostilbene-2,2'-disulfonic acid (DIDS) or charybdotoxin, suggesting the involvement of DIDS-sensitive Cl^- channels and charybdotoxin-sensitive K^+ channels. This effect was shown to be mediated, at least in part, by cGMP and CFPAC-1 cells were found to be hyper-responsive to GSNO-induced stimulation of soluble guanylate cyclase as compared to PANC-1 cells. Therefore, excessive production of NO, as seen in inflammatory states, may contribute to the CF phenotype by inhibiting transepithelial ion movement and preventing secretion of digestive enzymes produced by the pancreas.

Acknowledgements

There are many people who have helped me both academically and personally throughout my Ph.D. and I find it almost impossible to put into words how much I appreciate what these people have done to help me on my way.

I owe a great debt of gratitude to my supervisor Dr. Marek Duszyk for his never-ending patience, encouragement and understanding over the past four years. Thank you Marek, for all you have taught me and for being an excellent mentor and friend.

Thanks also to Dr. Marek Radomski for his advice in all matters concerning nitric oxide and also to Dr. Anthony K. Ho for help with radioisotope measurements. Jolanta Sawicka, Ewa Parker and Debbie O'Neill must also be given a special acknowledgement. Thank you both for all your help in the laboratory and especially for your encouragement and support as friends.

Special thanks to Drs. Mike and Catherine Wride who took great care of me throughout my time in Edmonton. Without your kindness and sound advice I would never have survived here on my own! I must also express my sincerest appreciation to Bill Keyes, for being a great roommate and best friend. Thanks Bill, for helping me through the emotional "ups and downs" by supporting me through the lows and being there to celebrate the highs with me.

Finally, a most important "overseas" acknowledgement must go to my family: Mum, Dad, Paul and Mark and also Granny and Grandad (who passed away on July 25th, 1998) for always being at the end of the phone line, night and day, cheering me on all the way. Thank you all for being so supportive, I could never have done this without you.

INDEX

CHAPTER I. INTRODUCTION.....	1
A. THE EXOCRINE PANCREAS	2
1. PANCREATITIS.....	5
2. CYSTIC FIBROSIS	6
2.1 <i>Pathophysiology of CF</i>	6
2.2 <i>Therapeutic strategies</i>	16
3. MECHANISMS OF BICARBONATE SECRETION BY PANCREATIC DUCT EPITHELIA.....	21
3.1 <i>Cellular Model for Bicarbonate Secretion in Pancreatic Duct Cells</i>	21
3.2 <i>Secretory Control Mechanisms</i>	25
3.3 <i>Epithelial Sodium channels</i>	26
3.4 <i>Potassium Channels</i>	28
3.5 <i>Chloride Channels</i>	30
B. CELL SURFACE CHARGES AND ION CHANNEL FUNCTION.....	46
1. THE ELECTRICAL DOUBLE LAYER	47
2. SOURCE AND DISTRIBUTION OF CHARGE	52
C. NITRIC OXIDE AND ION CHANNEL FUNCTION.....	56
1. THE NITRIC OXIDE BIOSYNTHETIC PATHWAY	57
2. NITRIC OXIDE AND CYCLIC GMP	60
2.1 <i>Cyclic nucleotide-gated channels</i>	60
2.2 <i>cGMP-dependent protein kinase</i>	61
2.3 <i>Cross-talk pathways</i>	63
3. REDOX MODULATION OF ION CHANNELS	66
CHAPTER II. RATIONALE AND RESEARCH OBJECTIVES.....	71
A. RATIONALE	72
B. OBJECTIVES.....	73
CHAPTER III. EXPERIMENTAL PROCEDURES.....	75
A. TISSUE CULTURE.	76
B. MEASUREMENT OF NEGATIVE SURFACE CHARGE.....	77
1. CELL PREPARATION.	77
2. COLLOID TITRATION.	77
3. DETERMINATION OF SIALIC ACID CONTENT ON THE CELL SURFACE.....	79
3.1 <i>Treatment with Neuraminidase</i>	79
3.2 <i>Quantification of Sialic Acid Removed by Neuraminidase</i>	79
C. PATCH-CLAMP TECHNIQUE.....	80
D. RADIOIMMUNOASSAY FOR CYCLIC-AMP AND CYCLIC-GMP.....	82

E. DETECTION OF SOLUBLE GUANYLATE CYCLASE BY WESTERN BLOT ANALYSIS.....	83
F. MEASUREMENT OF NITRIC OXIDE SYNTHASE ACTIVITY (L-CITRULLINE ASSAY).	84
G. GLUTATHIONE ASSAY.....	85
H. STATISTICAL ANALYSIS.	85
CHAPTER IV. RESULTS	87
A. DECREASED NEGATIVE CHARGE ON THE SURFACE OF CYSTIC FIBROSIS EPITHELIAL CELLS.....	88
1. RECOVERY OF SURFACE CHARGE AFTER TRYPSINIZATION	88
2. THE EFFECT OF CELL GENERATION ON SURFACE CHARGE.....	90
3. DECREASED CELL SURFACE CHARGE IN CYSTIC FIBROSIS EPITHELIA.....	92
B. CHARACTERIZATION OF NITRIC OXIDE ACTION ON ION CHANNELS IN CF PANCREATIC EPITHELIA.....	95
1. THE EFFECT OF NITRIC OXIDE DONORS ON WHOLE-CELL CURRENT IN CF AND NON-CF EPITHELIAL CELLS.....	95
2. INVOLVEMENT OF CONSTITUTIVELY PRODUCED NO IN MODULATING WHOLE-CELL CURRENT IN CF PANCREATIC EPITHELIA.....	98
3. IDENTIFICATION OF CHANNEL TYPES AFFECTED BY NITRIC OXIDE IN CF PANCREATIC EPITHELIAL CELLS.	102
4. A ROLE FOR CALCIUM IN GSNO-INDUCED INHIBITION OF WHOLE-CELL CURRENT	111
5. NITRIC OXIDE INDUCES AN INCREASE IN cGMP IN CFPAC-1 AND PANC-1 CELLS.....	114
6. SOLUBLE GUANYLATE CYCLASE LEVELS IN PANCREATIC DUCT CELLS.....	116
7. NITRIC OXIDE ACTS VIA A cGMP-DEPENDENT PATHWAY.....	118
8. GLUTATHIONE LEVELS IN CF AND NON-CF CELLS.	121
CHAPTER V. DISCUSSION.....	123
A. ALTERED CELL SURFACE CHARGE IN CYSTIC FIBROSIS EPITHELIA.....	124
B. NITRIC OXIDE INHIBITS WHOLE-CELL CURRENT IN CF PANCREATIC EPITHELIAL CELLS.....	130
C. ALTERED REDOX STATUS IN CF PANCREATIC DUCT EPITHELIA: A HYPOTHESIS.	136
D. CONCLUSION AND FUTURE DIRECTIONS.....	140
BIBLIOGRAPHY	143

List of Figures

		Page
Chapter I		
Figure 1	Anatomical basis for fluid secretion in the pancreas duct	4
Figure 2	Pathogenic scheme of disease progression in CF tissues	9
Figure 3	Therapeutic approaches to restoring mutated CFTR	18
Figure 4	Cellular model for bicarbonate secretion in the pancreatic duct	23
Figure 5	Transmembrane topology of CFTR	33
Figure 6	The electric double layer theory	50
Figure 7	Electrostatic forces between two charged surfaces	51
Figure 8	The physiological effects of nitric oxide	59
Figure 9	Physiological biochemistry of NO redox intermediates	68
Chapter IV		
Figure 10	Recovery of negative surface charge after treatment with trypsin	89
Figure 11	The effect of cell generation on negative surface charge	91
Figure 12	The surface charge of PANC-1 and CFPAC-1 cells, with and without neuraminidase treatment	93
Figure 13	Determination of sialic acid content on the cell surface	94
Figure 14	The effect of GSNO on whole-cell current in PANC-1 and CFPAC-1 cells	96
Figure 15	The effect of SNAP on whole-cell current in CFPAC-1 cells	97
Figure 16	Constitutive levels of NO are elevated in CFPAC-1 cells	100
Figure 17	Inhibition of endogenous NOS does not affect basal whole-cell current in CFPAC-1 cells	101

Figure 18	Amiloride does not block the effect of GSNO in CFPAC-1 cells	104
Figure 19	Diltiazem does not block the effect of GSNO in CFPAC-1 cells	106
Figure 20	Charybdotoxin blocks the effect of GSNO in CFPAC-1 cells	108
Figure 21	DIDS decreases the effect of GSNO on whole-cell current in CFPAC-1 cells	110
Figure 22	Depletion of Ca ²⁺ from the cell inhibits the effect of GSNO	113
Figure 23	Intracellular cGMP levels are increased following exposure to GSNO	115
Figure 24	Soluble guanylate cyclase protein expression in pancreatic duct epithelial cells	117
Figure 25	Inhibition of basal whole-cell current in CFPAC-1 cells by 8-Br-cGMP	119
Figure 26	Inhibition of soluble guanylate cyclase eliminates the inhibitory effect of GSNO on whole-cell current in CFPAC-1 cells	120
Figure 27	The effect of GSNO on glutathione levels in CF and non-CF cells	122
Chapter V		
Figure 28	Oxidative stress can deplete free radical scavenging antioxidants and enzymes	137

List of Abbreviations

[Ca] _i	Intracellular calcium
ACh	Acetyl choline
ASL	Airway Surface Liquid
ATP	Adenosine Triphosphate
CACC	Calcium-Activated Chloride Channel
cADPR	Cyclic adenosine diphosphate ribose
cAMP	Cyclic-adenosine monophosphate
CCK	Cholecystokinin
CF	Cystic Fibrosis
CFTR	Cystic Fibrosis Transmembrane Conductance Regulator
cGMP	Cyclic-guanosine monophosphate
CNG	Cyclic nucleotide-gated channels
DIDS	4,4'-diisothiocyanostilbene-2,2'-disulfonic acid
ENaC	Epithelial Sodium Channel
GC-S	Soluble Guanylate Cyclase
GCS	γ-Glutamylcysteine synthetase
GSH	Glutathione (reduced)
GSNO	S-nitrosoglutathione
GSSG	Glutathione (oxidized)
GSTs	Glutathione <i>S</i> -transferases
GTP	Guanosine Triphosphate

K_{ATP}	ATP-dependent Potassium channel
K_{Ca}	Calcium-activate Potassium channel
K_{ir}	Inwardly Rectifying Potassium channel
Na^+/K^+ -ATPase	Na^+ - K^+ Adenosine Triphosphatase
NBF	Nucleotide Binding Fold
NO	Nitric Oxide
NOS	Nitric Oxide Synthase
ORCC	Outwardly Rectifying Chloride Channel
PAP	Pancreatitis-associated Protein
PAPS	Phosphoadenosine phosphosulfate
PDE	Phosphodiesterase
PKA	Protein kinase A
PKC	Protein kinase C
R domain	Regulatory domain
SNAP	S-nitrosopenicillamine
$TNF\alpha$	Tumor Necrosis Factor-Alpha
UTP	Uridine Triphosphate
VIP	Vasoactive Intestinal Peptide

Defined Symbols

(w/v)	weight:volume ratio
g	gravitational acceleration: 9.81 m/s^2
I	Total membrane current
M Ω	unit of resistance: megaohms
M, mM, μ M, fM	unit of concentration: molar, millimolar, micromolar, femtomolar.
mm, nm	unit of length: millimeters, nanometers
ms, s, min	unit of time: milliseconds, seconds, minutes
mV	unit of voltage: millivolts
nA	unit of current: nanoamperes
$^{\circ}$ C	unit of temperature: degrees Celcius
<i>P</i>	statistical significance
pF	unit of capacitance: picofarads
pS	unit of conductance: picosiemens
V	Applied voltage
V_m	Membrane voltage
μ g/ml	concentration: micrograms per milliliter

Chapter I.

Introduction

A. The Exocrine Pancreas

The exocrine pancreas is affected in 85-90 % of cystic fibrosis (CF) patients. The abnormal exocrine secretions, characteristic of CF result in the obstruction of pancreatic ducts, thus leading to poor secretion of digestive enzymes in a bicarbonate-rich fluid into the duodenum (Boat et al., 1989). Fat and protein malabsorption, together with deficiencies of vitamins A, D, E and K are common problems secondary to pancreatic insufficiency (Boat et al., 1989). Current evidence shows that it is the duct epithelial cells, which due to the expression of the mutated CF gene are unable to secrete bicarbonate-rich fluid into the ductal lumen. However, there are still many unanswered questions surrounding the mechanisms that regulate the maintenance of fluid homeostasis in compartments separated by the duct epithelial layer and why, in diseases such as cystic fibrosis, these mechanisms are dysfunctional. My thesis focuses on biophysical mechanisms of epithelial ion channel regulation in the CF pancreatic duct and how channel function can be altered by the cystic fibrosis phenotype.

The constitutive cell types of the pancreas can be divided into two categories: endocrine cells that constitute the islets of Langerhans, and exocrine cells that are involved in enzyme and fluid secretion. An understanding of the three-dimensional organization of the exocrine pancreas provides a basis for understanding the changes that take place during pancreatic disease. The macrolobular structure can be further dissected into microlobular components, each of which are the functional units of the exocrine pancreas. Each microscopic lobule is composed of a ductal branch system, which leads to a spheroidal accumulation of cells known as acinar cells. Acinar cells constitute the majority of the exocrine pancreas and synthesize digestive enzymes, which can be stored

as zymogen granules. Such enzymes include serine proteases, phospholipases and amylase (Rinderknecht, 1993). Duct epithelial cells have been shown to make up only 3-10 % of the exocrine pancreas (Case and Argent, 1993) and although playing a minor role quantitatively, they are essential for the normal function of this organ. It is the duct epithelia, which are the central focus of my thesis.

The pancreatic duct conveys enzymatic secretions produced by acinar cells, from the exocrine pancreas to the duodenum by means of a bicarbonate-rich secretion. The anatomical basis for ductal secretion in the pancreas is shown in figure 1. A dynamic equilibrium is maintained by the buffering capacity of HCO_3^- in the duct. Alkalinization of the acinar lumen allows the solubilization of aggregated digestive enzymes such as trypsin, lipase and amylase, which are packaged as zymogen granules within the acinar cells (Rinderknecht, 1993; Scheele et al., 1996). The release of these exocytotic vesicles from acinar cells leads to loss of membrane surface and apical endocytosis is required for membrane retrieval and recycling. Alkaline duct secretions optimize conditions for this process to occur (Scheele et al., 1996). In conditions such as chronic pancreatitis and cystic fibrosis, acidic ductal accumulations are prevalent. This leads to decreased acinar cell height, due to excessive loss of zymogen granules and the inability to recycle exocytotic membranes. A concomitant increase in acinar lumen diameter is characteristic of these disorders (Scheele et al., 1996). Chronic pancreatitis and cystic fibrosis are two major diseases affecting the exocrine pancreas and the associated pathophysiology that affects Cl^- and HCO_3^- secretion in diseased duct epithelial cells is of central interest to my thesis.

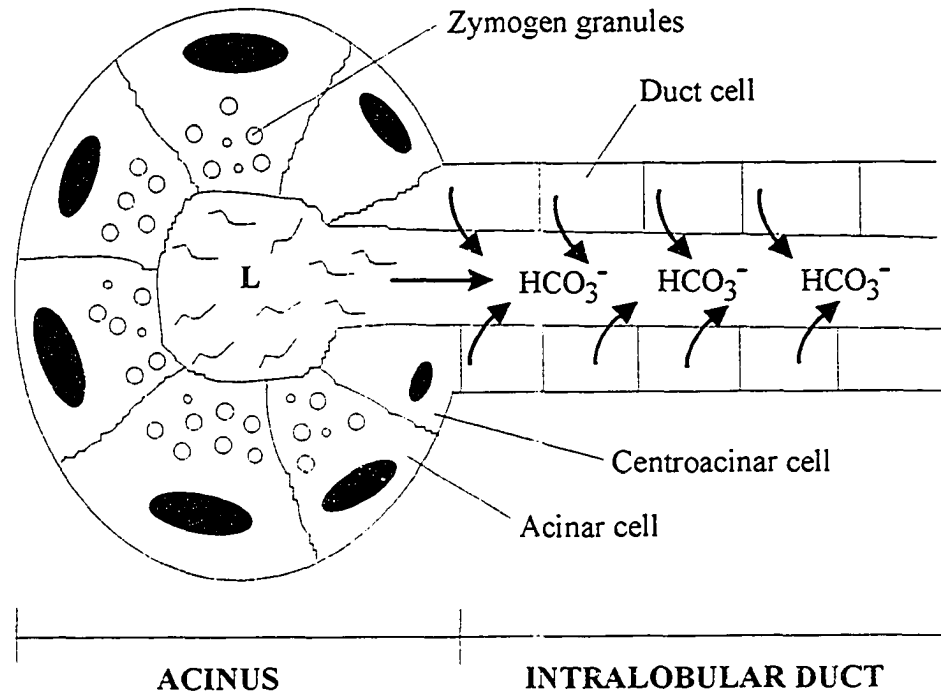

Figure 1. Anatomical basis for fluid secretion in the pancreas duct. Ductal elements include centroacinar cells and duct cells. Contents of zymogen granules are released from acinar cells into the acinar lumen (L) and the HCO_3^- rich fluid, secreted by duct epithelial cells allows transfer of functional digestive enzymes into the intestine.

1. Pancreatitis

Clinical classification of pancreatitis was established in 1963 at the *Symposium of Marseilles* (Sarles, 1965). Pancreatitis presents itself in four categories: (a) acute, (b) relapsing acute, (c) chronic relapsing and (d) chronic (Steer, 1993). In categories a and b, removal of the primary cause or factor may lead to clinical and biological restitution of the gland. In forms c and d residual pancreatic damage persists even if the primary cause or factors are removed. Anatomical or functional derangement of the gland is characteristic of these forms of pancreatitis. Chronic relapsing pancreatitis is defined as chronic pancreatitis with acute exacerbations and the distinction between form c and d are clinical not morphological (Sarles, 1965). Obstruction of the pancreatic drainage system is a common feature of all four of these diseases and while acute pancreatitis is defined as the complete restitution of pancreatic function, chronic illness can result in the incapability of patients to cope socially due to severe and intractable pain (McCloy, 1998). Most severe cases can lead to pancreatic cancer.

The pathways involved in the pathogenesis of this disease are complex. Cystic fibrosis is a major cause of pancreatitis in infants and will be described in the next section. Recent studies have described oxidant stress as a triggering factor of pancreatitis and this is of particular interest to my thesis for reasons, which will become clear in later in this chapter. High serum triglyceride levels can lead to pancreatic injury through their breakdown in the pancreas microcirculation (Dodge, 1998). The resulting release of free fatty acids, combined with an insufficiency of antioxidant defence mechanisms in pancreatic cells, may initiate lipid peroxidation (McCloy, 1998). This is a chain reaction and can cause the disintegration of cell membranes (Halliwell and Gutteridge, 1989). Cell

debris and zymogen granules then precipitate in the duct lumen and result in duct obstruction. Neutrophils, recruited by an inflammatory response associated with pancreatitis, are a primary source of reactive oxygen species, thus amplifying the damaging effect (Al-Mufti et al., 1998). Oxidant stress in the pancreas has been shown to result from the metabolism of xenobiotics and this is a problematic cause of chronic pancreatitis by depleting glutathione levels (McCloy, 1998).

Hereditary forms of pancreatitis have long since been recognized to be caused by inappropriate activation of pancreatic proenzymes. The premature activation of enzymes such as trypsin has been shown to be linked with autodigestion of the pancreas (Dodge, 1998). Several studies have mapped genes involved in hereditary forms of pancreatitis to regions on chromosome 7. This is of particular interest since the gene encoding the cystic fibrosis transmembrane conductance regulator (CFTR) is also found in this region (Le et al., 1996).

2. Cystic Fibrosis

2.1 Pathophysiology of CF

“Mucoviscidosis” was a term proposed in the late 1930’s to denote the plugging of organ passages throughout the body with viscid mucus. Dorothy Andersen was first to apply the term “cystic fibrosis” in 1938 on account of the state of the exocrine pancreas upon postmortem examination (Andersen, 1938). The characteristic cyst formation in acinar tissue and the fibrotic appearance of ductal cells is now recognized as a hallmark of the disease. The earliest recognition of characteristic CF symptoms dates back to the Middle Ages. Medieval folklore of Eastern European countries predicted death for a child that tasted ‘salty’ when kissed and these children were thought to be bewitched (Quinton,

1999). It wasn't until the early 1950's, that the salt concentration in sweat from CF patients could be quantified and was found to be greatly elevated (di Sant'Agnesse et al., 1953). High sweat NaCl concentration is now known to be pathognomonic of CF and its measurement is essential for diagnosis. This observation led to the discovery of the chloride secretory abnormality affecting multiple secreting epithelial tissues by Paul Quinton in 1983 (Quinton, 1983). Chloride channels on the apical surface of secreting epithelia were found to be unresponsive to regulatory pathways involving cAMP. The etiology of CF is very complex, but it is primarily a disease of electrolyte transport, and is characterized by defective epithelial fluid secretion in various tissues, mainly the pancreas, sweat ducts, airways and intestine. The inhibition of Cl⁻ and bicarbonate secretion through CFTR was shown to result in secretion of mucus with reduced water content and altered rheological properties (Trout et al., 1998). This phenomenon underlies many of the manifestations of cystic fibrosis pathophysiology.

CFTR

CF is an inherited autosomal recessive disease and is most common in Caucasian populations with a carrier frequency of around 5 % and a disease incidence of between 1:2000 and 1:3000 live births (Boat et al., 1989). In 1989, the gene that is defective in CF was cloned (Rommens et al., 1989) and the product was named the cystic fibrosis transmembrane conductance regulator (CFTR). The gene is located on the long arm of chromosome 7 and the transcribed region encodes 6.5 kb of mRNA. The resulting protein is a 1,480 amino acid sequence and on the basis of hydropathy plots, the molecule is comprised of a repeating 6 transmembrane domain sequence, the properties of which will be described in section 3.5.

Over 800 different mutations of CFTR have been described all of which cause CF to varying degrees of severity (<http://www.genet.sickkids.on.ca/cftr/>). The most common and most lethal mutation of the gene is a deletion of a phenylalanine residue at position 508 in the amino acid sequence ($\Delta F508$) and occurs in 69 % of Canadian and American CF chromosomes (Durie, 1997). This deletion causes CFTR to be retained in the endoplasmic reticulum, resulting in a lack of cAMP-dependent Cl^- conductance at the apical surface of affected epithelial cells. However, the Cl^- channel function remains intact and unaffected by the $\Delta F508$ mutation (Pasyk and Foskett, 1995). At this point it is necessary to describe the pathogenesis of CF in different tissue types, in order to gain an understanding of how the dysfunctional Cl^- secretory processes can induce such a complex pathological state. Figure 2 describes the pathogenic cascade that is initiated by mutation of the CFTR gene.

The Lung

Airway obstruction and chronic bacterial lung infections are the most life-threatening characteristics of CF (Boat et al., 1989). Mucus secretions associated with lung infection, mostly by *Pseudomonas aeruginosa*, are thick and viscid and the rheology is altered mainly by the presence of cellular and bacterial debris, especially DNA (King et al., 1997). The film of liquid that covers the epithelial lining of the airways is comprised of two distinct layers: a mucous gel lies on the upper surface, above the tips of the cilia and is the first line of defense against foreign particles and bacteria. The periciliary layer, or sol, is a watery layer that bathes the cilia and the separation of the two layers is maintained through cross-linking of mucins (Widdicombe, 1997). Mucociliary clearance is optimal when cilia tips are in contact with the underside of the gel layer. As the cilia

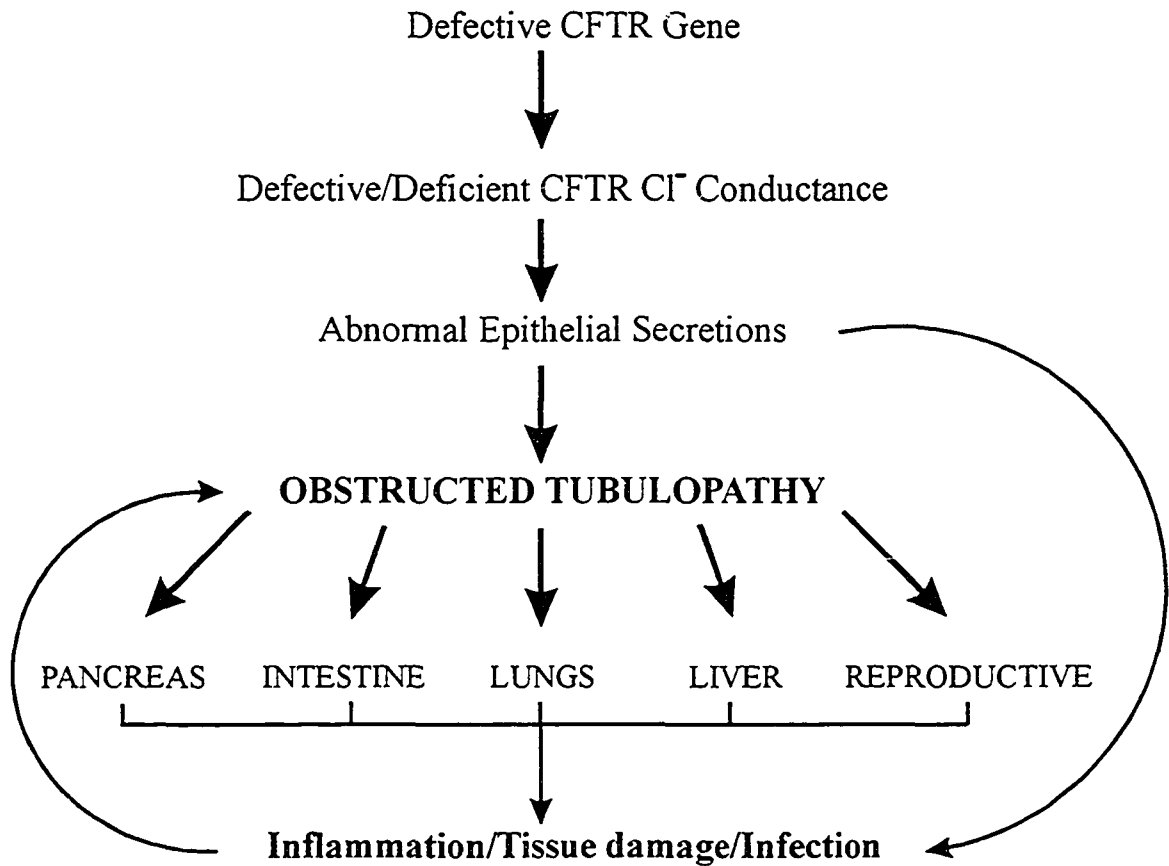

Figure 2. Pathogenic scheme of disease progression in CF tissues.

are allowed to beat in the sol layer, the mucous layer is driven up the airways where it can be expectorated or swallowed. The sol is maintained at a constant depth, usually the same as that of the cilia length, whereas the depth of the mucous gel varies, becoming much deeper in conditions such as bronchitis, asthma and CF (Widdicombe and Widdicombe, 1995; Wu et al., 1998).

There are several roles for CFTR in maintaining airway surface liquid (ASL) homeostasis. Firstly, altered glycosylation of tracheobronchial mucins from CF patients

has been reported, predominantly decreased sialylation and fucosylation and excessive sulfation (Dosanjh et al., 1994a; Scanlin et al., 1985; Zhang et al., 1995). This disrupts rheological properties and efficient mucociliary clearance, although it is not clear how defective CFTR is involved in this. Secondly, a role for CFTR as a cellular receptor for binding, endocytosing and clearing *P. aeruginosa* has recently been described. Pier, et al. (Pier et al., 1997) demonstrated that the first extracellular domain of CFTR specifically bound to *P. aeruginosa* cells and that murine lung epithelia expressing wild-type CFTR were capable of ingesting 30-100 times as many bacterial cells as those expressing the $\Delta F508$ mutated CFTR protein.

The third and most prominent role for CFTR is displayed by altered salt secretion caused by mutated CFTR, which leads to altered fluid secretion. In the lung, CFTR is predominantly localized to the apical surface of submucosal serous epithelial cells (Engelhardt et al., 1992). These cells are responsible for maintaining the fluid component of airway gland secretions and flush out mucins secreted by mucous cells in the submucosal gland (Finkbeiner et al., 1994). In CF lung epithelia, dysfunctional CFTR results in decreased cAMP-dependent Cl^- secretion and in addition, an increased rate of sodium absorption through amiloride-sensitive sodium channels results in a concomitant reduction in fluid secretion (Jiang et al., 1997; Chinet et al., 1994). The resulting change in mucus viscosity contributes to the accumulation of airway mucus which is characteristic of the disease. However, there are contrasting views on the exact mechanism by which altered salt transport in CF can permit such severe microbial infection. The composition and volume of airway surface liquid are crucial in resolving the mechanism of airway defense and how this is impaired in CF. Two different views

have recently been presented on this matter. One report has proposed that it is the volume of the periciliary sol liquid, which in CF is decreased due to either hyperabsorption or defective secretion of fluid (Matsui et al., 1998a). This decrease in sol depth disables the efficiency of cilia movement and reduces mucociliary clearance, thus, becoming favorable for microbial growth (Matsui et al., 1998b; Matsui et al., 1998a). The contrasting opinion from a second group of investigators looks at the inherent defense mechanisms in the mucous layer (Smith et al., 1996). Defensins are small cationic peptides, produced by human epithelial cells and neutrophils, with broad-spectrum antimicrobial activity and their ability to kill bacteria is salt sensitive (McCray and Bentley, 1997). Reports of elevated salt concentration in surface liquid in CF (Joris et al., 1993) led this group to investigate the bactericidal activity of defensins present in the airway surface liquid and these studies suggested that they are dysfunctional due to increased salt concentrations in CF patients (Smith et al., 1996). Recent evidence using human bronchial xenografts demonstrates that the volume of airway surface liquid in CF patients is decreased, consistent with findings from the first group. However, a small but significant elevation in surface liquid Cl^- concentration was found to be apparent in CF tissue as compared to non-CF xenografts, consistent with the observations concerning defensin function (Zhang and Engelhardt, 1999). The authors conclude that such a small elevation in ASL salt concentration would not be sufficient to inhibit defensin function, adding to the conundrum of abnormal ion and fluid movement across the airway epithelium. The xenograft model also showed that Na and Cl are hyperabsorbed by CF bronchial epithelia in an equimolar ratio, suggesting that increased Cl at the apical surface is not the result of decreased apical Cl permeability (Zhang and Engelhardt,

1999). There are still many questions surrounding these postulates and I refer the reader to a recent review on CFTR-related changes to the airway surface microenvironment, for a more in-depth account of CF lung pathophysiology (Pilewski and Frizzell, 1999).

The Sweat Gland

In the sweat gland, the secretory coil consists of two morphologically distinct regions. The secretory epithelia are located at the end of an unbranched tubule while, towards the distal end a double layer of reabsorptive epithelial cells form a continuous fluid barrier along the lumen of the duct. Three different types of epithelial cells are present in the sweat gland: myoepithelial cells (involved in contractile responses of the gland), β -adrenergic-insensitive cells (β -I; involved in secreting macromolecules) and β -adrenergic-sensitive cells (β -S; involved in fluid secretion). The physiology of these cells and functional abnormalities in CF have been described extensively elsewhere (Quinton and Reddy, 1993). Although the defective exocrine function of the secretory coil had clearly been established (Sato and Sato, 1984), it wasn't until recently that the specific cell type affected by CF in the sweat gland was identified. The application of forskolin (an activator of adenylate cyclase) to β -S cells from non-CF patients, caused an activation of CFTR Cl^- conductance. In contrast, β -S cells from CF patients showed no electrical response to β -adrenergic stimulation (Reddy and Quinton, 1997). Thus a lack of cAMP-dependent Cl^- secretion in these cells results in a reduction of fluid secretion into the duct lumen. It is fortunate that the CF sweat gland is still responsive to cholinergic stimulation. This allows relatively normal secretion of sweat into the duct lumen and it is thought that Ca^{2+} -activated K^+ channels in the basolateral membrane and Ca^{2+} -activated Cl^- channels in the apical membrane are involved in this response (Reddy and Quinton,

1997). However, because of dysfunctional CFTR in the apical membrane of reabsorptive cells, Cl⁻ reabsorption is impeded and thus, sweat is secreted onto the skin surface with a salt concentration two to five times higher than normal (Quinton, 1994).

The Intestine

As in the lung, intestinal epithelia exhibit a defect in cAMP-mediated Cl⁻ secretion (Taylor et al., 1988; Grubb, 1997). Disease incidence of CF in Caucasian populations is between 1:2000 and 1:3000 live births (Boat et al., 1989) and such a high frequency cannot be explained by random mutation. Experiments using CF mice have suggested that there is a survival advantage for CF heterozygotes. These mice express around 50 % of the normal amount of wild-type CFTR Cl⁻ channel in the intestinal epithelium, thus allowing only 50 % of the normal fluid secretion levels (Gabriel et al., 1994). Protection in infancy may occur against the effects of cholera toxin, by resistance to cAMP-dependent toxigenic diarrhea. This infection has previously been associated with high infant mortality (Durie, 1997).

The lack of Cl⁻ at the apical surface of the intestinal lumen leads to enhanced Na⁺ reabsorption to maintain electroneutrality. Enhanced sodium-coupled glucose uptake in the small intestine also contributes to the luminal dehydration characteristic of CF (Frase et al., 1985; Beesley et al., 1996). Beesley and Hardcastle have suggested that active glucose uptake is enhanced by cellular mishandling of K⁺ ions. Intracellular K⁺ may be capable of displacing Na⁺ ions from the Na⁺/glucose cotransporter on the inside of the cell membrane. This would then release the glucose and promote further transport by allowing the carrier to return to a conformation suitable for membrane recycling (Beesley et al., 1997). This suggestion is validated by a report showing fact that cystic fibrosis

enterocytes have higher intracellular K^+ concentrations than non-CF cells (O'Loughlin et al., 1996).

The Pancreas

It is the CF pancreas that is of central interest to my thesis and how the CF phenotype alters ion channel regulatory mechanisms in duct epithelial cells. Dysfunctional CFTR Cl^- secretion leads to blockage of the ductal system and eventual fibrosis of the whole gland. Around 85 % of CF patients are pancreatic insufficient, i.e. the blockage of the pancreas duct leads to a decrease in digestive enzymes in the duodenum (Durie, 1997). CF patients with pancreatic insufficiency require enzyme supplements with meals and this severe pancreatic disease is often associated with the $\Delta F508$ mutation (described below) (Gray et al., 1995). The cellular mechanism by which CFTR influences pancreatic HCO_3^- secretion will be described in section 3.

Chronic pancreatitis, as mentioned previously, has been connected with the CF phenotype (Durie, 1997). Recent investigations have linked mutations in the CF gene with this pancreatic disorder (Sharer et al., 1998). Cystic fibrosis is by far the most common cause of pancreatitis in infants and among the most characteristic observations in surgically removed tissue and postmortem samples were inflammatory cell infiltration and focal dilation of acinar lumina and ductules (Stein et al., 1963; Oppenheimer and Esterly, 1975). Acinar cells were seen to be greatly atrophic and with very few zymogen granules in these studies. Histological differences between a severe CF pancreas and those of end-stage chronic pancreatitis are indistinguishable (Dodge, 1998).

It has recently come to the attention of several groups that certain genetic factors other than mutated CFTR may leave some CF sufferers predisposed to a more severe CF

phenotype in the pancreas. When submitted to sustained physiological stresses, known to induce pancreatitis, the pancreas produces proteins to counteract the event. The pancreatitis-associated protein (PAP) family comprises three genes found in man and their expression is upregulated in the acute-phase response to pancreatic stress and can be used as a marker of chronic pancreatitis. A recent report has proposed PAP to be an accurate marker for CF screening in neonates (Sarles et al., 1999). PAP-1 protein has been shown to aggregate bacteria in suspension and recent observations have implicated PAP-1 in the progressive establishment of intestinal flora. Furthermore, PAP-1 has been shown to increase the resistance of cells to oxidative stress, a significant factor in the response to chronic pancreatitis (Dagorn, 1997).

Reg protein is involved in the regeneration of pancreatic beta cells and is present in the pancreatic juice of patients suffering from chronic pancreatitis. The solubility of this protein is significantly affected by concentration at neutral pH and therefore is susceptible to precipitation in the duct lumen of CF patients (Forstner et al., 1989). Damage to pancreatic tissue in CF is amplified by an infiltration of neutrophils and phagocytes (Dodge, 1998) and release of cytokines and reactive oxygen species from these cells can be deleterious to pancreatic tissue and other organs affected by CF (Konstan and Berger, 1997). Tumor necrosis factor- α (TNF- α) is a pro-inflammatory cytokine that is capable of inducing oxidative stress in the pancreas (Al-Mufti et al., 1998). Two different alleles are apparent in the promoter site of the TNF- α gene; TNF1 and TNF2. The latter has been associated with higher constitutive and inducible levels of TNF- α transcription. This naturally occurring variant has recently been shown to be a determinant in the disease severity of CF (Hull and Thomson, 1998). In the same study,

glutathione S-transferase (GSTM1), which detoxifies potent oxidative molecules by catalyzing the formation of conjugates with glutathione, was proposed as another genetic factor influencing CF disease severity. A null allele of GSTM1 does not produce protein, thus depleting the tissue antioxidant status and rendering the tissue susceptible to oxidative stress (Groppi et al., 1991). Although little data is available on the involvement of these genes in CF, this area of investigation into the CF phenotype is becoming more interesting and important in the development of a cure for CF.

2.2 Therapeutic strategies

The strategic use and development of antibiotic therapies to treat lung infection has increased the survival probability of CF patients greatly over recent years (Frederiksen et al., 1996). However, repeated and prolonged treatments with antibiotics result in the emergence of resistant bacterial strains (Lang et al., 1995). New treatments under consideration to avoid this problem include new anti-inflammatory agents and alternative antibiotic treatment strategies. Correcting the source of the disease would abort the pathogenic cascade (figure 2) and avoid any other therapeutic complications. New CF therapies are focused on the development of agents that would correct the CFTR defect. Here, I will give a brief review of therapeutic strategies that may led the way to a cure for CF, by correcting the functional defect in CFTR. Figure 3 outlines the three main areas of investigation into restoring functional Cl⁻ conductance at the apical membrane of affected epithelial cells.

Gene and Protein-Replacement Therapy

In theory, transfer of normal CFTR cDNA into affected cells, should enable the cell to produce sufficient quantities of normal CFTR and correct the ion transport defects. In practice however, there are still several questions, which challenge the effectiveness of this approach (Stern and Alton, 1998; Jaffe et al., 1999). The diseased lung is the principal site of morbidity and mortality therefore the airway epithelia are prime targets for gene therapy (Boucher R.C., 1999). However, airway epithelia are a heterogeneous cell population and the submucosal glands are the prime sources of CFTR. The targeting of specific cell types in the airways presents an initial obstacle. Finding a suitable vector for delivery of CFTR cDNA has invited much discussion. Viral vectors have long since been used *in vitro* and are known for their efficiency and simple manipulation. However, the use of viral vectors in CF patients poses certain safety issues, the induction of a host inflammatory response, being most problematic (Smith, 1995). The use of synthetic delivery vectors now seems to be a useful alternative. Cationic liposomes consist of a cationic lipid component and a fusogenic component. DNA complexed with the liposome through electrostatic interactions has been administered in trials with transgenic mice and CF humans. For a detailed review on the use of lipofection see (Schreier and Sawyer, 1996). An alternative to transfecting the cDNA into epithelial cells is to insert a functional protein. Protein replacement therapy has been attempted using influenza hemagglutinin (HA) to mediate the delivery of CFTR-containing liposomes to the cell surface (Scheule et al., 1995). Due to the rate of cellular turnover of the CFTR protein and the inefficiency of protein delivery, this therapy would need to be frequently administered (Smith, 1995; Graham, 1993). More recent attempts successfully transferred

purified CFTR protein via phospholipid liposomes into the membrane of nasal epithelial cells in CFTR knockout mice (Ramjeesingh et al., 1998). The effectiveness of this procedure appeared to be limited by the inefficient incorporation of CFTR into the apical epithelial cell membrane.

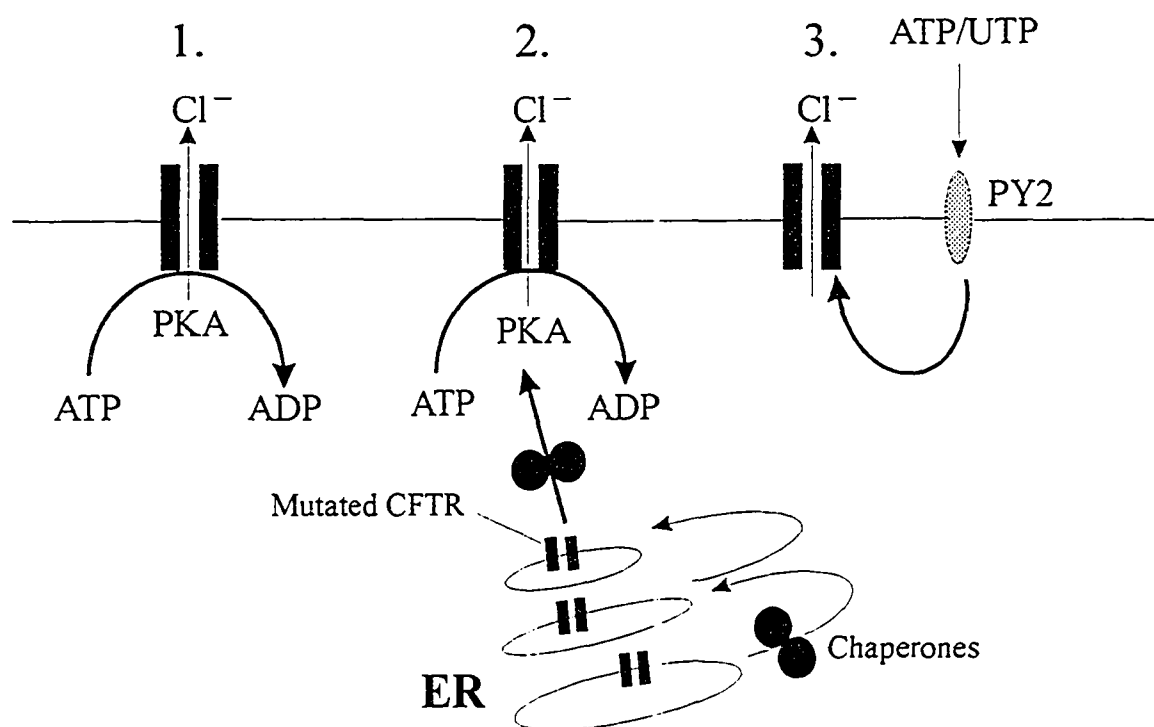

Figure 3. Three different approaches are currently considered for restoring defective Cl⁻ secretion in CF epithelia. 1. Functional CFTR delivery. Insertion of a functional CFTR gene or protein into affected cells, enables the expression of wild-type CFTR at the apical membrane surface. 2. Restoration of mutated CFTR, making the most of a bad gene with chemical or molecular chaperones (ER = endoplasmic reticulum) 3. Activation of alternative Cl⁻ channels.

Protein Repair Therapy

As mentioned previously, there are over 800 mutations of CFTR. Treatments that target CFTR mutants by functional activation or correcting other defects are extremely appealing, as these proteins can then be processed and function correctly in the appropriate cell type affected. Mutations are grouped according to a physiological perspective and five major mutation categories have been identified, based on the primary mechanism responsible for reduced CFTR at the apical surface (Pilewski and Frizzell, 1999; Zeitlin, 1999). Class 1 is a result of frameshift or stop codon mutations where no protein is produced. Class 2 mutations are subject to improper biosynthetic handling and fail to mature past the endoplasmic reticulum, although Cl⁻ channel function is retained. $\Delta F508$ is typical of this class (Pasyk and Foskett, 1995). Class 3 and 4 mutants have abnormalities within the Cl⁻ channel itself. Channels are either insensitive to activation or display altered Cl⁻ conductance. Thus for allele specific treatment the phenotype of the mutation has to be considered to make the best of a bad gene. Pharmacological therapies used to restore mutated CFTR have recently been reviewed with respect to the spectrum of defects in the CFTR protein (Zeitlin, 1999).

Recently, attempts to restore cellular processing of class 2 mutants, such as $\Delta F508$, have led to the application of N-acetyl-L-cysteine and butyrate, which are capable of improving the folding of mutant proteins and inducing a measurable increase in apical Cl⁻ conductance (Brown et al., 1997; Rubenstein et al., 1997). However, the mechanisms by which these compounds elicit their effects are not fully understood. The realization that $\Delta F508$ is a temperature-sensitive mutation, led to the use of low-molecular weight compounds capable of stabilizing proteins against thermal degradation. Such compounds

include DMSO, glycerol and deuterated water (D₂O) and are now collectively labeled as 'chemical chaperones' (Bebök et al., 1998; Sato et al., 1996; Brown et al., 1997). The application of such compounds enables partial correction of the processing defect of Δ F508 CFTR protein and cAMP-dependent Cl⁻ transport is restored at the apical surface of the cell (Brown et al., 1997).

Molecular chaperones, calnexin and heat shock protein 70 (Hsp70), are thought to bind early in the folding process to extend conformations of polypeptide chains. However, in contrast to the wild type CFTR, mutant Δ F508 CFTR is unable to dissociate from these chaperone molecules and thus is unable to exit from the endoplasmic reticulum (Jiang et al., 1998). Therapeutic intervention using compounds that interfere with the normal functioning of these chaperones may provide a way of correcting the Δ F508 processing defect. Deoxyspergualin (DSG) has been shown to increase cAMP-dependent Cl⁻ conductance at the surface of cells expressing the Δ F508 mutation (Jiang et al., 1998). DSG mediates its effects, at least in part, by its ability to interact with Hsp70. The constitutively expressed Hsp70 isoform, heat shock cognate 70 (Hsc70), has been shown to interact with the immature wild type and Δ F508 CFTR and promotes efficient folding of the protein (Strickland et al., 1997).

Activation of Alternative Chloride Channels

Although cAMP-dependent activation of Cl⁻ conductance is dysfunctional in CF epithelia, Cl⁻ channels, which are regulated by different mechanisms are present in affected epithelia. Of these channel types, the Ca²⁺-activated Cl⁻ channels and the outwardly rectifying Cl⁻ channel (ORCC) have been utilized as therapeutic targets in airway epithelia to increase anion secretion. Extracellular ATP and UTP have been

shown to activate Cl^- secretion in CF airway epithelia and are now known to provide an alternative pathway to circumvent dysfunctional CFTR (Knowles et al., 1991). ATP stimulates Cl^- secretion through $\text{P}_{2\text{U}}$, or $\text{P}_{2\text{Y}2}$ purinergic receptors at the apical surface, via pathways that are both dependent and independent on intracellular Ca^{2+} (Hwang et al., 1996). ATP was suggested to stimulate $\text{P}_{2\text{U}}$ receptors, which in turn act to transduce the release of intracellular Ca^{2+} , thus activating Ca^{2+} -dependent Cl^- channels. In addition, direct receptor interaction with ORCC domains may also led to activation of Cl^- secretion at the apical membrane. A concurrent increase in basolateral K^+ conductance in response to purinergic induced increases in $[\text{Ca}^{2+}]_i$ has been shown to increase the driving force for Cl^- to exit across the apical membrane of epithelial cells (Inoue et al., 1997; Clarke et al., 1997). This mechanism will be described in detail in section 3.

The rate of sodium absorption through amiloride-sensitive channels in CF epithelia is increased and constitutes a major characteristic in CF fluid reabsorption (Chinet et al., 1994). The use of amiloride and its derivative, benzamil are currently used as therapeutic drugs in an attempt to restore normal hydration of airway surface liquid in CF patients (Blank et al., 1995). Thus, the combination of applying nucleotides to stimulate Cl^- secretion and amiloride to inhibit Na^+ reabsorption is currently an attractive method of improving mucous rheology in CF.

3. Mechanisms of Bicarbonate Secretion by Pancreatic Duct Epithelia

3.1 Cellular Model for Bicarbonate Secretion in Pancreatic Duct Cells

The coordinated regulation of NaCl secretion, in conjunction with the $\text{Cl}^-/\text{HCO}_3^-$ exchanger governs the extrusion of HCO_3^- in to the duct lumen. A cellular model of ion

channels and transporter elements, which constitute $\text{NaCl}/\text{HCO}_3^-$ secretory pathways in pancreatic duct epithelia, has been established using electrophysiological and spectrofluorometric techniques (Greger, 1996a) in conjunction with mathematical modeling, based on measurement of the electrochemical gradients for transported ions across the apical and basolateral membranes (Sohma et al., 1996). Figure 4 describes the basic cellular model of HCO_3^- secretion in pancreatic duct epithelia and the membrane localization of ion channels and transporters.

The current model of bicarbonate secretion in the pancreatic duct suggests that bicarbonate be generated inside the epithelial cells by releasing H^+ and HCO_3^- ions as a result of carbonic anhydrase catalyzing the hydrolysis of CO_2 (Gray et al., 1995). A recent report has proposed the presence of a $\text{Na}^+-\text{HCO}_3^-$ cotransporter (NBC) in the basolateral membrane of cultured human pancreatic duct cells, and that the uptake of HCO_3^- into the cell is dependent on cAMP-stimulated Cl^- secretion through CFTR (Shumaker et al., 1999). This observation has not yet been incorporated into the currently accepted cellular model shown in figure 4. Protons are removed by means of the basolateral Na^+/H^+ exchanger and also by the H^+ -ATPase pump. Bicarbonate accumulates inside the cell and exits via the $\text{Cl}^-/\text{HCO}_3^-$ exchanger at the apical membrane. This part of the process is dependent on the Cl^- concentration in the lumen in order to allow anion exchange to occur, and thus apical Cl^- channels become rate-limiting factors (Cheung et al., 1998). As depicted in figure 4, the Na^+/K^+ -ATPase and $\text{Na}^+\text{K}^+2\text{Cl}^-$ cotransporter provide the driving force for anion secretion. As the Na^+/K^+ -ATPase in the

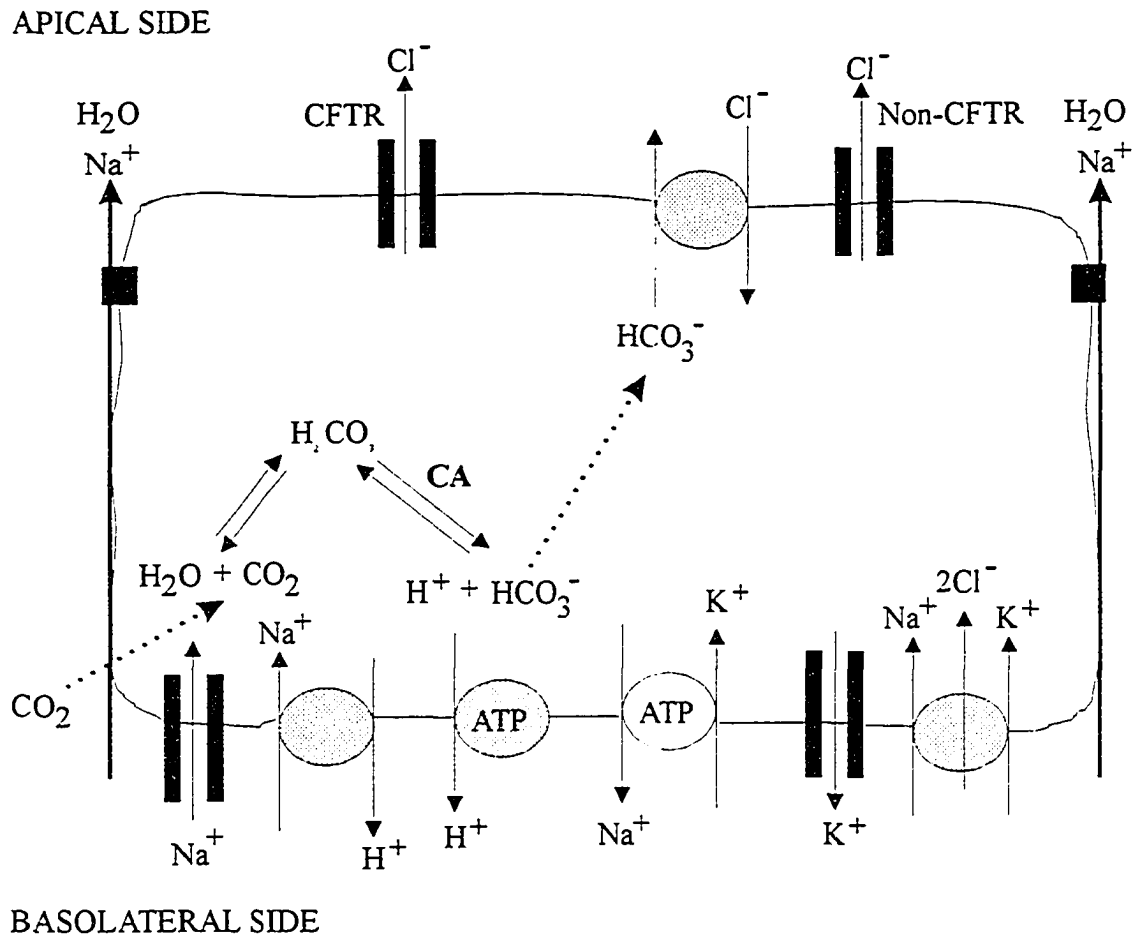

Figure 4. Cellular model for bicarbonate secretion. CA = carbonic anhydrase. Na^+ and H_2O move by following the electrochemical gradient through the paracellular pathway. The potential created across the basolateral membrane drives the secretion of Cl^- and HCO_3^- at the apical membrane.

basolateral membrane extrudes Na^+ from the cell against its electrochemical gradient, it can be recycled back into the cell by the $\text{Na}^+\text{K}^+\text{2Cl}^-$ transporter, thus providing the energy to drive Cl^- and K^+ into the cell against their electrochemical gradient (Frizzell et al., 1979). This electroneutral transport across the basolateral membrane allows Cl^- to exceed its equilibrium potential within the cell and so is secreted via Cl^- channels in the apical membrane. Basolateral K^+ channels are also rate-limiting in the secretion of Cl^- and HCO_3^- as they maintain electroneutrality at the basolateral membrane and a route for recycling K^+ ions. As Cl^- and HCO_3^- moves into the lumen across the apical membrane, Na^+ is drawn through a paracellular pathway and water follows osmotically. The net result is the secretion of a fluid rich in NaHCO_3 and some Cl^- (Martin and Shuttleworth, 1996). Bicarbonate concentrations in the duct lumen vary between 70-140 mM, according to species and are about 5-6 times greater than that in plasma (Sohma et al., 1996). This species-dependent variation in bicarbonate concentration between species must be considered when comparing secretory stimulation responses (Case and Argent, 1993).

Pancreatic duct cells can be stimulated to secrete bicarbonate-rich fluid by two main mechanisms: 1) hyperpolarization of the cell and 2) stimulation of apical Cl^- channels. Hyperpolarization occurs through the opening of K^+ channels in the basolateral membrane of the cell. This induces a net decrease in intracellular K^+ and so the $\text{Na}^+\text{K}^+\text{2Cl}^-$ cotransporter is activated or upregulated, bringing Cl^- into the cell. The increase in Cl^- concentration above the electrochemical equilibrium causes increased Cl^- secretion. Consequently, solute-water coupling through osmotic gradients allows fluid to be secreted onto the apical surface of the monolayer and Cl^- is recycled in exchange for

HCO_3^- . Direct stimulation of apical Cl^- channels allows Cl^- to move out of the cell, down its electrochemical gradient. These two mechanisms appear to work in conjunction, to maintain epithelial secretion in pancreatic duct epithelia (Case and Argent, 1993).

3.2 Secretory Control Mechanisms

The presence of acid chyme in the duodenum following a meal is the dominant method of up-regulating pancreatic bicarbonate secretion. The three major stimuli involved in this response are secretin, cholecystokinin (CCK) and vagal nerve stimulation and the role played by each of these stimuli has been reviewed in detail (Case and Argent, 1993). Secretin, CCK and vagal nerve stimulation through neurotransmitters such as vasoactive intestinal peptide (VIP) and acetylcholine (ACh), all act by increasing calcium or cAMP concentrations in pancreatic duct epithelial cells (Case and Argent, 1993; Martin and Shuttleworth, 1996; Ashton et al., 1993). The stimulation of cAMP production by secretin and VIP results in the activation of apical Cl^- channels, notably of CFTR (Martin and Shuttleworth, 1996). This leads to an increase in Cl^- in the ductal lumen and so according to the secretory model presented above, increases the cycling rate of the $\text{Cl}^-/\text{HCO}_3^-$ exchanger. It is interesting to note that in some intrinsic neurons VIP is colocalized with Ca^{2+} -mobilizing agents such as neuropeptide Y (NPY). The synergistic action of Ca^{2+} and cAMP maintains HCO_3^- secretion by the stimulation of basolateral Ca^{2+} -activated K^+ channels and also apical Cl^- channels and similar synergistic effects are seen with other cAMP and Ca^{2+} agonists such as secretin and ACh, respectively (Gray et al., 1995). It is the mechanisms of regulating HCO_3^- secretion by ion channel function in cystic fibrosis duct epithelia, which is of central interest to my thesis. An understanding

of the ion channels present in epithelial cells and their individual characteristics is necessary to discuss further, the mechanisms regulating epithelial secretion.

3.3 Epithelial Sodium channels

The epithelial sodium channel (ENaC) is present in the membrane of epithelial cells from many tissue types. It is mostly associated with absorptive processes involved in regulating extracellular fluid volume and is distinguished from voltage-gated Na^+ channels by its sensitivity to micromolar concentrations of amiloride and the fact that it is only slightly voltage sensitive (Canessa et al., 1994). Pancreatic duct epithelia are primarily secretory cells and according to the model proposed by Sohma et al. sodium channels are present in the basolateral membrane (Sohma et al., 1996). The identity of this Na^+ conductance has not been elucidated. Primarily absorptive tissues such as airway epithelia display ENaC, which is involved in fluid reabsorption, at the apical side of the cell (Barbry and Hofman, 1997). The physiological importance of ENaC, if present in pancreatic duct epithelia may be similar to that in airway epithelia, being involved in fluid reabsorption. It has recently been suggested that ENaC can regulate intracellular volume as well as extracellular volume. A recent report has demonstrated that intracellular pH can regulate ENaC by a voltage-independent mechanism. Alkalinization increases, whereas acidification inhibits channel activity (Chalfant et al., 1999).

ENaC has been characterized in the lung, distal colon and kidney collecting tubules and ducts (Barbry and Hofman, 1997). Single channel conductance of ENaC expressed in oocytes is around 7 pS and the ability for amiloride to block channel activity is a hallmark of this channel type (Canessa et al., 1994; Voilley et al., 1997). Its physiological significance can be seen when mutations are present in diseases such as Liddle syndrome

(type 1 pseudohypoaldosteronism). Here, hypertension is the result of a mutation at the carboxy end of the α and β subunits causing constitutive activation of ENaC (Barbry and Hofman, 1997). Furthermore, mutations that inactivate ENaC are associated with hypotension (McDonough, 1998). Canessa, *et al.* showed that epithelial sodium channels are comprised of three homologous subunits, α , β and γ (Canessa et al., 1994). Identification of the ENaC subunits has unveiled a gene superfamily in which individual subunits have a 60-90 % amino acid homology between species. α , β and γ subunits share a 12 % amino acid identity to the degenerin proteins found in the nematode *Caenorhabditis elegans*: MEC-4, MEC-10 and DEG-1, which provides an evolutionary link in this superfamily (Barbry and Hofman, 1997). It was found that mutations of these genes result in cell swelling and this led to the concept that they may be ion channel proteins. The consensus on membrane organization of ENaC is that each subunit has two hydrophobic domains, M1 and M2. A glycosylated extracellular domain comprising 65-70 % of the total amino acid sequence separates M1 and M2 and contains a cysteine-rich box, the function of which may be involved in disulfide bridges in the tertiary structure and a region associated with M2 that confers amiloride sensitivity (Barbry and Hofman, 1997; Voilley et al., 1997). Recently it has been shown that ENaC is a tetrameric channel with an $\alpha_2\beta\gamma$ stoichiometry (Kosari et al., 1998) and further analysis of the membrane organization of ENaC has shown that subunits are attached to cytoskeletal proteins such as actin, α -spectrin and ankyrin proteins (McDonough, 1998; Kosari et al., 1998). It is thought that these cytoskeletal interactions enable ENaC to be sensitive to membrane distension or a change in cell volume and it has been shown that hypertonicity may activate ENaC through a mechanism involving G-actin (Ji et al., 1998). The modulation

of ENaC by hormones such as aldosterone, vasopressin and oxytocin suggests that ENaC is a likely target for phosphorylation. Intracellular amino and carboxy ends of ENaC contain consensus sites for Ca^{2+} -dependent protein kinase (PKC) and casein kinase II phosphorylation. A single cAMP-dependent protein kinase (PKA) phosphorylation site has been found at the carboxy terminal of ENaC isolated from rat, but not from human (Barbry and Hofman, 1997) and the lack of PKA sites in this channel protein suggests that the effect of cAMP may be indirect. Indeed, it has been shown that coexpression of ENaC with the cAMP-dependent cystic fibrosis transmembrane conductance regulator Cl^- channel (CFTR) confers some down-regulatory effects on amiloride-sensitive Na^+ conductance (Stutts et al., 1995). This association of ENaC with CFTR will be discussed further in section 3.5.1.

3.4 Potassium Channels

Basolateral potassium channels in pancreatic duct epithelial cells have three major functions: 1) to hyperpolarize the cell and provide the electrical driving force for HCO_3^- (and Cl^-) secretion at the apical membrane; 2) they allow the exit of K^+ ions from the cell during HCO_3^- (and Cl^-) secretion to maintain electroneutrality; and 3) they provide a leak pathway for K^+ ions that accumulate by the action of Na^+/K^+ -ATPase (Case and Argent, 1993). K^+ channels in the basolateral membranes of pancreatic duct epithelial cells have been identified using patch-clamp methods (Gray et al., 1990b) and by electrophysiological measurements of perfused pancreatic ducts (Novak and Greger, 1988). Structural classes of K^+ channels are based on three topological motifs and variations within these themes are apparent. The three major structural classes of K^+

channels are characterized by voltage-gated channels (K_v), inward rectifier K^+ channels (K_{ir}) and minimum conductance K^+ channels (minK) channels (Breitwieser, 1996).

Further classification of K^+ channels is based on the channel regulatory mechanisms. Ca^{2+} -activated K^+ channels (K_{Ca}) have been characterized in pancreatic duct epithelial cells (Galiotta et al., 1997; Roch et al., 1995; Nguyen et al., 1998b; Nguyen and Moody, 1998a; Gray et al., 1990b). The hallmark of this channel type is the increase in open probability, P_o , in response to an elevation in intracellular Ca^{2+} . K_{Ca} channels are generally divided into sub-groups, according to conductance. Small conductance channels (SK), which have single channel conductances of ≤ 80 pS are characteristically blocked by the bee venom peptide apamin. These K_{Ca} channels can be voltage-dependent or -independent. Intermediate conductance K_{Ca} channels have conductances ranging from 30-60 pS (with equimolar KCl inside and outside the cell membrane) and are insensitive to apamin. Finally, maxi- K^+ channels exhibit voltage-gated conductance in the single channel range of 250-300 pS and are sensitive to charybdotoxin and iberiotoxin. Different classes of K_{Ca} channels have been found in pancreatic duct cells, as in the reports cited above and this may result from species differences and the preparations and methods used by different laboratories. Such differences may be exhibited physiologically by bicarbonate concentrations differing in pancreatic juice from humans, cats, dogs and guinea pigs (Case and Argent, 1993). Activation of K_{Ca} by ATP and UTP binding to P_{2Y2} receptors has been demonstrated together with a concomitant activation in Cl^- secretion (Galiotta et al., 1997; Nguyen et al., 1998b). Regulation of K_{Ca} channels by cAMP-dependent phosphorylation has also been demonstrated in pancreatic duct

epithelia. Stimulation of cells with secretin induced the activation of maxi-K⁺ channels and increased the channel responsiveness to Ca²⁺ (Gray et al., 1990b).

ATP-sensitive K⁺ channels are ligand-gated and couple distribution of charge to the metabolic state of the cell (Shyng et al., 1997). The octameric complex of the K_{ATP} channel constitutes two structurally distinct proteins: an inwardly rectifying K⁺ channel subunit, K_{ir} 6.2 and a sulfonylurea receptor, SUR1 (Trapp et al., 1998). The binding of ATP inhibits the K⁺ conductance through the K_{ir}6.2 subunit without ATP hydrolysis, while the SUR1 subunit utilizes MgADP to activate K⁺ conductance (Shyng et al., 1997). The SUR receptor family is part of the ATP-binding cassette protein superfamily, which also includes CFTR and a recent study has shown that in renal epithelial cells, K_{ATP} is formed from products of K_{ir}1.1a and CFTR genes (Ruknudin et al., 1998). Activation of basolateral K⁺ channels has been shown to hyperpolarize the cell membrane and create an adequate electrochemical gradient for secretion of Cl⁻ (Baro et al., 1994). In a CF pancreatic epithelial cell model, transfected with wild-type CFTR protein, a 35 pS K⁺ channel that was activated by cAMP and also by Ca²⁺, but that was inhibited by Mg-ATP, was found to be the predominant K⁺ channel type. However, in cells displaying the ΔF508 mutated CFTR phenotype, the ability to activate basolateral K⁺ conductance with cAMP was lost (Loussouarn et al., 1996). This demonstrates further how dysfunctional CFTR can lead to a reduction in apical secretion of bicarbonate.

3.5 Chloride Channels

Chloride represents the dominant diffusible anion in most cell types, the rest being associated with organic anion molecules. Thus, chloride channels play an important role in cellular homeostasis under normal and pathological conditions. They are widely

expressed and physiological tasks include cell volume regulation, transepithelial transport, intracellular pH regulation and membrane excitability and signal transduction. Classification may be roughly achieved according to mechanisms of activation, such as channels activated by extracellular ligands, cyclic AMP, G-proteins, voltage and cell swelling. However, problems are encountered as some mechanisms of activation may overlap and final classification will depend on molecular characterization (Jentsch and Günther, 1997). Here, I will describe three well-characterized Cl⁻ channels in epithelial cells and briefly mention some other less investigated chloride channel types.

3.5.1 cAMP-Regulated Cl⁻ Channels

CFTR Structure and Regulation

CFTR is the most extensively studied Cl⁻ channel in epithelial cells and its physiological importance is clearly demonstrated by the loss of fluid homeostasis in CF tissues. The structure of the CFTR protein places it in the ATP-binding cassette superfamily (Fuller and Benos, 1992), which includes bacterial periplasmic transporters, such as the yeast STE6 gene product and the p-glycoproteins (*mdr* gene products). From the model depicted in figure 5, CFTR is predicted to be composed of five domains; two membrane spanning domains, which form the channel pore, two nucleotide-binding folds (NBF1 and NBF2) and the regulatory R domain (Fuller and Benos, 1992). The two membrane spanning domains are both made up of six transmembrane segments each, which together are thought to form the ion channel pore. The permeation of CFTR Cl⁻ channels by halides has been studied using the patch-clamp technique and the single channel Cl⁻ conductance of CFTR is around 8-10 pS (Tabcharani et al., 1997). The

permeability sequence of CFTR is $I^- > NO_3^- > Br^- > Cl^- > HCO_3^- > acetate > F^-$ and this suggests that hydration energies may be responsible for controlling the permeability of CFTR due to increasing size of anions in the sequence (Lindsell et al., 1997; Hanrahan et al., 1998). Pharmacological regulation of CFTR involves blocking by glibenclamide, which also blocks K_{ATP} channels by binding to the sulfonylurea receptor (Sheppard and Robinson, 1997). Blocking of CFTR is achieved by diphenylamine-2-carboxylic acid, but CFTR is insensitive to stilbene derivatives such as 4,4'-diisothiocyanostilbene-2,2'-disulfonic acid (DIDS).

The remaining three domains, two nucleotide-binding folds (NBF1 and 2) and the R domain are involved in regulating channel opening and closing. CFTR is acutely regulated by phosphorylation and most of the affected residues are located on the R domain (Townsend et al., 1996). For CFTR to be in the open state serine residues in the R domain must be phosphorylated by protein kinase A and ATP must bind to NBF1 and 2 and be hydrolyzed (Ma et al., 1997). It has recently been shown that unphosphorylated R domain has inhibitory interactions with CFTR, but stimulates channel opening when phosphorylated (Tasch et al., 1999). Type II PKA has recently been shown to be active in regulating CFTR in pancreatic duct epithelial cells (Steagall et al., 1998). Protein kinase C has also been shown to regulate CFTR channel function and was shown to enhance both the rate and magnitude of subsequent PKA stimulation of open probability (Jia et al., 1997). The PKC-induced increase in CFTR Cl^- conductance in pancreatic duct epithelial cells was proposed to be due to the effect of PKC stabilizing CFTR in the plasma membrane and not by changing the current density (Gray et al., 1995). cGMP-dependent protein kinase (cGKII) expression has been shown to make CFTR sensitive to

modulation by cGMP. However, this mechanism has only been demonstrated in intestinal epithelia (Vaandrager et al., 1997). Dephosphorylation of CFTR causes down regulation of channel activity and the serine and threonine phosphatases 2C and 2A have been associated with CFTR channel deactivation (Luo et al., 1998).

EXTRACELLULAR

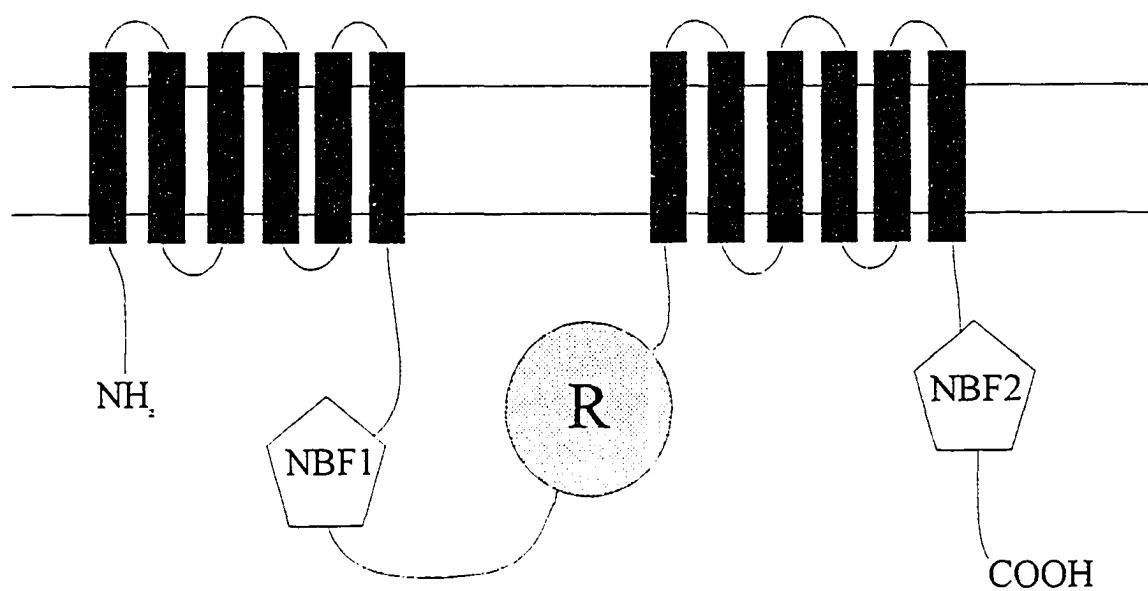

INTRACELLULAR

Figure 5. Transmembrane topology of CFTR. NBF = nucleotide binding fold, R = regulatory domain.

ATP binding and hydrolysis is necessary for full CFTR channel function and this occurs at the nucleotide binding folds. Three regions of conserved, consensus sequences have been characterized in CFTR NBF1 and 2. Firstly, the Walker A motif forms a phosphate binding loop in the hydrolytic core of NBF1 and 2. These motifs are found in ATPases and are involved in the binding and hydrolysis of β and γ phosphates. Secondly, the Walker B motif, also characteristic of ATPase function, contributes to the binding of Mg^{2+} and ATP hydrolysis (Foskett, 1998). Finally, the LSGGQ motif is a conserved sequence in GTP-binding proteins and contains an invariant glycine residue. These domains are the sites of the majority of missense mutations that cause CF (Anderson and Welsh, 1992). Mutations of G551 and G1349 to aspartic acid are both CF mutations and result in decreased binding of ATP and inhibited hydrolysis. Evidence for the ATPase activity of CFTR and its tight coupling to the role in channel gating has recently been reviewed (Foskett, 1998; Bear et al., 1997). However, a recent report has disputed this tight coupling of ATPase activity to channel function (Ramjeesingh et al., 1999). These investigators showed that mutations within the Walker A motifs on NBF1 and/or NBF2 revealed only loose coupling of catalytic activity to channel function. Hydrolytic and non-hydrolytic roles for ATP on CFTR channel opening have been suggested. Hydrolysis-resistant ATP analogs (AMP-PNP and ATP γ S) fail to open prephosphorylated CFTR channels in the sweat duct, but AMP-PNP applied in the presence of ATP increased Cl^- channel conductance (Reddy and Quinton, 1996). Gunderson and Kopito further characterized the coupling of ATP binding with channel function by showing that CFTR channel opening is due to ATP ligand-binding site interaction and channel closing being due to dissociation or hydrolysis of ATP

(Gunderson and Kopito, 1995). New models of regulatory methods emerging involve intracellular pH and cAMP-independent mechanisms. A decrease in intracellular pH has recently been proposed to alter the phosphorylation activation of CFTR and also leads to decreased activity of endogenous phosphatases, which are involved in deactivation of CFTR Cl^- conductance (Reddy et al., 1998). Compounds such as milrinone, genistein, 8-cyclopentyl-1,3-dipropylxanthine (CPX) and calyculin A have been shown to activate CFTR Cl^- conductance by cAMP-independent mechanisms (He et al., 1998), although the regulatory mechanism involved has yet to be elucidated.

Other Functions of CFTR

The function of CFTR as a Cl^- channel is undisputed (Hanrahan et al., 1998; Bear et al., 1992) and in addition it has been suggested to conduct macromolecules such as glutathione (Lindsell and Hanrahan, 1998) and polyatomic anions such as HCO_3^- (Lindsell et al., 1997). Several other regulatory roles for this molecule have also been postulated. Three types of channels: other Cl^- channels, K^+ channels and ENaC are thought to be regulated in some way by CFTR. CF patients exhibit abnormally high Na^+ absorption in airway epithelia and in 1995, it was shown that recombinant ENaC, coexpressed with CFTR in an epithelial cell line, showed a small basal Na^+ current that was inhibited by cAMP. It was suggested from this observation that CFTR is the “switch” that balances the rate of Na^+ absorption and Cl^- secretion in normal airway epithelia (Stutts et al., 1995). Further evidence for ENaC regulation through CFTR came from the loss of cAMP-dependent down regulation of Na^+ conductance when ΔF508 CFTR was coexpressed with ENaC in *Xenopus* oocytes (Mall et al., 1996). The mechanism of regulation was later elucidated to involve direct protein interactions

between the R domain and a section upstream of NBF1 in CFTR (Kunzelmann et al., 1997).

Outwardly rectifying Cl⁻ channels have also been suggested to be regulated by CFTR using coexpression in *Xenopus* oocytes. It was shown that transmembrane domain 1 of CFTR and NBF1 with the R domain were essential for the function of ORCC (Schwiebert et al., 1998). Simultaneous isolation and reconstitution of ORCC and CFTR from bovine tracheal epithelium showed that extracellular ATP and functional CFTR are both required for activation of ORCC (Jovov et al., 1995). It was postulated that CFTR releases ATP in to the apical lumen, which could then bind to purinergic receptors on the epithelial surface and activate ORCC in this manner (Greger et al., 1996b). However, some controversy has arisen in this area of CFTR research and several groups have rejected such a proposal through finding no association of CFTR with ATP conductance. Purified CFTR, reconstituted into lipid bilayers (Li et al., 1996), expression in Chinese Hamster Ovary cells (Grygorczyk et al., 1996) or measurement of ATP movement in association with cAMP-dependent secretion in human nasal epithelial cells (Watt et al., 1998), failed to concur with reports of CFTR involvement in ATP conductance. Recent studies have suggested that CFTR is associated with a distinct ATP channel and that phosphorylation and nucleotide-hydrolysis-dependent gating of CFTR is directly involved in the gating of an associated ATP channel (Sugita et al., 1998; Devidas and Guggino, 1997). Thus, there is currently no consensus concerning the relationship between CFTR and ATP transport.

CFTR has also been linked to the regulation of an inwardly rectifying renal K⁺ channel (ROMK2), of intermediate conductance. Coexpression of ROMK2 with CFTR in

Xenopus oocytes conferred an increase in glibenclamide sensitivity of the K^+ channel (Greger et al., 1996b). However, the underlying mechanism controlling this is unclear. In addition to CFTR's potential involvement in channel regulation, a recent report has demonstrated that CFTR expression in the plasma membrane, but not its Cl^- channel function, is required for Cl^-/HCO_3^- exchange via a DIDS-sensitive anion exchanger (Lee et al., 1999). NBF2 has been implicated in the coupling of CFTR to anion exchange function.

The entire spectrum of cellular abnormalities in CF may be insufficiently explained by the defect of CFTR at the plasma membrane. A role for CFTR in intracellular organelles has also been explored. As mentioned earlier, secreted glycoproteins in CF mucus have been found to have elevated levels of fucosylation and sulfation, but decreased levels of sialylation compared to non-CF glycoproteins (Zhang et al., 1995; Wesley et al., 1983; Dosanjh et al., 1994b). Glycosylation of proteins and lipids takes place in the trans-Golgi complex and are substrate-competitive reactions, dependent on pH (Barasch et al., 1991; Barasch and Al-Awqati, 1992). Mucin sialyltransferase functions at an optimal pH of 5.8, whereas fucosyltransferases and sulfotransferases operate most efficiently at neutral or slightly alkaline pH (Barasch and Al-Awqati, 1992; Barasch and Al-Awqati, 1993). From this a hypothesis was adapted to explain the phenomenon of altered glycosylation of CF mucins, although this was later disproved (see below). The defective acidification hypothesis states that as H^+ is pumped into Golgi compartments by the H^+ -ATPase, a parallel Cl^- conductance is required to maintain electroneutrality within the organelle (Mulberg et al., 1991). Dysfunctional CFTR in the

Golgi membrane, or lack of this Cl⁻ channel, may thus inhibit acidification (Barasch et al., 1991).

The role of CFTR in plasma membrane recycling was proposed in 1992. CF pancreatic duct epithelial cells, transfected with wild-type CFTR showed cAMP-dependent membrane recycling. This was done using horseradish peroxidase as a marker (Bradbury et al., 1992). A possible mechanism has recently been proposed to involve pH regulation of transport vesicles. CFTR may stimulate endosome fusion upon cAMP stimulation and Cl⁻ conductance may allow correct pH regulation within the vesicle (Biwersi et al., 1996). This mechanism is reminiscent of membrane recycling in pancreatic duct cells, where alkaline conditions allow membrane endocytosis (Scheele et al., 1996).

Functional CFTR has been found in intracellular membranes (Bradbury et al., 1992; Pasyk and Foskett, 1995; Biwersi et al., 1996) and there is considerable debate as to whether CFTR contributes to acidification of Golgi compartments. Methods used to develop the defective acidification hypothesis were indirect and relied on trans-Golgi partitioning of weak bases or processing of virus particles (Barasch et al., 1991) thus making it difficult to determine Golgi-specific phenomena. A direct approach however, produced evidence against this hypothesis. Liposomes containing fluorescein- and rhodamine-based indicators were microinjected into living cells. These liposomes selectively fused to trans-Golgi membranes. Ratio-imaging confocal microscopy was then used to assess the pH of trans-Golgi compartment directly (Seksek et al., 1995). Measurements carried out in 3T3 fibroblasts, transfected with wild-type or $\Delta F508$ CFTR showed no variation in endosomal pH using this method (Seksek et al., 1996). Thus, it

cannot be said for certain that altered glycosylation of CF mucins is a result of intracellular acidification defects.

A return to the proposal of CFTR's association with nucleotide permeability might, however, explain abnormal glycosylation patterns in CF. Functional CFTR has been identified in endosomal membranes and the association of CFTR with translocation of 3'-phosphoadenosine 5'-phosphosulfate (PAPS) into the Golgi lumen, is an attractive model to explain CF glycosylation defects (Pei et al., 1996). PAPS is synthesized in the cytoplasm and transported to the Golgi lumen, where it serves as a sulfate donor for protein sulfation (Hirschberg and Snider, 1987; Hirschberg, 1997). In the model proposed by Pasyk and Foskett, CFTR functioning in intracellular membranes would constitute a PAPS "leak" in parallel with the PAPS pump, which transports PAPS into the Golgi lumen. If CFTR were dysfunctional or missing, an increase in PAPS luminal concentration would be of consequence (Pei et al., 1996). That sialylation and sulfation reactions are competitive suggests a possible physiological consequence of defective intracellular CFTR would be altered glycosylation.

Outwardly Rectifying Chloride Channel

Another member of the cAMP-dependent Cl⁻ channel group is the outwardly rectifying Cl⁻ channel, so named due its higher, prolonged single channel conductance at depolarizing voltages (Schwiebert et al., 1994). The ORCC has been characterized in pancreatic duct epithelial cells and displays a single channel conductance of around 20-60 pS that is voltage-dependent (Schoumacher et al., 1990; Becq et al., 1992; Welsh et al., 1989). The non-linear current-voltage relationship and other biophysical properties, together with a high sensitivity to blockade by stilbene derivatives make ORCC distinct

from CFTR (Ward et al., 1991; Welsh and Liedtke, 1986). Cellular mechanisms that regulate ORCC function include PKA- and PKC-dependent phosphorylation (Welsh et al., 1989) and as mentioned earlier the binding of ligands to purinergic receptors and a link to CFTR may also be involved (Devidas and Guggino, 1997; Jovov et al., 1995).

3.5.2 Ca^{2+} -Activated Cl^- Channels

In addition to cAMP, intracellular Ca^{2+} is also an important second messenger involved in regulating Cl^- channels at the apical surface of epithelial cells. The Ca^{2+} -activated Cl^- channel has gained much interest following the development of the CFTR knockout mouse model, which displays CF pathology to varying degrees throughout different tissue types. The airway and pancreas epithelial cells are not as severely affected as intestinal epithelia and this is validated by the presence of an alternative Cl^- channel in murine epithelia (Snouwaert et al., 1992). The Ca^{2+} -activated Cl^- channel (CACC) has hence become an attractive therapeutic target for the treatment of CF in humans.

Biophysical properties of CACC differ from those of cAMP-dependent channels, firstly by their responsiveness to calcium ionophores such as ionomycin. These channels are also insensitive to glibenclamide (a blocker of the sulfonylurea receptor that is part of ATP-dependent K^+ channels and CFTR) but are highly sensitive to stilbene derivatives. Similar to the ORCC, CACC has a strong outward rectification and displays a non-linear current-voltage relationship (Wagner et al., 1991). However, a recent study measuring whole-cell current in a human pancreatic duct cell line (HPAF) showed a linear/slightly outward rectifying relationship, according to the Ca^{2+} concentration in the pipette solution (Winpenny et al., 1998). A major distinguishing feature of CACC is its low conductance of around 10-20 pS (Arreola et al., 1995). Several other groups have also

reported CACC as being a significant contributor to Cl^- secretory pathways in pancreatic duct epithelial cells (Eguiguren et al., 1996; Al-Nakkash and Cotton, 1997; Schoumacher et al., 1990; Warth and Greger, 1993).

Ca^{2+} ionophores such as A-23187 and ionomycin are efficient at increasing intracellular Ca^{2+} ($[\text{Ca}^{2+}]_i$) but were found to be relatively poor at stimulating Cl^- secretion. Carbachol and histamine are both known to elevate $[\text{Ca}]_i$ and were shown to induce an additional increase in transepithelial Cl^- flux in intestinal epithelia (Kachintorn et al., 1997). This led to the understanding that second messengers other than Ca^{2+} are involved in modulating Cl^- channel function (Barrett, 1997). Inositol 1,4,5-triphosphate (IP_3) was later identified as the second messenger which when released from phosphoinositol membrane lipids by phospholipase C, acted to release Ca^{2+} from intracellular stores, allowing the Ca^{2+} -dependent activation of calmodulin kinase (CaMKII) (Xie et al., 1998). This then simulates CACC activity through phosphorylation of the channel protein or a closely associated subunit. Inositol (3,4,5,6)-tetrakisphosphate (IP_4) is a metabolite of IP_3 and has been shown to have inhibitory effects on CACC function. This may act as a negative feedback pathway and must be considered when exploring CACC as a therapeutic target for CF treatment (Vajanaphanich et al., 1994). CACC has also shown to be regulated by intracellular pH. Acidic pH inside the cell causes a reduction in Ca^{2+} -dependent Cl^- secretion and this may be physiologically relevant by having direct consequences on Na^+/H^+ and $\text{HCO}_3^-/\text{Cl}^-$ exchanger function (Arreola et al., 1995). Recent molecular characterization of CACC from the CF mouse model has revealed a sequence homologous to the lung endothelial cell adhesion

molecule, although the physiological significance of this has yet to be elucidated (Gandhi et al., 1998).

3.5.3 ClC Channels

The ClC channels are a family of voltage-gated Cl⁻ channels, with at least eight members named ClC-0 to ClC-7 (Jentsch and Günther, 1997). The ClC genes have been found in yeast (Schwappach et al., 1998), plants (Hechenberger et al., 1996) and mammals (Jentsch and Günther, 1997) demonstrating some evolutionary conservation. The importance of ClC function is, like CFTR, presented by disease when the channel is mutated. Mutations in ClC-1, found in skeletal muscle, results in myotonia (Ponting, 1997) and ClC-5 has been implicated in the formation of kidney stones, in particular hereditary nephrolithiasis (Fisher et al., 1995; Ponting, 1997). Some isoforms of ClC channels are expressed predominantly in one cell type or organ, such as ClC-1 (skeletal muscle) or ClC-5 (kidney) and others are expressed ubiquitously, such as ClC-2 (Thiemann et al., 1992). Functions of ClC channels are associated with stabilizing membrane potential (ClC-1 and ClC-0) (Chen and Miller, 1996). ClC-2 is known to be involved in cell volume regulation by modulating regulatory volume decrease (Jordt and Jentsch, 1997; Xiong et al., 1999) and other members of the ClC family are responsible for transepithelial Cl⁻ transport (ClC-Ka and b, ClC-5) (Jentsch and Günther, 1997). However, the function of other ClC members has yet to be elucidated, due to the inability to functionally express them (Foskett, 1998).

Several recent reviews have described biophysical biochemical properties of ClC channels (Foskett, 1998; Jentsch and Günther, 1997; Pusch, 1996). In this section I will focus on ClC-2 as this has been found to be expressed in epithelial cells of many different

tissue types, including pancreatic duct and acinar cells (Thiemann et al., 1992; Carew and Thorn, 1996). CIC-2 sequencing predicts a 907 amino acid protein and the transmembrane topology depicts a structure comprising 13 hydrophobic domains (D1-D13). D4 and D13 are of intermediate hydrophobicity and therefore are not integrated with the surrounding membrane (Jentsch and Günther, 1997). More work is required to determine the exact topology of CIC channels. Initially CIC-2 was isolated from rat heart and brain, but has also been found in the lung, liver, intestine, kidney and pancreas (Thiemann et al., 1992). In addition to CIC-2 being present in rat pancreas tissue, it was specifically found in a pancreatic duct cell, adenocarcinoma cell line, CFPAC-1, which is derived from a patient with the $\Delta F508$ CFTR mutation and has been used for studies in this thesis (see 'Experimental Procedures') (Thiemann et al., 1992).

Expression in *Xenopus* oocytes allowed biophysical characterization of CIC-2 (Thiemann et al., 1992). A voltage-gated, linear/outwardly rectifying channel with a permeability ratio of $Cl^- = Br^- > I^-$ makes this channel distinct from CFTR, ORCC and CACC. The single channel conductance has been reported to be small, around 2-5 pS (Foskett, 1998). The channel displays partial inhibition by DPC and is insensitive to stilbene derivatives. Thiemann *et al.* observed that CIC-2 remains closed at physiological voltages (between -100 and $+50$ mV) and so suggested that there may be some other mechanism involved in regulating this Cl^- channel (Thiemann et al., 1992).

Regulated volume decrease often involves the activation of membrane K^+ and Cl^- channels and CIC-2 channels expressed in *Xenopus* oocytes were activated by extracellular hypotonicity. Molecular dissection of the gating mechanism involved in this response showed that deletion of residues 16-61 at the amino terminus produces a

constitutively open channel with a linear current-voltage relationship (Grunder et al., 1992). This mutation had similar responses to low extracellular pH, another distinctive regulating factor of ClC-2 (Sherry et al., 1997). It was suggested that the gating mechanism of ClC-2 was compatible with a ball-and-chain model, where an amino-terminal inactivation domain (ball) binds to a cytoplasmic receptor on the channel backbone, causing the channel to close (Jordt and Jentsch, 1997). Sensitivity of ClC-2 to extracellular pH in the physiological range is high and voltage dependence is shifted to more positive voltages (Jordt and Jentsch, 1997). Amino acids 416-419 in the extracellular region have been identified as the pH sensor of ClC-2 and protonation of these residues leads to increased open probability of the Cl⁻ channel (Stroffekova et al., 1998). It has recently been shown that activation of ClC-2 by PKA is dependent on extracellular pH and at low extracellular pH, PKA also increased the open probability of ClC-2 (Stroffekova et al., 1998; Sherry et al., 1997), although not all species types of ClC-2 have consensus sites for cAMP-dependent phosphorylation (Jordt and Jentsch, 1997). Contrary to these observations, in T84 cells (a human intestinal epithelial cell line) a channel resembling ClC-2 is inhibited by cAMP (Fritsch and Edelman, 1996). Stimulation of ClC-2 by acidic, extracellular pH may play a role in maintaining HCO₃⁻ secretion in pancreatic duct epithelial cells.

3.5.4 Volume-Regulated Cl⁻ Channels

Pancreatic duct epithelial cells also display volume-activated Cl⁻ current. These currents can be elicited by hypertonic intracellular solution and show some time-dependence, peaking at about 8 min at 60 mV (Verdon et al., 1995). The characteristic permeability sequence for this channel type is I⁻ > Br⁻ > Cl⁻ > F⁻ and a non-linear current-

voltage relationship shows strong outward rectification. Dideoxyforskolin and tamoxifen inhibit channel function and stilbene derivatives caused a voltage-dependent block (Verdon et al., 1995). Three different classes of single channel measurements have been made, the smallest being 0.1-8 pS, followed by 20-90 pS and large conductance volume-regulated Cl⁻ channels of around 200-400 pS (Nilius et al., 1996). These differences may point to a broad population of volume-sensitive channels.

The primary physiological function of volume-sensitive Cl⁻ channels is regulatory volume decrease. However, under physiological conditions, pancreatic duct epithelial cells are exposed only to secreted HCO₃⁻-rich juice that is isotonic, thus giving no apparent reason for regulated volume decrease (Verdon et al., 1995).

Cell swelling has been reported to induce increases in intracellular Ca²⁺ and calcium release-activated Ca²⁺ channels (CRAC) have been shown to be activated by cell swelling (Nilius et al., 1996). Volume-sensitive channels in pancreatic duct epithelia are dependent on intracellular Ca²⁺, contrary to observations in other tissues and once the channels are activated, removal of Ca²⁺ has no effect. This observation together with a requirement for ATP in activating volume-sensitive Cl⁻ conductance suggests a phosphorylation step may be involved (Verdon et al., 1995). In these studies, PKC was implicated to play some role in channel activation. The molecular identity of the outwardly rectifying, swelling-activated anion channel in pancreatic epithelia and other cell types has yet to be identified. A recent review has labeled ClC2 and ClC3 as the most likely candidates for volume-regulated anion channels (Strange, 1998) due to their direct response to cell swelling.

In summary, the physiological significance of ion channel function can be seen in heritable diseases such as cystic fibrosis (CFTR), familial persistent hyperinsulinemic hypoglycemia (ATP-sensitive K⁺ channel), Liddle's syndrome (ENaC), hypercalciuric nephrolithiasis (Dent's disease; CLC5) and myopathies such as Becker's generalized myotonia (CLC1) all of which are reviewed by (Ackerman and Clapham, 1997). In addition to conventional mechanisms of channel regulation, such as voltage-dependence, cAMP- and Ca²⁺-dependent pathways, G-protein interactions or direct binding of agonists, there are inherent characteristics of channel molecules and their surrounding environment, which play a part in modulation of ion flux across the cell membrane. Such characteristics may be altered during disease, and hence may contribute to a pathophysiologic state. Two of these characteristics of the cell and/channel protein, which play a part in channel regulation during disease, are negative charge on the cell membrane and the redox status of the cell. These two properties will be described in the following sections.

B. Cell Surface Charges and Ion Channel Function

There are many physiological phenomena associated with surface charges on the cell membrane, such as cell adhesion (Nishiguchi et al., 1998; Nagao et al., 1995), migration and metastasis (Riviere et al., 1995) and cell communication (Rieu et al., 1992). Cell surface charge has two significant roles that are of central interest to my thesis: 1) cell adhesion and 2) ion channel function. To understand more about how the coupling of membrane surface charge to cell adhesion and channel function may play a role in

disease states such as CF, the biophysics and biochemistry of this phenomenon will be described here.

1. *The Electrical Double Layer*

Charged surfaces are ubiquitous in biological systems and their contribution to attractive forces between two membrane surfaces during cell adhesion, or between a charged ion in solution and the mouth of an ion channel molecule within a lipid bilayer, can be described by two similar models that are based on similar principles. The interactive potential energy profile between two charged surfaces constitutes the electrical double layer. Long range, Van der Waals forces exert an attractive force between surfaces, but as the two surfaces are drawn together an electrostatic repulsive force becomes dominant. If the surfaces are forced closer together, attractive Van der Waals forces dominate again (Nir and Andersen, 1977; Coakley and Gallez, 1989). The Gouy-Chapman theory of the diffuse double layer and the Debye-Hückel theory are two analogous models in principle. The former of which deals with large planar surfaces, a model that is appropriate for cell membranes, whereas the latter model describes the interactions of electrolytes in solution, where low surface potentials are present on small ions (Jones, 1975; Hille, 1992a). This is most applicable to charge selectivity filters present on ion channel proteins. It must also be considered that the charges present on the cell membrane surrounding an ion channel can also have a significant influence on ion conductance through the channel pore, this will be described later. Both the Gouy-Chapman theory and the Debye-Hückel theory account for the strength of the electric field from an ionized group and how far it extends into solution. In addition, the effect of

potentials around a fixed charge on the local distribution of other mobile ions (permeant ions) is taken into consideration (Blank, 1987).

An electrical double layer is formed when a charged surface comes in contact with a liquid medium. Oppositely charged solutes (counterions) will be attracted to the membrane surface and increase their local concentration (via Van der Waals forces), whereas solutes of like charge (coions) will be repelled (Green and Anderson, 1991). This creates an area of unequal positive and negative ion concentration near the charged surface of the membrane, known as the diffuse electrical double layer (Jones, 1975). The electrical potential falls off gradually with increasing distance from the charged membrane surface (figure 6).

The physiological context, which is of particular relevance to my thesis, is the charge on a cell membrane surface and how this may affect cell adhesion and/or ion channel conductance. Every biological surface and ion in solution has an electrical double layer associated with it. As two charged surfaces approach each other, whether they be two cell membranes (for example; in the case of bacterial adherence to epithelial cells) or ions in solution, moving towards an ion channel in the cell membrane, a force of repulsion is experienced between surfaces as they move closer. The physical principle behind this repulsive force is described in figure 7. As two charged surfaces become closer, due to long range Van der Waals forces so do the associated electrical double layers. Therefore a high concentration of counterions develops in the space between the two surfaces, creating an area of high osmotic pressure. As a result, fluid moves into this space and gives rise to a repulsive force. In addition, as surface charges become closer, electrostatic repulsive forces become stronger. However, this force is overcome by the

higher charge density on the membrane surfaces and ultimately attractive Van der Waals forces become dominant (Jones, 1975).

The potential at the membrane/solution interface (i.e. the electrical double layer) is caused by membrane components such as carbohydrates and proteins, which create negative charge on the extracellular surface. A combination of the diffusion potential of ions in the surrounding solution and the electrical field produced at the membrane/solution interface leads to energetically favorable electrostatic interactions, which enable ion translocation across the membrane (Hille, 1992a). A favorable chemical gradient across the membrane in the presence of an electric field enables ion movement through selective channels in the membrane. The random movement of diffusing ions (Brownian motion) has been described as being analogous to the movements of a flea hopping and when an electric field is applied, diffusion of ions become directed, like a flea hopping in a breeze. Ion flow across the cell membrane depends upon the ion concentration in the surface layer and surface charge exerts its influence by controlling the concentration of ions in the double layer (Blank, 1987). Thus, the chemical nature of ion channel molecule itself can play a significant role in creating charge-selective filters, allowing passage of only particular ions, as too can charges on the cell surface that surround the channel pore (Green and Anderson, 1991).

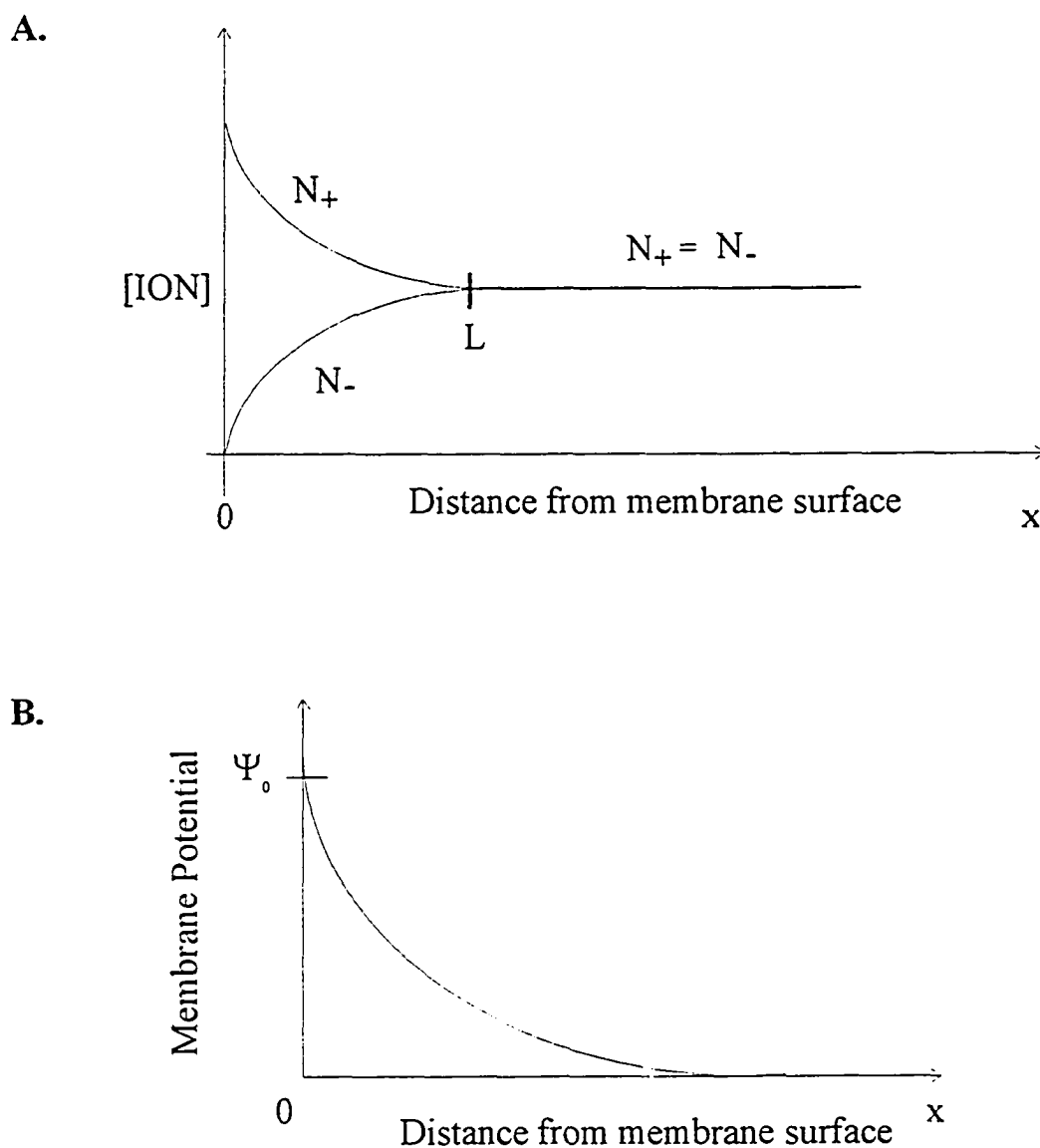

Figure 6. The electric double layer theory. **(A)** Because the membrane is charged (negative), energetically favorable electrostatic interactions mean that positive ions (N_+) are enhanced and negative ions (N_-) are suppressed in the solution near the interface. L marks the thickness of the double layer. **(B)** The membrane potential created by unequal charge distribution, falls off with increasing distance from the membrane surface. Ψ_0 marks the potential at the membrane surface.

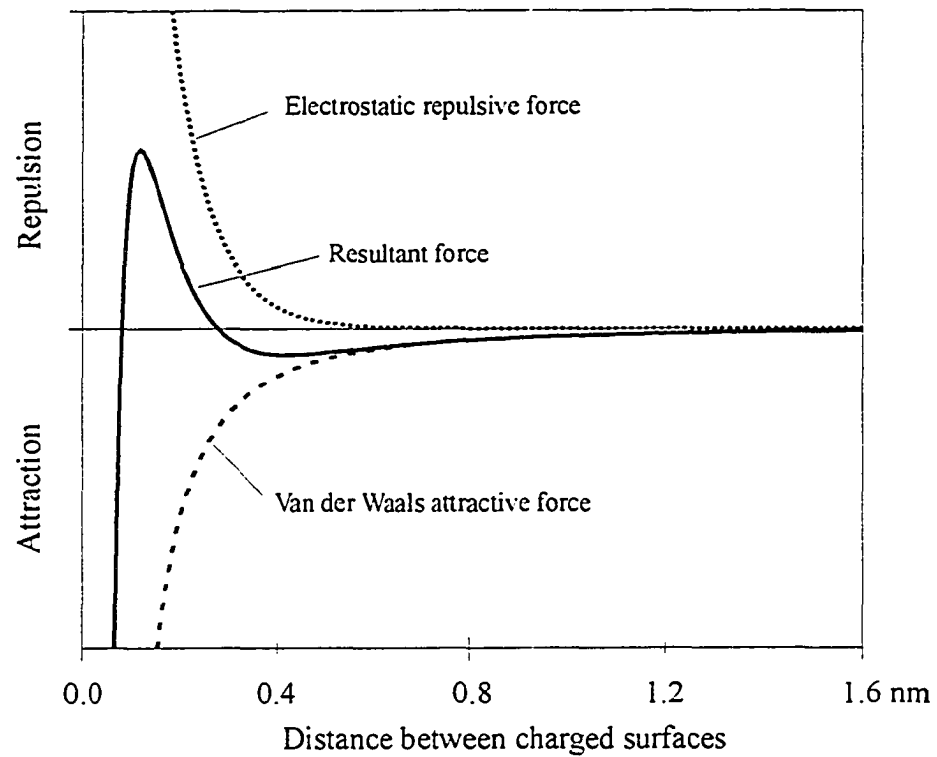

Figure 7. Electrostatic forces between two charged surfaces. A combination of electrostatic repulsive force (dotted line) and Van der Waals attractive force (dashed line) result in an interactive force profile shown by the solid line. As distance decreases, there is an initial attractive force, but high osmolarity created by the presence of ions in the associated electrical double layers and the electrostatic repulsive force creates repulsion between the two charged surfaces. This is overcome as the surfaces move even closer, due to strong, attractive Van der Waals forces.

2. Source and Distribution of Charge

The net negative charge present on the cell membrane is provided by three major components: proteins, sugars and phospholipids and the role of these components in modulating cell-cell interactions and ion channel function will be described here. An understanding of the role of surface charge in cell-cell contact has developed from the net effect of attractive Van der Waals forces and repulsive electrostatic force (Coakley and Gallez, 1989). The magnitude of Van der Waals interactions between cell surfaces has been found to vary with membrane composition (Nir and Andersen, 1977). Changes in chemical composition of the membrane can affect intercellular forces. The magnitude of attractive interactions between cells has been described according to proportional membrane composition: water < phospholipid < cholesterol, protein < sugar. Thus, by replacing a substance with one that is to the left of the sequence, a decrease in magnitude of attractive interactions is observed and vice versa (Nir and Andersen, 1977).

It is thus, the overall combination of charged membrane components and their dispersion over the entire cell surface that contributes to the net effect of surface charge on cell-cell interactions. However, the effect of surface charge on ion channel function can be much more localized and will be described here in terms of charged amino residues, sialic acid residues and charged lipid components. The role of charged amino residues in creating charge selectivity filters within the channel itself, has been described for several channel types. CFTR has been shown to possess arginine residues, which create positive charge in the sixth membrane-spanning segment and form an anion selectivity filter in the channel pore. This site, determining anion vs. cation selectivity, was shown to be near the cytoplasmic end of the channel pore and favored anions by

about 25-fold over cations (Cheung and Akabas, 1997). Voltage-dependent sodium channels from rat skeletal muscle have recently been shown to possess glutamate and aspartate residues within the channel pore. It was suggested that these negatively charged residues form ion-specific binding sites within the pore (Chiamvimonvat et al., 1996). Another example of charge selectivity by channel protein residues is demonstrated by the ryanodine receptor (RyR) linked to cardiac sarcoplasmic reticulum Ca^{2+} release channels. Negative surface charges, in the form of carboxyl groups near the luminal mouth of the channel, potentiate conductance by increasing the local Ca^{2+} concentration (Tu et al., 1994). Similar results have been reported for the Ca^{2+} -activated K^+ channel (MacKinnon et al., 1989).

Sialic acid is a negatively charged molecule and appears on the membrane surface mostly in the polysialic acid moiety. These large polymers can make a sizeable contribution to the net cell surface charge and this has significant impact on ion channel function (Green and Anderson, 1991) and cell adhesion (Nir and Andersen, 1977; Kelm and Schauer, 1997). Removal of polysialic acid residues from eel electroplax sodium channels reconstituted in planar lipid bilayers, causes a large shift in the average midpoint potential of channel activation and an increase in the frequency of subconductance states (James and Agnew, 1987; Recio-Pinto et al., 1990). Similar results were observed in a recent study by expressing rat skeletal muscle sodium channel in a sialylation-deficient cell line (*lec2*) (Bennett et al., 1997). Although the exact role of these sialic acid moieties is unknown, several possibilities have been proposed. If resting membrane potential is usually negative, then by decreasing the negative charge near the channel molecule, the functional effect is to hyperpolarize the membrane. An increased depolarizing stimulus is

then required to activate the channel. Similar effects of channel sialylation have been observed in the Kv1.1 delayed rectifier K⁺ channel (Thornhill et al., 1996), although earlier reports showed that while sialic acid residues contribute to negative surface charge, they are not associated with the channel protein (McDonagh and Nathan, 1990; Fermini and Nathan, 1990). These initial studies used delayed rectifier K⁺ channels in myocytes as compared to expression in the *lec2* cell line (Thornhill et al., 1996) and this may account for discrepant results.

The functional importance of sialylation and glycosylation on the membrane surface can be seen in patients affected with diseases resulting in reduced protein glycosylation (Koscielak, 1995) and this may be of significance in cystic fibrosis. As mentioned earlier, altered glycosylation of secreted mucin glycoproteins has been identified as a characteristic of CF (Dosanjh et al., 1994a). It is not known, however, if membrane-linked glycoproteins are also affected in this manner and this is a key question to be addressed by my thesis. Unlike amino acids and sialic acid residues, phosphate groups are transient fixtures on or around the surface of ion channels (Green and Anderson, 1991). The functional effect mostly associated with phosphorylation of channel proteins is a conformational change. However, it has also been shown that the addition of phosphate residues to the delayed rectifier K⁺ channel in squid giant axons, results in a shift in its voltage dependence (Perozo and Bezanilla, 1990). The investigators concluded that this was due to electrostatic interactions between the channel voltage sensor and phosphate group transferred from ATP, due to a measured increase in surface charge density in the presence of hydrolyzable ATP.

Charged lipids in the membrane bilayer can contribute to net surface charge and thus affect channel function (Green and Anderson, 1991). Electrostatic effects of negatively charged lipid bilayers have been shown to cause a voltage shift on the gating curve of voltage-dependent sodium channels, but this was only seen at low ionic concentrations (Cukierman, 1991). Similarly, K⁺ channels from sarcoplasmic reticulum, reconstituted into negatively charged bilayers showed increased single-channel conductance, which was decreased in positively charged bilayers (Bell and Miller, 1984). The prominent observations at low ionic concentrations in both these studies suggests that the negative charge on the lipids is involved in concentrating the permeant ion at the mouth of the channel or that the voltage sensor lies close to the lipid bilayer (Green and Anderson, 1991). Electrostatic interactions of phospholipid head groups in lipid monolayers has recently been shown to affect membrane curvature and this in turn is capable of influencing channel protein conformation in a lipid membrane. It was shown that by decreasing electrostatic repulsion among phosphatidylserine head groups, the stability of gramicidin channels in such membranes was disrupted (Lundbaek et al., 1997).

Lipid peroxidation is a chain reaction, which results in the oxidative deterioration of polyunsaturated lipids in cell membrane (Halliwell and Gutteridge, 1989). This process is initiated by the action of a species with sufficient reactivity so as to extract a hydrogen atom from a methylene group.

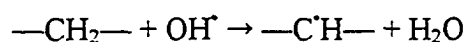

Free radical species such as hydroxyl radical (OH[•]) or nitric oxide (NO[•]) are capable of such a reaction and are present in cystic fibrosis epithelial cells under oxidative stress (Portal et al., 1995). The hydrogen abstraction by free radical species propagates a series

of oxidative reactions and ultimately leads to the formation of lipid hydroperoxides (Halliwell and Gutteridge, 1989). This radical chain reaction in the cell membrane has been shown to decrease negative surface charge (Ohyashiki et al., 1993) and therefore must be considered as a potential regulator of ion channel function (Kourie, 1998). In addition it has been shown that membranes exhibiting a more positive surface charge are more susceptible to lipid peroxidation (Sassa et al., 1994). This is of particular interest to my studies presented here, when the possible reduction of negatively charged sialylated proteins seen in CF is considered (Dosanjh et al., 1994a).

C. Nitric Oxide and Ion Channel Function

Nitric oxide (NO) is a highly reactive, lipophilic gas and physiologic concentrations are usually in the region of 0.1-2 μM . NO is an extremely important and versatile messenger in many biological systems and has been extensively studied in many tissue types. In 1987, NO was first identified as having identical properties to endothelium-derived relaxing factor (EDRF) (Palmer et al., 1987). Since then it has been shown to exert a multitude of biological actions such as regulation of vascular tone and integrity, neuromodulation, or when released in high quantities NO can provoke cytotoxic actions leading to tissue injury and inflammation (reviewed by (Whittle, 1995)). In the pancreas, NO has a wide variety of roles, from acting as a neurotransmitter in regulating secretory processes (Vaquero et al., 1998), to being secreted as a cytotoxic factor in the immune system during pancreatic inflammation (Al-Mufti et al., 1998). Here, I will briefly review

the physiological chemistry associated with NO and its role in regulating ion channel function.

1. The Nitric Oxide Biosynthetic Pathway

A ubiquitous family of nitric oxide synthase enzymes (NOS) catalyzes NO production by the oxidation of L-arginine. Three distinct isoforms of NOS are classified according to their localization and their Ca^{2+} dependence. All isozymes are products of distinct genes on different chromosomes (see table 1). Neuronal NOS (nNOS/NOS I) is mostly located in excitable tissue. Inducible NOS (iNOS/NOS II) was originally located in macrophages and was shown to be up-regulated during an inflammatory response (Lyons, 1995). Endothelial NOS (eNOS/NOS III) as the name implies, was originally discovered in endothelial tissue of the vascular system and is constitutively expressed, as is nNOS (Radomski and Salas, 1995).

Table 1. Characteristics of NOS isoforms.

	nNOS/NOS I	iNOS/NOS II	eNOS/NOS III
M_r (kDa)	160	130	133
Ca^{2+} dependent	YES	NO	YES
Subcellular Distribution	Soluble	Soluble	Membrane Bound

The mechanism of NO synthesis involves the participation of four cofactors, namely heme, flavin adenine dinucleotide (FAD), flavin mononucleotide (FMN) and tetrahydrobiopterin. Cosubstrates involved in the enzyme-catalyzed oxidation of L-arginine include O_2 and NADPH. The presence of a heme-binding moiety near the amino-terminal of NOS can lead to inhibition of NO production through binding of CO, or

via an autoinhibitory feedback loop through NO binding. For a detailed review of NOS structure, function and pharmacological regulation, I refer the reader to (Mayer and Andrew, 1998).

NO is involved in a wide variety of biochemical reactions and exhibits protective, regulatory and deleterious roles in many tissue types. Examples of molecules targeted by NO through direct or indirect action are summarized in figure 8. Soluble guanylate cyclase and thiol-containing proteins are biological targets of NO and mechanisms by which NO modulates their activity, apropos of ion channel function is of central interest to this thesis.

Three different forms of NO can influence its biological targets and action (Stamler et al., 1992). The nitrosonium cation (NO^+), nitric oxide (NO^\bullet) and the nitroxyl anion (NO^-) are interrelated redox forms and can be interconverted with the involvement of transition metal nitrosyl complexes, this will be described in further detail in section 3. This can lead to direct reactions with Fe(II)- and Fe(III)-containing metalloenzymes (Feelisch, 1998). In addition, NO^\bullet can have indirect effects by reacting with reactive oxygen species such as O_2 and the superoxide radical anion O_2^- giving rise to oxidativative, nitrative and nitrosative reactions. Coupling to thiol/disulfide redox reactions, and direct actions with metalloenzymes are an important mechanisms by which NO can regulate ion channel function, and will be focused on in this section (Stamler et al., 1992). Figure 8 gives an overview of direct and indirect actions of NO.

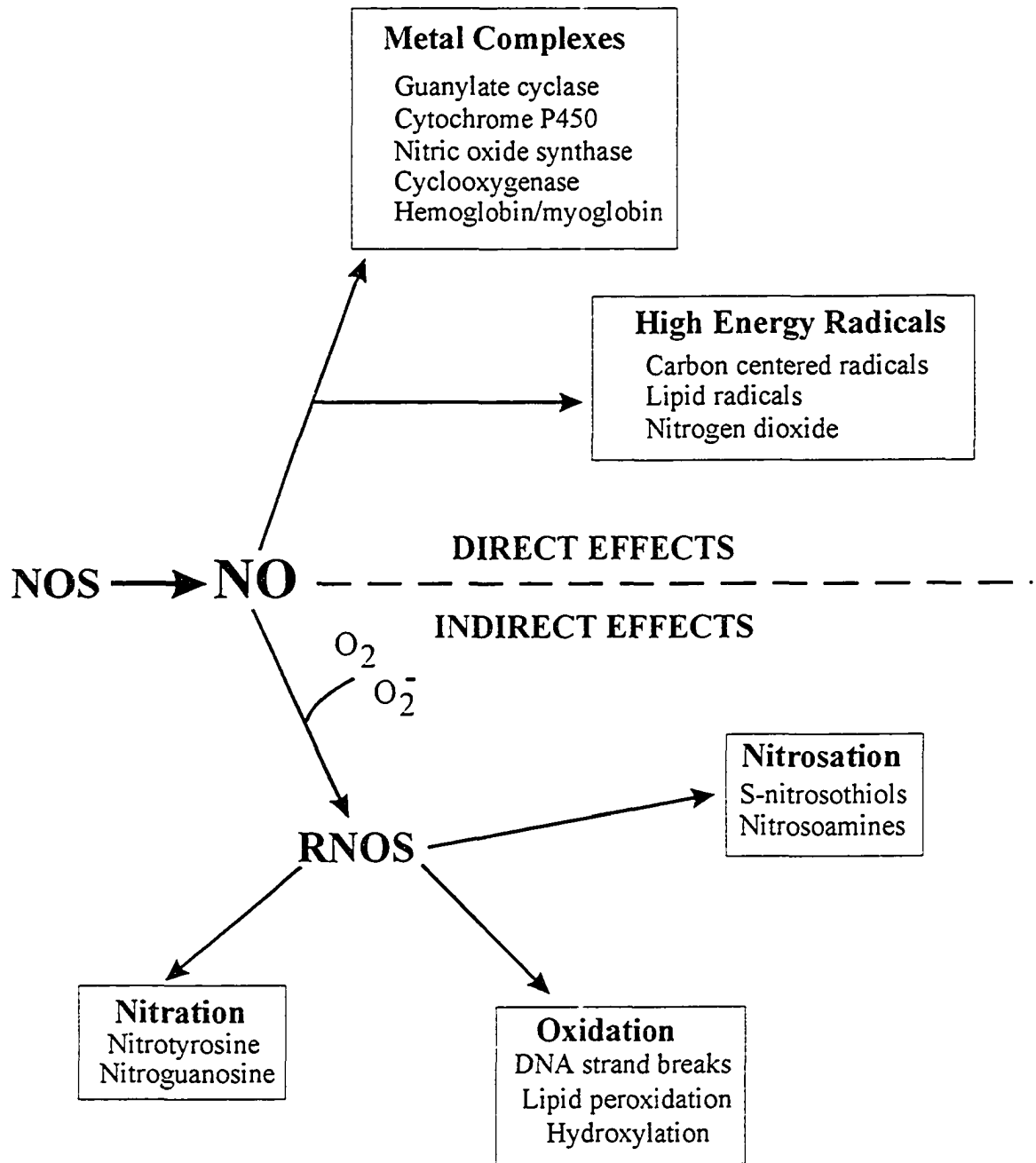

Figure 8. The physiological effects of NO depend on its redox form. Effects diversify between direct interactions with metal nitrosyl complexes and high energy free radicals and indirect effects through formation of reactive nitric oxygen species (RNOS). Modified from (Grisham et al., 1999).

2. Nitric Oxide and Cyclic GMP

The most notable reaction of NO with metal nitrosyl complexes is that with soluble guanylate cyclase (GC-S). This heterodimeric enzyme catalyzes the conversion of GTP to guanosine cyclic 3',5'-monophosphate (cGMP) in the presence of Mn^{2+} and Mg^{2+} . The binding of NO to the heme group on GC-S causes a change in enzyme conformation and exposes the GTP active site (Schmidt et al., 1993; Hobbs, 1997). cGMP plays a central role in many signaling mechanisms involved in ion channel regulation and interacts with three main classes of proteins: 1) cGMP-dependent ion channels, 2) cGMP-dependent protein kinases and 3) cGMP-dependent phosphodiesterases (Lincoln and Cornwell, 1993).

2.1 Cyclic nucleotide-gated channels

Cyclic nucleotide-gated (CNG) channels form a family of closely related proteins, originally detected in photoreceptors and neurons in the olfactory epithelium (Zufall and Leinders-Zufall, 1997) and have since been found in non-sensory cells (Schwiebert et al., 1997; Biel et al., 1998). Two classes of subunits have been identified and native CNG channels are found as homologous tetramers of α subunits or heterologous $\alpha\beta$ complexes (Biel et al., 1998). Three different α subunits have been found (CNG1, 2 and 3) and form ligand-gated cation channels. The two identified β subunits (CNG4 and 5) confer increased cAMP affinity and single-channel flickering properties when coexpressed with α subunits (Bucossi et al., 1997). General properties of CNG channels include a single channel conductance of 15-30 pS that is voltage-independent, has low selectivity between Na^+ and K^+ and mostly conducts Ca^{2+} . Ca^{2+} -calmodulin binding has been shown to inhibit CNG channels by binding to α or β subunits and it is thought that this may serve

as a negative feedback loop to regulate Ca^{2+} entry in non-sensory cells (Biel et al., 1998). Like cGMP-dependent protein kinases, the binding of cGMP activates CNG channels and some sequence homology exists between the nucleotide binding sites of these two proteins (Biel et al., 1998). Pharmacological regulation of CNG channels includes selective block by diltiazem and variable sensitivity to amiloride (Bucossi et al., 1997).

The importance of NO in regulating CNG channels can be seen through the ability of NO to activate GC-S, thereby increasing intracellular cGMP levels and thus causing activation of these non-selective cation channels. CNG1 has been found recently, in lung epithelia (Schwiebert et al., 1997). Here, it was demonstrated that increased intracellular cGMP stimulated transepithelial ion transport by activating Na^+ conductance through CNG1, which led to a concomitant increase in Cl^- secretion. The presence of CNG channels in exocrine epithelia creates a potential regulatory mechanism, which may be targeted by NO. For example, some odorants cause Ca^{2+} stimulation of NOS in olfactory epithelia and the resulting diffusion of NO leads to GC-S activation in olfactory neurons, which leads to further increases in Ca^{2+} through CNG channels (Schmidt et al., 1993).

2.2 cGMP-dependent protein kinase

The two identified types of cGMP-dependent protein kinase are important mediators signal transduction initiated by NO and phosphorylation is known to be a key process in regulating ion channel function (Lincoln et al., 1996). Soluble type I (GKI) protein kinase is a 76 kDa protein and is distributed throughout many tissue types and highest concentrations of this isoform have been found in cerebellar purkinje cells, smooth muscle cells and platelets (Schmidt et al., 1993). The membrane-bound form, GKII, (86 kDa) has predominant localization in epithelial cells and is of particular interest to my

studies presented here. Expression of this isoform has specifically been associated with stimulating CFTR-dependent Cl^- secretion in a GKII-deficient intestinal cell line (Vaandrager et al., 1997). In addition, GKII knockout mice display selective loss of cGMP-dependent Cl^- secretion (Lohmann et al., 1997). GKII has also recently been identified in the kidney, brain and bone (Lohmann et al., 1997). The role of GKII in ion channel regulation may be attributed to its association with the plasma membrane and close proximity to ion channel proteins (Lincoln and Cornwell, 1993).

NO has been shown to modulate ion channel activity through the activation of cGMP-dependent protein kinase in several different systems. As mentioned above, intestinal Cl^- secretion can be stimulated by GKII-dependent activation of CFTR. Similarly, a housekeeping Cl^- channel in rabbit gastric parietal cells is activated by a signaling cascade involving prostaglandin-induced increases in intracellular calcium. This then activates Ca^{2+} -dependent NOS isoforms and leads to NO-induced activation of GC-S. The resulting increase in cGMP activates a small (0.4 pS) basolateral Cl^- channel in the parietal cell, thus determining the membrane potential (Sakai et al., 1995). The NO/cGMP-dependent protein kinase mechanism can cause channel inhibition as well as activation. In rat type II pneumocytes, the application of NO reduced mean open times of a predominant cation channel with a single channel conductance of 20 pS (Jain et al., 1998). The mediation of this mechanism by cGMP-dependent protein kinase was identified by the use of KT-5823, a blocker of these protein kinases. Also in the airway, in CF mouse nasal and tracheal epithelium, tonic regulation of amiloride-sensitive Na^+ absorption was shown to be regulated by basal cGMP levels and respective protein kinase activity (Kelley et al., 1998a). The reabsorptive process linked with the amiloride-

sensitive Na^+ channel in airway epithelia appeared to increase when guanylate cyclase and cGMP-dependent protein kinase were inhibited, suggesting that secretory processes may be elevated when GC-S is stimulated. This corroborates with a previous study from our laboratory where NO applied to a human type II pneumocyte cell line, which does not express CFTR, stimulated Cl^- current via a cGMP-dependent mechanism (Kamosinska et al., 1997). Thus the NO/cGMP pathway may be prognosticated as a potential therapeutic target to stimulate mucus secretion in CF epithelia.

Protein phosphatase activation by cGMP may also result in modulation of channel activity in some cell types. In rat pituitary tumor cells (GH_4C_1), large conductance, Ca^{2+} -activated, voltage-gated K^+ channels (BK_{Ca}) were stimulated by atrial natriuretic peptide and cGMP-dependent protein kinase activity was implicated in this phenomenon (White et al., 1993). cGMP-dependent kinase was suggested to activate protein phosphatase, thus leading to channel activation by dephosphorylation of the channel protein. In contrast, cGMP-induced protein phosphatase activity in mesangial cells from human kidney, causes inhibition of BK_{Ca} channels (Sansom et al., 1997). cGMP-dependent kinase was implicated in the activation of such channels, whereas channel inhibition was attributed to protein phosphatase isoforms.

2.3 Cross-talk pathways

A multiplicity of signaling pathways is opened up when NO stimulates the activity of GC-S and elevates intracellular levels of cGMP. Relative levels of cAMP, cGMP and intracellular Ca^{2+} can orchestrate the impact of protein kinase, phosphatase and phosphodiesterase activity within the cell and visa versa. Multiple forms of phosphodiesterases (PDE) and protein kinases exhibit different affinities for cGMP,

cAMP and Ca^{2+} . This enables the cell to tailor its responsiveness to a particular second messenger (Houslay and Milligan, 1997).

Calcium is a ubiquitous second messenger and so can have significant effects on a variety of cellular processes. A negative feedback system has been suggested between $[\text{Ca}^{2+}]_i$ and cGMP in pancreatic and colonic epithelia. Activation of NOS by depletion of $[\text{Ca}^{2+}]_i$ stores activates calcium entry into the cell via cGMP pathways (Milbourne and Bygrave, 1995; Bischof et al., 1995; Xu et al., 1994). It has been shown by these studies that Ca^{2+} entry appears to be inhibited when high concentrations of cGMP are present, and activated at lower concentrations. Two possible mechanisms of regulation are currently accepted: 1) Ca^{2+} entry can be regulated by cGMP directly through cyclic nucleotide gated ion channels, 2) regulation occurs indirectly through a signaling pathway involving NO. cGMP is known to activate the Ca^{2+} -ATPase pump in the endoplasmic reticulum membrane via cGMP-dependent protein kinase, and also inhibits depletion of Ca^{2+} from intracellular stores by inactivating the IP_3 receptor, thus decreasing Ca^{2+} release into the cytoplasm (Milbourne and Bygrave, 1995). NO may also affect Ca^{2+} release from intracellular stores by direct activation of cyclic ADP-ribose (cADPR) hydrolase. This decreases the cADPR available for activation of ryanodine receptors on endoplasmic reticulum membranes, thus decreasing Ca^{2+} release (Lee, 1994; Clementi and Meldolesi, 1997). cGMP also serves as an intermediate in this mechanism of $[\text{Ca}^{2+}]_i$ regulation by activating cGMP-dependent protein kinase to phosphorylate ADP-ribocyclase, thus increasing the levels of cADPR available for activating ryanodine receptors and consequent Ca^{2+} release.

cAMP is another important second messenger that, like cGMP, has been associated with intracellular signaling pathways that regulate Ca^{2+} mobilization within the cell. As mentioned earlier, cGMP-dependent protein kinase can inhibit Ca^{2+} release from intracellular stores by phosphorylation of inositol triphosphate receptors. cAMP is also capable of modulating Ca^{2+} release by this mechanism (Milbourne and Bygrave, 1995). Other interactions between $[\text{Ca}^{2+}]_i$ and cAMP involve phosphorylation of Ca^{2+} -calmodulin-dependent phosphodiesterase isoforms by cAMP-dependent protein kinase. This phosphorylation is blocked by Ca^{2+} and calmodulin and reversed by calmodulin-dependent phosphatase. This mechanism of Ca^{2+} -cAMP crosstalk is reviewed by (Sharma and Kalra, 1994). $[\text{Ca}^{2+}]_i$ regulation has repercussions on the production of NO inside the cell as the constitutive isoforms of NOS are Ca^{2+} -dependent. Thus an increase in $[\text{Ca}^{2+}]_i$ may result in an increase in NO (Clementi and Meldolesi, 1997).

Cyclic nucleotide phosphodiesterases (PDEs) provide a pivotal route for crosstalk regulation of cAMP signaling by cGMP. An increase in cGMP levels can be a means of elevating or decreasing the activity of cAMP pathways, by regulating levels of cAMP through particular PDE isoforms. PDE2 has a specific binding site for cGMP, which stimulates catalytic activity to decrease intracellular cAMP. This isoform also has a binding site for cAMP and so depends on the competitive binding of the two cyclic nucleotides at the active site. In contrast, PDE3 cGMP is an extremely potent competitive inhibitor of this cAMP-specific isoform. Thus increased levels of cGMP promote an increase in cAMP levels. The activities of PDE isoforms are reviewed by (Houslay and Milligan, 1997). Clinical studies have shown that the inhibition of PDE isoforms blocks the release of proinflammatory cytokines in inflammatory cells. The inhibition of PDEs

may down regulate the NO/cGMP signaling pathway and may also have subsequent effects on epithelial cells where NO increases cGMP levels during inflammation, thus inhibiting cGMP-dependent regulatory processes in epithelial cells (Wright et al., 1998).

The consequences of increasing NO in epithelial cells can be seen to have extensive and potentially complicated actions on cellular functions. By increasing cGMP, the major effector molecule, a whole range of second messenger systems can be affected. cGMP, cAMP, cADPR and $[Ca^{2+}]_i$ are all capable of regulating epithelial permeability by direct modulation or by activation/inhibition of protein kinases which may then modulate the activity of ionic conductances.

3. Redox Modulation of Ion Channels

The redox-specific effects and inconsistent observations of ion channel function modulated by NO have led to the more detailed analysis of NO physiological chemistry. The reactivities of redox related forms of NO (NO^+ , NO^\bullet , NO^-) as discrete species or as biological equivalents have important consequences in physiological regulation of protein function, as described in figure 8 (Arnelle and Stamler, 1995). Nitration reactions involving NO^\bullet can have severe consequences on kinase-dependent reactions and subsequent signaling pathways (Grisham et al., 1999). However, oxidative and nitrosative events have been postulated to induce differing consequences on protein function to those produced by nitration reactions (Xu et al., 1998). Figure 9 summarizes the redox-dependent derivatives of NO produced from NOS within the cell. It can be seen from this figure that the presence of NO^+ , NO^- and their biological equivalents depends on the presence of other redox intermediates. Such intermediates include superoxide anions (O_2^-), hydrogen peroxide (H_2O_2) and nitroso compounds such as S-nitrosoglutathione

(GSNO). Interconversion between redox forms of NO depends on the presence of metal ions, which are capable of charge transfer reactions (e.g. $\text{Cu}^{2+}/\text{Cu}^{3+}$ and $\text{Fe}^{2+}/\text{Fe}^{3+}$) as shown in figure 9. An increase in levels of NO, through release during inflammation (Freeman, 1994), or by pharmacological addition with NO donor compounds (Feelisch, 1998) causes a change in the redox balance within the cell. The potency of NO nitrosative/oxidative action may depend on the presence of antioxidants such as glutathione, or the presence of other reactive oxygen species such as O_2 and O_2^- . Molecular targets underlying the oxidative/nitrosative effects of NO (as shown in figure 8) include, membrane phospholipids (Rubbo and Freeman, 1996), thiol groups and disulfide bonds (Singh et al., 1996). Lipid peroxidation has been described above and is also been shown to lead to changes in ion transport (Kourie, 1998).

Nitrosation reactions coupled with accelerated oxidation of vicinal thiols is the main mechanism by which NO has been suggested to regulate protein function and S-nitrosoglutathione probably acts as a regulatory intermediate (Singh et al., 1996; Arnelles and Stamler, 1995). The addition of covalent attachments as a means of modulating protein conformation and hence function, is reminiscent of phosphorylation processes. S-nitrosothiols have the generic formula of RSNO and the transfer of NO from RSNO to protein thiol groups (transnitrosation) confers responsiveness of ion channels to NO (Kourie, 1998). This transnitrosation process has been demonstrated in vitro by the use of NO donor molecules such as GSNO and S-nitrosopenicillamine (SNAP) in the presence of thiol groups (Singh et al., 1996). A simplified transnitrosation reaction is as follows:

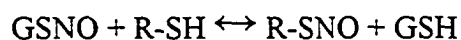

If two equivalents of thiol are present, then disulfide bridges can be formed (GSSG). The decomposition of GSNO can be accelerated if reactive thiol groups such as cysteine are present (Arnelle and Stamler, 1995). Regulation of ion channel function by nitrosylation has been demonstrated in several different systems. Most recently Xu et al. (Xu et al., 1998) observed that poly-S-nitrosylation reversibly activates the cardiac Ca^{2+} release channel (ryanodine receptor). However, further oxidation of thiols to form disulfides leads to irreversible activation and is thus deleterious to the cell. Conversely, Ca^{2+} -activated non-selective cation channel activity in brown adipose tissue was inhibited by a nitrosylation reaction similar to that described above (Koivisto and Nedergaard, 1995). In pancreatic B cells, voltage-dependent Ca^{2+} channels are inhibited by application of RSNO compounds as are ATP-sensitive K^+ channels, but an initial activation of this channel type was observed followed by channel inhibition (Krippet-Drews et al., 1995). NO-induced inhibition of K_{ATP} channels was proposed to be through the inhibition of metabolic pathways, causing a decrease in cell ATP, whereas activation occurs through transnitrosation (Tsuura et al., 1994; Kourie, 1998).

A final point worth mentioning is the physiological role of glutathione as an antioxidant in many cell types. Scientific and medical interest in glutathione (GSH) as a protective mechanism against free-radical mediated injury has grown in recent years and intracellular levels of GSH are crucial in maintaining an appropriate redox status (Sciuto, 1997). Concentrations of this tripeptide, range from μM to mM , being in the higher range in tissues that are subject to potential situations of oxidative stress on a regular basis, e.g. lungs, kidney and liver. In the exocrine pancreas, and also other tissues, the endogenous enzymes, γ -glutamylcysteine synthetase and γ -glutathione synthetase catalyze the

synthesis of GSH (Neuschwander-Tetri et al., 1997; Sciuto, 1997). The primary function of GSH is to form conjugates with reactive electrophiles creating non-toxic, excretable forms. The reaction of GSH with NO free radicals can lead to the formation of GSNO and consequently this is an important cellular source of NO in transnitrosation and other oxidative processes (Singh et al., 1996; Singh et al., 1996). The ratio of reduced:oxidized glutathione (GSH:GSSG) is an indicator of the cell redox state and two mechanisms of GSNO decomposition leading to the formation of GSSG occur:

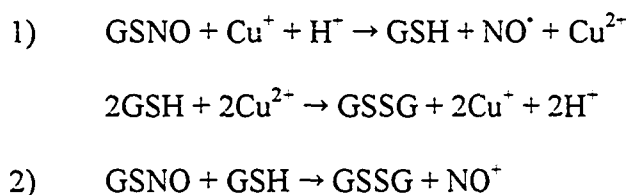

Reaction 1 relies on the presence of metal ions capable of transferring charge from NO to form the free radical NO[•] anion. In reaction 2, NO⁺ is formed if other thiol groups are present. NO[•] is the final product in the absence of metal ions or other thiol groups (heterolytic decomposition). However, the physiological role for this redox form has not been established, thus reaction 2 shows only NO⁺ (Arnelle and Stamler, 1995). These reactions demonstrate the ability of GSH to act in a buffering capacity to release or absorb NO as required in order to prevent oxidative stress inside the cell and the participation of GSH in nitrosative/oxidative reactions bears some significance in redox regulation of ion channel function.

Chapter II.

Rationale and Research Objectives

A. Rationale

Defective cAMP-dependent Cl^- secretion in CF pancreatic epithelia leads to an inhibition of HCO_3^- secretion into the ductal lumen. The concomitant dehydration and fall in fluid pH in the lumen is detrimental to the transfer of digestive enzymes from the pancreas to the intestinal tract. Ductal blockage by the acid-induced precipitation of digestive enzymes then leads to inflammatory states within the pancreas and pancreatitis is a common consequence of such tubulopathy. The redox status in the inflamed pancreas has been shown to be unbalanced, with an increase in free radicals produced mainly by neutrophilic inflammation. Elevated NO levels are common in pancreatitis and clinical approaches to combat such pathology now include antioxidant therapy.

Due to the complexity with which CF manifests itself in epithelia of diverse tissue distribution, it has become apparent that the severity of CF in particular tissue types may involve other factors in addition to apical CFTR dysfunction. Cellular dysfunctions that may be secondary to defective CFTR may act synergistically to accelerate or enhance the development of the CF phenotype. As ion channel function is fundamental to the pathophysiology of CF, my thesis will address two potential mechanisms of ion channel regulation: 1) negative surface charge and 2) nitric oxide and present how these factors may be affected by the pathophysiology of the CF pancreas.

CFPAC-1 and PANC-1 are human pancreatic duct adenocarcinoma cell lines, the former of which is derived from a CF patient displaying the ΔF508 CFTR mutation (Madden and Sarras, 1988; Schoumacher et al., 1990). Ductal epithelial cells comprise only about 5-10 % of the pancreatic mass and are buried within the acinar tissue (Cotton and Al-Nakkash, 1997). Consequently it is difficult to obtain primary cultures of homogenous cell populations for physiological studies. The availability of such samples

from human donors is rare, therefore many investigators use cell lines of ductal carcinoma origin as a model of pancreatic duct epithelia (Winpenny et al., 1998). Both cell lines mentioned above express little or no CFTR mRNA (Madden and Sarras, 1988; Schoumacher et al., 1990), thus making them good models for investigating Cl⁻ secretory pathways alternative to CFTR. If indeed there are additional factors that contribute to CF other than CFTR, these may be investigated more clearly in the absence of the CFTR protein.

B. Objectives

1. To quantify the negative surface charge on pancreatic duct epithelia and to identify any differences between CF and non-CF cells. Negative charges on the cell membrane may influence secretory processes by altering the membrane potential or by direct interaction with ion channel proteins and diffusing ions.
2. To investigate if sialylation of CF membrane-bound glycoconjugates is decreased as compared to those of non-CF cells. Sialic acid has previously been shown to be a major contributor in the regulation of ion channel function and selectivity. Decreased levels of terminal sialylation have been found in secreted CF mucins.
3. To assess the effects of nitric oxide on whole-cell current in duct epithelia and to determine any response differences between CF and non-CF cells. NO is a known modulator of ion channel function in epithelial cells and is present in high levels during inflammation of the pancreas.
4. To identify channel types that are targeted by the action of NO in CF epithelia. The use of pharmacological blockers enabled selective inhibition of particular channel types, thus eliminating the effect of NO.

5. To elucidate the mechanism of action induced by NO in modulating whole-cell current. NO is known to modulate ion channel function through direct oxidation/nitrosation of channel proteins. Alternatively, the NO-induced stimulation of soluble guanylate cyclase results in elevated levels of cytoplasmic cGMP and opens up a realm of second messenger interactions capable of regulating ion channel function.

Chapter III.

Experimental Procedures

A. Tissue Culture.

CFPAC-1 is an epithelial, pancreatic duct adenocarcinoma cell line, derived from a 26-year-old white male with CF ($\Delta F508$), pancreatic insufficiency (Schoumacher et al., 1990). PANC-1 is a corresponding human pancreatic carcinoma cell line, of the same ductal origin as CFPAC-1, but is derived from a non-CF patient (Madden and Sarras, 1988). Both these cell lines have been well characterized and used extensively in electrophysiological studies of cAMP-independent secretory processes, due to their lack of CFTR expression and highly developed Ca^{2+} -dependent secretory pathways (Warth and Greger, 1993). A549 is a type II pneumocyte cell line and has been characterized as a reliable model of alveolar epithelium. Considerable work has been done using this cell line in the evaluation of ion and drug transport (Mathias et al., 1996). In addition, these cells also lack the expression of CFTR at the membrane surface, and their whole-cell current response to NO has previously been documented, thus making them feasible for use as a positive control in some studies presented here (Kamosinska et al., 1997).

CFPAC-1, PANC-1 and A549 cell lines were obtained from the American Type Culture Collection (Rockville, MD). Cells were grown in Dulbecco's Modified Eagle Medium (DMEM; Sigma Chemical, St. Louis, MO) supplemented with 10% fetal bovine serum (HyClone Laboratories, Logan, UT), gentamycin sulfate (60 $\mu\text{g/ml}$), penicillin G (60 $\mu\text{g/ml}$) and streptomycin sulfate (100 $\mu\text{g/ml}$). The cells were maintained in a humidified incubator (95% air and 5% CO_2) at 37 °C.

Cells were subcultured by treatment with Trypsin-EDTA solution (0.05% (w/v) porcine trypsin, 0.02% (w/v) EDTA in Hanks balanced salt solution, Sigma). Any remaining trypsin residue was rinsed away by resuspending the cells in DMEM at a

density of approximately 1×10^5 cells per ml and centrifuging the cell suspension at $225 \times g$ for 5 min. The resulting cell pellet was resuspended in medium at the appropriate cell density, depending on the experimental procedure.

B. Measurement of Negative Surface Charge.

1. Cell Preparation.

Following treatment with trypsin, cells were resuspended in serum-containing media at a density of 1×10^6 cells per ml and incubated at 37°C , 5 % CO_2 for four hours with gentle shaking. This was sufficient time to allow the regeneration of surface molecules, which were digested during trypsin treatment. Mechanical separation of cells was not used, as cell viability was only 30 % after scraping with a rubber policeman. After four hours incubation the cells were washed twice in 10 ml of 0.25 M sucrose by centrifugation ($225 \times g$, 3 min) and resuspended in 0.25 M sucrose at a cell concentration of $2\text{--}4 \times 10^6$ cells per ml. Cell viability was normally above 95 per cent as estimated by exclusion of trypan blue.

2. Colloid Titration.

The technique of colloid titration was developed in the early 1950's (Terayama, 1952). It relies on a metachromatic shift in the absorption spectrum of toluidine blue (TB), a basic dye. A color change from blue to purple is visible when the dye binds to anionic groups. This method has been previously described in detail and used to calculate membrane negative charge on a variety of cell types (Van Damme et al., 1992; Van Damme et al., 1994).

An aliquot of 0.35 ml of the cell suspension described above was placed in a polystyrene, 0.5 ml semi-micro cuvette (Fisherbrand). Toluidine blue (20 μl of 0.1 % w/v) was then added to the cell suspension that appeared instantly purple as the dye bound to the negative charges on the cell surface. Cat-Floc, a standard polycation (polydiallyldimethylammonium chloride, $M_r = 8000$, Aldrich) was added using a micrometer syringe and the volume needed to displace the dye from its complex and obtain a visible color transition from purple to blue was noted. A total of twice this volume of Cat-Floc was added to ensure saturation of all negative sites in the suspension. A back-titration was then carried out by adding the standard polyanion, dextran sulfate (0.001 % w/v, $M_r = 40,000$, ICN Biochemicals) until the purple end-point was visible. The cell surface anionic charge content was calculated as follows:

- i) The mass of Cat-Floc displaced from the cell surface by dextran sulfate was calculated by subtracting the total mass of dextran sulfate from the total mass of Cat-Floc added. This is assuming that one molecule of Cat-Floc is displaced by one molecule of dextran sulfate.
- ii) The number of equivalent charges bound to the cell surface could then be calculated from the charge density of Cat-Floc (5.48 $\mu\text{eq}/\text{mg}$) as determined in a previous study using dextran sulfate (Van Damme et al., 1992).
- iii) By using Avogadro's number, the number of unit charges per cell was then calculated.

3. Determination of Sialic Acid Content on the Cell Surface.

3.1. Treatment with Neuraminidase.

Neuraminidase (from *Arthrobacter ureafaciens*, 0.15 units/ 10^7 cells in phosphate buffer, pH 6.5) was added to the cell suspension and incubated at 37 °C, 5% CO₂, for 3 hours with gentle shaking following the four hours recovery incubation period. After digestion with neuraminidase, the suspension was centrifuged at 1700 x g for 5 min, then washed and finally resuspended in 0.25 M sucrose. The supernatant was retained for chemical analysis to quantify the amount of sialic acid removed from the cell surface and aliquots of the cell suspension were taken for colloid titration measurements. Controls were carried out parallel to each enzyme digest where the cells were incubated in enzyme-free buffer.

3.2. Quantification of Sialic Acid Removed by Neuraminidase.

The thiobarbituric acid method described by Aminoff (Aminoff, 1961) was used to assess the amount of sialic acid removed from the cell surface by neuraminidase treatment. 0.5 ml of supernatant was incubated for 30 min at 37 °C with 0.25 ml periodate reagent (25 mM periodic acid in 0.125 N H₂SO₄, pH 1.2). The excess periodate was then reduced by adding 0.2 ml sodium arsenite (2 % sodium arsenite in 0.5 N HCl). When the yellow color from liberated I₂ had disappeared (1-2 min) 2 ml of thiobarbituric acid reagent was added (0.1 M 2-thiobarbituric acid in ddH₂O, pH 9.0 with NaOH). The samples were then covered and heated in a boiling water bath for 7.5 min, then cooled in ice-water and shaken with 5 ml acid butanol (butan-1-ol with 5 % (v/v) 12 N HCl). The absorbance of the butanol layer was measured at 549 nm. A standard curve was obtained

by using N-acetyl neuraminic acid from *Eschericia coli* (Boehringer Mannheim, Canada) at concentrations from 0.25-40 $\mu\text{g/ml}$ in phosphate buffer, pH 6.5.

C. Patch-clamp Technique.

Cells were separated from confluent monolayers by trypsinization and plated onto 35 mm culture dishes (Falcon, Franklin Lakes, NJ) at a density of $1-2 \times 10^4$ cells per ml. The cells were then incubated at 37 °C, 5% CO₂ for a minimum of four hours before being used for patch-clamp procedures. Whole-cell current measurements were obtained using perforated patch-clamp recordings. This technique has several advantages over conventional patch-clamp approaches. The main advantage being that the channels formed by amphotericin are impermeable to molecules larger than glucose, therefore electrophysiological recordings can be done without losing important substances from the cell cytoplasm. This is of particular relevance to these studies as physiological second messengers, such as cGMP are retained within the cell.

Pipettes were made from thin-walled borosilicate glass (A-M Systems Inc., Everett, WA) using a two-stage vertical puller (Nirashige, Japan). Pipette tips were fire-polished to a final resistance of 3-6 M Ω immediately before experiments. The pipette solution contained (in mM): 5 NaCl, 140 KCl, 0.5 MgCl₂, 1 CaCl₂, 10 N-2-hydroxyethylpiperazine-*N'*-2-ethanesulfonic acid (HEPES, pH 7.4) and 0.5 ethyleneglycol-bis(β -aminoethyl ether)-*N,N,N',N'*-tetraacetic acid (EGTA). Pipettes were filled as described previously (Rae et al., 1991) with the pipette solution containing 240 $\mu\text{g/ml}$ amphotericin B (Sigma Chemicals). This polyene antibiotic is capable of

partitioning the plasma membrane and forming ion channels that allow the movement of monovalent ions.

Cells were plated at least four hours prior to the experiment at a density of 6.25×10^4 cells/ml and rinsed three times in bath solution immediately before use. The bath solution contained (in mM): 140 NaCl, 5 KCl, 0.5 MgCl₂, 1 CaCl₂ and 10 HEPES (pH 7.4). In some experiments 140 mM NaCl was replaced with 140 mM choline chloride (Na⁺-free bath solution) to reduce Na⁺ movement across the cell membrane, thus allowing measurement of predominantly Cl⁻ current. Ca²⁺-free pipette and bath solutions were prepared as for normal solutions described above, using 5 mM EGTA in the pipette and 0.2 mM EGTA plus 3 mM sucrose in the bath solution.

Pipette offset potentials were compensated for prior to seal formation. Once a seal was formed, the conductance was monitored for 5-10 min. This time was sufficient for the perforation of the cell membrane by amphotericin B, as judged by the stabilization of the whole-cell current. Currents were recorded using an Axopatch 200A amplifier (Axon Instruments) and all currents were recorded within 5 min after the addition of reagents to be tested. All currents were reported in reference to zero in the bath. The recordings were acquired and analyzed using custom-written software. All experiments were done at room temperature. The mean whole-cell capacitance in these experiments was 4.84 ± 2.62 pF (n=69) and only cells with a series resistance of less than 20 M Ω were used for experiments. No leak subtraction was applied to observed currents. The current-voltage relationship was obtained from the mean current during the final 10 ms of the recording and the Levenberg-Marquardt algorithm (Press et al., 1990) was used to fit the current-voltage relationships with the Goldman-Hodgkin-Katz equation (Hille, 1992b)

$$I_i = \frac{P_i z_i^2 V_m F^2}{RT} \frac{C_b - C_p e^{-\frac{z_i V_m F}{RT}}}{1 - e^{-\frac{z_i V_m F}{RT}}}$$

where I_i , P_i and z_i denote the current, permeability and valency of the ion, i . C_b and C_p are the concentrations of ion, i , in the bath and pipette solution, respectively. R , T and F are the gas constant, temperature and Faraday constant, respectively.

D. Radioimmunoassay for cyclic-AMP and cyclic-GMP.

Cells were seeded in 24 well plates (Becton Dickinson Labware, NJ) at a density of approximately 65,000 cells per well and grown to confluence. Monolayers were washed three times with bath solution (as used for patch-clamp recordings) and then replaced with fresh bath solution containing 3-isobutyl-1-methylxanthine (IBMX; 100 μ M) or an equal volume of dimethylsulfoxide as a control and left for 5 min at room temperature. Cells were then treated with GSNO for 60 s after which the supernatant was replaced with acetic acid (300 μ l, 5 mM) and frozen on dry ice for 10 min. The cells were then lysed by boiling for 10 min in acetic acid and the supernatant was kept for radioimmunoassay detection of cGMP (Harper and Brooker, 1975). Standard curves were constructed with each set of samples using cGMP and cAMP from 0-2000 fmol. All samples were run in duplicate and radioimmunoassays for both nucleotides were run in parallel from the same cell preparation. The antibody used to bind cAMP/cGMP, recognizes the nucleotide better if it is acetylated, thus 10 μ l of triethylamine:acetic anhydride (2:1) was added to 10 μ l and 50 μ l of sample (for cAMP and cGMP assay, respectively). The mixture was vortexed immediately upon addition to the reaction tube. The quantitation of this immunoassay is based on competition for antibody binding sites

between a pool of radioisotope-labeled nucleotide and a non-radioactive nucleotide (in the sample). The acetylated samples and standards were then incubated overnight at 4 °C with rabbit anti-cAMP or -cGMP and ^{125}I -cAMP or ^{125}I -cGMP. Sheep anti-rabbit secondary antibody was added the next day and incubated for at least 1 hour at 4 °C. Polyethylene glycol (7.5 %) was then added and the antibody complex was precipitated by centrifugation at 2,000 x g at 4 °C for 45 min. The supernatant was then decanted and the samples were counted using a Packard Cobra Auto-gamma counter.

E. Detection of Soluble Guanylate Cyclase by Western Blot Analysis.

The detection of soluble guanylate cyclase protein was done using a polyclonal antibody, raised against synthetic peptides from the α_1 and β_1 subunits of the enzyme (Alexis Biochemicals, San Diego, CA). CFPAC-1 and PANC-1 cells were grown to confluence in 25 cm² tissue culture flasks. All subsequent procedures were carried out on ice. The monolayers were rinsed in serum free medium three times before adding 0.5 ml ice-cold homogenization buffer per flask (Tris-HCl, pH 7.4 (50 mM) containing leupeptin (10 $\mu\text{g}/\text{ml}$) pepstatin (10 $\mu\text{g}/\text{ml}$), aprotinin (25 $\mu\text{g}/\text{ml}$) and 0.1 % Triton X-100). After scraping, the cell suspension was sonicated and the membrane fraction pelleted by centrifugation (16,000 x g, 4 °C). The clear supernatant was collected and the protein concentration was measured by using the BioRad protein assay kit (Bio-Rad Laboratories, Hercules, CA). Bovine serum albumin was used as a standard.

Protein preparations and standard marker proteins were solubilized in Laemmli buffer and electrophoresed in a 7 % sodium dodecyl polyacrylamide gel. Separated protein

bands were then transferred electrophoretically (1 A, 90 min at 4 °C) to a polyvinylidene difluoride (PVDF) membrane (Bio-Rad) in Towbin buffer containing 20 % methanol. Membranes were then incubated, overnight in blocking buffer containing Tris-HCl (10 mM), NaCl (0.1 mM), Tween 20 (0.1 % v/v) and nonfat dry milk (5 % w/v). After this, membranes were then probed with polyclonal antibodies against soluble guanylate cyclase (1:2000 dilution of commercial antibody preparation in blocking buffer) for 2 hours. The excess primary antibody wash then rinsed off by washing for 5 x 5 min in blocking buffer and the detection of protein bands was carried out by using a goat anti-rabbit IgG peroxidase conjugate as a secondary antibody (Sigma, 1:5000 dilution of commercial preparation in blocking buffer) for 1 hour. Following this, the membrane was rinsed as before (5 x 5 min) and an enhanced chemiluminescence (ECL) detection kit (Amersham, Oakville, ON) was used to identify protein bands.

F. Measurement of Nitric Oxide Synthase Activity (L-citrulline assay).

Cell homogenate was prepared by scraping confluent monolayers into homogenization buffer, containing 50 mM Tris HCl/Base, 320 mM sucrose, 1 mM dithiothreitol, 10 µg/ml soya bean trypsin inhibitor, 10 µg/ml leupeptin, 2 µg/ml aprotinin and 0.1 % triton X-100, as described previously (McKendrick et al., 1998). The samples were frozen immediately on dry ice then sonicated prior to the assay. 5-15 mg/ml of homogenate protein was incubated in assay buffer. Assay buffer contained in mM: 50 KH₂PO₄, 1 MgCl₂, 0.2 CaCl₂, 50 L-valine, 1 L-citrulline, 0.02 L-arginine, 1.5 dithiothreitol, 0.01 tetrahydrobiopterin, 1.3 flavin adenine dinucleotide, 3.8 flavin

mononucleotide and 3.4 β nicotinamide dinucleotide phosphate. In addition, the assay buffer also contained 100 μ l of L[U- 14 C]-arginine (Amersham Life Sciences, Inc.) per 10 ml of buffer. After 20 min incubation at 37 $^{\circ}$ C the reaction was stopped by addition of 1 ml Dowex 50WX8-400 ion exchange resin (200-400 dry mesh, Sigma). The resin was left to sediment for at least 45 min after which 400 μ l of supernatant was removed and 14 C-bound radioactivity was measured by scintillation counting.

G. Glutathione Assay.

Cells were grown to confluence and rinsed twice with serum-free medium. The monolayers were then incubated for 1 hour in fresh serum-free medium, with or without GSNO (100 μ M) at 37 $^{\circ}$ C, 5 % CO₂. Incubation medium was then removed and monolayers were rinsed twice in ice-cold PBS. Cells were harvested on ice by scraping into 5 % metaphosphoric acid containing 10 μ g/ml soya bean trypsin inhibitor, 10 μ g/ml leupeptin and 2 μ g/ml aprotinin. The samples were then sonicated and protein content was measured, as mentioned previously. The cell homogenates were then centrifuged at 3,000 x g at 4 $^{\circ}$ C for 10 min and 300 μ l of supernatant was taken for glutathione measurement using a colorimetric glutathione assay kit (Calbiochem, San Diego, CA). A standard curve was constructed using reduced glutathione in 5 % metaphosphoric acid at 0-400 μ M.

H. Statistical Analysis.

Data are expressed as means \pm SD, using Origin Technical Graphics and statistical differences between groups were determined using a two-tailed Student's t-test or

analysis of variance (ANOVA) for paired variates and multiple variates respectively. $P < 0.05$ was considered significant (InStat, GraphPad software Inc., USA) was used for this analysis.

Chapter IV.

Results

A. Decreased Negative Charge on the Surface of Cystic Fibrosis Epithelial Cells[†]

1. Recovery of Surface Charge after Trypsinization

The dissociation of cell monolayers to create cell suspensions, was done by treatment with trypsin (see 'Experimental Procedures'). Removing cells from the plates by scraping was unsatisfactory, because the cell viability after this was less than 30 %. In addition, fragments of broken cell membrane and cytosolic contents significantly increased the surface charge values. Therefore, cells were detached from the culture flasks by treatment with trypsin. Trypsin has been shown to reduce cytoadhesion by cleaving portions of the glycocalyx and this removal of heavily glycosylated proteins has been shown to affect negative surface charge (Nagao et al., 1995). It was therefore necessary to examine the effect of trypsin treatment on the surface charge of pancreatic ductal epithelial cells. It was found that if the cells were incubated in culture medium and shaken gently for 4 hours to prevent cell adherence, the surface charge was recovered (figure 10). This observation is in agreement with previous studies by Slater and Sloan (Slater and Sloan, 1975) who found that 3-6 hours was sufficient for the recovery of endothelial cells after trypsinization. All further investigations involving surface charge were done with cells that were allowed to recover in culture medium for 4 hours after trypsinization.

[†] A version of this section has been published. Thethi, K. and Duszyk, M. (1998) Decreased Cell Surface Charge in Cystic Fibrosis Epithelia. *Cell Biochemistry and Function*. 15:35-38.

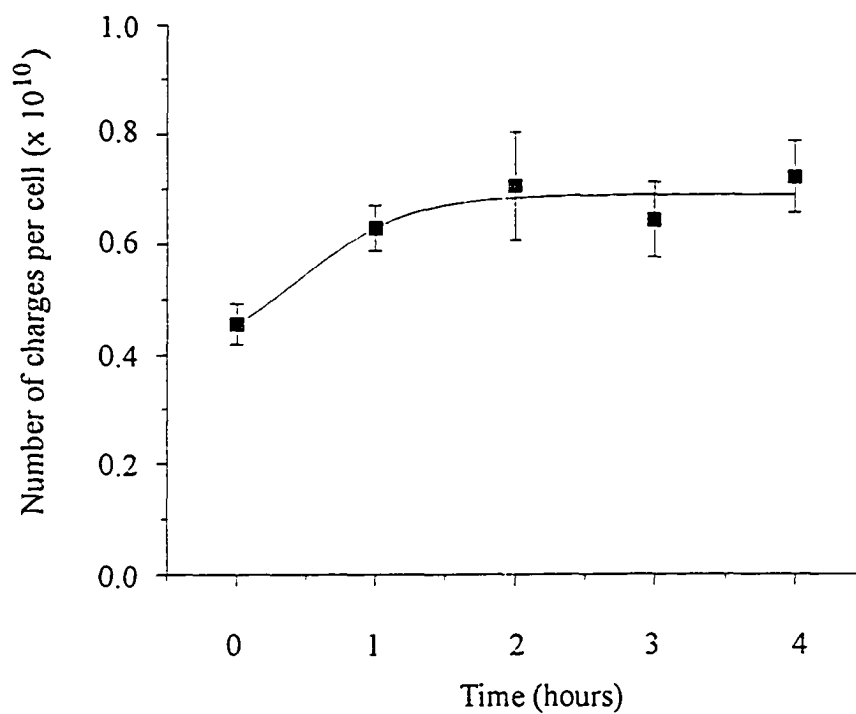

Figure 10. Recovery of negative surface charge after treatment with trypsin. The results are presented as mean \pm standard deviation of five different experiments.

2. The Effect of Cell Generation on Surface Charge

In contrast to primary cultures, cell lines can be maintained in culture for an extended period of time without severe alterations in phenotype (Hopfer et al., 1996). Sialic acid is a major contributor to negative surface charge and it has previously been shown that loss of sialic acid residues occurs during continual passaging and cell aging, and thus results in the depletion of negative surface charge (Dhermy et al., 1987; Wen et al., 1998; Yamamoto and Yamamoto, 1991). Here, I examined the effect of continual passaging of CFPAC-1 cells and PANC-1 cells on surface charge properties by performing colloid titration procedures on cells of different generations. Figure 11 shows that after 40-50 passages of the original commercial stock of cells, negative surface charge in both cell lines falls to approximately half that observed in the first 11-13 passages. A significant difference in the number of charges per cell was observed between the two cell lines and this difference remained throughout passages 11-13, 20-22 and 40-50. Two-tailed student's *t*-test indicated that the differences in surface charge between cell lines were statistically significant at $P < 0.0001$, in each of the three passage number groups shown in figure 11. All subsequent experiments were carried out using cells of 11-13 passages after plating of the original commercial stock.

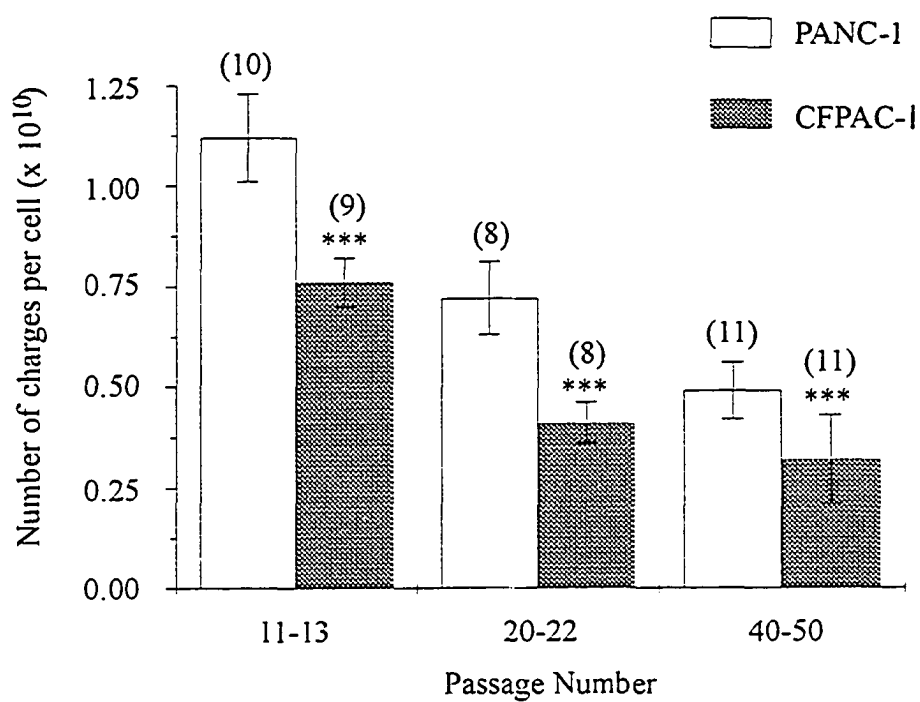

Figure 11. The effect of cell generation on negative surface charge. Passage number represents the number of passages after plating the commercially obtained, frozen cultures. The data are presented as mean \pm standard deviation and the number of experiments is shown in parentheses. The number of charges per cell observed in CFPAC-1 cells is significantly lower than that observed in PANC-1 cells, *** $P < 0.0001$.

3. Decreased Cell Surface Charge in Cystic Fibrosis Epithelia

Acidic and basic amino acids at the cell surface exhibit positive or negative electrostatic charges at physiological pH and further surface electrostatic charges are present in the form of carbohydrates and lipids. Polysialic acid is one of the major contributors to negative surface charge on many cell types and the removal of such residues has been shown to affect channel function (Hille et al., 1975). Here, I have characterized a difference in the negative surface charge of CF cells as compared to that of non-CF cells. The surface charge of CFPAC-1 cells was found to be approximately 68 per cent of that found on PANC-1 cells (figure 12). In order to characterize the contribution of *N*-acetyl neuraminic acid residues to the negative surface charge, cells were treated with neuraminidase (0.15 units per 10^7 cells). This enzyme specifically cleaves sialic acid residues, which are α 2,3-, α 2,6- or α 2,8-linked to oligosaccharides, glycoproteins or glycolipids. Treatment with neuraminidase significantly reduced the surface charge content of both PANC-1 cells and CFPAC-1 cells by removing sialic acid residues, but the difference in charges per cell between the two cell lines remained statistically significant, $P < 0.0001$ (figure 12). Furthermore, no significant difference was found between the amount of sialic acid released from PANC-1 and CFPAC-1 cells by treatment with neuraminidase (figure 13).

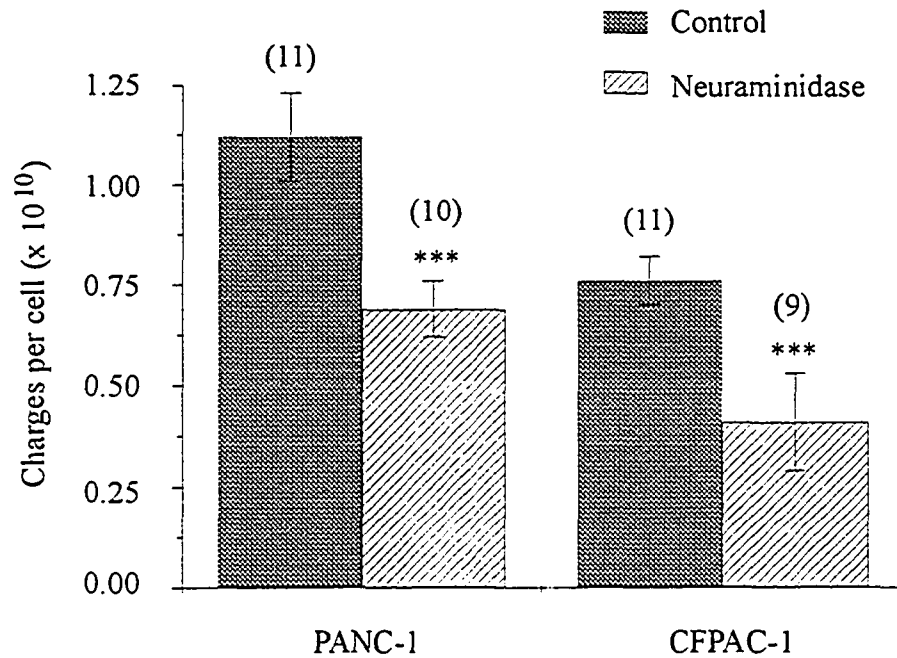

Figure 12. The surface charge of PANC-1 and CFPAC-1 cells, with and without neuraminidase treatment. A two-tailed student's t-test showed that CFPAC-1 cells exhibit a significantly lower number of negative charges per cell than PANC-1 cells ($P < 0.0001$). The removal of sialic acid residues by treatment with neuraminidase (0.15 units per 10^7 cells, in phosphate buffer, pH 6.5 for 3 hours at 37°C) caused a significant decrease in surface charge as compared to control levels in both cell lines (*** $P < 0.0001$). PANC-1 cells still retained a significantly higher surface charge content even after neuraminidase treatment ($P < 0.0001$). Data are shown as mean \pm standard deviation and the number of experiments is shown in parentheses.

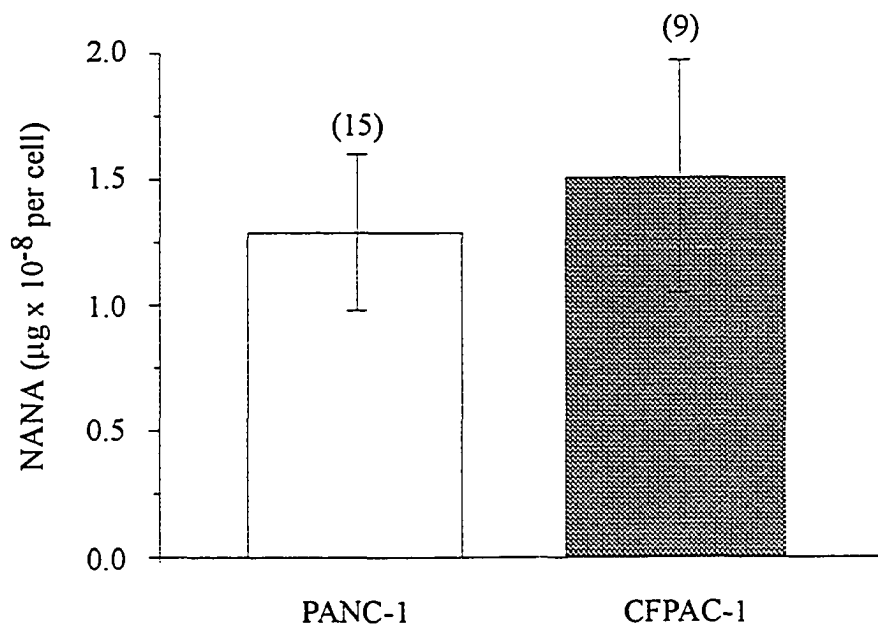

Figure 13. Determination of sialic acid content on the cell surface. Quantitative analysis of *N*-acetyl neuraminic acid (NANA), removed from PANC-1 cells and CFPAC-1 cells by neuraminidase, was done by using the thiobarbituric acid method. Data are represented as mean \pm standard deviation and the number of experiments is shown in parentheses. No statistically significant difference lies between NANA content of PANC-1 cells and that of CFPAC-1 cells.

B. Characterization of Nitric Oxide Action on Ion Channels in CF Pancreatic Epithelia^{††}

1. *The Effect of Nitric Oxide Donors on Whole-Cell Current in CF and Non-CF Epithelial Cells.*

The redox status in CF tissues has shown to be unbalanced with an altered antioxidant status, combined with aberrant free radical activity and elevated levels of NO due to an inflammatory state (Portal et al., 1995). NO has been shown to regulate channel function in many cell types by chemical alteration of surface molecules and by the activation of cGMP-dependent pathways and this may be important in CF pathophysiology. Here, I have addressed the question: does NO affect channel function in CF pancreatic ductal epithelia?

Figure 14 shows typical recordings of basal whole-cell current in PANC-1 and CFPAC-1 cells, obtained under nonsymmetrical cationic solutions (pipette 140 mM KCl, bath 140 mM NaCl). The addition of GSNO (100 μ M) to the bath solution significantly reduced the basal current in CFPAC-1 cells ($P < 0.01$) but had no effect on whole-cell current in PANC-1 cells. Similar results were obtained with another NO donor, SNAP (figure 15). There was no further decrease in whole-cell current when GSNO was added to the bath solution, demonstrating that the effect was due to NO and not the donor molecule.

^{††} A version of this section is currently in press. Thellu, K. and Duszyk, M. (1999) Nitric Oxide Inhibits Whole-Cell Current in Cystic Fibrosis Pancreatic Epithelial Cells. *Pancreas*. In press.

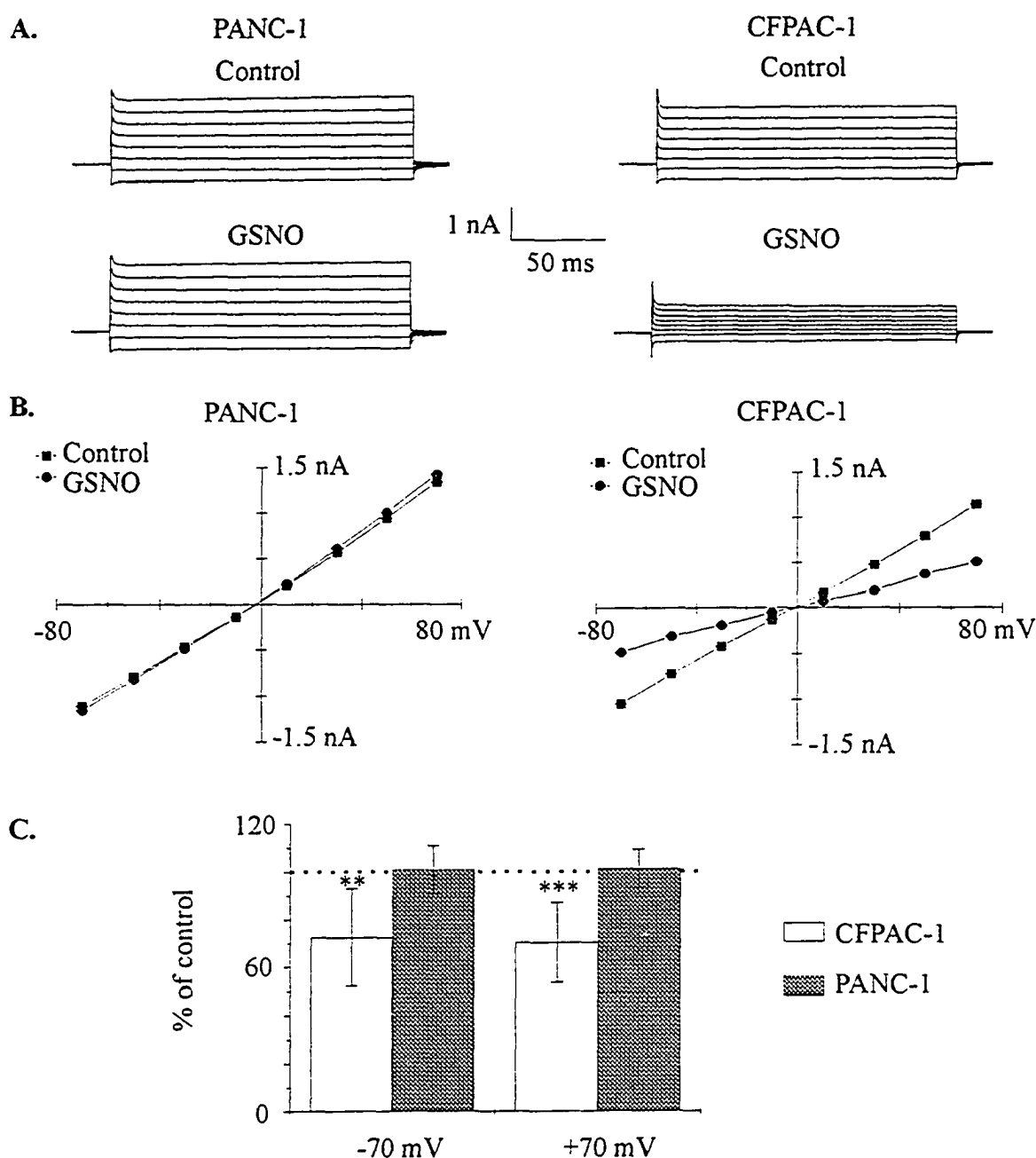

Figure 14. The effect of GSNO on whole-cell current in PANC-1 and CFPAC-1 cells. **(A)** Representative recordings showing the effect of GSNO (100 μ M) on basal whole-cell current in PANC-1 and CFPAC-1 cells. **(B)** Current-voltage relationships corresponding to recordings in panel A. Data are typical of recordings from 8 individual cells for both cell lines. **(C)** Histogram summarizing effect of GSNO at ± 70 mV ($n=8$ in all cases). Dotted line represents control level (100%). ** $P < 0.01$, *** $P < 0.001$.

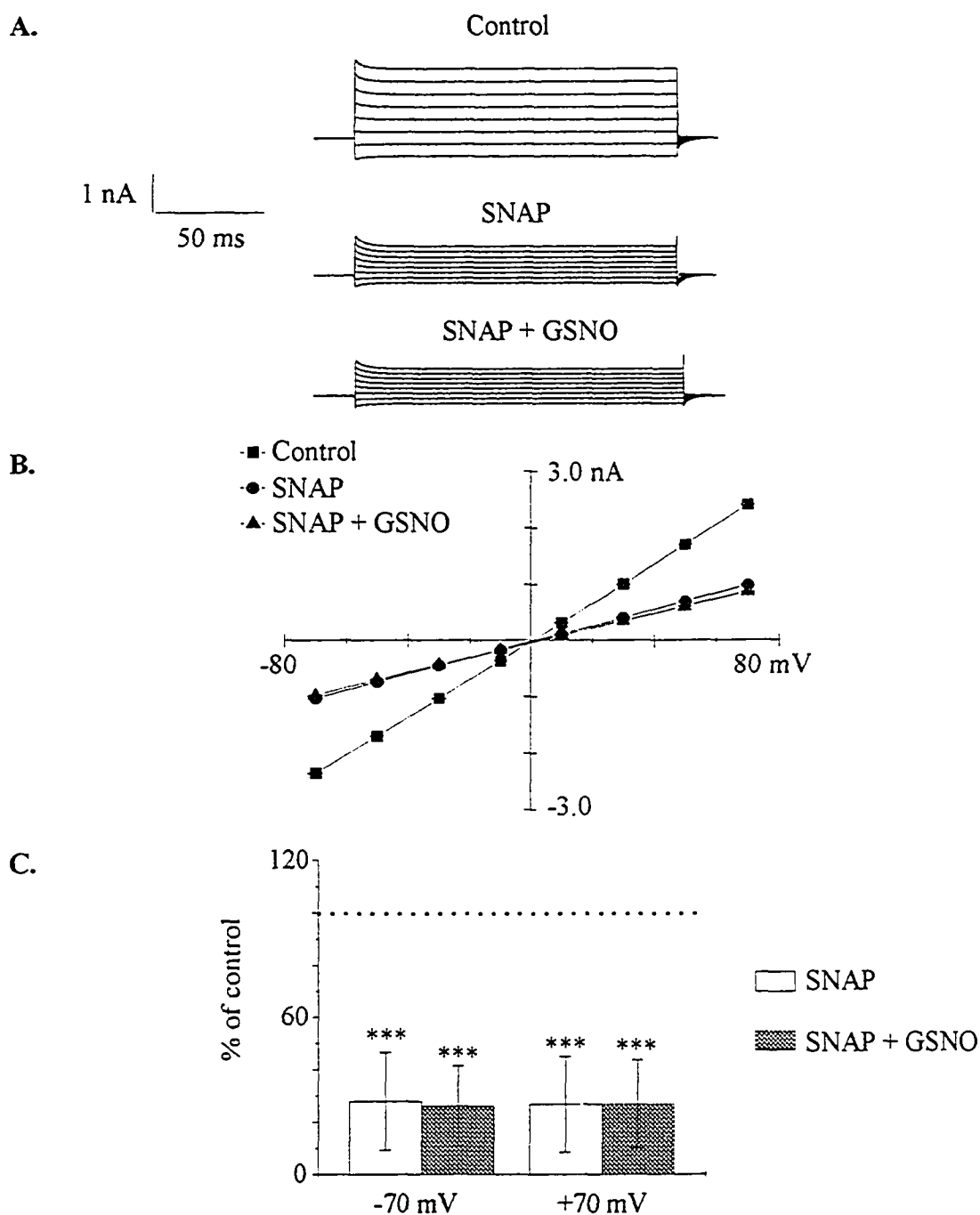

Figure 15. The effect of SNAP on whole-cell current in CFPAC-1 cells. **(A)** Typical recordings showing the effect of SNAP (100 μ M) and subsequent addition of GSNO (100 μ M). **(B)** Current-voltage relationships corresponding to recordings shown in panel A. The data are representative of experiments from 4 different cells. **(C)** Histogram summarizing data at ± 70 mV from all experiments (dotted line represents control at 100 %, $n=4$ in all cases). SNAP significantly decreased whole-cell current (***) $P < 0.001$ compared with control values at ± 70 mV). No significant difference lies between SNAP and subsequent GSNO treatment ($P > 0.05$).

2. Involvement of Constitutively Produced NO in Modulating Whole-cell Current in CF Pancreatic Epithelia.

Although NO concentration has not been directly measured in the pancreas, it has been shown that NOS in a variety of cell types produces micromolar concentrations of NO (Ischiropoulos et al., 1992; Malinski et al., 1993; Tschudi et al., 1996). It must be considered that amounts of NO used in my studies are similar to those found in pancreatic tissues, under inflammatory conditions (Scheele et al., 1996). This assumption is based upon the fact that the NO-donor SNAP (100 μM) generates a stable NO concentration of 0.1 μM at 25 °C (Ichimori et al., 1994) and that this is similar to concentrations found in other cell types (Ischiropoulos et al., 1992; Malinski et al., 1993; Tschudi et al., 1996). In addition, iNOS activity in the pancreas is elevated during inflammation (Al-Mufti et al., 1998). In order to investigate if the NO-induced effects on whole-cell current are of importance only under pathophysiological conditions, or whether NO also participates in regulating whole-cell current under normal physiological conditions. I have firstly used a direct method of measuring constitutive NOS activity, hence giving an indication of NO production under physiological conditions and secondly, I have used nitro-L-arginine-methyl ester (L-NAME) to inhibit constitutive production of NO in CFPAC-1 cells.

L-citrulline is a by-product from the catalytic activity of NOS isoforms, thus by measuring levels of L-citrulline within the cell, in the presence or absence of Ca^{2+} , or pharmacological NOS inhibitors, one can assess the activity of specific NOS isoforms and hence NO production. Figure 16 shows that no measurable activity of inducible NOS is seen in the absence of cytokine stimulation. Constitutive NOS activity in CFPAC-1

cells is significantly higher than that in PANC-1 cells ($P < 0.05$, $n = 3$). The human lung epithelial cell line, A549, treated with 1 ng/ml interleukin- 1β , 1 ng/ml tumor necrosis factor- α and 10 ng/ml interferon- γ for 8 hours was used as a positive control for expression of constitutive and inducible NOS isoforms. This observation indicates that constitutively produced NO may be altered by the CF phenotype.

L-NAME is a widely used inhibitor of constitutive NOS isoforms. This inactive prodrug undergoes enzymatic or non-enzymatic cleavage to produce N^G -nitro-L-arginine (L-NNA). This analogue of L-arginine binds to the substrate site of NOS with a 10-fold higher affinity than L-arginine and triggers rapid enzyme inactivation that is accompanied by complete blockade of NADPH-dependent heme reduction (Mayer and Andrew, 1998). Consequently, NO production is inhibited, as is O_2^- production. Inhibition of NOS activity with L-NAME (1 mM) had no apparent effect on whole-cell current (figure 17) suggesting that constitutively produced NO does not affect basal whole-cell current ($P > 0.05$, $n = 4$) and that the observed NO-induced inhibition of whole-cell current in CFPAC-1 is relevant to pathological conditions.

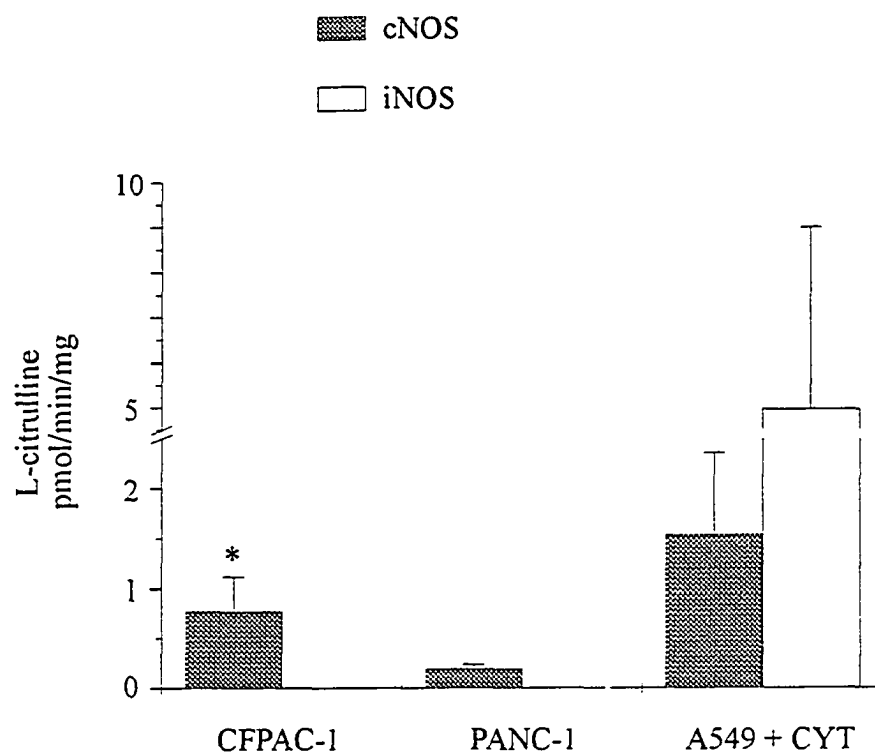

Figure 16. Constitutive NO levels are elevated in CFPAC-1 cells. Histogram showing activity of NOS isoforms in CFPAC-1 and PANC-1 cells. A549 treated with cytokines was used as a positive control. * $P < 0.05$ compared to PANC-1 (two-tailed student's t-test; $n=3$ in all cases).

3. Identification of Channel Types Affected by Nitric Oxide in CF Pancreatic Epithelial Cells.

To determine which channel types are affected by the inhibitory action of GSNO, a range of channel blockers were applied to the bath solution prior to the addition of GSNO. In this section I have evaluated the contribution of four different channel types, known to be involved in regulating secretory processes in pancreatic epithelial cells. These channel types, are rate-limiting to HCO_3^- secretion in pancreatic duct epithelia and have been described in Chapter I.

It has been shown previously that GSNO and other NO donors applied to alveolar type II cells inhibit amiloride-sensitive Na^+ channels (Guo et al., 1998; Jain et al., 1998), thus it is of importance to investigate if this channel type is being targeted by NO in CFPAC-1 cells. The presence of a non-selective cation channel in rat pancreatic duct cells has been noted (Gray and Argent, 1990a) and these channel types display variable sensitivity to amiloride (see Chapter I). To assess the involvement of such channel types in CFPAC-1 cells we applied amiloride (50 μM) to Na^+ -containing or Na^+ -free bath solution. Experiments using both Na^+ -containing and Na^+ -free bath solutions gave similar results, thus data was pooled to give an overall evaluation of amiloride on the effect of GSNO (figure 18). A significant inhibitory effect on the basal whole-cell current was observed, reducing it to $80.64 \pm 9.33 \%$ ($P < 0.01$) and $89.38 \pm 9.83 \%$ ($P < 0.05$) at -70 mV and $+70 \text{ mV}$, respectively ($n=9$). That amiloride had a significant inhibitory effect on basal whole-cell current in Na^+ -free bath solution, strongly suggests that the channels being inhibited by amiloride are non-selective cation channels as oppose to amiloride-sensitive, Na^+ -selective channels. Indeed, the mathematical model of pancreatic duct

epithelium described by Sohma et al. predicts this to be the case (Sohma et al., 1996). The results indicate a significant contribution of ion flux through this channel type to maintain the basal state. The subsequent application of GSNO (100 μ M) in the presence of amiloride caused an additive decrease in whole-cell current to 70.12 ± 12.81 % and 75.71 ± 9.02 % at -70 mV and +70 mV, respectively. Significance levels were $P < 0.01$, compared to control level and $P < 0.01$, compared to amiloride-inhibited current at ± 70 mV (n=9). This demonstrates that amiloride-sensitive channels are probably not involved in the inhibitory effect of GSNO.

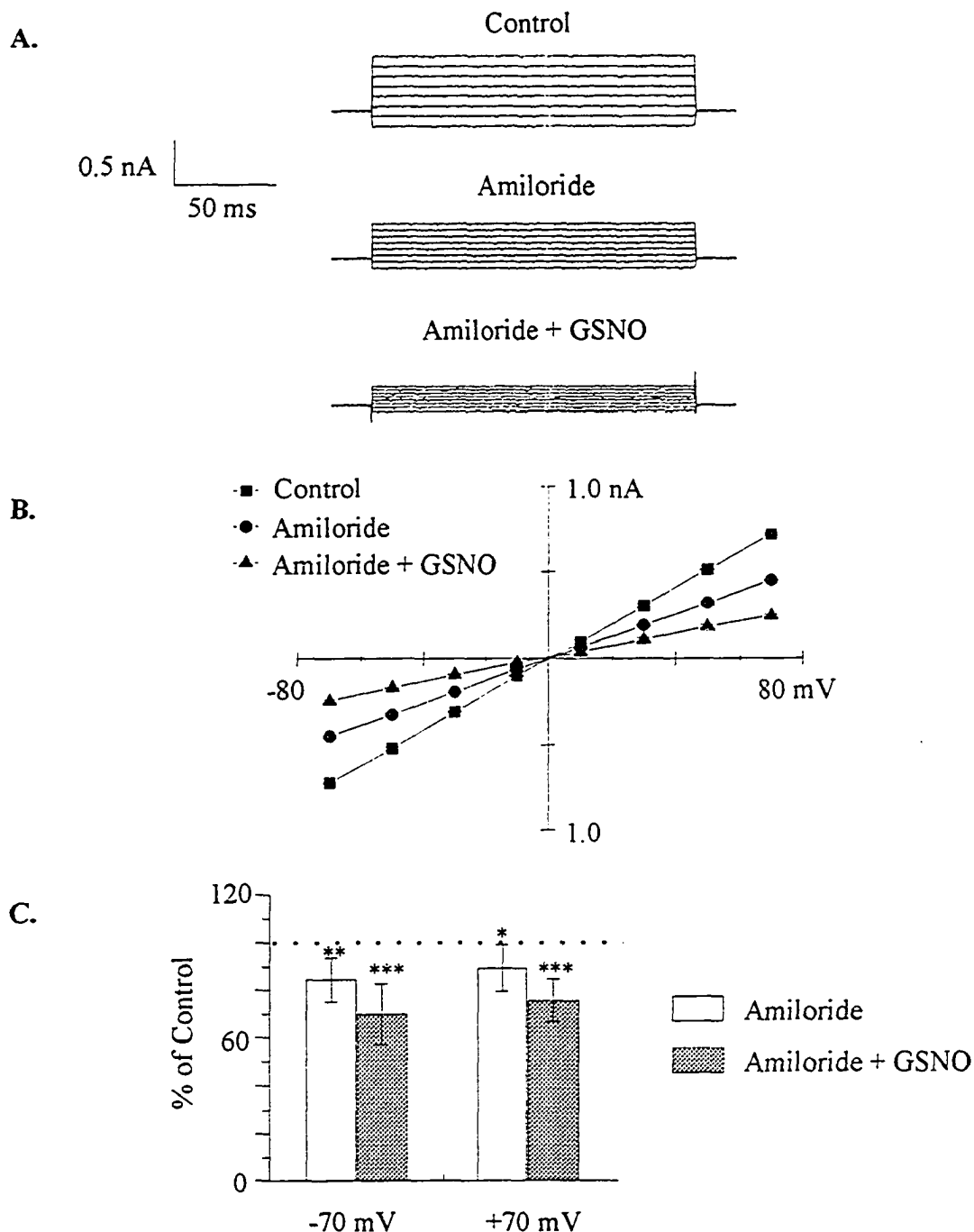

Figure 18. Amiloride does not block the effect of GSNO in CFPAC-1 cells. **(A)** Representative recordings showing the additive effect of amiloride (50 μ M) and subsequent addition of GSNO (100 μ M) on basal whole-cell current. **(B)** Current-voltage relationships corresponding to recordings shown in panel A. **(C)** Histogram summarizing data at ± 70 mV from all experiments ($n=9$; dotted line represents control at 100%; * $P<0.05$, ** $P<0.01$, *** $P<0.001$ compared with control values at ± 70 mV). GSNO causes a significant additive decrease in whole-cell current in the presence of amiloride ($P<0.01$, amiloride treatment compared to amiloride + GSNO treatment at ± 70 mV).

L-cis-diltiazem is known to selectively block cGMP-gated, non-selective cation channels, whereas amiloride-sensitivity varies (Bucossi et al., 1997). As NO may act via a cGMP-dependent pathway, this channel blocker was applied to the bath solution (normal, Na⁺-containing bath solution) to determine, more specifically, the role of these channel types in the GSNO-induced inhibition of whole-cell current. CNG channels are activated by an elevation in cGMP, thus if the effect of GSNO was targeted to these channels, an increase in whole-cell current would be expected. As predicted, there was no significant decrease ($P > 0.05$, $n=5$) in whole-cell current seen when diltiazem (100 μ M) was added to the bath solution (figure 19). This indicates that these channel types may not be present in CFPAC-1 cells, or at least that they are not crucial in maintaining the basal secretory state. This channel blocker also did not block the effect of GSNO. Figure 19(C) summarizes the effect of the NO donor, in the presence of diltiazem. Whole-cell current was reduced to 67.27 ± 12.64 % and 65.97 ± 11.87 % of the control level at -70 mV and +70 mV respectively ($P < 0.01$, compared to control, $n=4$).

Ca^{2+} -activated potassium channels have been characterized in pancreatic duct epithelia (Roch et al., 1995; Nguyen et al., 1998b; Nguyen and Moody, 1998a; Gray et al., 1990b) and CFPAC-1 cells (Galiotta et al., 1997). This basolateral conductance is capable of hyperpolarizing the cell, thus providing the electrical driving force for HCO_3^- (and Cl^-) secretion at the apical membrane. Charybdotoxin is a protein present in the venom of the scorpion *Leiurus quinquestriatus var. hebraeusis* and is a specific blocker of Ca^{2+} -activated K^+ channels (Gimenez-Gallego et al., 1988). The application of charybdotoxin (100 nM) to the bath solution (figure 20) reduced the whole-cell current to $76.68 \pm 15.22 \%$ and $78.72 \pm 10.58 \%$ of the control level at -70 mV and $+70 \text{ mV}$ respectively ($P < 0.01$, $n=7$) indicating a strong contribution of this channel type to the basal current. No significant decrease was seen in basal whole-cell current upon subsequent addition of GSNO in the presence of charybdotoxin ($P > 0.05$, compared to charybdotoxin-inhibited current, $n=5$).

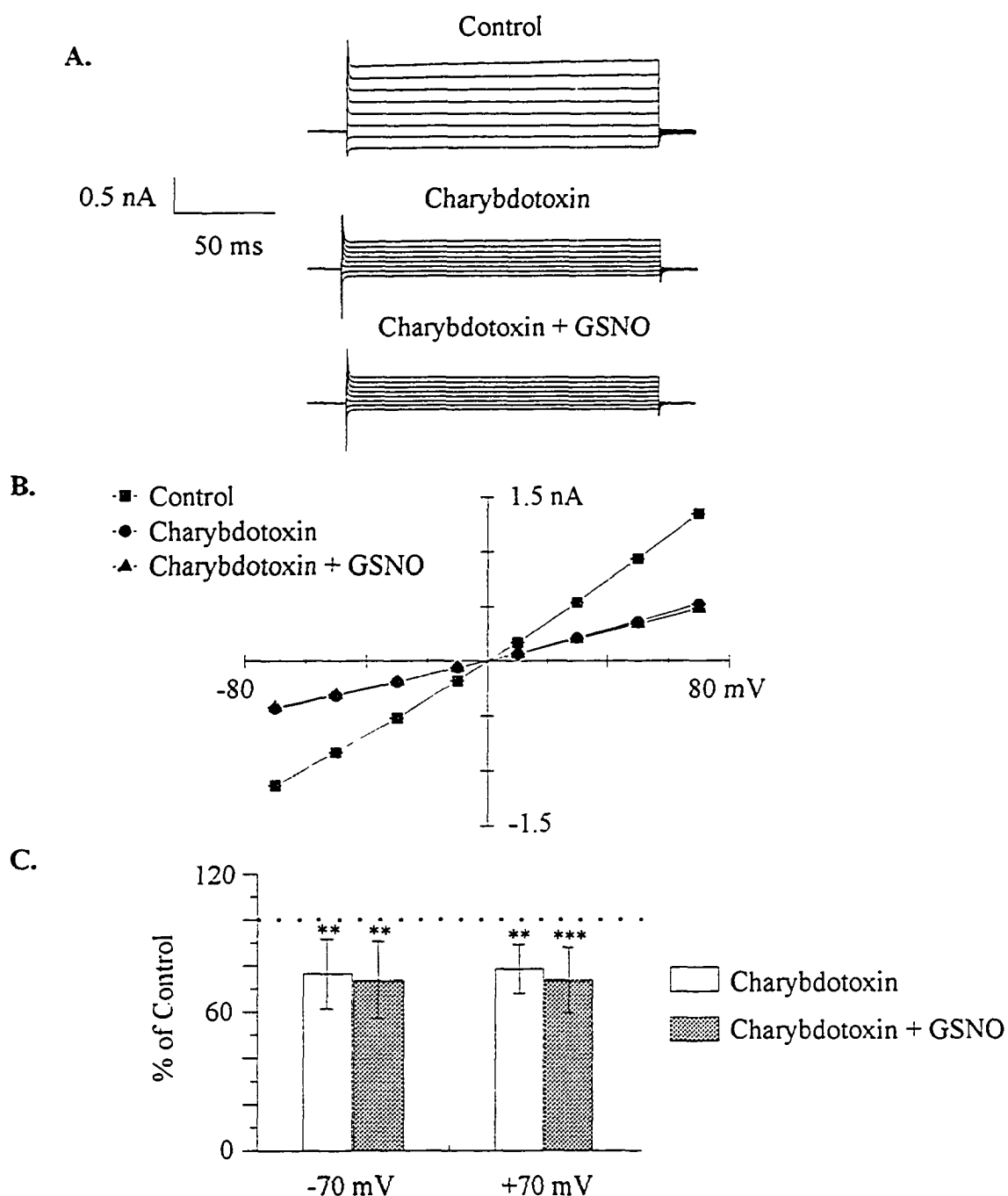

Figure 20. Charybdotoxin blocks the effect of GSNO in CFPAC-1 cells. **(A)** Representative recordings showing the inhibition of basal whole-cell current by charybdotoxin. No additive effect of GSNO (100 μ M) is seen in the presence of charybdotoxin (100 nM). **(B)** Current-voltage relationships corresponding to recordings shown in panel A. **(C)** Histogram summarizing the inhibition of basal whole-cell current at 70 mV by charybdotoxin ($n=7$) and GSNO ($n=5$). Dotted line represents control level at 100%, ** $P<0.01$, *** $P<0.001$.

Ca^{2+} -activated Cl^- channels are targeted as alternative Cl^- secretory pathways in the apical membrane of CF epithelia. Particular focus has been on the activity of this channel type in CF mouse models, where the CF defect is circumvented in some tissue types due to the highly developed Ca^{2+} -dependent secretory pathway (Snouwaert et al., 1992). Several groups have noted CACC as being a significant contributor to Cl^- secretory pathways in pancreatic duct epithelia (Eguiguren et al., 1996; Al-Nakkash and Cotton, 1997; Schoumacher et al., 1990; Warth and Greger, 1993).

To investigate the contribution of CACC in maintaining basal whole-cell current in CFPAC-1 cells, DIDS (20 μM) was added to the bath solution (figure 21). Basal whole-cell current was inhibited by DIDS to $83.31 \pm 14.12 \%$ and $83.84 \pm 13.22 \%$ of the control level at +70 mV and -70 mV, respectively ($P < 0.05$, compared to control; $n=8$; see figure 21C). The additive effect of GSNO (100 μM) with DIDS appeared to be small, and no significant difference was found when compared to treatment with DIDS alone by using ANOVA ($P > 0.05$; $n=8$). This shows that DIDS blocks the inhibitory effect of GSNO on whole-cell current and suggests that Ca^{2+} -activated Cl^- channels are also targeted by NO.

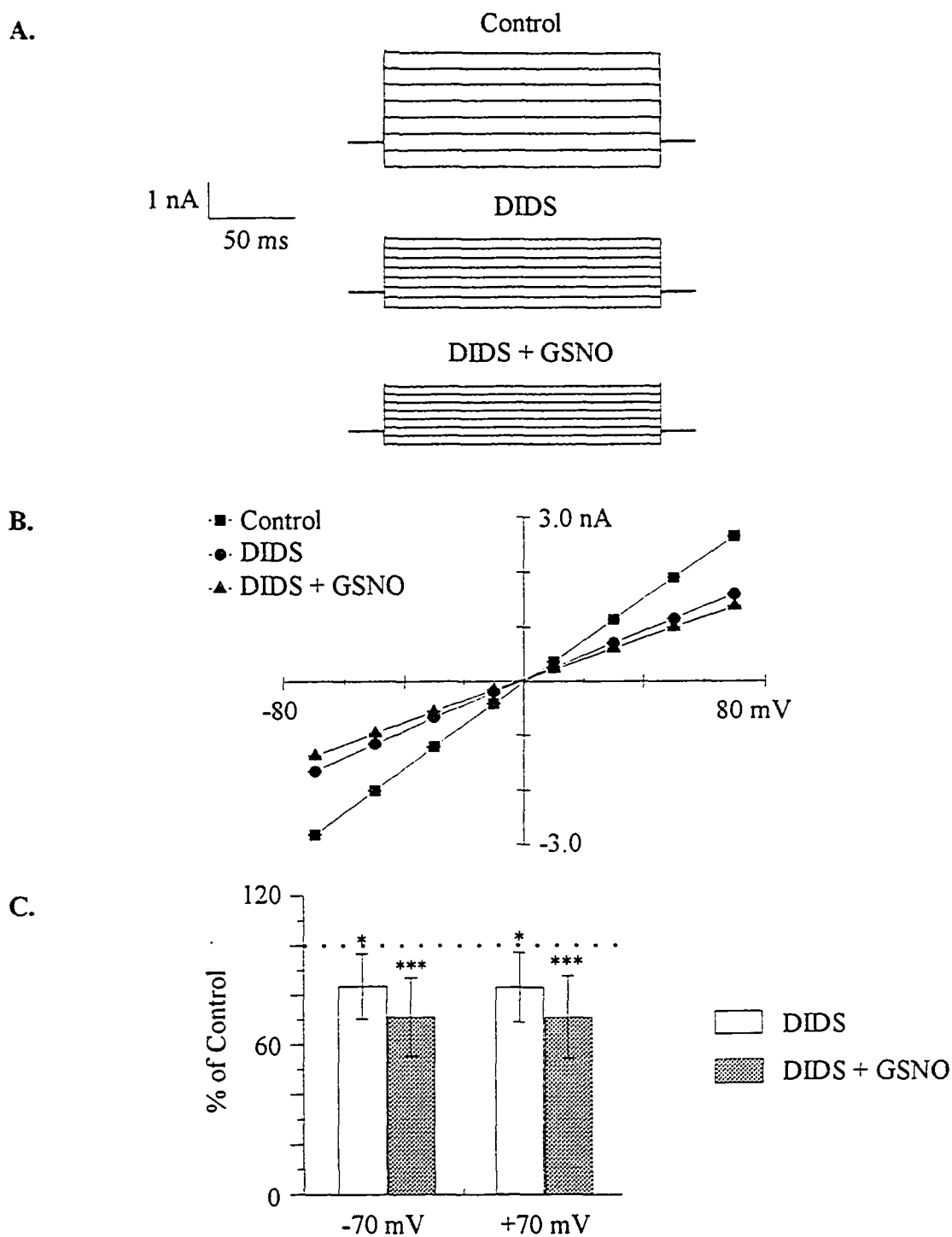

Figure 21. DIDS decreases the effect of GSNO on whole-cell current in CFPAC-1 cells. (A) Representative recordings showing the inhibition of basal whole-cell current by DIDS (20 μ M) and GSNO (100 μ M). (B) Current-voltage relationships corresponding to recordings shown in panel A. (C) Histogram summarizing the contribution of DIDS-sensitive Cl⁻ channels to basal whole-cell current and the effect of GSNO (n=8 in all cases). Dotted line represents control level at 100%. * P <0.05, *** P <0.001.

4. A Role for Calcium in GSNO-induced Inhibition of Whole-cell Current

In epithelial cells a major role for intracellular Ca^{2+} is the regulation of ion channel function. In CF epithelia, where cAMP-dependent Cl^- secretion is dysfunctional, Ca^{2+} -activated pathways play a crucial role in maintaining transepithelial ion transport (Boucher et al., 1989). CFPAC-1 cells lack cAMP-activated secretory pathways (CFTR) and therefore provide a good model for investigating alternative secretory mechanisms in CF epithelia. In the exocrine pancreas, regulation of fluid secretion by ATP, acetylcholine and cholecystinin is mediated by an elevation in intracellular Ca^{2+} , which then activates basolateral K^+ channels and apical Cl^- channels (Martin and Shuttleworth, 1996; Ashton et al., 1993). Nitric oxide is capable of decreasing cytoplasmic Ca^{2+} by regulating release/uptake from intracellular stores or by regulating Ca^{2+} influx at the cell membrane (Clementi and Meldolesi, 1997). Thus, if cytoplasmic Ca^{2+} is involved in the NO-induced inhibition of whole-cell current, depletion of Ca^{2+} from the cell should attenuate the effect of NO. Such an approach has been applied to isolated segments of rat ileum, whereby depleting intracellular Ca^{2+} stores attenuated the effect of NO donors and 8-Br-cGMP on smooth muscle relaxation (Franck et al., 1998). Charybdotoxin-sensitive K^+ channels and DIDS-sensitive Cl^- channels are both Ca^{2+} -dependent. Thus, it is possible that channel inhibition may be due to a NO-induced change in cytoplasmic Ca^{2+} levels. To investigate this hypothesis Ca^{2+} -free bath and pipette solutions were used. Figure 22 (A and B) shows that by removing Ca^{2+} from the bath and pipette solutions, the inhibitory effect of GSNO on whole-cell current is eliminated. Figure 22C shows a comparison with the effect of GSNO in normal physiological solutions (140 mM NaCl

bath; 140 mM KCl pipette solution). A significant difference lies between the effect of GSNO in Ca^{2+} -free conditions and that in normal conditions, $P < 0.01$.

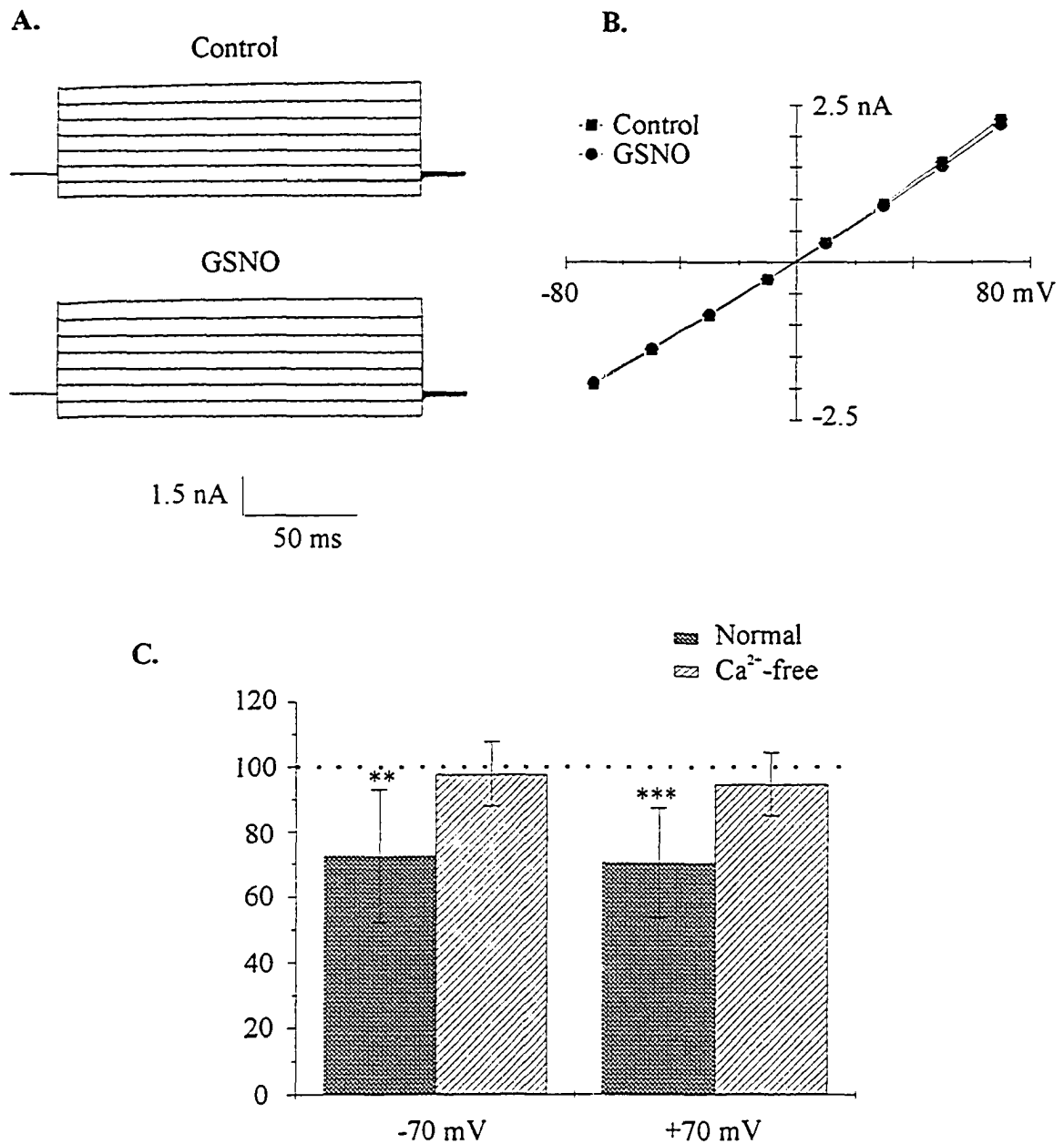
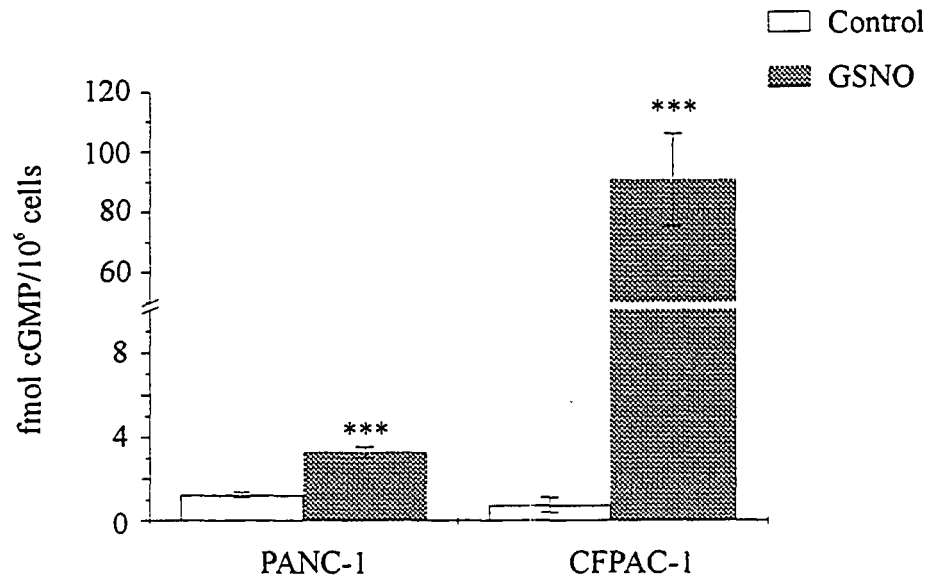

Figure 22. Depletion of Ca²⁺ from the cell inhibits the effect of GSNO in CFPAC-1 cells. **(A)** Representative recordings showing whole-cell current before and after treatment with GSNO (100 μ M) in Ca²⁺-free conditions. **(B)** Current-voltage relationships corresponding to recordings shown in panel A. **(C)** Comparative effects of GSNO in Ca²⁺-free conditions (cross-hatched bars; n=7) and normal conditions (shaded bars; n=8) at \pm 70 mV. Dotted line represents control (100%). ** P <0.01, *** P <0.001 compared to control.

5. Nitric Oxide Induces an Increase in cGMP in CFPAC-1 and PANC-1 cells.

In addition to intracellular Ca^{2+} , cGMP is a common mediator of many cellular functions. NO is the most potent and effective activator of soluble guanylate cyclase. Through binding to the heme moiety of the enzyme and by dislocating the heme-iron complex, NO induces a conformational change exposing the active site for catalytic activity (Schmidt et al., 1993). Figure 23A shows that following a 1-minute exposure of cells to GSNO (100 μM) cytoplasmic levels of cGMP are elevated in both PANC-1 and CFPAC-1 cells, compared to untreated cells (control). It is important to notice that the GSNO-mediated increase in cGMP in CFPAC-1 cells was approximately 90-fold compared to a 3-fold increase in PANC-1 cells, whereas basal levels of cGMP in both cell lines are similar. Measurement of cAMP by radioimmunoassay revealed no differences between stimulated and unstimulated cells (figure 23C).

A.



B.

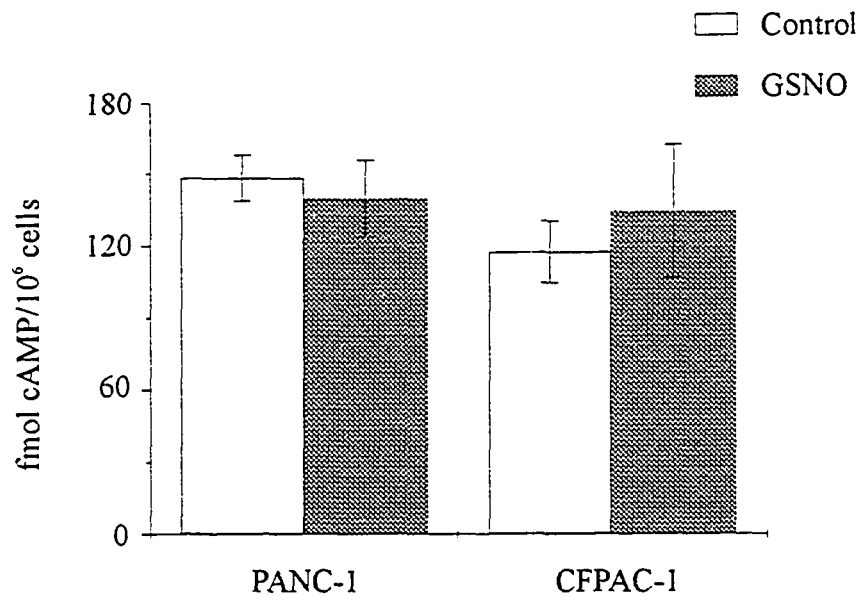

Figure 23. Intracellular cGMP levels are increased following exposure to GSNO. Histograms showing cytoplasmic levels of cGMP (A) and cAMP (B), with and without treatment of GSNO (100 mM) for 1 min. *** $P < 0.001$ compared to control, $n=4$ in all cases. Data are typical for radioimmunoassays carried out on 3 different batches of cells.

6. Soluble Guanylate Cyclase Levels in Pancreatic Duct Cells.

Soluble guanylate cyclase, GC-S (GTP pyrophosphate-lyase (cyclizing), EC 4.6.1.2) is found in the cytosolic fraction of virtually all mammalian tissues (Hobbs, 1997). GC-S exists as a heterodimer and subunits range in molecular weight from 70 kDa and 82 kDa, depending on species. Since NO is known to increase cytoplasmic cGMP by stimulating GC-S, the levels of this enzyme were measured in both cell lines using western blot analysis (Figure 24). GC-S protein expression in CFPAC-1 cells was found to be approximately 5-times higher than that in PANC-1 cells. Thus, providing a possible explanation for the considerable difference in GSNO-induced cGMP production in these cell lines.

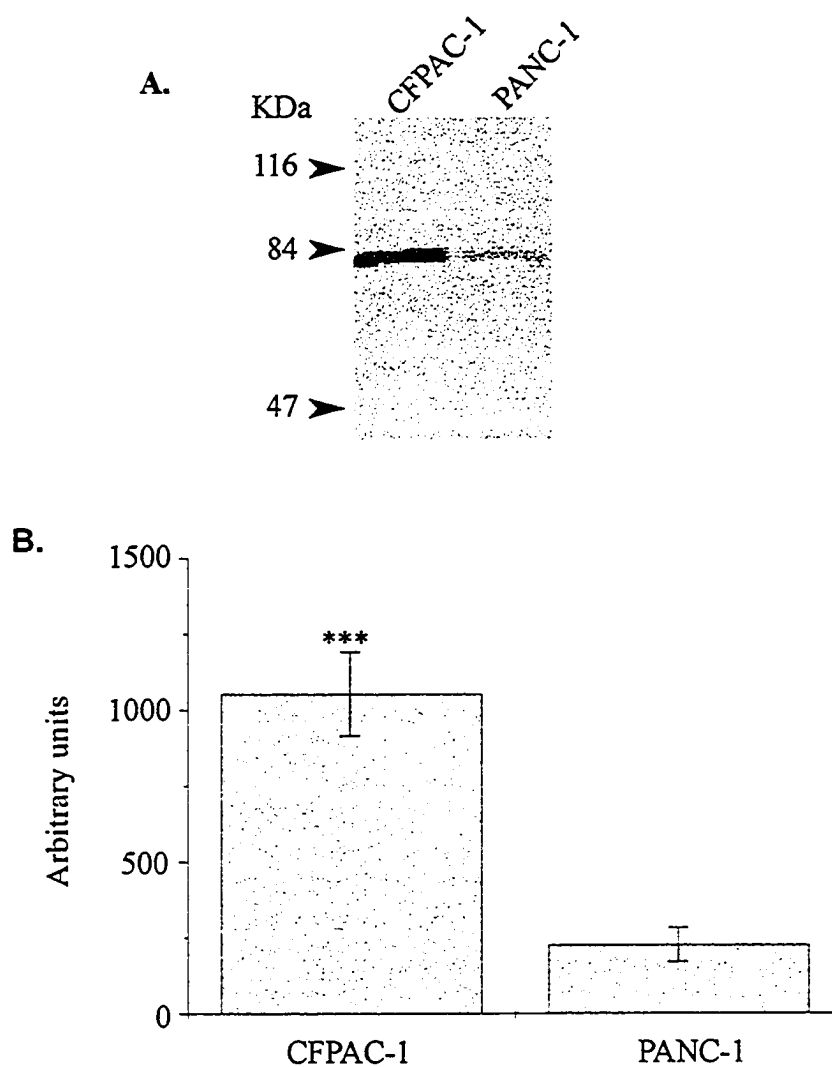

Figure 24. Soluble guanylate cyclase protein expression in pancreatic duct epithelial cells. (A) Western blot of soluble guanylate cyclase. The bands at 70-80 kDa represent the α -subunit of GC-S, detected by polyclonal antibodies. (B) Histogram showing relative band intensity, *** $P < 0.001$, $n = 3$.

7. Nitric Oxide Acts Via a cGMP-dependent Pathway.

Thus far, I have shown that pharmacological application of NO can inhibit whole-cell current in CF pancreatic duct epithelial cells and that similar treatment with NO can cause a dramatic elevation in cytoplasmic cGMP. To directly demonstrate the role of cGMP in the NO-induced inhibition of whole-cell current in CFPAC-1 cells, 8-Br-cGMP (1 mM), a membrane permeable analogue of cGMP, was added to the bath solution (figure 25). Similar to the action of GSNO, 8-Br-cGMP significantly decreased the basal whole-cell current ($P < 0.001$, $n = 7$). To determine whether cGMP action is direct or is mediated via activation of GC-S, cells were pretreated with ODQ (10 μ M), a specific inhibitor of GC-S, before applying GSNO (100 μ M) to the bath solution (figure 26). Prior application of ODQ did not alter basal current ($n = 5$) and subsequent addition of GSNO had no further effect, suggesting the involvement of GC-S in this process. Furthermore, subsequent application of 8-Br-cGMP (1 mM) in the presence of ODQ reduced the basal whole-cell current ($P < 0.001$, $n = 5$) indicating a crucial role for cGMP in NO-mediated current inhibition in CF cells.

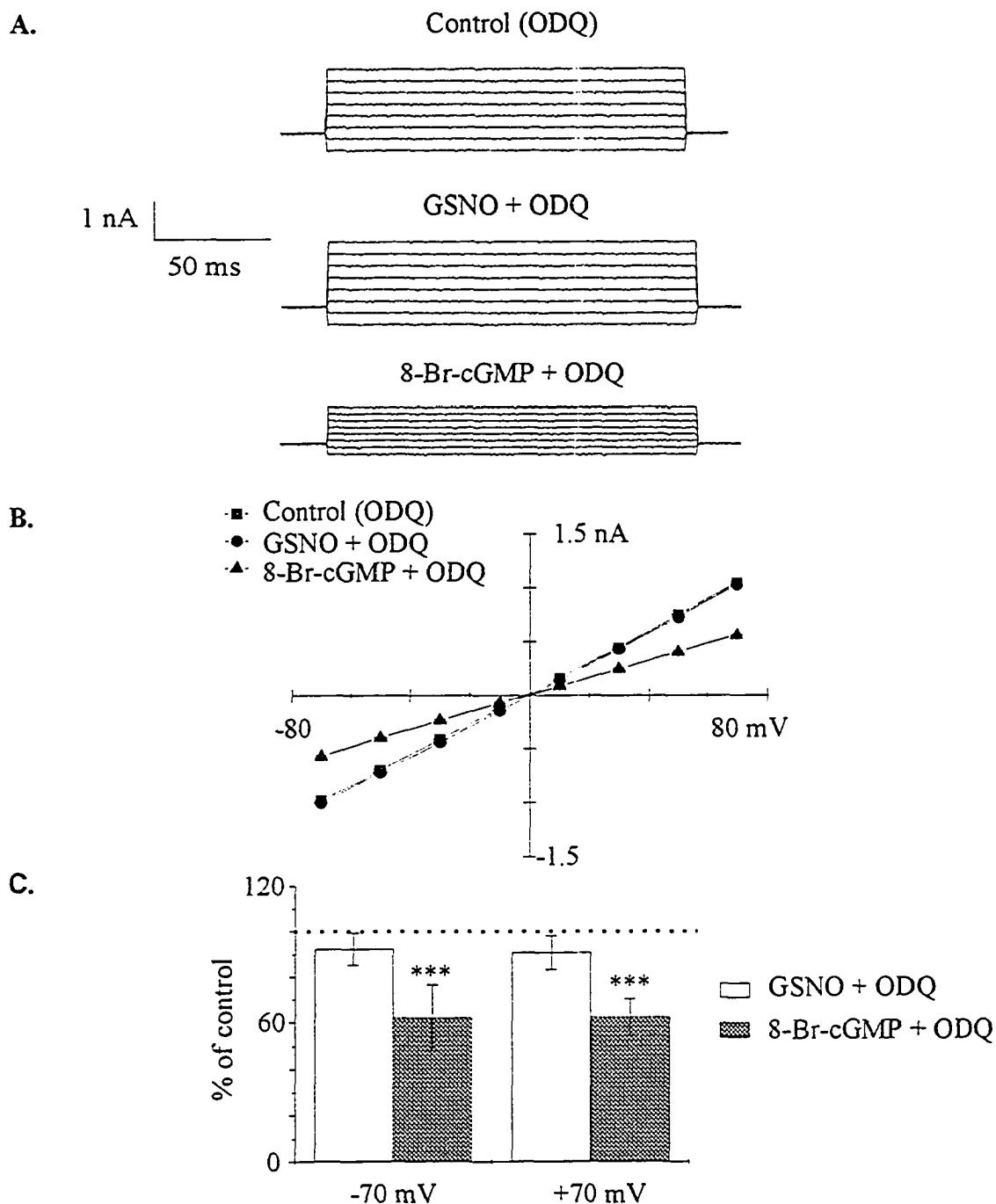

Figure 26. Inhibition of soluble guanylate cyclase eliminates the inhibitory effect of GSNO on whole-cell current in CFPAC-1. **(A)** Typical whole-cell current recordings showing the inhibitory effect of ODQ (10 μ M) and no subsequent effect of GSNO (100 μ M) when GC-S is inhibited. Addition of 8-Br-cGMP (1 mM) restores the inhibition of whole-cell current. **(B)** Corresponding I-V relationship for recordings shown in panel A. **(C)** Summarized data showing mean \pm SD. No significant difference lies between Control (ODQ) and GSNO + ODQ ($P > 0.05$). Subsequent addition of 8-Br-cGMP significantly decreased basal current ($P < 0.001$ compared with control value at ± 70 mV. Dotted line represents control value (100%). *** $P < 0.001$ compared with control value, $n = 5$ in all cases.

8. Glutathione levels in CF and non-CF cells.

Glutathione is the principal antioxidant within the cell, providing protection against increased levels of oxidative and nitrosative free radical species and other highly reactive electrophiles. To investigate the effects of NO on GSH levels in CF and non-CF cells. Figure 27 shows firstly, that there is a significant difference between GSH levels in CFPAC-1 and PANC-1 cells ($P < 0.001$, $n=3$ using a one-tailed students t -test) with levels in CF cells being higher than in non-CF cells. This suggests that there may be a difference in the basal redox state due to the CF phenotype. Secondly, after a one hour exposure to GSNO (100 μM), the GSH concentration is significantly decreased in CF cells ($P < 0.05$, $n=3$, using a one-tailed students t -test) but no change is observed in non-CF cells. This further indicates that the redox state is amplified by inflammatory levels of NO and GSH may act as an antioxidant by reacting with NO.

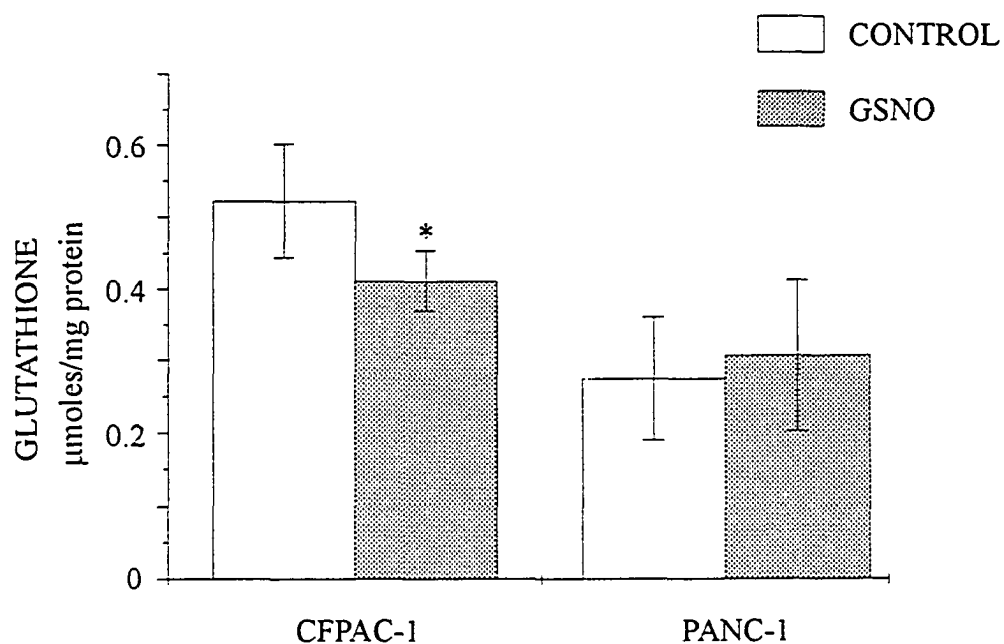

Figure 27. The effect of GSNO (100 μ M) on glutathione levels in CF and non-CF cells. PANC-1 cells display a significantly lower concentration of GSH under basal conditions than do CFPAC-1 cells ($P < 0.001$, $n = 3$). NO causes a decrease in GSH levels in CFPAC-1 cells, whereas no change was seen in PANC-1. * $P < 0.05$, $n = 3$.

Chapter V.

Discussion

The results presented in this thesis describe membrane biophysical properties of pancreas duct epithelial cells and characterize a channel regulatory pathway that is pertinent to inflammatory conditions. It is indicated here that these properties are altered or enhanced by the cystic fibrosis phenotype. The alteration of surface charge properties and the nitric oxide-induced regulation of channel function in CF secretory epithelia are shown here to be deleterious to the cell and thus may amplify the CF phenotype by inhibiting bicarbonate secretion in the pancreas duct. I will discuss the evidence in two sections: firstly, the roles of surface charge in secretory epithelia and secondly, the effects of NO in regulating ion channel function. A possible link may lie between these two phenomena and this will be presented finally as a suggested hypothesis. An alteration in channel function in secretory epithelia can have drastic effects in maintaining the fluid homeostasis within the pancreas duct and my studies reported here may significantly contribute towards a better understanding of the pathophysiology of cystic fibrosis.

A. Altered Cell Surface Charge in Cystic Fibrosis Epithelia

Using the colloid titration technique I have demonstrated that CF epithelia have a reduced negative surface charge in comparison with non-CF cells. The colloid titration technique has been used before to estimate surface charge on several different types of cells and macromolecules (Terayama, 1952; Katayama, 1978; Van Damme et al., 1992). This method gives a direct measurement of the total negative surface charge and has been extensively validated under different experimental conditions (Van Damme et al., 1994; Van Damme et al., 1992). My results indicate that CF epithelia have a reduced negative surface charge in comparison to non-CF cells. Before discussing the relevance of this

simple observation in terms of ion channel regulation, there are other potential roles of surface charge that are of importance to CF pathophysiology that must be mentioned.

The decreased negative surface charge in CF cells is consistent with increased adherence of bacterial cells to epithelia described in cystic fibrosis (Boat et al., 1989; Schwab et al., 1993). A reduction in negativity would decrease the electrostatic repulsion by causing a charge differential between cell surfaces, thereby decreasing the amount of energy needed to overcome the charge effect. This allows the cells to move closer and ultimately to adhere. This electrostatic interaction is not exclusive to bacterial cell adhesion. It has been demonstrated that adhesion of neutrophils to target cells relies on a decrease in negative surface charge, either on the neutrophil itself or on the target cell (Hoover et al., 1978). In addition, these investigators identified a requirement for divalent cations in optimizing neutrophil adhesion. This is of particular relevance to inflammatory reactions in CF, where neutrophilic inflammation is chronic in CF-induced pancreatitis (Dodge, 1998). It seems feasible to speculate that the decreased negativity on the surface of CF ductal epithelia would facilitate the localization of neutrophils within the blocked duct lumen, thus enhancing the inflammatory response in the CF pancreas. In addition, any bacteria that may migrate from the intestinal lumen into the pancreatic duct could be expected to adhere more readily to the duct epithelial surface due to more favourable electrostatic interactions.

In keeping with the concept of negative charge effects on cell adhesion, the use of cationic liposomes for gene delivery may be affected by a decrease in membrane negativity on the surface of CF epithelia. The net surface charge of the lipid-plasmid complex is a function of the relative amounts of negatively charged plasmid and cationic

liposome and most combinations result in a positive net surface potential (Schreier and Sawyer, 1996). An increase in repulsive forces may occur if the target epithelial membrane loses negative charge, thus posing a potential problem for efficient gene delivery.

As described in Chapter I, the interface formed by an electrolyte in contact with a charged surface can have important effects on ion channel function. A charged surface in the neighborhood of the channel mouth influences the concentration of ions at the channel entrance and hence its conductance. This has been demonstrated with charged amino acid residues within the channel protein. Charge selectivity filters can be formed that potentiate conductance by increasing local concentrations of particular ionic species around the mouth of the channel (Cheung and Akabas, 1997; MacKinnon et al., 1989). Voltage-dependent channels have sensors of transmembrane electrical potential and the open or closed state of these channel types is described as a function of applied transmembrane potential and the surface potential induced by any charged interfaces near the voltage sensor domain (Latorre et al., 1992). Phospholipid head groups in the surrounding membrane may play some role in regulating voltage sensitive channel domains (Green and Anderson, 1991) or influencing channel conformation (Lundbaek et al., 1997). Sialic acid has also been shown to contribute to channel regulation through surface charge interactions with voltage sensing machinery (James and Agnew, 1987; Recio-Pinto et al., 1990). Therefore changes in surface potential, such as those found in CFPAC-1 cells, can be predicted to have profound effects on channel function.

A decrease in negative surface charge, as found in CF epithelia, leads to a decrease in surface potential (Latorre et al., 1992). This consequently leads to a shift in the activation

voltage of hyperpolarization-activated channels in a positive direction. As the membrane becomes more positively charged, it is already causing small hyperpolarization, thus a smaller positive voltage across the membrane is required for channel activation. Hyperpolarization of the basolateral membrane in pancreatic duct epithelia leads to Cl^- accumulation within the cell (Gabriel and Boucher, 1997). It would seem appropriate to speculate that the decreased negative surface charge on CF cells leaves them 'primed' for basolateral membrane hyperpolarization by action of K^+ conductance across this membrane (Sohma et al., 1996). However, in the absence of CFTR Cl^- channels in the apical membrane, Cl^- concentration within the cell exceeds its electrochemical equilibrium. Na^+ reabsorption across the apical membrane may then be stimulated to maintain electroneutrality in the cytoplasm and concomitant water reabsorption leads to dehydrated, $\text{HCO}_3^-/\text{Cl}^-$ deficient fluid in the pancreatic duct. Therefore, the decreased negativity on the surface of CF epithelia may amplify the CF defect.

Direct measurement of channel conductance as a function of surface charge has recently been demonstrated on gramicidin A channels, incorporated into liposomes. Lipid bilayer charge was manipulated by diluting negatively charged phosphatidylserine with neutral phosphatidylcholine lipids. The loss of negative surface potential, led to a decrease in channel conductance at fixed pH and this was shown to be due to repulsive forces of like-charges at the membrane surface and in the surrounding solution, the extent of the effect was quantified by the Gouy-Chapman theory (Rostovtseva et al., 1998). This observation must also be considered as a potential mechanism by which channel function can be affected by the decrease in negative surface charge, shown in CF epithelia. According to the ductal secretory model proposed by Sohma *et al.* (Sohma et al., 1996),

the basolateral sodium conductance depolarizes the potential difference across the basolateral membrane and also affects the magnitude of depolarization when K^+ conductance is reduced. A possible decrease in basolateral Na^+ conductance may occur if there is loss of negative surface charge around the channel pore, as predicted by the Gouy-Chapman theory. This could lead to a shift of the basolateral membrane potential towards a more hyperpolarized voltage, thus presenting another mechanism by which the cell is 'primed' for Cl^- uptake and subject to the consequences described above.

Surface charge on both CF and non-CF epithelia decreased with increasing passage number, reminiscent of erythrocyte aging (Dhermy et al., 1987). However, the decreased negativity of CF cells compared to non-CF cells remained significant throughout the period of culture. The defective acidification hypothesis, described in Chapter 1, implicated dysfunctional CFTR in the reduction of sialic acid residues on secreted mucins in CF epithelial secretions (Barasch and Al-Awqati, 1993). Thus, it seemed plausible that the difference in surface charge between CFPAC-1 and PANC-1 cells may be due to altered sialylation of membrane bound components.

Neuraminidase treatment removed approximately the same amount of surface charge from both cell lines. This result was supported by the complementary measurements of the amount of N-acetylneuraminic acid released by neuraminidase. Thus, sialic acid residues are not involved in the reduction of negative surface charge in CF. This conclusion supports previous studies by Boat et al. (Boat et al., 1989) who found no differences in sialic acid content in respiratory mucins from normal and CF cells, but not other observations that undersialylation occurs in CF mucus (Barasch and Al-Awqati, 1993). However, these experiments cannot be directly compared, since both these authors

measured sialylation of secreted proteins, whereas results presented here characterize cell membrane components.

Presently, the identity of other membrane molecules that contribute to surface charge in normal and CF cells remains unknown. Further studies to identify such molecular groups may involve measurement of sulfated glycosaminoglycans, as these macromolecules have been identified as negative charge carriers on the membrane surface (Vargas et al., 1990). However, according to the defective acidification hypothesis, secreted glycoproteins are oversulfated in CF tissue (Barasch and Al-Awqati, 1993) and this would be expected to present as an elevation in the negativity of CF epithelial cells. Lipid peroxidation has previously been demonstrated to cause a decrease in negative surface charge on intestinal brush border membranes (Ohyashiki et al., 1993; Ohyashiki et al., 1994). Furthermore, the accumulation of lipid hydroperoxides has been identified as a characteristic of aging in some cell types (Carrera-Rotllan and Estrada-Garcia, 1998). Therefore, an increase in these membrane components may explain differences in surface charge between CF and non-CF cells and also the decrease in membrane negativity, observed with increasing time in culture. The concept of lipid peroxidation being increased in CF epithelia will be discussed further at the end of this chapter.

In summary, I have shown that CF pancreatic duct epithelia display reduced negativity on the membrane surface as compared to non-CF cells. Sialic acid contributes significantly to this negative surface charge in both cell types, although levels removed by neuraminidase treatment are similar in both CF and non-CF cells. This is contrary to the predictions of the defective acidification hypothesis (Barasch and Al-Awqati, 1993),

but supports previous studies showing no change in mucin glycosylation in CF secretions (Boat et al., 1989). Although the identity of other membrane molecules that contribute to surface charge in normal and CF epithelia are currently unknown, one can make predictions as to the consequences of this altered surface potential in CF cells, particularly in terms of ion channel function. Decreases in negative surface charge in CF duct epithelia may amplify the CF defect by increasing neutrophil localization and by inhibiting transepithelial ion movement.

B. Nitric Oxide Inhibits Whole-Cell Current in CF Pancreatic Epithelial Cells

The evidence presented in this study strongly suggests that an increased level of NO in pancreatic duct epithelium significantly reduces basal current in cells from CF patients. In contrast, NO has no effect on the whole-cell current in non-CF pancreatic cells. I have shown that NO exerts its effects via a cGMP-dependent pathway and the most likely targets of its action are DIDS-sensitive Cl⁻ channels and charybdotoxin-sensitive K⁺ channels. Furthermore, CF cells contain elevated levels of GC-S, as compared to non-CF cells.

The application of the nitric oxide donor, GSNO caused an inhibition of whole-cell current in CFPAC-1 cells. This effect was confirmed to be the result of NO, by similar whole-cell current inhibition when SNAP, a NO donor that is chemically unrelated to GSNO, was applied. However, no effect of GSNO on whole-cell current was seen in the corresponding non-CF cell line PANC-1. The major difference between these two cell lines is that CFPAC-1 is derived from a CF patient and PANC-1 from a non-CF patient

(Schoumacher et al., 1990; Madden and Sarras, 1988). The differing effects of GSNO on whole-cell current raises the possibility that this NO-induced ion channel modulation may be caused by the cystic fibrosis phenotype. GSNO applied to A549 cells has previously been shown to cause a cGMP-dependent increase in non-CFTR Cl⁻ conductance (Kamosinska et al., 1997), measured using the same perforated patch-clamp technique as in my studies presented here. These type II pneumocytes also lack CFTR mRNA (Renier et al., 1995) and are obtained from non-CF tissue. Therefore, in this respect A549 are comparable to PANC-1 cells. The differences in basal whole-cell current response to NO between PANC-1 and A549 cells, suggests that there may be a tissue-type distinction in NO-induced whole-cell current regulation in addition to the CF pathological distinction described above.

Many other studies have shown that NO can cause an increase in ion movement (Wilson et al., 1994; White et al., 1993; Sakai et al., 1995), although these studies were carried out using different cell types and methods, thus making direct comparisons to my studies on pancreatic duct epithelia difficult. Inhibitory effects on ion conductance have also been observed following the application of NO donors, but again, many different cell models and methods have been utilized to observe such effects and a variety of channel types are affected (Krippet-Drews et al., 1995; Jain et al., 1998; Guo et al., 1998; Lu and Wang, 1998).

The concentration of NO donors used in our study is likely to yield NO at concentrations similar to those encountered in the native tissues. Although NO concentration in the pancreas has not been measured directly it has recently been shown that NOS activity is increased under inflammatory conditions (Al-Mufti et al., 1998).

Direct measurement of NO has been carried out on a variety of cell types, for example, macrophages produce 0.1 nM/(min 10^6 cells) of NO (Ischiropoulos et al., 1992) which may generate μ M concentrations in surrounding tissue. Similarly, 2-4 μ M of NO were reported in brain during cerebral ischemia (Malinski et al., 1993), and \sim 0.3 μ M of NO in mesenteric resistance arteries (Tschudi et al., 1996). In addition, it has been shown that 100 μ M SNAP generates a stable NO concentration of 0.1 μ M at 25°C (Ichimori et al., 1994). Therefore, it is reasonable to assume that concentrations of NO produced by NO donors in our study are similar to those found in pancreatic tissues, especially, under inflammatory conditions (Scheele et al., 1996).

While CFPAC-1 cells have increased activity of Ca^{2+} -dependent NOS as compared to that in PANC-1 cells, the fact that L-NAME had no apparent effect on basal current suggests that tonically generated NO is not involved in the regulation of transepithelial secretion. However, the elevated levels of NO during inflammation would be detrimental to ion transport in CF, but not in control tissues. In some cell types, NO at physiological levels has different cellular effects than when elevated by the inducible NOS isoform, or by application of pharmacological NO donors (Schmidt et al., 1993). *In vivo* experiments involving caerulein-induced pancreatitis in rats showed that pharmacologically applied NO reduced basal fluid secretion in the pancreas, whereas L-NAME had no effect (Molero et al., 1995). This is in agreement with my data showing that exogenous NO inhibits whole-cell current, whereas endogenously produced NO may be of some significance to other cellular processes in CFPAC-1 cells, but is not consequential to my observations on whole-cell current.

NO has been shown to regulate several different channel types in epithelial tissues, including amiloride-sensitive sodium channels (Jain et al., 1998), cGMP-gated channels (Biel et al., 1998), non-CFTR Cl⁻ channels (Kamosinska et al., 1997) and small conductance K⁺ channels (Lu and Wang, 1996). Both, cGMP-dependent and -independent mechanisms have been implicated in this regulation (Kourie, 1998). My data indicate that amiloride-sensitive cation channels contribute significantly to the basal whole-cell current in CF pancreatic ductal epithelium, but that their function is not affected by NO. The mathematical secretory model proposed by Sohma *et al.* (Sohma et al., 1996) predicts the presence of a sodium conductance in pancreatic duct epithelia. However, the exact identity of this channel has yet to be elucidated and my data indicate that this may be a non-specific cation channel. The absence of amiloride-sensitive, sodium-selective channels (i.e. ENaC) in pancreatic duct epithelia has also been reported elsewhere (Cotton, 1998).

The expression of cyclic nucleotide gated channels is both tissue and species specific (Distler et al., 1994) and NO has been shown to be a major physiological regulator of their function (Biel et al., 1998). The cGMP-gated channels contribute to electrolyte secretion in tissues such as tracheal epithelium (Schwiebert et al., 1997) or kidney (Distler et al., 1994), and are potential targets for the regulation of ion movement by NO. However, our data indicate that in pancreatic ductal epithelium, cyclic nucleotide gated channels do not contribute significantly to the basal whole-cell current and are not affected by NO donors.

Chloride current has been shown to dominate the basal whole-cell current in pancreatic duct epithelial cells including CFPAC-1 cells (Winpenny et al., 1998; Warth

and Greger, 1993). In asymmetric cation solutions, duct epithelia commonly express a linear/slightly outwardly rectifying Ca^{2+} -dependent Cl^- conductance, which dominates the whole-cell current (Winpenny et al., 1998). This corroborates the linear current-voltage relationships reported here. DIDS-sensitive Cl^- channels in CFPAC-1 cells have shown to be activated by Ca^{2+} -mobilizing agents such as neurotensin, ATP or carbachol (Warth and Greger, 1993) and inhibited by agents that stimulate production of inositol 3,4,5,6-tetrakisphosphate (Ho et al., 1997). My studies show that these channels are also a target for NO action in CFPAC-1 cells. As mentioned above, it is interesting to note that NO has been shown to activate the non-CFTR Cl^- channels in gastric parietal cells (Sakai et al., 1995) and in lung epithelial cells (Kamosinska et al., 1997), suggesting tissue specific effects on Cl^- current.

My data also show that the NO-dependent regulation of pancreatic epithelial K^+ channels is affected by the CF phenotype. NO inhibits K^+ channels in CF but not in control cells. CFPAC-1 cells have been shown to possess ATP-sensitive K^+ channels regulated by intracellular calcium and cAMP-dependent phosphorylation that were inhibited by charybdotoxin (Roch et al., 1995). Therefore, it is likely that these channels are sensitive to NO in CF. The coupling of K^+ and Cl^- movement in intact epithelia, has previously been demonstrated under stimulated secretory conditions (McCann and Welsh, 1990; Mandel et al., 1986; Weymer et al., 1985). If Cl^- secretion is decreased a corresponding decrease in K^+ conductance is expected and visa versa. This postulates physiological consequences of inhibiting K^+ or Cl^- conductances by NO in pathological states.

The depletion of Ca^{2+} from CFPAC-1 cells attenuated the effect of NO on whole-cell

current. This is consistent with previous observations in pancreatic duct epithelia that show secretory processes to be Ca^{2+} -dependent (Case and Argent, 1993; Evans et al., 1996; Ashton et al., 1993; Chan et al., 1996). Nitric oxide is capable of reducing intracellular Ca^{2+} levels by direct or indirect mechanisms as described in Chapter I, thus it is reasonable to hypothesize that NO inhibits whole-cell current by reducing intracellular Ca^{2+} levels and consequently decreasing Ca^{2+} -stimulated ion conductances.

In addition to Ca^{2+} being a NO-regulated second messenger pathway in CFPAC-1 cells, I have shown that a cGMP-dependent pathway also mediates NO-induced inhibition of whole-cell current in CFPAC-1 cells. Evidence for this is as follows: 1) application of 8-Br-cGMP produced a similar effect to that of NO, 2) a correlation was seen between the inhibition of whole-cell current and cGMP levels following NO treatment, and 3) the elimination of the inhibitory effects of NO by pre-incubation of cells with a selective inhibitor of soluble guanylyl cyclase, ODQ. The observation that NO induces a 90-fold increase in cGMP in CFPAC-1 cells, but only a 3-fold increase in PANC-1 cells is consistent with similar measurements in CF mice compared to wild-type restored mice (Kelley and Drumm, 1998b). These authors suggested that the hypersensitivity of CF airways to exogenous NO is due to an upregulation of GC-S. My data support this conclusion by showing that the amount of GC-S in CF pancreatic epithelia is, indeed, elevated compared to that in non-CF epithelia.

cGMP-independent mechanisms cannot be ruled out of conclusions from this investigation. It is possible that at such high concentrations of NO, the inhibitory effects on channel function could be the result of the redox status within the cell, as concluded by previous studies (Lu and Wang, 1998; Krippet-Drews et al., 1995). Calcium-

dependent K^+ channels in bovine endothelial cells can be inhibited by oxidative agents and conductance is restored by reducing thiol groups on the channel protein (Cai and Sauvé, 1997). This demonstrates that Ca^{2+} -dependent K^+ channels are susceptible to oxidative inhibition by NO.

In summary, I have shown that increased levels of NO in CF pancreatic ductal epithelia have deleterious effects on ion transport by specifically targeting DIDS-sensitive Cl^- channels and charybdotoxin-sensitive K^+ channels, via a cGMP-dependent pathway. It is likely that increased levels of NO in pancreatic epithelium, as may be observed under inflammatory conditions, contribute to the CF phenotype by inhibiting transepithelial ion movement and pancreatic enzyme secretion.

C. Altered Redox Status in CF Pancreatic Duct Epithelia: A Hypothesis.

My results presented in this thesis cover two aspects of channel regulation, negative surface charge and the effects of nitric oxide in pancreatic duct epithelial cells. I have shown that regulatory mechanisms controlled by these factors may be altered by the cystic fibrosis phenotype and as a result can be predicted to amplify the dysfunctional secretion of bicarbonate-rich fluid in to the pancreas duct lumen by inhibiting ion channel function. In this section I propose a hypothesis based on how evidence documented by other investigators, concerning the redox status in CF tissues may be connected to the potentially detrimental effects of negative surface charge and elevated levels of NO in bicarbonate secretion in the pancreas.

The redox status within a cell represents a fine balance between free-radical scavenging antioxidants, antioxidant enzymes and highly reactive oxidative species (figure 28). Oxidative stress that might be encountered, for example during inflammation, leads to depletion of antioxidant components. Significant loss of such molecules leads to cellular damage and eventual cell death (Sciuto, 1997). Glutathione is the cell's principal defense against oxidative stress. This antioxidant tripeptide is primarily involved in forming conjugates with reactive electrophiles to render them non-toxic and more excretable. Glutathione-S-transferase is capable of detoxifying potent oxidative molecules by catalyzing the formation of conjugates with glutathione (Groppi et al., 1991). As the cell becomes oxidatively stressed, GSH is oxidized to GSSG and GSH reductase and peroxidase enzymes catalyze the recycling of GSH. Thus, as the cell becomes more oxidatively stressed and GSH becomes oxidized, the ratio of GSH to GSSG decreases (Sciuto, 1997). Depletion of GSH from the cell compromises the cell's ability to detoxify the highly reactive metabolic intermediates formed during oxidative stress, but the antioxidant enzymes such as glutathione-S-transferase and glutathione reductase and peroxidase are also key players in maintaining a balanced redox state within the cell.

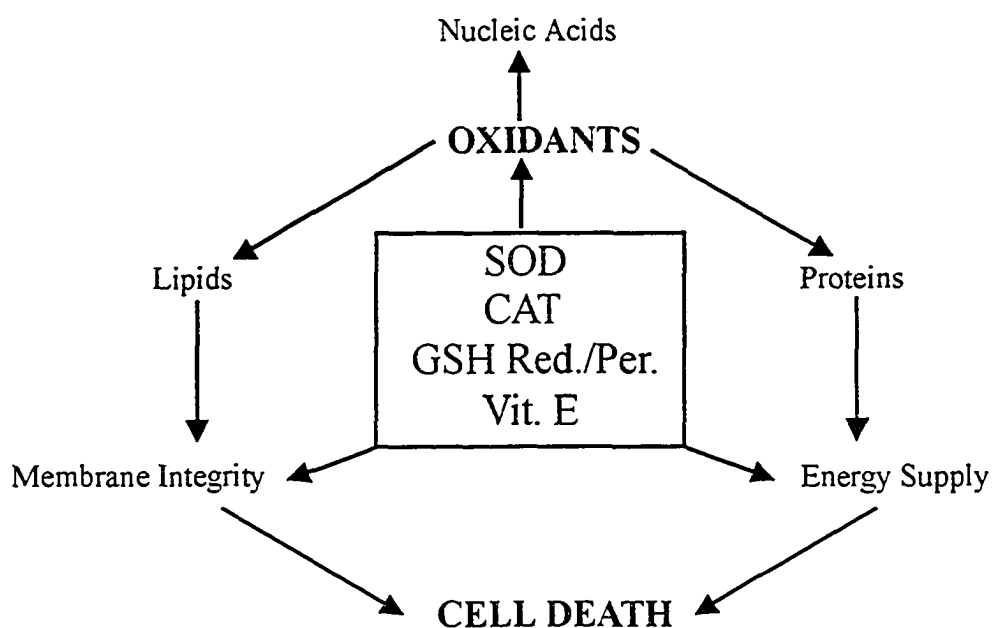

Figure 28. Oxidative stress can deplete free radical scavenging antioxidants and enzymes listed in the box. SOD = superoxide dismutase, CAT = catalase, GSH Red/Per = glutathione reductase/oxidase, Vit. E = vitamin E. Modified from (Sciuto, 1997).

Synthesis of GSH within the pancreas has recently been localized to duct epithelial cells within the exocrine pancreas (Neuschwander-Tetri et al., 1997). γ -glutamylcysteine synthetase (GCS) is the enzyme responsible for the catalytic formation of GSH within the cell from precursor amino acids. The activity of GCS can be elevated by application of reagents that induce oxidative stress in the pancreas (Neuschwander-Tetri et al., 1997). Furthermore, glutathione *S*-transferases (GSTs), a group of isoenzymes that catalyze the interaction of GSH with a wide variety of reactive electrophiles, has also been localized to the duct system of the exocrine pancreas (March et al., 1998). This evidence together,

suggests that GSH acts as cytoprotectant in the pancreas, especially within the ductal regions.

My final set of data, presented in Chapter IV shows that CFPAC-1 and PANC-1 also produce GSH and levels are comparable to those reported by others in pancreatic cells (Neuschwander-Tetri et al., 1997). However, levels in CF cells are significantly elevated as compared to those in non-CF cells. Earlier, I showed that constitutive NOS activity is also elevated in CF cells, implying increased levels of NO, in the absence of external stimuli. A suitable conjecture, combining these observations is that continually elevated levels of NO induces oxidative stress within the cell and this, in turn stimulates activity of GCS to produce more GSH as a cytoprotective measure. Sudden exposure of the cells to GSNO, comparable to oxidative stress experienced during inflammation of the pancreas, induces a decrease in GSH levels in CF epithelia, whereas no change is seen in non-CF cells. This suggests that although GSH is initially present to cope with oxidative stress within the cell, the regeneration/recycling of GSH is not efficient enough to maintain the levels required for redox balance in CF cells. This is consistent with findings that GSH levels are deficient in CF lung epithelial lining fluid (Roum et al., 1993) and that oxidative stress contributes to the pathophysiology of CF (Mandel et al., 1986).

An event correlated with GSH depletion is lipid peroxidation (Sciuto, 1997). GSH can act as a detoxifier and can break up the propagation of this chain reaction. It has recently been shown that induction of pancreatitis by stimulating high levels NO production causes a sizeable elevation in lipid peroxidation and GSH. Furthermore, an altered antioxidant status in CF patients has been reported to be the precipitating cause of increased lipid peroxidation products in CF plasma (Portal et al., 1995). With this in

mind, I hypothesize that altered antioxidant status in CF pancreatic duct epithelia may lead to increased lipid peroxidation. It has also been shown that lipid peroxidation causes an increase in positive charge on the membrane surface of porcine brush border vesicles (Ohyashiki et al., 1993). Thus, the hypothesis that an altered antioxidant status in CF epithelia amplifies the CF phenotype may unify my findings presented in this thesis, firstly by explaining the decreased membrane negative charge in CFPAC-1 cells. An increase in oxidizing free radicals, such as NO can initiate and propagate high levels of lipid peroxidation, which in turn can alter surface charge. This effect would be amplified if the cell lacks natural antioxidant defense mechanisms, such as GSH. Secondly, altered surface charge may lead to altered channel conductance through to electrostatic interactions. Lipid peroxidation leaves the cell more susceptible to further oxidative reactions resulting from a decrease in antioxidantizing components. A recent report has evaluated cGMP as cytoprotective factor during lipid peroxidation (Keller et al., 1998). This further validates my hypothesis, by accounting for the large increase in NO-induced cGMP in CF as compared to non-CF cells, which may be considered as a compensatory antioxidant measure.

D. Conclusion and Future Directions

The secretion of a bicarbonate-rich fluid into the ductal lumen of the exocrine pancreas enables efficient transfer and function of digestive enzymes into the intestinal tract. The secretion of this fluid is dependent upon ion channel function in the epithelial membrane. Ductal blockage, primarily by the precipitation of secreted proteins is characteristic of CF. Secondary diseases such as pancreatitis are prevalent in CF patients

and chronic inflammation also contributes significantly to CF pathophysiology. All these pathological factors are shown to be precipitated by dysfunctional CFTR in the ductal epithelium. Recent suggestions have been made in an attempt to consulate the complexities of CF, that factors other than CFTR may play a role in amplifying the CF defect. My thesis has dealt with two mechanisms of ion channel regulation in ductal epithelial cells: negative surface charge and effects of elevated NO concentration and has shown that both these phenomena are different in CF as compared to a non-CF status.

I have used two human pancreas duct epithelial cell lines, PANC-1 and CFPAC-1 as models of normal and CF epithelial cells, respectively. The measurement of surface charge showed that membrane negativity is decreased in CF cells and that this difference between CF and non-CF epithelia is not due to sialic acid residues on the membrane surface. A change in negative surface potential is known to alter ion movement across the cell membrane, therefore, this simple observation is crucial in understanding pathological factors that may contribute to or amplify the CF defect.

Whole-cell patch-clamp studies revealed different responses to NO in CF and non-CF cells. Elevation of NO to levels that would be expected in inflammatory states prevalent in CF, inhibited whole-cell current in CF cells, but not in non-CF epithelia. The mechanism of action of NO was shown to be cGMP-dependent and the involvement of intracellular calcium was also shown in these studies. This led me to conclude that elevated levels of NO, due to chronic inflammation of the pancreas, contributes to the CF phenotype by inhibiting transepithelial ion movement and pancreatic enzyme secretion.

My experiments showing the altered levels of constitutive NOS activity and GSH levels in CF cells has led me to hypothesize that the redox status is disrupted in CF duct

cells. Data from other investigators showing altered antioxidant levels and increased oxidative reactions in CF patients have validated this hypothesis. Additional studies are needed to elucidate further, any such alterations in CF pancreatic duct epithelia. The measurement of reduced:oxidized glutathione ratio (GSH:GSSG) should first be addressed. This can be done using a slightly altered method described in Chapter III. This, together with chemiluminescent measurements of free radical species and the effects of antioxidant enzymes, such as catalase and superoxide dismutase, will give an accurate picture of the redox state in CF pancreatic duct cells. Measurement of lipid peroxidation markers, such as thiobarbituric acid reactive species including malondialdehyde would give an indication of the significance of this product of oxidative stress in CF pancreatic epithelial cells and how it may play a role in ion channel regulation.

Bibliography

- Ackerman, M.J. and Clapham, D.E. (1997). Ion channels-basic science and clinical disease [published erratum appears in *N Engl J Med* 1997 Aug 21;337(8):579]. *New England Journal of Medicine* 336, 1575-1586.
- Al-Mufti, R.A., Williamson, R.C.N., and Mathie, R.T. (1998). Increased nitric oxide activity in a rat model of acute pancreatitis. *Gut* 43, 564-570.
- Al-Nakkash, L. and Cotton, C.U. (1997). Bovine pancreatic duct cells express cAMP- and Ca^{2+} -activated apical membrane Cl^{-} conductances. *Am.J.Physiol.Gastrointest.Liver Physiol.* 273, G204-G216
- Aminoff D. (1961). Methods for the quantitative estimation of N-acetylneuraminic acid and their application to hydrolysates of sialomucoids. *Biochem.J.* 81, 384-392.(Abstract)
- Andersen, D.H. (1938). Cystic fibrosis of the pancreas and its relation to celiac disease. *Am.J.Dis.Child.* 56, 344-399.
- Anderson, M.P. and Welsh, M.J. (1992). Regulation by ATP and ADP of CFTR chloride channels that contain mutant nucleotide-binding domains [published erratum appears in *Science* 1992 Dec 11;258(5089):1719]. *Science* 257, 1701-1704.
- Arnelle, D.R. and Stamler, J.S. (1995). NO^{+} , NO, and NO^{-} donation by S-nitrosothiols: implications for regulation of physiological functions by S-nitrosylation and acceleration of disulfide formation. *Archives of Biochemistry & Biophysics* 318, 279-285.
- Arreola, J., Melvin, J.E., and Begenisich, T. (1995). Inhibition of Ca^{2+} -dependent Cl^{-} channels from secretory epithelial cells by low internal pH. *J.Membr.Biol.* 147, 95-104.
- Ashton, N., Evans, R.L., Elliott, A.C., Green, R., and Argent, B.E. (1993). Regulation of fluid secretion and intracellular messengers in isolated rat pancreatic ducts by acetylcholine. *J.Physiol.(Lond.)* 471, 549-562.
- Barasch, J. and Al-Awqati, Q. (1993). Defective acidification of the biosynthetic pathway in cystic fibrosis. *J.Cell Sci.* 117, 229-233.(Abstract)
- Barasch, J., Kiss, B., Prince, A., Saiman, L., Gruenert, D., and Al-Awqati, Q. (1991). Defective acidification of intracellular organelles in cystic fibrosis. *Nature* 352, 70-73.

- Barbry, P. and Hofman, P. (1997). Molecular biology of Na⁺ absorption. *Am.J.Physiol.Gastrointest.Liver Physiol.* 273, G571-G585
- Baro, I., Roch, B., Hongre, A.S., and Escande, D. (1994). Concomitant activation of Cl⁻ and K⁺ currents by secretory stimulation in human epithelial cells. *J.Physiol.(Lond.)* 478 Pt 3, 469-482.
- Barrett, K.E. (1997). Positive and negative regulation of chloride secretion in T84 cells. *Am.J.Physiol.* 265, C859-C868
- Bear, C.E., Li, C., Galley, K., Wang, Y., Garami, E., and Ramjeesingh (1997). Coupling of ATP hydrolysis with channel gating by purified, reconstituted CFTR. *Journal of Bioenergetics & Biomembranes* 29, 465-473.
- Bear, C.E., Li, C.H., Kartner, N., Bridges, R.J., Jensen, T.J., Ramjeesingh, M., and Riordan, J.R. (1992). Purification and functional reconstitution of the cystic fibrosis transmembrane conductance regulator (CFTR). *Cell* 68, 809-818.
- Bebök, Z., Venglarik, C.J., Pánczél, Z., Jilling, T., Kirk, K.L., and Sorscher, E.J. (1998). Activation of $\Delta F508$ CFTR in an epithelial monolayer. *Am.J.Physiol.Cell Physiol.* 275, C599-C607
- Becq, F., Fanjul, M., Mahieu, I., Berger, Z., Gola, M., and Hollande (1992). Anion channels in a human pancreatic cancer cell line (Capan-1) of ductal origin. *Pflugers Archiv - European Journal of Physiology* 420, 46-53.
- Beesley, A.H., Hardcastle, J., Hardcastle, P.T., and Taylor, C.J. (1996). Sodium/glucose cotransporter activity in cystic fibrosis. *Arch.Dis.Child.* 75, 170-170.
- Beesley, A.H., Hardcastle, J., Hardcastle, P.T., and Taylor, C.J. (1997). Potassium and sodium dependent glucose transport: Implications for cystic fibrosis. *Arch.Dis.Child.* 76, 478-478.
- Bell, J.E. and Miller, C. (1984). Effects of phospholipid surface charge on ion conduction in the K⁺ channel of sarcoplasmic reticulum. *Biophys.J.* 45, 279-287.
- Bennett, E., Urcan, M.S., Tinkle, S.S., Koszowski, A.G., Levinson, and SR (1997). Contribution of sialic acid to the voltage dependence of sodium channel gating. A possible electrostatic mechanism. *J.Gen.Physiol.* 109, 327-343.
- Biel, M., Sautter, A., Ludwig, A., Hofmann, F., and Zong, X. (1998). Cyclic nucleotide-gated channels - mediators of NO:cGMP-regulated processes. *Naunyn-Schmiedeberg's Arch.Pharmacol.* 358, 140-144.
- Bischof, G., Brenman, J., Bredt, D.S., and Machen, T.E. (1995). Possible regulation of capacitative Ca²⁺ entry into colonic epithelial cells by NO and cGMP. *Cell Calcium* 17, 250-262.

- Biwersi, J., Emans, N., and Verkman, A.S. (1996). Cystic fibrosis transmembrane conductance regulator activation stimulates endosome fusion *in vivo*. *Proc.Natl.Acad.Sci.USA* 93, 12484-12489.
- Blank, M. (1987). The surface compartmental model: A theory of ion transport focused on ionic processes in the electrical double layers at membrane protein surfaces. *Biochim.Biophys.Acta* 906, 277-294.
- Blank, U., Clauss, W., and Weber, W.M. (1995). Effects of benzamil in human cystic fibrosis airway epithelium. *Cell.Physiol.Biochem.* 5, 385-390.
- Boat, T.F., Welsh, M.J., and Beaudet, A.L. (1989). Cystic Fibrosis. In *The Metabolic Basis of Inherited Disease*. C.L.Sriver, A.L.Beaudet, W.S.Sly, and D.Valle, eds. (New York: McGraw-Hill), pp. 2649-2680.
- Boucher R.C. (1999). Status of gene therapy for cystic fibrosis lung disease. *J.Clin.Invest.* 103, 441-445.
- Boucher R.C., Cheng, E.C.H., Paradiso, A.M., Stutts M.J., Knowles, M.R., and Earp, H.S. (1989). Chloride secretory response of cystic fibrosis human airway epithelia: preservation of calcium but not protein kinase C- and A- dependent mechanisms. *J.Clin.Invest.* 84, 1424-1431.
- Bradbury, N.A., Jilling, T., Berta, G., Sorscher, E.J., Bridges, R.J., and Kirk, K.L. (1992). Regulation of plasma membrane recycling by CFTR. *Science* 256, 530-532.
- Breitwieser, G.E. (1996). Mechanisms of K⁺ channel regulation. *J.Membr.Biol.* 152, 1-11.
- Brown, C.R., Hong-Brown, L.Q., and Welch, W.J. (1997). Strategies for correcting the delta F508 CFTR protein-folding defect. *Journal of Bioenergetics & Biomembranes* 29, 491-502.
- Bucossi, G., Nizzari, M., and Torre, V. (1997). Single-channel properties of ionic channels gated by cyclic nucleotides. *Biophys.J.* 72, 1165-1181.
- Cai, S. and Sauvé, R. (1997). Effects of thiol-modifying agents on a K(Ca²⁺) channel of intermediate conductance in bovine aortic endothelial cells. *J.Memb.Biol.* 158, 147-158.
- Canessa C.M., Schlid, L., Buell, G., Thorens, B., Guatschi, I., Horisberger, J.-D., and Rossier B.C. (1994). Amiloride-sensitive epithelial Na⁺ channel is made of three homologous subunits. *Nature* 367, 463-467.
- Carew, M.A. and Thorn, P. (1996). Identification of ClC-2-like chloride currents in pig pancreatic acinar cells. *Eur.J.Physiol.* 433, 84-90.

- Carrera-Rotllan, J. and Estrada-Garcia, L. (1998). Age-dependent changes and interrelations of number of cells and biochemical parameters (glucose, triglycerides, TBARS, calcium, phosphorus) in cultured human vein endothelial cells. *Mechanisms of Ageing & Development* 103, 13-26.
- Case, R.M. and Argent, B.E. (1993). Pancreatic duct cell secretion: control and mechanisms of transport. In *The Pancreas: biology, pathobiology and disease*. V.L.W. Go, E.P. Dimagno, J.D. Gardner, E. Lebenthal, H.A. Reber, and G.A. Scheele, eds. (New York: Raven Press), pp. 301-350.
- Chalfant, M.L., Denton, J.S., Berdiev, B.K., Ismailov, I.I., Benos, D.J., and Stanton, B.A. (1999). Intracellular H^+ regulates the α -subunit of ENaC, the epithelial Na^+ channel. *Am.J.Physiol.Cell Physiol.* 276, C477-C486
- Chan, H.C., Cheung, W.T., Leung, P.Y., Wu, L.J., Chew, S.B.C., Ko, W.H., and Wong, P.Y.D. (1996). Purinergic regulation of anion secretion by cystic fibrosis pancreatic duct cells. *Am.J.Physiol.Cell Physiol.* 271, C469-C477
- Chen, T.Y. and Miller, C. (1996). Nonequilibrium gating and voltage dependence of the ClC-0 Cl^- channel. *J.Gen.Physiol.* 108, 237-250.
- Cheung, C.Y., Wang, X.F., and Chan, H.C. (1998). Stimulation of HCO_3^- secretion across cystic fibrosis pancreatic duct cells by extracellular ATP. *Biological Signals and Receptors* 7, 321-327.
- Cheung, M. and Akabas, M.H. (1997). Locating the anion-selectivity filter of the cystic fibrosis transmembrane conductance regulator (CFTR) chloride channel. *J.Gen.Physiol.* 109, 289-299.
- Chiamvimonvat, N., Perez-Garcia, M.T., Tomaselli, G.F., and Marban, E. (1996). Control of ion flux and selectivity by negatively charged residues in the outer mouth of rat sodium channels. *J.Physiol.(Lond.)* 491, 51-59.
- Chinet, T.C., Fullton, J.M., Yankaskas, J.R., Boucher, R.C., Stutts, and MJ (1994). Mechanism of sodium hyperabsorption in cultured cystic fibrosis nasal epithelium: a patch-clamp study. *American Journal of Physiology* 266, C1061-C1068
- Clarke, L.L., Chinet, T., and Boucher R.C. (1997). Exrtacellular ATP stimulates K^+ secretion across cultured human airway epithelium. *Am.J.Physiol.* 272, L1084-L1091
- Clementi, E. and Meldolesi, J. (1997). The cross-talk between nitric oxide and Ca^{2+} : A story with a complex past and a promising future. *TiPS* 18, 266-269.
- Coakley, W.T. and Gallez, D. (1989). Membrane-membrane contact: involvement of interfacial instability in the generation of discrete contacts. *Biosci.Rep.* 9, 675-691.

- Cotton, C.U. (1998). Ion transport properties of cultured bovine pancreatic duct epithelial cells. *Pancreas* 17, 247-255.
- Cotton, C.U. and Al-Nakkash, L. (1997). Isolation and culture of bovine pancreatic duct epithelial cells. *Am.J.Physiol.Gastrointest Liver Physiol.* 272, G1328-G1337
- Cukierman, S. (1991). Asymmetric electrostatic effects on the gating of rat brain sodium channels in planar lipid membranes. *Biophys.J.* 60, 845-855.
- Dagorn, J.C. (1997). Acute phase reaction of the exocrine pancreas. [Review] [4 refs]. *Digestion* 58 *Suppl* 1, 50-52.
- Devidas, S. and Guggino, W.B. (1997). The cystic fibrosis transmembrane conductance regulator and ATP. *Curr.Opin.Cell Biol.* 9, 547-552.
- Dhermy D., Simeon J., Wautier M-P., Boivin P., and Wautier J-L. (1987). Role of Membrane Sialic Acid Content in the Adhesiveness of Aged Erythrocytes to Human Cultured Endothelial Cells. *Biochem.Biophys.Acta* 904, 201-206.(Abstract)
- di Sant'Agnese, P.A., Darling, R.C., Perera, G.A., and Shea, E. (1953). Sweat electrolyte disturbances associated with childhood pancreatic disease. *Am.J.Med.* 15, 777-784.
- Distler, M., Biel, M., Flockerzi, V., and Hofmann, F. (1994). Expression of cyclic nucleotide-gated cation channels in non-sensory tissues and cells. *Neuropharmacology* 33, 1275-1282.
- Dodge, J.A. (1998). Paediatric and hereditary aspects of chronic pancreatitis. *Digestion* *Suppl.* 4, 49-59.
- Dosanjh, A., Lencer, W., Brown, D., Ausiello, D.A., and Stow, J. (1994a). Heterologous expression of delta F508 CFTR results in decreased sialylation of membrane glycoconjugates. *Am.J.Physiol.* 266, C360-C366
- Dosanjh, A., Lencer, W., Brown, D., Ausiello, D.A., and Stow, J.L. (1994b). Heterologous expression of delta F508 CFTR results in decreased sialylation of membrane glycoconjugates. *American Journal of Physiology* 266, C360-C366
- Durie, P.R. (1997). Inherited causes of exocrine pancreatic dysfunction. *Canadian Journal of Gastroenterology* 11, 145-152.
- Eguiguren, A.L., Rios, J., Riveros, N., Sepulveda, F.V., and Stutzin (1996). Calcium-activated chloride currents and non-selective cation channels in a novel cystic fibrosis-derived human pancreatic duct cell line. *Biochemical & Biophysical Research Communications* 225, 505-513.

- Engelhardt, J.F., Yankaskas, J.R., Ernst, S.A., Yang, Y., Marino, CR, Boucher, R.C., Cohn, J.A., and Wilson, J.M. (1992). Submucosal glands are the predominant site of CFTR expression in the human bronchus. *Nature Genetics* 2, 240-248.
- Evans, R.L., Ashton, N., Elliott, A.C., Green, R., and Argent, B.E. (1996). Interactions between secretin and acetylcholine in the regulation of fluid secretion by isolated rat pancreatic ducts. *J.Physiol.(Lond.)* 496, 265-273.
- Feelisch, M. (1998). The use of nitric oxide donors in pharmacological studies. *Naunyn-Schmiedebergs Archives of Pharmacology* 358, 113-122.
- Fermini, B. and Nathan, R.D. (1990). Sialic acid and the surface charge associated with hyperpolarization-activated, inward rectifying channels. *J.Membr.Biol.* 114, 61-69.
- Finkbeiner, W.E., Shen, B.-Q., and Widdicombe, J.H. (1994). Chloride secretion and function of serous and mucous cells of human airway glands. *Am.J.Physiol.Lung Cell.Mol.Physiol.* 267, L206-L210
- Fisher, S.E., van, B.I., Lloyd, S.E., Pearce, S.H., Thakker, R.V., and Craig, I.W. (1995). Cloning and characterization of CLCN5, the human kidney chloride channel gene implicated in Dent disease (an X-linked hereditary nephrolithiasis). *Genomics* 29, 598-606.
- Forstner, G.G., Vesely, S.M., and Durie, P.R. (1989). Selective precipitation of 14 kDa stone/thread proteins by concentration of pancreaticobiliary secretions: relevance to pancreatic ductal obstruction, pancreatic failure, and CF. *Journal of Pediatric Gastroenterology & Nutrition* 8, 313-320.
- Foskett, J.K. (1998). CIC and CFTR chloride channel gating. *Annual Review of Physiology* 60, 689-717.
- Franck, H., Storr, M., Puschmann, A., Schusdziarra, V., and Allescher, H.-D. (1998). Involvement of intracellular Ca²⁺ stores in inhibitory effects of NO donor SIN-1 and cGMP. *Am.J.Physiol.Gastrointest.Liver Physiol.* 275, G159-G168
- Frase, L.L., Strickland, A.D., Kachel, G.W., and Krejs, G.J. (1985). Enhanced glucose absorption in the jejunum of patients with cystic fibrosis. *Gastroenterology* 88, 478-484.
- Frederiksen, B., Lanng, S., Koch, C., and Hoiby, N. (1996). Improved survival in the Danish center-treated cystic fibrosis patients: results of aggressive treatment. *Pediatr.Pulmonol.* 21, 153-158.
- Freeman, B. (1994). Free radical chemistry of nitric oxide. Looking at the dark side. *Chest* 105, 79S-84S.

- Fritsch, J. and Edelman, A. (1996). Modulation of the hyperpolarization-activated Cl-current in human intestinal T84 epithelial cells by phosphorylation. *J.Physiol.(Lond.)* 490, 115-128.
- Frizzell, R.A., Field, M., and Schultz, S.G. (1979). Sodium-coupled chloride transport by epithelial tissues. *American Journal of Physiology* 236, F1-F8
- Fuller, C.M. and Benos, D.J. (1992). CFTR:. *American Journal of Physiology* 263, C267-C286
- Gabriel, S.E. and Boucher, R.C. (1997). Ion Channels. In *The Lung: Scientific Foundations*. R.G. Crystal and J.B. West, eds. (Philadelphia: Lippencott-Raven), pp. 305-318.
- Gabriel, S.E., Brigman, K.N., Koller, B.H., Boucher, R.C., Stutts, and MJ (1994). Cystic fibrosis heterozygote resistance to cholera toxin in the cystic fibrosis mouse model. *Science* 266, 107-109.
- Galiotta, L.J.V., Zegarra-Moran, O., Mastrocola, T., Wohrle, C., Rugolo, M., and Romeo, G. (1997). Activation of Ca²⁺-dependent K⁺ and Cl⁻ currents by UTP and ATP in CFPAC-1 cells. *Eur.J.Physiol.* 426, 534-541.
- Gandhi, R., Elble, R.C., Gruber, A.D., Schreur, K.D., Ji, H.-L., Fuller, C.M., and Pauli, B.U. (1998). Molecular and functional characterization of a calcium-sensitive chloride channel from mouse lung. *J.Biol.Chem.* 273, 32096-32101.
- Gimenez-Gallego, G., Navia, M.A., Reuben, J.P., Katz, G.M., Kaczorowski, G.J., and Garcia, M.L. (1988). Purification, sequence, and model structure of charybdotoxin, a potent selective inhibitor of calcium-activated potassium channels. *Proc.Natl.Acad.Sci.USA* 85, 3329-3333.
- Graham, J.M. (1993). The identification of subcellular fractions from mammalian cells. *Isolation and Analysis*. J.M. Graham and J.A. Higgins, eds. (Totowa, N.J.: Humana Press Inc.).
- Gray, M.A. and Argent, B.E. (1990a). Non-selective cation channel on pancreatic duct cells. *Biochimica et Biophysica Acta* 1029, 33-42.
- Gray, M.A., Greenwell, J.R., Garton, A.J., and Argent, B.E. (1990b). Regulation of maxi-K⁺ channels on pancreatic duct cells by cyclic AMP-dependent phosphorylation. *J.Membr.Biol.* 115, 203-215.
- Gray, M.A., Winpenny, J.P., Verdon, B., McAlroy, H., and Argent, B.E. (1995). Chloride channels and cystic fibrosis of the pancreas. *Biosci.Rep.* 15, 531-541.
- Green, W.N. and Anderson, O.S. (1991). Surface Charge and Ion Channel Function. *Annu.Rev.Physiol.* 53, 341-359.

- Greger, R. (1996a). The membrane transporters regulating epithelial NaCl secretion. *Pflugers Arch.* 432, 579-588.
- Greger, R., Mall, M., Bleich, M., Ecke, D., Warth, R., Riedemann, N., and Kunzelmann, K. (1996b). Regulation of epithelial ion channels the cystic fibrosis transmembrane conductance regulator. *J.Mol.Med.* 74 , 527-534.
- Grisham, M.B., Jour'd'heuil, D., and Wink, D.A. (1999). Nitric Oxide. I. Physiological chemistry of nitric oxide and its metabolites: implications in inflammation. *Am.J.Physiol.Gastrointest.Liver Physiol.* 276, G315-G321
- Groppi, A., Coutelle, C., Fleury, B., Iron, A., Begueret, J., and Couzigou, P. (1991). Glutathione S-transferase class mu in French alcoholic cirrhotic patients. *Human Genetics* 87, 628-630.
- Grubb, B.R. (1997). Ion Transport Across the Murine Intestine in the Absence and Presence of CFTR. *Comp.Biochem.Physiol.[A]* 118A, 277-282.
- Grunder, S., Thiemann, A., Pusch, M., and Jentsch, T.J. (1992). Regions involved in the opening of CIC-2 chloride channel by voltage and cell volume. *Nature* 360, 759-762.
- Grygorczyk, R., Tabcharani, J.A., and Hanrahan, J.W. (1996). CFTR channels expressed in CHO cells do not have detectable ATP conductance. *J.Membr.Biol.* 151, 139-148.
- Gunderson, K.L. and Kopito, R.R. (1995). Conformational states of CFTR associated with channel gating: the role ATP binding and hydrolysis. *Cell* 82, 231-239.
- Guo, Y., DuVall, M., Crow, J.P., and Matalon, S. (1998). Nitric oxide inhibits Na⁺ absorption across cultured alveolar type II monolayers. *Am.J.Physiol.Lung Cell.Mol.Physiol.* 274 , L369-L377
- Halliwell, B. and Gutteridge, J.M.C. (1989). Lipid Peroxidation: a radical chain reaction. In *Free Radicals in Biology and Medicine*. Anonymous (Oxford Clarendon Press), pp. 188-219.
- Hanrahan, J.W., Kone, Z., Mathews, C.J., Luo, J., Jia, Y.L., and Lindsell, P. (1998). Patch-clamp studies of cystic fibrosis transmembrane conductance regulator chloride channel. *Methods Enzymol.* 293, 169-194.
- Harper, J.F. and Brooker, G.J. (1975). Femtomole sensitive radioimmunoassay for cyclic AMP and cyclic GMP after 2'-O acetylation by acetic anhydride in aqueous solution. *J.Cyclic Nucleotide Res.* 1, 207-218.
- He, Z., Raman, S., Guo, Y., and Reenstra, W.W. (1998). Cystic fibrosis transmembrane conductance regulator activation by cAMP-independent mechanisms. *American Journal of Physiology* 275, C958-C966

- Hechenberger, M., Schwappach, B., Fischer, W.N., Frommer, W.B., Jentsch, T.J., and Steinmeyer, K. (1996). A family of putative chloride channels from *Arabidopsis* and functional complementation of a yeast strain with a *CLC* gene disruption. *J.Biol.Chem.* 271, 33632-33638.
- Hille, B. (1992a). Elementary properties of ions in solution. In *Ion channels of excitable membranes*. Anonymous Sunderland, Mass.: Sinauer Associates), pp. 261-290.
- Hille, B. (1992b). Potassium channels and chloride channels. In *Ion channels of excitable membranes*. Anonymous Sunderland, Mass.: Sinauer Associates), pp. 115-139.
- Hille, B., Woodhull, A.M., and Shapiro, B.I. (1975). Negative Surface charge Near the Sodium Channels of Nerve: Divalent Ions, Monovalent Ions and pH. *Philos.Trans.R.Soc.London Ser. B* 270, 301-318.
- Hirschberg, C.B. (1997). Transporters of nucleotide sugars, nucleotide sulfate and ATP in the Golgi apparatus membrane: Where next? *Glycobiology* 7, 169-171.
- Hirschberg, C.B. and Snider, M.D. (1987). Topography of glycosylation in the rough endoplasmic reticulum and Golgi apparatus. *Annual Review of Biochemistry* 56, 63-87.
- Ho, M.W., Shears, S.B., Bruzik, K.S., Duszyk, M., and French, A.S. (1997). Ins(3,4,5,6)P₄ specifically inhibits a receptor-mediated Ca²⁺-dependent Cl⁻ current in CFPAC-1 cells. *American Journal of Physiology* 272, C1160-C1168
- Hobbs, A.J. (1997). Soluble guanylate cyclase: the forgotten sibling. *TiPS* 18, 484-491.
- Hoover, R.L., Briggs, R.T., and Karnovsky, M.J. (1978). The adhesive interaction between polymorphonuclear leukocytes and endothelial cells in vitro. *Cell* 14, 423-428.
- Hopfer, U., Jacobberger, J.W., Gruenert, D.C., Eckert, R.L., Jat, P.S., and Whitsett, J.A. (1996). Immortalization of epithelial cells. *Am.J.Physiol.Cell Physiol.* 270, C1-C11.
- Houslay, M.D. and Milligan, G. (1997). Tailoring cAMP-signalling responses through isoform multiplicity. *TIBS* 22, 217-224.
- Hull, J. and Thomson, A.H. (1998). Contribution of genetic factors other than CFTR to disease severity in cystic fibrosis. *Thorax* 53, 1018-1021.
- Hwang, T.H., Schwiebert, E.M., and Guggino, W.B. (1996). Apical and basolateral ATP stimulates tracheal epithelial chloride secretion via multiple purinergic receptors. *Am.J.Physiol.Cell Physiol.* 270, C1611-C1623.

- Ichimori, K., Ishida, H., Fukahori, M., Nakazawa, H., and Murahami, E. (1994). Practical nitric oxide measurement employing a nitric oxide-selective electrode. *Rev.Sci.Instrum* 65, 1-5.
- Inoue, C.N., Wco, J.S., Schwiebert, E.M., Morita, T., Hanaoka, K., Guggino, S.E., and Guggino, W.B. (1997). Role of purinergic receptors in chloride secretion in Caco-2 cells. *Am.J.Physiol.* 272, C1862-C1870.
- Ischiropoulos, H., Zhu, L., and Beckman, J.S. (1992). Peroxynitrite formation from macrophage-derived nitric oxide. *Archives of Biochemistry & Biophysics* 298, 446-451.
- J.Barasch and Q.Al-Awqati (1992). Chloride channels, Golgi pH and cystic fibrosis. *Trends Cell Biol.* 2, 35-37.
- Jaffe, A., Bush, A., Geddes, D.M., and Alton, E.W.F.W. (1999). Prospects for gene therapy in cystic fibrosis. *Arch.Dis.Child.* 80, 286-289.
- Jain, L., Chen, X.-J., Brown, L.A., and Eaton, D.C. (1998). Nitric oxide inhibits lung sodium transport through a cGMP-mediated inhibition of epithelial cation channels. *Am.J.Physiol.Lung Cell.Mol.Physiol.* 274, L475-L484.
- James, W. and Agnew, W. (1987). Multiple Oligosaccharide Chains in the Voltage-Sensitive Na channel From *Electrophorus electricus*: evidence for alpha-2,8-linked polysialic acid. *Biochem.Biophys.Res.Commun.* 148, 817-826.
- Jentsch, T.J. and Günther, W. (1997). Chloride channels: An emerging molecular picture. *BioEssays* 19, 117-126.
- Ji, H.-L., Fuller, C.M., and Benos, D.J. (1998). Osmotic pressure regulates $\alpha\beta\gamma$ -rENaC expressed in *Xenopus* oocytes. *Am.J.Physiol.Cell Physiol.* 275, C1182-C1190.
- Jia, Y.L., Mathews, C.J., and Hanrahan, J.W. (1997). Phosphorylation by protein kinase C is required for acute activation of cystic fibrosis transmembrane conductance regulator by protein kinase A. *J.Biol.Chem.* 272, 4978-4984.
- Jiang, C., Fang, S.L., Xiao, Y.F., O'Connor, S.P., Nadler, S.G., Lee, D.W., Jefferson, DM, Kaplan, J.M., Smith, A.E., and Cheng, S.H. (1998). Partial restoration of cAMP-stimulated CFTR chloride channel activity in DeltaF508 cells by deoxyspergualin. *American Journal of Physiology* 275, C171-C178.
- Jiang, C., Finkbeiner, W.E., Widdicombe, J.H., and Miller, S.S. (1997). Fluid transport across cultures of human tracheal glands is altered in cystic fibrosis. *J.Physiol.(Lond.)* 501, 637-647.
- Jones, M.N. (1975). The Electrical Double Layer. In *Biological Interfaces: An introduction to the surface and colloid science of biochemical and biological*

- systems. Anonymous Oxford: Elsevier Scientific Publishing Company), pp. 135-161.
- Jordt, S.E. and Jentsch, T.J. (1997). Molecular dissection of gating in the CIC-2 chloride channel. *EMBO J.* *16*, 1582-1592.
- Joris, L., Dab, I., and Quinton, P.M. (1993). Elemental composition of human airway surface fluid in healthy and diseased airways. *American Review of Respiratory Disease* *148*, 1633-1637.
- Jovov, B., Ismailov, I.I., Berdiev, B.K., Fuller, C.M., Sorscher, E.J., Dedman, J.R., Kaetzel, M.A., and Benos, D.J. (1995). Interaction between CFTR and Outwardly rectified chloride channels. *J.Biol.Chem.* *270*, 29194-29200.
- Kachintorn, U., Vajanaphanich, M., Traynor-Kaplan, A.E., Dharmasathaphorn, K., and Barrett, K.E. (1997). Activation by calcium alone of chloride secretion in T84 epithelial cells. *Br.J.Pharmacol.* *109*, 510-517.
- Kamosinska, B., Radomski, M.W., Duszyk, M., Radomski, A., and Man, S.F.P. (1997). Nitric oxide activates chloride currents in human lung epithelial cells. *Am.J.Physiol.* *272*, L1098-L1104.
- Katayama Takeshi, Takai Ken-Ichi, Kariyama Reiko, and Kanemasa Yasuiro (1978). Colloid Titration of Heparin Using Cat-Floc (Polydiallyldimethyl Ammonium Chloride) as Standard Polycation. *Anal.Biochem.* *88*, 382-387.
- Keller, J.N., Hanni, K.B., Mattson, M.P., and Markesbery, W.R. (1998). Cyclic nucleotides attenuate lipid peroxidation-mediated neuron toxicity. *Neuroreport* *9*, 3731-3734.
- Kelley, T.J., Cotton, C.U., and Drumm, M.L. (1998a). Regulation of amiloride-sensitive sodium absorption in murine airway epithelium by C-type natriuretic peptide. *American Journal of Physiology* *274*, L990-L996.
- Kelley, T.J. and Drumm, M.L. (1998b). Inducible nitric oxide synthase expression is reduced in cystic fibrosis murine and human airway epithelial cells. *J.Clin.Invest.* *102*, 1200-1207.
- Kelm, S. and Schauer, R. (1997). Sialic acids in molecular and cellular interactions. *International Review of Cytology* *175*, 137-240.
- King, M., Dasgupta, B., Tomkiewicz, R.P., and Brown, N.E. (1997). Rheology of cystic fibrosis sputum after in vitro treatment with hypertonic saline alone and in combination with recombinant human deoxyribonuclease I. *American Journal of Respiratory & Critical Care Medicine* *156*, 173-177.

- Knowles, M.R., Clarke, L.L., and Boucher, R.C. (1991). Activation by extracellular nucleotides of chloride secretion in the airway epithelia of patients with cystic fibrosis. *New England Journal of Medicine* 325, 533-538.
- Koivisto, A. and Nedergaard, J. (1995). Modulation of calcium-activated non-selective cation channel activity by nitric oxide in rat brown adipose tissue. *J.Physiol.(Lond.)* 486, 59-65.
- Konstan, M.W. and Berger, M. (1997). Current understanding of the inflammatory process in cystic fibrosis: Onset and etiology. *Pediatr.Pulmonol.* 24, 137-142.
- Kosari, F., Sheng, S., Li, J., Mak, D.-O.D., Foskett, J.K., and Kleyman, T.R. (1998). Subunit stoichiometry of the epithelial sodium channel. *J.Biol.Chem.* 273, 13469-13474.
- Koscielak, J. (1995). Diseases of aberrant glycosylation. *Acta Biochimica Polonica* 42, 1-10.
- Kourie, J.I. (1998). Interaction of reactive oxygen species with ion transport mechanisms. *Am.J.Physiol.Cell Physiol.* 275, C1-C24.
- Krippet-Drews, P., Kröncke, K.-D., Welker, S., Zemple, G., Roenfeldt, M., Ammon, H.P.T., Lang, F., and Drews, G. (1995). The effects of nitric oxide on the membrane potential and ionic currents of mouse pancreatic B cells. *Endocrinology* 136, 5363-5369.
- Kunzelmann, K., Kiser, G.L., Schreiber, R., and Riordan, J.R. (1997). Inhibition of epithelial Na⁺ currents by intracellular domains of the cystic fibrosis transmembrane conductance regulator. *FEBS Lett.* 400, 341-344.
- Lang, A.B., Schaad, U.B., Rudeberg, A., Wedgwood, J., Que, J.U., Furer, E., and Cryz, S.J., Jr. (1995). Effect of high-affinity anti-Pseudomonas aeruginosa lipopolysaccharide antibodies induced by immunization on the rate of Pseudomonas aeruginosa infection in patients with cystic fibrosis. *J.Pediatr.* 127, 711-717.
- Latorre, R., Labarca, P., and Naranjo, D. (1992). Surface charge effects on ion conduction in ion channels. *Methods Enzymol.* 207, 471-501.
- Le, B.L., Bignon, J.D., Raguene, O., Mercier, B., Georgelin, Schnee, M., Soulard, F., Gagne, K., Bonneville, F., Muller, J.Y., Bachner, L., and Ferec, C. (1996). The hereditary pancreatitis gene maps to long arm of chromosome 7. *Hum.Mol.Genet.* 5, 549-554.
- Lee, H.C. (1994). A signaling pathway involving cyclic ADP-ribose, cGMP and nitric oxide. *NIPS* 9, 134-137.

- Lee, M.G., Wigley, W.C., Zeng, W., Noel, L.E., Marino, C.R., Thomas, P.J., and Muallem, S. (1999). Regulation of $\text{Cl}^-/\text{HCO}_3^-$ exchange by cystic fibrosis transmembrane conductance regulator expressed in NIH 3T3 and HEK 293 cells. *J.Biol.Chem.* 274, 3414-3421.
- Li, C., Ramjeesingh, M., and Bear, C.E. (1996). Purified cystic fibrosis transmembrane conductance regulator (CFTR) does not function as an ATP channel. *J.Biol.Chem.* 271, 11623-11626.
- Lincoln, T.M. and Cornwell, T.L. (1993). Intracellular cyclic GMP receptor proteins. *FASEB* 7, 328-338.
- Lincoln, T.M., Cornwell, T.L., Komalavilas, P., and Boerth, N. (1996). Cyclic GMP-dependent protein kinase in nitric oxide signaling. *Methods Enzymol.* 269, 149-166.
- Lindsell, P. and Hanrahan, J.W. (1998). Glutathione permeability of CFTR. *Am.J.Physiol.Cell Physiol.* 275, C323-C326.
- Lindsell, P., Tabcharani, J.A., Rommens, J.M., Hou, Y.-X., Chang, X.-B., Tsui, L.C., Riordan, J.R., and Hanrahan, J.W. (1997). Permeability of wild-type and mutant CFTR chloride channels to polyatomic anions. *J.Gen.Physiol.* 110, 355-364.
- Lohmann, S.M., Vaandrager, A.B., Smolenski, A., Walter, U., De, and Jonge, H.R. (1997). Distinct and specific functions of cGMP-dependent protein kinases. *Trends in Biochemical Sciences* 22, 307-312.
- Loussouarn, G., Demolombe, S., Mohammad-Panah, R., Escande, D., and Baro, I. (1996). Expression of CFTR controls cAMP-dependent activation of epithelial K^+ currents. *Am.J.Physiol.Cell Physiol.* 271, C1565-C1573.
- Lu, M. and Wang, W.-H. (1996). Nitric oxide regulates the low-conductance K^+ channel in basolateral membrane of cortical collecting duct. *Am.J.Physiol.Cell Physiol.* 270, C1336-C1342.
- Lu, M. and Wang, W.-H. (1998). Reaction of nitric oxide with superoxide inhibits basolateral K^+ channels in the rat CCD. *Am.J.Physiol.Cell Physiol.* 275, C309-C316.
- Lundbaek, J.A., Maer, A.M., and Andersen, O.S. (1997). Lipid bilayer electrostatic energy, curvature stress, and assembly of gramicidin channels. *Biochemistry* 36, 5695-5701.
- Luo, J., Pato, M.D., Riordan, J.R., and Hanrahan, J.W. (1998). Differential regulation of single CFTR channels by PP2C, PP2A, and other phosphatases. *Am.J.Physiol.Cell Physiol.* 274, C1397-C1410.

- Lyons, C.R. (1995). The role of nitric oxide in inflammation. *Advances in Immunology* 60, 323-371.
- Ma, J., Zhao, J., Drumm, M.L., Xie, J., and Davis, P.B. (1997). Function of the R domain in the cystic fibrosis transmembrane conductance regulator chloride channel. *J.Biol.Chem.* 272, 28133-28141.
- MacKinnon, R., Latorre, R., and Miller, C. (1989). Role of surface electrostatics in the operation of a high-conductance Ca^{2+} -activated K^+ channel. *Biochemistry* 28, 8092-8099.
- Madden, M.E. and Sarras, M.P. (1988). Morphological and biochemical characterization of a human pancreatic ductal cell line (PANC-1). *Pancreas* 3, 512-528.
- Malinski, T., Bailey, F., Zhang, Z.G., and Chopp, M. (1993). Nitric oxide measured by a porphyrinic microsensor in rat brain after transient middle cerebral artery occlusion. *Journal of Cerebral Blood Flow & Metabolism* 13, 355-358.
- Mall, M., Hipper, A., Greger, R., and Kunzelmann, K. (1996). Wild type but not deltaF508 CFTR inhibits Na^+ conductance when coexpressed in *Xenopus* oocytes. *FEBS Lett.* 381, 47-52.
- Mandel, K.G., McRoberts, J.A., Beuerlein, G., Foster, E.S., and Dharmasathaphorn, K. (1986). Ba^{2+} inhibition of VIP- and A23187-stimulated Cl^- secretion by T84 cell monolayers. *Am.J.Physiol.Cell Physiol.* 250, C486-C494.
- March, T.H., Jeffery, E.H., and Wallig, M.A. (1998). Characterization of rat pancreatic glutathione S-transferases by chromatofocusing, reverse-phase high-performance liquid chromatography, and immunohistochemistry. *Pancreas* 17, 217-228.
- Martin, S.C. and Shuttleworth, T.J. (1996). The control of fluid-secreting epithelia by VIP. *Annals of the New York Academy of Sciences* 805, 133-147.
- Mathias, N.R., Yamashita, F., and Lee, V.H.L. (1996). Respiratory epithelial cell culture models for evaluation of ion and drug transport. *Adv Drug Deliv Rev.* 22, 215-249.
- Matsui, H., Grubb, B.R., Tarran, R., Randell, S.H., Gatzky, J.T., Davis, C.W., and Boucher, R.C. (1998a). Evidence for periciliary liquid layer depletion, not abnormal ion composition, in the pathogenesis of cystic fibrosis airways disease. *Cell* 95, 1005-1015.
- Matsui, H., Randell, S.H., Peretti, S.W., Davis, C.W., and Boucher, R.C. (1998b). Coordinated clearance of periciliary liquid and mucus from airway surfaces. *J.Clin.Invest.* 102, 1125-1131.

- Mayer, B. and Andrew, P. (1998). Nitric oxide synthases: catalytic function and progress towards selective inhibition. *Naunyn-Schmiedeberg's Arch.Pharmacol.* 358, 127-133.
- McCann, J.D. and Welsh, M.J. (1990). Regulation of Cl⁻ and K⁺ channels in airway epithelium. *Annu.Rev.Physiol.* 52, 115-135.
- McCloy, R. (1998). Chronic pancreatitis at Manchester, UK: Focus on antioxidant therapy. *Digestion Suppl.* 4, 36-48.
- McCray PB Jr and Bentley, L. (1997). Human airway epithelia express a beta-defensin. *American Journal of Respiratory Cell & Molecular Biology* 16, 343-349.
- McDonagh, J.C. and Nathan, R.D. (1990). Sialic acid and the surface charge of delayed rectifier potassium channels. *Journal of Molecular & Cellular Cardiology* 22, 1305-1316.
- McDonough, A.A. (1998). Can ENaC regulate ICF as well as ECF volume? Focus on "Osmotic pressure regulates $\alpha\beta\gamma$ -rENaC expressed in *Xenopus* oocytes". *Am.J.Physiol.Cell Physiol.* 275, C1179-C1181.
- McKendrick, J.D., Salas, E., Dubé, G.P., Murat, J., Russell, J.C., and Radomski, M.W. (1998). Inhibition of nitric oxide generation unmasks vascular dysfunction in insulin-resistant, obese JCR:LA-*cp* rats. *Br.J.Pharmacol.* 124, 361-369.
- Milbourne, E.A. and Bygrave, F.L. (1995). Do nitric oxide and cGMP play a role in calcium cycling? *Cell Calcium* 18, 207-213.
- Molero, X., Guarner, F., Salas, A., Mourelle, M., Puig, V., and Malagelada, J.R. (1995). Nitric oxide modulates pancreatic basal secretion and response to cerulein in the rat: effects in acute pancreatitis. *Gastroenterology* 108, 1855-1862.
- Mulberg, A.E., Tulk, B.M., and Forgac, M. (1991). Modulation of coated vesicle chloride channel activity and acidification by reversible protein kinase A-dependent phosphorylation. *J.Biol.Chem.* 266, 20590-20593.
- Nagao, P.E., Silva, G.C.E., Benchetrit, L.C., and Barrucand, L. (1995). Cell surface hydrophobicity and the net electric surface charge of group B streptococci: The role played in the micro-organism-host cell interaction. *Microbios* 82, 207-216.
- Neuschwander-Tetri, B.A., Presti, M.E., and Wells, L.D. (1997). Glutathione synthesis in the exocrine pancreas. *Pancreas* 14, 342-349.
- Nguyen, T.D. and Moody, M.W. (1998a). Calcium-activated potassium conductances on cultured nontransformed dog pancreatic duct epithelial cells. *Pancreas* 17, 348-358.

- Nguyen, T.D., Moody, M.W., Savard, C.E., and Lee, S.P. (1998b). Secretory effects of ATP on nontransformed dog pancreatic duct epithelial cells. *Am.J.Physiol.Gastrointest.Liver Physiol.* 275, G104-G113
- Nilius, B., Eggermont, J., Voets, T., and Droogmans, G. (1996). Volume-activated Cl⁻ channels. *General Pharmacology* 27, 1131-1140.
- Nir, S. and Andersen, M. (1977). Van der Waals interactions between cell surfaces. *J.Membr.Biol.* 31, 1-18.
- Nishiguchi, E., Okubo, K., and Nakamura, S. (1998). Adhesion of human red blood cells and surface charge of the membrane. *Cell Structure & Function* 23, 143-152.
- Novak, I. and Greger, R. (1988). Electrophysiological study of transport systems in isolated perfused pancreatic ducts: properties of the basolateral membrane. *Pflugers Archiv - European Journal of Physiology* 411, 58-68.
- O'Loughlin, E.V., Hunt, D.M., Bostrom, T.E., Hunter, D., Gaskin, K.J., Gyory, A., and Cockayne, D.J. (1996). X-ray microanalysis of cell elements in normal and cystic fibrosis jejunum: evidence for chloride secretion in villi. *Gastroenterology* 110, 411-418.
- Ohyashiki, T., Adachi, R., and Matsui, K. (1993). Effects of lipid peroxidation on surface charge density of the porcine intestinal brush-border membranes. *Biological & Pharmaceutical Bulletin* 16, 17-21.
- Ohyashiki, T., Takino, T., and Matsui, K. (1994). Inhibition of Ca²⁺-induced aggregation of porcine intestinal brush-border membranes by lipid peroxidation. *Journal of Biochemistry* 116, 351-356.
- Oppenheimer, E.H. and Esterly, J.R. (1975). Pathology of cystic fibrosis review of the literature and comparison with 146 autopsied cases. *Perspectives in Pediatric Pathology* 2, 241-278.
- Palmer, R.M.J., Ferrige, A.G., and Moncada, S. (1987). Nitric Oxide release accounts for the biological activity of endothelium-derived relaxing factor. *Nature* 327, 524-526.
- Pasyk, E.A. and Foskett, J.K. (1995). Mutant (Δ F508) Cystic Fibrosis Transmembrane Conductance Regulator Cl⁻ Channel is Functional When Retained in Endoplasmic Reticulum of Mammalian Cells. *J.Biol.Chem.* 271, 12347-12350.
- Pei, Z.-M., Ward, J.M., Harper, J.F., and Schroeder, J.I. (1996). A novel chloride channel in *Vicia faba* guard cell vacuoles activated by the serine/threonine kinase, CDPK. *EMBO J.* 15, 6564-6574.
- Perozo, E. and Bezanilla, F. (1990). Phosphorylation affects voltage gating of the delayed rectifier K⁺ channel by electrostatic interactions. *Neuron* 5, 685-690.

- Pier, G.B., Grout, M., and Zaidi, T.S. (1997). Cystic fibrosis transmembrane conductance regulator is an epithelial cell receptor for clearance of *Pseudomonas aeruginosa* from the lung. *Proc.Natl.Acad.Sci.USA* 94, 12088-12093.
- Pilewski, J.M. and Frizzell, R.A. (1999). Role of CFTR in airway disease. *Physiological Reviews* 79, S215-S255
- Ponting, C.P. (1997). CBS domains in ClC chloride channels implicated in myotonia and nephrolithiasis (kidney stones). *J.Mol.Med.* 75, 160-163.
- Portal, B.C., Richard, M.-J., Faure, H.S., Hadjian, A.J., and Favier, A.E. (1995). Altered antioxidant status and increased lipid peroxidation in children with cystic fibrosis. *Am.J.Clin.Nutr.* 61, 843-847.
- Press, W.H., Flannery, B.P., Teukolsky, S.A., and Vetterling, W.T. (1990). Modeling of Data. In *Numerical recipes in C: The art of scientific computing*. AnonymousCambridge: Cambridge University Press), pp. 517-565.
- Pusch, M. (1996). Commentary - Knocking on channel's door - The permeating chloride ion acts as the gating charge in ClC-0. *J.Gen.Physiol.* 108, 233-236.
- Quinton, P.M. (1983). Chloride impermeability in cystic fibrosis. *Nature* 301, 421-422.
- Quinton, P.M. (1994). Cystic Fibrosis Old Questions: New Answers. The second Joseph Levy memorial lecture, Paris.
- Quinton, P.M. (1999). Physiological basis of cystic fibrosis: a historical perspective. *Physiological Reviews* 79, S3-S22
- Quinton, P.M. and Reddy, M.M. (1993). The Sweat Gland. In *Cystic Fibrosis*. P.B. Davis, ed. (New York: Marcel Dekker, Inc.), pp. 137-159.
- Radomski, M.W. and Salas, E. (1995). Nitric oxide - biological mediator, modulator and factor of injury: It's role in the pathogenesis of atherosclerosis. *Atherosclerosis* 118, S69-S80
- Rae, J., Cooper, K., Gates, P., and Watsky, M. (1991). Low access resistance perforated patch recordings using amphotericin B. *J.Neurosci.Met.* 37, 15-26.
- Ramjeesingh, M., Huan, L.J., Wilschanski, M., Durie, P., Li, C., Gyomorey, K., Wang, Kent, G., Tanswell, K.A., Cutz, E., Ackerley, C., and Bear, C.E. (1998). Assessment of the efficacy of in vivo CFTR protein replacement therapy in CF mice. *Human Gene Therapy* 9, 521-528.
- Ramjeesingh, M., Li, C., Garami, E., Huang, L., Galley, K., Wang, Y., and Bear, C.E. (1999). Walker mutations reveal loose relationship between catalytic and channel-gating activities of purified CFTR. *Biochemistry* 38, 1463-1468.

- Recio-Pinto, E., Thornhill, W.B., Duch, D.S., Levinson, S.R., Urban, and BW (1990). Neuraminidase treatment modifies the function of electroplax sodium channels in planar lipid bilayers. *Neuron* 5, 675-684.
- Reddy, M.M., Kopito, R.R., and Quinton, P.M. (1998). Cytosolic pH regulates GCl through control of phosphorylation states of CFTR. *American Journal of Physiology* 275, C1040-C1047
- Reddy, M.M. and Quinton, P.M. (1996). Hydrolytic and nonhydrolytic interactions in the ATP regulation of CFTR Cl⁻ conductance. *Am.J.Physiol.Cell Physiol.* 271, C35-C42.
- Reddy, M.M. and Quinton, P.M. (1997). Cystic fibrosis affects specific cell type in sweat gland secretory coil. *Am.J.Physiol.* 273, C426-C433.
- Renier, M., Tamanini, A., Nicolis, E., Rolfini, R., Imler, L., Pavirani, A., and Cabrini, G. (1995). Use of a membrane potential-sensitive probe to assess biological expression of the cystic fibrosis transmembrane conductance regulator. *Hum.Gene Ther.* 6, 1275-1283.
- Rieu, P., Porteu, F., Bessou, G., Lesavre, P., and Halbwachs-Mecarelli, L. (1992). Human neutrophils release their major membrane sialoprotein, leukosialin (CD43), during cell activation. *European Journal of Immunology* 22, 3021-3026.
- Rinderknecht, H. (1993). Pancreatic secretory enzymes. In *The Pancreas: biology, pathobiology and disease*. V.L.W. Go, E.P. Dimagno, J.D. Gardner, E. Lebenthal, H.A. Reber, and G.A. Scheele, eds. (New York: Raven Press), pp. 301-350.
- Riviere, M.E., Mysiakine, E., Barot, R., Nobrega, T., Fresneau, C., Tlaskalova-Hogenova, H., Dumitrescu, M., and Arrio, B. (1995). Correlation between membrane potential changes and proliferation of murine peritoneal lymphocytes stimulated by *Nocardia* water soluble mitogen. *Cellular & Molecular Biology* 41, 289-296.
- Roch, B., Baro, I., Hongre, A.-S., and Escande, D. (1995). ATP-sensitive K⁺ channels regulated by intracellular Ca²⁺ and phosphorylation in normal (T84) and cystic fibrosis (CFPAC-1) epithelial cells. *Pflugers Arch.* 426, 355-363.
- Rommens, J.M., Iannuzzi, M.C., Kerem, B., Drumm, M.L., Melmer, G., Dean, M., Rozmahel, R., Cole, J.L., Kennedy, D., and Hidaka, N. (1989). Identification of the cystic fibrosis gene: chromosome walking and jumping. *Science* 245, 1059-1065.
- Rostovtseva, T.K., Aguilera, V.M., Vodyanoy, I., Bezrukov, S.M., and Parsegian, V.A. (1998). Membrane surface-charge titration probed by gramicidin A channel conductance. *Biophys.J.* 75, 1783-1792.

- Roum, J.H., Buhl, R., McElvaney, N.G., Borok, Z., and Crystal, R.G. (1993). Systemic deficiency of glutathione in cystic fibrosis. *Journal of Applied Physiology* 75, 2419-2424.
- Rubbo, H. and Freeman, B.A. (1996). Nitric oxide regulation of lipid oxidation reactions: formation and analysis of nitrogen-containing oxidized lipid derivatives. *Methods Enzymol.* 269, 385-394.
- Rubenstein, R.C., Egan, M.E., and Zeitlin, P.L. (1997). In vitro pharmacologic restoration of CFTR-mediated chloride transport with sodium 4-phenylbutyrate in cystic fibrosis epithelial cells containing delta F508-CFTR. *J.Clin.Invest.* 100, 2457-2465.
- Ruknudin, A., Schulze, D.H., Sullivan, S.K., Lederer, W.J., Welling, and PA (1998). Novel subunit composition of a renal epithelial KATP channel. *J.Biol.Chem.* 273, 14165-14171.
- Sakai, H., Kumano, E., Ikari, A., and Takeguchi, N. (1995). A gastric housekeeping Cl⁻ channel activated via prostaglandin EP₃ receptor-mediated Ca²⁺/Nitric oxide/cGMP pathway. *J.Biol.Chem.* 270, 18781-18785.
- Sansom, S.C., Stockand, J.D., Hall, D., and Williams, B. (1997). Regulation of large calcium-activated potassium channels by protein phosphatase 2A. *J.Biol.Chem.* 272, 9902-9906.
- Sarles, H. (1965). Pancreatitis. Symposium of Marseilles, 1963 *Basel*,
- Sarles, J., Barthellemy, S., Ferec, C., Iovanna, J., Roussey, M., Farriaux, J.-P., Toutain, A., Berthelot, J., Maurin, N., Codet, J.-P., Berthezene, P., and Dagorn, J.C. (1999). Blood concentrations of pancreatitis associated protein in neonates: relevance to neonatal screening for cystic fibrosis. *Arch.Dis.Child.Fetal Neonatal Ed.* 80, F118-F122.
- Sassa, H., Kogure, K., Takaishi, Y., and Terada, H. (1994). Structural basis of potent antiperoxidation activity of the triterpene celastrol in mitochondria: effect of negative membrane surface charge on lipid peroxidation. *Free Radical Biology & Medicine* 17, 201-207.
- Sato, K. and Sato, F. (1984). Defective beta adrenergic response of cystic fibrosis sweat glands in vivo and in vitro. *J.Clin.Invest.* 73, 1763-1771.
- Sato, S., Ward, C.L., Krouse, M.E., Wine, J.J., and Kopito, R.R. (1996). Glycerol reverses the misfolding phenotype of the most common cystic fibrosis mutation. *J.Biol.Chem.* 271, 635-638.
- Scanlin, T.F., Wang, Y.M., and Glick, M.C. (1985). Altered fucosylation of membrane glycoproteins from cystic fibrosis fibroblasts. *Pediatric Research* 19, 368-374.

- Scheele, G.A., Fukuoka, S.I., Kern, H.F., and Freedman, S.D. (1996). Pancreatic dysfunction in cystic fibrosis occurs as a result of impairments in luminal pH, apical trafficking of zymogen granule membranes, and solubilization of secretory enzymes. *Pancreas* 12, 1-9.
- Scheule, R.K., Bagley, R.G., Erickson, A.L., Wang, K.X., Fang, S.L., Vaccaro, C., O'Riordan, C.R., Cheng, S.H., and Smith, A.E. (1995). Delivery of purified, functional CFTR to epithelial cells *in vitro* using influenza hemagglutinin. *Am.J.Respir.Cell Mol.Biol.* 13, 330-343.
- Schmidt, H.H.H.W., Lohmann, S.M., and Walter, U. (1993). The nitric oxide and cGMP signal transduction system: Regulation and mechanism of action. *Biochim.Biophys.Acta* 1178, 153-175.
- Schoumacher, R.A., Ram, J., Ianuzzi, M.C., Bradbury, N.A., Wallace, R.W., Tom Hon, C., Kelly, D.R., Schmid, S.M., Gelder, F.B., Rado, T.A., and Frizzell, R.A. (1990). A cystic fibrosis pancreatic cell line. *Proc.Natl.Acad.Sci.USA* 87, 4012-4016.
- Schreier, H. and Sawyer, S.M. (1996). Liposomal DNA vectors for cystic fibrosis gene therapy. Current applications, limitations, and future directions. *Adv.Drug Deliv.Rev.* 19, 73-87.
- Schwab, U.E., Wold, A.E., Carson, J.L., Leigh, M.W., Cheng, P.W., Gilligan, P.H., and Boat, T.F. (1993). Increased adherence of *Staphylococcus aureus* from cystic fibrosis lungs to airway epithelial cells. *American Review of Respiratory Disease* 148, 365-369.
- Schwappach, B., Stobrawa, S., Hechenberger, M., Steinmeyer, K., and Jentsch, T.J. (1998). Golgi localization and functionally important domains in the NH₂ and COOH terminus of the yeast CLC putative chloride channel Gef1p. *J.Biol.Chem.* 273, 15110-15118.
- Schwiebert, E.M., Flotte, T., Cutting, G.R., and Guggino, W.B. (1994). Both CFTR and outwardly rectifying chloride channels contribute to cAMP-stimulated whole cell chloride currents. *American Journal of Physiology* 266, C1464-C1477.
- Schwiebert, E.M., Morales, M.M., Devidas, S., Egan, M.E., Guggino, W.B. (1998). Chloride channel and chloride conductance regulator domains of CFTR, the cystic fibrosis transmembrane conductance regulator. *Proc.Natl.Acad.Sci.USA* 95, 2674-2679.
- Schwiebert, E.M., Potter, E.D., Hwang, T.H., Woo, J.S., Ding, C., Qiu, W., Guggino, W.B., Levine, M.A., and Guggino, S.E. (1997). cGMP stimulates sodium and chloride currents in rat tracheal airway epithelia. *Am.J.Physiol.Cell Physiol.* 272, C911-C922.

- Sciuto, A.M. (1997). Antioxidant properties of glutathione and its role in tissue protection. In *Oxidants, Antioxidants and Free Radicals*. S.I. Baskin and H. Salem, eds. (Washington, DC: Taylor and Francis), pp. 171-191.
- Seksek, O., Biwersi, J., and Verkman, A.S. (1995). Direct measurement of *trans*-Golgi pH in living cells and regulation by second messengers. *J.Biol.Chem.* *270*, 4967-4970.
- Seksek, O., Biwersi, J., and Verkman, A.S. (1996). Evidence against defective *trans*-Golgi acidification in cystic fibrosis. *J.Biol.Chem.* *271*, 15542-15548.
- Sharer, N., Schwarz, M., Malone, G., Howarth, A., Painter, J., Super, M., and Braganza, J. (1998). Mutations of the cystic fibrosis gene in patients with chronic pancreatitis. *New England Journal of Medicine* *339*, 645-652.
- Sharma, R.K. and Kalra, J. (1994). Molecular interaction between cAMP and calcium in calmodulin-dependent cyclic nucleotide phosphodiesterase system. *Clin.Invest.Med.* *17*, 374-382.
- Sheppard, D.N. and Robinson, K.A. (1997). Mechanism of glibenclamide inhibition of cystic fibrosis transmembrane conductance regulator Cl⁻ channels expressed in a murine cell line. *J.Physiol.(Lond.)* *503*, 333-346.
- Sherry, A.M., Stroffekova, K., Knapp, L.M., Kupert, E.Y., Cuppoletti, J., and Malinowska, D.H. (1997). Characterization of the human pH- and PKA-activated ClC-2G(2 alpha) Cl⁻ channel. *American Journal of Physiology* *273*, C384-C393.
- Shumaker, H., Amlal, H., Frizzell, R.A., Ulrich II, C.D., and Soleimani, M. (1999). CFTR drives Na⁺-nHCO₃⁻ cotransport in pancreatic duct cells: a basis for defective HCO₃⁻ secretion in CF. *Am.J.Physiol.Cell Physiol.* *276*, C16-C25.
- Shyng, S.-L., Ferrigni, T., and Nichols, C.G. (1997). Regulation of K_{ATP} channel by diazoxide and MgADP: Distinct functions of the two nucleotide binding folds of the sulfonylurea receptor. *J.Gen.Physiol.* *110*, 643-654.
- Singh, R.J., Hogg, N., Joseph, J., and Kalyanaraman, B. (1996). Mechanism of nitric oxide release from S-Nitrosothiols. *J.Biol.Chem.* *271*, 18596-18603.
- Singh, S.P., Wishnok, J.S., Keshive, M., Deen, W.M., and Tannenbaum, S.R. (1996). The chemistry of the S-nitrosoglutathione/glutathione system. *Proc.Natl.Acad.Sci.USA* *93*, 14428-14433.
- Slater and Sloan (1975). *Atherosclerosis* *21*, 259-272.
- Smith, A.E. (1995). Treatment of cystic fibrosis based on understanding CFTR. *J.Inherited Metab.Dis.* *18*, 508-516.

- Smith, J.J., Travis, S.M., Greenberg, E.P., and Welsh, M.J. (1996). Cystic fibrosis airway epithelia fail to kill bacteria because of abnormal airway surface fluid. *Cell* 85, 229-236.
- Snouwaert, J.N., Brigman, K.K., Latour, A.M., Malouf, N.N., Boucher, R.C., Smithies, O., and Koller, B.H. (1992). An animal model for cystic fibrosis made by gene targeting. *Science* 257, 1083-1088.
- Sohma, Y., Gray, M.A., Imai, Y., and Argent, B.E. (1996). A mathematical model of the pancreatic ductal epithelium. *J.Membr.Biol.* 154, 53-67.
- Stamler, J.S., Singel, D.J., and Loscalzo, J. (1992). Biochemistry of nitric oxide and its redox-activated forms. *Science* 258, 1898-1902.
- Steagall, W.K., Kelley, T.J., Marsick, R.J., and Drumm, M.L. (1998). Type II protein kinase A regulates CFTR in airway, pancreatic, and intestinal cells. *American Journal of Physiology* 274, C819-C826.
- Steer, M.L. (1993). Etiology and pathophysiology of acute pancreatitis. In *The Pancreas: biology, pathobiology and disease*. V.L.W. Go, E.P. Dimagno, J.D. Gardner, E. Lebenthal, H.A. Reber, and G.A. Scheele, eds. (New York: Raven Press), pp. 301-350.
- Stein, A.A., Porta, E., Powers, S.Jr., Leather, R., Linton, P., and Patterson, P. (1963). Studies on surgical biopsies of pancreas and liver in four cases of cystic fibrosis: Morphologic and histochemical. *Annals of Surger* 157, 516-524.
- Stern, M. and Alton, E.W.F.W. (1998). Gene Therapy for cystic fibrosis. *Biologist* 45, 37-40.
- Strange, K. (1998). Molecular identity of the outwardly rectifying, swelling-activated anion channel: time to reevaluate pICln. *J.Gen.Physiol.* 111, 617-622.
- Strickland, E., Qu, B.H., Millen, L., and Thomas, P.J. (1997). The molecular chaperone Hsc70 assists the in vitro folding of the N-terminal nucleotide-binding domain of the cystic fibrosis transmembrane conductance regulator. *J.Biol.Chem.* 272, 25421-25424.
- Stroffekova, K., Kupert, E.Y., Malinowska, D.H., and Cuppoletti, J. (1998). Identification of the pH sensor and activation by chemical modification of the ClC-2G Cl- channel. *American Journal of Physiology* 275, C1113-C1123.
- Stutts M.J., Canessa C.M., Olsen J.C., Hamrick M., Cohn J.A., Rossier B.C., and Boucher R.C. (1995). CFTR as a cAMP-Dependent Regulator of Sodium Channels. *Science* 269, 847-850.
- Sugita, M., Yue, Y., and Foskett, J.K. (1998). CFTR Cl- channel and CFTR-associated ATP channel: distinct pores regulated by common gates. *EMBO J.* 17, 898-908.

- Tabcharani, J.A., Lindsell, P., and Hanrahan, J.W. (1997). Halide permeation in wild-type and mutant CFTR chloride channels. *J.Gen.Physiol.* *110*, 341-354.
- Tasch, J.E., Zerhusen, B., Zhao, J., Ma, J., and Davis, P.B. (1999). Functional dissection of the R domain of cystic fibrosis transmembrane conductance regulator. *FEBS Lett.* *445*, 63-68.
- Taylor, C.J., Baxter, P.S., Hardcastle, J., and Hardcastle, P.T. (1988). Failure to induce secretion in jejunal biopsies from children with cystic fibrosis. *Gut* *29*, 957-962.
- Terayama H. (1952). Method of colloid titration (A New Titration between Polymer ions). *Journal of Polymer Science* *8*, 243-253.
- Thiemann, A., Grunder, S., Pusch, M., and Jentsch, T.J. (1992). A chloride channel widely expressed in epithelial and non-epithelial cells. *Nature* *356*, 57-60.
- Thornhill, W.B., Wu, M.B., Jiang, X., Wu, X., Morgan, P.T., and Margiotta, J.F. (1996). Expression of Kv1.1 delayed rectifier potassium channels in Lec mutant Chinese hamster ovary cell lines reveals a role for sialidation in channel function. *J.Biol.Chem.* *271*, 19093-19098.
- Townsend, R.R., Lipniunas, P.H., Tulk, B.M., and Verkman, A.S. (1996). Identification of protein kinase A phosphorylation sites on NBD1 and R domains of CFTR using electrospray mass spectrometry with selective phosphate ion monitoring. *Protein Sci.* *5*, 1865-1873.
- Trapp, S., Tucker, S.J., and Ashcroft, F.M. (1998). Mechanism of ATP-sensitive K channel inhibition by sulfhydryl modification. *J.Gen.Physiol.* *112*, 325-332.
- Trout, L., King, M., Feng, W., Inglis, S.K., and Ballard, S.T. (1998). Inhibition of airway liquid secretion and its effect on the physical properties of airway mucus. *American Journal of Physiology* *274*, L258-L263.
- Tschudi, M.R., Mesaros, S., Luscher, T.F., and Malinski, T. (1996). Direct in situ measurement of nitric oxide in mesenteric resistance arteries. Increased decomposition by superoxide in hypertension. *Hypertension* *27*, 32-35.
- Tsuura, Y., Ishida, H., Hayashi, S., Sakamoto, K., Horie, M., and Seino, Y. (1994). Nitric oxide opens ATP-sensitive K⁺ channels through suppression of phosphofruktokinase activity and inhibits glucose-induced insulin release in pancreatic β cells. *J.Gen.Physiol.* *104*, 1079-1099.
- Tu, Q., Velez, P., Cortes-Gutierrez, M., and Fill, M. (1994). Surface charge potentiates conduction through the cardiac ryanodine receptor channel. *J.Gen.Physiol.* *103*, 853-867.
- Vaandrager, A.B., Tilly, B.C., Smolenski, A., Schneider-Rasp, S., Bot, A.G.M., Edixhoven, M., Scholte, B.J., Jarchau, T., Walter, U., Lohmann, S.M., Poller,

- W.C., and De Jonge, H.R. (1997). cGMP stimulation of cystic fibrosis transmembrane conductance regulator Cl⁻ channels co-expressed with cGMP-dependent protein kinase type II but not type I β . *J.Biol.Chem.* 272, 4195-4200.
- Vajanaphanich, M., Schultz, C., Rudolf, M.T., Wasserman, M., Enyedi, P., Craxton, A., Shears, S.B., Tsien, R.Y., Barrett, K.E., and Traynor-Kaplan, A.E. (1994). Long-term uncoupling of chloride secretion from intracellular calcium levels by Ins(3,4,5,6)P₄. *Nature* 371, 711-714.
- Van Damme M-P.I., Blackwell S.T., Murphy W.H., and Preston B.N. (1992). The measurement of negative charge content in cartilage using a colloid titration technique. *Anal.Biochem.* 204, 250-257.
- Van Damme M-P.I., Tiglias J., Nemat N., and Preston B.N. (1994). Determination of the Charge Content at the Cell Surface of Cells Using a Colloid Titration Technique. *Anal.Biochem.* 223, 62-70.
- Vaquero, E., Molero, X., Puig-Divi, V., and Malagelda, J.-R. (1998). Contrasting effects of circulating nitric oxide and nitrenergic transmission on exocrine pancreatic secretion in rats. *Gut* 43, 684-691.
- Vargas F.F., Osorio H.M., Basilio C., De Jesus M., and Ryan U.S. (1990). Enzymatic Lysis of Sulfated Glycoaminoglycans Reduces the Electrophoretic Mobility of Vascular Endothelial Cells. *Memb.Biochem.* 9, 83-89.
- Verdon, B., Winpenny, J.P., Whitfield, K.J., Argent, B.E., and Gray, M.A. (1995). Volume-activated chloride currents in pancreatic duct cells. *J.Membr.Biol.* 147, 173-183.
- Voilley, N., Galibert, A., Bassilana, F., Renard, S., Lingueglia, Coscoy, S., Champigny, G., Hofman, P., Lazdunski, M., and Barbry, P. (1997). The amiloride-sensitive Na⁺ channel: from primary structure to function. *Comparative Biochemistry & Physiology, Part A Physiology.* 118, 193-200.
- Wagner, J.A., Cozens, A.L., Schulman, H., Gruenert, D.C., Stryer, L., and Gardner, P. (1991). Activation of chloride channels in normal and cystic fibrosis airway epithelial cells by multifunctional calcium/calmodulin-dependent protein kinase. *Nature* 349, 793-796.
- Ward, C.L., Krouse, M.E., Gruenert, D.C., Kopito, R.R., and Wine, J.J. (1991). Cystic fibrosis gene expression is not correlated with rectifying Cl⁻ channels. *Proc.Natl.Acad.Sci.USA* 88, 5277-5281.
- Warth, R. and Greger, R. (1993). The ion conductances of CFPAC-1 cells. *Cell.Physiol.Biochem.* 3, 2-16.

- Watt, W.C., Lazarowski, E.R., and Boucher, R.C. (1998). Cystic fibrosis transmembrane regulator-independent release of ATP. Its implications for the regulation of P2Y2 receptors in airway epithelia. *J.Biol.Chem.* 273, 14053-14058.
- Welsh, M.J., Li, M., and McCann, J.D. (1989). Activation of normal and cystic fibrosis Cl⁻ channels by voltage, temperature, and trypsin. *J.Clin.Invest.* 84, 2002-2007.
- Welsh, M.J. and Liedtke, C.M. (1986). Chloride and potassium channels in cystic fibrosis airway epithelia. *Nature* 322, 467-470.
- Wen, Z.Y., Song, L.C., Yan, Z.Y., Lu, Z.G., Sun, D., and Chien, S. (1998). An animal model to study erythrocyte senescence with a narrow time window of erythrocyte production. *Clinical Hemorheology & Microcirculation* 18, 75-84.
- Wesley, A., Forstner, J., Qureshi, R., Mantle, M., and Forstner, G. (1983). Human intestinal mucin in cystic fibrosis. *Pediatric Research* 17, 65-69.
- Weymer, A., Huott, P., Liu, W., McRoberts, J.A., and Dharmasathaphorn, K. (1985). Chloride secretory mechanism induced by prostaglandin E₁ in a colonic epithelial cell line. *J.Clin.Invest.* 76, 1828-1836.
- White, R.E., Lee, A.B., Shcherbatko, A.D., Lincoln, T.M., Schonbrunn, A., and Armstrong, D.L. (1993). Potassium channel stimulation by naturetic peptides through cGMP-dependent dephosphorylation. *Nature* 361, 263-266.
- Whittle, B.J.R. (1995). Nitric oxide in physiology and pathology. *Histochemical Journal* 27, 727-737.
- Widdicombe, J.H. (1997). Ion Transport by airway epithelia. In *The Lung: Scientific Foundations*. R.G. Crystal and J.B. West, eds. (Philadelphia: Lippencott-Raven), pp. 305-318.
- Widdicombe, J.H. and Widdicombe, J.G. (1995). Regulation of human airway surface liquid. *Respiration Physiology* 99, 3-12.
- Wilson, K.T., Xia, Y., and Musch, M.W. (1994). Sodium nitroprusside stimulates anion secretion and inhibits sodium chloride absorption in rat colon. *J.Pharmacol.Exp.Therap.* 266, 224-230.
- Winpenny, J.P., Harris, A., Hollingsworth, M.A., Argent, B.E., and Gray, M.A. (1998). Calcium-activated chloride conductance in a pancreatic adenocarcinoma cell line of ductal origin (HPAF) and in freshly isolated human pancreatic duct cells. *Pflugers Arch.* 435, 796-803.
- Wright, L.C., Seybold, J., Robichaud, A., Adcock, I.M., and Barnes, P.J. (1998). Phosphodiesterase expression in human epithelial cells. *American Journal of Physiology* 275, L694-L700.

- Wu, D.X., Lee, C.Y., Uyekubo, S.N., Choi, H.K., Bastacky, S.J., and Widdicombe, J.H. (1998). Regulation of the depth of surface liquid in bovine trachea. *American Journal of Physiology* 274, L388-L395.
- Xie, W., Solomons, K.R.H., Freeman, S., Kaetzel, M.A., Bruzik, K.S., Nelson, D.J., and Shears, S.B. (1998). Regulation of Ca²⁺-dependent Cl⁻ conductance in a human colonic epithelial cell line (T84): cross-talk between Ins(3,4,5,6)P₄ and protein phosphatases. *J.Physiol.(Lond.)* 510, 661-673.
- Xiong, H., Li, C., Garami, E., Wang, Y., Ramjeesingh, M., Galley, K., and Bear, C.E. (1999). ClC-2 activation modulates regulatory volume decrease. *J.Membr.Biol.* 167, 215-221.
- Xu, L., Eu, J.P., Meissner, G., and Stamler, J.S. (1998). Activation of the cardiac calcium release channel (ryanodine receptor) by poly-S-nitrosylation. *Science* 279, 234-237.
- Xu, X., Star, R.A., Tortorici, G., and Muallem, S. (1994). Depletion of intracellular Ca²⁺ stores activates nitric oxide synthase to generate cGMP and regulate Ca²⁺ influx. *J.Biol.Chem.* 269, 12645-12653.
- Yamamoto, K. and Yamamoto, M. (1991). Changes in the cell surface of human diploid fibroblasts during cellular aging. *Mutation Research* 256, 169-175.
- Zeitlin, P.L. (1999). Novel pharmacological therapies for cystic fibrosis. *J.Clin.Invest.* 103, 447-452.
- Zhang, Y. and Engelhardt, J.F. (1999). Airway surface fluid volume and Cl content in cystic fibrosis and normal bronchial xenografts. *Am.J.Physiol.Cell Physiol.* 276, C469-C476.
- Zhang, Y.L., Doranz, B., Yankaskas, J.R., and Engelhardt, J.F. (1995). Genotypic analysis of respiratory mucous sulfation defects in cystic fibrosis. *J.Clin.Invest.* 96, 2997-3004.
- Zufall, F. and Leinders-Zufall, T. (1997). Identification of a long-lasting form of odor adaptation that depends on the carbon monoxide cGMP second-messenger system. *J.Neurosci.* 17, 2703-2712.