

Reliability of a North American Freight Railcar Air Brake Inspection Method Using Wheel  
Temperature Detectors

by

Dominika JUHASZOVA

A thesis submitted in partial fulfillment of the requirements for the degree of

Master of Science  
in  
Engineering Management

Department of Mechanical Engineering  
University of Alberta

© Dominika JUHASZOVA, 2018

## **Abstract**

This research evaluates the current legally mandated train air brake test within Canada and provides further comparison with a technology driven approach used by Canadian Pacific known as Automated Train Brake Effectiveness (ATBE). The current No. 1 Air Brake Test mandated by Transport Canada is performed on static trains as opposed to the technology-driven approach applied to moving (dynamic) trains using wayside detectors, namely wheel temperature detectors (WTD) and automated equipment identification (AEI).P

ATBE triggers both Hot and Cold Wheel alarms based on designed detection site locations. Flat locations aim to verify that no excessive wheel temperatures (hot wheels) are present within passing trains. These sites are located where no brake application is needed and serve to identify complete train air brake release. Hot wheels can be indicative of hand brakes left on, sticking brakes, or other braking system defects. Contrarily, hills/grades where train air brakes are intentionally applied while descending to control speed are used to evaluate ineffective brakes. Wheel temperatures measured below threshold or “cold” in comparison to the train average temperature suggest ineffective braking on the corresponding railcar as identified by AEI. Railcars with cold wheels or hot wheels not caused by hand brakes are Single Car Air Brake Tested and repaired prior to return to service.

In this work, detection rates of both inspection methods together with the reliability of these methods to identify air brake failures are assessed. Maintenance records of railcars which failed air brake inspections are checked for the repairs associated with the brake defects which would cause cold or hot wheels. Additionally, methods to assess the impact of dynamic braking on the ATBE process are discussed.

Research has shown that ATBE has considerably higher alarm rates than the manual air brake test. As both inspection methods are able to identify not only air brake failures, but also defects not related to air brake systems, an inspection which results in increased railcar repairs suggests improved fleet health.

*Keywords:* railcar, air brakes, defect, inspection, condition monitoring, wheel temperature detectors.

This page intentionally left blank

## **Acknowledgements**

First and foremost, I would like to thank my master thesis supervisor, Dr. Michael G Lipsett, for his support, guidance, and the insightful conversations he has provided during my time at the University of Alberta, whilst allowing me to work in my own way and to grow as an engineer and a person.

I would like to thank Canadian Pacific Rail and its employees for the hard work and innovations in the rail industry, and for the chance to work at CP's headquarters and learn from the subject matter experts. Especially, thank you, Kyle Mulligan, for taking an active role in my graduate research project. Thank you, for finding time in your busy schedule for my research presentations rehearsals and to advise, review, and comment on my thesis with a high level of detail and precision. I express my gratitude to Abe Aronian for teaching me how to analyze locomotive downloads and sharing his expertise on air brake system inspection processes. Thank you, Frank Bafaro, for your patience in answering my many questions regarding the air brake tests, maintenance records, and overall operations in Golden yard.

I would also like to thank Yan Liu and Luke Steiginga with the National Research Council of Canada and Sharon Philpott and Nicholas Hoffmann with Transport Canada for their useful comments on how to improve the scope of the project. Moreover, I would like to acknowledge NRC and TC for partially funding this project.

Thank you, Bill Gallagher with New York Air Brake, for sharing your knowledge on train brake systems and Single Car Air Brake Test.

I would also like to thank Dr. Derek Martin and Dr. Michael Hendry with the Canadian Rail Research Laboratory for the opportunity to work on this project, and for funding.

Thanks to the American Railway Engineering and Maintenance-of-Way Association educational foundation for the Communications & Signals Functional Group scholarship.

My friends Michaela Fedorova, Lindsey Lam, Alejandro Eufrazio Aguilera, and my husband Milan Dubinsky are the people whose support and love gave me strength to complete a successful Master's Thesis. Thank you!

## Table of Contents

Abstract .....	ii
Acknowledgements .....	v
Table of Contents .....	vii
List of Tables .....	ix
List of Figures and Illustrations .....	x
List of Symbols, Abbreviations and Nomenclature .....	xii
Units Conversion Table .....	xiv
<b>1 Introduction .....</b>	<b>1</b>
<b>1.2 Problem Statement .....</b>	<b>2</b>
<b>1.3 Thesis Objectives .....</b>	<b>3</b>
<b>1.4 Methodology .....</b>	<b>4</b>
<b>1.4.1 Data Collection.....</b>	<b>5</b>
<i>Event Recorder .....</i>	<i>6</i>
<b>1.5 Thesis Organization.....</b>	<b>7</b>
<b>2 Background .....</b>	<b>8</b>
<b>2.1 Railcar Brake Systems .....</b>	<b>8</b>
<b>2.1.1 Air Brake Systems.....</b>	<b>8</b>
<b>2.1.2 Dynamic Braking .....</b>	<b>10</b>
<b>2.2 Air Brake Inspection Methods .....</b>	<b>12</b>
<b>2.2.1 Manual Inspection.....</b>	<b>12</b>
<i>No. 1 Brake Test .....</i>	<i>12</i>
<i>Soap-and-bubble Testing .....</i>	<i>14</i>
<b>2.2.2 Semi-Automated .....</b>	<b>15</b>
<i>Ultrasonic leakage detection of air leaks on air brakes.....</i>	<i>16</i>
<i>Automated Single Car Air Brake Test.....</i>	<i>16</i>
<b>2.2.3 Automated Inspection.....</b>	<b>18</b>
<i>Wayside Detection Systems .....</i>	<i>20</i>
<i>Air Brake Effectiveness Evaluation Using WTDs.....</i>	<i>21</i>
<b>3 Current Processes Used at Canadian Pacific .....</b>	<b>27</b>
<b>3.1 No. 1 Brake Test.....</b>	<b>27</b>
<b>3.2 Automated Air Brake Effectiveness (ATBE) .....</b>	<b>31</b>
<b>3.2.1 Hot and Cold Wheel .....</b>	<b>32</b>
<b>3.3 Automated Single Car Air Brake Test .....</b>	<b>38</b>
<b>3.4 Air Brake Inspection and Bad Ordering Process.....</b>	<b>39</b>
<b>4 Comparative Assessment of Manual and Automated Air Brake Inspection .....</b>	<b>41</b>
<b>4.1 Coal Fleet.....</b>	<b>41</b>

4.1.1 ATBE Validity.....	42
4.1.2 ATBE Reliability .....	44
<i>Cut Out Cars</i> .....	49
4.1.3 No Defect Found .....	51
4.1.4 No. 1 Brake Test .....	54
<i>Limitation of data</i> .....	54
4.3 Grain Fleet .....	55
4.3.1 Detection Rate .....	56
<i>Results</i> .....	57
4.3.1 Field Testing: Comparison of ATBE vs. No.1 Brake Test vs. Single Car Air Brake Test .....	58
<i>Findings</i> .....	60
4.4 Comparative Assessment .....	66
4.5 Enhanced ATBE Reliability – Multiple Cold Wheels & Multiple Detectors Hit Rules .....	68
<b>5 Impact of Dynamic Braking on the Automated Train Brake Effectiveness Process</b>	<b>70</b>
5.1 Dynamic Braking Impact Calculation Process .....	70
<i>Assumptions for calculations</i> .....	78
<i>Dynamic braking calculation formulas</i> .....	79
5.2 Dynamic Braking Calculation Results .....	81
<b>6 Conclusion and Future work</b> .....	<b>85</b>
6.1 Conclusion .....	85
6.1.1 Limitations .....	86
6.2 Recommendations to Industry .....	87
6.3 Future Work.....	87
References .....	89



## List of Tables

Table 1. Sources and limitations of collected data .....	6
Table 2. Factors impacting the quality of manual inspection.....	15
Table 3. Single Car Air Brake Test failure modes .....	18
Table 4. Confusion matrix .....	25
Table 5. Conditions verified during a visual inspection .....	31
Table 6. ABTE criteria for the coal gondola railcars running on the Coal loop in British Columbia .....	32
Table 7. List of valid repairs based on Car Components, Why Made and Job Codes.....	46
Table 8. ATBE alarms per 101 coal trains.....	48
Table 9. Cut out car temperatures.....	50
Table 10. Cold wheel criteria for grain hopper railcars .....	55
Table 11. Comparison between the No.1 Brake Test and ATBE.....	58
Table 12. Small-scale testing results.....	61
Table 13. Repairs and cold wheels.....	65
Table 14. Comparative Assessment.....	67
Table 15. Results of enhanced ATBE on coal fleet data .....	69
Table 16. Coal trains locomotive downloads.....	71
Table 17. Wayside temperature detectors data.....	76
Table 18. Detection sites specifications.....	78
Table 19. Dynamic braking results.....	82

## List of Figures and Illustrations

Figure 1. Railcar Air Brake System .....	9
Figure 2. Dynamic Brake .....	11
Figure 3. Detector scan profile .....	19
Figure 4. Configuration of detector-based inspection system .....	19
Figure 5. a) Railcar mechanic drives alongside the train and visually inspects conditions depicted on the b) during the No. 1 Brake Test in the Alyth yard, Calgary, Alberta, Canada.....	28
Figure 6. Wheel Temperature Distribution.....	33
Figure 7. Canadian Pacific network in Western Canada.....	36
Figure 8. Inspection and Maintenance Process following ATBE in BC Coal Loop.....	39
Figure 9. Golden Yard Map .....	40
Figure 10. Alarmed railcars per train .....	42
Figure 11. ATBE validity rate .....	43
Figure 12. ATBE accuracy and total repair rate .....	45
Figure 13. Valid Repairs .....	47
Figure 14. Wheel Temperature Trending .....	48
Figure 15. Cut out brakes railcar temperature .....	51
Figure 16. No Defect Found by number of cold wheels .....	52
Figure 17. Temperature trending of NDF cars.....	52
Figure 18. Other Brake System Repairs .....	53
Figure 19. Mechanical Repairs.....	54
Figure 20. Wheel temperature distribution of coal and gran trains .....	56

Figure 21. SCABT test set up .....	60
Figure 22. Wheel temperature distribution before the repair .....	62
Figure 23. Wheel temperature distribution after repair .....	62
Figure 24. Leakage detected during the SCABT test.....	63
Figure 25. Worn out brake shoes.....	64
Figure 26. Grain Hopper Railcar Defects (multiple railcars) .....	64
Figure 27. Train handling data .....	73
Figure 28. Track profile of the grade in Mountain subdivision .....	77
Figure 29. Brake Horse Power required to control train speed .....	83

## List of Symbols, Abbreviations and Nomenclature

°C	Degrees Celsius
°F	Degrees Fahrenheit
AAR	Association of American Railroads
ASCTD	Automatic Single Car Test Device
ATBE	Automated Train Brake Effectiveness
ATV	All-Terrain Vehicle
B/O	Bad Order
BOE	Bad Order when Empty
BC	British Columbia
BHP	Brake Horse Power
BMB	Body Mounted Brakes
BSF	Brake Shoe Force
cfm	Cubic Feet per Minute
CMS	Condition Monitoring System
CP	Canadian Pacific
CRB	Car Repair Billing
CW	Cold Wheel Alarm
EHMS	Equipment Health Monitoring System
FAST	Facility for Accelerated Service Testing
HW	Hot Wheel Alarm
lbs	pound
MP	Mile Post
mph	Miles per Hour
NDF	No Defect Found
NRC	National Research Council of Canada
S&M	Safety and Maintenance Inspection
SCABT	Single Car Air Brake Test
SIL	Safety Inspection Location
psi	Pounds per Square Inch
R BOE	Repetitive Bad Order when Empty
TC	Transport Canada
TDTI	Technology Driven Train Inspection
TMB	Truck Mounted Brakes
TMS	Thermal Mechanical Shelling
TP	True Positive
TRR	Total Repair Rate
TTCI	Transportation Technology Center Inc.
ULD	Ultrasonic Leakage Detection
USA	United States of America

WTD

Wheel Temperature Detectors

## Units Conversion Table

### Imperial System

1 inch (in)  
1 foot (ft)  
1 mile (mi)  
1 square inch (sq in)  
1 pound (lbs)  
1 short ton (t)  
1 cubic foot (cu ft)  
1 miles per hour (mph)  
x Degree Fahrenheit (°F)

### International System of Units<sup>1</sup>

0.0254 meters (m)  
0.3048 meters (m)  
1 609.344 meters (m)  
0.00064516 square meters (m<sup>2</sup>)  
0.45359237 kilograms (kg)  
907.18474 kilograms (kg)  
0.0283168466 cubic meter (m<sup>3</sup>)  
0.45 meters per second (m/s)  
 $((x-32)*(5/9))=y$  Degree Celsius (°C)

---

<sup>1</sup> (International Society of Automation, 2017)

## 1 Introduction

The railway industry worldwide is moving toward predictive and proactive rolling stock maintenance built on detector-based inspection systems (Hodge, O'Keefe, Weeks, & Moulds, 2015). To reduce the costs of inspection and maintenance, detectors are used because they improve the efficiency of inspection and increase the reliability of rolling stock (Jamieson & Aronian, 2014). Consolidation of detectors and data into networks in addition to increased computing power enables the development of advanced Equipment Health Monitoring Systems (EHMS) with the option of automated inspection processes. Such automated inspection processes pertain to air brake systems and provide near real-time information about the state of the braking systems. This allows for equipment health monitoring to evaluate trains under movement or dynamic conditions which move beyond current government-regulated inspection requirements.

Since 2011, a waiver has been granted to Canadian Pacific (CP) from Transport Canada (TC) to replace the currently regulated manual No. 1 Brake Test with an automated air brake inspection process known as Automated Train Brake Effectiveness (ATBE). This process is used on coal fleets travelling in a closed loop within British Columbia, Canada, under specified control criteria. ATBE employs wayside wheel temperature detectors (WTD) to measure wheel temperatures relative to train average temperatures and informs about the state of the air brake system such that problems including, but not limited to brakes, stuck brakes, or applied hand brakes are identified (Aronian, Jamieson, & Wachs, 2012). The identified railcar assets are subsequently removed from service and repaired.

Additionally, wayside detectors have shown evidence to exceed the No. 1 Air Brake Test with the ability to assess effectiveness of the braking system (Aronian, Jamieson, & Wachs, 2012)

under dynamic conditions (Robeda, Sammon, & Madrill, 2013). Each unplanned train stop costs \$4000-\$5000 (Shadkar A. M., 2016), therefore, it is expected that employment of the wayside detectors will improve inspection quality, decrease yard dwell of the trains and train delays.

CP has expressed interest in expanding ATBE beyond the coal loop in BC. As a result, a better understanding of the following is necessary:

- full train braking power,
- dynamic braking, and
- the relationship between air brake systems and wheel temperature variability.

## 1.2 Problem Statement

The manual air brake test currently used by Canadian rail companies requires up to 90 minutes in cold conditions to perform. This test is mandated by governing regulatory bodies and has been in existence since prior to the introduction of wheel temperature detector technologies. The adoption of WTDs by many North American Class I railways has provided additional tools to inspectors to improve quality and identification of unseen repairs (Aronian, Mulligan, & De Blois, 2016).

The ATBE process provides a condition based approach to maintenance rather than a reactive approach. This saves time and money through increased efficiency of the operation and improved railcar health (Aronian, Jamieson, & Wachs, 2012), increases the number of brake related repairs, and reduces the need for manual inspection due to a perceived increase in the standard of safety.



The purpose of this research is to further study and analyze the manual and automated air brake inspection methods, and assess the reliability of the ATBE process. Furthermore, this new technology-driven train inspection method is evaluated to determine if it is more reliable than the manual inspection. More precise air brake inspection methods and fault detection will enhance railroad safety and will save money for unplanned service interruptions. More effective operations can be achieved through the enhanced reliability of inspection methods as they can also decrease train delays, increase yard throughput, and eliminate unnecessary repairs.

### 1.3 Thesis Objectives

The main purpose of this research is to evaluate the current air brake inspection process used by Canadian rail companies and to assess the reliability of the automated inspection method using wayside temperature detectors. Additionally, a better understanding of how the ATBE process is impacted by train handling is provided.

The thesis objectives are as follows:

- Compare the manual and automated air brake fault detection processes,
- Assess fault detection and misclassification rates of studied inspection methods, and
- Assess dynamic braking impacts on the ATBE process.

These objectives will be met by the analysis of inspection and maintenance data collected from CP's databases.

## 1.4 Methodology

The analysis methods in this work leverage a combination of qualitative and quantitative methods. This means that data are not only collected from CP's databases, but also from a range of employees. This range includes managers, engineers, supervisors, and railcar mechanics. Qualitative data are gathered through interviews in order to obtain a better understanding of processes in both the Golden and Port Coquitlam yards. Managers and former employees with expertise in air brake testing, and sales representatives from the Wabtec Corp. (an air brake and rail equipment company) were interviewed in Calgary to collect additional data related to air brake inspection and maintenance. Insights into rail safety regulations and rail technology applications have been provided by the federal regulatory body Transport Canada (TC). Finally, the main research project scope (which is greater than this thesis) has been developed by the National Research Council (NRC), with whom we collaborated during field testing, provided expertise in Jim Shoe Testing (Liu, et al., 2017). Quantitative data gathered from the databases include five major sources (Table 1): alarm history, locomotive downloads, Single Car Air Brake Test results, repair history, and ambient temperature. The data sources are discussed in detail later in the next section.

Using the gathered data sources, the following steps are undertaken to meet the thesis objectives of assessment of air brake fault detection rate and reliability of the air brake inspection methods, and assessment of dynamic braking impacts on the ATBE. Additional secondary objectives include

- Understanding both the manual No. 1 Brake Test and ATBE inspection process,
- Developing work flow maps and information flows to understand the inspection, maintenance and data management processes,

- Understanding key performance indicators such as fault detection rate of both inspection methods, ATBE process validity rate, accuracy of air brake tests, and maintenance quality,
- Collecting inspection and maintenance data from available data sources,
- Identifying impacts of environment, dynamic braking, maintenance quality, and data management on the quality of inspections,
- Evaluating the reliability of air brake inspections methods,
- Performing comparative assessment of both the manual/visual and automated inspection methods, and
- Making recommendations for improvement of air brake inspection processes.

#### 1.4.1 Data Collection

Quantitative data for this study are gathered from the CP's online databases and are summarized in Table 1. The first column of Table 1 describes collected data; second column describes sources of data; third column describes data themselves; and the last two columns summarize limitations of collected data and assumptions about the data. In the first row, wheel temperature measurements are described. These measurements are generated by wayside detectors, and once alarmed railcars from Technology Driven Train Inspection (TDTI) reports are automatically generated, then they are processed by further post-processing in central office systems. WTDs also measure ambient temperature, speed in and out, and axle count. Automated Single Car Test data are semi-automatically generated with the input from railcar mechanics after each step of the air brake test. Contrarily, handwritten maintenance records are subject to maintenance quality and proper data management.

## Event Recorder

For assessing dynamic braking, data are collected from locomotive event recorders. Locomotive downloads provide information on train handling and fuel consumption, such as, but not limited to time, distance, speed, acceleration, throttle position, air brake and dynamic brake applications, emergency brake, tractive effort, and horn. These data can be used for a derailment investigation, preventive maintenance, and simulations of new operating rules.

**Table 1. Sources and limitations of collected data**

Data	Generated by	Description	Limitation	Assumption
Alarm history	Wayside Detector	-Wheel temperature -Time between sites -Average Train Temperature -Outliers	TDTI report stored for 30 days only	Detectors work properly, and data are not corrupted
Locomotive Download	Train sensors	Dynamic braking	Manual download	Data are not corrupted
Single Car Air Brake Test	ASCT device/input from a carman	-Automated Single Car Brake Test results -Extended Air Brake Cylinder Leakage Test results	Subject to the use of a 4-port and a carman information entry	The ASCT devices correctly diagnose system defects and railcar mechanics perform required tasks
Repair history	Handwritten ticket entered to the database	Repairs performed	Manual maintenance and data entry	The maintenance meets quality requirements and the maintenance records are proper and data entry complete
Ambient temperature	Detectors	Ambient temperature	Reliability of detectors	The temperature difference between cold wheel sites is not statistically significant

## 1.5 Thesis Organization

This thesis contains 6 chapters. Chapter 1 is introductory and contains a general introduction, thesis objectives, the methodology, and a description of how the thesis is organized.

Chapter 2 contains a literature review and background information to understand air brake inspection methods used by the Canadian railways. We present the advantages and limitations of manual/visual process, including the No. 1 Brake Test and the Soap-and-bubble test; semi-automated processes, including the Ultrasonic leakage detection and the Automated Single Car Air Brake Test; and automated air brake inspections, including the Wireless sensor networks and the ATBE. Additionally, background information of freight railcar braking systems and brake configurations are provided.

Chapter 3 introduces air brake inspection methods currently used at Canadian Pacific, which are the No. 1 Brake Test, the ATBE process, and the Single Car Air Brake Test. Moreover, this chapter outlines the bad ordering process by which railcars are flagged for maintenance and transferred to shops.

Chapter 4 presents the methodical approach used for this study, presents collected data, the analysis process, and results of a comparative assessment of air brake inspection methods performed on coal and grain fleets.

Chapter 5 presents the processes for data gathering and calculating brake force, and effects of dynamic braking on the ATBE process.

Finally, chapter 6 concludes this research and provides recommendations for future work.

## 2 Background

This chapter provides an overview of freight railcar braking systems including air brakes and dynamic brakes. Additionally, this chapter presents air brake inspection methods currently used by Canadian railways.

### 2.1 Railcar Brake Systems

#### 2.1.1 Air Brake Systems

Kinetic energy of a train is removed through the application of brakes. Air brakes use compressed air as the force to apply brake shoe blocks against the wheel surface to slow or stop a train (Figure 1). The air is compressed by a compressor in the locomotive or locomotives and is transmitted to each railcar of the train through a brake pipe. A change in the level of air pressure in the pipe causes a change in the state of the brake on each railcar (Railway-technical, 2016). Currently, the allowable operating air flow limit is 60 Cubic Feet per Minute (cfm) throughout the train and a brake pipe pressure gradient of 15 pounds per square inch (psi) between head-end and tail-end (Aronian, Wachs, Jamieson, Carriere, & Gaughan, 2012). These limits allow for safe train operation (Harubin, 1980) and operation of the air brake system. Brakes are applied by reducing brake pipe pressure and released once brake pipe pressure is increased by a minimum of 2 psi and sensed by railcar control valves. A brake pipe or trainline maintained between 80 and 90 psi implies all railcars are released (AREMA, 2013).

Friction between the moving wheel and the brake shoe increases wheel temperature by converting kinetic energy of a train into heat (Railway-technical, 2016). Changes in wheel temperatures depend on the duration of the brake application and the brake horse power

(Cummings S. , 2009). By each horsepower, the wheel temperature rises roughly 10°F to 20°F (-12.2 to -6.7°C) (Cummings S. , 2009). Moreover, wheel temperature correlates with Brake Shoe Force (BSF) because the wheel tread is used as a brake drum. If there are different BSFs within a railcar, it can cause damage to the wheels due to elevated wheel temperatures and thermal mechanical shelling (TMS). Wheels are more prone to fatigue damage at elevated temperatures because the material mechanical properties are affected at elevated temperatures and residual stresses are reversed from compressive to tensile type which increases wheel failures. The number of wheels in which temperature reaches levels of TMS can be reduced by a factor of eight with the elimination of wheel temperature differences within a railcar (Cummings S. , 2009).

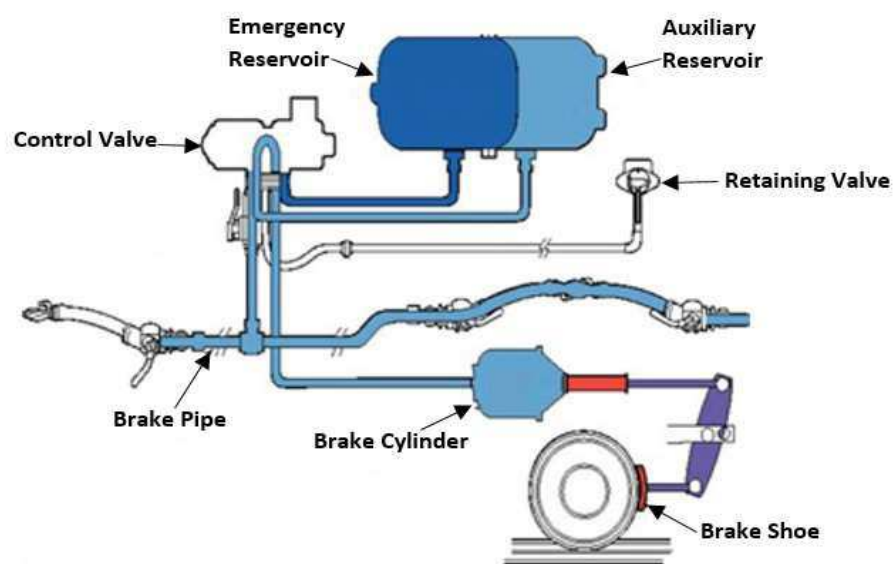

**Figure 1. Railcar Air Brake System**

Modified from (Government of Canada, 2008)

Figure 1 depicts the main components of the railcar air brake system. The auxiliary reservoir is a source of air pressure for service brake applications, and together with an emergency reservoir, is used for a quick air pressure drop during emergency brake applications. Emergency reservoirs

also help with brake pipe pressure recharging. Charging of the reservoirs and air flow to and from of brake cylinder are controlled by a control valve. The control valve is made up of service and emergency portions and a pipe bracket. Air brakes use compressed air in the brake cylinder as the force to apply brake shoe against wheel surface to slow or stop a train. This is achieved through the force of compressed air pressure transferred through a cylinder to the brake rigging and associated brake shoes (Canadian Pacific, 2015). Retainer valves are used on the heavy descending grades to allow air brakes to recharge while they are still applied (Railway-technical, 2016).

There are two main types of brake system configurations used on freight railcars in North America: Body Mounted Brake (BMB) and Truck Mounted Brake (TMB). In the BMB system, the motion of a single brake cylinder is transmitted to each brake shoe on the railcar. This is done through a series of levers and rods connected by pins. The BMB system is divided by the location of the levers and anchoring points. In contrast, the TMB system is more direct-acting and requires fewer components to provide same braking performance as the BMB system (Cummings S. , 2009) (Wabtec Corporation, 2004). Also, the TMB system has one or more brake cylinders in each truck (Cummings S. , 2009).

### 2.1.2 Dynamic Braking

Locomotive traction motors generate power used to move, accelerate and drive train wheelsets (Ahmad, 2013). Electric traction motors also act as generators when they convert mechanical power of moving locomotive into electricity and create a retarding force (Figure 2) (Railway-technical, 2016). This process is called dynamic braking and is used to control speed or stop trains. Depending on train trailing tonnage, the amount of pay load that locomotives are moving,



dynamic brake may be used on heavy descending grades. For larger trailing tonnages, dynamic braking may be supplemented with air brakes.

Figure 2 depicts the use of an electric traction motor as a dynamic brake. Traction motors acting as generators are connected to the resistors through the wire. Resistance slows the generators down and, therefore, cause a train to slow down. Braking effort is controlled through the dynamic brake handle. The excessive electrical current is dissipated through the resistor grids as heat. Resistors grids are cooled using cooling fans to protect them from heat damage (Canadian Pacific, 2015).

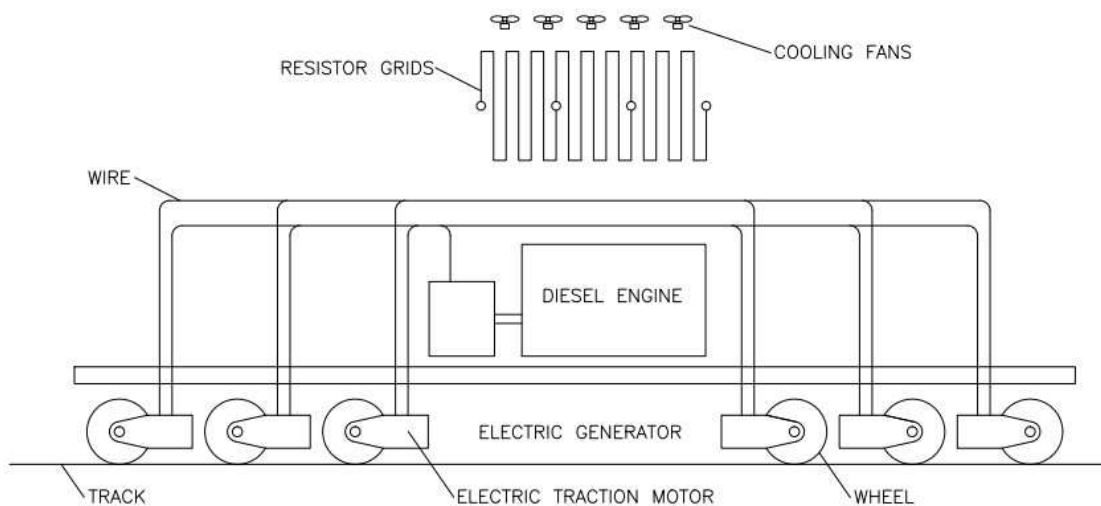

**Figure 2. Dynamic Brake**

Reproduced from (O'Keefe, 2010)

New locomotives, in comparison to older models with DC traction motors have AC traction motors. Locomotives with AC traction motors have a greater retarding force capability at lower speeds. Usually below 25 mph they can generate up to 98 000 lbs (44 452.1 kg) of retarding force (Canadian Pacific, 2015).

## 2.2 Air Brake Inspection Methods

### 2.2.1 Manual Inspection

*Railway Freight and Passenger Train Brake Inspection and Safety Rules* in short, the Train Brake Rules regulated by TC define the minimum requirements for the inspection of air brakes on all passenger and freight trains operating in Canada to ensure safe train operations (Transport Canada, 2014).

#### **No. 1 Brake Test**

The Brake Test Requirements specified in Part II of the Brake Rules require the No. 1 Brake Test to be performed on all made-up trains and railcars added to a train prior to departure from a *safety inspection location (SIL)*. These SIL locations where safety inspections are performed, are determined by the Class I railroads and filled with TC. Trains undergo an inspection at SILs located in the direction of the travel. Blocks of railcars which have not been without air for more than 24 hours, or less than 48 hours with the mechanical department's approval, are excluded from being retested (Transport Canada, 2014).

The No. 1 Brake Test requires an inspection of brake pipe leakage and air flow by a certified car inspector (railcar mechanic). During the No. 1 Brake Test the integrity and continuity of the brake pipe, the condition of the brake rigging on each railcar and the application, and release of the brakes on each railcar are inspected (Transport Canada, 2014). *The No. 1 Brake Test process is further summarized in Chapter 3.*

## **Limitations of the No. 1 Brake Test**

Visual inspection is performed in the yard under static conditions (i.e. the train is not moving). To charge the train air brake system, air is supplied from the yard air plant or from the locomotive. The main technical limitation of this inspection is that during the test the full air brake application, a 26 psi Brake Pipe pressure reduction, is made. This reduction corresponds rarely to actual in-service brake applications. Based on train handling details from locomotive downloads, brake pipe pressure reductions in service are typically between 8 and 15 psi. Another key issue with a visual-based inspection method is that a railcar mechanic visually cannot measure applied brake forces (Robeda, Sammon, & Madrill, 2013). A brake pipe pressure reduction of only 4 to 6 psi is needed to extend the brake cylinder piston, therefore, a brake cylinder may initially extend, giving the perception brakes are applied to full service application, however, over time, if left long enough, leakage may cause the cylinder to retract (Aronian, Mulligan, & De Blois, 2016). This is especially problematic when using in-service (8 to 15 psi) brake applications where it can take up to 50 minutes for a heavy freight train to descend a heavy grade. During the descent, air brakes are applied and released multiple times. The duration of the application in the short intervals is in the range of 3 to 8 minutes and the longer applications are up to 30 minutes. However, during the No. 1 Brake Test performed in a yard, air brakes are applied only as long as it takes the railcar mechanic to drive the length of the train on an ATV (All-Terrain Vehicle), this allows only for momentarily inspection of air brake application. Such short air brake application does not allow for smaller leakages to manifest themselves (Bafaro, 2017) and because larger pressures are used, a longer duration of application would be required to detect an issue. This however is impractical for train operations and yard dwell. The third limitation of the No. 1 Brake Test applies to all manual/visual processes performed by a human railcar mechanic (a certified car inspector) relating to human factors. Daily, railcar mechanics on the rail network perform a high amount of visual inspections where distraction, fatigue, and monotony may impact the quality and efficiency of the inspections (Association of American Railways AAR, TTCI, 2014). Moreover, harsh

winter conditions in Canada, where the temperature during some days drops to -40°F (-40°C) have a negative impact on the quality of the inspections, which can result in incomplete, inconsistent, and less effective inspections (Poddar, 2014). Cold temperature environments also reduce functionality of human bodies and impact concentration (Linne & Juntti, 2011). Furthermore, most of the railway operations in winter are performed during short dark days, in cold, snow, and high humidity, when lower concentration decreases performance and increases the rate of injuries (Linne & Juntti, 2011).

### **Soap-and-bubble Testing**

During a soap-and-bubble test, when brakes are charged with air, brake pipe, control valves, reservoirs, hoses, fittings and gaskets are sprayed with soap which enables a railcar mechanic to see bubbles in the presence of air leakages. However, to see bubbles, railcar mechanics, have to access hard-to-reach areas. Physical detection of air leakage is based on a railcar mechanic's senses to notice noise from a leakage and visually identify the location of the respective leakage. Similar to the No. 1 Brake Test, the ability to perform the soap test in cold weather is affected by difficulties in reaching some areas and decreased capabilities of human senses (Poddar, 2014). Moreover, the soap solution tends to freeze in the low temperatures (Ying, Lipsett, Hendry, & Poddar, 2016).

Additionally, there are technical limitations hindering the soap test (Poddar, 2014):

- Contamination of the test surfaces,
- Temperature of the test specimens,
- Contamination or foaming test liquids,
- Improper viscosity of test liquid,
- Excessive vacuum over the surface of the test liquid, and

- Low surface tension of the test liquid.

Table 2 summarizes factors affecting the quality and efficiency of inspections (Association of American Railways AAR, TCI, 2014), (Butlewski, Jasiulewicz-Kaczmarek, Misztal, & Slawinska, 2015), (EL-Houmayra, 2011):

**Table 2. Factors impacting the quality of manual inspection**

Category	Factor variability
Environment	temperature, time of the day, day light, ergonomic
Human	physiological, psychological
Organizational	training, responsibilities, procedures, postponing decision making and action taking, communication signal, safety
Technical	tools, radio communication
Documentation	records writing and maintenance, access, lessons learned, historical data, real-time data

### 2.2.2 Semi-Automated

Rollingstock air brake systems are inspected both in yards and in shops, where both environments offer different testing conditions and employ different inspection techniques. While the inspection of single railcars in the shop has been performed with the aid of the Single Car Air Brake Test device, yard inspection of a whole consist relies heavily on the human senses. Enhanced air brake leakage inspection methods using Ultrasonic Leakage Detection devices have been tested in recent years in the yard and in the laboratory conditions.

### **Ultrasonic leakage detection of air leaks on air brakes**

Ultrasonic Leakage Detection (ULD) devices have been tested for detecting air leaks and their location. Sounds of these leaks contain ultrasonic frequencies which are beyond human hearing abilities. A portable ULD device with sensors able to measure directional distance, and therefore localize where the sounds originate, can detect such leaks (Ying, Lipsett, Hendry, & Poddar, 2016). ULD devices detect not only leaks found during the manual soap test, but also many additional smaller leaks, which cannot be found by a railcar mechanic, in hard-to-reach locations (Ying, Lipsett, Hendry, & Poddar, 2016).

While this air leakage detection method is more accurate and faster in detecting leaks using a ULD device than a manual inspection using soap, a railcar mechanic is still needed to perform this test. Noises in the yard from normal operation and brake tests performed on other trains may sound like the leaks and confuse even experienced railcar mechanics and lead to false negative results (Ying, Lipsett, Hendry, & Poddar, 2016). Moreover, this test, similar to the manual test, is under static conditions.

### **Automated Single Car Air Brake Test**

An Automated Single Car Test Device (ASCTD) is used for testing, inspection, and diagnosing railcar air brake system issues. A Single Car Air Brake Test (SCABT) is performed in shops on per-car basis, using ASCTD in combination with soap-and-bubble testing, when the railcar (Carriere & Gaughan, 2015) :

- fails the No.1 Brake Test,
- has cut out brakes due to improper release and the railcar was set off (Hot Wheel Alarm),

- railcar has ineffective air brakes (Cold Wheel Alarm), or
- has an expired air brake test interval (5 years).

This SCABT test is semi-automated because a railcar mechanic is required to enter railcar information into the ASCTD, connect railcar to the ASCTD, perform instructions given by the machine, and based on the results of the test perform the necessary repairs. *The SCABT is summarized in chapter 3.*

The SCABT tests can be either performed by attaching the ASCDT to the end of a railcar air hose glad hand or through a 4-port adapter which enables more air flow (faster charging). During the SCABT, a railcar is charged through the brake pipe. This test is similar to the manual inspection because it checks brake pipe and brake cylinder pressure and it monitors air flow (Carriere & Gaughan, 2015). The 4-port method enhances the end-of-car method by monitoring an additional two pressures from the auxiliary reservoir and the emergency reservoir.

The 4-port method allows one to monitor changes in pressure of the brake pipe, auxiliary reservoir, emergency reservoir, and brake cylinder. Therefore, more information is provided to detect direct sources of leakage if there are any (Carriere & Gaughan, 2015). Moreover, this method is able to detect auxiliary reservoir leakage, emergency reservoir leakage, quick service limiting valve defects, and brake pipe/auxiliary release differential. These failure modes are not directly detectable by any other method and they account for up to 20% of failed SCABT (Carriere & Gaughan, 2015).

Carriere and Gaughan from Wabtec Corporation divide types of air brake failures during SCABT test into 3 categories. They are summarized in Table 3. This method is similar to manual inspection methods and is performed under static conditions.

**Table 3. Single Car Air Brake Test failure modes**

Failure Type	Failure Mode
Leakage	Brake Pipe Leakage
	System Leakage
	Brake Cylinder Leakage
Functional	Service Stability
	Minimum Application/Quick Service
	Limiting Valve
	Positive Release
	Empty/Load
	Accelerated Application Valve
	Manual Release Valve
	Emergency Sensitivity / Equalization Pressure
	Measurement
Slack Adjuster Function	

Adapted from (Carriere & Gaughan, 2015)

### 2.2.3 Automated Inspection

#### ***Detectors***

Wheel temperature detectors (WTDs) used at CP are infrared pyrometer-based systems which measure wheel temperatures of passing trains. WTDs measure infrared energy from all passing train wheels. Figure 3 shows the scan profile, of one of many different types and models, of temperature detectors. The WTD measures temperature of all passing wheels and compares the values to a reference level. All measured values are above ambient temperature.

Hot wheels are typically indicative of stuck brakes or applied hand brakes. Excessive wheel temperatures could cause wheels to become distempered and eventually break, resulting in a train accident (AREMA, 2013). Additionally, the damaged wheel could cause damage to the rail and the roadbed as well.



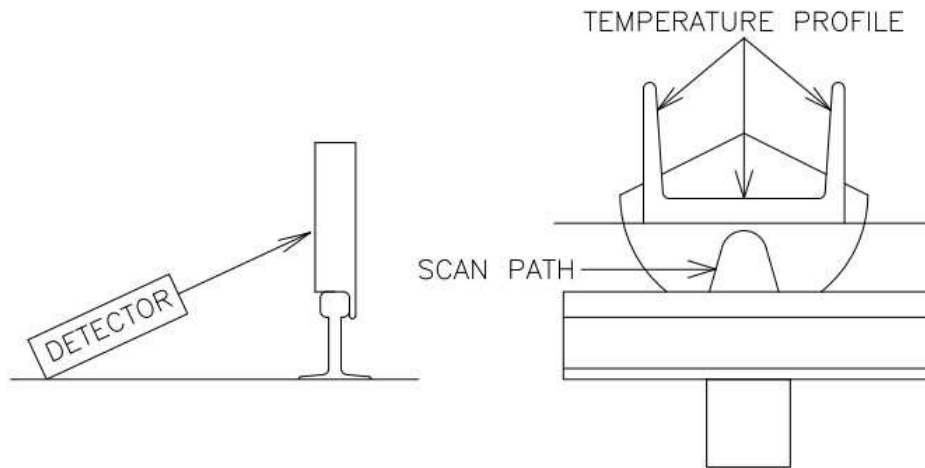

**Figure 3. Detector scan profile**  
 Reproduced from (Zbylut, 2016)

Figure 4 shows the configuration of typical detector-based inspection systems used for condition monitoring. The main components are different detectors types equipped with snow blowers, a communication center, antenna, transducer, transducer cables, and a power supply.

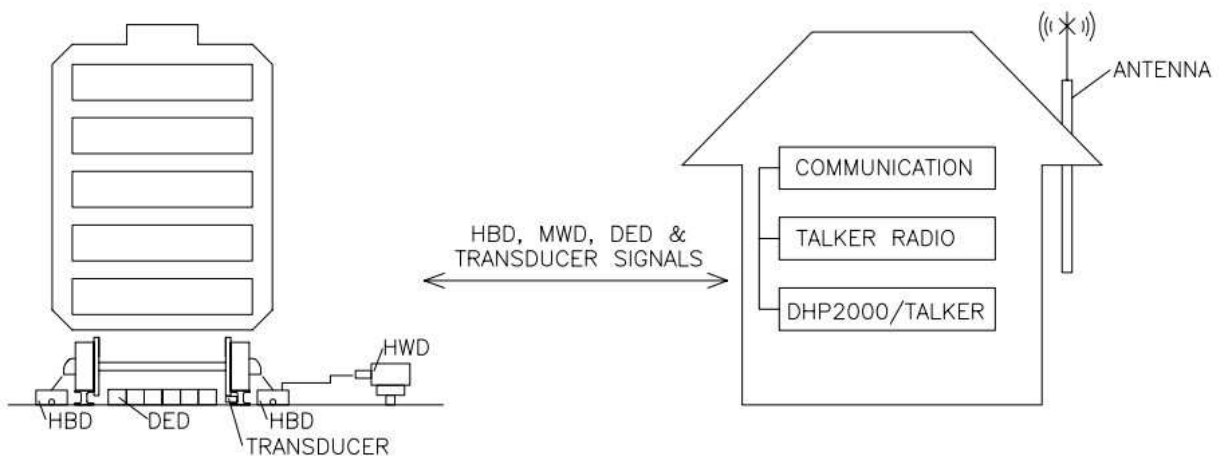

**Figure 4. Configuration of detector-based inspection system**  
 Reproduced from (Shadkar, Lipsett, & Hendry, 2015)

## **Wayside Detection Systems**

Technology Driven Train Inspection (TDTI) is a proposed alternative by the industry to the present method of air brake testing and visual inspection. Wheel detection systems are multifunctional and provide information about axle detection, the number of axles, speed, direction, wheel diameter and wheel center pulse (Frauscher Sensor Technology, 2016), measurement of wheel temperature where brake shoe force is expected can be inferred (Robeda, 2011), and additional measurement of the environment such as humidity and temperature (Frauscher Sensor Technology, 2016).

WTDs have been used since inception by the industry to detect temperature above a pre-set threshold which would be caused by applied handbrakes, defective control valves, or other brake system issues (Robeda, Sammon, & Madrill, 2013) commonly referred to as sticking brakes in the industry. Later, the railroads employed WTDs to detect railcars with considerably lower wheel temperatures than train braking averages. During the known state of braking, this is a sign of brakes not working properly or ineffectively. It has been theorized that the heat generated during the application of the brakes is a measure of retarding force applied on the wheels and is used to evaluate effectiveness of the braking system (Robeda, Sammon, & Madrill, 2013). Therefore, WTDs are usually placed in locations where trains require air brake applications to control speed, such as, when descending a mountain grade, to detect cold wheels. In contrast, high temperature in locations where the brakes are not expected to be applied is thought to be indicative of stuck air brakes or other defects of the braking system. Therefore, hot wheel detection sites are usually located on flat track. This technology goes beyond the ability of a railcar mechanic to visually assess the application and release of the brakes and the length of the piston travel as an indicator of the effectiveness, under static conditions.

## **Air Brake Effectiveness Evaluation Using WTDs**

Since October 2011, CP has been using wheel temperature detectors (WTD) to assess brake effectiveness and to identify effective/inoperative brakes (Aronian, Jamieson, & Wachs, 2012), *further summarized in Chapter 3*. “Effective means a brake that is capable of producing its nominally designed retarding force on the train” (Robeda, Sammon, & Madrill, 2013).

Aronian et al. tested both the No. 1 Brake Test and ATBE at the same time on the same fleet for comparison. The test showed that ATBE had a higher rate of Bad Ordered (B/O) railcars which requires the railcars to travel to the repair shop for a SCABT. Alarmed railcars revealed defects having an impact on braking performance as compared to the defects found by qualified railcar mechanics during the visual No. 1 Brake Test (Aronian, Jamieson, & Wachs, 2012).

Robeda et al. investigated the ability of the detectors to assess the efficiency of brakes on Union Pacific’s coal railcars over a multiple day testing at the Facility for Accelerated Service Testing (FAST) in Pueblo, Colorado, USA. Detectors in service have the rate of flagging ineffective brakes 4 times higher than the rate of the manual inspection. Reasons why railcar mechanics are finding less brake related defects have been reported as a combination of static test conditions, shorter brake applications, the fact that they do not have any means to evaluate effectiveness contrary to verification of application (Robeda, Sammon, & Madrill, 2013), and human factors. *Limitations of the No. 1 Brake Test are discussed further in the section 2.2.1.*

Jamieson & Aronian suggest that the smaller braking force might not only result from the air issue or car/truck-based issues, but can be caused by a mechanical defect such as defective brake beam heads or guides, worn brake shoes or brake levers, or binding brake rigging (Jamieson & Aronian, 2014).

### ***Reliability of Detectors***

Reliability determined by design and construction based on expected operational environment is called inherent reliability. All systems should be created from the material and components eligible for the expected operational conditions, which might be high temperature, humidity, or vibrations. Also, appropriate software must be selected for the operating environment, therefore, the design, evaluation, and selection of the right Condition-Monitoring System (CMS) is critical (Nickerson, Manges, & Munro, 2011).

Detectors should be able to perform reliable measurements about “the presence, speed or direction of an axle under all climatic, technical and operational conditions” (Frauscher Sensor Technology, 2016). Measurement accuracy is subject to external factors such as weather, “longitude, latitude, wind speed and direction” (Elia, Diana, Bocciolone, & Resta, 2006), and “route and travel duration” (Rabatel, Bringay, & Poncelet, 2011). Therefore, detectors must be designed and constructed in a way that will resist harsh weather conditions from -40°F to 160°F (-40°C to 71°C) and provide reliable data, with no “transmission errors, network outages, missing or corrupted data” (Hodge, O'Keefe, Weeks, & Moulds, 2015). For example, data transmission can be affected by the signal strength in tunnels, so, a better understanding of the external factors helps to optimize the placement of sensors in the railway environment. In addition, external factors are needed to be taken into account to avoid false alarms (Hodge, O'Keefe, Weeks, & Moulds, 2015).

Jamieson & Aronian assessed the reliability of detectors and the validity of wheel temperature readings, together with the integrity of data. While WTDs are equipped with snow blowers, harsh winter conditions such as heavy snow can affect validity rates, as well as blowers which are not working properly. ATBE validity rates decrease during cold winter months. They found factors which decrease the validity rate are transducers miscounting axles or trains not meeting the

minimum train average temperature threshold. Therefore, thresholds required re-evaluation as wheel temperature distributions are not perfectly normal, but skewed.

TDTI disadvantages (Jamieson & Aronian, 2014), (Shadkar A. M., 2016):

- false alarms & missed failures,
- detection system technical failures,
- transmission issues & corrupted data,
- scan obstructed by snow or sun.

Sources of detectors and systems failures (Nickerson, Manges, & Munro, 2011):

- the dynamic radio frequency environment,
- changes in the environment,
- other interfering networks,
- algorithms,
- environments (e.g. ambient temperature),
- detector maintenance schedules.

TDTI advantages (Hodge, O'Keefe, Weeks, & Moulds, 2015) (Jamieson & Aronian, 2014):

- higher frequency of monitoring,
- rollingstock monitoring in service under dynamic conditions,
- increases efficiency of the operation by providing immediate results,
- better data accessibility,
- provides predictive and preventive maintenance approach, therefore saving costs,
- objective algorithm acting based on the alarm and validation rules.

### ***Reliability of Fault Detection Methods***

Detector networks measuring the conditions of the rolling stock may use classification to assign patterns to the correct category (Duda & Hart, 2011) and when the sensor detects beyond or below predetermined limits or detects faults, alarms are triggered. Simple algorithms may lead to high amounts of false positives and false negatives, if data are not evaluated within the context, (Hodge, O'Keefe, Weeks, & Moulds, 2015) such as ambient temperature. The ambient temperature affects the temperature of the train and the train mechanics; therefore, it needs to be taken into the account in order to minimalize false alarms (Hodge, O'Keefe, Weeks, & Moulds, 2015), (Poddar, 2014).

Not only do detectors have higher failure rates during the winter (Shadkar, Lipsett, & Hendry, 2015), but also wayside detection systems trigger more alarms, which are considered false upon inspection and maintenance (New York Air Brake, 2017). One of the sources of these false alarms are small leaks in the air brake system. The Association of American Railroads (AAR), allows for leaks smaller or equal to 1 psi during a SCABT. These leaks manifest themselves more during long heavy grade descends and in cold environments. On the other hand, these same leaks pass SCABT testing in the warmer shop (New York Air Brake, 2017).

Table 4 is a confusion matrix which shows the results of predicted condition and actual condition of monitoring system. A *True positive* is when, for example, a railcar has a brake-related defect and a detector triggers an alarm. Contrarily, false positives, also known as Type I errors, occur when a railcar has no defect, but the detector reports a false alarm. A true negative means that the railcar does not receive any alarms because it has no defects. A false negative, known as a Type II error, is when a railcar has a defective brake system, but detectors do not flag the railcar as defective.

**Table 4. Confusion matrix**

	Yes Actual result	No Actual Result
Yes Predicted result	True Positive	False Positive (Type I error)
No Predicted result	False Negative (Type II error)	True Negative

Below are formulas for used to establish reliability of detectors (Fawcett, 2005).

True positive rate or sensitivity (*TPR*)       $TPR = \frac{tp}{tp+fn}$       Equation 2-1

Where:

*tp* – true positive

*fn* – false negative

True negative rate or specificity (*SPC*)       $SPC = \frac{tn}{tn+fp}$       Equation 2-2

Where:

*tn* – true negative

*fp* – false positive

Positive predictive value or precision (*PPV*)       $PPV = \frac{tp}{tp+fp}$       Equation 2-3

Where:

*tp* – true positive

*fp* – false positive

Negative predictive value (*NPV*)       $NPV = \frac{tn}{tn+fn}$       Equation 2-4

Where:

*tn* – true negative

*fn* – false negative

False positive rate or fall-out (*FPR*)       $FPR = \frac{fp}{fp+tn} = 1 - SPC$       Equation 2-5

Where:

*tn* – true negative

$fp$  – false positive

False negative rate or miss rate ( $FNR$ )  $FNR = \frac{fn}{fn+tp}$  Equation 2-6

Where:

$tp$  – true positive

$fn$  – false negative

False discovery rate ( $FDR$ )  $FDR = \frac{fp}{fp+tp} = 1 - PPV$  Equation 2-7

Where:

$tp$  – true positive

$fp$  – false positive

Accuracy ( $ACC$ )  $ACC = \frac{tp+tn}{tp+tn+fp+fn}$  Equation 2-8

Where:

$tp$  – true positive

$tn$  – true negative

$fp$  – false positive

$fn$  – false negative

F1 score or the harmonic mean of precision and sensitivity (F1)

$F1 = 2 * \frac{tp}{tp+fp+fn}$  Equation 2-9

Where:

$tp$  – true positive

$fp$  – false positive

$fn$  – false negative



### 3 Current Processes Used at Canadian Pacific

In this chapter, processes currently used to inspect air brake systems are described. First, the manual/visual No. 1 Brake Test, currently regulated by the federal regulatory body Transport Canada; the second, the Automated Train Brake Effectiveness (ATBE), used by CP to assess effectiveness of braking systems of the coal fleet; the third and final, semi-automated Single Car Air Brake Test.

#### 3.1 No. 1 Brake Test

During the No. 1 Brake Test, the integrity and continuity of the brake pipe, the condition of the brake rigging on each railcar, and the application and release of the brakes on each railcar and piston travel length are visually inspected (Transport Canada, 2014). These conditions are summarized in Table 5 and shown in Figure 5.

Preparation for the No. 1 Brake Test begins when a train reaches the SIL. CP has SILs in Montreal, Toronto, Thunder Bay, Winnipeg, Moose Jaw, Edmonton, Calgary, Golden, Port Coquitlam and, Bensenville and St. Paul (USA). Golden is a designated SIL for the coal fleet. Coal trains undergo a Safety and Maintenance inspection (S&M) every second cycle on the Coal loop, during which entire railcars are inspected including brake rigging, and any significant air leaks and cut out air brakes are visually inspected. Moreover, brake shoes near or below the condemnable limit are replaced to ensure there is a sufficient amount of wear material for two cycles. When railcars found defective en route or during the S&M are removed from the train, the train is ready for the No. 1 Brake Test (Aronian, Jamieson, & Wachs, 2012).

The locomotive and/or yard air line supplies the air to the brake pipe running through the entire train which enables the integrity and continuity of the brake pipe to be inspected. Furthermore, application and release of the brake are verified by visually observing the piston travel as depicted in Figure 5. Additionally, the railcar mechanics visually verify whether the piston travel is within limits (Aronian, Jamieson, & Wachs, 2012). The piston travel limit for the Body Mounted brake system is between 6 and 9 inches (Association of American Railroads, 2015). For various Truck Mounted brake systems, the limit ranges between 5 and 7 inches (Canadian Pacific, 2017). Piston travel limits for the specific TMBs are listed in the AAR Field Manual.

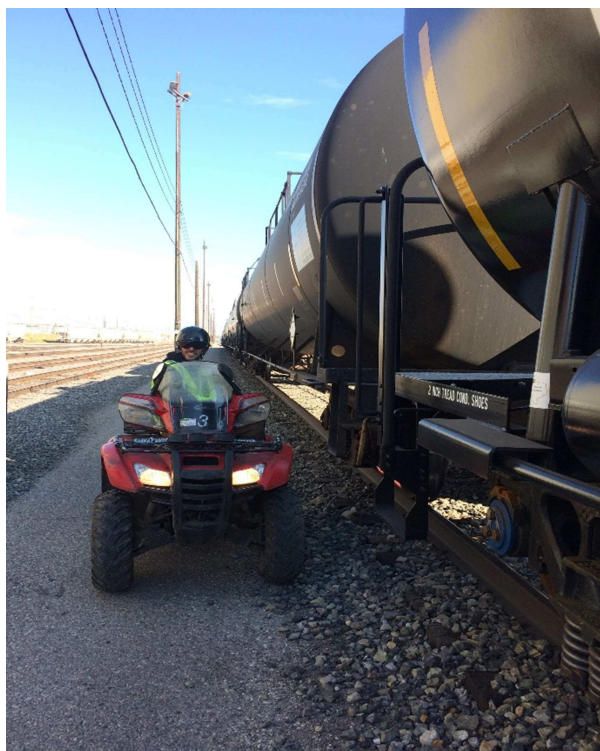

a)

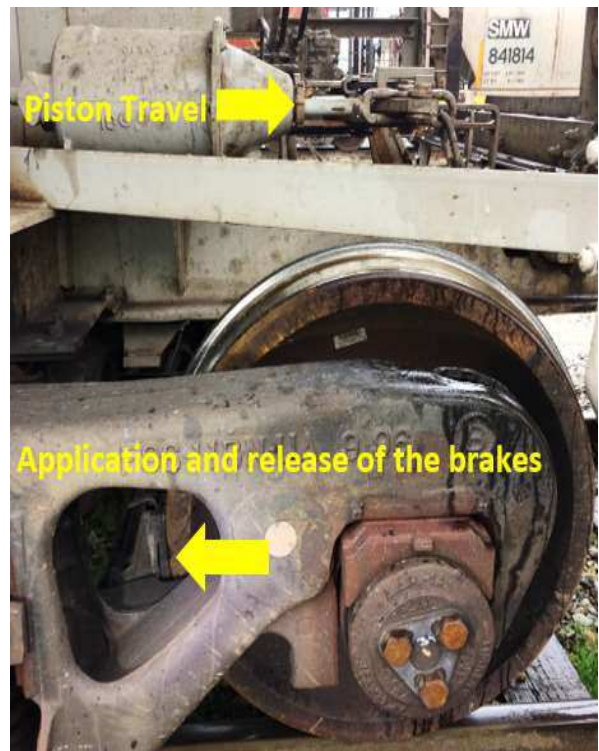

b)

**Figure 5. a) Railcar mechanic drives alongside the train and visually inspects conditions depicted on the b) during the No. 1 Brake Test in the Alyth yard, Calgary, Alberta, Canada**

(Photos by author)

General Operating Instructions – section *Air Brake Tests and Procedures* provides instruction on how to perform the proper No. 1 Brake Test. The following conditions must be met (Canadian Pacific, 2016):

1. Cocks and valves must be in the proper position,
2. Brake pipe air hoses must be coupled,
3. Hand brakes must be released, unless the test is performed on the grade, then hand brakes must remain applied, and
4. The last railcar must have brake pipe pressure not less than 15 psi of the locomotive brake pipe pressure.

A *certified railcar mechanic* may use the Brake Pipe Leakage method or the Air Flow Method to inspect the integrity of the brake pipe prior the No. 1 Brake Test. However, the Air Flow Method is preferred, and the Brake Pipe Leakage Method is used only in cases which do not allow the Air Flow Method to be used (Canadian Pacific, 2016). The Air Flow method can be done using yard air plant or an attached locomotive.

*Freight Car Inspection* book provides instruction for the Air Brake test using yard air plant.

**Air Flow Method procedure using yard air plant** (Canadian Pacific, 2017):

1. Ensure the Air Flow Indicator is operative and calibrated,
2. Air line shall be cleared from foreign particles and condensation prior a yard air plant is connected,
3. Charge train line,
4. Cut off the air supply from the train line,
5. Apply brakes; make 15 psi reduction,
6. Let the train line stabilize, wait 1 minute,
7. Verify that the leakage does not exceed 5 psi per minute,
8. Full service brake application; 25 psi brake reduction,

9. Inspect air brakes. Check air brake application; piston travel; and conditions of brake rigging,
10. Release air bakes, verify brakes release,
11. Apply required number of handbrakes and leave train in emergency,
12. Report the results of the brake test to the crew and update Train Brake Status.

The air flow indicator must not show more than *60 cfm* for the test to be successful.

**Brake Pipe Leakage Method procedure** (Canadian Pacific, 2016):

1. After a signal to apply brakes is given, 15 psi reduction is made,
2. Wait 1 minute after exhaust stops,
3. Cut-out the automatic brakes and wait 1 minute,
4. Monitor brake pipe pressure, record the value, and wait 1 minute,
5. Continue to monitor brake pipe pressure. Brake pipe pressure must not drop more than 5 psi,
6. Equalizing reservoir pressure is reduced by 3 psi below brake pipe pressure,
7. Cut-in the automatic brakes,
8. Reduce brake pipe pressure to a full-service level,
9. After a signal is given, release the automatic brakes,
10. Report the results of the brake test.

Brake pipe leakage must not be more than *5 psi in 1 minute* for the test to be successful.

**No.1 Brake Test** (Canadian Pacific, 2016):

1. After a signal to apply brakes, make full service brake pipe reduction (26 psi),
2. After a signal, release brakes,
3. Update Train Brake Status on Crew-to-Crew form.

**Table 5. Conditions verified during a visual inspection**

Conditions
the integrity and continuity of the brake pipe
the condition of the brake rigging on each railcar
the application and release of the brakes on each railcar
the piston travel on each railcar is within the specified limits

Adapted from (Transport Canada, 2014)

If railcar mechanics discover any brake system defects in the course of the brake testing and the defect is not fixed prior to departure, railcar mechanics must report it, inform the train crew about the results, and then update the Train Brake Status form. According to the TC regulations a train with a No. 1 Brake Test performed may depart with at least 95% of operative brakes from a SIL (Transport Canada, 2014). CP's internal operating rules require trains departing from a SIL to have 100% to provide better customer service and to reduce risk. Additionally, a maximum of two sequential railcars may not have inoperative brakes, and the last three railcars must have operative brakes (Aronian, Jamieson, & Wachs, 2012). Prior to departure, the conductor or locomotive engineer must ensure that the brake test and paperwork have been completed (Transport Canada, 2014).

### 3.2 Automated Air Brake Effectiveness (ATBE)

Since 2011, CP has been using ATBE as an alternative to the visual No. 1 Brake Test on the coal loop in BC under granted exemption (Jamieson & Aronian, 2014). ATBE uses Wayside Detector Technology for the near real-time evaluation of brake *effectiveness* under *dynamic* conditions. Hot Box and Hot Wheel Detectors are located alongside the railways and monitor the wheels of passing trains and evaluate the relative temperature of the wheels within a train (Robeda, Sammon, & Madrill, 2013). After the data are analyzed, the results are sent to the train and the

maintenance crews. Using technology based air brake inspection has enabled CP to move on from a reactive physical inspection to proactive maintenance (Aronian, Jamieson, & Wachs, 2012).

### 3.2.1 Hot and Cold Wheel

The ATBE test uses wayside WTDs to identify hot and cold wheels. According to research conducted by the Transportation Technology Centre, Inc. (TTCI), “a relative indication of wheel temperature is sufficient to identify abnormally Cold Wheel (CW) or Hot Wheels (HW) (and thereby detect and diagnose brake problems) and act accordingly” (Cummings, Tournay, & Gonzales, 2008). CW at the location where a train is descending while applying brakes indicates an ineffective brake. A HW (in comparison to the average of wheel temperatures on a train) indicates a stuck brake, applied hand brakes, or other defects related to the brake system release. Wheel temperature is a subject to conditions such as thickness of the brake shoe, rim thickness, “amount of flange to rail contact”, conditions of truck, rail lubrication, track profile and curvature, and track conditions (Robeda, Sammon, & Madrill, 2013). However, a good statistical model can normalize these variations and identify outliers in the dataset.

**Table 6. ABTE criteria for the coal gondola railcars running on the Coal loop in British Columbia**

Type of Alarm	Criteria
Cold Wheel	Wheel Temperature <70°F (21°C)
	Sigma ≤-3.0
	Train Average Wheel Temperature >180°F <sup>2</sup> (82°C)
Hot Wheel	Wheel Temperature >200°F (93°C)
	Sigma Level ≥3.0

Adapted from (Aronian, Jamieson, & Wachs, 2012)

---

<sup>2</sup> Change of the Train Average Wheel Temperature from 200°F to 180°F (93°C to 82°C) in 2014

The ATBE process criteria for a CW alarm are shown in Table 6. To trigger a CW alarm, a train must reach an average wheel temperature of 180°F (82°C), and an individual wheel must be less than or equal to 70°F (21°C). Additionally, the wheel must be an outlier, denoted by -3 standard deviations from the train average temperature. To flag a wheel with sticking brakes or a hand brake left on, the wheel has to reach a HW temperature threshold of 200°F (93°C) and be an outlier.

Figure 6 shows a wheel temperature distribution of a coal train passing the WTD at Mile Post 111.7 on the CP Mountain subdivision, which is a cold wheel detection site. In the red circle are outliers, wheels with the temperature lower than the CW threshold 70°F (21°C) and are -3 sigmas from the average temperature. Moreover, the train average wheel temperature is 220°F (104°C), therefore, these wheels are reported as CWs.

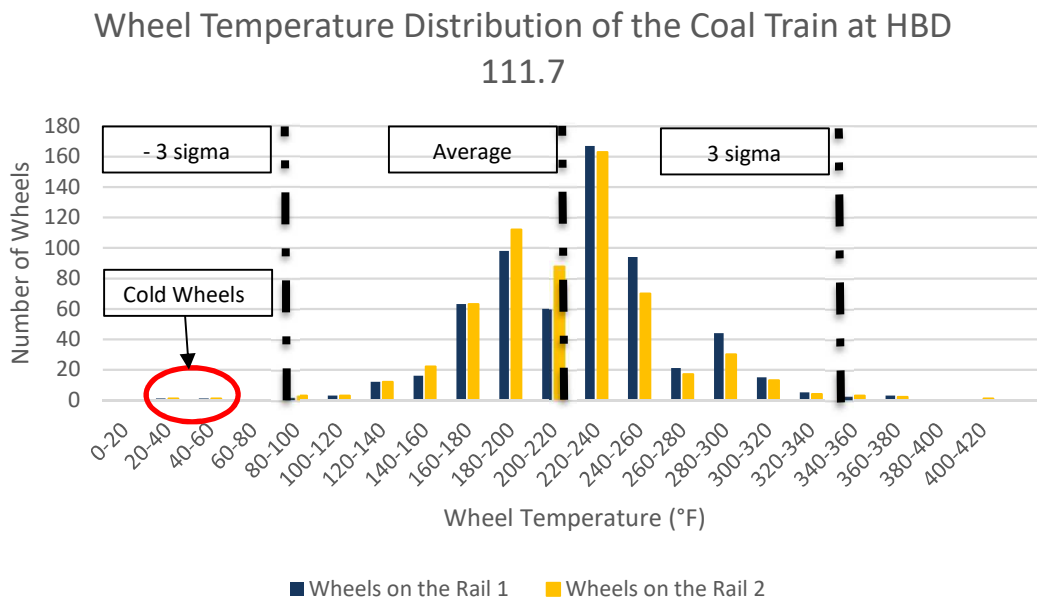

**Figure 6. Wheel Temperature Distribution**

## **BC Coal Loop overview**

The BC Coal Loop trip starts when an empty train departs from the SIL in Golden. Coal trains travel to the coal mines in south-eastern British Columbia. Loaded trains return through Golden, connect to the mainline, and travel to the port on the west coast. There, trains are emptied and when they return to Golden, the trip is completed. Trains then undergo an S&M inspection and all defective railcars are replaced with railcars with a valid SCABT test (known as fill) (Aronian, Jamieson, & Wachs, 2012).

## **ATBE process**

The BC Coal Loop is shown in the Figure 7 and the detailed outline of the process goes as follows (Aronian, Jamieson, & Wachs, 2012).

1. The empty train departs from the safety inspection location in Golden with fully operative brakes.
  
2. The train travels towards the mines and passes the **Hot Wheel Detection Site** on Mile 123.3 in Windermere Subdivision.
  - Results of the inspection are published in the Equipment Health Management System (EHMS) and the crew and mechanical department are notified about the results. Results are stored in the CP's database.
  - If the train receives any HW alarms, the train stops, and the crew inspects the railcars.
  - If the brakes are left on, the crew releases hand brakes. If the problem cannot be solved, the air brakes on the alarmed railcar are cut out. If necessary, railcars are



remarshalled or set off to meet the Train Brake Rules requirements about the quantity and distribution of railcars with air brakes not working.

- The Train Brake Status documentation in crew-to-crew form is updated and the mechanical department is notified about B/O railcars.
3. The loaded train departs from the mines, travels back through Golden and goes to the west coast. It passes the second **Hot Wheel Detection Site** on Mile 54.5 in the CP Mountain Subdivision.
    - If the train receives any hot wheel alarms, the same process follows as in point 2.
  4. The train continues westbound through the **Cold Wheel Detection Sites** on Miles 95.1 and 111.7 in the CP Mountain Subdivision.
    - Results of the inspection are published in the EHMS, and the train crew and mechanical department are notified about the results.
    - If the train receives any CW alarms, railcars are remarshalled or set off, if needed, to meet the Train Brake Rules requirements.
    - Train Brake Status documentation in the crew-to-crew form is updated and the mechanical department is notified about B/O railcars.
  5. The train is unloaded in the port and travels empty back to the SIL in Golden.
    - After passing the detector Mile Post 19.7 in Shuswap, a TDTI report is published.

This process is illustrated in Figure 7.

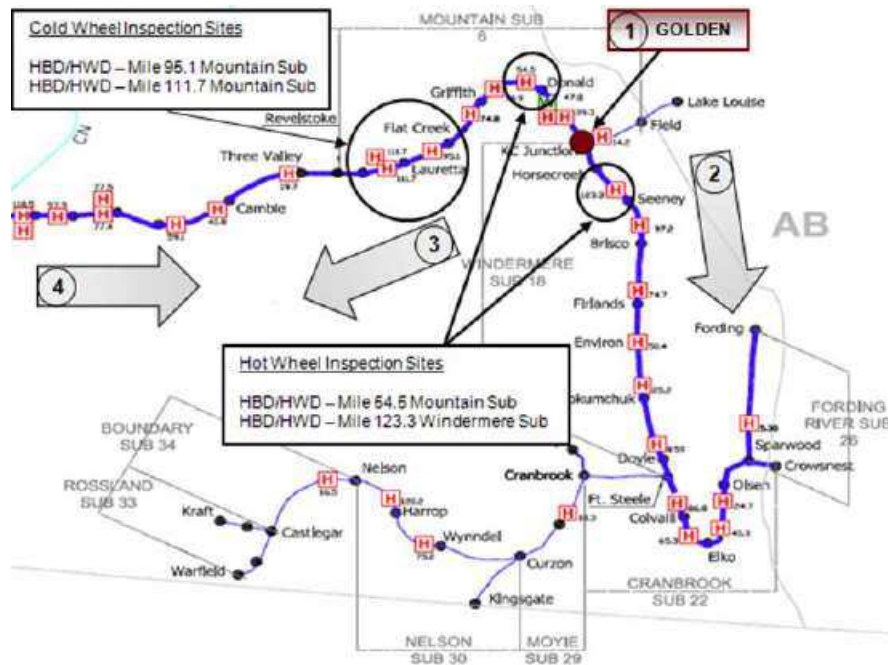

**Figure 7. Canadian Pacific network in Western Canada**

(Aronian, Jamieson, & Wachs, 2012)

TDTI outputs:

**NO EXCEPTION**

On a train with no exceptions to the CW and HW rules, the TDTI report states NO ALARMS. The conductor then reports of any defective equipment recorded on the crew-to-crew form. When needed, the train is filled only with railcars with a valid SCABT. If there is no change to the consist, the train undergoes a S&M every second cycle (Canadian Pacific, 2011).

## **INVALID TEST**

The ATBE process is invalid when a train average wheel temperature does not reach 180°F (82°C) on at least one cold wheel site or does not have a valid report from a hot wheel detection site. ATBE can also fail if a report does not generate due to system errors. In all cases where no report is received, the safest course of action is to perform the manual No. 1 Brake Test. The TDTI reports COULD NOT VERIFY, PLEASE PERFORM NO. 1 BRAKE TEST. The No. 1 Brake Test is performed on the entire train, and railcars which fail are sent to a shop for a SCABT, Extended Cylinder Leakage test, and repair (Canadian Pacific, 2011).

## **ALARM EXCEPTION**

If the train receives HW alarm, then the train is stopped at a siding and inspected. HW railcars, on which the crew found the alarm was triggered because a hand brake has not been released, have the hand brake released by the crew and the event is reported on the crew-to-crew form. Railcars with HW that have no visible issue and no hand brake applied, have their brakes cut out and continue their cycle. Similarly, railcars with a CW continue until the end of the cycle (Canadian Pacific, 2011). A CW railcar may be remarshalled or set out if the train is not compliant with TC regulations: two sequential railcars with inoperative air brakes and/or the last 3 railcars on train must have operative brakes. The train crew must ensure compliance. The TDTI report states COLD and/or HOT WHEEL ALARM, and lists railcar ID and wheels with the ineffective brakes for mechanical handling.

When an empty train arrives to the yard, the shop planner verifies any additional railcars that have been found to be defective and enters the alarmed railcars into the maintenance system Car Repair Billing (CRB). B/O railcars are removed from the train and transferred to the shop for inspection and maintenance (Canadian Pacific, 2011).

### 3.3 Automated Single Car Air Brake Test

Railcars which fail either of the air brake inspections, the No. 1 Brake Test or ATBE, must pass a SCABT as per TC waiver, prior to re-entering service (Liu, et al., 2017). Flagged railcars are set off and assigned to a railcar mechanic, who will look up the specific location of alarmed wheels in CRB to narrow down the area of potential defects (Jamieson & Aronian, 2014). The railcar mechanic visually inspects this location for any obvious defects, such as worn-out brake shoes, missing pins, levers, rigging binds or fouts, bent brake beams, and hand brakes. *Slack adjusters are shortened, if needed, before the SCABT.* The railcar mechanic also verifies if hoses are in-date, and if not, then the railcar mechanic replaces them (Canadian Pacific, 2011). A railcar is also inspected for all other mechanical defects prior to being released from the shop.

At the beginning of a SCABT, a correct setting of the Empty/Load device is verified, and the air brakes are fully charged. CP uses the Wabtec ASCTD for the SCABT, which can be done through the end of car or via the 4-port connector. Data analysis has shown that 93% of CW railcars during the winter months in 2016 have been tested through end of car.

ASCTD tests for the following: brake pipe leakage, system leakage, retainer leakage, service stability, emergency vent, brake cylinder, reservoirs, emergency accelerated release, minimum application, applied leakage test, service release test, and empty/load test [Wabtec report]. After the test is completed, the ASCTD issues a detailed report with the measured values and test results (whether the railcar failed, the railcar passed, or the railcar mechanic aborted the test). If the railcar fails, then the test report states the error. In 2016, 53% of the tested railcars failed SCABT. After repair, all railcars passed the test.

The SCABT is followed by an Extended Brake Cylinder Leakage test. Before an empty train departs from the yard in Golden with 100% operative brakes, a Pre-trip Locomotive Air Brake Test is

required to restart the air brake system and avoid HW alarms by ensuring proper air brake release. When a test is performed, the resulting information are logged in an Event Recorder device onboard the locomotive.

### 3.4 Air Brake Inspection and Bad Ordering Process

The air brake inspection process follows the diagram shown in Figure 8 and the map in Figure 9. Upon arrival of the train at the Golden yard, EHMS and CRB stores the results of the ATBE process. Trains which did not received a valid ATBE test or did not have a TDTI report published must undergo the No. 1 Brake Test (Figure 8).

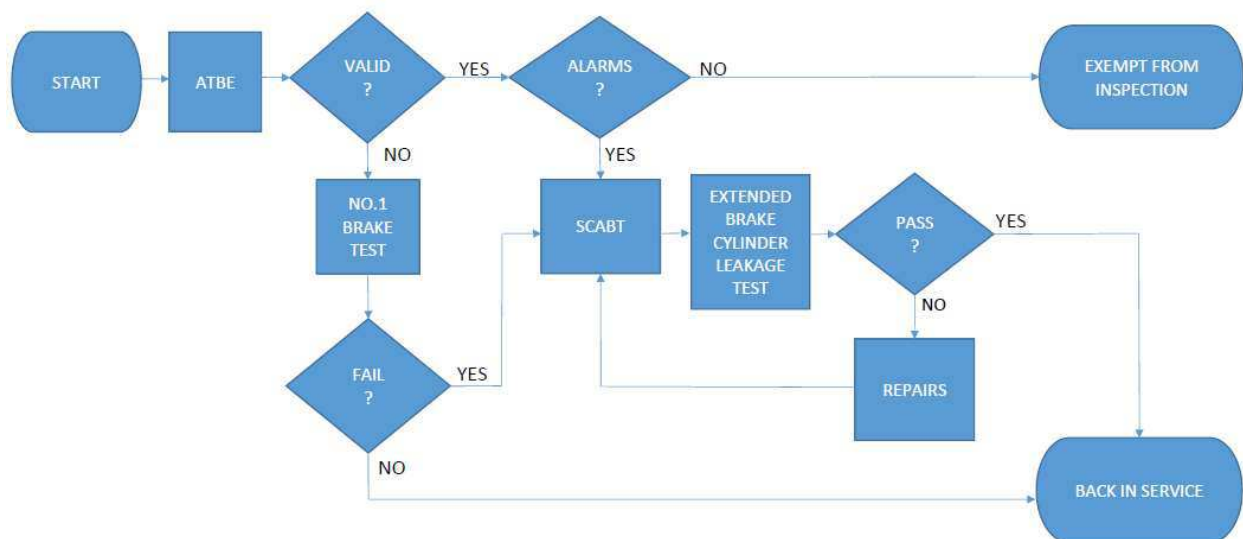
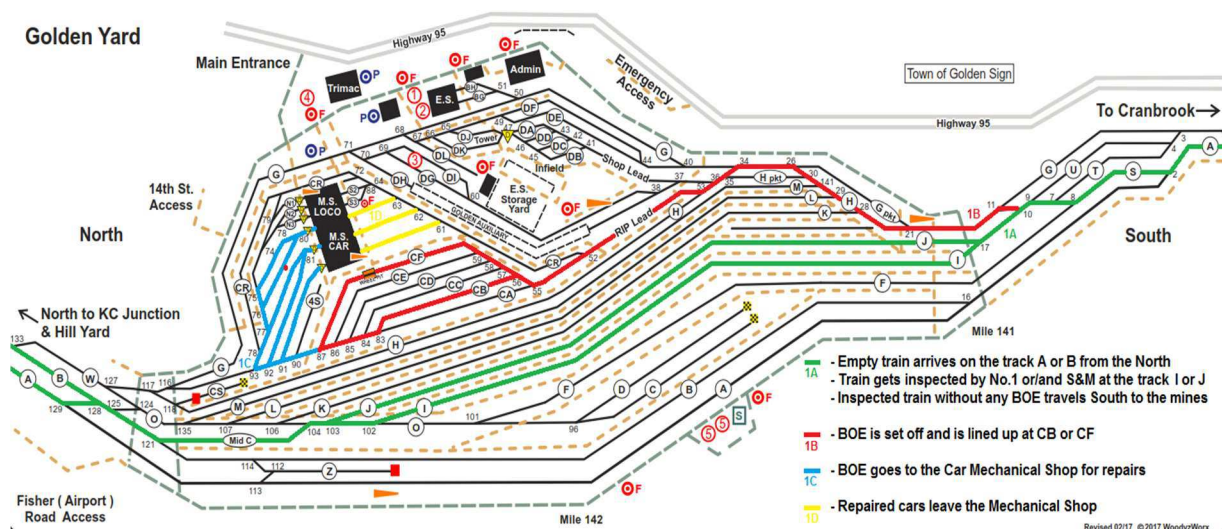

**Figure 8. Inspection and Maintenance Process following ATBE in BC Coal Loop**

Southbound empty trains arrive at the Golden Yard (Figure 9) via track A or B (1A) and into tracks I or J (1A). An S&M inspection may be performed. S&Ms are done every second cycle on the Coal loop. Trains with invalid ATBE will also have the No. 1 Brake Test done. This may be performed

prior to or after switching railcars. Once all inspections and/or No. 1 Brake Tests are done, and switching is completed, the train proceeds southward back onto A track and south towards Cranbrook to the mines. Railcars which fail the No. 1 or have any other defects are set off and switched into the track CB or CF (1B).

Railcars which fail at HW or CW detection sites have their status updated in CRB and are marked as Bad Order when Empty (BOE). Planners in the yard are notified about alarmed railcars and they have them removed from the train and switched into track CB or CF (1B in Figure 9) (Bafaro, 2017). This occurs when the railcars are empty to ensure customer shipment delays are not incurred.



**Figure 9. Golden Yard Map**

Modified from (Canadian Pacific & WoodyzWorx, 2017)

Then the BOE railcars are moved to the Mechanical shop (Figure 9), where they receive a SCABT together with an Extended Cylinder Leakage Test. Based on the results of the SCABT and visual inspection, railcars are repaired. Repaired railcars leave the Mechanical Shop (1D) and are switched to the trains as needed.

## 4 Comparative Assessment of Manual and Automated Air Brake Inspection

This chapter presents the reliability study of the manual/visual No. 1 Brake Test and the reliability of the ATBE process. Furthermore, a comparative assessment of both the manual and automated air brake fault detection methods is performed. Lastly, results of a small-scale case study performed on the grain fleet are presented.

### 4.1 Coal Fleet

The coal fleet operating in BC is currently the only fleet for which CP has been granted an exception to use WTDs to assess train brakes as an alternative to the manual/visual No. 1 Brake Test inspection. Moreover, a previous equivalence study between the No. 1 Brake Test and ATBE has been performed during a parallel process in the initial implementation of ATBE—results have been published in *Automated Train Brake Effectiveness (ATBE) Test Process at Canadian Pacific (Aronian, Jamieson, & Wachs, K., 2012)*. Therefore, this fleet is used as a benchmark for the study. Study of the ATBE process reliability is performed on historical data from 2015 to 2017. In the given years, focus has been on investigating the difference between the validity and accuracy rates in the winter and summer months.

Figure 10 depicts the ratio of alarmed railcars with CW per total coal trains with valid ATBE. In the winter of 2015, the ratio was 1.09 railcars with CW per train with valid ATBE. The ratio has been decreasing every season, and in summer of 2016 the value was 0.49. However, in the following season the ration increased again to 1.15. Between the winter of 2015 until the summer of 2016, the rate of alarmed railcars has been decreasing while the total number of trains has been increasing. This suggests the health of the coal fleet is improving. The differences in the

trends of all parameters in the 2017 winter are yet to be investigated, but it is hypothesized by the industry that fleet health is cyclical (Mulligan, 2017).

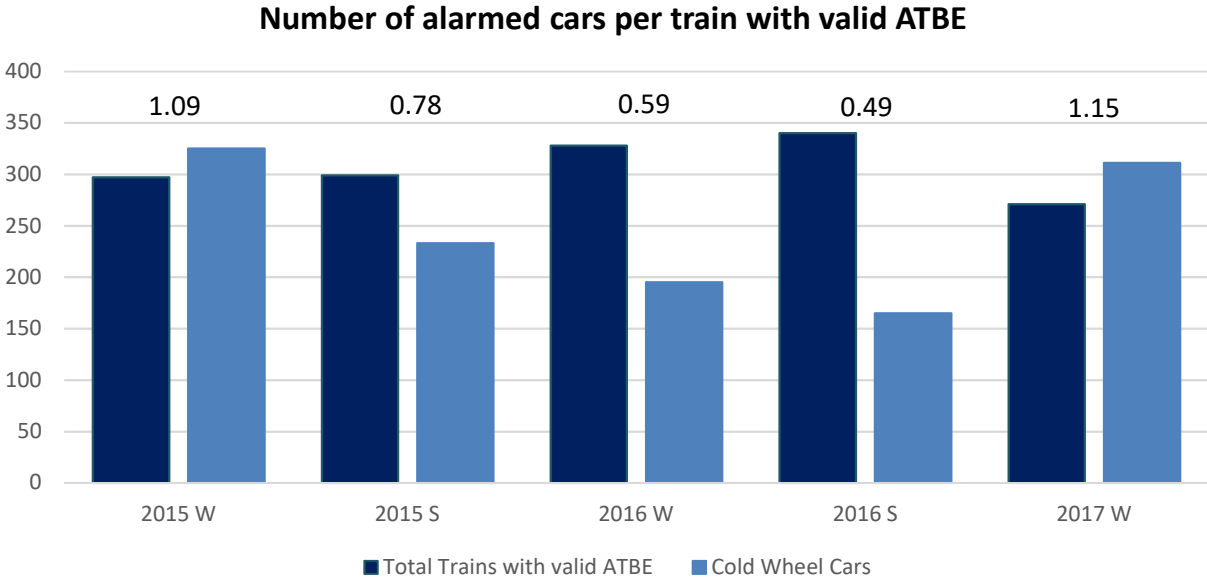

**Figure 10. Alarmed railcars per train**

4.1.1 ATBE Validity

The trains which reached train average temperatures of 180°F (82°C) on at least one of two CW detection sites, had valid automated inspection reports on at least one HW detection site, and had a TDTI report published are considered to have a *valid ATBE*. Figure 11 shows the percentage of trains passing over detection sites with successful ATBE. The results are based on the passing of all trains during the periods of interest. These numbers are based on the CP’s spreadsheet monitoring the ATBE process where each train which completed a cycle from the Golden yard through the mines to the Pacific coast and back to Golden is considered to be a unique train.



Validity rate shown in Figure 11 follows the trend of validity rates from winter of 2011 to the summer of 2014 published in *Update on Technology Driven Train Inspections at Canadian Pacific* (Jamieson, & Aronian, 2014) where during the warmer months the rate is on average above 80%. During the winter months, however, the validity of the ATBE tends to decrease, but the overall trend is upward. Lower validity rates impact the rate of B/O railcars and the maintenance rates due to lower detection rates of the manual No. 1 Brake Test inspection (*Further discussed in the section 4.3.1*). Furthermore, train cycle times increase as more trains require manual inspections (fewer are exempt due to ATBE).

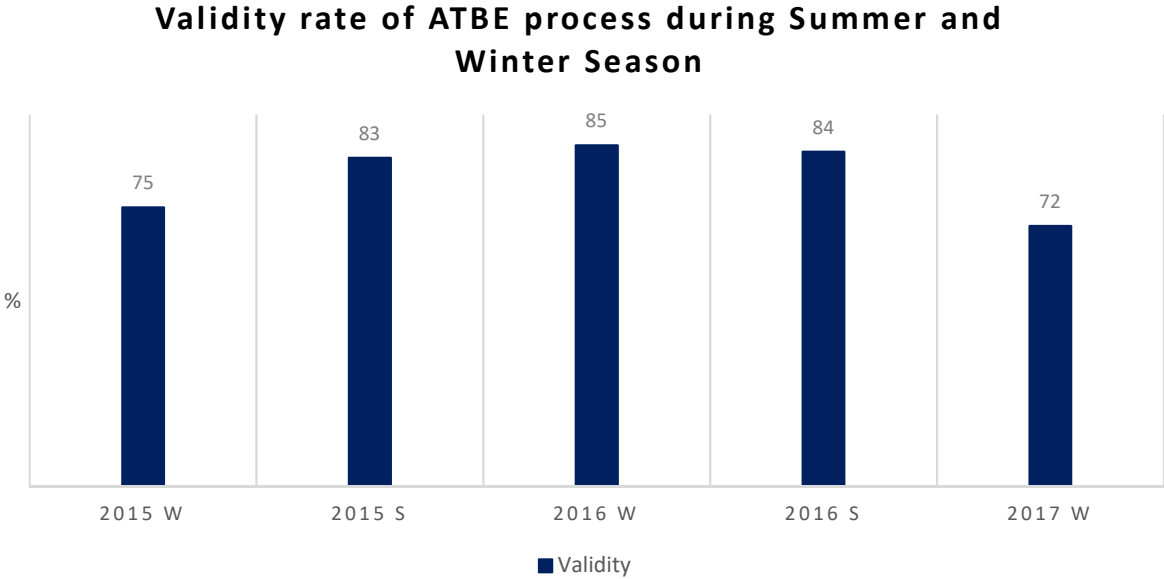

**Figure 11. ATBE validity rate**

Adapted from (Canadian Pacific, 2017)

#### 4.1.2 ATBE Reliability

*Reliability* of the ATBE process has been established in two phases, first to determine *True Positive* rate (TP) and second to determine the *Total Repair* rate (TRR). The TP rate also called sensitivity, is the rate of defective railcars correctly identified as such. In this study, this rate is based on the Valid Repair list. Valid repair is a combination of Car Components and Why Made codes from the AAR Field Manual assigned to repairs related to defects which result in ineffective brakes and therefore cold wheel alarms. Rates are calculated as follows:

1. Collect TDTI with CW alarms,
2. Randomly select sample of railcars,
3. Cross-check maintenance records of an alarmed railcars against valid repair list,
4. Collect SCABT records, and
5. Follow up the railcar for 3 months to determine Repetitive Bad Order Equipment rate (R BOE) and TRR.

TRR is calculated to account for maintenance quality. The railcars which are alarmed in one cycle and have no valid repairs done are considered to be false positives. However, if these railcars received an alarm again in the follow-up period are R BOE, and if they have a valid repair, then they are accounted for in the TRR. Figure 12 shows the percentage of railcars which have received alarms in the consecutive trips and have air brake related repairs. The difference between TRR and TP ( $TRR - TP$ ) indicates that in some cases it is necessary to spend more time inspecting a railcar and looking for a defect which is not observed easily. Due to the captive nature of the fleet, most of the railcars have been inspected and required maintenance. Increases in the TRRs suggest that obvious defects have been repaired and it is becoming more difficult to identify issues. Moreover, the valid repair list is based only on the air brake-related repairs. However, CW

can be caused by mechanical issues such as brake beam heads or guides, worn brake shoes or brake levers, or binding brake rigging (Jamieson & Aronian, 2014).

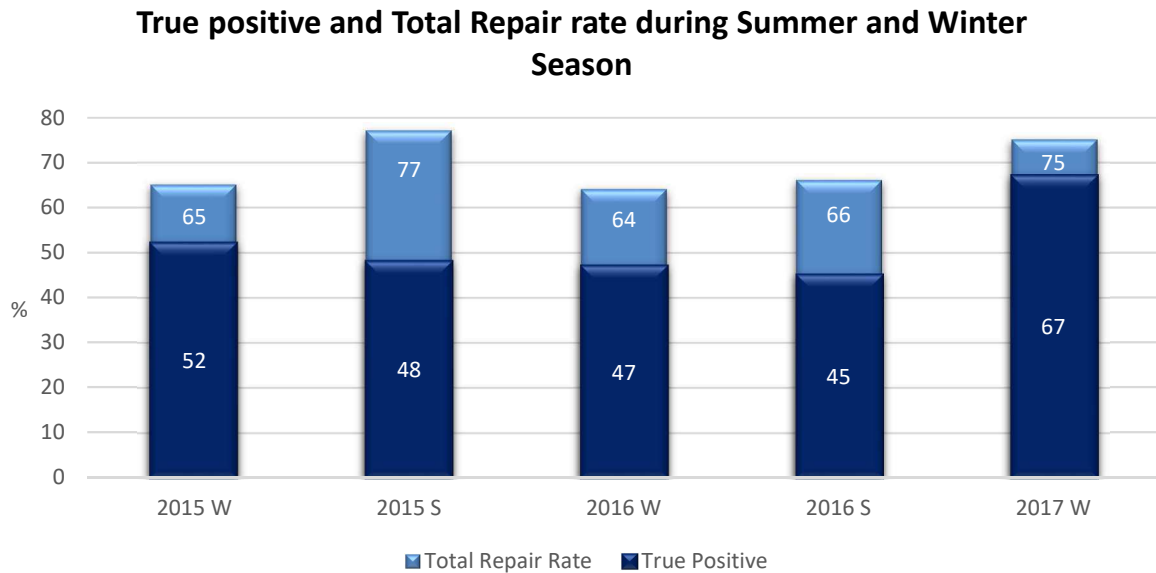

**Figure 12. ATBE accuracy and total repair rate**

Table 7 provides a list of valid repairs considered for the ATBE reliability assessment. The list has been agreed upon by TC, NRC, and CP. The list contains repairs related to air brake system defects, which cause insufficient air brake application. The table contains railcar components and qualifier codes used to log the repair in the CRB database, together with the Why Made codes. Additionally, repairs have assigned Job Codes.

**Table 7. List of valid repairs based on Car Components, Why Made and Job Codes**

Qualifiers	Car Component	Why Made						Job Codes																	
		02	03	06	15	09		1424	1428	1140	1440	1444	1448	1454	1456	1476	1480	1484	1488	1490	1498	1500			
AA	Air Brake Cylinder	02	03	06	15	09																			
AB	Air Brake Cylinder Push Rod	01	02	03	6																				
AC	Air Brake Emergency Portion	02	03	08	12	15																			
AI	Empty Load Device	02	03	12	15	08	9																		
AJ	Air Brake Reservoir	02	03	15	9																				
AK	Air Brake Service Portion	02	03	08	12	15																			
AL	Air Brake Valve	02	03	08	12	15																			
AW	Brake Beam	01	02	03	05	08	18	40	41																
AX	Brake Beam Cylinder Hose	01	02	03	04	15	8																		
AY	Brake Beam Cylinder Push Rod	01	02	03	06																				
AZ	Brake Beam Mounted Cylinder	02	03	15	9																				
BD	Brake Pin	01	02	03																					
BH	Connecting Rod	01	02	03	05	06	45																		
BJ	Cutout Cock	01	02	03	15																				
BK	Cylinder Lever	01	02	03	05	06																			
BL	Cylinder Lever Guide	01	02	03	05	06																			
BM	Dead Lever Anchor	01	02	03	05	06																			
BN	Dead Lever Fulcrum	01	02	03	05	06																			
BP	Dead Lever Fulcrum Bracket	01	02	03	05	06																			
BQ	Dirt Collector	02	03	15																					
BR	Dirt Collector & Cutout Cock	01	02	03	08	15																			
BS	Floating Lever	01	02	03	05	06																			
BT	Floating Lever Fulcrum	01	02	03	05	06																			
BU	Floating Lever Guide	01	02	03	05	06																			
BV	Fulcrum Brackets	01	02	03	05	06																			
CV	Quick Service Valve	02	03	12	15	9																			
CW	Reduction Relay Valve	02	03	12	15																				
DD	Slack Adjuster	01	02	03	08	12																			
DE	Slack Adjuster Actuating Rod	01	02	03	05	06																			
DF	Top Rod	01	02	03	05	06																			
DG	Truck Dead Lever	01	02	03	05	06																			
DH	Truck Live Lever	01	02	03	05	06																			
DK	Auxiliary Reservoir Pipe (3/4 Inch)	01	02	03	05	06	15	8																	
DL	Brake Cylinder Pipe (3/4 Inch)	01	02	03	05	06	15	8																	
DM/DR	Branch Pipe (1-1.25 Inch)	01	02	03	05	06	15	8																	
DT	Branch Pipe Tee	01	02	03	15																				
DU	Emergency Reservoir Pipe (3/4 Inch)	01	02	03	05	06	15	8																	
FL	Brake Beam Wear Plate	01	02	03	8																				
ZA	Adjustment required	28																							
ZA	Undefined Brake Equipment	01	02	03	15																				
ZC	Undefined Truck Components	28																							

Maintenance records of the alarmed railcars in the CRB database show that 49% of the repairs on CW railcars represent control valve portions, specifically, the service and emergency portions. Air brake defects causing CW which are not visible (i.e. air leakage) during the No. 1 Brake Test account for 85% of all the valid repairs. These hard-to-see defects are marked by a star in Figure 13.

### Air Brake Repairs on Cold Wheel Cars

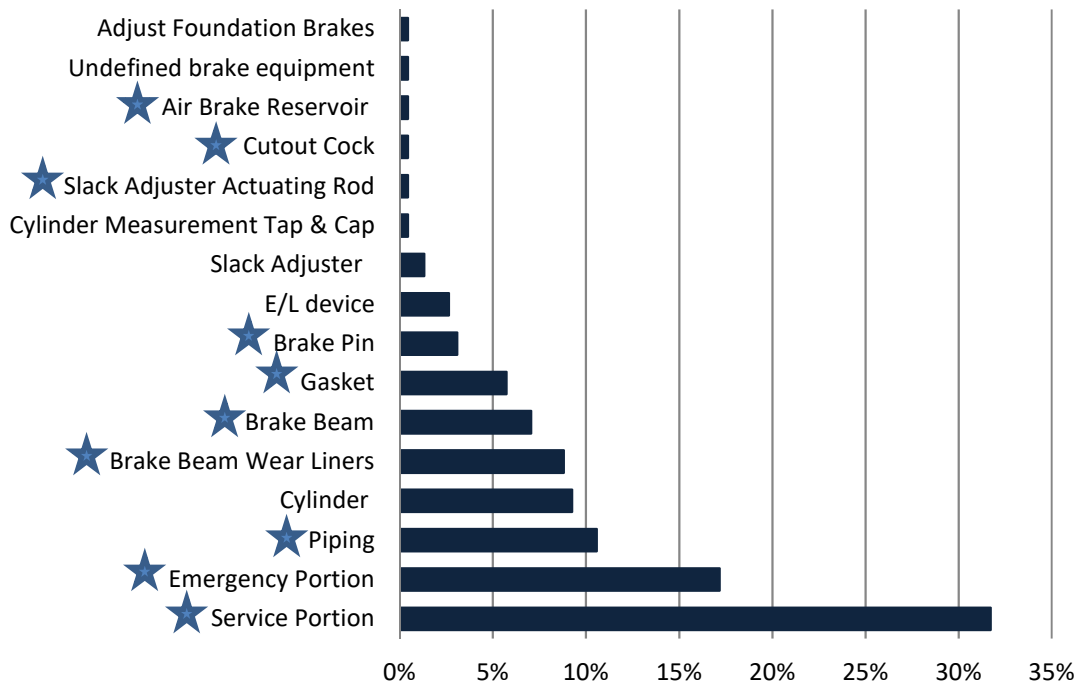

**Figure 13. Valid Repairs**

Figure 14 shows wheel temperature trending of the left side wheels on three detection sites, over 3 Coal loop cycles. Right side temperature readings are not shown because there are no cold wheel alarms. The first cycle is one cycle prior to the cold wheel alarm. During the second cycle, the railcar receives CW alarms due to the low temperatures of the third and fourth wheels on the left side (L3 and L4). The third cycle shows an increase in the temperatures after the railcar has the air brake cylinder repaired. While the L4 wheel had low temperature when passing the first detection site on Mile Post 95.1, over the detector at Mile Post 111.7, its temperature is within the same range as the rest of the wheels.

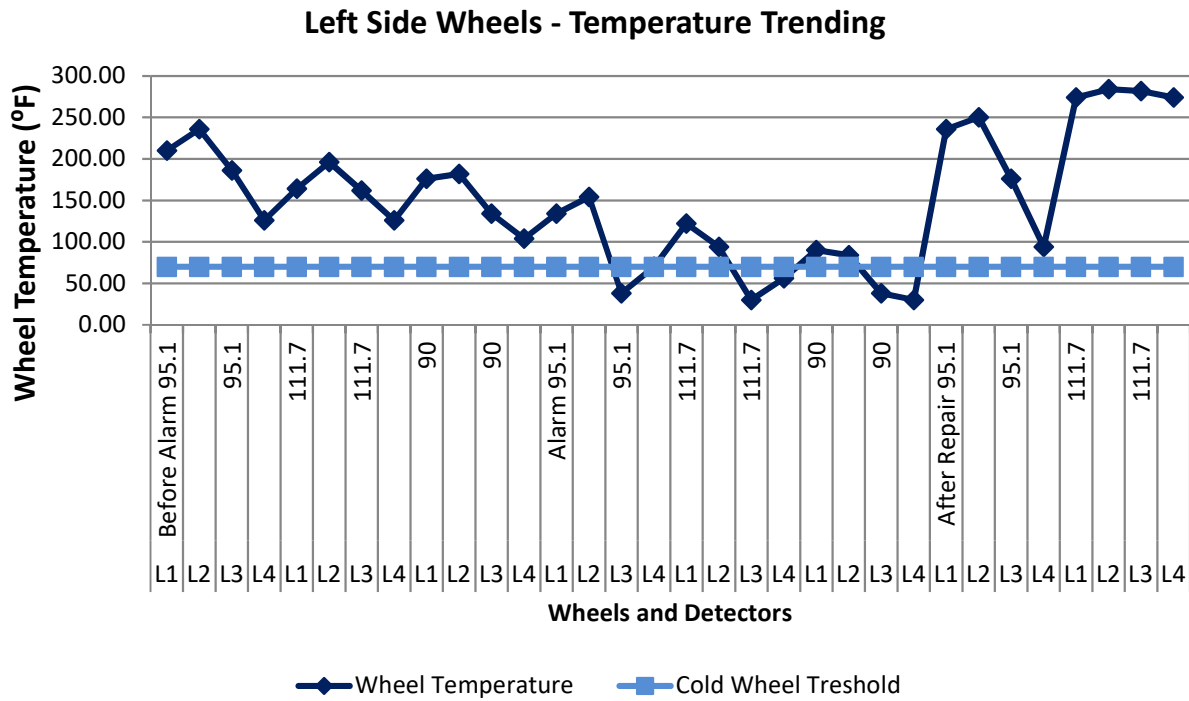

**Figure 14. Wheel Temperature Trending**

Table 8 shows the proportion of the ATBE alarms triggered per trains, railcars, and wheels. From 101 coal trains 25% have at least one railcar which fails the ATBE. A small portion of the railcars (0.19%) have air brake system issues and only 0.05% of all wheels are alarmed.

**Table 8. ATBE alarms per 101 coal trains**

	Train	Railcar	Wheel
Total passing	101	15 356	122 848
Alarmed	25	29	60
Alarmed/Total (%)	25	0.19	0.05

(Adapted from: CP Algorithm Applied to Unit Trains at Mountain MP 111.7 (National Research Council Canada, 2016))

## **Cut Out Cars**

In the case when railcars receive a HW alarm, the crew has to stop the train and verify the alarm. If an applied hand brake caused the hot wheel alarm, the crew releases it and records the incident on the brake status form. However, in the case when the hot wheel is not caused by a hand brake, but some other reason and the crew is not able to fix the problem en route, they have to cut the brakes out to isolate the control valve and to prevent further use of the specific railcars air brakes for the rest of the cycle. The train crew has to ensure the compliance of their train with the regulatory Train Brake Rules. Table 9 shows wheel temperatures of a railcar which received a HW alarm at a HW detection site Windermere 123.3 and after the crew cut the brakes out, the same railcar received a CW alarm at the CW detection site at the mile post Mountain 111.7. This enables the railcar to be flagged in the CRB for further attention by a railcar mechanic.

The analysis on a sample of 30 railcars with air brakes cut out showed that all of them received CW alarms, therefore, ATBE is able to identify railcars with completely inoperative brakes with 100% accuracy. The same results have been concluded by Liu, et al., (2017) and by Robeda, Sammon, & Madrill (2013). Robeda et al. conducted control testing at the Facility for Accelerated Service Testing (FAST) of the Transportation Technology Center, Inc. (TTCI). As an evaluation method for the WTD based inspection, control railcars of a fully loaded train with brakes cut out are used. WTDs are able to clearly identify ineffective brakes in all railcars (Robeda, Sammon, & Madrill, 2013).

**Table 9. Cut out car temperatures**

Date	ATBE Rule	Detection Site	MP	Train Average (°F)*	Wheel Location	Wheel Temperature (°F)*	Wheel Sigma	Car Average (°F)*
05/05/2017	HW	Windermere	123.3	30.6	L1	532	12.7	553
05/05/2017	HW	Windermere	123.3	30.6	L2	454	10.8	553
05/05/2017	HW	Windermere	123.3	30.6	L3	564	13.6	553
05/05/2017	HW	Windermere	123.3	30.6	L4	497	11.0	553
05/05/2017	HW	Windermere	123.3	30.6	R1	546	10.8	553
05/05/2017	HW	Windermere	123.3	30.6	R2	716	14.4	553
05/05/2017	HW	Windermere	123.3	30.6	R3	504	9.9	553
05/05/2017	HW	Windermere	123.3	30.6	R4	644	12.9	553
06/05/2017	CW	Mountain	111.7	199.9	L1	62	-3.3	42.5
06/05/2017	CW	Mountain	111.7	199.9	L2	24	-4.1	42.5
06/05/2017	CW	Mountain	111.7	199.9	L3	30	-4.0	42.5
06/05/2017	CW	Mountain	111.7	199.9	L4	56	-3.4	42.5
06/05/2017	CW	Mountain	111.7	199.9	R1	44	-3.4	42.5
06/05/2017	CW	Mountain	111.7	199.9	R2	38	-3.6	42.5
06/05/2017	CW	Mountain	111.7	199.9	R3	30	-3.8	42.5
06/05/2017	CW	Mountain	111.7	199.9	R4	56	-3.2	42.5

\*Converse to SI units using *Units conversion table*

Figure 15 shows the railcar average temperature of a coal train where two railcars have their brakes cut out. Railcar 8 has the railcar average temperature of 39.5°F (4.2°C) and railcar 12 with average temperature of 41°F (5°C). These railcars receive first a HW alarm, then are cut out, and then receive a CW alarm.



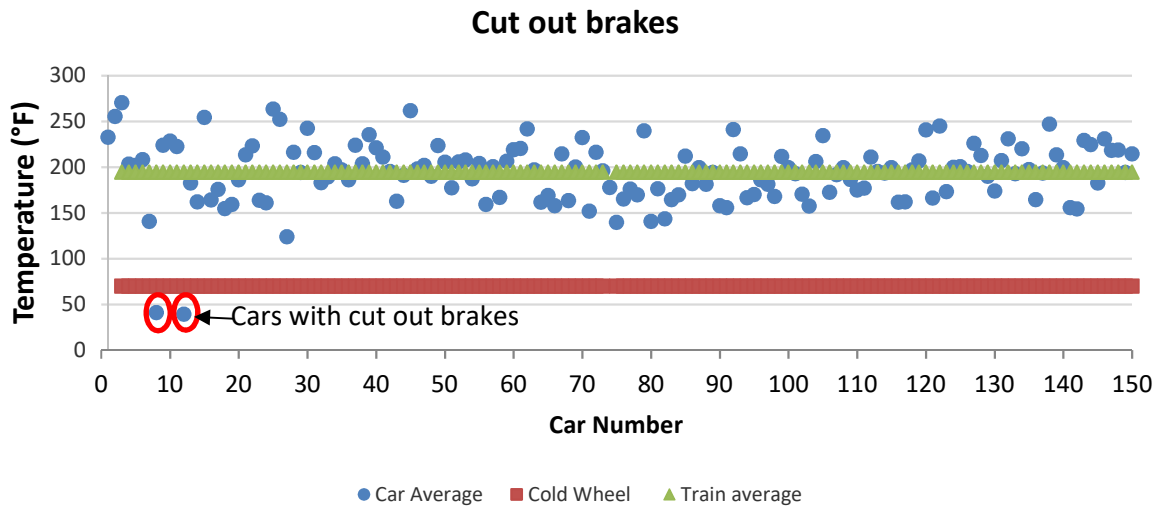

**Figure 15. Cut out brakes railcar temperature**

#### 4.1.3 No Defect Found

Study of alarmed railcars from a 2017 sample with NDF shows that 48% have only a single cold wheel alarmed. While the majority of the railcars are equipped with the BMB systems, the coal fleet has 48% more railcars with a BMB system than a TMB system. Figure 16 shows normalized values of the NDF railcars over the total number of railcars with BMB and TMB configurations in the whole fleet.

shows temperature trending of multiple wheels on multiple railcars which are flagged as cold. The graph shows temperature trending of these wheels at MP 111.7 over 5 Coal Loop cycles. Most of the wheels have very low temperatures over several cycles prior to receiving an alarm. Even though the railcars had no valid repair done and therefore are considered to be false alarms, temperatures on all of them increase after maintenance. This suggests that invalid repairs can result in increasing wheel temperatures.

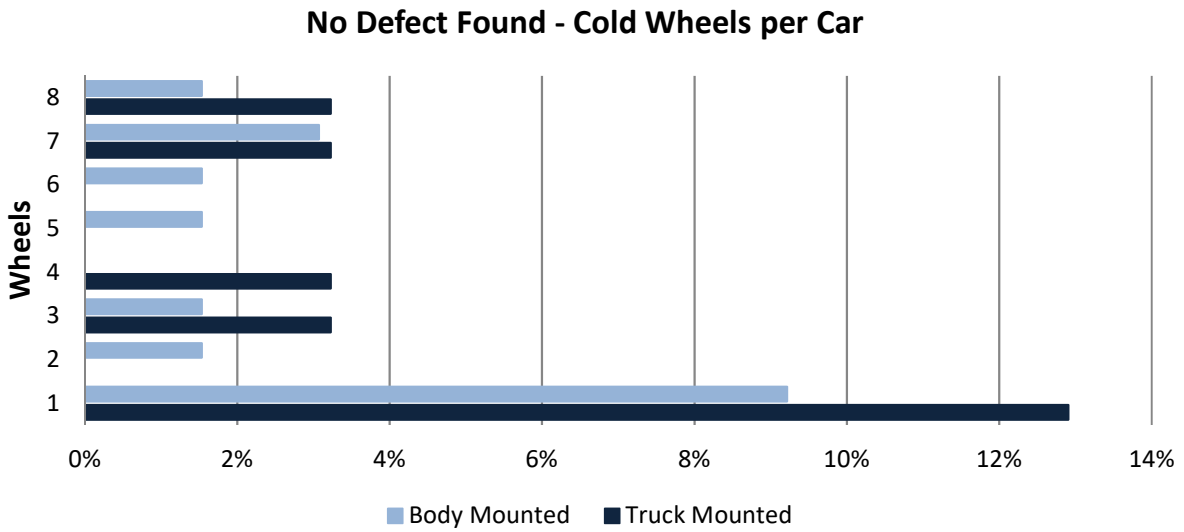

Figure 16. No Defect Found by number of cold wheels

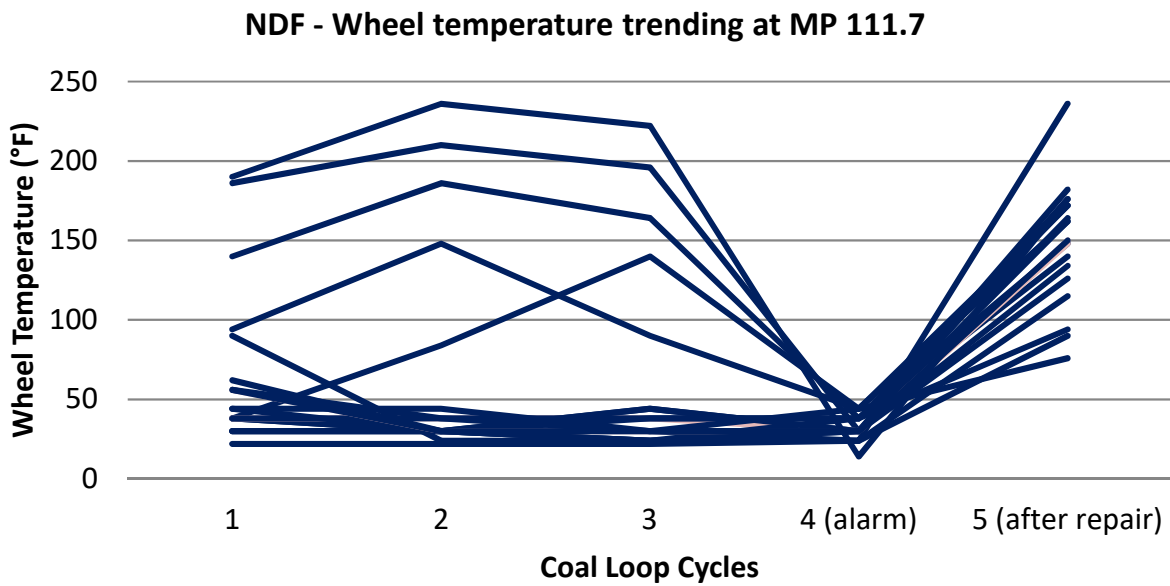
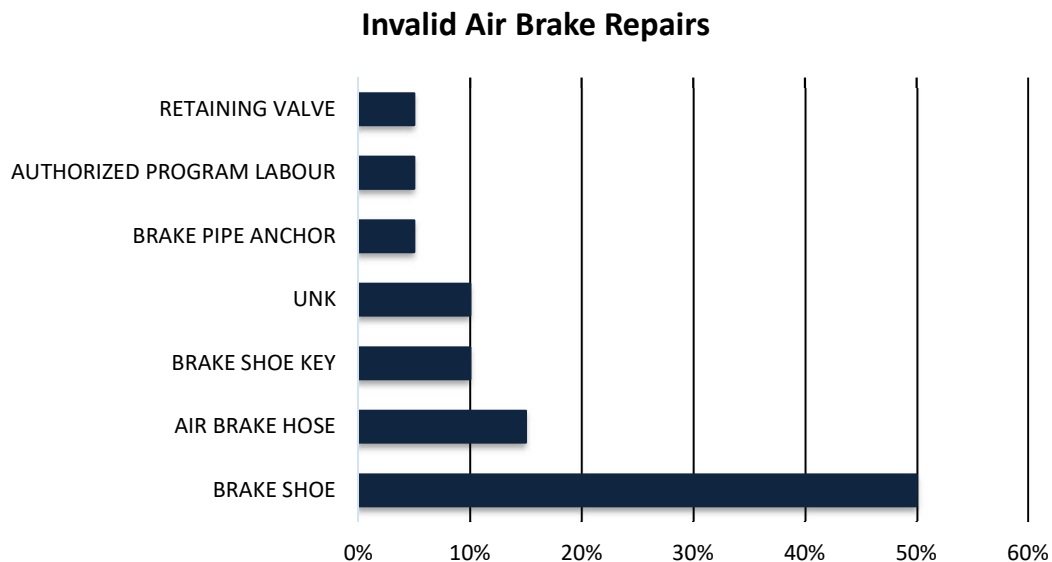

Figure 17. Temperature trending of NDF cars

Figure 18 shows that the most frequent invalid air brake repairs are brake shoe replacements which account for 50%, followed by air brake hoses with 15%.



**Figure 18. Other Brake System Repairs**

A sample of 60 railcars with CW alarms in the 2017 winter season is analyzed. The maintenance records show that only 2 railcars, which did not have either valid repairs nor repetitive alarms, are false alarms. The rest of the railcars have either valid repairs (Figure 13), invalid brake system repairs (Figure 18), or other mechanical repairs. The most frequent (Figure 19) not air brake related repairs are coupler knuckles (39%), wheels (19%) and roller bearings (18%). Failure of any of these components could seriously impact rail safety and rail operations. Brake and Chiu, performed a study of how many derailments are avoided due to the use of wayside detection technology. They conclude that the components most responsible for derailments are wheels (45%), brakes (33%), and couplers (21%) (Brake & Chiu, 2005). Since 2011, when the ATBE was implemented, there were no coal railcars derailed (Mulligan, 2017).

Overall 77% of railcars have brake-system-related repairs, either valid, invalid, or a combination of the two. Additionally, 20% of railcars have only mechanical repairs, which are not identified by any other inspection performed by the railcar mechanics. Only 3% of the sample are false alarms.

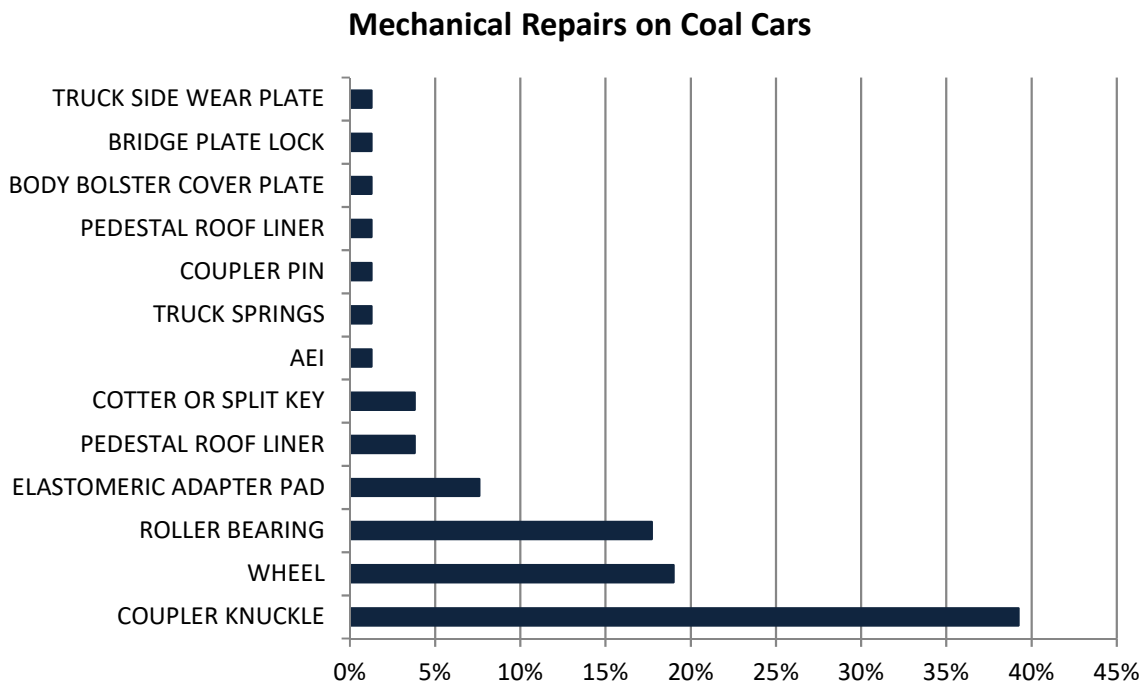

**Figure 19. Mechanical Repairs**

#### 4.1.4 No. 1 Brake Test

##### **Limitation of data**

ATBE is the primary air brake inspection method of the coal fleet; the No. 1 Brake Test is used only when the ATBE is not valid. Currently, more than 80% of the coal trains on average have valid ATBE tests and, therefore, a small number of the trains undergo the No. 1 Brake Test. When undergoing either the No.1 Brake Test or the S&M Inspection, however, trains have results of

both inspections entered onto 662 labelled forms. Railcars which fail any of the two inspections are recorded, but the information about which inspection the railcar failed is not. In turn, it is difficult to retrieve the No. 1 Brake Test data. Therefore, insufficient No. 1 Brake Test data availability and a small sample size (grain fleet) are the main limitations of this study.

### 4.3 Grain Fleet

The CP grain network spreads from coast to coast in Canada and into the Midwest USA (Canadian Pacific , 2017). In Canada, CP services grain elevators in the prairies. Prairies are western-Canadian provinces: Alberta, Saskatchewan, and Manitoba, where railcars are loaded. Loaded trains travel to the terminals at ports, where emptied trains are inspected by the No. 1 Brake Test before returning to the prairies. In comparison to the coal fleet, the grain fleet is not captive, and empty railcars are re-marshaled on different trains.

Grain fleet hopper railcars have different train average wheel temperature thresholds and standard deviation levels for cold wheel alarms. The wheel temperature threshold is the same as for the coal railcars. However, the train average temperature and standard deviations vary depending on measured temperature distributions. These thresholds are summarized in Table 10.

**Table 10. Cold wheel criteria for grain hopper railcars**

Type of Alarm	Criteria
Cold Wheel	Wheel Temperature $\leq 70^{\circ}\text{F}$ ( $21^{\circ}\text{C}$ )
	Sigma $\leq -1.5$
	Train Average Wheel Temperature $\geq 155^{\circ}\text{F}$ ( $68^{\circ}\text{C}$ )

Figure 20 shows a wheel temperature distribution of grain and coal trains. Neither of the fleet has a perfectly normal distribution, both are skewed.

## Grain & Coal Train Wheel Temperature Distribution

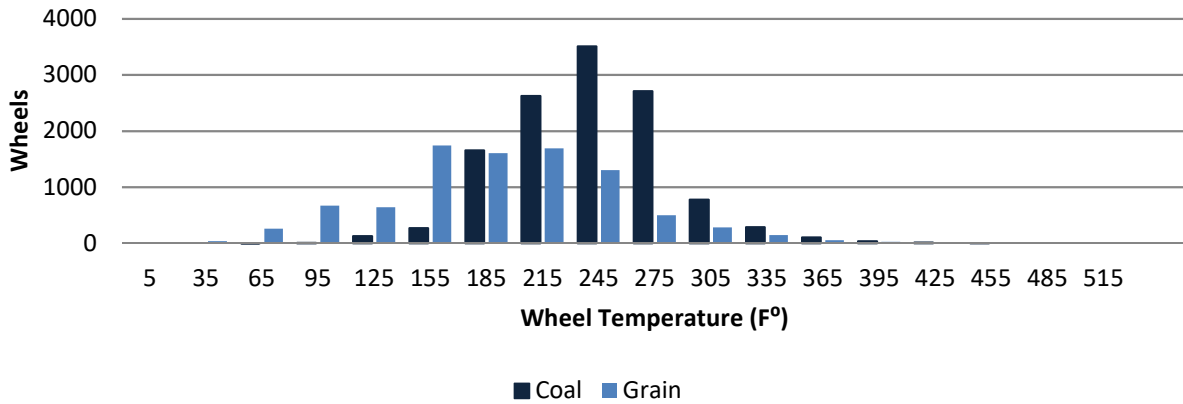

Figure 20. Wheel temperature distribution of coal and grain trains

### 4.3.1 Detection Rate

Data of the loaded westbound grain trains travelling to the terminal on the pacific coast during the period from the October 28 to November 12, 2017 are collected. The purpose is to compare the detection rate of the No. 1 Brake Test and the ATBE, that is the rate at which railcars fail air brake inspections, on the same sample of trains. The data collection and analysis process are described below.

1. Collect records of all west bound grain trains
2. Collect the ATBE temperature readings and TDTI reports
3. Collect No. 1 Brake Test results of the same trains
4. Compare detection rate between the No. 1 Brake Test and the ATBE
5. Compare if the methods identified the same railcars as defective

6. Verify if the railcars which failed the No. 1 Brake Test but passed the ATBE were trending towards a CW alarm
7. Verify if the railcars which failed the No. 1 Brake Test had valid repair

Contrary to the coal fleet, the primary air brake inspection method of the grain fleet is the No. 1 Brake Test. Therefore, only the railcars which failed the No. 1 Brake Test are bad ordered.

## **Results**

During the period of interest, 44 unique grain trains, with an average of 112 railcars per train, passed ATBE CW detection sites and the No. 1 Brake Test. ATBE detectors flagged 695 railcars as defective, while railcar mechanics during the No. 1 Brake Test flagged only 5 railcars (Table 11). The detection rate is 1:139 railcars for ATBE. There are 2 unique railcars that failed both the manual/visual inspection and automated inspection. One of them had an emergency portion replaced, the second had an emergency portion body gasket replaced—both of these repairs are valid as per previously described criteria. From 3 railcars that failed the No. 1 Brake Test, only 1 had a repair considered to be valid: pipe fitting repair. The historic wheel temperature measurements of this railcar are in the range from 174°F to 332°F (79°C to 167°C), therefore, we can assume that the observed leakage is not enough to prevent sufficient air brake application and release. As per regulation, some acceptable train line leakage is permitted during a SCABT (New York Air Brake, 2017). This case further supports the objectivity of WTD inspection systems when assessing air brake operation. Two other railcars which failed the No. 1 Brake Test have no valid repair. The only repairs these railcars have in the CRB are related to damaged reflective sheeting.

Lower detection rates of the manual/visual air brake inspection method impact the amount of B/O railcars resulting in less cars to be more thoroughly inspected for mechanical defects and SCABT testing. A high B/O rate has a positive impact on rail safety and improving the health and reliability of the railcars. Moreover, it decreases yard dwell by removing the component of the long manual inspection performed by railcar mechanics. On the other hand, it increases mechanical shop dwell by shopping more railcars, which leads to the higher down time and a decrease in the operation effectiveness and productivity (New York Air Brake, 2017), although the railcars are shopped when empty after the service commitment is fulfilled. Quality of the maintenance is the key to ensure that the shopped railcars remain in service longer without failures and, therefore, returning to the mechanical shop for additional maintenance.

**Table 11. Comparison between the No.1 Brake Test and ATBE**

	Total	Railcar per train	Valid Repairs	Repair
Total trains	44	n/a	n/a	n/a
Railcars alarmed by the ATBE	695	695/44	n/a	n/a
Railcars alarmed by the No.1 BT	5	5/44	3/5	1x Pipe Fitting 1x Emergency portion 1x Emergency portion body gasket
Railcars failing No.1 BT & ATBE	2	2/44	2/2	1x Emergency portion 1x Emergency portion body gasket

4.3.1 Field Testing: Comparison of ATBE vs. No.1 Brake Test vs. Single Car Air Brake Test

Small-scale testing is done on covered hopper railcars in CP’s mechanical shop in Port Coquitlam. This location has been selected because grain railcars prior to arrival to Port Coquitlam pass ATBE



cold wheel detection sites and upon their arrival are emptied and undergo the No. 1 Brake Test. Moreover, ASCT devices (Figure 21) at this location enables SCABT testing before and after repairs. The team performing the test consisted of CP's railcar mechanics, air brake and reliability managers, NRC officers, and myself. The purpose of this test is to assess brake shoe force on grain railcars which failed the ATBE test, this portion of the test has been done by the NRC, and to determine if the SCABT confirms CW alarms.

For the purpose of the testing, 12 railcars alarmed by the ATBE as CW railcars and 2 baseline railcars with no alarm are selected. Out of 14 railcars, two railcars (car number 1 and 3) have body-mounted brakes, and the rest have truck-mounted brakes.

If possible to charge the railcar air brake system, Brake Shoe tests are performed. Then at the beginning of the SCABT, a soap-and-bubble test (by applying glass cleaner on the air brake system to detect any leakages) is performed. When a railcar fails the SCABT, mechanics disconnect the ASCTD and proceed with repairs. All repairs are recorded on a ATBE Shop Repair Details form. Later, these repairs are entered in to the CRB database. After the repairs are completed, ASCTD devices are again connected to the railcar through the end of the railcar (Figure 21) and the railcar is re-tested. If a railcar fails the test, further inspection and repairs are performed. If railcar passes the SCABT and Extended Leakage Test, brake shoe forces are re-measured.

**Test process:**

1. Bad Order grain railcars with cold wheels upon their arrival in Port Coquitlam and select two baseline railcars
2. Perform Brake Shoe test
3. Perform SCABT and Soap-and-bubble Test
4. Repair railcars
5. Perform SCABT – a railcar has to pass the test, if not, repair and re-test

6. Record all repairs
7. Brake Shoe test.

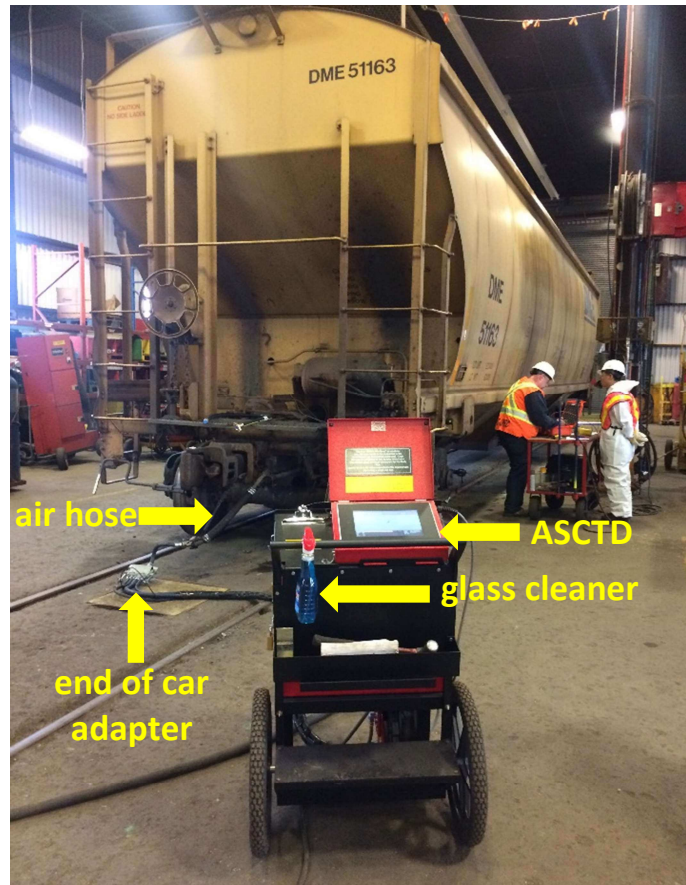

**Figure 21. SCABT test set up**

(Photo by author)

### **Findings**

As shown in Table 12, all railcars passed the No. 1 Brake Test before departure from the SIL. Later, when passing detectors, all of them fail the automated inspection, except the baseline cars. ATBE CW alarms are confirmed by the ASCAT device. The baseline railcars (numbers 5 and 6) both passed the SCABT, but still required minor repairs as a result of additional items identified by the

SCABT and the mechanical inspection requirements prior to shop release. Railcar number 5 specifically required an air brake hose replacement and railcar number 6 failed the Retainer Leakage portion of the SCABT. Neither the Air Brake hose nor the Retainer valve are valid repairs. After repair of all the defects, all railcars passed the SCABT test.

**Table 12. Small-scale testing results**

Car number	No.1	ATBE	SCABT
1	Pass	Fail	Fail
2	Pass	Fail	Fail
3	Pass	Fail	Fail
4	Pass	Fail	Fail
5 - baseline	Pass	Pass	Pass*
6 - baseline	Pass	Pass	Pass*
7	Pass	Fail	Fail
8	Pass	Fail	Fail
9	Pass	Fail	Fail
10	Pass	Fail	Fail
11	Pass	Fail	Fail
12	Pass	Fail	Fail
13	Pass	Fail	Fail
14	Pass	Fail	Fail

\*Retainer and Air Brake Hose repairs required - invalid repairs

Figure 22 shows a wheel temperature of loaded grain hopper railcars in the Mountain subdivision when passing the wheel temperature detectors at Mile Post 95.1, when they are flagged as having a cold wheel. The baseline cars number 5 and 6 did not receive an alarm, the temperature is from their passing through the cold wheel site before being shopped in Port Coquitlam.

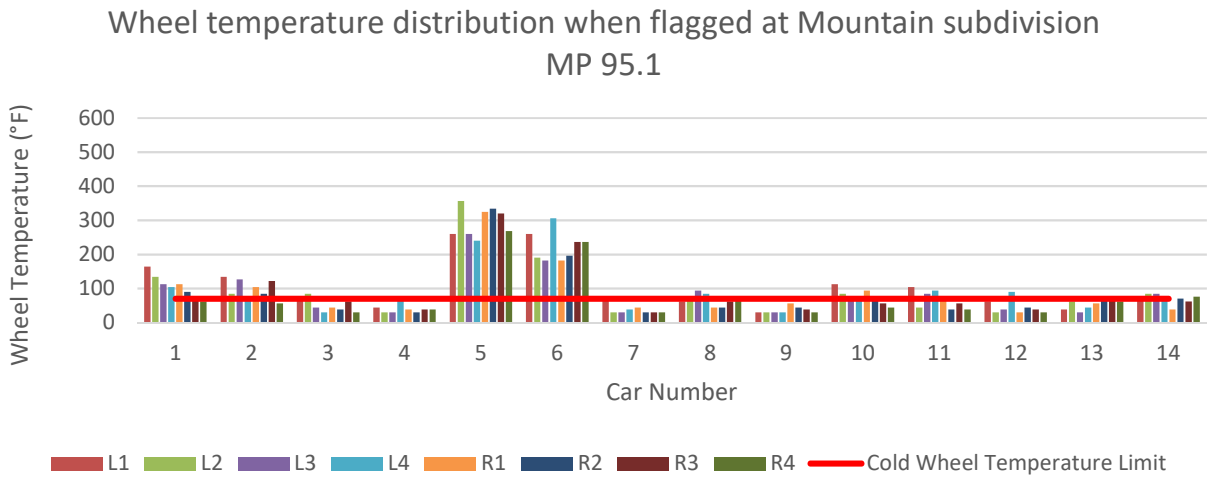

**Figure 22. Wheel temperature distribution before the repair**

Of these railcars 2 have a single cold wheel (CW) alarm, 1 has two CW, 1 has three CW, 2 have four CW, 1 has five CW, 0 have six CW, 3 have seven CW, and 2 have eight CW. All cold wheel railcars fail the first SCABT test. After repairs, all railcars pass the test.

Figure 23 shows improvement in the wheel temperatures on all repaired railcars within the first cycle after testing. On average, wheel temperatures after the repair increase by 236%.

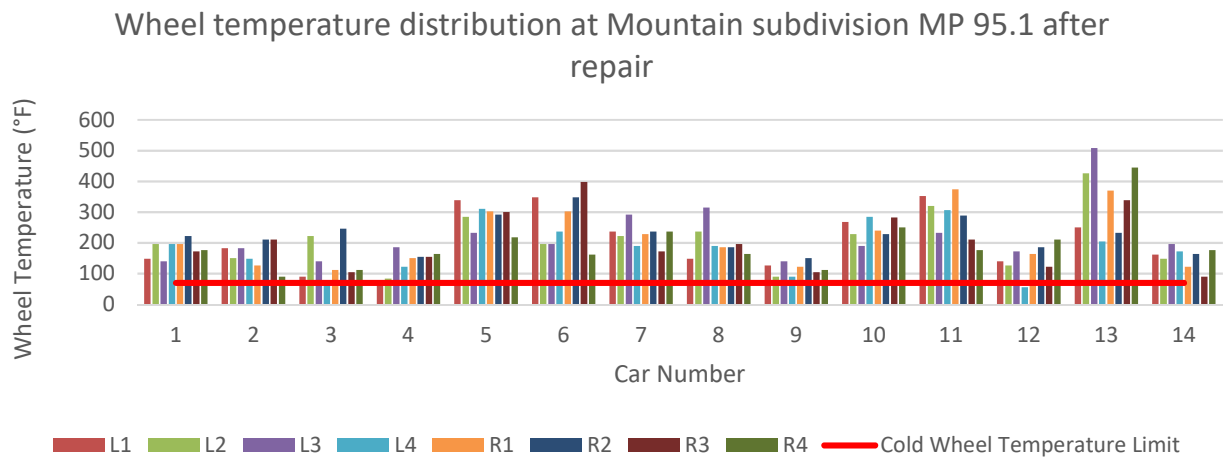

**Figure 23. Wheel temperature distribution after repair**

Figure 24, Figure 25, and Figure 26 show defects found during testing of the grain hopper railcars. Soapy solution application during a SCABT and soap-and-bubble test enable detection of leakages in service portions, emergency portions, gaskets, and flanges. During a thorough inspection of the railcars flagged by the ATBE in the shop, defects which are not noticed neither during the S&M inspection nor the No. 1 Brake Test are identified. Broken brake beam wear liners, pushrods not attached to brake cylinders, worn-out brake shoes causing long pistons, and extremely worn-out brake shoes damaging wheels. These defects have a direct impact on braking performance because they decrease the applied brake force and therefore cause ineffective braking and cold wheels. For example, the air brakes on the railcars no. 7, 9, 12, and 13 cannot be charged during the test due to bent air brake release rods or severe air brake hose leakages releasing air from the brake system.

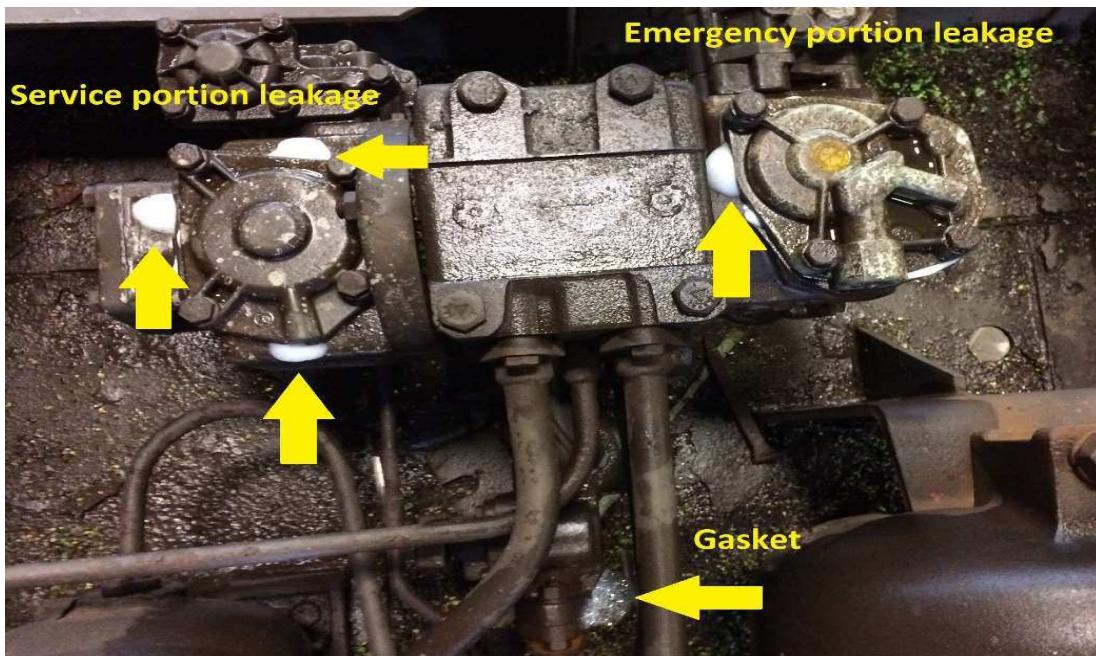

**Figure 24. Leakage detected during the SCABT test**

(Photo by author)



**Figure 25. Worn out brake shoes**  
(Canadian Pacific, 2017)



**Figure 26. Grain Hopper Railcar Defects (multiple railcars)**  
(Canadian Pacific, 2017) & (Photos by author)

Table 13 summarizes the number of CWs detected by the ATBE process and the repairs performed on tested railcars. The most frequent valid defect, found on 10 inspected railcars, is gasket leakage. From invalid repairs, 8 out of 14 railcars have brake shoes below condemnable limits which require replacement.

**Table 13. Repairs and cold wheels**

Car number	# Cold Wheels	Service Portion	Emergency Portion	Gasket	Brake Beam Wear Liner	Brake Cylinder	Slack Adjuster	Other
1	3			x				-brake shoe -retaining valve
2	2	x		x				-brake pipe -brake shoe -retaining valve
3	7			x				-brake pipe
4	8	x		x				-brake shoe -retaining valve
5 - baseline	0							-air brake hose
6 - baseline	0							-brake pipe -brake shoe -retaining valve
7	7	x		x	x	x		-pushrod -retaining valve -brake shoe -air brake hose
8	4			x		x	x	-brake shoe -retaining valve
9	1	x		x		x		-brake shoe -air brake hose
10	4		x	x		x		-air brake hose
11	7			x				-brake shoe -air brake hose
12	8			x				-auxiliary reservoir pipe
13	1							-brake shoe -air brake release rod
14	5	x	x					-empty load device -retaining valve -air brake hose

#### 4.4 Comparative Assessment

A comparative assessment of two North American freight railcar air brake inspection methods to evaluate the performance of an automated condition monitoring system compared to manual/visual inspections has been performed (Table 14). The reliability assessment of both inspections is based on the maintenance with latency. Maintenance records of railcars which fail either of the inspections has been compared against the list of valid repairs (Table 7). The main difference between the methods is obvious; one is performed by humans (railcar mechanics), the second is technology-based. Quality of the manual inspection depends on railcar mechanic experience and impact of the working environment on human factors. Quality of automated inspection is also affected by the technology reliability in harsh environmental conditions. The limitations of the No. 1 Brake Test are discussed in *section 2.2.1* and limitations of the TDTI in *section 2.2.3*.

The key reason why the ATBE process enhances rail safety is the frequency of the inspection and the high detection rate. As both inspection methods help identify defects which are not related to the braking system, the method which bad orders more railcars (which are then inspected and tested in the shop) is preferred from a safety point of view. Additionally, ATBE test is able to identify defects which cannot be seen during visual inspection (Aronian, Wachs, Jamieson, Carriere, & Gaughan, 2012)(Jamieson & Aronian, 2014) (Robeda, 2011):

- partially-released hand brakes,
- worn/damaged brake beam wear guides,
- small leaks in brake cylinders, reducing pressure over extended time interval,
- faulty slack adjusters, and
- ability to recognise between brakes applied and non-applied in known and unknown braking conditions.



**Table 14. Comparative Assessment**

Category	Manual Inspection	Automated Inspection
Performer	Human	Technology
Tools	Visual	<ul style="list-style-type: none"> <li>• Detectors - Pyrometer</li> <li>• Server</li> </ul>
Objectivity	Subjective	Objective
Controlled by	Regulations and Guideline	Validation and Alarm Rules
Conditions	Static, Low Speed	Dynamic, Track Speed
Air Brake Application	Full Service (26 psi)	8 - 15 psi
Duration of Air Brake Applications	14-16 minutes	3-8 minutes 17-30 minutes
Data	Handwritten	Electronic
Records	Paper, Electronic	Electronic
Data Availability	After call to a planner	Almost real-time
# of inspections/cycle	1 in Golden	4 sites
Inspection points	<ul style="list-style-type: none"> <li>• the integrity and continuity of the brake pipe</li> <li>• the condition of the brake rigging on each railcar</li> <li>• the application and release of the brakes on each railcar</li> <li>• the piston travel on each railcar is within the specified limits</li> </ul>	<ul style="list-style-type: none"> <li>• hot wheel (&gt; 200°F (93°C)) – the release of the brake</li> <li>• cold wheel (&lt; 70°F (21°C)) – the application of the brake</li> </ul>
Length of the process	90 minutes	During train passing
Factors impacting quality	Human	Data transfer, AEI
Tools Calibration	90 days Cost of the calibration	Monthly
Cost	<ul style="list-style-type: none"> <li>• (\$120 labour/ hour x 2 persons) @ 90 minutes = \$360</li> <li>• Train delay \$5000/hour @ 90 minutes = \$7500</li> <li>• Total = \$7860/inspection</li> </ul>	<ul style="list-style-type: none"> <li>• Technology and algorithm development (fixed cost)</li> <li>• Maintenance \$20 000/year</li> </ul>
Safety	100%	100%
Risk	low	low
Detection Rate Ratio	1:139	

#### 4.5 Enhanced ATBE Reliability – Multiple Cold Wheels & Multiple Detectors Hit Rules

The ATBE TP rate in the Winter of 2017 is 66% and TRR is 75 %—these are the results achieved with the current ATBE process alarm rules which require at least one wheel on railcars to be flagged as CW by at least one of the detectors. Efforts have been made to improve ATBE air brake defects detection reliability, one of which is sequential detectors study. To the current ATBE CW detection sites on the CP's Mountain subdivision at Mile Posts 95.1 and 111.7, the detector on the Shuswap subdivision located west of the Mountain subdivision, at Mile Post 90, has been added to the sequence for the purpose of this study. The Shuswap detection site is located at the bottom of a 10-mile-long grade with gradient of 1%. Due to gradient of less than one on the Mountain subdivision, train speed control requires fewer air brake applications and therefore, trains passing this site do not reach train average temperature threshold of 180°F (82°C) as required by the ATBE CW alarm rules. The ATBE train average temperature threshold and standard deviations rules do not apply to the detection site Shuswap 90, therefore, the only criterium for CW alarms at this site is CW threshold of 70°F (21°C). This Multiple Detectors Hit Rule requires railcars to be flagged by at least 2 detectors to be B/O. Additionally, the Multiple CWs rule has been analyzed because single cold wheel railcars account for the largest portion of NDF BOE (Figure 16). Multiple CWs rule requires at least 2 wheels on one railcar to be flagged in order to trigger a CW alarm.

Reliability study of the Enhanced ATBE is performed on the same sample of 78 railcars as the TP and TRR rates of the winter in 2017 have been calculated. The reliability is based on railcars wheel temperature readings and maintenance history. Performances of Enhanced ATBE Alarm Rules are summarized in Table 15. Firstly, detection sites alarms are denoted by number 1; detectors in the sequence which did not trigger an alarm are marked by number 0. Secondly, the performance of the current ATBE CW alarm rules on the sequence of detectors is investigated. The railcars which are flagged by all three detectors have a 100% valid repairs rate. The average

reliability of multiple detectors improves current ATBE performance by 5%. The last column shows reliability rates of different detector sequences in combination with the enhanced Multiple Cold Wheel Hit Rule. In this case, railcars which have at least 2 CWs flagged by multiple detectors have a 100% TP rate. The combination of Multiple Detectors and Multiple Cold Wheels Hit Rules increases reliability of the ATBE process by 9%. By the same rate, fewer railcars would be B/O and shipped if these rules were implemented.

**Table 15. Results of enhanced ATBE on coal fleet data**

Mountain 95.1	Mountain 111.7	Shuswap 90	Current ATBE	Enhanced ATBE
			1+ Wheel	2+ Wheels
			Total Repair Rate	Total Repair Rate
1	1	1	100%	100%
0	1	1	74%	69%
1	0	1	67%	-
0	1	0	62%	80%
1	0	0	-	-
<b>TOTAL</b>			<b>75%</b>	<b>83%</b>
<b>2+ Detectors</b>			<b>80%</b>	<b>84%</b>

The current ATBE validity rate which requires trains to reach a minimum train average temperature of 180°F (82°C) on at least 1 out of 2 cold wheel detection sites in 2017 winter is 72% on average. The enhanced ATBE validity rate is calculated on a sample of 59 unique trains, which passed detectors between January and March 2017. The rate of trains which reached the minimum train average temperature of 180°F (82°C) on at least 2 out of 3 detection sites is 69%. Current ATBE shows one detector still effective to access if a train is braking, suggesting majority rule for multiple detectors, but still triggering alerts if at least one detector reports in.

## 5 Impact of Dynamic Braking on the Automated Train Brake Effectiveness Process

This chapter investigates the impact of dynamic braking on train average temperature on descending grades with air brakes applied. For this study, train handling details and wayside temperature detector measurements from cold wheel detection sites MP 95.1 and MP 111.7 on Mountain subdivision and the detector Shuswap MP 90 on CP's network are analyzed.

Locomotive downloads of 8 trains passing detectors in February and March 2017 through the Mountain and Shuswap subdivisions are analyzed. The process for analysis of dynamic braking impact is described in the following.

### 5.1 Dynamic Braking Impact Calculation Process

1. Collect Locomotive Downloads

Coal train locomotive downloads have been collected by the staff at Golden yard, BC. These files have been collected after the trains complete the BC coal loop cycle, upon arrival at Golden. Table 16 summarizes information of selected trains.

2. Process locomotive download data to get inputs for the Brake Horsepower (BHP) calculation.

To assess locomotive download data Q-Tron Universal Analysis/Download Software (QUADS) from Wabtec corp. is used. The software displays train handling data in tabular and graphical form.

**Table 16. Coal trains locomotive downloads**

Train ID	Date of passing	Date of download	ATBE status	Cold wheel	Detector alarm	Train Avg Temp 95.1 (°F)*	Train Avg Temp 111.7 (°F)*	Train Avg Temp 90 (°F)*
1	19-02-2017	22-02-2017	valid	yes	111.7	142.6	183.3	114.7
2	22-02-2017	28-02-2017	invalid	-	-	136.5	173	155.4
3	25-02-2017	28-02-2017	valid	no	-	203.6	162.8	122.3
4	25-02-2017	28-02-2017	valid	no	-	212.2	221	143.8
5	25-02-2017	28-02-2017	valid	yes	95.1&111.7	192.9	198.2	132.6
6	26-02-2017	28-02-2017	valid	yes	111.7	157.9	180.9	171.9
7	26-02-2017	01-03-2017	valid	yes	111.7	243.9	189.6	151.8
7	02-03-2017	06-03-2017	valid	yes	111.7	206.3	214.3	216

\*Converse to SI units using *Units conversion table*

Locomotive downloads contain records of train handling information, such as speed, acceleration, tractive effort, air brake and dynamic brake application, fuel level, horn application, distance, etc., of every second the locomotive is on/running.

### 3. Train Handling

Locomotive downloads are exported to spreadsheets and train handling details such as time and distance when air brake and dynamic brake are applied and released, or whether the locomotive engineer is operating in a *false gradient*. That is, after release, air brakes that are not fully recharged before another application is made, are extracted. Additionally, information such that the engineer is *power-braking* (that means that the throttle is in a notch higher than #4 while the air brakes are applied), are recorded. This train handling techniques have effect on train average temperatures. Train handling details of one of the trains of interest is described in the following.

Figure 27 shows pressure in the equalizing reservoir (EQT), speed, dynamic brake (DB), and throttle from mile 74.4, when the train is ascending the Mount Macdonald Tunnel, throughout the Mountain subdivision to mile 125.7 and then through Shuswap subdivision to detector at MP 90.

The average levels of selected indicators are used for the calculation. Average values are calculated from the interval when the air brakes are applied prior to arrival on detection sites. These intervals are from the tunnel exit to MP 95.1, from MP 95.1 to MP 111.7, and the interval of air brake application prior the MP 90. These intervals are highlighted by the blue rectangles in Figure 27.

The following train handling data are used for the Brake horsepower calculation:

- Length of the air brake application prior to passing the detectors,
- Length of the air brake release prior to passing the detectors,
- Average speed during the given interval,
- Average EQT pressure during the given interval, and
- Average use of DB in % during the given interval.

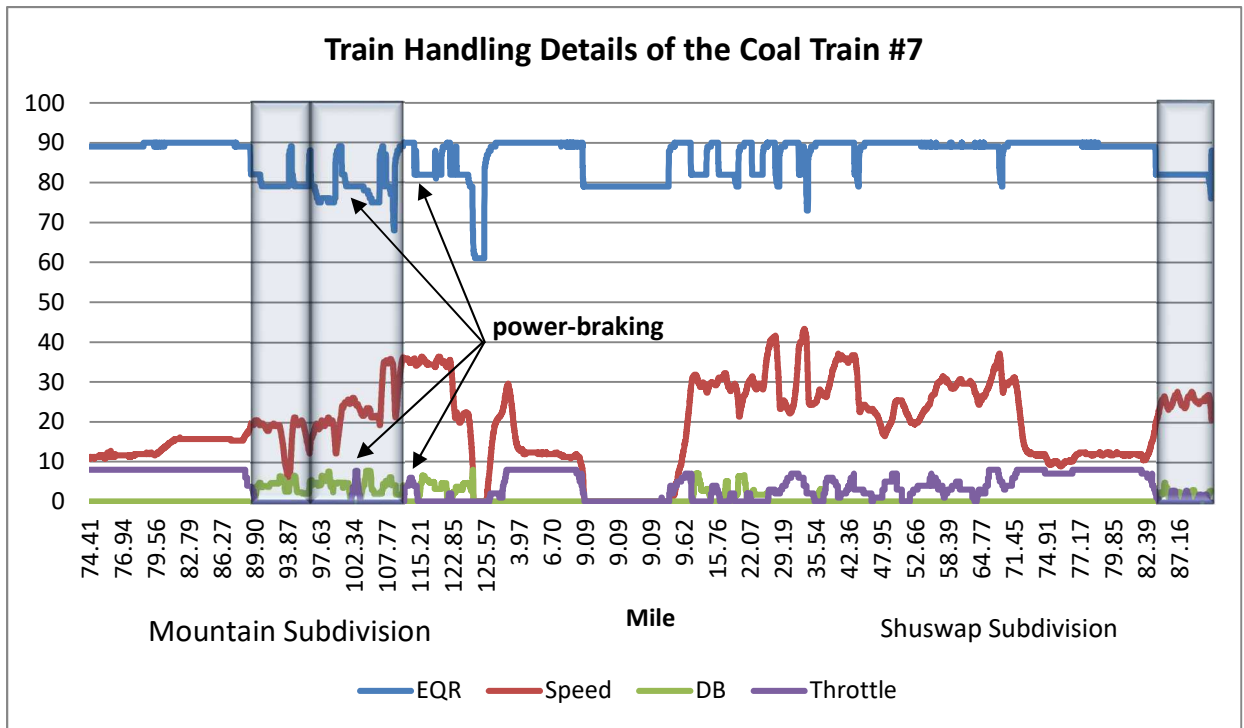

**Figure 27. Train handling data**

**Locomotive Train Handling Details of a Coal Train #7 Passing the CP's Mountain Subdivision**

Train ID: #7

Passing detectors on: March 2, 2017

ATBE: Valid

Train Average Temperature at Mile Post 95.1: 206.3°F (96.8°C)

Train Average Temperature at Mile Post 111.7: 214.3°F (101.3°C)

Cold Wheel Alarms: yes

Track profile is depicted in Figure 28.

### Train Handling Details:

- 7:26 AM (mile 74.41) train is ascending 1% grade towards Mount Macdonald tunnel at speed between 11.2 mph and 11.9 mph
- 7:53 AM (mile 79.6) train enters Mount Macdonald tunnel at speed 11.9 in throttle 8
- 8:00 AM (mile 81.33) speed in the tunnel increased to 15.7 mph because of the lower ascending grade, roughly 0.75%
- 8:28 AM (mile 88.6) train exits the Mount Macdonald tunnel at speed 16.1 mph
- 8:30 AM (mile 89.34 – Ross Peak) train reaches speed of 19.1 mph and the minimal air brake **application** is made (**EQR=82 psi**)
- 8:33 AM (mile 90.02) train is descending the grade at 20.6 mph speed, and dynamic brake is applied
- 8:34 AM (mile 90.7) further 3 psi air brake pressure reduction is made (EQR=79 psi), speed is 19.8 mph and dynamic brake is in N5
- 8:42 AM (mile 93.18) dynamic brake is in N6.6 and, air brake EQR = 79, train slows down at Flat Creek
- 8:44 AM (mile 93.92) train speed is 4.4 mph, air brakes are **released (EQR=89 psi)** and dynamic brake is in N2.8
- 8:47 AM (mile 94.08) speed has increased to 15.3 mph, air brakes are **applied (EQR=82 psi)** and dynamic brake is in N5
- 8:47 AM (mile 94.21) further 3 psi reduction is made (EQR=79 psi), speed is 19.1 mph, dynamic brake is in N5.5
- 8:50 AM (**mile 95.1**) train is passing CW detection site, EQR = 79 psi, dynamic brake is in N2.6
- 8:54 AM (mile 96.25) air brakes are **released (EQR=90 psi)**, speed is 13.1 mph and dynamic brake is in N2.7
- 8:54 AM (mile 96.38) are **applied**, 11 psi reduction is made (**EQR=79psi**), speed is 15.7 mph, dynamic brake is in N5.5



- 8:56 AM (mile 96.8) additional 1 psi reduction is made, (EQR=78 psi)
- 8:57 AM (mile 97.05) further 2 psi reduction is made (EQR=76 psi), speed is 19.4 mph, dynamic brake is in N5
- 9:04 AM (mile 99.54) train is descending 2.4% grade at Illecillewaet with air brakes **released (EQR = 89 psi)** speed is 13.4 mph, dynamic brake is in N4.8
- 9:07 AM (mile 100.25) train is descending 1.8% grade at Downie, air brakes are **applied (EQR=82 psi)**, speed has increased to 23.2 mph, dynamic brake is in N5
- 9:08 AM (mile 100.73) further 2 psi reduction is made (EQR=80 psi), speed is 24.7 mph
- 9:10 AM (mile 101.66) dynamic brake is released
- 9:12 AM (mile 102.5) the locomotive engineer is power braking, throttle is in 6, EQR=80, speed is 25.1 mph
- 9:14 AM (mile 103.36) dynamic brake is applied
- 9:15 AM (mile 103.77) further 2 psi reduction (EQR=78 psi), speed is 21.7 mph, throttle 0, and dynamic brake is in N4.5
- 9:17 AM (mile 104.49) additional 2 psi reduction (EQR=76 psi), dynamic brake is in N8, speed is 23.2 mph
- 9:22 AM (mile 106.14) train is passing Albert Canyon with air brakes **released (EQR=90)**, speed is 19.8 mph, dynamic brake is in N2.3
- 9:23 AM (mile 106.76) air brakes are **applied (EQR=82 psi)**, speed is 33.7 mph, dynamic brake is in N4.7
- 9:23 AM (mile 106.85) further 3 psi reduction (EQR=79 psi)
- 9:24 AM (mile 107.25) air brakes are **released (EQR=89 psi)**, speed is 34.8 mph, dynamic brake is in N5.5
- 9:24 AM (mile 107.45) air brakes are **applied (EQR=79 psi)**
- 9:26 AM (mile 108.33) train is approaching Laretta, doing 35.6 mph, additional 2 psi reduction (EQR=77 psi), dynamic brake is in N6.4

- 9:27 AM (mile 109.07) further 9 psi reduction (EQR=68 psi), speed is 34.4 mph and dynamic brake is in N4.4
- 9:28 AM (mile 109.41) air brakes are released (EQR=49 psi), speed is 25.1 mph and dynamic brake is in N4.4
- 9:31 AM (mile 111.35) dynamic brake is released
- 9:32 AM (**mile 111.7**) train is passing detection site with air brakes and dynamic brake released, speed is 35.9 mph

#### 4. Detector data

Detector data are collected from the CP's historical database. The date and time of passing detectors and the speed of the train are compared against locomotive download records. Additionally, ambient temperature from the detectors is used for the dynamic braking impact on the ATBE assessment. This information is important because the wayside temperature detectors measure wheel temperature above the ambient temperature. Table 17 shows the detector data of the coal train #7.

**Table 17. Wayside temperature detectors data**

Date Time (Pacific Time Zone)	Subdivision Milepost	Direction	Train ID	Axles	Train Length (ft)	Speed In (mph)	Speed Out (mph)	Ambient Temp (°F)
02-03-2017 07:50:31	Mountain 95.1	W	7	632	8781	21	18	20
02-03-2017 08:32:22	Mountain 111.7	W	7	632	8781	36	35	25
02-03-2017 13:51:54	Shuswap 90	W	7	632	8781	20	27	37

\*Converse to SI units using *Units conversion table*

## 5. Brake Force Calculator

The brake force calculator is used by the CP for the calculation of retarding forces needed to control the train on grades and is used for this analysis. Train handling information and track profile assumptions are inputs for the BHP calculation.

The gradient of the track on the Mountain subdivision ranges from 1.4% to 2.4%. However, for the purpose of the brake force calculation, a uniform gradient of 2% is used for the section of the track from mile 85 to 95.1 and a gradient of 2.2% is used for the section from mile 95.1 to 111.7. Figure 28 shows the real and the assumed (in blue) profile of the track. Table 18 summarizes gradient, length and the speed limit of the detection sites.

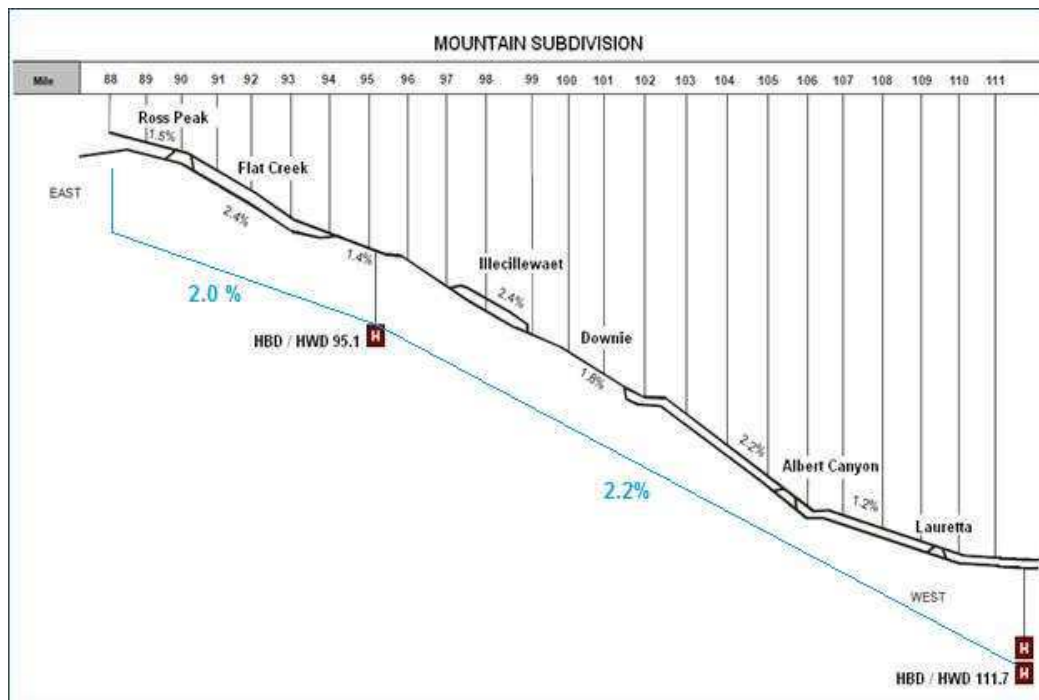

**Figure 28. Track profile of the grade in Mountain subdivision**

Modified from (Canadian Pacific, 2017)

**Table 18. Detection sites specifications**

Subdivision	Mile Post	Grade	Length	Speed Limit
Mountain	95.1	2%	5 miles	20-25* mph
Mountain	111.7	2.2%	10 miles	20-35 mph

\*Freight train may travel at 25 mph speed in given location only if the train meets dynamic brake, number of locomotives, and weight requirements (Canadian Pacific, 2015).

\*\*Converse to SI units using *Units conversion table*

### **Assumptions for calculations**

The following assumptions are used for the brake force calculations needed to control a train descending a steep grade such as on the BC coal loop.

Train assumptions:

- Coal train is made up from 152 identical gondola railcars and 4 identical locomotives
- Each loaded railcar weights 286 000 lbs (129 727.42 kg)
- Each locomotive weight 410 000 lbs (185 972.87 kg)
- Total weight of a train is 22 556 tons

Braking system assumption:

- The train has 100% operative brakes when it departs from the SIL
- Air brake lever ratio is 8
- Brake cylinder diameter is 10 in (0.254 m)
- Each railcar has 1 brake cylinder
- Air brake efficiency is 0.85
- Brake shoe coefficient of friction is 0.3
- Locomotive AC 4400 has dynamic brake effort capability of 98 000 lbs (44 452.1 kg)

Track assumptions:

- Track gradient between milepost 95.1 and 111.7 is 2.2%

Operation assumptions:

- Train is handled in the way, that after the brakes are released they are fully charged, that is, the locomotive engineer is not operating in a false gradient

### Dynamic braking calculation formulas

#### Brake Cylinder Area

$$A_{BC} = \frac{\pi * d^2}{4} \quad \text{Equation 5-1}$$

Where:

$A_{BC}$  - Brake Cylinder Area [in<sup>2</sup>]

$d$  - diameter [in]

#### Train Retarding Force

$$F_T = W_T * m * 20 \quad \text{Equation 5-2}$$

Where:

$F_T$  – Train Retarding Force [lbs]

$W_T$  – Total Train weight [ton]

$m$  – gradient [%]

#### Air Brake Retarding Force

$$F_{AB} = F_T - (DB_C * n_l * db) \quad \text{Equation 5-3}$$

Where:

$F_{AB}$  – Air Brake Retarding Force [lbs]

$F_T$  – Train Retarding Force [lbs]

$DB_C$  – Dynamic Brake Capability per Locomotive [lbs]

$db$  – Percentage of applied dynamic brake based on the DB notch [%]

$n_l$  – number of locomotives in the consist

### Retarding Force per Railcar

$$F_C = \frac{F_{AB}}{n_c} \quad \text{Equation 5-4}$$

Where:

$F_C$  - Retarding Force per Car [lbs]

$F_{AB}$  – Air Brake Retarding Force [lbs]

$n_c$  – Number of cars

### Brake Force per Railcar

$$BF_C = \frac{F_C}{\mu_k} \quad \text{Equation 5-5}$$

Where:

$BF_C$  - Brake Force per Railcar [lbs]

$F_C$  - Retarding Force per Railcar [lbs]

$\mu_k$  - Brake Shoe coefficient of friction

### Brake Cylinder Press

$$P_{BC} = \frac{BF_C}{L * A_{BC} * n_{BC} * E_{AB}} \quad \text{Equation 5-6}$$

Where:

$P_{BC}$  - Brake Cylinder Press [psi]

$L$  – Lever Ratio

$A_{BC}$  - Brake Cylinder Area [in<sup>2</sup>]

$n_{BC}$  – Number of Brake Cylinders

$E_{AB}$  – Air Brake Efficiency

### Brake Pipe Drop

$$BP = \frac{P_{BC}}{2.75} \quad \text{Equation 5-7}$$

Where:

$BP$  - Brake Pipe Drop [psi]

$P_{BC}$  - Brake Cylinder Press [psi]

### Brake Horsepower per Wheel

$$BHP_W = \frac{(F_C/8 * v_T)}{375} \quad \text{Equation 5-8}$$

Where:

$BHP_W$  - Brake Horsepower per Wheel [BHP]

$F_C$  - Retarding Force per Railcar [lbs]

$v_T$  – Train Speed [mph]

## 5.2 Dynamic Braking Calculation Results

Impacts of dynamic brake applications on the required BHP per wheel to control train speed is calculated using the formulas above, in the Excel spreadsheet. Results in Table 19 show that the BHP method is informative only and is not sufficient to determine exact heat generation between the brake shoe and the wheel. A heat transfer model is needed for more precise train temperature estimate. Specifically, heat transfer models for different brake shoe types and materials, and brake system configurations (which account for the air brake application durations) are needed.

**Table 19. Dynamic braking results**

	Mountain 95.1		Mountain 111.7		Shuswap 90	
	Actual	No DB	Actual	No DB	Actual	No DB
Grade (%)	2	2	2.2	2.2	1	1
Speed (mph)	17.5	17.5	24.1	24.1	25.7	25.7
Air Brake-EQR (psi)	80	77	80	75	82	83
Dynamic Brake Notch	5	0	4.5	0	2.9	0
DB available at given speed (lbs)	392 000	392 000	216 000	216 000	392 000	392 000
DB used (%)	57.5	0	56.3	0	26.3	0
DB used (lbs)	225 400	0	121 500	0	102 900	0
Brake Force Needed to Control Grade (lbs)	14 970	19 800	16 930	21 770	7 430	9 900
BC Press Needed to Control Grade (psi)	28	37	32	41	14	19
BP Drop To develop Required BC Pressure (psi)	10	13	12*	15	5*	7
BHP/Wheel (BHP)	<b>26</b>	<b>35</b>	<b>41</b>	<b>52</b>	<b>19</b>	<b>25</b>
Retarding Force Needed (lbs)	902 240	902 240	992 464	992 464	451 120	451 120
Retarding Force Needed from Air Brakes (lbs)	681 740	902 240	771 964	992 464	348 220	451 120
Retarding Force Needed per Railcar (lbs)	4 490	5 940	5 080	6 530	2 230	2 970
Brake Force Needed per Railcar (lbs)	14 970	19 800	16 930	21 770	7 430	9 900
Ambient (°F)	20	20	25	25	37	37
Train Avg Temp (°F) (Above Ambient)	<b>206.32</b>	<b>270.8</b>	<b>214.3</b>	<b>265.1</b>	<b>216</b>	<b>272.5</b>

\*Real life values are impacted by the train handling, operating in the false gradient or power-braking; duration of the air brake application and release, brake shoe materials and brake system configurations.

\*\*Converse to SI units using *Units conversion table*



Figure 29 depicts the difference in BHP needed on different grades with use of dynamic brakes and air brakes, and with air brakes only. Figure 30 a) shows in service use of air brakes supplemented with up to 75% of AC traction motors dynamic brakes capability at given speed. Figure 30 b) shows the additional BHP from air brakes required to maintain given speed, if the dynamic brakes are not used. On lighter 1% grades, an increase of up to 200% of BHP is needed, while on heavier grades (where air brakes are already heavily used) additional 50% BHP is required.

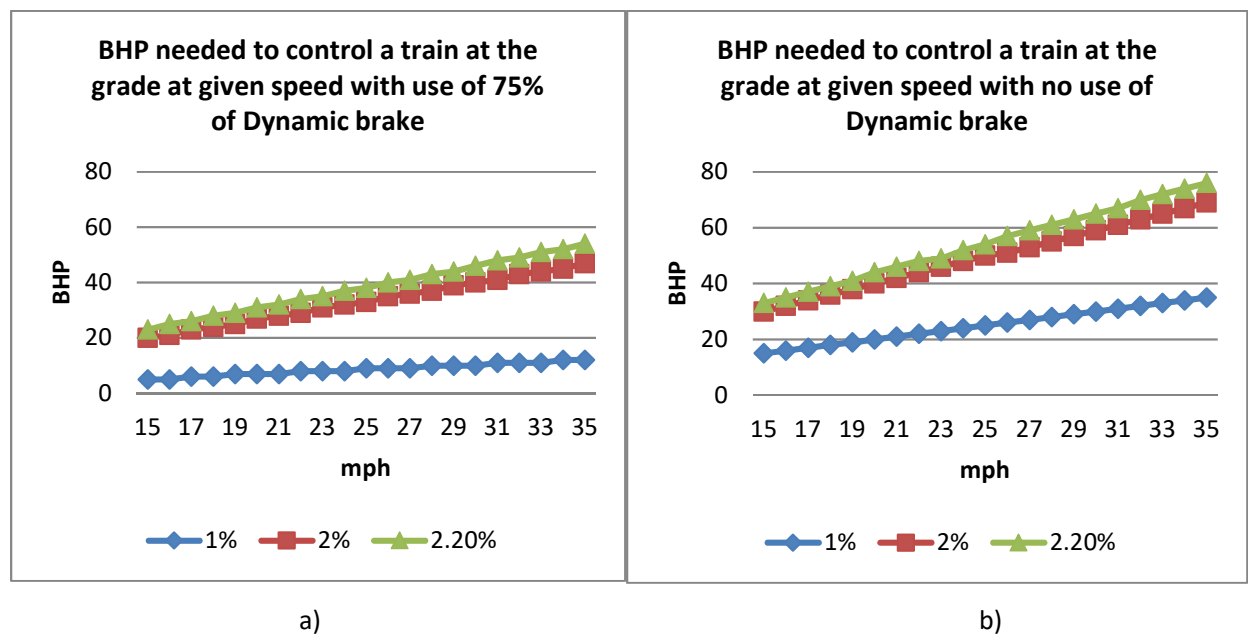

**Figure 29. Brake Horse Power required to control train speed**

The use of dynamic brakes together with air brakes is additional tool of a locomotive engineer to control speed of heavy trains when descending grades. Dynamic brake applications decrease amount of required BHP. Fewer air brake applications decrease the amount of friction between brake shoes and wheels. The current ATBE process is able to detect air brake system defects due to the train wheel temperature distributions analysis followed by the evaluation of currently used alarm rules. In the case that new detection sites (which might require different train handling

techniques) are proposed, an assessment of train wheel temperature measurements and development of new alarm rules might be required or the ATBE's applicability must be evaluated.

## 6 Conclusion and Future work

### 6.1 Conclusion

The main objective of this thesis is to perform a comparative assessment of two air brake inspection methods currently used in Canada. The No. 1 Brake Test, currently regulated by the federal regulatory body Transport Canada, is a manual/visual inspection during which railcar mechanics drive ATVs alongside static trains to visually inspect piston travel, brake rigging, and brake application and release. The main limitations of the No. 1 Brake Test are static conditions, full-service air brake application (which rarely corresponds with actual in-service application) and short duration of brake application (which does not allow for air leakages to manifest themselves). The main advantage of this method is its availability throughout a year, however, harsh conditions affect railcar mechanics visual and hearing senses. This human-based method is compared against the technology-driven train inspection known as Automated Train Brake Effectiveness (ATBE), which is the process currently used by Canadian Pacific on the Coal fleet in Western British Columbia. ATBE employs Wheel Temperature Detectors (WTDs) to identify air brake-related defects on trains under dynamic conditions. This inspection relies on the validation criteria and Cold and Hot Wheel alarm rules, which compare temperatures of individual wheels against the train average temperatures to identify outliers. The main disadvantage of this process is that it depends on the technology reliability, this is, however, mitigated by the process defaulting to the No. 1 Brake Test in a case of the technology failure. Advantages of this process are objectivity of the algorithm and high frequency of monitoring.

Evaluation of the reliability of air brake inspection methods is based on the list of repairs related to the defects resulting in ineffective braking. Analysis shows that on average 52% of railcars alarmed by ATBE have valid repairs and 100% of railcars with completely inoperative air brakes were identified as defective. ATBE is able to identify defects which are not visible during the No.

1 Brake Test. Moreover, the majority of the most frequent failure modes is difficult to see when railcar mechanics pass alongside trains. Additionally, both methods help identify defects not related to the air brake system. While during the No. 1 Brake Test damaged reflective sheeting has been reported, railcars flagged by the ATBE had cracked coupler knuckles, defective wheels, and bearings. Failures of these components, which are not found either during the Safety and Maintenance inspection nor during the No. 1 Brake Test, may pose safety risks. From a rail safety point-of-view the method with higher detection rates is preferred. As investigation shows, there is 1 railcar bad ordered by the No. 1 Brake Test, which is thoroughly inspected for mechanical issues and Single Car Air Brake Tested in a shop, compared to 139 railcars bad ordered by the ATBE process.

This project shows that the technology-driven train inspection is more effective in identifying defects causing insufficient air brake application than a human-based air brake inspection method. Additionally, analysis shows that the reliability of air brake fault detection improves when the defective railcars have multiple cold wheels flagged and these alarms are additionally confirmed by multiple detectors.

#### 6.1.1 Limitations

The main limitation of the research project is unavailability of historical coal railcar No.1 Brake Test records. This disabled to perform direct equivalence testing of air brake inspections methods reliability.

To compare both methods, two case studies were performed on grain fleet. Both tests were, however, limited by the samples sizes. Moreover, neither of the studies were done through parallel testing, which would yield the most accurate results of comparative assessment.

## 6.2 Recommendations to Industry

In the process of working on this research project with CP, it came to light that there are some areas of data management and the ATBE process that could be improved. Below are listed suggestions for improvement:

- Improve the No. 1 Brake Test, Safety & Maintenance, and en route inspection data record-keeping. A use of tablets/iPads would allow to collect more accurate data and easier record-keeping, moreover, the access to the inspection information would be immediate.
- Entering results of individual inspections separately would help with inspection methods, evaluation, and future improvement of air brake inspection processes.
- Extend the record-keeping period of Dynamic Scan Ratio in the database.
- Enter brake shoe replacement location into the maintenance database to allow investigation of how brake shoes impact braking performance and the ATBE process.
- Collect locomotive downloads from summer and winter seasons to enable analysis of train handling impact on the wheel temperature.
- Streamline databases to make complete railcar history and data from multiple sensing devices available in one place.
- Keep maintenance records of railcars whose repairs was outsourced
- Maintain ATBE test conditions consistency of air brake application prior to detection sites, passing speed over detectors, and limit train stops prior to passing detectors.

## 6.3 Future Work

Future work involves the development and evaluation of algorithms for new cold wheel detection sites with different track profiles across the North American railways network to increase rail

safety. The effect of train handling techniques and dynamic braking impacts on wheel temperatures needs to be analyzed prior to the development of new algorithms. Furthermore, an investigation of truck-based and mechanical failures impacts on the ATBE validity rate should be conducted. Finally, possibilities of other train inspection automatization must be explored.

## References

- Ahmad, H. A. (2013, February 20). Dynamic Braking Control for Accurate Train Braking Distance Estimation under Different Operating Conditions. *Dissertation*. Blacksburg, VA, USA: Virginia Polytechnic Institute and State University.
- AREMA. (2013). Practical Guideline to Railway Engineering.
- AREMA. (2013). *Practical Guideline to Railway Engineering*.
- Aronian, A., Jamieson, M., & Wachs, K. (2012). Automated Train Brake Effectiveness (ATBE) Test Process at Canadian Pacific. *Proceedings of the 2012 Joint Rail Conference, JRC2012-74035* (pp. 1-9). Philadelphia: ASME.
- Aronian, A., Mulligan, K., & De Blois, S. (2016, June 16). Automated Train Brake Effectiveness. (D. Juhaszova, Interviewer)
- Aronian, A., Wachs, K., Jamieson, M., Carriere, K., & Gaughan, E. W. (2012). Testing and Validation of Long Trains Under High Flow and Gradient Conditions. *Joint Rail Conference JRC2012* (pp. 1-11). Philadelphia: ASME.
- Association of American Railroads. (2015). Field Manual of the AAR Interchange Rules. Washington, D.C., USA.
- Association of American Railways AAR, TTCI. (2014). *Machine Vision Inspection*.
- Bafaro, F. (2017, October 25). CP processes in Golden yard. (D. Juhaszova, Interviewer)
- Brake, D., & Chiu, W. K. (2005). Structural Health Monitoring in the Railway Industry: A Review. *Structural Health Monitoring*, 81-93.
- Butlewski, M., Jasiulewicz-Kaczmarek, M., Misztal, A., & Slawinska, M. (2015). *Design Methods of Reducing Human Error in Practice*. London: Safety and Reliability: Methodology and Applications - Nowakowski et. al. (Eds); Taylor & Francis Group.
- Canadian Pacific . (2017, October 19). *Our Markets*. Retrieved from Grain: <http://www.cpr.ca/en/our-markets/grain>
- Canadian Pacific & WoodyzWorx. (2017). Golden Yard. Canada.
- Canadian Pacific. (2011). Air Brake Effectiveness - Cold or Hot Wheel - No Exception. Calgary.
- Canadian Pacific. (2011). ATBE Cold or Hot Wheel - Could Not Verify - Perform #1 Air Brake Test. Calgary.
- Canadian Pacific. (2011). Automated Train Brake Effectiveness - ATBE Cold or Hot Wheel - Alarm Exception. Calgary.
- Canadian Pacific. (2011). Corrective Action Process To Repair Car with Cold & Hot Wheel Defect. Calgary.
- Canadian Pacific. (2015). *Canadian Operating Rules & Practices: Timetables: Mountain and Shushwap Subdivision*.

- Canadian Pacific. (2015, October). Locomotive Braking System. *Locomotive Engineer Training*. Canada.
- Canadian Pacific. (2016). General Operating Instructions (GOI), Section 13, Air Brake Tests and Procedures. Canada.
- Canadian Pacific. (2017). ATBE - process performance tracking. Canada.
- Canadian Pacific. (2017). Automated Train Brake Effectiveness - Grain Fleet. Calgary, AB, Canada.
- Canadian Pacific. (2017). *Freight Car Inspection*.
- Canadian Pacific. (2017). *Freight Car Inspection*.
- Canadian Pacific. (2017). Mountain Subdivision Track Profile. *Train Handling Details*. Canada.
- Carriere, K. J., & Gaughan, E. W. (2015). Automated Brake Testing and the Benefits of Four Pressure Test. *IHHA*. Perth, Australia.
- Cummings, S. (2009). Brake Shoe Force Variation. *Proceedings of ASME 2009 Rail Transportation Division Fall Conference, RTDF2009-18021*. Fort Worth, Texas, USA.
- Cummings, S., Tournay, H., & Gonzales, K. (2008, March). Wayside Wheel Temperature Detector Test. *Technology Digest TD-08-013*.
- Duda, R. O., & Hart, P. E. (2011). *Pattern Classification*. New York: John Wiley & Sons, Inc.
- EL-Houmayra, J. (2011). *Quantitative and Qualitative Methodes: Decision Making*. Edmonton: University of Alberta.
- Elia, M., Diana, G., Bocciolone, M., & Resta, F. (2006). Condition Monitoring of the Railway Line and Overhead Equipment through Onboard Train Measurement - an Italian Experience. *The Institution of Engineering and Technology International Conference on Railway COndition Monitoring*, (pp. 102-107). Birmingham.
- Fawcett, T. (2005). An introduction to ROC analysis. *Elsevier - Pattern Recognition Letters*, 861-874.
- Frauscher Sensor Technology. (2016). *Wheel Detection Systems Functions*. Retrieved from Frauscher Sensor Technology Web site: [http://www.frauscher.com/en/overview\\_wheel\\_detection\\_systems/](http://www.frauscher.com/en/overview_wheel_detection_systems/)
- Government of Canada. (2008, December 29). *Transportation Safety Board of Canada*. Retrieved from Railway Investigation Report R08V0270: <http://www.bst-tsb.gc.ca/eng/rappports-reports/rail/2008/r08v0270/r08v0270.asp>
- Harubin, H. (1980). AFM: Development of an Alternate Method of Testing Trains. *Canadian Air Brake Club*.
- Hodge, V. J., O'Keefe, S., Weeks, M., & Moulds, A. (2015). Wireless Sensor Networks for Condition Monitoring in the Railway Industry: A Survey. *IEEE Transactions on Intelligent Transportation Systems*, 16(3), 1088.
- International Society of Automation. (2017, December 10). *International Society of Automation*. Retrieved from Units Conversion Tables: [https://www.isa.org/uploadedFiles/Content/Training\\_and\\_Certifications/ISA\\_Certification/CCST-Conversions-document.pdf](https://www.isa.org/uploadedFiles/Content/Training_and_Certifications/ISA_Certification/CCST-Conversions-document.pdf)



- Jamieson, M., & Aronian, A. (2014). *Update on Technology Driven Train Inspections at Canadian Pacific*. Calgary: RSI/CMA 2014 – ABA Annual Conference.
- Linne, A., & Juntti, U. (2011). Improving Conditions for Personnel Performing Condition-Based Maintenance on Infrastructure by Measuring/Monitoring Their Winter Performance Ability. *International Congress on Condition Monitoring and Diagnostics Engineering Management* (pp. 1449-1456). Stavanger, Norway: CIAM, DNV.
- Liu, Y., Steinginga, L., Davies, T., Mulligan, K. R., Heffernan, T., Lipsett, M., . . . Aronian, A. (2017). Assessment on automated train brake effectiveness (ATBE) - Phase I. *IHHA*. Ottawa.
- Mulligan, K. R. (2017, November 20). Operations in the Railway Industry. (D. Juhaszova, Interviewer)
- National Research Council Canada. (2016). *Preliminary Analysis of CP Wheel Temperature Data and Test Plan*, . Ottawa: NRC.
- New York Air Brake. (2017). How Cold Wheel Detection System Work.
- Nickerson, W. G., Manges, W., & Munro, J. J. (2011). Trustworthy Wireless Sensors. *MFPT: The Applied Systems Health Management Conference*. Virginia Beach.
- O'Keefe, P. J. (2010, June 6). *Engineering Expert Witness Blog*. Retrieved from Diesel Locomotive Brakes: <http://www.engineeringexpert.net/Engineering-Expert-Witness-Blog/tag/pneumatic-brake>
- Poddar, V. (2014). *Reliability Centered Maintenance (RCM) and Ultrasonic Leakage Detection (ULD) as a maintenance and condition monitoring technique for freight rail airbrakes in cold weather conditions*. Edmonton: University of Alberta.
- Rabatel, J., Bringay, S., & Poncelet, P. (2011, Jun). Anomaly detection in monitoring sensor data for preventive maintenance. *Exp. Syst. Appl.*, vol.38, no.6, pp.7003-7015.
- Railway-technical. (2016, March 22). *Railway-technical*. Retrieved from Air Brakes: <http://www.railway-technical.com/air-brakes.html>
- Robeda, J. (2011). Technology Driven Train Inspection (TDTI). *16th Annual AAR Research Review*. Pueblo: Transportation Technology Center Inc.
- Robeda, J., Sammon, D., & Madrill, B. (2013). *Using Wheel Temperature Detector Technology to Monitor Railcar Brake System Effectiveness*. Pueblo: Transportation Technology Center.
- Shadkar, A. M. (2016). *Reliability Study and Maintenance Decision Making of Wheel Temperature Detectors*. University of Alberta.
- Shadkar, A., Lipsett, M. G., & Hendry, M. T. (2015). Wayside Wheel Temperature Detector Data Mining to Predict Potential Sensor and Railcar Component Failures. *MFPT and ISA's 61st International Instrumentation Symposium*. Huntsville.
- Transport Canada. (2014). *Railway Freight and Passenger Train Brake Inspection and Safety Rules, TC O 0-184*.
- Wabtec Corporation. (2004). *Freight Car Brake Rigging Arrangements*.
- WabTec Corporation. (2017). Q-Tron Universal Analysis/Download Software (QUADS). Canada.

Ying, C., Lipsett, M. G., Hendry, M. T., & Poddar, V. (2016). *Ultrasonic Leakage Detection for Air Brakes*.  
Edmonton: Canadian Rail Research Laboratory.

Zbylut, C. (2016, June 14). Cold Wheels Machine Vision. *Cold Wheels*. Union Pacific.