

CANADIAN THESES ON MICROFICHE

I.S.B.N.

THESES CANADIENNES SUR MICROFICHE



National Library of Canada
Collections Development Branch

Canadian Theses on
Microfiche Service

Ottawa, Canada
K1A 0N4

Bibliothèque nationale du Canada
Direction du développement des collections

Service des thèses canadiennes
sur microfiche

NOTICE

The quality of this microfiche is heavily dependent upon the quality of the original thesis submitted for microfilming. Every effort has been made to ensure the highest quality of reproduction possible.

If pages are missing, contact the university which granted the degree.

Some pages may have indistinct print especially if the original pages were typed with a poor typewriter ribbon or if the university sent us a poor photocopy.

Previously copyrighted materials (journal articles, published tests, etc.) are not filmed.

Reproduction in full or in part of this film is governed by the Canadian Copyright Act, R.S.C. 1970, c. C-30. Please read the authorization forms which accompany this thesis.

THIS DISSERTATION
HAS BEEN MICROFILMED
EXACTLY AS RECEIVED

AVIS

La qualité de cette microfiche dépend grandement de la qualité de la thèse soumise au microfilmage. Nous avons tout fait pour assurer une qualité supérieure de reproduction.

S'il manque des pages, veuillez communiquer avec l'université qui a conféré le grade.

La qualité d'impression de certaines pages peut laisser à désirer, surtout si les pages originales ont été dactylographiées à l'aide d'un ruban usé ou si l'université nous a fait parvenir une photocopie de mauvaise qualité.

Les documents qui font déjà l'objet d'un droit d'auteur (articles de revue, examens publiés, etc.) ne sont pas microfilmés.

La reproduction, même partielle, de ce microfilm est soumise à la Loi canadienne sur le droit d'auteur, SRC 1970, c. C-30. Veuillez prendre connaissance des formules d'autorisation qui accompagnent cette thèse.

LA THÈSE A ÉTÉ
MICROFILMÉE TELLE QUE
NOUS L'AVONS REÇUE

0-315-08957-1



National Library of Canada

Bibliothèque nationale du Canada

69 Canadian Theses Division / Division des thèses canadiennes

Ottawa, Canada K1A 0N4

56874

PERMISSION TO MICROFILM — AUTORISATION DE MICROFILMER

Please print or type — Écrire en lettres moulées ou dactylographier

Full Name of Author — Nom complet de l'auteur

David Bryan Huebert

Date of Birth — Date de naissance

July 10, 1957

Country of Birth — Lieu de naissance

Canada

Permanent Address — Résidence fixe

251 Bronx Ave
Winnipeg, Manitoba
R2K 0Y8

Title of Thesis — Titre de la thèse

Biphasic Mineral Nutrition of Potamogeton pectinatus

University — Université

U. of Alberta

Degree for which thesis was presented — Grade pour lequel cette thèse fut présentée

M. Sc.

Year this degree conferred — Année d'obtention de ce grade

1982

Name of Supervisor — Nom du directeur de thèse

Paul R. Gorham

Permission is hereby granted to the NATIONAL LIBRARY OF CANADA to microfilm this thesis and to lend or sell copies of the film.

The author reserves other publication rights, and neither the thesis nor extensive extracts from it may be printed or otherwise reproduced without the author's written permission.

L'autorisation est, par la présente, accordée à la BIBLIOTHÈQUE NATIONALE DU CANADA de microfilmer cette thèse et de prêter ou de vendre des exemplaires du film.

L'auteur se réserve les autres droits de publication; ni la thèse ni de longs extraits de celle-ci ne doivent être imprimés ou autrement reproduits sans l'autorisation écrite de l'auteur.

Date

Apr 21, 82

Signature

D. Huebert

UNIVERSITY OF ALBERTA

BIPHASIC MINERAL NUTRITION OF THE
SUBMERGED AQUATIC MACROPHYTE

Potamogeton pectinatus L.

by

DAVID B. HUEBERT

A THESIS

SUBMITTED TO THE FACULTY OF GRADUATE STUDIES AND RESEARCH
IN PARTIAL FULFILMENT OF THE REQUIREMENTS FOR THE DEGREE

OF MASTER OF SCIENCE

IN

PLANT PHYSIOLOGY

DEPARTMENT OF BOTANY

EDMONTON, ALBERTA

SPRING, 1982

THE UNIVERSITY OF ALBERTA

RELEASE FORM

NAME OF AUTHOR David B. Huebert
TITLE OF THESIS Biphasic Mineral Nutrition of the
..... Submerged Aquatic Macrophyte
..... Potamogeton pectinatus L.
DEGREE FOR WHICH THESIS WAS PRESENTED M.Sc.
YEAR THIS DEGREE GRANTED 1982

Permission is hereby granted to THE UNIVERSITY OF ALBERTA LIBRARY to reproduce single copies of this thesis and to lend or sell such copies for private, scholarly or scientific research purposes only.

The author reserves other publication rights, and neither the thesis nor extensive extracts from it may be printed or otherwise reproduced without the author's written permission.

(Signed) ... *D. Huebert* ...

PERMANENT ADDRESS:

..... 251 Bronx Avenue
..... Winnipeg, Manitoba
..... R2K 0Y8

DATED . April 8, 1982

THE UNIVERSITY OF ALBERTA
FACULTY OF GRADUATE STUDIES AND RESEARCH

The undersigned certify that they have read, and
recommend to the Faculty of Graduate Studies and Research,
for acceptance, a thesis entitled Biphasic Mineral
Nutrition of the Submerged Aquatic Macrophyte
Potamogeton pectinatus L.
submitted by David B. Huebert
in partial fulfilment of the requirements for the degree of
Master of Science in Plant Physiology.

Paul R. Garbom

Supervisor

W. J. Jeffrey

Michael H. Himmelman

DATE Apr 8/82

ABSTRACT

The biphasic mineral nutrition of Potamogeton pectinatus was examined in relation to the ability of the roots to mobilize S, CO₂, Ca, Mg and several micronutrients from the sediment to the shoots in the absence of one or more of these nutrients in the water phase. Stock cultures of vegetative cuttings of P. pectinatus were grown in a modified Pringsheim's system in constant light. Two or ten cuttings of these stocks, selected for uniformity, were used per experiment. The cuttings were transplanted to containers of pasteurized lake sediment. A thin layer of acid-washed sand was placed on top of the sediment to inhibit diffusion of nutrients into the water phase. The transplants were grown for five weeks at 26°C with a 16-h day at 350 μEm⁻²sec⁻¹ in white, 20-l pails or 750-l fibreglass tanks. The primary data collected consisted of biomass production and shoot nutrient concentration values in relation to the presence or absence of various nutrients in the water phase. Subsidiary data on shoot morphology, flower production, and survival rate of plants were also recorded.

The results indicated that the roots of P. pectinatus were capable of mobilizing sufficient amounts of some but not all of the essential elements for normal growth from the sediment to the shoots. Sufficient amounts of P, S, N and micro-nutrients were mobilized by the roots from the sediment. Potassium was mobilized in sufficient amounts from three different sediments to fulfill growth requirements but not to satisfy a more generalized secondary requirement, possibly related

to anion neutralization. In the absence of K from the water phase Na appeared to be an adequate, equimolar replacement for this secondary requirement.

The roots of P. pectinatus were not capable of mobilizing sufficient CO_2 , Ca, or Mg from the sediment to the shoots for normal growth requirements. These elements must be supplied in whole or in part from the water phase. It was found that 2 ppm Ca, 10 ppm Mg, and 0.5 meq HCO_3 in the water phase was sufficient for normal growth under the experimental conditions used. In addition, it was found that a critical concentration of Ca was necessary in the water phase to protect the shoots from the toxicity of other divalent cations when present in the water phase in significant concentrations.

ACKNOWLEDGEMENTS

The successful completion of this thesis was made possible through the assistance of several people and the University of Alberta.

First and foremost I would like to thank Dr. Paul Gorham for his excellent ideas and guidance. Marianne Klenka deserves mention for her assistance in carrying out a myriad of water and plant chemical analyses. I would also like to thank Elizabeth Worobec for her unfailing support. A Graduate Teaching Assistantship given by the Department of Botany, University of Alberta, provided financial support for this thesis.

TABLE OF CONTENTS

	Page
INTRODUCTION	1
METHODS	7
RESULTS	18
DISCUSSION	45
LITERATURE CITED	54
• APPENDIX	58

LIST OF TABLES

Table	Description	Page
1.	Characterization of Lake Wabamun, Cooking Lake, and J- Canal Sediment.	13
2.	Water-phase chemical analyses in relation to experimental nutrient status.	19
3.	Biomass production (mg. dry wt. \pm S.E.) of <i>P. pectinatus</i> in a standard -P nutrient solution in relation to conditions of sediment pasteurization.	21
4.	Biomass (mg. dry wt. \pm S.E.) after five weeks growth in relation to water-phase nutrient status and season in which plants were grown.	22
5.	Biomass (mg. dry wt. \pm S.E.) production on three sediments for two water-phase nutrient conditions.	38
6.	Final biomass (mg. dry wt. \pm S.E.) after five weeks growth using tubers as inoculum material.	40
7.	Minimum water-phase nutrient requirements. Biomass (mg. dry wt. \pm S.E.) after five weeks growth in relation to water phase-nutrient status.	42
8.	The apoplasmic calcium requirement. Biomass (mg. dry wt. \pm S.E.) after five weeks growth in relation to water-phase nutrient status.	44

LIST OF FIGURES

Figure	Description	Page
1.	Dry weight vs. number of leaves for cultures of <u>P. pectinatus</u> grown at constant light and temperature conditions in 125 ml Erlenmeyer flasks.	16
2.	Flower production and percent survival of <u>P. pectinatus</u> in relation to water-phase nutrient status.	26
3.	Nutrient concentrations of <u>P. pectinatus</u> shoots grown under defined conditions for five weeks in the presence (+) and absence (-) of specified water-phase nutrients, compared to averages reported (1) by Hutchinson (1975) and critical concentrations reported (2) by Gerloff and Kromholz (1966).	29
4.	Nutrient concentrations of <u>P. pectinatus</u> shoots in the presence (+) and absence (-) of specified water-phase nutrients as compared to averages (1) reported by Hutchinson (1975). The % organic figure is an average for all treatments. The Na data is expressed in terms of the presence (+) or absence (-) of water-phase K.	31
5.	Concentrations of Na and K (mmoles g^{-1}) in shoots of <u>P. pectinatus</u> in the presence (+K) and absence (-K) of water-phase K.	35
6.	A summary of the ability of <u>P. pectinatus</u> to mobilize nutrients from the <u>sediment</u> and the water phases.	53

LIST OF PHOTOGRAPHIC PLATES

Plate	Description	Page
1.	Vegetative cuttings of a clone of <u>P. pectinatus</u> grown in Pringsheim's solution.	8
2.	Stock cultures of vegetative cuttings of a clone of <u>P. pectinatus</u> on illuminated shelves in a 21°C culture room.	9
3.	750 - 1 fibreglass tanks equipped with temperature-regulating stirrers.	11
4.	20-l plastic pail with a pair of two-week-old plants.	12
5.	Plants of <u>P. pectinatus</u> in Styroware plastic cups containing Lake Wabamun sediment with a sand layer on top showing the transplant (right) and harvest (left) stages.	23
6.	Typical young, established <u>P. pectinatus</u> transplant showing root development in sediment and stoloniferous growth habit.	24
7.	Fully mature <u>P. pectinatus</u> plants in fruiting stage after 7 weeks growth in a -P-K nutrient solution.	39

INTRODUCTION

Submerged aquatic vascular plants such as Potamogeton pectinatus L. are ecologically adapted to grow with their roots buried in the anaerobic sediment phase and their shoots submerged in the aerobic water phase. Mineral nutrients for the growth of these plants are potentially available from both the sediment and water phases. The relative contributions of these two distinct phases to the mineral nutrition of submerged aquatic plants is a topic which has been long examined by researchers (for early work see Arber, 1920).

Historically, research has focused on root function. The earliest stated hypothesis was that roots function only as holdfasts, having no role in mineral nutrient uptake (Arber, 1920; Shannon, 1953). The shoots were assumed to be the only site of mineral nutrient absorption. This viewpoint was supported by the structural observations of reduced roots, reduced vascular systems, and thin leaves lacking cuticles in submerged aquatic plants. Shannon (1953) challenged this view by demonstrating the existence of root hairs in a wide range of aquatic macrophytes. However, the assumption of such strict structure-function relations is unwarranted without supporting experimental evidence.

These early statements concerning the function of roots and shoots were first examined experimentally by Pond in 1905. He grew comparative biphasic cultures of several submerged aquatic plants rooted in soil, rooted in sand, anchored over soil, and anchored over sand, all in lakewater. The results clearly indicated for the species tested that the lack of a nutrient-rich rooting medium significantly

decreased growth. Snell (1908) got the same results using similar methods. He stated that roots absorb and translocate mineral nutrients and that leaves can absorb nutrients under certain conditions. However, Brown (1913) obtained results in direct opposition to Pond and Snell, concluding that roots function chiefly by anchoring plants near the sedimentary CO_2 source. These latter results may be explained by the fact that Brown used soft water with a low alkalinity (Hutchinson, 1975) so that the plants used were CO_2 -starved and the results were artifacts of his conditions. Bourn (1932) clarified these opposing views by strictly controlling the water phase CO_2 and O_2 concentrations in his cultures. His results agreed with those of Pond and Snell and can be summarized as follows: loss of a nutrient-rich substrate markedly decreased growth; the water phase composition can also affect growth; the response to different phase distributions of nutrients is species-specific.

The early work of Pond, Snell and Bourn has been confirmed recently by Mulligan and Baranowski (1969), Mulligan, Baranowski and Johnson (1969, 1976), and Denny (1972) using essentially the same culture methods. In addition, Denny (1972) has shown that the species-specific response is related to structural features such as vascular differentiation and degree of submergence. He has also suggested that the major site of absorption is facultative and may change according to relative nutrient concentrations in the sediment and water phase.

Examining biphasic nutrition from another direction, Moyle (1945), Spence (1967), Seddon (1972), and Pip (1979) have shown that correlations exist between water-phase chemical parameters and plant distributions. These correlations imply that some factor in the water

phase affects the competitive ability of submerged macrophytes which further suggests the importance of the shoots in some aspect of the plants' mineral nutrition. Moyle (1945) has divided the aquatic flora of Minnesota into softwater, hardwater, and high-sulfate-water species. He states that each species has its own particular set of water-phase conditions for optimum growth. Spence (1967) has examined the Lochs of Scotland and found two distinct associations correlated with alkalinity and pH. He states that water chemistry is the primary determinant of plant distribution. Seddon (1972) has examined growth correlations with the degree of water hardness and with conductivity. Pip (1979) has found correlations between growth and a number of parameters, the most important being alkalinity. However, no workers have found consistent correlations with concentrations of nutrients such as nitrogen, phosphorus, or potassium, in the water phase.

The studies cited have shown that both the roots in the sediment and the shoots in the water phase are important in supplying mineral nutrients to submerged macrophytes and have adequately dispelled the notion of roots serving only as anchors. They have also indicated that the relative contributions by the two phases are species-, and perhaps situation-, specific. The studies cited have not, however, defined precisely the relative roles of roots and shoots in nutrient uptake. To understand the nature of biphasic nutrition in greater detail specific experiments are required involving the examination of each nutrient individually and its ability to be absorbed and translocated by the roots and/or shoots.

Uptake kinetics for roots and/or shoots of submerged macrophytes have been studied for sulfate (Jeshke and Simonis, 1965), phosphate

(Jeshke and Simonis, 1965; Mickle, 1975; and Smith, 1978), and potassium (Jeshke, 1970; Mickle, 1975), Jeshke, (1970) and Jeshke and Simonis, (1965) using excised Elodea sp. leaves, have found sulfate, phosphate, and potassium uptake to be dependent on light, temperature, and concentration. Mickle (1975) has shown that the uptake of phosphate and potassium by excised roots and shoots of several aquatic species occurs and is concentration-dependent. Mickle concludes that the relative contribution of the roots in the sediment and the shoots in the water depends on the root/shoot ratios and the distribution of nutrients in the two phases. Smith (1978) has found that phosphate absorption by roots and shoots of Myriophyllum spicatum is light-, temperature-, and concentration-dependent. He concludes that for most of the year phosphorus uptake by the roots is more significant than shoot uptake. These kinetic studies indicate that active shoot assimilation can occur for potassium, sulfate, and phosphate and that active root assimilation can occur for potassium and phosphate.

Studies using various other methods have also been carried out. Bristow and Whitcombe (1971), using a method adapted from Frank and Hodgson (1964), separated the roots and shoots of M. spicatum into two compartments. The application of radiophosphorus into either compartment allowed detection of not only short-term absorption, as in the kinetic studies, but also short-term translocation in either direction. They concluded that the roots are the dominant site of phosphorus uptake with acropetal transport from the roots being far more significant than basipetal transport from the leaves. Since then, using other species, Schults and Malueg (1971) and Twilley, Brinson, and Davis (1977) have supported this view. McRoy and Barsdate (1971), on the other hand, have

reported that phosphorus is taken up either by the roots or shoots and transported throughout the plant. These latter findings have been supported by the work of Demarte and Hartman (1974), Gentner (1976), and Welsh and Denny (1979). Other nutrients have not been studied as extensively. A limited number of uptake studies using calcium (Demarte and Hartman, 1974), iron (Demarte and Hartman, 1974; Gentner, 1976) and nitrogen (Toetz, 1973, 1974; Cole and Toetz, 1975; Nichols and Keeney, 1976) have been carried out which indicate that both root- and shoot-uptake occurs with variable amounts of translocation. Wium-Anderson (1971) has examined CO_2 uptake for Lobelia dortmanna using this compartmentation method. The results indicate that L. dortmanna, which exists in softwater of low alkalinity, obtains all of its needed CO_2 from the sediment via its large roots and extensive lacunar system. This would seem to be a special case and, indeed, Martin, Bradford and Kennedy (1970) have shown with a series of experiments that Najas flexilis, which occurs in water of higher alkalinity, must obtain its required CO_2 from the water phase.

Finally, in an elegant sophistication of this compartmentation method, several researchers have recently cultured plants for extended periods of five weeks or more. This method allows the determination of the relative contribution of the roots under variable water-phase nutrient concentrations or the absolute ability of the roots to mobilize specific nutrients. In this way Bole and Allan (1978), Carignan and Kalff (1980), and Barko and Smart (1979, 1980, 1981) have been able to demonstrate that phosphorus is obtained exclusively from the sediment via the root system. In particular, Carignan and Kalff (1980) grew nine species of submerged aquatic plants in lakes of increasing trophic

status and showed that even at the highest water phosphate concentration the macrophytes obtained greater than 70% of their phosphorus from the sediment. Barko and Smart (1981), Barko (1982) have extended this method to the study of nitrogen and potassium and have concluded that nitrogen, like phosphorus, can be obtained entirely from the sediment but that potassium must be obtained, at least in part, from the water phase.

As a general conclusion it is evident, although until recently still contested (Sculthorpe, 1967), that both the roots in the sediment phase and the shoots in the water phase are important to the mineral nutrition of submerged aquatic macrophytes. Both root and shoot absorption and translocation have been shown to occur for most nutrients studied. Further, it appears that submerged aquatic macrophytes are opportunistic and dynamic in assimilation of mineral nutrients and that different species exhibit differences in assimilative abilities. However, except for phosphorus and, to a limited extent, potassium and nitrogen, the relative contribution by the two phases of other essential nutrients to the mineral nutrition of submerged aquatic macrophytes is unknown. Whether roots are capable of supplying all or only part of the specific mineral nutrient requirements to the shoots and vice-versa has not yet been fully elucidated.

It is the purpose of this research to examine this aspect of the biphasic mineral nutrition of aquatic macrophytes by maintaining a barrier between the roots and shoots of Potamogeton pectinatus L. and determining, under standardized conditions, which nutrients must be supplied via the shoots from the water phase and which can be supplied via the roots from the sediment phase in order to achieve normal growth.

METHODS

The plant used in this study was a clone of the aquatic, Potamogeton pectinatus L., a submerged monophyllous monocot of the family Potamogetonaceae. Experiments consisted of a standardized biphasic-culture method in which vegetative cuttings of P. pectinatus were rooted in a standard sediment (one of three tested) while the water-phase nutrients were altered. Growth responses were measured after a standard time interval.

To guarantee an adequate year-round supply of P. pectinatus for experimental use stock cultures of vegetative cuttings were established from a single winter bud which was freed of algae and most bacteria by the hypochlorite method (Wetzel and McGregor, 1968). The vegetative cuttings were grown at a constant $21 \pm 1^{\circ}\text{C}$ as monophasic, uniplant cultures under continuous cool white fluorescent light of approximately $200\mu\text{E m}^{-2} \text{sec}^{-1}$ (Plates 1 and 2). The culture medium was that of Pringsheim and Pringsheim (1962) modified by the addition of 0.1g. l^{-1} Tris (hydroxymethyl) aminomethane, pH 8.0 (Appendix 1). The culture vessels were 125 ml erlenmeyer flasks containing 75 ml of autoclaved medium. Plants were subcultured every 10-12 weeks by subdivision of stolons between rooted nodes. This was done aseptically in a shallow, sterilized dish in a laminar flow hood using an alcohol-sterilized scalpel.

Biphasic culture experiments were carried out in a controlled environment room set at a constant $26 \pm 1^{\circ}\text{C}$ with photosynthetically active radiation (PAR) supplied at an intensity of $350\mu\text{E m}^{-2} \text{sec}^{-1}$ as measured at the top of the growth containers by a Licor model Li-185A

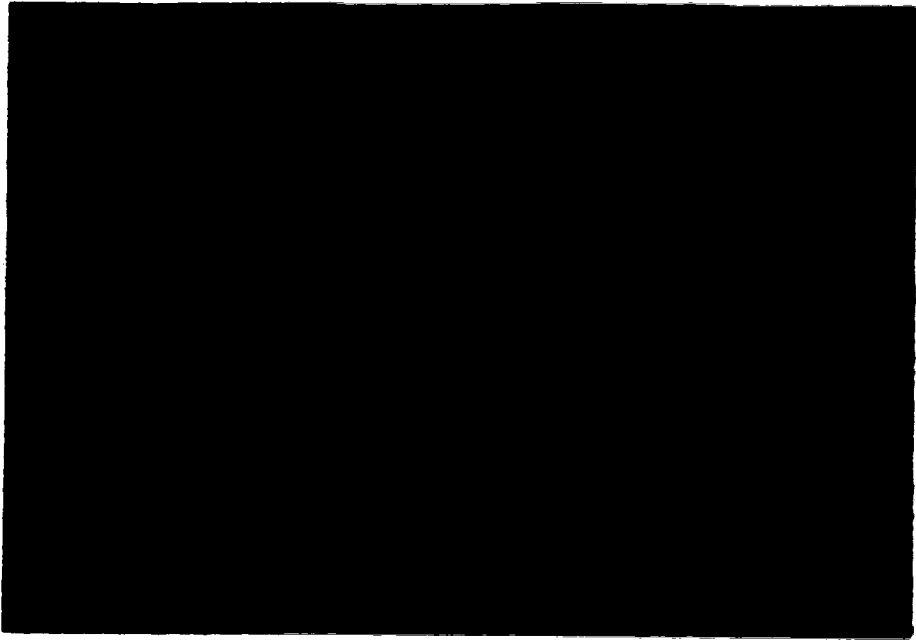

Plate 1. Vegetative cuttings of a clone of P. pectinatus grown in Pringsheim's solution.

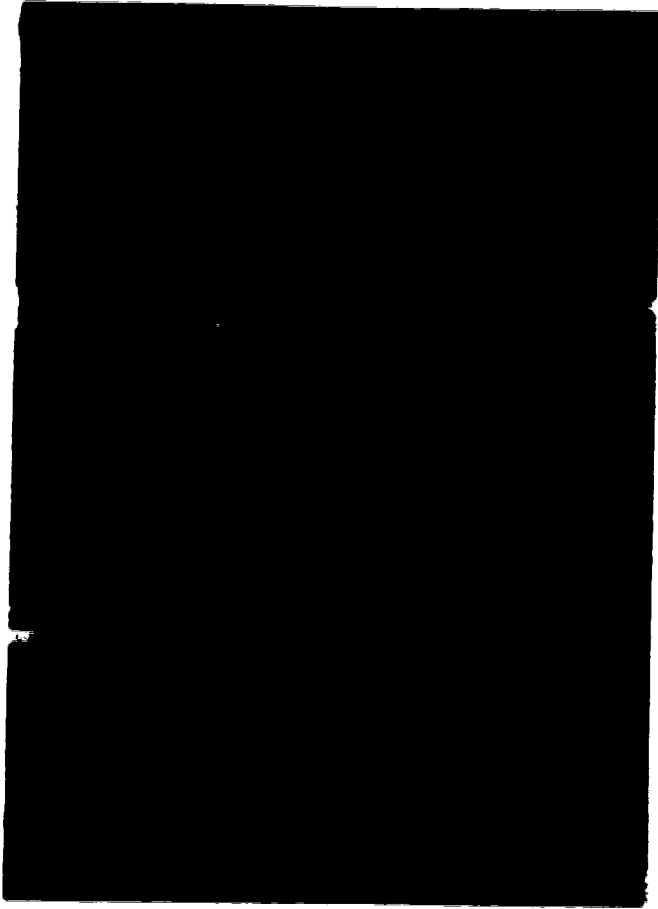

Plate 2. Stock cultures of vegetative cuttings of a clone of P. pectinatus on illuminated shelves in a 21°C culture room.

quantum meter (Lambda Instrument Corp.) equipped with an underwater sensor. Illumination was provided in a 16-h photoperiod by an overhead bank of eighty, 96-in. cool white VHO fluorescent, and forth-eight 150-W incandescent lamps.

Plants were grown in two types of containers. The principal containers were four 750-l tanks 69 cm x 114 cm x 113 cm high, made of white epoxy-coated fibreglass (Plate 3) and the second type were 20-l pails, 43 cm high, made of opaque, white plastic (Plate 4). Solutions in both types of containers were mixed by aeration using Pyrex fritted glass aerators or, in some cases in the tanks, by temperature-regulating stirrers (Frigid Units Inc., Toledo, Ohio) (Plate 3). The stirrers were replaced by fritted glass aerators when the former began to corrode, causing a significant decrease in plant biomass production.

Sediments from three sources were tested to insure that the results were not entirely due to the standard sediment used. These were obtained from an irrigation canal near Vauxhall, Alberta and from profundal locations in Lake Wabamun and Cooking Lake, Alberta. The standard sediment adopted for comparative nutrition experiments was from the location in Lake Wabamun (in Kapasiwin Bay, midway between Point Alison and Indian Point). The sediments were characterized by analysis for K, Na, Ca, Mg, N, P and particle size using standard procedures (Table 1). The analyses were done by the Alberta Agriculture Soil and Feed Testing Laboratory in Edmonton. Sediments were heated to 60°C to suppress contaminating algae in a Thelco Model 28 Precision Scientific oven. When cooled, approx. 200 ml of pasteurized sediment was placed into 285-ml Styroware plastic cups and allowed to settle at room conditions for 3-7 days before being planted. Ten planted sediment containers were used per tank and two were used per pail experiment. The resultant water: sediment

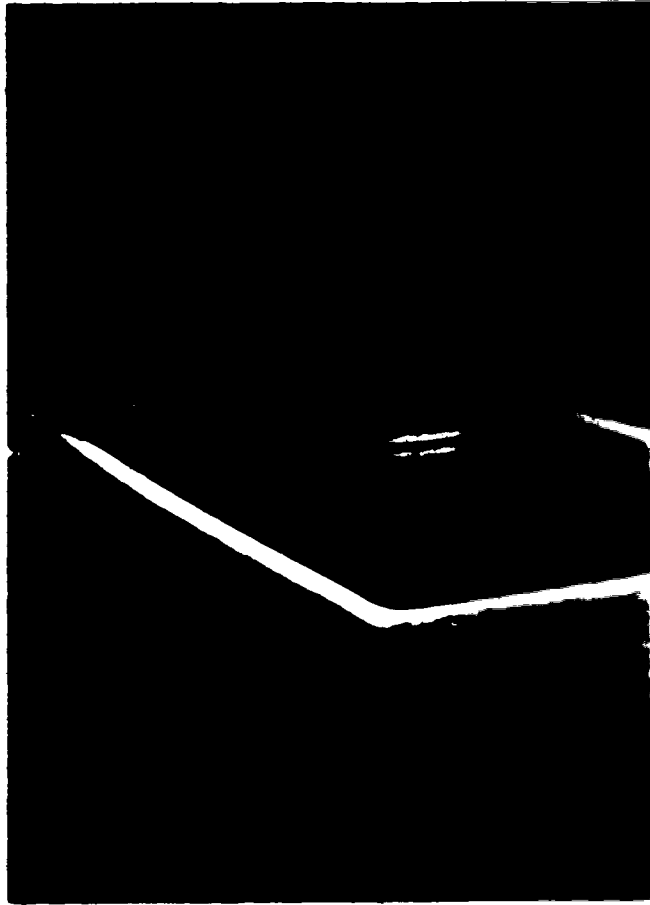

Plate 3. 750 - 1 fibreglass tanks equipped with temperature-regulating stirrers.

T2

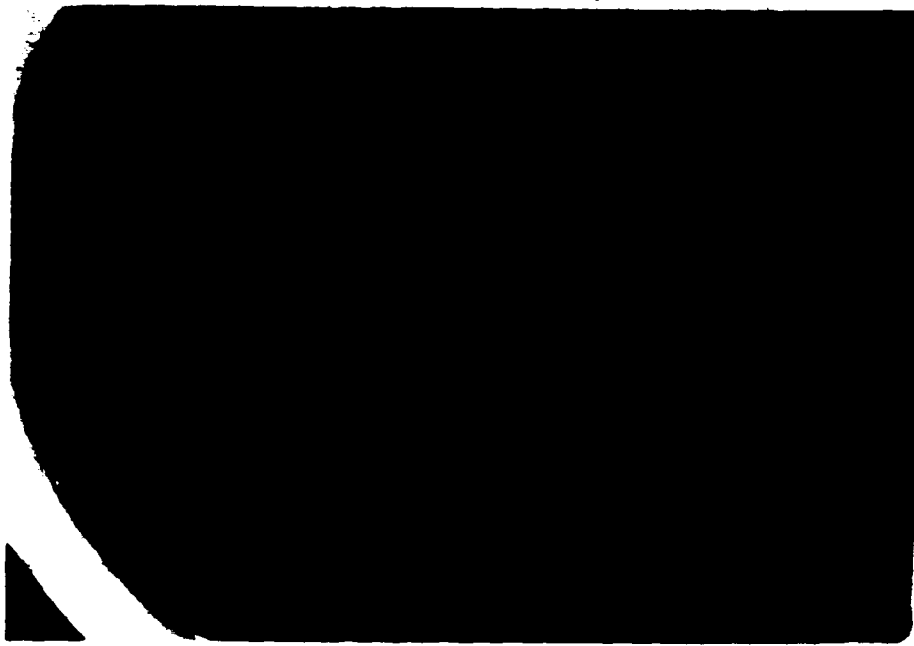

Plate 4. 20 - 1 plastic pail with a pair of two-week-old plants.

TABLE 1

Characterization of Lake Wabamun, Cooking Lake, and ¹J- Canal Sediment. Texture and organic matter are expressed as % dry wt., nutrients as ppm dried sediment.

Parameter	Sediment		
	L. Wabamun (W)	J- Canal (J.C.)	Cooking L. (Co)
Sand	53.2	63.2	
Silt	34.8	24.8	
Clay	12.0	12.0	
Organic	23.0	1.9	38.7
Na	640.2	97.3	4151.0
K	453.4	149.5	1080.0
Ca	4773.0	2937.0	2271.0
Mg	1080.0	444.7	2766.0
NH ₄ -N	11.6	6.2	9.9
PO ₄ -P	1.5	0.5	3.0

¹Site near Vauxhall, Alberta

v/v ratios were 375:1 and 50:1, respectively.

The standard experimental water-phase medium and conditions were as follows: 16ppm K^+ ; 1.5ppm NO_3^- - N; 0.0ppm P; 20ppm Ca^{2+} ; 10ppm Mg^{2+} ; 13 ppm SO_4^{2-} - S; 25ppm Na^+ ; conductivity 350 μ hos. cm^{-1} ; and a micronutrient concentration (containing Fe, Zn, Mn, Co, Cu, B, and Mo) at one-tenth that of the Wetzel II medium (Wetzel and Manny, 1972). The temperature was $24 \pm 1^\circ C$, the alkalinity $0.5 \text{ meq. l}^{-1} HCO_3^-$, and the pH 8.0 ± 0.3 . The water used throughout was distilled and further purified by passage through a Barnstead organic filter followed by a Barnstead cation filter. Before using the purified water 20-1 was first passed through the two filters and discarded. Careful records of consumption were kept and expended filters were replaced according to the manufacturer's instructions.

Experiments were initiated by transplanting to the settled sediment in each of the plastic cups one aseptically grown P. pectinatus plantlet having 2-8 leaves and a healthy root system. A standard curve relating leaf number to plantlet dry weight was used to determine initial mg. dry weight of each plantlet (Fig. 1) which varied from 3.8 - 5.4 mg throughout. The inoculated sediment was then covered with a 2.5-cm layer of 20-30 mesh acid-washed Ottawa sand. Sand layers like this have been shown by Hynes and Grieb (1970) to greatly decrease diffusion of ions from the sediment into the water phase. Finally, the planted containers were rinsed with distilled water, placed into the tanks or pails filled with various water-phase nutrient formulations, and allowed to grow for 35 days. Transplants that did not survive were not included in the biomass analyses.

Figure 1. Dry weight vs. number of leaves for cultures of P. pectinatus grown at constant light and temperature conditions in 125 ml erlenmeyer flasks.

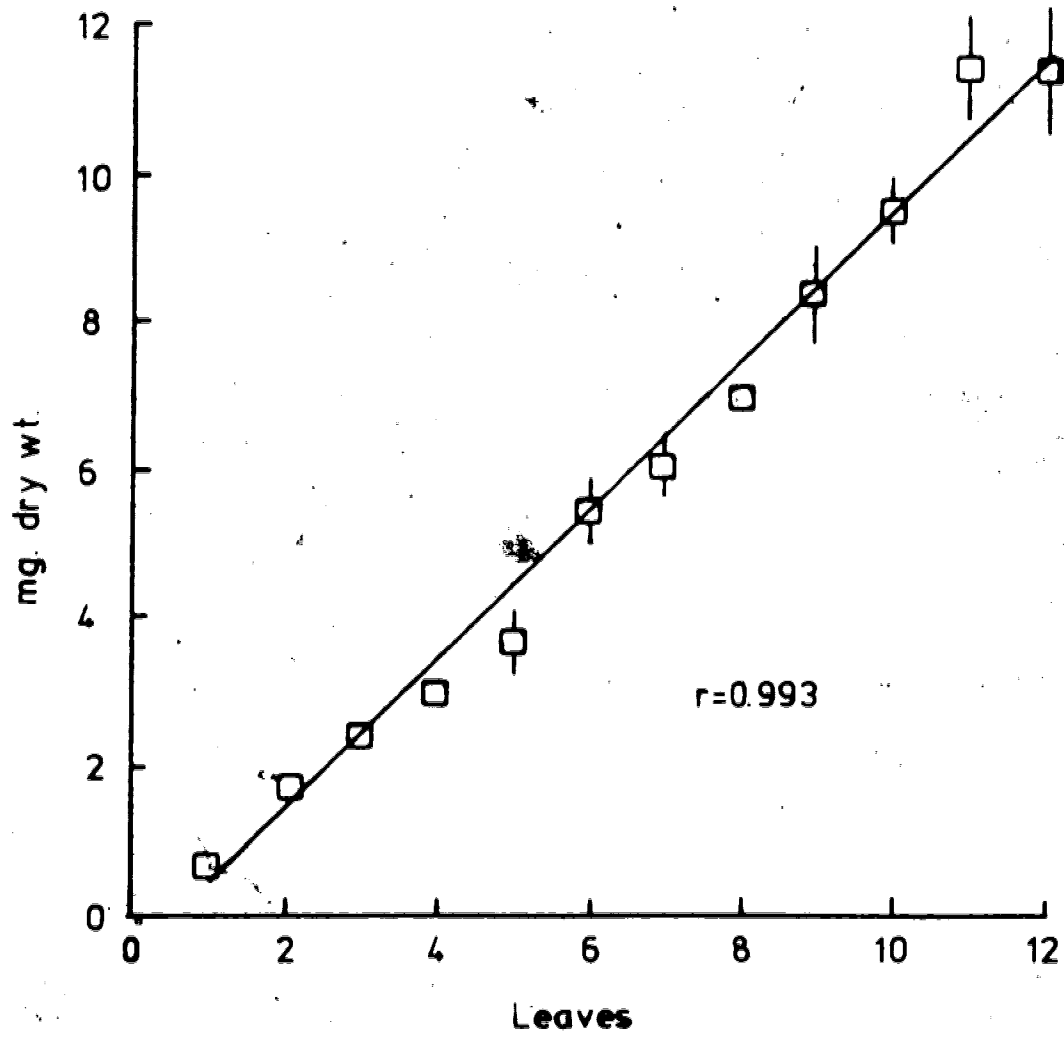

The water-phase media were replaced weekly in the pails to maintain test conditions. To monitor test conditions in the tanks, water-phase analyses were performed weekly for NO_3^- by the phenol-disulfonic acid method (Standard Methods, 1971), SO_4^{2-} by the turbidimetric method (Standard Methods, 1971), K^+ and Na^+ by flame photometry, Ca^{2+} and Mg^{2+} by atomic absorption, PO_4^{3-} by the molybdenum blue method of Mackereth (1973), pH by a Beckman model 72 meter, and conductivity and temperature by a YSI model 33 meter. In the tanks, water levels were maintained by addition of the filter-purified distilled water since the solutions were not changed. Tanks and pails were acid-washed and rinsed with the purified water between experiments.

After 35 days, the plants were harvested and separated into above- and below-ground portions. Both roots and shoots were then rinsed with distilled water, dried at 70°C for 24 hours and weighed. Ancillary data on flower production, shoot morphology and % plantlet survival were also reported. Oven-dried shoots were later ashed at 550°C for 1h to determine ash-free dry weight (% organic matter). The ash was then dissolved in 1 part HNO_3 to 4 parts water (Anderson, Brown and Rappleye, 1966) and analyzed for Ca^{2+} and Mg^{2+} by atomic absorption, Na^+ and K^+ by flame photometry, and PO_4^{3-} P by the ascorbic acid method (Standard Methods, 1971). A separate Kjeldahl digestion of dried plant material was used for analysis of total N. This was done by Chemical and Geological Laboratories in Edmonton.

Data were analyzed using Student's t-test except for analysis of variance done for Table 3 (sediment pasteurization effects) and Table 5 (sediment types). Standard Errors of the means are presented throughout.

RESULTS

The results are organized into four sections. The first is a validation of the method used in which the effects of sediment pasteurization on P. pectinatus L. growth and the efficacy of the sand barrier in separating the sedimentary nutrients from the water phase are examined. The second section consists of a nutrient survey in which the effects of removing specific water-phase nutrients on P. pectinatus growth and nutrient concentrations in the shoot are examined and compared to a standard nutrient formulation and a distilled water treatment. The third section is an examination of the importance that season, sediment, and inocula have in altering the results obtained in the preceding nutrient survey. In the fourth and final section there is a further elucidation of the nutrient survey results; the minimum water-phase nutrient requirements and the water-phase apoplastic calcium requirements of P. pectinatus are presented.

A brief summary of the water-phase chemical analyses is presented in Table 2. The measured amounts of absent nutrients were near or below the minimum levels of detection, or analytical zero, indicating a virtually complete lack of each of those nutrients in the water phase. Furthermore, the values in Table 2 were averages of determinations made throughout each 5-week test period as no noticeable changes in nutrient concentration occurred through any one experiment. The data from Table 2 indicate that the highly purified water, the 2.5-cm sand barrier, and the large water: sediment v/v ratios were effective in controlling both the initial water-phase nutrient concentrations and the nutrient concentrations throughout each test period.

TABLE 2

Water-phase chemical analyses in relation to experimental nutrient status. Means are based on 3 to 5 determinations.

Nutrient Status	Nutrient (ppm element)							Conductivity ($\mu\text{mhos. cm.}^{-1}$)
	$\text{PO}_4\text{-P}$	K	$\text{SO}_4\text{-S}$	Na	$\text{NO}_3\text{-N}$	Ca	Mg	
Standard (-P)	0.0	13.2	11.9	23.5	1.31	12.8	9.1	337
0	0.0	0.0	0.0	4.6	0.0	0.0	0.0	15
-P-N	0.0				0.0			344
-P-mf	0.0							340
-P-Mg	0.0						0.0	280
-P-S	0.0		0.0					280
-P-K	0.0	0.3						286
-P-Ca	0.0					0.4		256

¹ Minimum levels of detection (ppm): $\text{PO}_4\text{-P}$, 0.002; Na, K, 0.2; Ca, Mg, 0.1; $\text{NO}_3\text{-N}$, 0.02; $\text{SO}_4\text{-S}$, 0.2. Values ⁴ below these are reported as 0.0.

The effects of sediment pasteurization on the growth of P. pectinatus are reported in Table 3. There were no significant differences in biomass production between the four treatments. There were also no significant differences in shoot morphology, flower production, or survival rate between the four treatments.

Phosphorus was left out of the water phase in all treatments to control water-phase algal growth since Bole and Allan, 1978; Carignan and Kalff, 1980; and Barko and Smart, 1979, 1980, 1981 have conclusively proven that PO_4 can be adequately mobilized from the sediment by the roots for shoot requirements. The test with just P deleted from the water phase, designated -P in Table 4, is thus the standard for comparison. P. pectinatus plants grown in this standard -P water-phase solution impressively increased their biomass up to 250 times the initial weight in 35 days (Plate 5), a doubling time of approximately 4.5 days. The plants in the -P standard treatment were healthy with a shoot morphology much the same as those found in natural conditions except for a lack of noticeable epiphytic algae or marl encrustations. The plant growth was highly stoloniferous (Plate 6), allowed by the non-rigid sand barrier. Most of the plants flowered, producing an average 1.5 inflorescences g^{-1} (Figure 2), and grew to the water surface, 96 cm in the tanks, in the 5-wk incubation period. Eighty percent of the plantlets survived the initial planting in the -P standard test (Fig. 2).

In contrast to the -P standard was the distilled water treatment in which all nutrients were removed from the water phase, (designated "0" in Table 4). The biomass accrual was minimal in this treatment, no flowers were produced, and the plants appeared a pale green.

TABLE 3

Biomass production (mg. dry wt. \pm S.E.) of P. pectinatus in a standard -P nutrient solution in relation to conditions of sediment pasteurization. n = number of plants.

Pasteurization	Biomass (mg. dry wt. \pm S.E.)	n	Floral Clusters
1 x 60°C (Standard)	780 \pm 88	6	1
2 x 60°C	898 \pm 158	4	3
1 x 70°C	996 \pm 116	5	12
none	703 \pm 164	5	4

TABLE 4

Biomass (mg. dry wt. \pm S.E.) after five weeks growth in relation to water-phase nutrient status and season in which plants were grown.

Nutrient Status	Biomass (mg. dry wt. \pm S.E.)			
	Fall - Winter		Spring - Summer	
	Initial	Final	Initial	Final
-P	4.7	788 \pm 88	5.4	1361 \pm 136
0 ¹	4.6	19 \pm 3	4.4	11 \pm 2
-P-S ²	4.6	979 \pm 178	4.7	1185 \pm 129
-P-K	3.9	^a 358 \pm 56	4.3	1081 \pm 190
-P-Mg	4.7	^a 420 \pm 94	5.0	^a 440 \pm 81
-P-mi ³	4.2	733 \pm 138		
-P-N	5.3	648 \pm 80		
-P-Ca	4.4	* ⁴	5.0	* ⁴
AVG		546		1071

¹ Distilled water treatment.

² A "-" indicates the absence of a nutrient from the water-phase.

³ mi = Micronutrients.

⁴* = All plants died.

^a Values significantly less than lower (-P) standard and significantly greater than distilled water treatment at the 5% level using student's t-test.

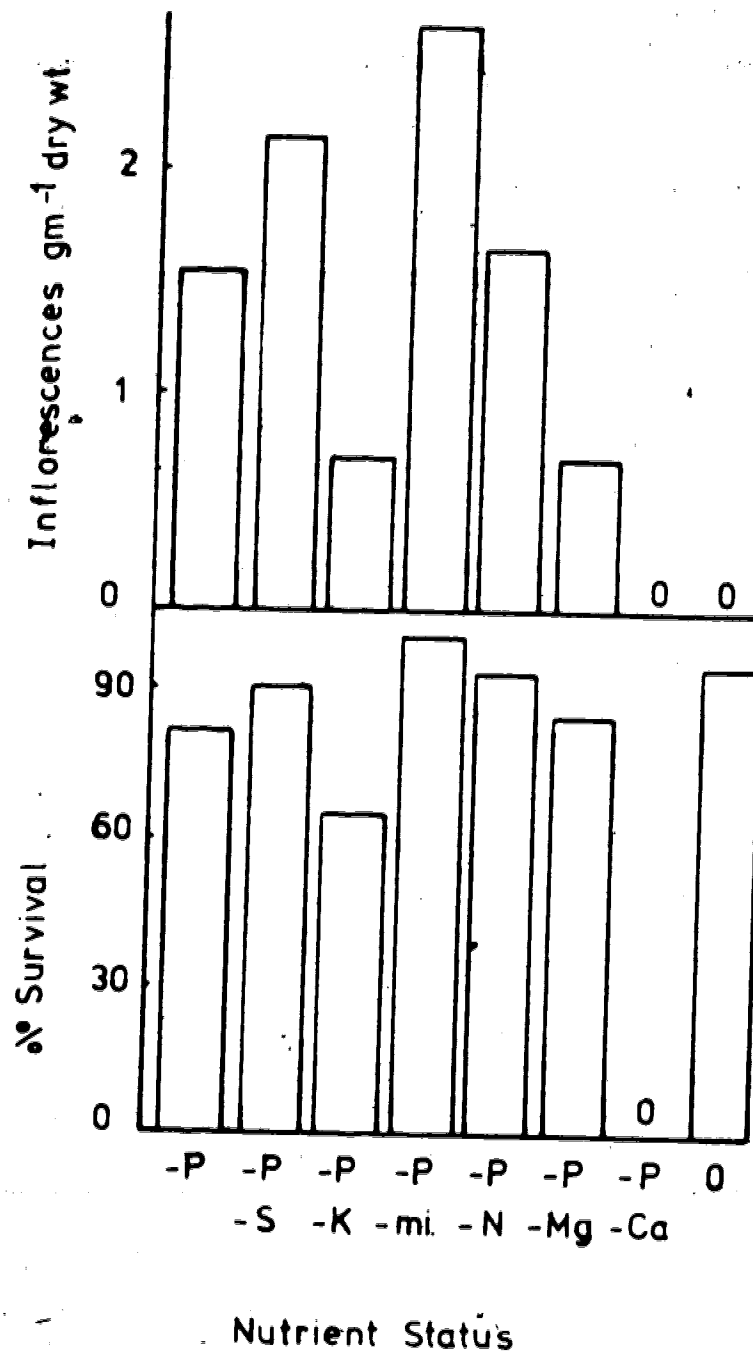

Plate 5. Plants of *P. pectinatus* in Styroware plastic cups containing Lake Wabuman sediment with a sand layer on top showing the transplant (left) and harvest (right) stages.



Plate 6. Typical young; established P. pectinatus transplant showing root development in sediment and stoloniferous growth habit..

Figure 2. Flower production and percent survival of P. pectinatus in relation to water-phase nutrient status.



There was, however, no decrease in % plantlet survival as compared to the -P standard.

The removal of N, S, or the micronutrients (mi) along with P from the water phase had no significant effect on plant biomass production (Table 4), flowering, plantlet survival (Fig. 2) or shoot morphology as compared to the -P standard. The removal of K from the water phase, however, did affect the growth of P. pectinatus. Biomass production was significantly less than the -P standard in one of two replicates (Table 4), though still significantly greater than the distilled water treatment. Flowering was also reduced, from an overall average of 1.6 inflorescences g^{-1} dry weight to a value of 0.6 (Fig. 2) and the survival rate of the plantlets decreased slightly from an average of 80% for the -P treatments to 64% for the -P-K treatment (Fig. 2). The shoot morphology of the plants in the -P-K treatment was the same as in the -P standard.

The removal of Mg from the water phase also affected growth. Biomass production was significantly less than the -P standard in both replicates though still greater than the distilled water treatment (Table 4). Flowering was reduced to 0.7 inflorescences g^{-1} dry weight, but plantlet survival was unaffected (Fig. 2), as was shoot morphology.

The removal of Ca from the water phase produced the most drastic effect on the P. pectinatus plantlets. In the -P-Ca treatment the plantlets died within 4-6 days of planting, turning dark brown and gradually disintegrating (Fig. 2, Table 4).

In addition to the cited biomass and related data, nutrient analyses of shoots were performed. Data are averages calculated in the presence (+) or absence (-) of specified nutrients (Figs. 3 and 4). These analyses provide, in conjunction with the preceding biomass data, an indication of the ability of the roots to mobilize nutrients which

Figure 3. Nutrient concentrations of P. pectinatus shoots grown under defined conditions for five weeks in the presence (+) and absence (-) of specified water-phase nutrients, compared to averages reported (1) by Hutchinson (1975) and critical concentrations reported (2) by Gerloff and Krombholz (1966).

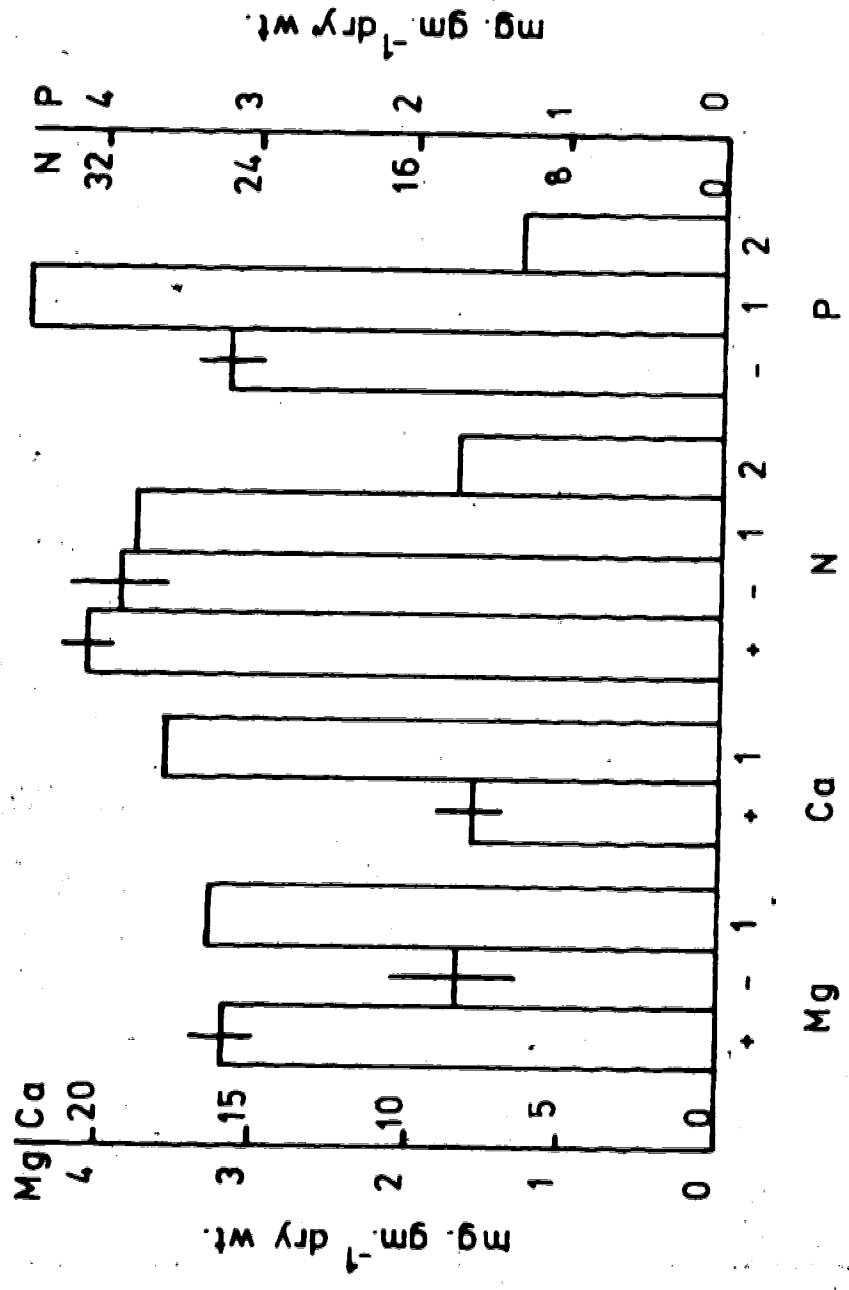
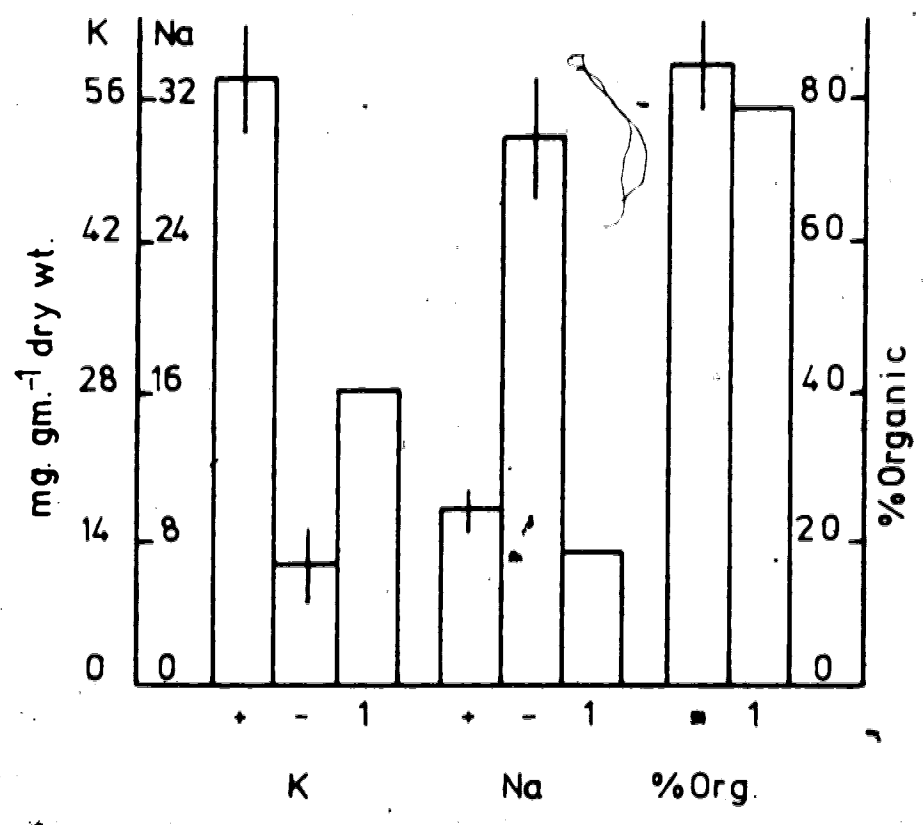

Figure 4. Nutrient concentrations of P. pectinatus shoots in the presence (+) and absence (-) of specified water-phase nutrients as compared to averages (1) reported by Hutchinson (1975). The % organic figure is an average for all treatments. The Na data is expressed in terms of the presence (+) or absence (-) of water-phase K.



are absent from the water phase to the shoots and also indicate possible effects of interactions among nutrients absent from the water phase and those still supplied on the resultant nutrient concentrations in the shoots.

The total P content of the shoots ranged from 2.2 to 4.8 mg g⁻¹ dry wt. for all treatments. The average content was 3.2 mg g⁻¹ (Fig. 3), somewhat lower than the value of 4.5 mg g⁻¹ reported by Hutchinson (1975), but well above the critical value of 1.3 mg g⁻¹ stated by Gerloff and Kromholz (1966). There were no consistent differences in total P content between treatments.

The total N values ranged from 25.7 - 35.2 mg g⁻¹ dry wt., the average being 31.1 mg g⁻¹ (Fig. 3). These values are very close to the average of 27.3 mg g⁻¹ reported for field-grown plants by Hutchinson (1975). There were no significant differences between treatments. All total N concentrations were well above the critical concentration of 13 mg g⁻¹ suggested by Gerloff and Kromholz (1966).

The % organic matter of the shoots ranged from 80.2 to 88.7 with an average of 85.5% (Fig. 4). This is close to the value of 79.9% reported by Hutchinson (1975) for field-grown plants. There were no consistent differences in % organic matter between treatments.

The range in shoot concentrations of Ca for all treatments was from 5.5 to 10.3 mg g⁻¹, but there were no consistent differences in Ca concentration between treatments. The average value was 7.9 mg g⁻¹ (Fig. 3), less than half the average of 17.0 mg g⁻¹ reported by Hutchinson (1975), which may be explained by the fact that Ca determinations are highly variable under natural conditions due to the problem of marl encrustation. There were no marl deposits visible on the

P. pectinatus plants in these experiments. No nutrient analyses were done for treatments lacking water-phase Ca as no plants survived in the -P-Ca treatment.

The concentration of Mg in the shoots varied from 1.4 to 4.1 mg g⁻¹ dry wt. with an average of 3.2 (Fig. 3). This is virtually the same as the average of 3.3 mg g⁻¹ reported for naturally grown plants (Hutchinson, 1975). Significantly, the lowest shoot Mg concentration was found for plants grown in the -P-Mg treatment. The average for the -P-Mg treatment of 1.7 mg g⁻¹ was just over half the average for all treatments (Fig. 3).

The shoot concentrations of K and Na varied from 2.4 to 72 mg g⁻¹ and 5.3 to 38.8 mg g⁻¹, respectively. An average of 25.9 mg g⁻¹ for K and 6.6 mg g⁻¹ for Na has been reported for naturally grown submerged macrophytes by Hutchinson (1975). The large variability of Na and K concentrations in the shoots were entirely consistent with the removal or addition of K to the water phase in which P. pectinatus plants were grown. The average shoot K and Na concentrations were 53.9 and 9.4 mg g⁻¹, respectively, for all treatments containing K in the water phase (Fig. 4). This shifted significantly to 10.6 mg g⁻¹ K and 30.0 mg g⁻¹ Na upon the removal of K from the water phase (Fig. 4). This becomes even more interesting when the K and Na shoot contents are expressed in mmoles g⁻¹ dry weight, whereupon the average shoot K and Na concentrations are 1.4 mmoles g⁻¹ and 0.4 mmoles g⁻¹, respectively for treatments containing water-phase K (Fig. 5) and 0.3 mmoles g⁻¹ and 1.3 mmoles g⁻¹, respectively for treatments lacking water-phase K. On a molar basis the K content of the shoots is largely replaced by Na ions when necessary to maintain a constant internal monovalent cation milieu.

Figure 5. Concentrations of Na and K ($\mu\text{moles g}^{-1}$) in shoots of P. pectinatus in the presence (+K) and absence (-K) of water-phase K.

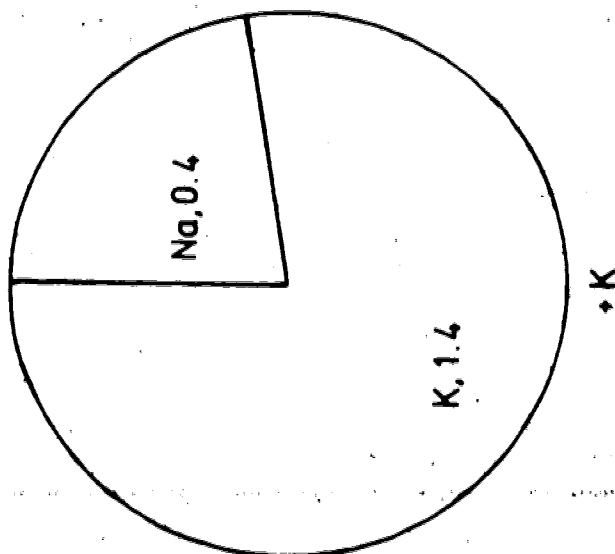
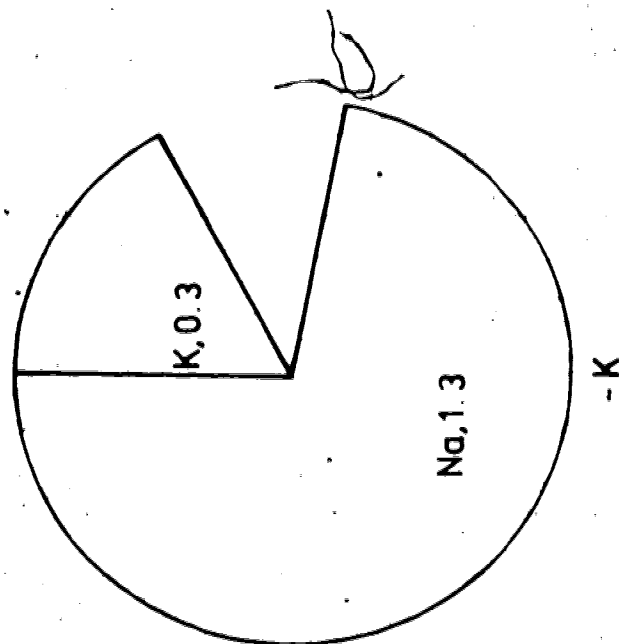

The degree to which the above nutrient survey results may have been altered by factors other than water-phase nutrient content, such as sediment, season, and inocula was of some interest.

There were significant differences between the biomass production of those plants grown the the fall-winter period and those grown in the spring-summer period (Table 4). The average biomass in the fall-winter period was only 50% of that produced in the spring-summer period (Table 4). These seasonal differences were consistent through two summers and two winters of experiments. They occurred even though the plantlets used for the experiments had been cultured under constant light and temperature conditions for more than a year and even though the experiments themselves were conducted under standard light and temperature conditions. Because of this seasonal periodicity only the fall-winter -P biomass of 780 mg (Table 4) was used as the standard for determining reductions in biomass production for the various treatments.

To determine if the nutrient survey results were in part sediment-related, three sediments were tested and compared using the -P-Ca and -P-K water-phase treatments. The sediments from Wabamun Lake (W.), J. Canal (J.C.) and Cooking Lake (Co.) differed widely in organic content (Table 1) with W. sediments being intermediate. W. sediment contained about twice the Ca of J.C. and Co. sediments and an intermediate amount of K which varied ten-fold between the three (Table 1). There were no obvious nutrient deficiencies in the three sediments.

For the -P-K treatment these were no significant differences in P. pectinatus biomass production among the three sediments, though there was a negative relationship between plant biomass and sediment

organic content as Barko (1982) has recently found (Table 1 and 5). After 5 weeks growth the plants in the -P-K treatment had reached the water surface of the tanks and produced flowers. Shoot morphology and survival rate were similar among the three sediments (Table 5) and indistinguishable from the plants in the -P standard treatment (Table 4). After ten weeks growth the plants had spread out in a mat on the water surface and had successfully produced seeds (Plate 7). The plants produced only 0.7 inflorescences g^{-1} dry weight, (Table 5), comparable to the value obtained for the -P-K treatments in Fig. 2. There were no large differences in flower production among the three sediments.

The removal of water-phase Ca proved toxic to P. pectinatus on all three sediments (Table 5), identical to the results in Table 4.

When the plantlets were replaced with large tubers as the inoculation material the response of P. pectinatus to the treatments -P, -P-Ca, 0 remained comparable to those in Table 4. For the standard -P treatment tuber-started plants produced a greater biomass but a smaller absolute increase (Table 6) than for plantlet -P treatments (Table 4). The tuber-started plants in the -P treatment, however, produced an amazing 295 inflorescences in only 5 weeks growth (Table 6). For the -P-Ca treatment the tuber-started plants eventually died as recorded in Tables 4 and 5 but there was a 3-wk lag time due to the stored reserves in the tubers. For the distilled water treatment the growth differences between the -P and 0 treatments in the tuber-started plants were evident after two weeks growth, a somewhat slower response than for the plantlet-started experiments. Subsequent plant growth in distilled water was minimal (Table 6).

TABLE 5

Biomass (mg. dry wt. \pm S.E.) production on three sediments for two water-phase nutrient conditions.

Nutrient Status	Sediment	Biomass (mg. dry wt. \pm S.E.)	Survival Rate	Floral Clusters
-P-Ca	W.	* ¹	0	
	Co.	*	0	
	J.C.	*	0	
² -P-K	W.	2956 \pm 591	0.8	11
	Co.	2081 \pm 612	0.8	4
	J.C.	3307 \pm 704	0.8	7

¹* = Indicates plant death.

²Grown ten weeks.



Plate 7. Fully mature *P. pectinatus* plants in fruiting stage after 7 weeks growth in a -P-K nutrient solution.

TABLE 6

Final biomass (mg. dry wt. \pm S.E.) after 5 weeks growth using tubers as inoculum material.

Nutrient Status	Biomass		n	Floral Clusters
	Initial (mg. fresh wt.)	Final (mg. dry wt.)		
-P	502	2406 \pm 83	10	295
-P-Ca	375	108 \pm 12 ¹	(10	
0	868	252 \pm 25	10	

¹Plants died three weeks after planting.

It is clear from these results that different seasons, and initial propagating materials produced a quantitative and not a qualitative difference in response of P. pectinatus plants to the water-phase nutrient status and that the nutrient survey results are in fact due to the water-phase nutrient formulations. The effects of using different sediments were negligible.

The most dramatic effects on P. pectinatus growth were produced by the removal of Ca from the water phase (Tables 4, 5, and 6) or by the removal of all nutrients from the water phase (Tables 4 and 6). It is evident that there are definite water-phase nutrient requirements for the growth and survival of P. pectinatus. Minimum water-phase nutrient requirements for normal growth of P. pectinatus are presented in Table 7. The reduction of all nutrients to one-tenth (0.1-P) that of the standard -P treatment reduced growth to that of the distilled water treatment. This was not a Ca effect since plants in 0.1-Ca-P treatment grew normally (Table 7). The significant difference between the -P and 0.1-P treatment was the reduced alkalinity and/or conductivity of the latter. Increasing just the alkalinity, however, (+NaHCO₃) improved growth only slightly. The further addition of Ca (+Ca, +NaHCO₃) improved biomass production to the level of the -P-Mg treatment (Tables 4 and 7) but still not to the level of the -P standard. Plant biomass production became statistically identical to that of the -P standard in the +Ca+Mg+NaHCO₃ treatment (Table 7). The further addition of K did not increase biomass production significantly, though an increase in flower production did occur (Table 7).

The role of conductivity, i.e. the water-phase electrochemical milieu, in the growth of P. pectinatus is somewhat more obscure than

TABLE 7

Minimum water-phase nutrient requirements. Biomass (mg. dry wt. \pm S.E.) after 5 weeks growth in relation to water-phase nutrient status.

Nutrient Status	Biomass (mg. dry wt. \pm S.E.)	Conductivity (μ mhos. cm^{-1})	Survival Rate	Floral Clusters
0	19 \pm 3	19	1.0	
0.1 ¹ -P	28 \pm 7	62	0.7	
-P 0.1 ¹ Ca	759 \pm 153	266	1.0	20
+NaHCO ₃ ²	^a 81 \pm 10	55	0.7	
+Ca +NaHCO ₃	^a 363 \pm 52	104	1.0	
+Ca+Mg +NaHCO ₃	615 \pm 113	217	1.0	1
+Ca+Mg+K +NaHCO ₃	810 \pm 91	280	0.9	10
Standard (-P)	780 \pm 88	337	0.8	1

^aValue significantly less than (-P) standard and significantly greater than distilled water treatment at the 5% level using student's t-test.

¹Nutrients added at 0.1 of the standard amount.

²A "+" indicates the addition of a nutrient to distilled water.

alkalinity since, with the addition of Ca, Mg and NaHCO_3 at standard levels, the conductivity was already over $200 \mu\text{mhos. cm}^{-1}$, a value reported by Seddon (1972) to be sufficient for the success of P. pectinatus. Such a conductivity was clearly adequate in this case.

The results in Table 4 indicate that the absence of water-phase Ca was toxic to the plants, but only in a full nutrient solution and not in the distilled water treatment.

The question of calcium toxicity is further reported in Table 8. In the -Ca-P and -Ca-K-P treatments the plants turned necrotic in 4-6 days and slowly disintegrated. In the -Ca-mi-P and -C-mi-K-P treatments the plants turned dark brown in 8-10 days and slowly disintegrated. However, in the -Ca-Mg-P treatment the P. pectinatus plants became bleached and disintegrated in less than seven days. Finally, in the -Ca-Mg-mi-P treatment the plants survived (Table 8), with a biomass production similar to the plants in the -P-Mg treatment (Table 4). This indicates that it is not the absence of Ca but the presence of toxic divalent cations in conjunction with the absence of Ca in the water phase that is inimical to the survival of P. pectinatus.

TABLE 8

The apoplastic calcium requirement. Biomass (mg. dry wt. \pm S.E.) after 5 weeks growth in relation to water-phase nutrient status.

Nutrient Status	Biomass (mg. dry wt. \pm S.E.)	n	Floral Clusters
Standard (-P)	773 \pm 72	10	13
-P-Ca	* ¹	10	
-P-Ca-K	*	10	
-P-Ca-mi ²	*	10	
-P-Ca-Mg	*	10	
-P-Ca-K-mi	*	10	
-P-Ca-Mg-mi	^a 321 \pm 59	10	

¹* = Indicates plant death.

²Micronutrients.

³A "-" indicates the absence of a nutrient from the water-phase.

^aSignificantly less than the -P standard at the 5% level using student's t-test.

DISCUSSION

Potamogeton pectinatus L., like many other submerged aquatic plants, is ecologically adapted to grow with its roots buried in the anaerobic sediment phase and its shoots submerged in the aerobic water phase. Mineral nutrients for the growth of these plants are potentially available from both the sediment and water phases. Determining which nutrients can be mobilized from the sediment by the roots and which must be absorbed by the shoots directly from the water phase is an important step in the understanding of several problem areas in aquatic research. Such knowledge is needed for the elucidation of nutrient cycling in aquatic systems, for a better understanding of nutrient-loading effects on macrophyte growth and macrophyte-algae interactions and for an explanation of observed correlations between water-phase nutrient status and macrophyte distribution.

The results presented indicate that the roots of P. pectinatus have differential mobilization abilities depending on the specific mineral nutrient in question. Phosphorus is one of the nutrients sufficiently mobilized by the roots of P. pectinatus from the sediment in the absence of water-phase phosphorus to support large increases in plant biomass (up to 250-fold in five weeks), abundant flower production, and normal seed development. These results are in agreement with those of Bole and Allan (1978); Carignan and Kalff (1980); and Barko and Smart (1979, 1980, 1981) whose findings not only indicate that submerged macrophytes can obtain needed phosphorus from the sediment but that even at hypereutrophic water-phase phosphate concentrations the majority of plant phosphorus comes from the sediment (Carignan

and Kalff, 1980). It is thus clear that submerged macrophytes, such as P. pectinatus, are protected from periods of phosphate depletion in the water phase that can occur and even contribute to the phosphorus content of the water-phase by mobilizing otherwise unavailable sediment phosphorus through uptake and subsequent plant injury and decay (Demarte and Hartman, 1974; Barko and Smart, 1980) or excretion (McRoy and Barsdate, 1972). The results also suggest that a prolonged increase in phosphorus loading of a body of water may have a deleterious effect on submerged macrophyte growth due to increased competition between macrophytes and benthic or planktonic algae for light and inorganic carbon.

Nitrogen, sulfur, and the micronutrients can also be sufficiently mobilized from the sediment to support normal growth of P. pectinatus in the absence of these nutrients from the water phase. Barko and Smart (1981) have obtained similar results for nitrogen, suggesting that root mobilization of nitrogen from the sediment is sufficient for shoot requirements. Nichols and Keeney (1976), however, using a slightly different approach, go further and suggest that submerged macrophytes are flexible about nitrogen uptake and will appropriate water-phase nitrogen in significant amounts when available. A critical study, such as that done by Carignan and Kalff (1980) for phosphorus, to determine the actual contribution of sediment nitrogen for macrophyte needs under natural conditions has not been done. However, the fact that water-phase nitrogen is second in demand only to water phase phosphorus in aquatic ecosystems (Wetzel 1975) suggests that the sediment would often be the principal source of nitrogen for these plants.

Less work has been done on the mobilization of sulfur and micro-nutrients by the roots of submerged aquatic plants. Cushing and Thomas (1980) have examined the availability of copper and zinc and have concluded that adequate amounts of these nutrients can be obtained from the sediment for plant requirements.

The consequences of removing potassium from the water-phase are somewhat more complicated. In this study, the roots of P. pectinatus mobilized sufficient potassium for normal biomass production from three different sediments with a ten-fold variation in potassium concentration. Barko and Smart (1981) and Barko (1982), however, found that on four of six sediments tested with several species of submerged macrophytes, absence of water-phase potassium caused significant reductions in biomass production. It appears that potassium mobilization from the sediment varies considerably with species as well as sediment. Nevertheless, in the absence of water-phase potassium a significant reduction in potassium concentration always occurred in the shoots of P. pectinatus and in the plants Barko and Smart (1981) and Barko (1982) tested. Furthermore, in the case of P. pectinatus, the loss of potassium ions was almost exactly compensated for by a gain in sodium ions. Barko and Smart (1981) and Barko (1982) did not analyze for sodium. These results suggest that there is a component of potassium content above that needed for normal biomass production whose function is sufficiently general to enable sodium ions to replace it if necessary and maintain a steady internal monovalent cation concentration. Such a general purpose requirement could be the regulation of osmotic potential and the neutralization of anions in the plant cells (Clarkson and Hanson, 1980). It is important to stress that submerged macrophytes

are probably never potassium-limited since both sediment- and water-phase potassium concentrations are naturally high and fluctuations, either biotic or manmade, unusual.

Magnesium is a nutrient clearly not mobilized from the sediment in sufficient quantities to satisfy shoot requirements. The absence of magnesium from the water-phase reduced the biomass production of P. pectinatus to about half the standard treatment. This water-phase magnesium requirement may be caused by the small absorptive surface area of roots found in aquatic macrophytes compounded by the fact that only a narrow sub-apical region of unsubsized root tissue is capable of divalent cation absorption (Ferguson and Clarkson, 1976) and by the slow acropetal flow in the xylem on which magnesium transport is relatively strongly dependent (Pitman, 1977).

The most dramatic effect on the survival of P. pectinatus occurred with the removal of calcium from the water phase which caused plant death in four to six days. This effect was prevented by the presence of 2 ppm calcium in a full nutrient solution or by the removal of all divalent cations from the water phase, including calcium. There is thus an apoplastic calcium requirement that cannot be satisfied by mobilization of calcium from the sediment caused, at least in part, by toxic divalent cations. The first documentation of such an external calcium requirement was by Epstein (1960), using excised barley roots. More recently, Clarkson and Hanson (1980), in a review, state that calcium is the major cation in the protein-pectin cement of the middle lamella and is essential to the maintenance of membrane integrity and ion selectivity. Calcium has also been implicated in specific binding to the HCO_3^- transport enzyme as a cofactor (Lucas and Dainty, 1980).

Most importantly, Epstein (1972) has suggested that the greater the toxic cation concentration the greater is the necessary apoplastic calcium concentration. The results presented here are consistent with this hypothesis and imply a competitive interaction between calcium and other divalent cations for the above-mentioned binding site on the membrane and otherwise. In the case of P. pectinatus these toxic ions are the micronutrients and magnesium.

The results of this study have implications for lake acidification, which solubilizes significant quantities of micronutrients from the sediment. If, as Epstein (1972) suggests, the apoplastic calcium concentration requirement depends on the concentration of the other toxic ions, such an increase in micronutrient cations could prove toxic by the displacement of calcium from essential sites in the apoplasm. The addition of Ca_3CO_3 would prove doubly effective in counteracting this problem by decreasing the H^+ concentration and increasing the calcium concentration, thereby increasing the competitive ability of the calcium for apoplastic sites on submerged macrophytes.

One of the most dramatic reductions in P. pectinatus biomass production occurred with the removal of a significant DIC pool from the water phase. The roots are not able to supply the shoots with any appreciable inorganic carbon from the sediment. This confirms the earlier work of Martin, Bradford, and Kennedy (1970) who found that Najas flexilis must obtain its inorganic carbon from the water phase.

These results suggest that the causative factor in the exclusion of hardwater species from softwater of low alkalinity is primarily the water phase DIC requirement and possibly the low calcium and magnesium concentrations. Species that do exist in oligotrophic waters of low

alkalinity have three morphological adaptations which overcome the problem of calcium, magnesium, and HCO_3 transport from the sediment. A typical softwater species such as Lobelia dortmanna L. has a large root biomass aided by vesicular-arbuscular (VA) fungal associations (Sondergaard and Laegaard, 1977) and a short, telescoped stem. They also develop a significant aerenchymous network sufficient for large-scale CO_2 transport (Wlum-Anderson, 1971). It would be interesting to extend the work with P. pectinatus to the examination of Lobelia dortmanna and determine if there are any water-phase nutrient requirements for this species.

One further observation, not strictly connected to the biphasic mineral nutrition of P. pectinatus, is the striking seasonal periodicity observed in the production of P. pectinatus biomass. Production in plants cultured in the fall-winter was slightly more than half of the production of those cultured in the spring-summer, even though the plants were totally separated from the external environment. This occurred in the tank experiments after the stock cultures had been growing in constant light and temperature conditions for over one year and continued through two summers and two winters of experiments. There were no changes in L:D ratios or temperature throughout the experimental period and no external light or temperature environmental cues. Though this is not conclusive evidence it certainly does suggest that there is an internal seasonal periodicity in the growth of P. pectinatus independent of obvious external environmental cues.

To summarize, therefore, this study has shown that the roots of Potamogeton pectinatus are capable of mobilizing sufficient phosphorus, nitrogen, sulfur, and micronutrients from the sediment to the shoots (Fig. 6)

to meet normal growth requirements under the experimental conditions. Potassium is also sufficiently mobilized from the sediment by the roots to fulfill growth requirements but not in sufficient amounts to satisfy a more generalized additional requirement that is probably related to anion neutralization and maintenance of osmotic potential. In the absence of potassium from the water phase, this ancillary requirement appears to be adequately replaced by sodium, although the vigor of the plants may suffer somewhat by the exchange. The roots of P. pectinatus are not capable of mobilizing sufficient magnesium, (Fig. 6) calcium or any inorganic carbon from the sediment to the shoots to meet normal growth requirements. The presence of 2 ppm calcium, 10 ppm magnesium, and 0.5 meq. HCO_3 in the water phase will permit normal growth to proceed. In addition, water-phase calcium is necessary to prevent the toxicity of other divalent cations present in the water-phase to P. pectinatus plants.

Figure 6. The ability of P. pectinatus to mobilize nutrients. P, N, S, K and Mn can be completely supplied to the shoots from the sediment (solid arrows). Ca and Mg must be at least partially supplied to the shoots from the water phase (dashed arrows). DIC must be supplied completely from the water phase to the shoots (solid arrow). K (or Na) must be supplied from the water phase to maintain internal cation concentrations (clear arrow).

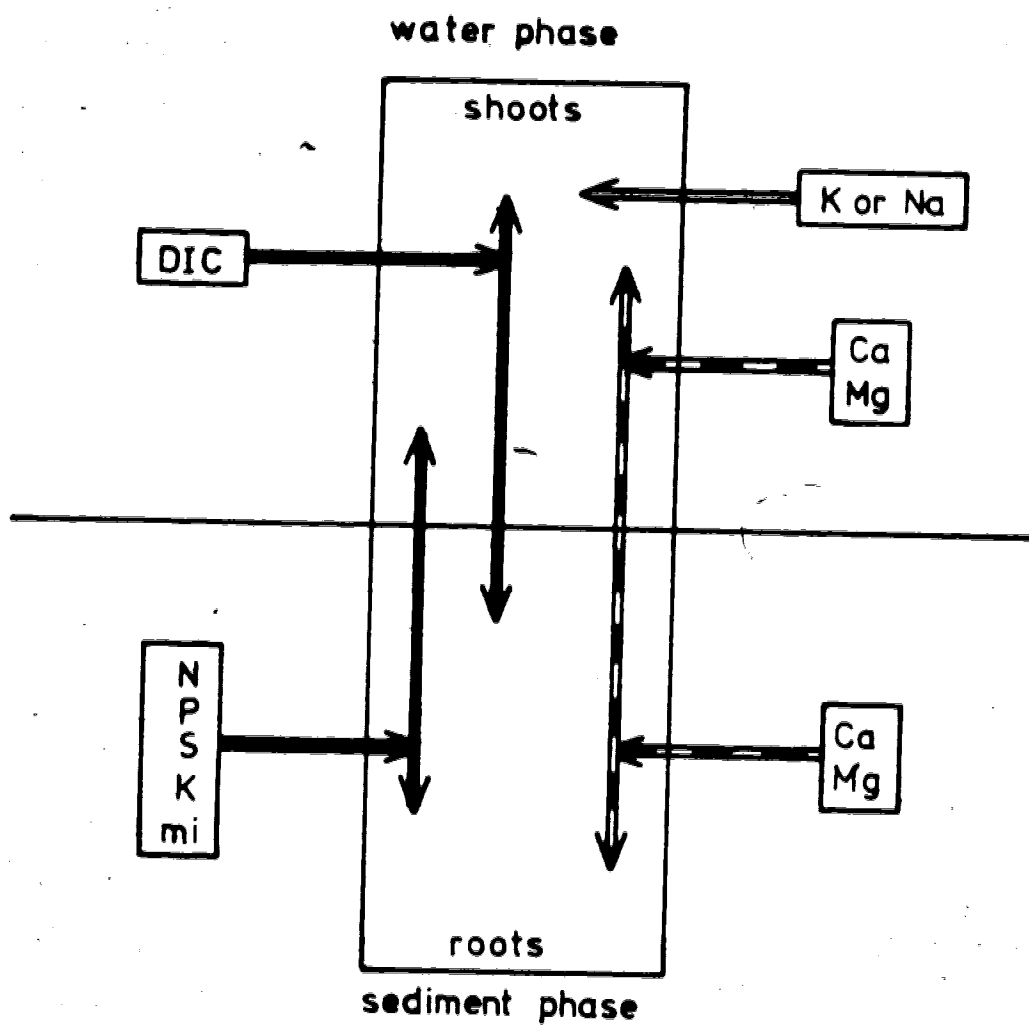

LITERATURE CITED

- American Public Health Association (APHA). 1971. Standard methods for the examination of water and wastewater. 13 ed. Washington, D.C.
- Anderson, R.R., R.G. Brown, and R.D. Rappleye. 1966. The mineral content of Myriophyllum spicatum L. in relation to its aquatic environment. *Ecology* 47(5): 844-846.
- Arber, A. 1920. Water Plants: A Study of Aquatic Angiosperms. Cambridge University Press, London.
- Barko, J.W. 1982. Influence of potassium source (sediment vs. open water) and sediment composition on the growth and nutrition of a submersed freshwater macrophyte. *Aquatic Botany* 12: 157-172.
- Barko, J.W. and Smart, R.M. 1979. The role of Myriophyllum spicatum in the mobilization of sediment phosphorus. In: Aquatic Plants, Lake Management and Ecosystem Consequences of Lake Harvesting. (Ed. by J.E. Breck, R.T. Prentko, O.L. Loucks). Institute for Environmental Studies, U of Wisconsin-Madison.
- Barko, J.W. and Smart, R.M. 1980. Mobilization of sediment phosphorus by submersed freshwater macrophytes. *Freshwater Biol.* 10: 229-238.
- Barko, J.W. and Smart, R.M. 1981. Sediment-based nutrition of submersed macrophytes. *Aquat. Bot.* 10: 339-352.
- Bole, J.B. and Allan, J.R. 1978. Uptake of phosphorus from sediment by aquatic plants, Myriophyllum spicatum and Hydrilla verticillata. *Water Research* 12: 353-358.
- Bourn, W.S. 1932. Ecological and physiological studies on certain aquatic angiosperms. *Contr. Boyce Thompson Inst.* 4: 425-496.
- Bristow, J.M. and Whitcombe, M. 1971. The role of roots in the nutrition of aquatic vascular plants. *Amer. J. Bot.* 48: 8-13.
- Brown, W.H. 1913. The relation of the substratum to the growth of Elodea. *The Phillipine Jour. of Science* 8(1): 1-20.
- Carignan, R. and Kalff, J. 1980. Phosphorus sources for aquatic weeds: water or sediments? *Science* 207: 987-989.
- Clarkson, D.T. and Hanson, J.B. 1980. The mineral nutrition of higher plants. *Ann. Rev. Plant Physiol.* 31: 239-298.
- Cole, B.S. and Toetz, D.W. 1975. Utilization of sedimentary ammonia by Potamogeton nodosus and Scirpus. *Verh. Internat. Verein. Limnol.* 19: 2765-2772.

- Cushing, C.E. and Thomas, J.M. 1980. Cu and Zn kinetics in Myriophyllum heterophyllum. Mich. and Potamogeton richardsonii (A.R. Benn) Rydb. Ecology 61(6): 1321-1326.
- Demarte, J.A. and Hartman, R.T. 1974. Studies on absorption of ^{32}P , ^{59}Fe and ^{45}Ca by water-milfoil (Myriophyllum exalbescens Fernald).. Ecology 55: 188-194.
- Denny, P. 1972. Sites of nutrient absorption in aquatic macrophytes. J. Ecol. 60: 819-829.
- Epstein, E. 1960. The essential role of calcium in selective cation transport by plant cells. Plant Phys. 36: 437-444.
- Epstein, E. 1972. Mineral Nutrition of Plants: Principles and Perspectives. John Wiley and Sons, Inc. Toronto.
- Ferguson, I.B. and Clarkson, D.T. 1976. Simultaneous uptake and translocation of magnesium and calcium in barley (Hordeum vulgare L.) Roots. Planta 128: 267-269.
- Frank, P.A. and R.H. Hodgson. 1964. A technique for studying absorption and translocation in submersed plants. Weeds 12: 80-82.
- Gentner, S.R. 1977. Uptake and transport of iron and phosphate by Vallisneria spiralis L. Aquat. Bot. 3: 267-272.
- Gerloff, G.C. and Krombholz, P.H. 1966. Tissue analysis as a measure of nutrient availability for the growth of angiosperm aquatic plants. Limnol. and Oceanog. 11: 529-537.
- Hutchinson, G.E. 1975. A Treatise on Limnology III. Limnological Botany. John Wiley and Sons, New York.
- Hynes, H.B.N. and Grieb, B.J. 1970. Movement of phosphate and other ions from and through lake muds. J. Fish. Res. Bd. Can. 27: 653-668.
- Jeschke, W.D. 1970. Influx von Kaliumionen bei Blättern von Elodea densa, Abhängigkeit von Licht, von der Kaliumionenkonzentration und von der Temperatur. Planta 91: 111-128.
- Jeschke, W.D. and Simonis, W. 1965. On the uptake of phosphate and sulphate ions by leaves of Elodea densa as influenced by light, temperature, and external concentration. Planta 67: 6-32.
- Lucas, W.J. and Dainty, J. 1977. HCO_3^- influx across the plasmalemma of Chara corallina. Divalent cation requirement. Plant Physiology 60: 862-867.

- Mackereth, F.J.H. 1963. Some methods of water analysis for limnologists. Freshwat. Biol. Assoc. Publication no 21.
- Martin, J.B., Bradford, B.N. and Kennedy, H.G. 1970. Factors affecting the growth of Najas in Pickwick reservoir. National Fertilizer Center, T.V.A., Muscle Shoals, Alabama.
- McRoy, C.P. and Barsdate, R.J. 1970. Phosphate absorption in eelgrass. Limnol. and Oceanog. 15: 6-13.
- Mickle, A.M. 1975. The comparative mineral nutrition of nuisance aquatic plants. Ph.D. Thesis, Univ. Wisconsin.
- Moyle, J.B. 1945. Some chemical factors influencing the distribution of aquatic plants in Minnesota. The Amer. Mid. Nat. 34: 402-420.
- Mulligan, H.F. and Baranowski, A. 1969. Growth of phytoplankton and vascular aquatic plants at different nutrient levels. Verh. Internat. Verein. Limnol. 17: 802-810.
- Mulligan, H.F., Baranowski, A., and Johnson, R. 1969. Growth of vascular plants and algae in fertilized ponds. Int. Bot. Congr. 11th, Seattle, Washington.
- Mulligan, H.F., Baranowski, A. and Johnson, R. 1976. Nitrogen and phosphorous fertilization of aquatic vascular plants and algae in replicated ponds. I. initial response to fertilization. Hydrobiologia 48: 109-116.
- Nichols, D.S. and Keeney, D.R. 1976. Nitrogen nutrition of Myriophyllum spicatum: uptake and translocation of ^{15}N by shoots and roots. Freshwater Biology 6: 145-154.
- Pip, E. 1979. Survey of the ecology of submerged aquatic macrophytes in central Canada. Aquat. Bot. 7: 339-357.
- Pitman, M.G. 1977. Ion transport into the xylem. Ann. Rev. Plant Physiol. 28: 71-88.
- Pond, R.H. 1905. The biological relation of aquatic plants to the substratum. U.S. Commission of Fish and Fisheries Part XXIX, page 483-526.
- Pringsheim, E.G. and Pringsheim, O. 1962. Axenic culture of Utricularia. Amer. J. Bot. 49(8): 898-901.
- Schults, D.W. and Malueg, K.W. 1971. Uptake of radiophosphorous by rooted aquatic plants. National Symposium on Radioecology, 3rd, Oak Ridge.
- Sculthorpe, C.D. 1967. The Biology of Aquatic Vascular Plants. Edward Arnold Ltd., London.

- Seddon, B. 1972. Aquatic macrophytes as limnological indicators. *Freshwat. Biol.* 2: 107-130.
- Shannon, E.L. 1953. The production of root hairs by aquatic plants. *Amer. Midland Naturalist* 50(2): 474-479.
- Smith, C.S. 1978. Phosphorous uptake by roots and shoots of Myriophyllum spicatum L. The University of Wisconsin-Madison, Ph.D. thesis.
- Snell, K. 1908. Untersuchungen über die Nahrungsaufnahme der Wasserpflanzen. *Flora* 98: 213-249.
- Sondergaard, M. and Laegaard, S. 1977. Vesicular-arbuscular mycorrhiza in some aquatic vascular plants. *Nature* 269: 232-233.
- Spence, D.H.N. 1967. Factors controlling the distribution of freshwater macrophytes with particular reference to the lochs of Scotland. *J. Ecol.* 55: 147-170.
- Toetz, D.W. 1973. The kinetics of NH_4 uptake by Ceratophyllum. *Hydrobiol.* 41: 275-290.
- Toetz, D.W. 1974. Uptake and translocation of ammonia by freshwater hydrophytes. *Ecology* 55: 199-201.
- Twilley, R.R., Brinson, M.M., and Davis, G.J. 1977. Phosphorous, absorption, translocation, and secretion in Nyphar luteum. *Limnol. and Oceanog.* 22: 1022-1032.
- Welsh, R.P.H. and Denny, P. 1979. The translocation of ^{32}P in two submerged aquatic angiosperm species. *New Phytol.* 82: 645-656.
- Wetzel, R.G. 1975. Limnology. W.B. Saunders Company, Toronto.
- Wetzel, R.G. and McGregor, D. 1968. Axenic culture and nutritional studies of aquatic macrophytes. *Amer. Midland Naturalist* 80(1): 52-64.
- Wetzel, R.G. and Manny, B.A. 1972. Secretion of dissolved organic carbon and nitrogen by aquatic macrophytes. *Verh. Internat. Verein. Limnol.* 18: 162-170.
- Wium-Anderson, S. 1971. Photosynthetic uptake of free CO_2 by the roots of Lobelia dortmanna. *Physiol. Plant.* 25: 245-248.

APPENDIX

The nutrient formulation modified from Pringsheim and Pringsheim (1962)
used in the monophasic stock cultures of P. pectinatus.

<u>Nutrient</u>	<u>Composition</u>
KNO ₃	0.02%
(NH ₄) ₂ HPO ₄	0.002%
MgSO ₄ ·7H ₂ O	0.001%
CaSO ₄ (saturated)	2ml/100ml
Minor element solution	1ml/100ml
TRIS	0.1g/l

Minor Element Solution

<u>Nutrient</u>	<u>Composition %</u>
EDTA	0.02
FeSO ₄ ·7H ₂ O	0.07
ZnSO ₄ ·7H ₂ O	0.001
MnSO ₄ ·4H ₂ O	0.0002
CuSO ₄ ·5H ₂ O	0.0001
H ₃ BO ₃	0.001
Co(NO ₃) ₂ ·6H ₂ O	0.0001
Na molybdate·2H ₂ O	0.0001

pH 8.0 - 8.2