

# DEPARTMENT OF ANTHROPOLOGY LIBRARY

THE UNIVERSITY OF ALBERTA

## RELEASE FORM

NAME OF AUTHOR GREGORY MARK LATHROP .....

TITLE OF THESIS A SOLUTION TO THE CROW-OMAHA PROBLEM AND ITS  
.....  
IMPLICATIONS FOR FUTURE RESEARCH INTO SOCIAL  
.....  
ORGANIZATION .....

DEGREE FOR WHICH THESIS WAS PRESENTED MASTER OF ARTS .....

YEAR THIS DEGREE GRANTED 1978 .....

Permission is hereby granted to THE UNIVERSITY OF ALBERTA LIBRARY to reproduce single copies of this thesis and to lend or sell such copies for private, scholarly or scientific research purposes only.

The author reserves other publication rights, and neither the thesis nor extensive extracts from it may be printed or otherwise reproduced without the author's written permission.

(Signed) *Mark Lathrop* .....

PERMANENT ADDRESS:

7334 118A Street  
.....  
Edmonton, Alberta  
.....  
.....

DATED... *July* ..... 1977

THE UNIVERSITY OF ALBERTA

A SOLUTION TO THE CROW-OMAHA PROBLEM  
AND ITS IMPLICATIONS FOR FUTURE RESEARCH  
INTO SOCIAL ORGANIZATION

by



GREGORY MARK LATHROP

A THESIS

SUBMITTED TO THE FACULTY OF GRADUATE STUDIES AND RESEARCH  
IN PARTIAL FULFILMENT OF THE REQUIREMENTS FOR THE DEGREE  
OF MASTER OF ARTS

DEPARTMENT OF ANTHROPOLOGY

EDMONTON, ALBERTA

SPRING, 1978

UNIVERSITY OF ALBERTA

FACULTY OF GRADUATE STUDIES AND RESEARCH

The undersigned certify that they have read, and recommend to the Faculty of Graduate Studies and Research, for acceptance, a thesis entitled "A Solution to the Crow-Omaha Problem and its Implication for Future Research into Social Organization" submitted by Gregory Mark Lathrop in partial fulfilment of the requirements for the degree of Master of Arts.

*Michael A. Mad...*

Supervisor

*Robert S. Key*

*Kenneth Morgan*

July, 1977

## ABSTRACT

This thesis presents a solution to the Crow-Omaha problem as originally defined by Levi-Strauss (1966, 1969). By beginning with a set of fixed demographic conditions and a given form of Crow-Omaha marriage rules, and viewing the clan structure as being in a non-equilibrium state, it is possible to overcome the demographic problems which hampered Levi-Strauss' analysis of the Crow-Omaha systems. In particular, it is shown that in a finite and endogamous population demographic variation under Crow-Omaha exchange causes an imbalance in the size of clans and an actual reduction in clan numbers culminating in the convergence of the exchange system to a minimal structure with mechanical properties determined solely by the marriage rules. This result is independent of the initial pattern of exchange assumed in the analysis, or the particular demographic history of the population, the problems which originally impeded Levi-Strauss. The properties of the minimal structure can be used to explain several other features of Crow-Omaha societies, most importantly patterns of migration and clan fissioning. The results obtained here bear on the general theoretical question of the relationship between demographic and social variables, and suggest a direction for future research into problems of social organization.

The analysis presented in this thesis is framed within the context of Navajo ethnography. Navajo social organization is not usually classified as Crow-Omaha because the kinship system is Iroquoian and clans are not corporate units. From the viewpoint of exchange, however, the Navajo system may actually be thought of as an ideal Crow-Omaha type, since the clans function almost exclusively in the regulation of marriage. By using the Navajo example in an initial analysis, any possible devia-

tions from Levi-Strauss' model caused by clan hierarchization can be avoided.

The effects of the convergence of the exchange structure within Navajo communities is examined by a comparison between ethnographic data and the results of computer simulations. A statistical tendency for marriage into one of the grandfathers' clans and the pattern of migration into Navajo communities are explained on the basis of the properties of the minimal exchange structure.

## ACKNOWLEDGMENTS

I would like to acknowledge the assistance of my thesis committee in making the completion of this work possible. Michael Asch first introduced me to the problem, and his theoretical influence, expressed to me both in lectures and in discussion, pervades this thesis. Insofar as the model developed here has relevance to social anthropology, it can be traced to this source.

Ken Morgan spent many hours modifying his simulation program for my use, provided the theoretical methods for the statistical analysis, and gave me access to his fieldnotes on Ramah. Any misuse of this assistance or other errors in this work are my sole responsibility.

TABLE OF CONTENTS

	<u>Page</u>
CHAPTER ONE . . . . .	1
CHAPTER TWO . . . . .	15
CHAPTER THREE . . . . .	40
CHAPTER FOUR . . . . .	68
CHAPTER FIVE . . . . .	79
APPENDIX I . . . . .	86
APPENDIX II . . . . .	90
APPENDIX III . . . . .	94
APPENDIX IV . . . . .	106
BIBLIOGRAPHY . . . . .	115

FIGURES AND TABLES

	<u>Page</u>
Table 2.1	The Basic Adult Founding Population at Ramah . . . . . 24
Fig 2.1a	Clan Size at Shiprock: 1925 . . . . . 26
Fig 2.1b	Marriages at Shiprock: 1925 . . . . . 27
Fig 2.2a	Clan Size at Lukachukai: 1925 . . . . . 28
Fig 2.2b	Marriages at Lukachukai: 1925 . . . . . 29
Fig 2.3a	Clan sizes at Keam's Canyon: 1925 . . . . . 30
Fig 2.3b	Marriages at Keam's Canyon: 1925 . . . . . 31
Fig 2.4a	Clan sizes at Ganado: 1925 . . . . . 32
Fig 2.4b	Marriages at Ganado: 1925 . . . . . 33
Fig 2.5a	Clan Sizes at Chinlee: 1925 . . . . . 34
Fig 2.5b	Marriages at Chinlee: 1925 . . . . . 34
Fig 2.6a	Clan Sizes at Navajo Mountain: 1961 . . . . . 35
Fig 2.6b	Marriages at Navajo Mountain: 1961 . . . . . 36
Fig 2.7a	Clan Sizes at Ramah: 1964 . . . . . 37
Fig 2.7b	Marriages at Ramah: 1964 . . . . . 38
Table 2.2	Clan distribution in seven Navajo communities . . . . . 39
Fig 3.1	Equilibrium Model of the Minimal Structure . . . . . 54
Fig 3.2a	Population Growth in Endogamous Runs: initial population of 24 . . . . . 56
Fig 3.2b	R Levels for Maximal Growth Endogamous Runs in 3.2a . . . . . 57
Fig 3.3a	Population Growth in Endogamous Runs: initial population of 50 and 100 . . . . . 58
Fig 3.3b	R Levels for Maximal and Minimal Growth Runs in 3.3a . . . . . 60
Fig 3.4a	Comparison of Minimal Structure with Reciprocal Exchange . . . . . 61
Fig 3.4b	R Levels for Maximum Growth Runs under each rule in Fig 3.4a . . . . . 62



	<u>Page</u>
Fig 3.5 Population Growth and R Values in Typical Migration Runs . . . . .	63
Fig 3.6a Clan Distribution in a Typical Endogamous Run: Rule 2 and initial population of 100 . . . . .	64
Fig 3.6b Clan Distribution in a Typical Endogamous Run: Rule 1 and initial population of 50 . . . . .	65
Fig 3.7a Clan Distributions at Ending Year in Typical Migration . . . . .	66
Fig 3.7b Clan Distributions at Various Years in a Typical Migration . . . . .	67
Table 4.1 Marriage Types and Clan Groups at Keam's Canyon: 1925 . . . . .	74
Table 4.2 Marriage Types and Clan Groups at Ganado: 1925. . . . .	74
Table 4.3 Marriage Types and Clan Groups at Chinlee: 1925 . . . . .	74
Table 4.4 Marriage Types and Clan Groups at Lukachukai:1925 . . . . .	75
Table 4.5 Marriage Types and Clan Groups at Shiprock: 1925 . . . . .	75
Table 4.6 Marriage Types at Navajo Mountain: 1961 . . . . .	76
Table 4.7 Marriage Types at Ramah: 1964 . . . . .	77
Table 4.8 Statistical Analysis of Clan Group Data . . . . .	78
Fig A1.1 Demographic Schedules used in the Simulation . . . . .	89
Fig A3.1 System of Iroquoian Terminology. . . . .	101
Fig A3.2 Generational Merging Kinship Terminology. . . . .	102
Fig A3.3a Extended Kinship Terminology:Maternal side . . . . .	103
Fig A3.3b Extended Kinship Terminology:Paternal side . . . . .	104
Table A3.1 Explanation for the Kinship Variation in Fig 4.3 . . . . .	105
Fig A4.1 Pattern of Outfit Division implied in the Developmental Cycle Model . . . . .	112
Fig A4.2 The Result of Internal Alliance . . . . .	113
Fig A4.3 A Portion of the Reciprocal Alliance Pattern in Ramah . . . . .	114

## CHAPTER ONE

In his article, The Future of Kinship Studies, Levi-Strauss has written that:

Kinship systems consist....of two types of objects equally real: the actual working of the system within a given society on the one hand, and on the other, a model, that is a set of rules. Since the latter may not coincide with the former and even perhaps contradict it, the study of the model should be given logical priority over its empirical applications. (Levi-Strauss 1966:16)

In 1949, the application of this theoretical viewpoint led Levi-Strauss to the publication of Les Structures Elementaires de la Parente, a work justly famous for its seminal insights into the relationship between the theoretical and actual operation of elementary systems of exchange. The debt owed to Levi-Strauss for the elucidation of the structural principles which underly empirical patterns of exchange in these systems is widely recognized (cf. Leach 1964; Needham 1962). By 1966, however, a fundamental shift was obvious in the nature of Levi-Strauss' research. Although still encompassed within the same theoretical viewpoint, the priority originally assigned to the analysis of models of social organization had been transformed into a nearly exclusive concentration on the ideology of kinship and marriage, and hence mythology. Except for the introduction to the second edition of his major work, published in English as the Elementary Structures of Kinship in 1969, Levi-Strauss has since written almost exclusively on the latter topic. It behooves those who seek a different future for the anthropological study of kinship, and who desire to achieve further insight into both the theoretical and empirical nature of social organization, to fully understand the reasons for Levi-Strauss' retreat from these problems into mythology. Fortunately, his

reasons are made explicit in the 1966 article, and again in the 1969 preface.

According to Levi-Strauss, the "problem which blocks entirely the path ahead of us....[is that] raised by the so-called Crow-Omaha kinship systems"(1966:18).<sup>1</sup> Because Crow-Omaha exchange occupies a strategic position between elementary and complex structures, the analysis of the Crow-Omaha systems is essential for the extension of structural methods to more general forms of exchange. However, the model of Crow-Omaha exchange originally proposed by Levi-Strauss led to certain demographic problems which he ultimately concluded were insurmountable. Indeed, Levi-Strauss apparently abandoned the structural study of marriage exchange primarily because of the nature of the Crow-Omaha problem. I will show that by considering demography as an initial condition for the development of a model of Crow-Omaha exchange rather than as a derivative problem, a structural analysis of these systems is in fact possible. Because this solution links the theory of Crow-Omaha exchange to empirical patterns of social organization, it extends the original program of analysis proposed by Levi-Strauss.

1. The Structural Model of Crow-Omaha Exchange

Levi-Strauss' program established a series of logically separable categories of marriage exchange, with one pole encompassing elementary systems and the other complex structures. Elementary systems are characterized by the co-existence of unilineal descent and positive, or prescriptive, rules of marriage. In theory, these rules specify a category of kinship from within which all marriage choices must be made. Previous to Levi-Strauss' structural analysis, such a pattern of marriage was usually explained in a functional manner, i.e. either by assuming that arbitrary

sentiments are associated with each category of kinship on the basis of extension from nuclear relationships or as arising from clan solidarity (Radcliffe-Brown 1931). In contrast, Levi-Strauss (1969) was able to show that consanguinal or elementary forms of marriage are best explained as a consequence of the distribution of kinship produced by an underlying, continued exchange relationship. Within the functional framework, it is very difficult to give an adequate explanation for certain forms of marriage that are readily analyzed by structural methods. For instance, Radcliffe-Brown was able to provide no way of distinguishing theoretically between a simple moeity system, and a section system of the Kariera type. Although the latter contains four rather than two marriage classes, the operation of the dual descent systems and the form of the prescriptive marriage rules results in bilateral cross-cousin marriage as in a moeity organization. Taking consanguinity as a theoretical basis, Radcliffe-Brown was forced to conclude that the two systems were in fact equivalent (Levi-Strauss 1969). However, Levi-Strauss showed that the logical distinction between the systems results in significantly different forms of integration between exchanging groups. Furthermore, as pointed out by Friedman (1974), when Radcliffe-Brown's methods are applied to more complex section systems they result in such untenable theories as the reduction of the eight section Aranda system to preferential MoMoBrDaDa marriage. The ascendancy of structural theory rests largely on the successful explanation of such empirical patterns of consanguinal marriage in terms of the formal properties of the exchange systems.

Complex structures contrast with elementary systems in that they possess bilateral descent, and only negative marriage proscriptions arising from an incest prohibition. In an elementary system, alliance is mechanical in the sense that the exchange rules uniquely determine a

4

single category of marriage choice; in complex systems, alliance has a statistical nature since the range of marriage choice is very wide, excluding only a few, closely related individuals. Many societies stand midway between these poles of exchange in that they possess unilineal descent, but still have only negative marriage rules. Since these negative rules typically exclude a number of closely related descent lines or clans from the range of marriage possibilities, such societies, while exhibiting a statistical degree of exchange, do not allow the full range of choice found in complex structures. Societies having this mediating form of exchange are said to be of the Crow-Omaha type.

Crow-Omaha systems play a central role in Levi-Strauss' program of exchange analysis:

We must concede [a strategic position] to Crow-Omaha systems in the theory of kinship and marriage. For they provide the hinge which articulates elementary structures....with complex structures....In fact the Crow-Omaha systems still belong to the elementary structures from the point of view of the marriage prohibitions they frame in sociological terms, but they already belong to the complex structures from the point of view of the probabilist alliance network they produce. (Levi-Strauss 1966:19)

The analysis of Crow-Omaha exchange, with its partial statistical nature, would provide the key necessary to unlock complex structures. Unfortunately, even the degree of statistical choice allowed in Crow-Omaha systems introduces so many complexities that Levi-Strauss has abandoned his program.

To see why he did so, it will be useful to place the above considerations into a more formal context. A society can, in principle, be divided into a number of marriage classes, all individuals in each class having the same set of marriage prescriptions or prohibitions. A marriage type is then defined by the union of any two classes between which a

marriage is theoretically possible. In an elementary system, the ideal marriage type assigned to each individual is uniquely determined by that of his or her parents (differentiation within a class is limited at most to sex). This determination is expressed as a positive marriage rule. Although demographic variation limits the number of ideal marriage types that can actually be realized (cf. Kunstadtler et al 1963), thus transforming any prescriptive model into a preferential system, this does not create a theoretical difficulty since only one marriage is necessary to renew an alliance in each generation (Friedman 1974). For this reason, a mechanical model, in which all marriages are assumed to follow the ideal pattern, provides an adequate description of the properties of any system of elementary exchange (Levi-Strauss 1966,1969).

Unlike systems of elementary exchange, those of the Crow-Omaha form do not provide a unique specification of the marriage type of each individual. Navajo marriage rules, which are used to illustrate the analysis of Crow-Omaha exchange in subsequent chapters, provide a concrete example of this situation. The Navajo have dispersed, matrilineal clans loosely organized into eight or nine unnamed clan groups; nearly fifty clans were known to exist in the 1930's (Aberle 1961). Although informants disagree on the assignment of clans to particular groups, there is a general agreement on the nature of the reported marriage rules.<sup>2</sup> Marriage is said to be prohibited with members of ego's Mo's and Fa's clan group and between individuals whose Fa's are of the same clan group. Beyond these restrictions, marriage is apparently statistically determined, although some ethnographers have reported a preference from marriage into either the paternal or maternal grandfather's clan (Aberle 1961). This possible preference, discussed in greater detail in Chapter 2, will be ignored for the moment.

A Crow-Omaha system of exchange such as that of the Navajo can be theoretically defined in the following way. Marriage classes can be formed by attaching to each individual a vector listing all clans related within the prohibited degree of kinship. Each class then consists of all individuals having identical marriage vectors, and hence equivalent marriage prohibitions. The exchange rules allow a marriage only when the vector entries of both partners are completely distinct, a condition which also implies that no equivalences can occur in an individual vector since the entries form a subset of those from two parental vectors.

In the Navajo case the marriage vector has two entries, one for the mother's clan or clan group, and the other for the father's clan or group. On the basis of ethnographic reports showing the existence of nine clan groups, it is possible to calculate the number of allowable marriage types. This is equivalent to the number of vector pairs without similarities in the entries, which I calculate to be 3,024. Since relationships between clans will generally be more important than those between clan groups, and since each group contains more than one clan, this figure actually underestimates the true number of marriage types. If, as I will argue later, the effects of clan groups can be ignored and the Navajo are assumed to have fifty clans then the number of marriage types rises to 5,527,200. Taking either figure, the magnitude of the problem is already apparent. As discussed above, the diversity of potential alliance can be transformed into actual marriages only on the basis of probability considerations. Since the Navajo have a minimum set of prohibitions, the number of marriage types in other Crow-Omaha societies, such as Hopi, having more extensive rules, will be larger. As reported by Levi-Strauss (1969) the Hopi have thirteen phratries and prohibit marriage into three

of these: the Mo's, Fa's and MoFa's. On this basis the possible number of marriage types can be calculated to be 1,235,520, which is considerably higher than the equivalent clan group figure for the Navajo. It can thus be concluded that a statistical model is always necessary in the consideration of Crow-Omaha exchange.

Levi-Strauss has established two major analytic difficulties associated with such a statistical model. Firstly:

In order to commence operations, an initial state would have to be determined. The danger then would be that of being trapped in a vicious circle, because the state of possible or prohibited marriages is constantly determined by marriages which have occurred in preceding generations. The only solution to the problem of determining an initial state which does not violate one of the rules would be a regression to infinity, unless one were to assume that, despite its aleatory appearance, the Crow-Omaha system returns on itself periodically in such a way that, taking any initial state whatsoever, after a few generations, a structure of a certain type must necessarily emerge. (Levi-Strauss 1969:xli).

But even if it was found possible to initialize the model a second difficulty would present itself:

Almost all societies with a Crow-Omaha system were small in population. The most studied of these, the American examples, had fewer than 5,000 persons. Consequently, the types of marriage which were actually practiced in each generation could represent only an absurdly low proportion of the possible types. The result is that in a Crow-Omaha system the marriage types are not realized only at random, given the prohibited lineages. A factor of chance to the second power intervenes and chooses, from among all potential marriage types, the small number which will become actual, and which will define, for the generations born of them, another range of possible choices, which, for the most part, are fated to remain merely potential in their turn. (Levi-Strauss 1969:xli).

Both these problems are associated with demographic factors. In elementary systems it is possible to separate the prescriptive or mechanical model from the demographic history of the population; in the case of



Crow-Omaha exchange, the model is itself both historical and demographic. Levi-Strauss holds that this difference presents a nearly insurmountable problem for structural analysis, and hence he has abandoned the program to provide a universally applicable theory of kinship and marriage.

But this conclusion derives from an incorrect assumption about the type of demographic model which is suitable to describe Crow-Omaha exchange, and it is this topic which I will now take up to advance the program. Specifically, the fundamental error made by Levi-Strauss and other anthropologists is to assume an equilibrium situation in which each exchange unit, or marriage class, is represented by one opposite-sex sibling pair in each generation. This is appropriate for a system of elementary exchange, where the marriage type of each individual is uniquely determined, or differs at most with regard to sex. But this is not the case with Crow-Omaha exchange, where marriage is determined probabilistically, and hence influenced by variation in family or clan size.

Levi-Strauss (1966) justifies the use of equilibrium models by distinguishing between "paleolithic" and "neolithic" demographic conditions. The term "paleolithic" refers to a stable demographic situation in a constant and sexually balanced population in which stochastic variation has little effect on exchange. In contrast, under "neolithic" conditions of rapid demographic change, stochastic variation may have a significant influence on exchange. In the case of elementary exchange, however, such an influence is external to the model, and the "paleolithic" analysis has theoretical priority. In fact, the effects of demographic variation can only be understood once the equilibrium properties of the system are known. However, this argument does not apply to Crow-Omaha exchange where demographic factors are inherent in the model.

Since the problems that Levi-Strauss has identified are related to the finite size of the population in a Crow-Omaha society, it is clear that demographic variation must be accounted for in an analytic model. If the population was sufficiently large that such variation could be safely ignored, then the analytic problems disappear. Conversely, if the Crow-Omaha problem is apparent then exchange must be affected by demographic variation. There is a trivial sense in which demography can be said to limit the structure of Crow-Omaha exchange, for it is obvious that the number of clans can be no greater than the total population size. A Crow-Omaha structure with this maximum number of clans has statistical properties equivalent to a complex structure, but it is important to note that the existence of unilineal descent will cause the build-up of larger marriage classes over time. More significantly, as the number of clans is increased within a population having a fixed total size, the number of individuals in a descent category decreases, allowing stochastic demographic effects to have a greater influence on the size and composition of each clan.

In Chapter 3, I will show how a non-equilibrium model which takes account of these facts can provide a resolution to the problems posed by Levi-Strauss. At heart, the solution is based on a complete reversal of Levi-Strauss' method of analysis, beginning not with a fixed number of clans in an equilibrium situation and seeing demography as the problem to be solved, but with an existing demography and Crow-Omaha ideology and, so to speak, solving for the associated clan organization. Using this approach, it can be shown that in a finite population a Crow-Omaha system operates to cause the convergence of the clan organization to a "minimal structure of exchange" determined by the marriage rules. This convergence occurs irrespective of the assumed initial clan composition or precise

demographic history of the population. In other words, regardless of specific considerations, in a Crow-Omaha society, given a finite population size and stochastic variation (i.e. a "factor of chance of the second power" as referred to by Levi-Strauss above), the operation of the exchange system will result in a variable distribution of clan sizes, and it is this variation which will inevitably cause the convergence to the minimal structure of exchange.

The minimal structure is determined by the nature of the exchange rules. Since, under Crow-Omaha rules, a marriage can be formed only when the marriage vectors of the potential partners are completely distinct, a minimal number of clans is necessary for the operation of the system. In the Navajo case, where the marriage vector has two entries, the minimal structure consists of four clans each considered to be in a separate group. In general, the minimal number may be greater with more extensive rules, but in no case can it fall below four.

The potential appearance of the minimal structure has also been recognized by Levi-Strauss, who minimized its importance:

Since as a general rule, marriage is allowed with all clans not subject to a formal prohibition, the Aranda type structure, towards which every Crow-Omaha system would tend if the number of clans were approaching four, will remain submerged, as it were, beneath a flood of contingent incidents. It will never crystallize into a stable form. Here and there it will show through in a fluid and undifferentiated environment, but only as a faint and fleeting shadow. (Levi-Strauss 1969:xxxviii).

Consideration of the Navajo ethnographic data will show that, for this society at least, Levi-Strauss' viewpoint is incorrect. In fact, the minimal exchange structure appears as a dominant statistical pattern. In the Navajo case, where a large overall population exists, the convergence of the exchange system is significant at the community level. The history

of each Navajo community can be traced back to a small founding population which restricted the local number of clans and emphasized the stochastic properties of the exchange system.

The minimal structure has a mechanical nature which makes it tempting to assimilate the analysis of Crow-Omaha systems to that of elementary exchange. But this would overlook a very significant difference which exists at the level of the operation of the systems. I have already mentioned that demographic effects can limit the number of ideal marriages within an elementary system. In such circumstances new marriages are formed with previously unrelated lines, having the effect of expanding the alliance pattern. These marriages are not so much violations of a positive rule as they are explorations of the potentialities of the system. Each new alliance creates a distribution of kinship which extends the possibility of further marriage when converted into a continued pattern by the application of the positive exchange rule.

A demographic problem of a totally different nature is created by the convergence of Crow-Omaha exchange. This convergence results in the exclusion of an ever increasing proportion of the population from the possibility of marriage with an individual ego. In the face of further demographic variation, the problem becomes one of creating marriage partners from within the set of individuals who are formally excluded from marriage by the exchange rules. While it is possible to simply violate the rules in this case, this strategy does not have the effect of increasing the range of future marriage possibilities as in the expansion of the alliance pattern in elementary exchange. Instead it can only lead to further and more extensive violations of the rule system. While technically a similar problem could occur within a society having a clan system

and elementary exchange, this would only be apparent when the population size was very small. In contrast, the problem will exist in Crow-Omaha systems even when the population is larger, resulting in the necessity of a social solution such as immigration or clan fissioning, two well-known features of clan societies.

To see intuitively why this difference exists, consider two societies of the same population size, one exchanging under the Navajo Crow-Omaha rules, the other having elementary exchange with reciprocal alliance. To examine only the effect of the negative or exogamy rules of these societies, attention can be limited to the minimal number of clans necessary for the operation of exchange: four clans in the case of Crow-Omaha exchange, two for the elementary system. In the sex-ratio is assumed to be  $1/2$ , and each clan to have an equal number of members of each sex, then the relative effects of the marriage prohibitions in the two cases can be determined as follows. Under reciprocal exchange,  $1/2$  the population is excluded from marriage by the rule of exogamy, and  $1/2$  by sex constraints, leaving  $1/4$  of the population eligible for marriage with a specified ego. In the Crow-Omaha case, a marriage can be formed only if the marriage vectors of the two partners are completely distinct. Under the equilibrium assumptions given above, this excludes  $3/4$  of the populations. Accounting for sex-ratio leaves  $1/8$  of the population eligible for marriage with ego. The differences between these two figures leads to the intuitive expectation that demographic variation will have a greater effect in the Crow-Omaha case since the number of eligible marriage partners is smaller, and hence more susceptible to stochastic effects. This intuition is confirmed by simulation studies in Chapter 3. With further extensions of the Crow-Omaha rules, the population restrictions, and hence the magnitude of the stochastic forces, are even greater. This establishes

a qualitative difference between demographic effects under Crow-Omaha and elementary exchange.

The convergence of Crow-Omaha exchange introduces a new social problem: the necessity of creating marriage partners in a situation where demographic constraints are severely limiting exchange possibilities. For this reason, factors that counteract the tendency towards exchange convergence have a major social significance. There is no evidence of clan fissioning in Navajo society, but a relationship between inter-community migration and marriage has been shown ethnographically. The explanation of this relationship in terms of the constraints of the exchange system will provide a strong justification for the demographic viewpoint adopted here.

## 2. Conclusion

The model of Crow-Omaha exchange proposed by Levi-Strauss leads to problems of a demographic nature that he is unable to solve. By reversing his argument, it is possible to delimit a theoretical range of exchange structures which can exist within a finite population under one set of marriage rules. At one extreme of this range is a structure in which each individual is assigned to a separate clan. At the other extreme is the minimal exchange structure defined by the rules of marriage prohibition. Stochastic demographic effects provide a dynamic which links the two extremes through the tendency of convergence of any initial system towards the minimal structure. This dynamic will be investigated in the context of Navajo social organization in the following chapters.

Notes to Chapter 1

1. I will use the term "Crow-Omaha" to refer only to the system of exchange. Levi-Strauss does not always distinguish between Crow-Omaha kinship and exchange, but whenever interpreting his quotations I will assume his statements relate to the exchange structure even when he explicitly refers to kinship. The necessity of the distinction is demonstrated by Barnes (1977) who gives examples of societies with Crow-Omaha exchange but without this system of kinship terminology, and also of the converse form. The Navajo are an example since they are usually described as having Iroquoian kinship. In any case it seems clear that when Levi-Strauss mentions Crow-Omaha kinship, he is actually referring to a complex in which the exchange form is dominant, and the kinship terminology secondary. In general, Crow-Omaha societies are typified by classical unilineal clan organization with proscriptive rules of marriage.

2. The prohibition between individuals whose Fa's are of the same clan has been reported by recent ethnographers, e.g. Aberle (1961), Shepardson and Hammond (1970), Witherspoon (1975). In her early, and now classic, study Reichard (1928) reported a preference for marriage into the Fa's clan. This has universally been regarded as an error in the light of the explicit prohibition found later.

3. Levi-Strauss (1966, 1969) provides figures of a similar magnitude for various numbers of clans and marriage rules. However, I have not been able to re-derive his results. My calculations give the number of distinct vector pairs based on sampling without replacement from the total pool of clans or clan groups.

## CHAPTER 2

The theoretical aspects of Crow-Omaha exchange discussed above are investigated within the context of Navajo ethnography in subsequent chapters. I have already described the Navajo system of exchange as being characterized by geographically dispersed matrilineal clans, and negative marriage rules. The clans are not corporate descent groups, functioning primarily in the regulation of marriage and hospitality. This makes Navajo society ideal for an initial analysis, since it avoids complications in the exchange structure which might occur due to ranking of clans, or other hierarchial factors. Ethnographic data on the clan composition of Navajo communities is reviewed below.

### 1. Navajo Communities

The history of present-day Navajo communities can be traced to the settlement of the reservation in 1868. Prior to this date, the Navajo occupied a wide area of what is now Arizona and New Mexico, and had an expanding economy based on sheep-herding and subsistence farming. During the 1800's, Navajo territorial and population expansion resulted in conflict with newly arriving American settlers, eventually resulting in the infamous "pacification" program directed by Kit Carson. In 1863, Carson led American troops into Navajo territory with the deliberate intent of destroying all crops and herds. The Navajo were ordered to surrender at Fort Sumner, New Mexico, nearly two hundred miles away, or face starvation. Although some isolated groups were able to resist by retreating to remote canyon areas, by 1864 over 8,000 of the Navajo people had made the long trek through the desert to internment. After four years at Fort Sumner, where the army tried unsuccessfully to convert their economy to subsistence



farming in order to leave range land free for American settlers, the Navajo were allowed to return to a newly created reservation, a fraction of the size of their original homeland. Further historical information regarding this period can be found in Terrell (1970).

The Navajo population has expanded from approximately 10,000 in 1868 to over 130,000 today (Morgan 1973a). This rapid growth, combined with government policy on economic development, has led to many changes in Navajo society. In the early part of this century, the pressure from population growth was met by expansion of the reservation, but lobbying by Anglo ranchers and development interests led the U. S. Government to halt this approach to the problem by 1922 (Kelly 1968). Aberle (1966) has described how subsequent growth has been accommodated partially within the traditional economy, and partially by wage-labour employment. Despite the resulting economic changes, most ethnographers agree that the traditional system of kinship has remained a dominant social factor on the reservation (cf. Aberle 1961).

The pattern of resettlement after the period of internment resulted in the formation of local community groups reflecting prior band organization (Aberle 1961). Many group members had previous ties to the locality they settled, and a pre-existing network of kinship and alliance provided a basis for intra-community solidarity. The small size of each community, and the degree of intra-relationship also restricted the local number of clans. Although subsequent population expansion has resulted in much internal growth, the community remains as an important social unit:

Although increasing numbers of people from different local clan segments are coming into closer contact with each other, community boundaries have not disappeared. Moreover, clan marriage preferences appear to be maintaining clan localization despite the increasing range in choice of marriage partners. (Levy 1962:800).

The Navajo explicitly recognize membership within a community, and for this reason the community unit has been used to delimit social boundaries in most ethnographic studies.

The pattern of community settlement can be seen most clearly in Ramah, a locality to the southeast of the main reservation area. Kluckhohn (1956) has described the history of this community in great detail. He identifies the twenty-two year period between 1868 and 1890 as the founding era for Ramah. Virtually all subsequent immigration has occurred as a result of marriage into one of the families which entered the community during this period. The founding population was composed of approximately seventy individuals affiliated to eight different clans; two of these clans were subsequently minor in terms of size because all of the original female members were past child-bearing age. The remaining six clans are still the major clans in Ramah today.

The founding population was further divided into two outfits. The Navajo outfit is a bilateral, corporate kinship group which has been identified as the unit of production in most Navajo communities. By virtue of the bilateral formation, each outfit contained more than one clan, a fact which allowed the establishment of reciprocal alliance between the two groups despite the Crow-Omaha exchange rules. The relationship of clan organization and Crow-Omaha exchange to the empirical pattern of alliance between such groups is an important ethnographic topic, but is largely beyond the scope of this thesis. I will generally avoid this issue by referring only to the clan organization of the communities, ignoring any further structure determined by the outfits (see, however, Appendix III). An exception occurs in Table 3.1 which gives the clan affiliations and kinship relationships between the basic founding members of the Ramah community,

and also includes the outfit membership. This table confirms the initial restriction on clan membership discussed here. More complete genealogical information can be found in Kluckhohn (1956).

Although ethnographic accounts of the founding of other communities are not as complete as those from Ramah, the historical evidence that is available does confirm the generality of the pattern characterized by Ramah (cf. Shepardson and Hammond 1970; Witherspoon 1975). More detailed evidence is available showing the effect of the initial clan composition on future marriage exchanges within the various communities. The Ramah example is again characteristic. Spuhler and Kluckhohn (1953:301) note that as of 1948 "of individuals in the [Ramah] genealogies whose clan membership (or non-Navajo affiliation) is definitely ascertained, 77% are included within the four largest clans, 97% are included in the 6 largest" and that of "399 known marriages almost 88% are included within marriages of the 5 most numerous clans with each other and members of 4 additional clans." The six largest clans referred to are the founding clans discussed here.

The data on marriages and clan affiliations within the Ramah community reflects two important ethnographic patterns. Firstly, the community boundary obviously has an importance in restricting the range of marriage partners, a fact which is reflected in the continuation of the local pattern of clan affiliations established in the founding era. Secondly, as a result of this restriction, the local realization of marriage types as ascertained between 1868 and 1949 does not exhibit the statistical degree of marriage choice assumed in Levi-Strauss' model of Crow-Omaha exchange. Minor clans do appear in Ramah as a result of resettlement after a marriage between a member of a founding line and an individual outside of the community, but the pattern of exchange is dominated by marriage

between the largest clans.<sup>1</sup>

The pattern of marriage and clan affiliations observed in other communities are similar. Figures 2.1-2.7 summarize the relevant ethnographic data from seven communities, including Ramah for the purpose of comparison. A restriction on the number of clans and of marriage types is obvious in all localities. Clan designations are not given explicitly in these figures but can be reconstructed in the following way. Figures 2.1(a)-2.7(a), showing the size of clans ordered by magnitude at particular census dates, are formed from the data presented in Table 2.2. Clans are numbered in this table using a system introduced by Reichard (1928). From this data it can be seen that major clans vary from region to region, indicating that local significance is not solely the result of the absolute size of a clan.

Figures 2.1(b)-2.7(b) give the number of marriages in which each clan has participated over the known history of each community. The explicit marriage types from which these figures were constructed are given in Tables 4.2-4.7 in Chapter 4. The data indicates that a small number of clans have historically dominated the marriage patterns in each community. Interpreted in another way, it indicates the existence of a statistical pattern of marriage preference between the major clans in each of the localities.

There is a further body of evidence which confirms the results stated here. In the 1930's the American government surveyed clan affiliations in 52 regional "sub-units" of the Navajo reservation. Aberle (1961) has argued that these "sub-units" are approximations to associated communities, and has analyzed the survey data under this assumption:

For purposes of analysis, communities were grouped into three categories: those with 3 to 12 clans, those with 13 to 19 clans, and those with 20 to 28 clans. Clans were rank ordered in terms of size and each community was then examined to see how many of the largest clans were required to make up at least 50% of the population, and how many of the smaller clans made up the remainder. In communities with 3 to 12 clans, the median number of larger clans required to compose the population was 2, the median number of clans composing the remainder was 7. In communities with 13 to 19 clans, the median number of larger clans was 3, the median remainder was 14. In communities with 20 to 28 clans, the median number of larger clans was 4, the median remainder was 18. Although the range of clans was from 3 to 28 per community, and of the population from less than 50 to 12,000, in no case did it require more than 6 of the largest clans to make up 50% of the local community. In almost all cases, the remaining population consisted of a considerably larger number of clans. Thus the range of large LCE's (local clan elements) making up 50% of the community is narrow--from 2 to 6, and in most instances from 2 to 4, in spite of the great variation in size. Larger communities, however, contain many more relatively small clans than do small ones. (Aberle 1961:185).

Taken together with the data presented here, Aberle's analysis provides strong evidence for the local restriction of the exchange system.

There are two possible reasons for the persistence of local patterns of exchange and clan affiliations: (1) community endogamy and restricted immigration; or (2) a correlation between the clan affiliations of immigrants and those of prior community members. Information on Ramah, derived from Kluckhohn (1956), indicates the possibility that both factors play a role. From 1890 to 1950, a total of sixty-eight adults and four children immigrated to Ramah. Only three adults entered the community for reasons other than their marriage to a community member, and each of these individuals was accompanying an in-marrying relative. Almost all immigrants had kinship or clan ties to previous community members. A total of forty-five immigrants came from three communities--Two Wells, Thoreau, and Fort Wingate--where many members of the Ramah founding population had been

born or had once resided. Conversely, of thirty-one Ramah residents who left the area during this period, twenty-five married into one of these three communities. Kinship ties between immigrants and founding members of the population may, therefore, have been of significance in maintaining the restricted system of exchange, but at the same time the large majority of marriages were endogamous to the community (approximately 334 out of 399). Other communities exhibit a similar pattern. For instance, from Witherspoon's (1975:81) account of the Rough Rock community, it can be concluded that in over 61% of marriages in existence at the time of his fieldwork, both partners had been born in the community.<sup>2</sup>

Two comments should be made regarding the significance of the kinship ties involved in immigration. Firstly, since immigration without in-marriage appears to be virtually non-existent in the post-founding era of a community, kinship relationships cannot be the only determinant of community entry. Secondly, Navajo kinship extends beyond the maternal clan to other affiliated clans, and also to clans within the same group (see Chapter 4), and hence could not be solely responsible for the continued restriction of the exchange system. In Chapter 3 it will be shown that it is possible to explain the empirical distribution of clans within each community on the basis of exchange considerations alone, without taking account of kinship relations or of clan groups. However, the possible role of kinship as an ideology in the formation of inter-community alliance is discussed in Appendix IV. The justification for neglecting clan groups is given in Chapter 4 where it is shown that they have no effect on the statistical pattern of marriage exchange.

Two other ethnographic facts bearing on the question of statistical patterns of marriage preference are important. Reichard (1928) first reported a preference for marriage into either the maternal or paternal

grandfather's clan. The statistical validity of her observation has been confirmed by other ethnographers. For instance, Shepardson and Hammond report that of marriages ascertained in the Navajo Mountain community with the relevant clan affiliations known, 17.9% are into the paternal grandfather's clan, and 19.4% are into the maternal grandfather's clan.<sup>3</sup> The possibility that this is a recognized ideal form of marriage remains open (Aberle 1961; Witherspoon 1975). Ethnographers have also reported a tendency for siblings to marry into the same clan, a pattern which is clearly not independent of the preference for the grandparental clans. Zelditch (1959) has examined the sibling pattern statistically in the marriages at Ramah, and found it to be significant. However, his results must be viewed with caution in the light of a methodological flaw discussed briefly in Chapter 4.

## 2. Conclusion

Navajo communities play an important role in limiting the realization of the system of exchange. Ethnographic evidence indicates that the marriage patterns do not show the statistical degree of marriage choice assumed in Levi-Strauss' model of Crow-Omaha exchange. The empirical distribution of clans within communities will be discussed theoretically in Chapter 3.

## Notes to Chapter 2

1. It should also be noted that the continuance of the initial pattern of clan affiliations was reinforced by the fact that almost all immigrants into Ramah have been male, and thus have failed to establish their clans in the community. Lathrop and Morgan (unpublished) have made a statistical analysis of Reichard's (1928) census data from five communities to determine if an association between the sex-ratio and the size of a clan could be observed outside of Ramah. The results were negative, and as a result the Ramah immigration data has not been used to explain the distribution of major and minor clans occurring in other areas.

2. This may actually underestimate the number of endogamous marriages. Witherspoon (1975) indicates that most of the marriages not included in this figure are into groups located very close to Rough Rock. It is possible that these groups are actually part of a wider community formed by population expansion.

3. Of a total of 644 marriages, 366 cases have the MoFa's clan known and 322 cases with the FaFa's clan known.



TABLE 2.1 THE BASIC ADULT FOUNDING POPULATION AT RAMAH

<u>Name</u>	<u>Relationship of Inclusion</u>	<u>Mo's Clan</u>	<u>Fa's Clan</u>
1. Cojo	Trader previously married to Cojo's Mo and MoSi.	Todikoji	Tabaza
2. Bah	Wife of the above.	Todich'ii	Acihi
3. Tall Woman	Sister of the above, also wife of Cojo.	Todich'ii	Acihi
4. Trader	MoBr of Many Beads.	Kiiya'aanii	?
5. Short Woman	Wife of Trader.	Tsenhabilni	?
6. War Comes Over the Hill	Da of the above, also wife of Trader.	Tsenhabilni	Kiiya'aanii
7. Salao	So of 5's Si and 4's Br.	Tsenhabilni	Kiiya'aanii
8. Going to War	Wife of above, Da of Cojo's Fa and MoSi.	Todikoji	Tabaza
9. No Hat	// cousin of Salao, maternal side.	Tsenhabilni	Tabaza
10. Alchindezba	Wife of the above, Da of 1's MoSi and of 4.	Todikoji	Kiiya'aanii
11. Jose Natan	Married 6 after her divorce from 4.	Toxedlini	Kiiya'aanii

(cont....)

Table 2.1 (cont.)

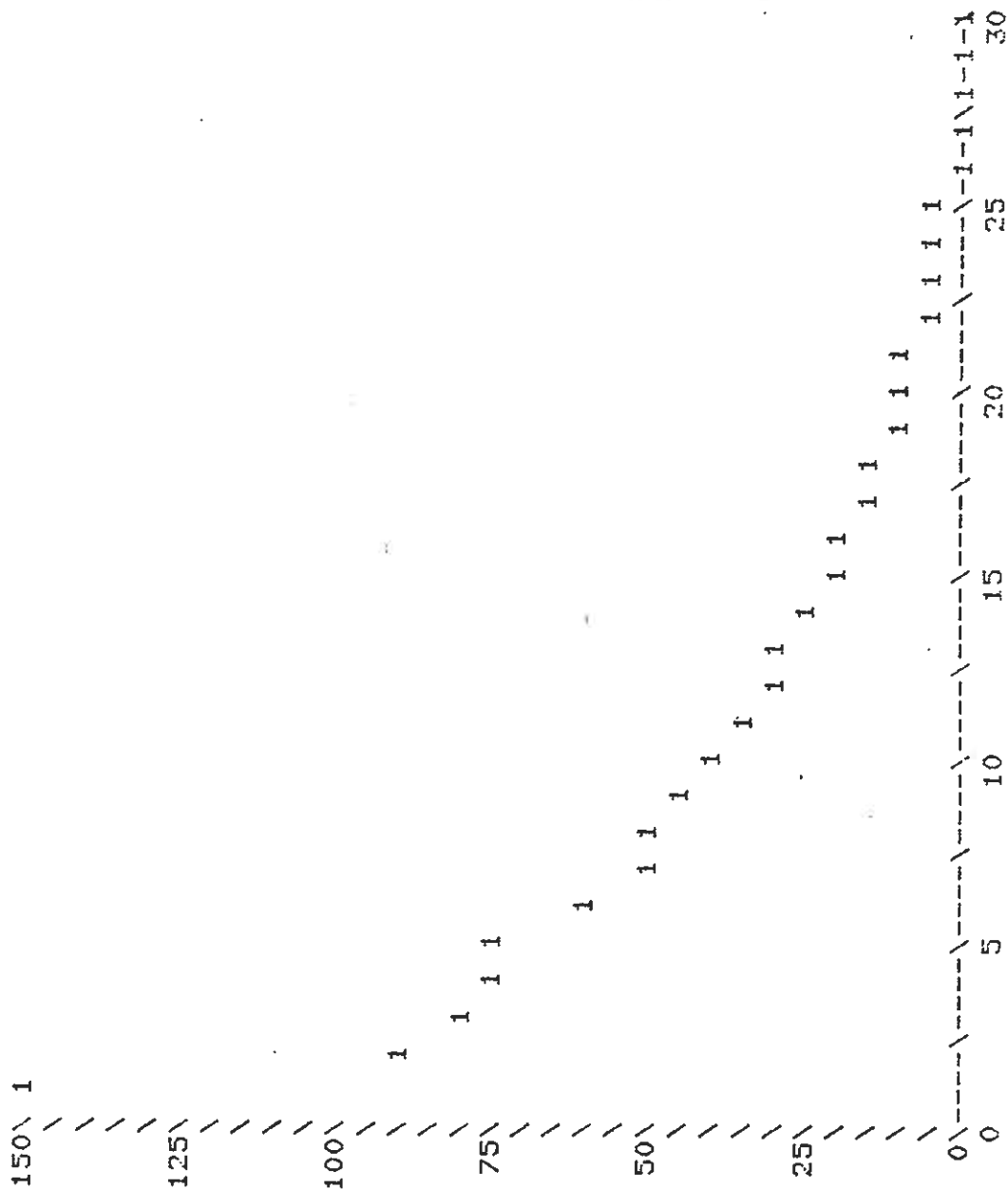
Many Beads Outfit

<u>Name</u>	<u>Relationship of Inclusion</u>	<u>Mo's Clan</u>	<u>Fa's Clan</u>
1. Many Beads		Kiiya'aanii	Hacl'ijni
2. Little Bah	Wife of above.	Haltsoi	Acihi
3. Grey Woman	Wife of 1, Da of above.	Haltsoi	Destci'ini
4. Loincloth	Br of Many Beads.	Kiiya'aanii	Hacl'ijni
5. ?	Wife of above, Si of 2.	Haltsoi	Asihi
6. Suckerman		Kiiya'aanii	?
7. ?	Wife of the above.	Taa'nazhani	?
8. Tall Loincloth	MoBr of Jake Bagan.	Kiiya'aanii	To'bajna'aj
9. Jake Bagan		Kiiya'aanii	Todich'ii
10. Joseba	Wife of the above.	Chiricahua Apache	
11. Amy	Si of above, also wife of 9.	Chiricahua Apache	
12. Red Moustache	Br of Little Bah.	Haltsoi	Acihi
13. Drives Horses	Wife of above.	No'daa	Kiiya'aanii
14. Beaver	Walapai brought up by Many Beads' Mo as a slave (Br of Many Beads)	Adopted in Kiiya'aanii*	

Source: Kluckhohn (1956) and Lamphere (1965)

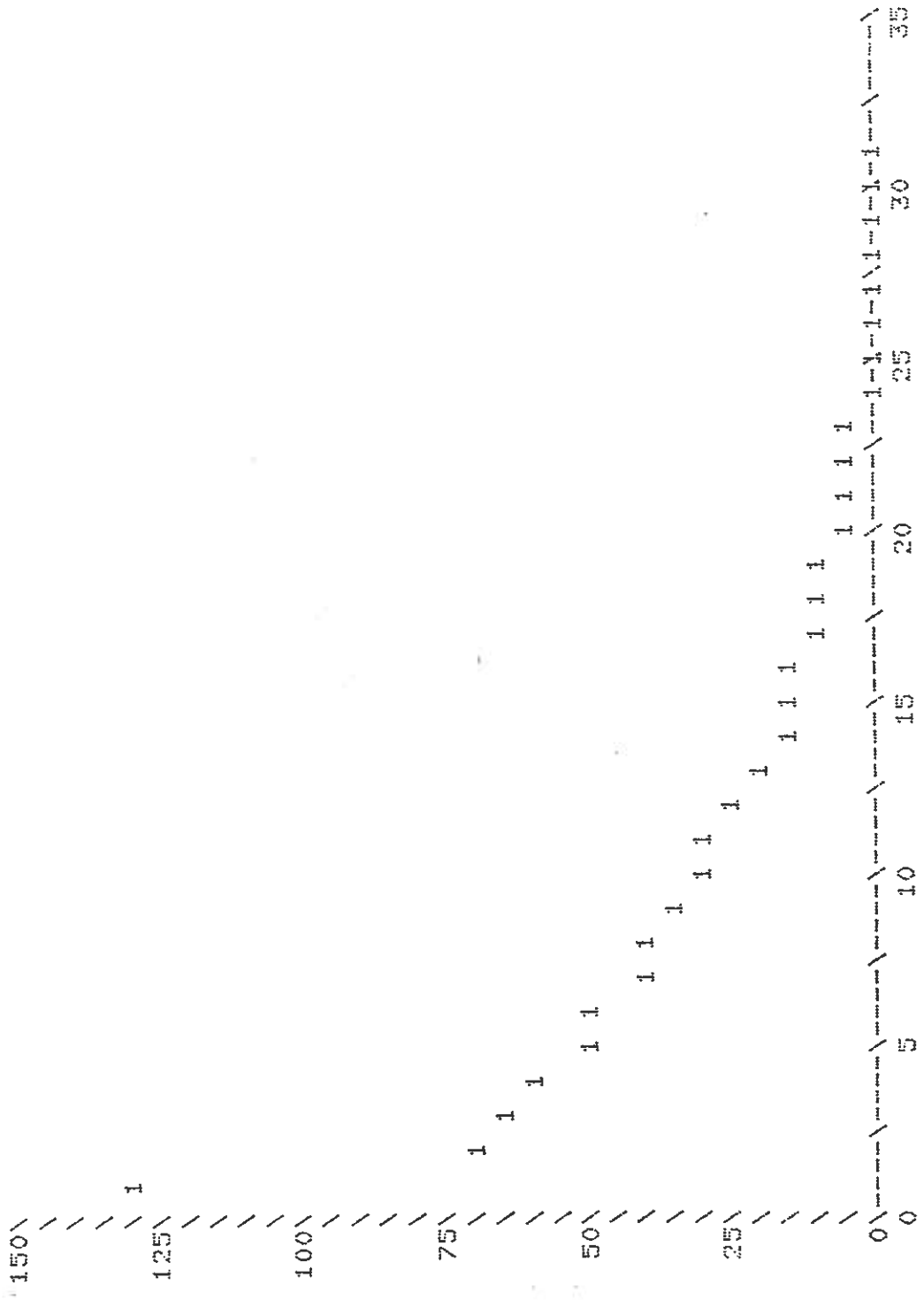
\* Beaver's clan is erroneously identified by Kluckhohn and Lamphere. The correction as given here is due to Morgan (unpublished).

FIG 2.1a CLEAN SIZE AT SHIPROCK: 1925



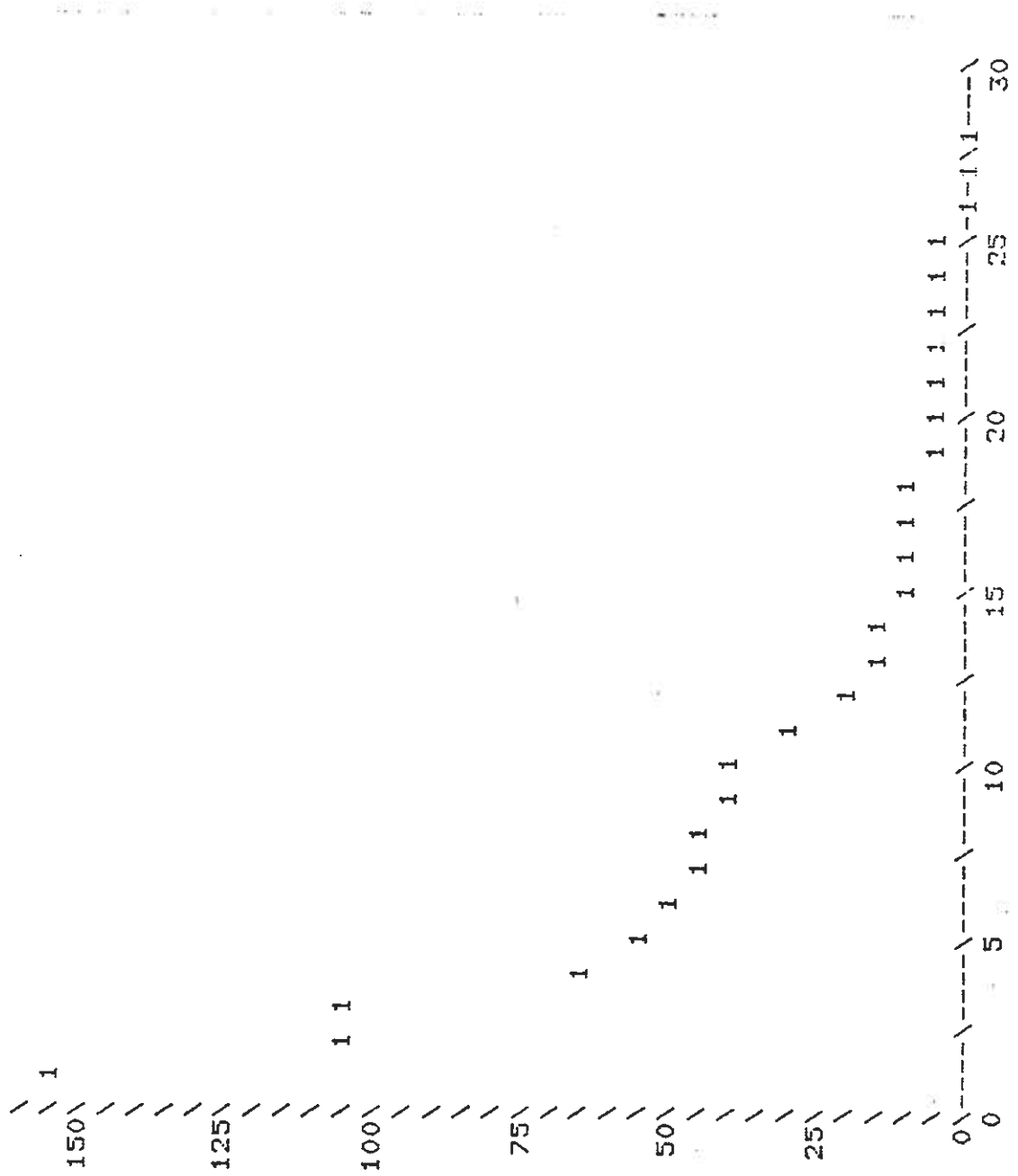
Source: Reichard (1928)

FIG 2.1b MARRIAGES AT SHIPROCK: 1925



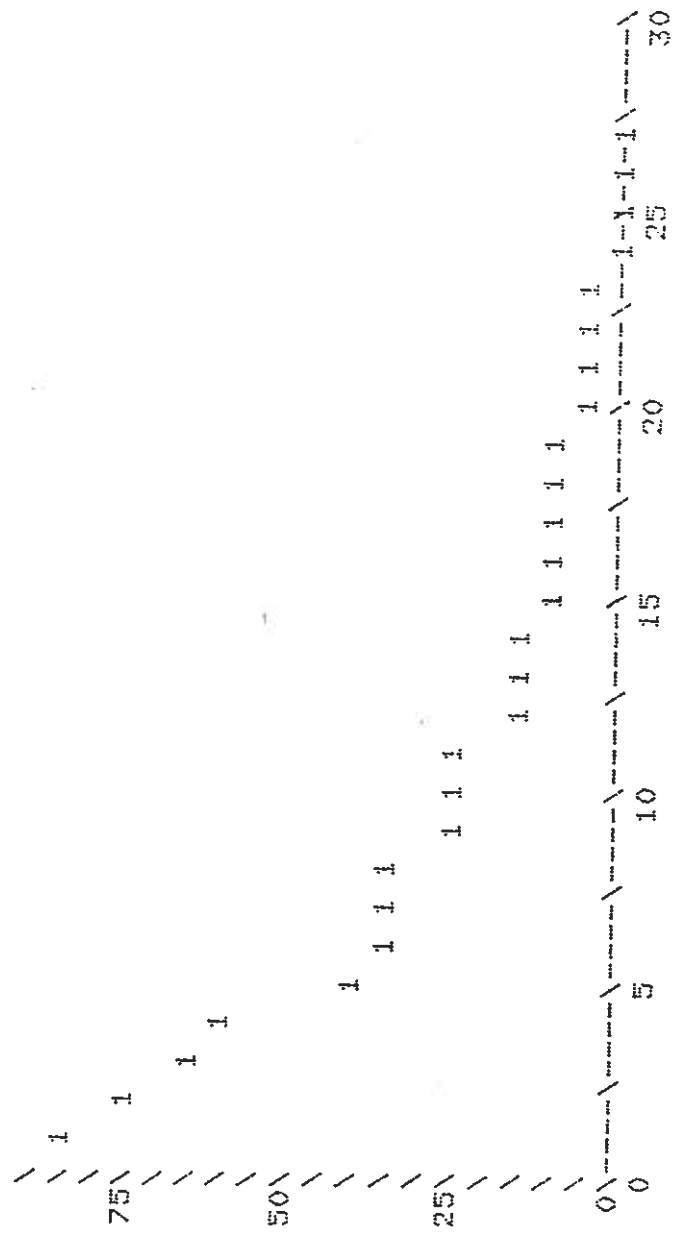
Source: Reichard (1928)

FIG 2.2a CLAN SIZE AT LUKACHUKAI: 1925



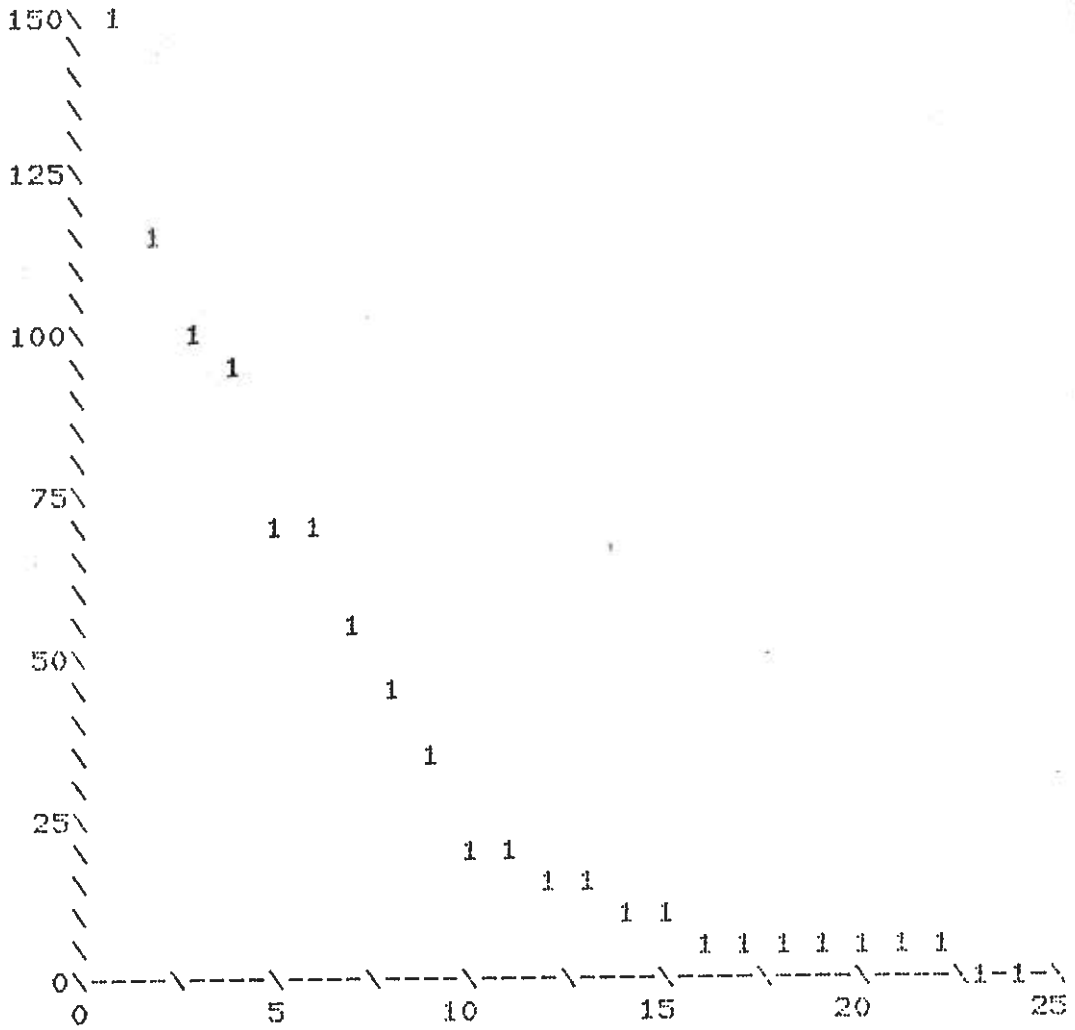
Source: Reichard (1928)

FIG 2.2b MARRIAGES AT LUKACHUKAI: 1925



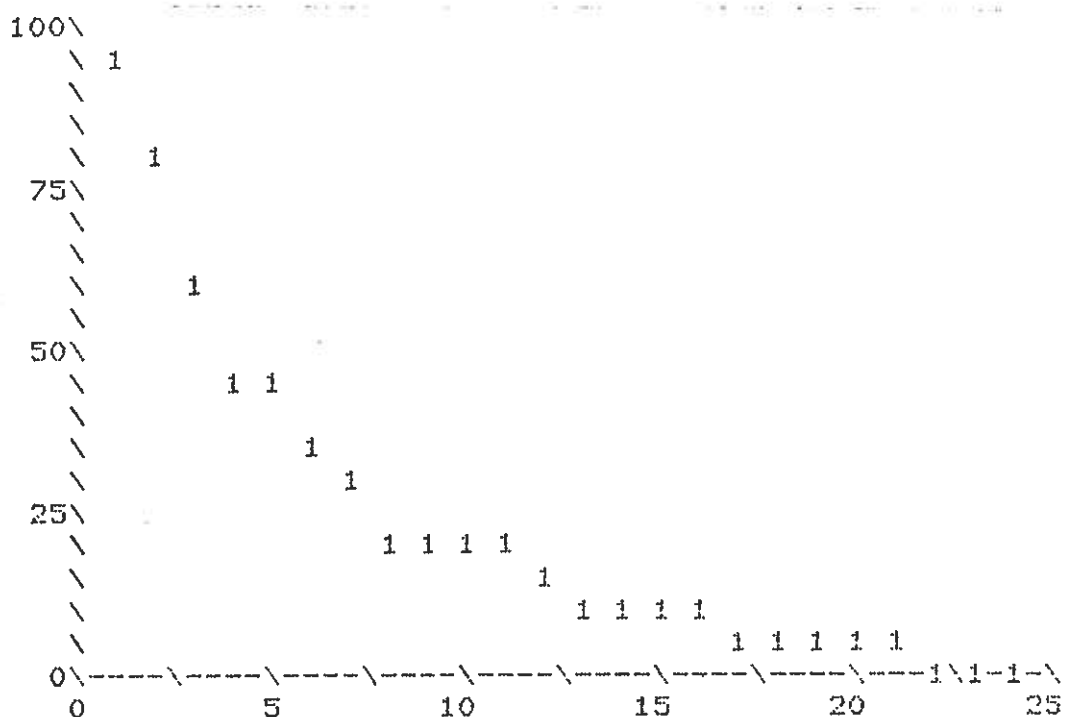
Source: Reichard (1928)

FIG 2.3a CLAN SIZES AT KEAM'S CANYON: 1925



Source: Reichard (1928)

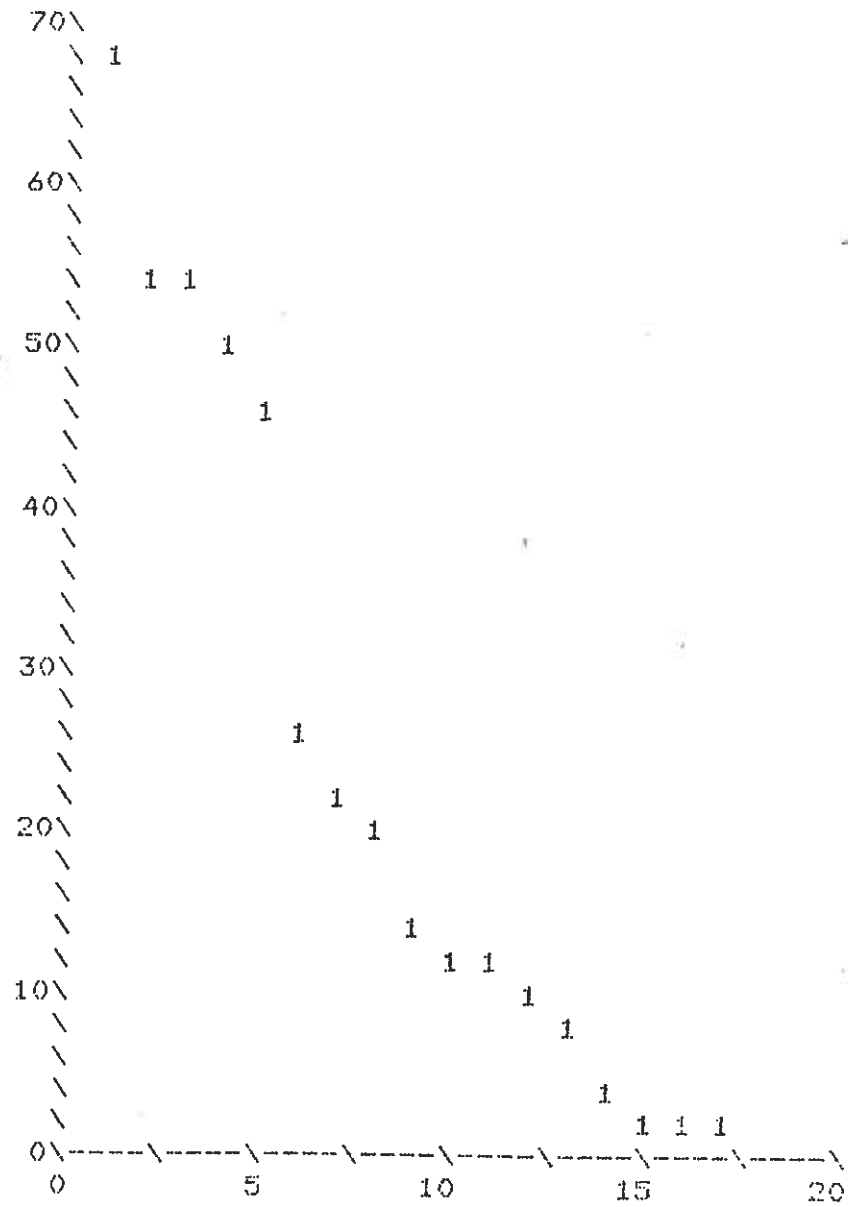
FIG 2.3b MARRIAGES AT KEAM'S CANYON: 1925



Course: Reichard (1928)

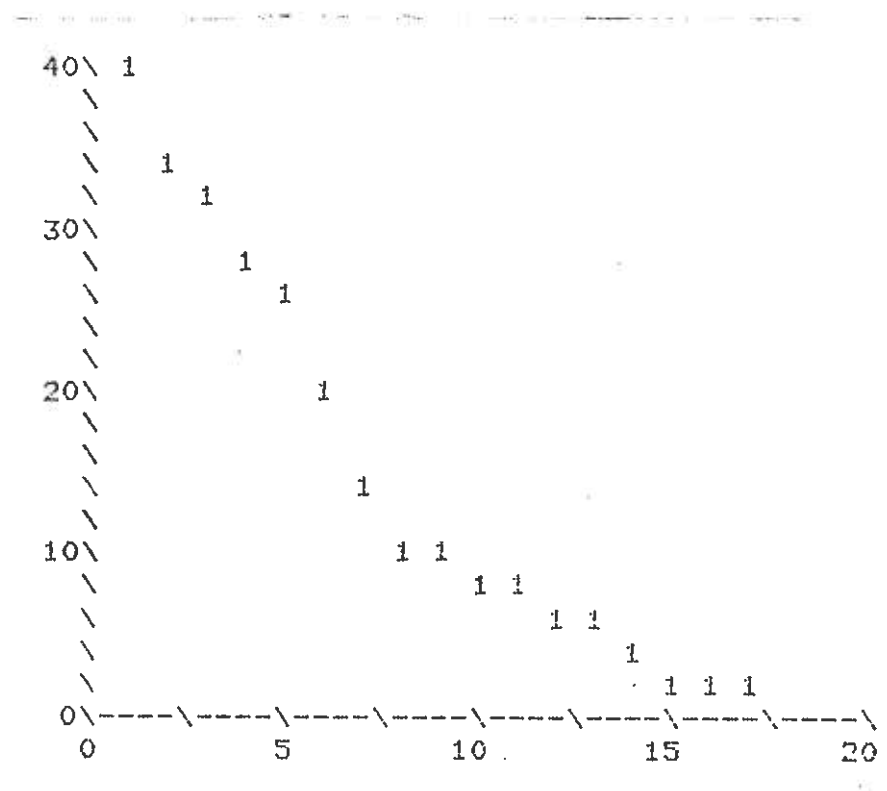


FIG 2.4a CLAN SIZES AT CANADO: 1925



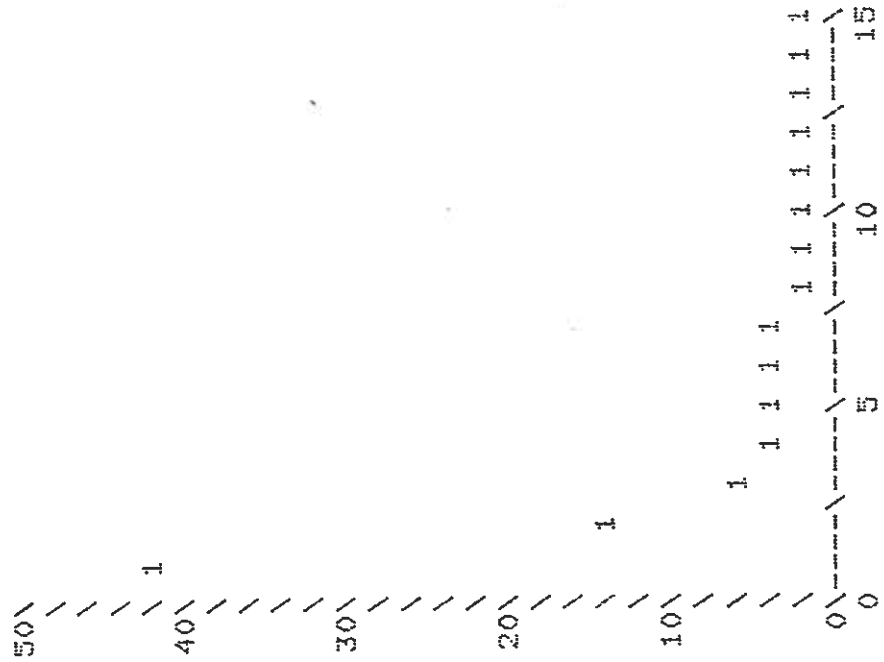
Source: Reichard (1928)

FIG 2.4b MARRIAGES AT GANADO: 1925



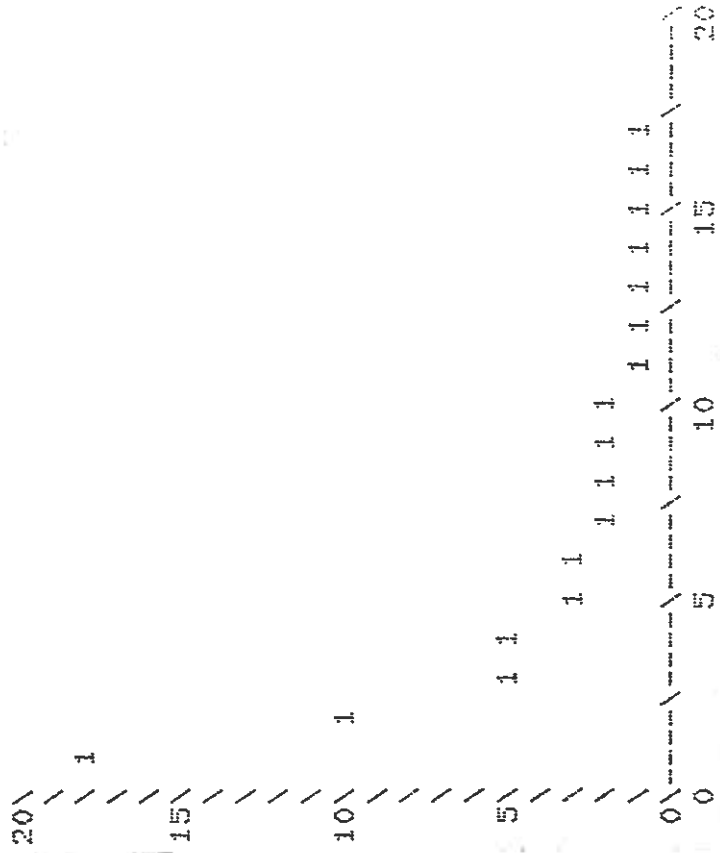
Source: Reichard (1928)

FIG 2.5a CLAN SIZE AT CHINLEE: 1925



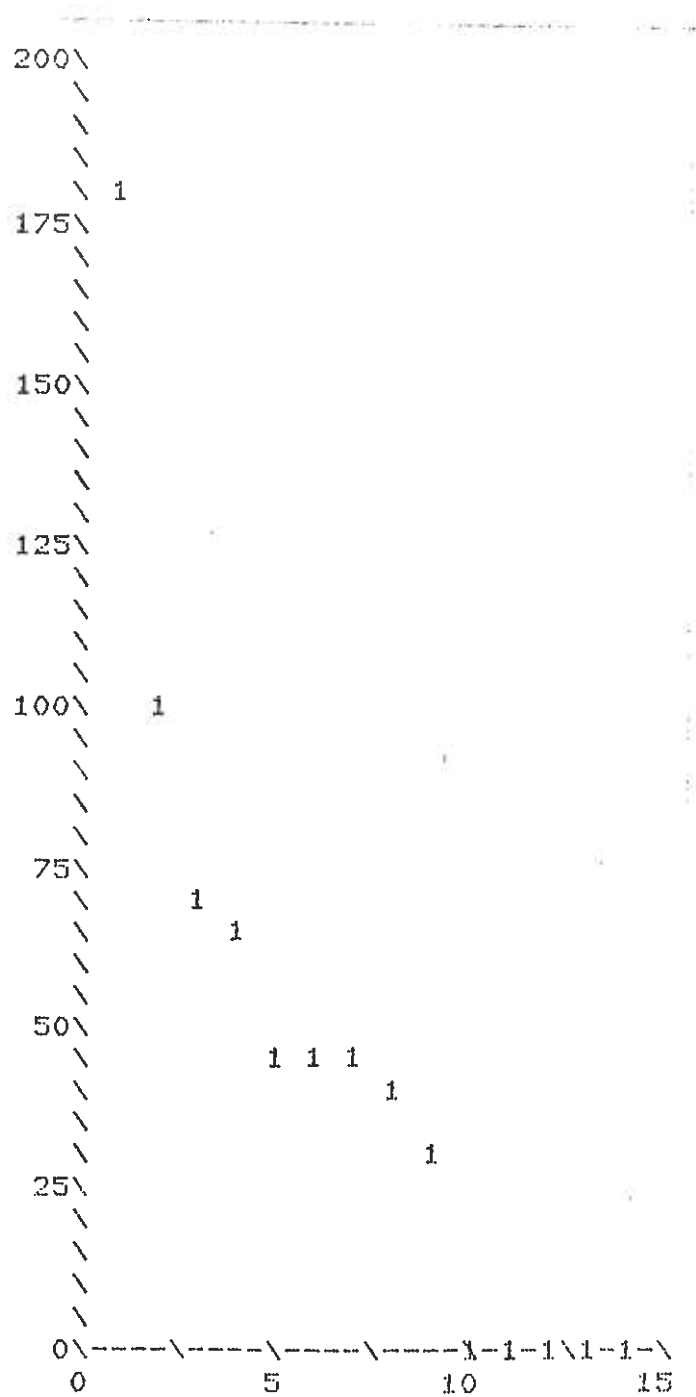
Source: Reichard (1928)

FIG 2.5b MARRIAGES AT CHINLEE: 1925



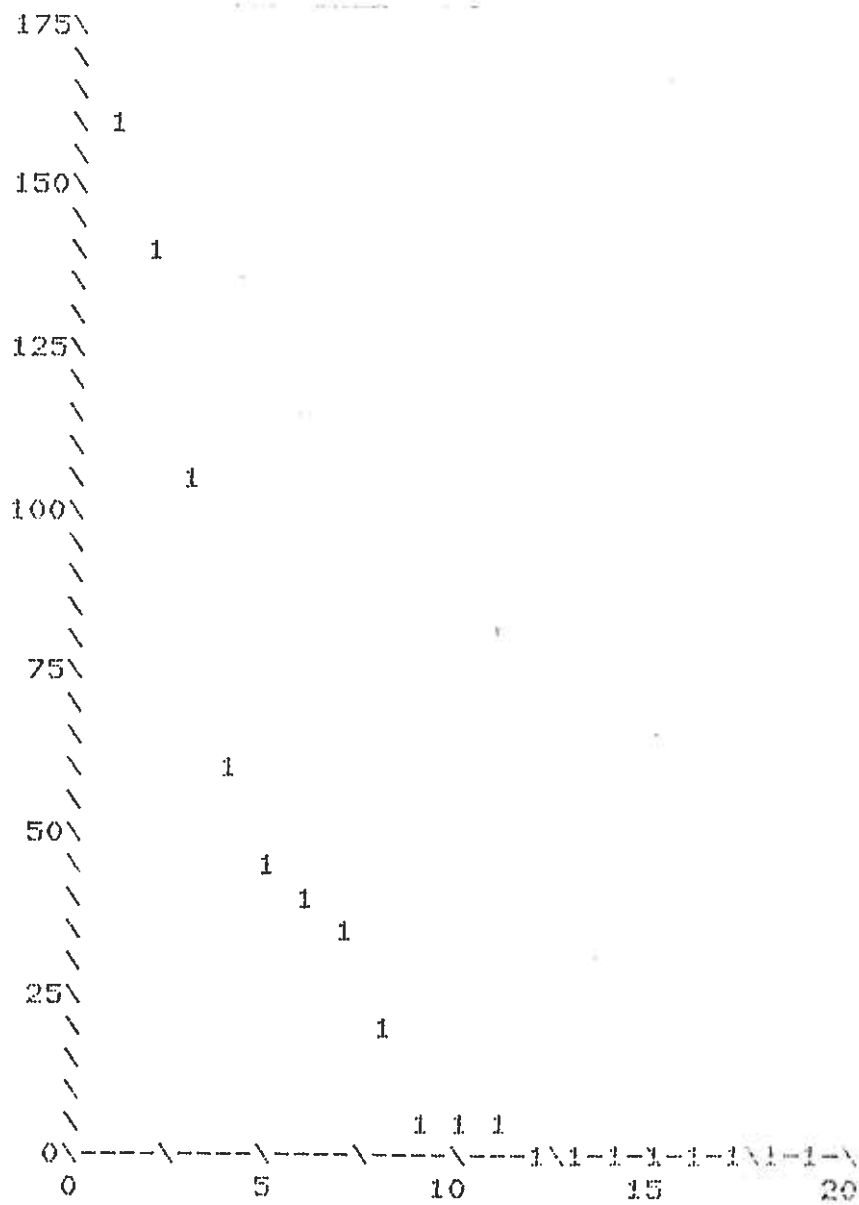
Source: Reichard (1928)

FIG 2.6a CLAN SIZE AT NAVAJO MOUNTAIN: 1961



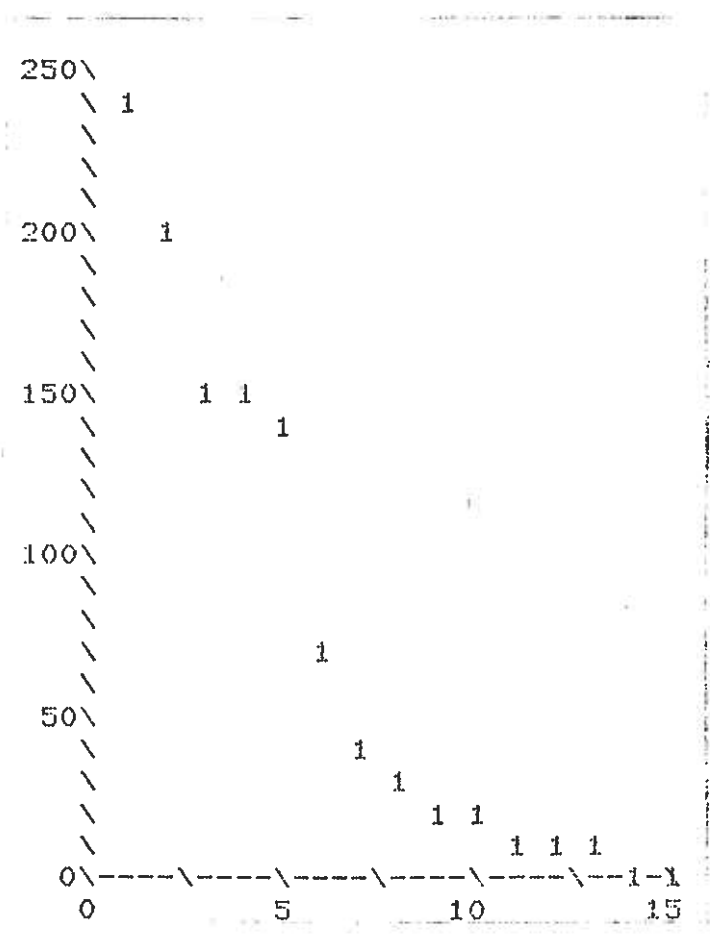
Source: Shepardson and Hammond(1970)

FIG 2.6b MARRIAGES AT NAVAJO MOUNTAIN: 1961



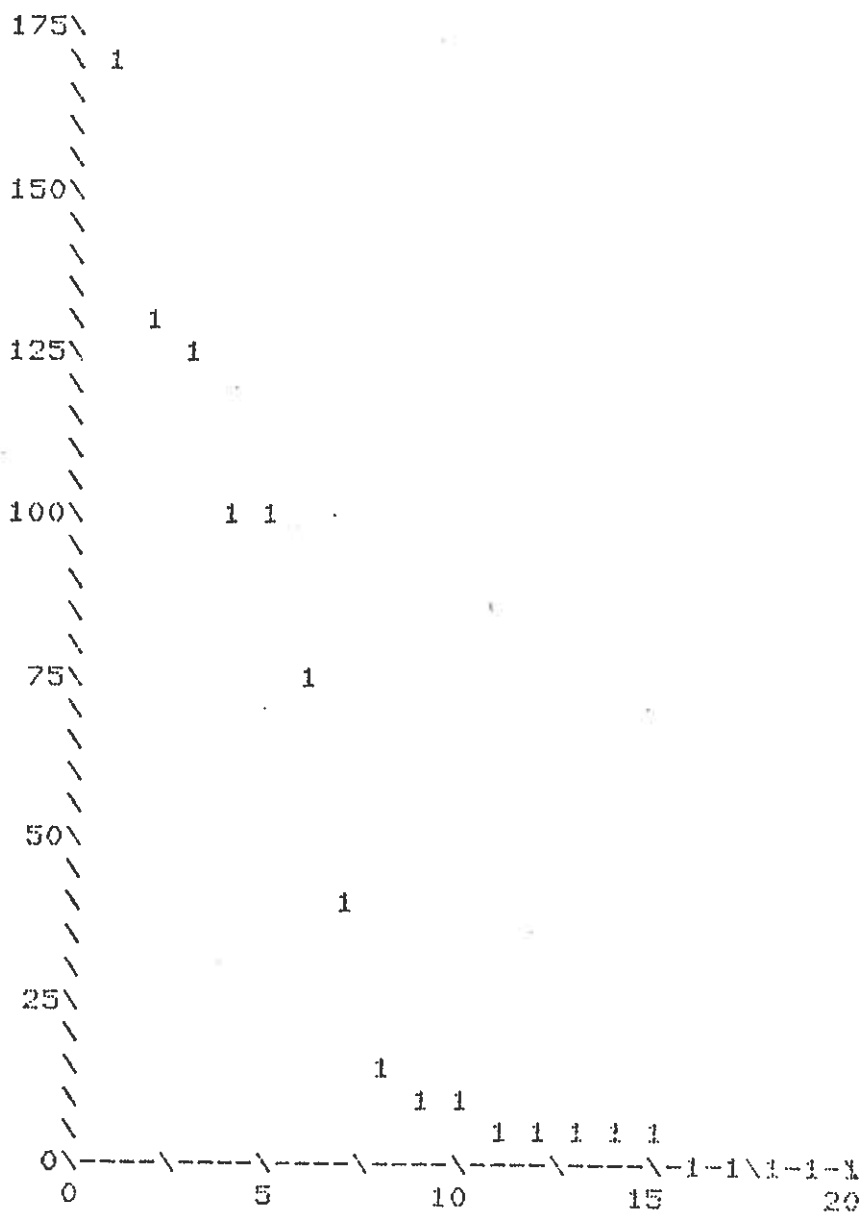
Source: Shepardson and Hammond (1970)

FIG 2.7a CLAN SIZE AT RAMAH: 1964



Source: field data of Dr. K. Morgan

FIG 2.7b MARRIAGES\* AT RAMAH: 1964



\* estimated from fertile matings

Source: field data of Dr. K. Morgan

TABLE 2.2 CLAN DISTRIBUTION IN SEVEN NAVAJO COMMUNITIES  
(see Figs 2.1-2.7 for dates and sources)

Clan*	Ship	Luka	KC	Gan	Chin	NM	Ram
1	60	9	18	21			71
2	16	10	3				
3		4	7	7	1	1	
4		16	5				
5	1						
6	8	13	1	10		1	
7	50					38	
8	46	4				44	
9	36	57	11		3		
10		29	13		45	5	
11			18				
12	52	11			1		
13	30						
14	28	5	54	1	2	64	
15	15	157	1	12			
16	41	20	69			1	
17	3	3	37	53	13		6
18	1	3					151
19	11	12		3	1		
20	150	106	114	13	2		3
20d**						46	
21	19						1
22	8	104	148	67	1	33	35
23		1					
24	74	44	112				
25	75	45	7	25		1	
27							28
28	92						
29	26	40	100	53	51	102	196
30	4	5	3	1			
32	82	49	14	11	1	181***	17
33	3	5	3	2			
34	2			1			18
35	2	38	71				149
36	20	66	97	49	3	46	13
37		2					239
38			46	19	3		
41		1					
43							12
51a			3				140
52	5						
53	2						

\* Numbering of clans follows Reichard (1928)

\*\* This number introduced by Shepardson and Hammond (1970)

\*\*\*Merges, Navajo and Paiute clans of the same name



## CHAPTER THREE

Ethnographic evidence from Navajo communities shows that the local structure of exchange does not exhibit the statistical degree of marriage choice that is assumed in Levi-Strauss' model of a Crow-Omaha system. By reversing this model, and beginning with the consideration of demographic conditions under which the exchange system must operate, I will show that this empirical observation, as well as other aspects of Navajo social organization, can be theoretically explained by the tendency towards exchange convergence. The demographic model which leads to these results is investigated through the use of computer simulation techniques.

### 1. Analytic considerations

The ethnographic evidence presented in the last chapter suggests the consideration of a model of exchange based on the community. Because of difficulties associated with the demographic analysis of such a model, it will be necessary to use simulation techniques to investigate its properties. It is insightful, however, to develop an analytic approach to the problem before making use of the simulation.

The reproduction of clans in a Crow-Omaha society can be thought of as a stochastic branching process. In a stochastic model of reproduction, the number of children born to each woman is taken to be an identically distributed random variable; equivalently, each woman is assumed to have identical potential fertility, with random social and biological factors intervening to produce differences in the actual number and the sex-ratio of offspring. This stochastic process can be used to derive a non-equilibrium model of exchange dynamics by considering the clan affiliation of offspring, a factor uniquely determined by the affiliation of the

mother. Similar models have been used to analyze the transmission of surnames and of genetic characteristics (Pollard 1973; Moran 1962).

The following result, which is stated here in terms of clan affiliations, is well-known from genetic analysis. Suppose that a population is of finite size and endogamous, and ignore for the moment any effect of marriage rules. If the clan of a child is always identical to that of its mother, then under such circumstances it can be shown that the stochastic branching process described above results in the eventual extinction of all but one of the clans in the initial population. This result can be phrased in a slightly different manner by noting that it implies the certainty that all living individuals will eventually be descended from a common maternal ancestor. The assumption of a constant population size can be relaxed: the analysis applies as long as unrestricted growth does not take place. The magnitude of stochastic effects is, however, inversely related to population size. When a demographic disruption causes a temporary population reduction, these effects can be very substantial. Since such a disruption occurred in the founding of Navajo communities, it seems particularly appropriate to take account of stochastic effects in the analysis of exchange in this society.

The result cited here illustrates the difference between complex and Crow-Omaha exchange. This difference still exists when the number of clans approaches the maximum in the latter case. Since descent is bilateral in complex system, there is, in effect, no rule of transmission for descent affiliation, and hence no possible build-up of large descent groups. Stochastic variation only minimally effects the number of relatives proscribed from marriage with a particular ego as a result of the incest rule, and any individual differences are submerged after one generation. This

contrasts with the cumulative effect of stochastic variation in Crow-Omaha systems. Although the particular line which will achieve dominance in the Crow-Omaha case can only be predicted on a probabilistic basis, the fact that one line will eventually dominate is a deterministic result (i.e. it is certain to eventually occur). This will obviously have an effect on exchange once the marriage rules are introduced into the analysis.

With a large number of clans, the behaviour of a Crow-Omaha system approximates the case without marriage rules. There is a modification, however, as the minimal exchange structure is approached; all the clans remaining in this structure are theoretically necessary for the possibility of exchange. Although illegitimate marriages and births certainly do take place, the constraints of the model dominate empirical patterns, and for the purpose of analysis the marriage rules can be regarded as rigorous. The marriage constraints make it difficult to determine the effect of demographic variation on the minimal exchange structure in an analytic manner, and for this reason a simulation model is used to investigate this question here. The remainder of this section will provide a theoretical motivation for the approach adopted in the simulation.

The first step in the demographic analysis is to determine if the stochastic convergence of the exchange structure is of sufficient magnitude to have social consequences. If, for instance, the emergence of the minimal structure took place so slowly that it would be expected to be masked by other historical factors, then the analysis of the convergence, while remaining formally correct, would become devoid of social import. The results of the simulation study, modelling a Navajo community with a small founding population restricted in terms of clan affiliations, assures that this is not the case. There is a very rapid convergence of the exchange structure when it is assumed that clans do not fission and that

the population is endogamous. The fact that these limiting assumptions are never completely met in a real society may, in some circumstances, be explicable on the basis of the exchange convergence. Since a large portion of the population is excluded from inter-marriage in the minimal structure, further demographic variation can place heavy constraints on the possibility of marriage. This demographic problem introduces the necessity of finding a social solution. In the Navajo case, the constraints are overcome by the possibility of inter-community marriage. Since communities are heterogenous in terms of clan affiliations, this strategy assures the creation of marriage partners.

Some researchers have stressed that similar restrictions on marriage partners can exist in systems of elementary exchange when the population size is small (cf. Godelier 1976). The simulation results comparing the two cases shows, however, that a qualitative difference exists between the negative aspects of Crow-Omaha and elementary exchange in this regard. This difference leads to the conclusion that demographic constraints will affect Crow-Omaha systems over a much wider range of population sizes. Of course, in the case of the Navajo the constraints act only on the community level, thus allowing the possibility of the immigration strategy mentioned above.

The explanation of inter-community marriage in terms of a strategy to avoid exchange constraints requires some further clarification. There are many motives, most of which are economic, that can lie behind the choice to immigrate into a specific community. The Navajo have a herding economy in which the local need for labour and the availability of resources are major factors in determining the possibility of immigration. Interpreted in the light of such economic constraints, the relationship between marriage and immigration can be explained on the basis of the importance

of kinship ties in allowing access to the traditional economy within a community, and for this reason, it may seem possible to avoid the question of exchange constraints altogether; in this situation the choice of either interpretation of immigration at least seems arbitrary. However, the ultimate purpose of providing a separate analysis of exchange is to consider a range of incompatibility between the systems of social and production relations.

Although the full development of this theme is beyond the scope of this thesis, the following example will illustrate the importance of such considerations. It is possible to speculate theoretically on the effects of restricting the resource base of a community so that further immigration into it is not economically feasible. As a result of the analysis of the exchange system, this would be expected to lead to increasing constraints on the possibility of marriage within the community. When this situation is examined ethnographically the prediction of the model is confirmed. Thus, in discussing the Navajo Mountain community, Shepardson and Hammond note that

...this little community is increasingly subject to stress and strain. The sharp increase in population, together with an overutilization of all available land, endangers the pastoral base. Young couples find it more and more difficult to set up households because of the economic problems and rules of clan exogamy which limit the number of eligible spouses in this much inter-married community. In 1961, 30 men and 22 women in Navajo Mountain had never been married--a disproportionately large number of celibates in a society which is given to early marriage (Shepardson and Hammond 1970:24).

In this situation, the economic advantages of alliance to the community are minimal, and in the resulting absence of external marriage, the constraints of the exchange system have become dominant. Another example in which consideration of the exchange structure and alliance pattern

can give insight into Navajo production relations is developed in Appendix III.

The question of the relationship between exchange and migration can also be approached using the simulation model. As mentioned above, the results of the endogamous simulation runs show that the constraints of the exchange system require a social solution. In the absence of this solution, the possibility of marriage eventually disappears. Since the simulation adheres strictly to the exchange rules, once this state is reached the population will collapse due to the fact that no children are born. The Navajo solution can be modelled by allowing in- and out-migration if (and only if) the clan prohibitions are seriously restricting the possibility of marriage formation. (By allowing migration only in this situation, the simulation assumes a direct relationship between immigration and exchange.) Immigrants are always unmarried, and have their clan affiliations chosen without regard to clans already present in the community; this increases the likelihood of marriage with a community member. Under these conditions, the simulation results show that a reasonable level of migration overcomes the constraints of the exchange system.

This form of immigration also provides an explanation for the characteristic skewed distribution of clans empirically observed within each community; the simulation produces similar distributions for the following reason. An initial variance in clan sizes is expected as a result of stochastic effects. The members of the largest clans in the community will, on the average at least, have the greatest degree of restriction on marriage choice. If some immigration is allowed, then the members of these clans will be the most likely to be involved in an inter-

community marriage. Since the clans of immigrants have been randomly chosen, the offspring of female immigrants will be widely distributed in terms of clan affiliations, while the offspring of male immigrants will be concentrated in the largest clans. Thus immigration tends both to increase the size of clans which are already large, and to increase the total number of clans within the community. However, to be compatible with the immigration pattern, it is necessary to restrict emigration to unmarried individuals. Although this results in an increased probability of emigration for the members of the largest clans, the loss is more than offset in the case of a growing population, such as the Navajo, by the gains due to immigration. The transformation of the clan distribution described above takes place, therefore, in the context of an overall increase in community size, a result which is in agreement with Aberle's analysis of the government survey data.

Finally, it is of interest to examine two statistical patterns of preference which appear in the minimal structure of exchange. First consider the equilibrium model in which, for the purpose of exchange, all clans in the minimal structure are represented by a single sibling pair in each generation. Fig 3.1 shows that under the Navajo exchange rules, marriage into one of the grandfathers' clans is necessary, and that siblings must marry into the same clan at least every second generation. Since the marriage destiny of the sib-group is not uniquely determined in the Navajo system, a dynamic model is more appropriate. Yet even in this case, it is clear that a maximal extension of the exchange pattern exists if attention is restricted to the minimal structure. Since there are only four clans, siblings must still marry into one of the grandfathers' clans, thus assuring a 50% correlation in the tendency for siblings to choose a partner from the same clan. (If the minimal exchange

structure was observed empirically, a pattern lying somewhere between these two extremes would be expected.) This analysis explains the two statistical preferences discussed at the end of the previous chapter. As outlined above, empirical patterns necessarily deviate from that implied by the minimal exchange structure, but the ethnographic data shows that this structure still remains locally dominant.

The convergence of the exchange system as discussed here is independent of the specific demographic history of the Navajo population, and will be important in other Crow-Omaha societies even under "paleolithic" demographic conditions. The strategy of extending the range of marriage choice through inter-community exchange is, in contrast, a particular feature of the Navajo historical and social situation. In a more restricted population without heterogeneous localities to draw on, another solution to the exchange problem would have to be found. Perhaps the most likely is rapid clan fissioning. The possibility that this fissioning would result in the development of a contradiction between the requirements of the system of exchange, and the desire to maintain production rights determined by membership within a larger descent group, suggests that it is generally inappropriate to use an equilibrium model in the analysis of Crow-Omaha exchange.

## 2. Simulation results

The results given in this section were obtained from a Fortran IV simulation routine made available to the author by Dr. K. Morgan, and implemented on the Amdahl 470 V16 at the University of Alberta. The simulation uses a modification of a program previously developed by Morgan (1973b). Demographic schedules and other key aspects of the program are described in Appendix I. Because several of these aspects do



not conform exactly to known aspects of Navajo social organization and demography--for instance, population growth is lower in the simulation--justification for their use is also provided in the appendix.

Simulation runs were initiated with a small, randomly generated population in order to model the founding of a Navajo community. Unless otherwise specified, the initial population is drawn from a possible eight clans; when migration is allowed, the clans of immigrants are generated from a total of thirty. Marriages are subject to one of the following three levels of clan exclusion rules by specifying a parameter at the initialization of a run:

Level 2: Navajo exchange rules prohibiting marriage between persons having a common entry in the two-dimensional marriage vector.

Level 1: Clan exogamy only.

Level 0: No clan prohibitions.

All runs include an incest rule which prohibits marriage between a male ego and his Mo, MoSi, and FaSi, and between a female ego and her Fa, FaBr, and MoBr, and between cross and parallel cousins. (These restrictions refer only to biological relationships.) Some of the incest exclusions are redundant at levels 1 and 2 of the marriage rules, but at level 0 they transform the exchange structure into a complex type.

Runs are continued for six hundred simulation years unless the population grows to over seven hundred, or declines to zero before this. A simulation year is defined as one cycle in the application of the demographic and marriage subroutines. This time unit is not equivalent to a real year in terms of population growth because of limitations in the demographic parameters employed in the model, a factor which does not qualitatively affect the results described here. The simulation is

designed to conservatively model the effects of the true demographic variance over any given time period (see the discussion in Appendix I).

Two statistics are used to show the effects of marriage rules on the simulation. The first is population growth. With the fixed demographic schedules employed in the program, the only factor that can cause consistent variation in growth under different levels of the exchange rules is differing possibilities of marriage formation. Population growth can therefore be used to compare the effects of the different rules in various simulated social situations.

The second statistic, which will be denoted as  $R$ , is used to give further insight into the relationship between population growth and the marriage constraints. For any year of the simulation run,  $R$  is defined to be the average number of persons eligible but unable to marry in the previous ten years, divided by the total population size at the end of the ten-year period. (Eligibility criteria depend on age as well as marriage status, and are described in the appendix.).

$R$  is a measure of the proportion of adult population which is unmarried in a given period, and thus its expectation is never zero, but since the program is designed to maximize the number of possible marriages that can be formed, it should be small when marriage constraints have no significant effect. The correlation between  $R$  values and population growth is discussed below.

Chance imbalances in the sex-ratio in the total population can affect the possibility of marriage in any system of exchange, and it is important to show that demographic constraints attributed specifically to Crow-Omaha rules are not actually a result of this factor. It is also necessary to show a difference between the effects of the prohibitions

in Crow-Omaha exchange, and of the exogamy rule in elementary structures. Recall that it is the positive (i.e. prescriptive) aspects of an elementary system which are principally affected by demographic variation. If the constraints introduced by the Crow-Omaha rules are to be considered significant, it should therefore be possible to show a qualitative difference in the effects in the two categories of exchange.

The necessary results can be obtained by comparing endogamous population runs under each of the three possible levels of marriage rules. Level 1 rules (clan exogamy) model the negative aspects of elementary exchange, but it is possible to duplicate fully reciprocal alliance by allowing only two clans into the population.

Fig 3.2(a) shows the range of population growth exhibited by a series of five runs for each of the three levels of marriage rules. Each run was initiated with a total population of twenty-four, equally divided between males and females. Level 0 and Level 1 runs show similar characteristics, alternating between population growth and collapse due to chance imbalances in the sex-ratio. In contrast, all Level 2 (Crow-Omaha) runs collapse quickly after an initial rise caused by the fact that the founding population is chosen to have maximum fertility (see Appendix I). This rapid collapse shows that, even under such optimal initial conditions, the effects of the marriage constraints are dominant. The relationship of population collapse to marriage constraints is also shown in Fig 3.2(b) where values of  $R$  are graphed against simulation years. A correlation between large values of  $R$  and population decline can be found by comparing 3.2(a) and (b).

Stochastic variation in the sex-ratio can be reduced by increasing this initial population size. Fig 3.3 shows the difference between

Level 1 and Level 2 runs with an initial population of fifty. While all Level 1 runs now survive, the behaviour of Level 2 runs remains unchanged. Even with an initial population of one hundred no change occurs in the qualitative pattern of marriage constraints and rapid collapse under Level 2 rules as is also shown in Fig 3.3. A limited number of characteristic examples have been displayed in this figure because very little variation exists between runs initiated under similar exchange rules and population sizes. This strategy of summarizing results is used below whenever such equivalences are possible.

The differences between Crow-Omaha and elementary exchange can be made more explicit by initiating runs with a fewer number of clans. With four clans, runs under Level 2 rules directly model the minimal exchange structure. Similarly, runs under Level 1 rules with two clans model reciprocal exchange. Fig 3.4 allows comparison of runs having an initial population size of one hundred. Again, the demographic constraints are qualitatively more significant for the Crow-Omaha runs.

The reasons for this difference have been discussed above. Theoretically, elementary systems are subject to a convergence, and resulting demographic constraints similar to those in Crow-Omaha exchange, but the simulation shows that speed and effect of these results are quite different in the two cases. In a system of elementary exchange, the effects of the reduction would generally be masked by the intervention of other social factors. Only if the population size is sufficiently small will the limits to clan exogamy become apparent.

The simulation program allows the specification of basic annual probabilities for migration. Immigrants are introduced as discussed above so as to maximize the possibility of marriage within the community.

The initial annual probability of immigration is scaled separately for each sex by multiplying by the proportion of individuals of the opposite sex eligible but unmarried in that year. Emigration probabilities are scaled similarly, but by the proportion for the same sex. Only childless and unmarried individuals are subject to possible emigration. This scaling assures that migration is dependent on the degree of marriage constraints.

Fig 3.5 shows the statistics for representative runs under various basic migration levels. These runs were initiated with a population of twenty-four, and subjected to Level 2 marriage rules. At the lowest levels of migration--maximum immigration of .01 and maximum emigration of 0.25--the population size tends to stabilize due to predominance of out-migration. At higher levels of immigration, all runs show positive growth; changes in the emigration level from .1 to .5 were found not to be significant for this qualitative behaviour. The values of R in various runs indicate that the major effect of immigration is to reduce the overall degree of marriage constraints. Yearly averages of migration in the simulation runs shown in Fig 3.5 are indicated below the figure. The levels of migration necessary to overcome the effects of the exchange convergence are sufficiently small to offer a meaningful model of the Navajo situations.<sup>1</sup>

Fig 3.6 shows clan distributions in typical endogamous runs under Level 1 and 2 marriage rules. The convergence towards the minimal structure is apparent in the case of Level 2 rules despite the confounding with population decline. Fig 3.7 shows the characteristic skewed clan distributions which result from Level 2 rules when migration is allowed. The simulated distributions are visually similar to the empirical distributions shown in Figs 2.1 - 2.7. The degree of skewness depends on the

overall size of the community, and not on specific migration levels. These results confirm the discussion on migration given in the previous section.

### 3. Conclusion

The conclusions drawn in Chapter One regarding the effect of demographic variables on a system of Crow-Omaha exchange have been validated through the use of a simulation study in this chapter. The minimal structure appears as a dominant statistical pattern of exchange in Navajo communities. The strategy of inter-community marriage can be interpreted as a solution to the effect of demographic constraints caused by the exchange convergence. The combination of inter-community marriage and local convergence of the exchange system leads to the characteristic skewed clan distributions that are empirically observed within Navajo communities.

#### Notes to Chapter Three

1. The migration in the simulation runs can be compared with that at Ramah. Between 1890 and 1950, 72 individuals immigrated into the community, while 75 emigrated from it, giving a yearly average of 1.2 and 1.23 respectively. (These figures include 22 immigrants who left the community after the death of their spouse.) As might be expected the migration values for Ramah are higher than those observed in the simulation. This is due to the conservative nature of the growth rates used in the simulated population. The migration data from Ramah is derived from Kluckhohn (1956).

FIG 3.1 EQUILIBRIUM MODEL OF THE MINIMAL STRUCTURE SHOWING A POSSIBLE INTER-GENERATIONAL EXCHANGE ALTERATION

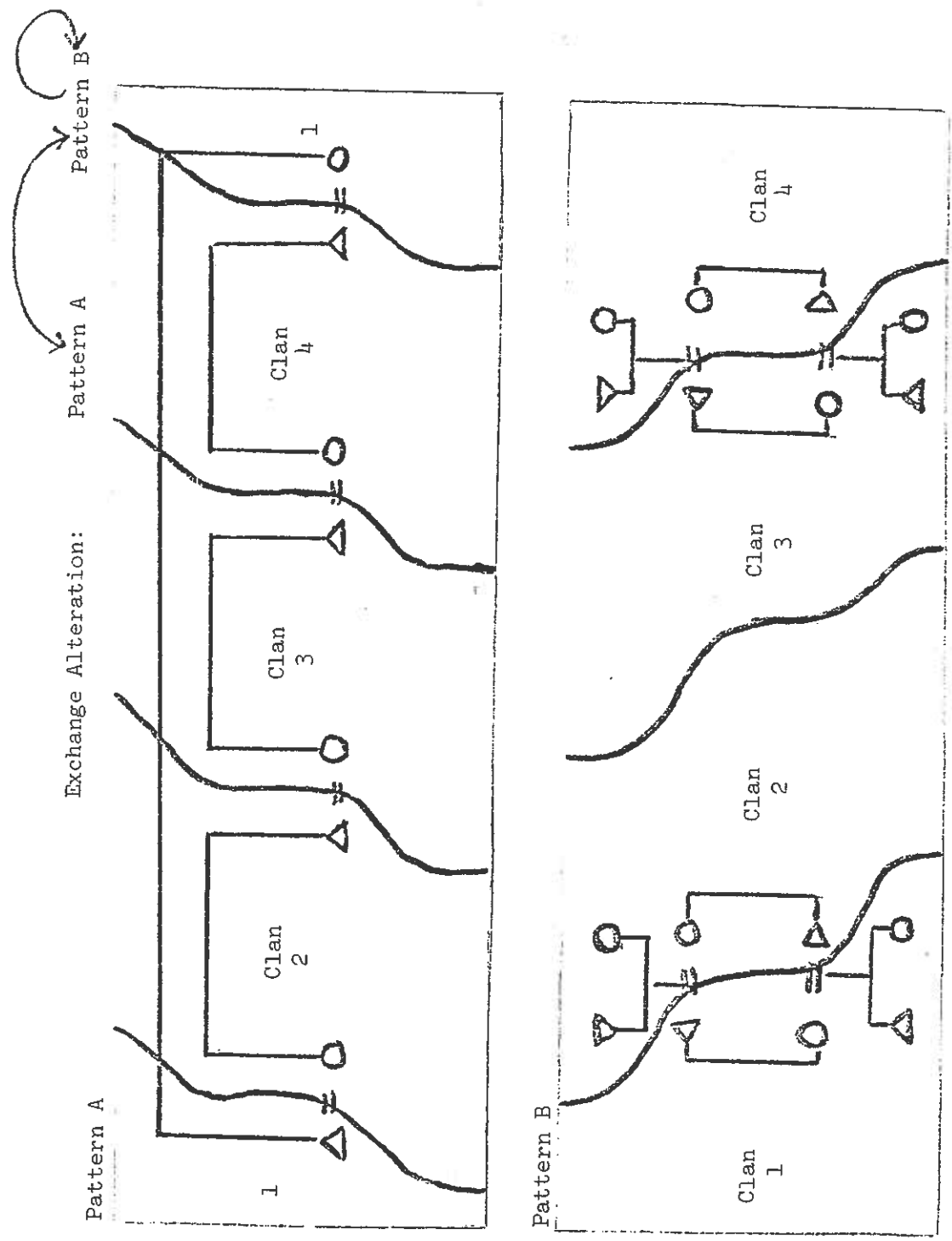
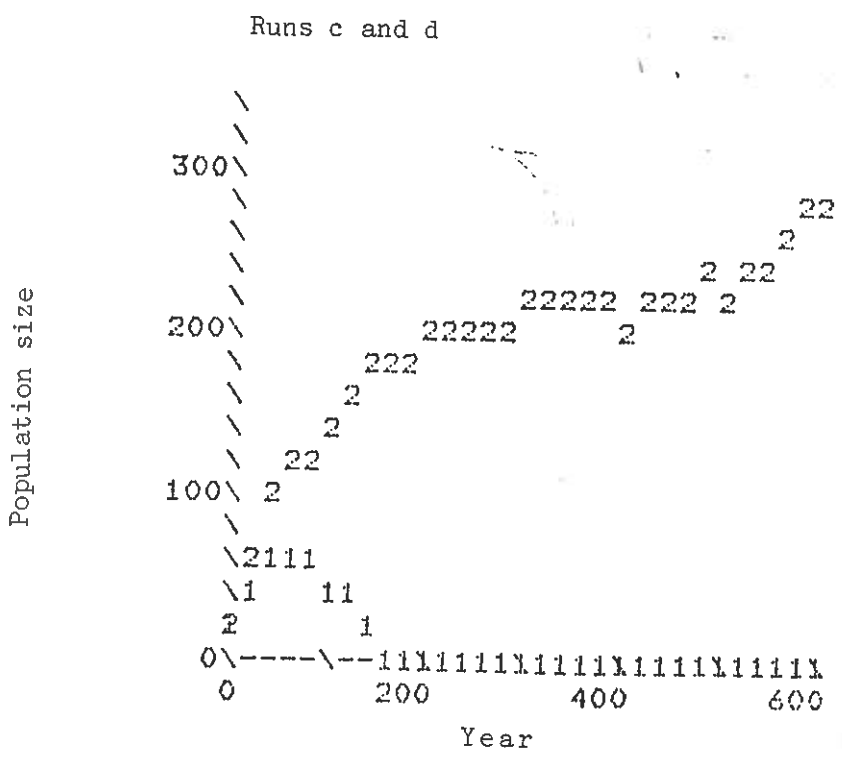
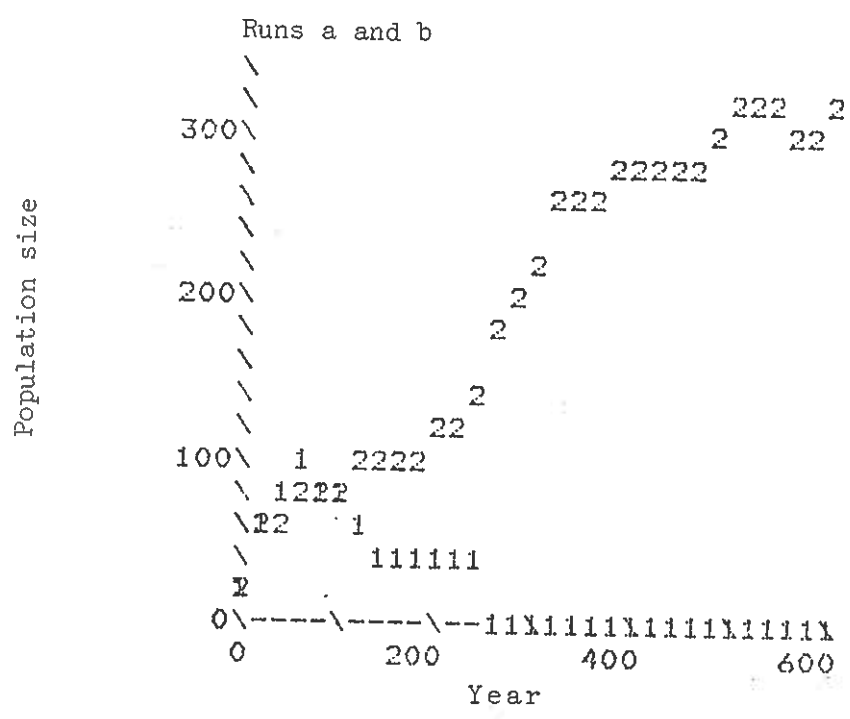


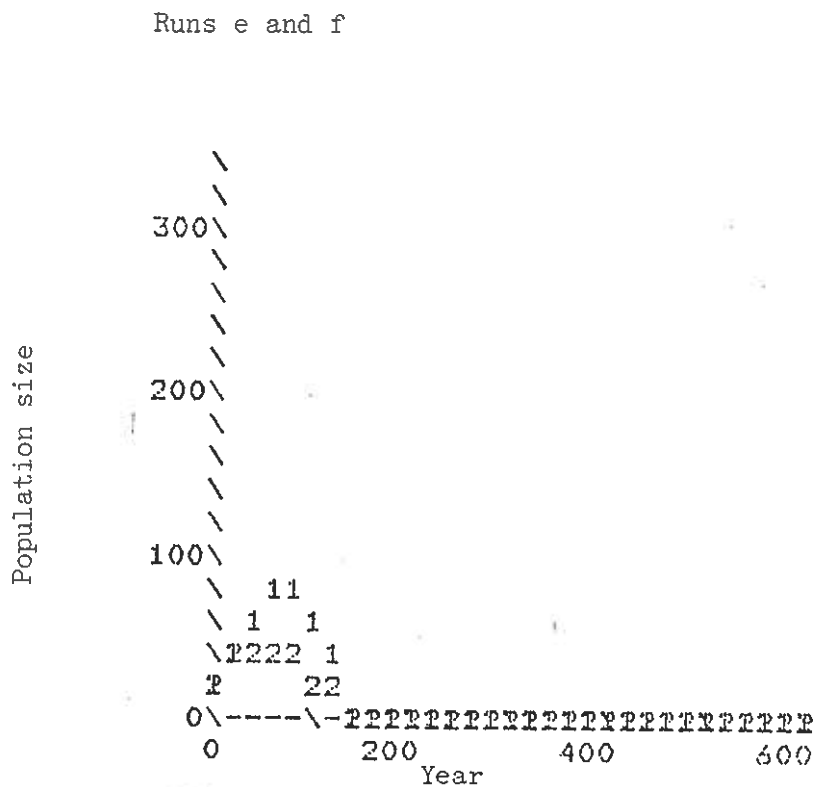
FIG 3.2(a) POPULATION GROWTH IN ENDOGAMOUS RUNS:  
INITIAL POPULATION OF 24



(cont....)

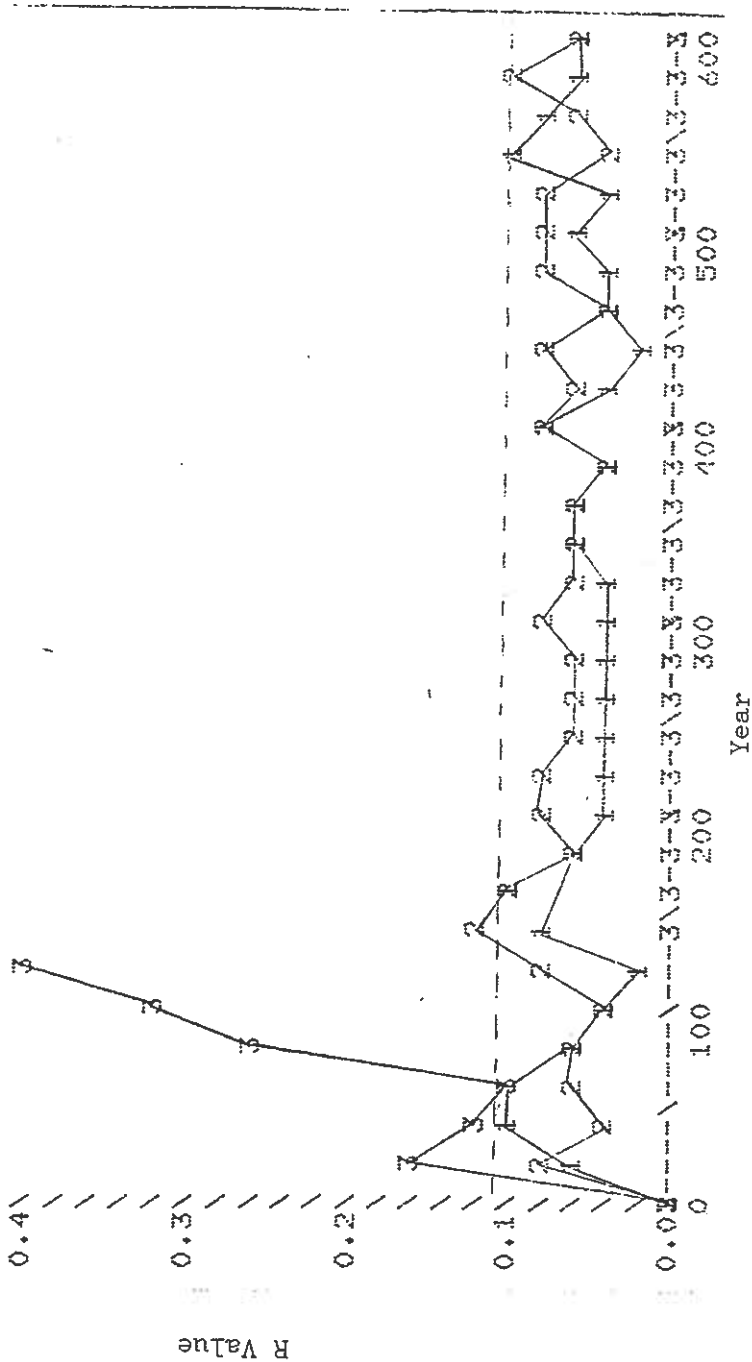


FIG 3.2(a) (cont.)



a and b = rule 0  
 c and d = rule 1  
 e and f = rule 2

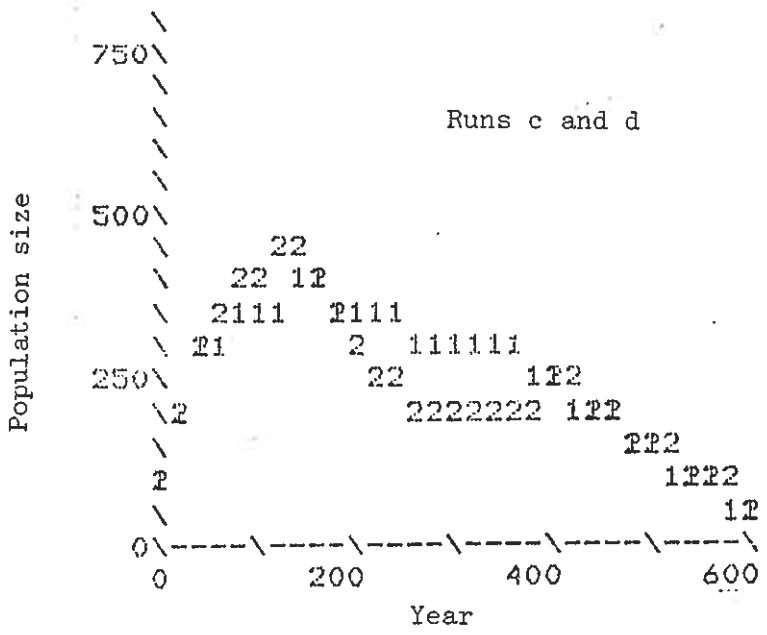
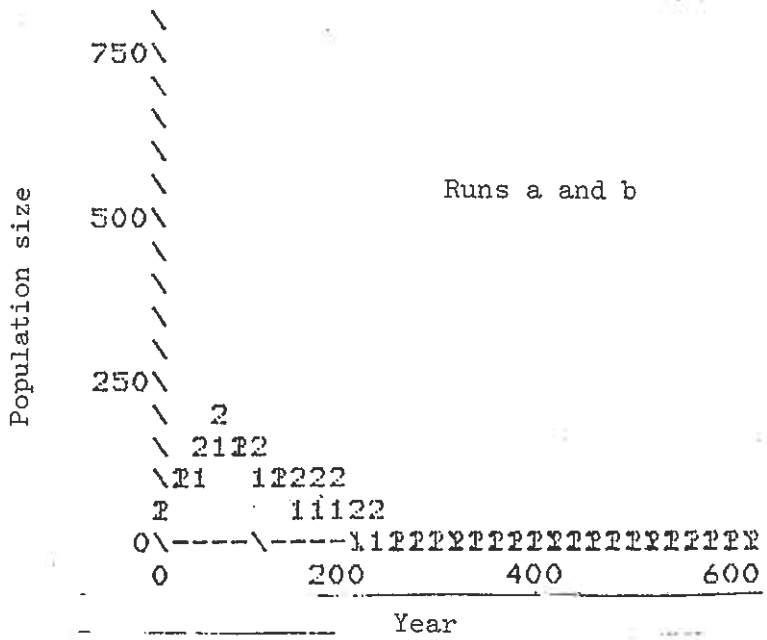
FIG 3.2(b) R LEVELS FOR MAXIMAL GROWTH ENDOGAMOUS RUNS IN 3.2(a)



- 1 = rule 0
- 2 = rule 1
- 3 = rule 2

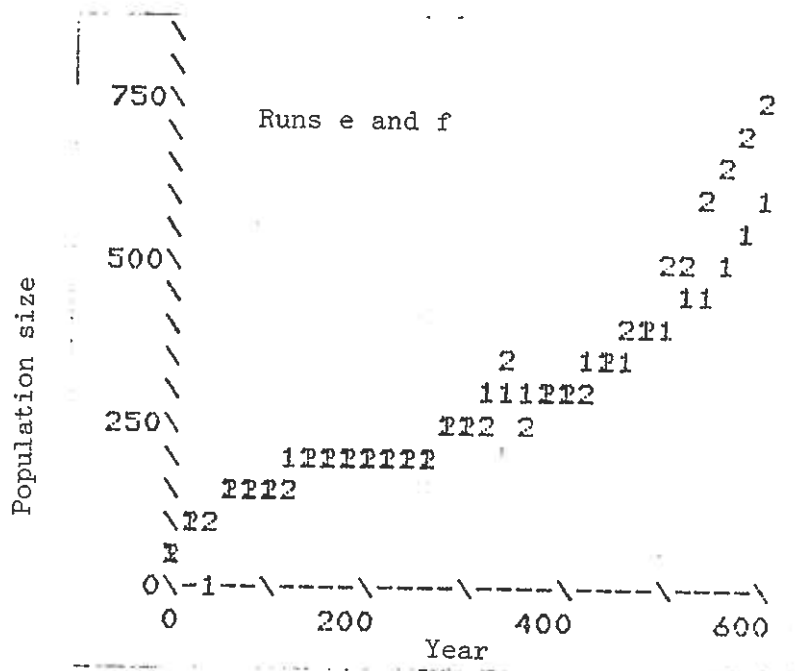
--- indicates R=0.1 or 10% of the population eligible but unable to marry

FIG 3.3(a) POPULATION GROWTH IN ENDOGAMOUS RUNS: INITIAL POPULATION OF 50 AND 100



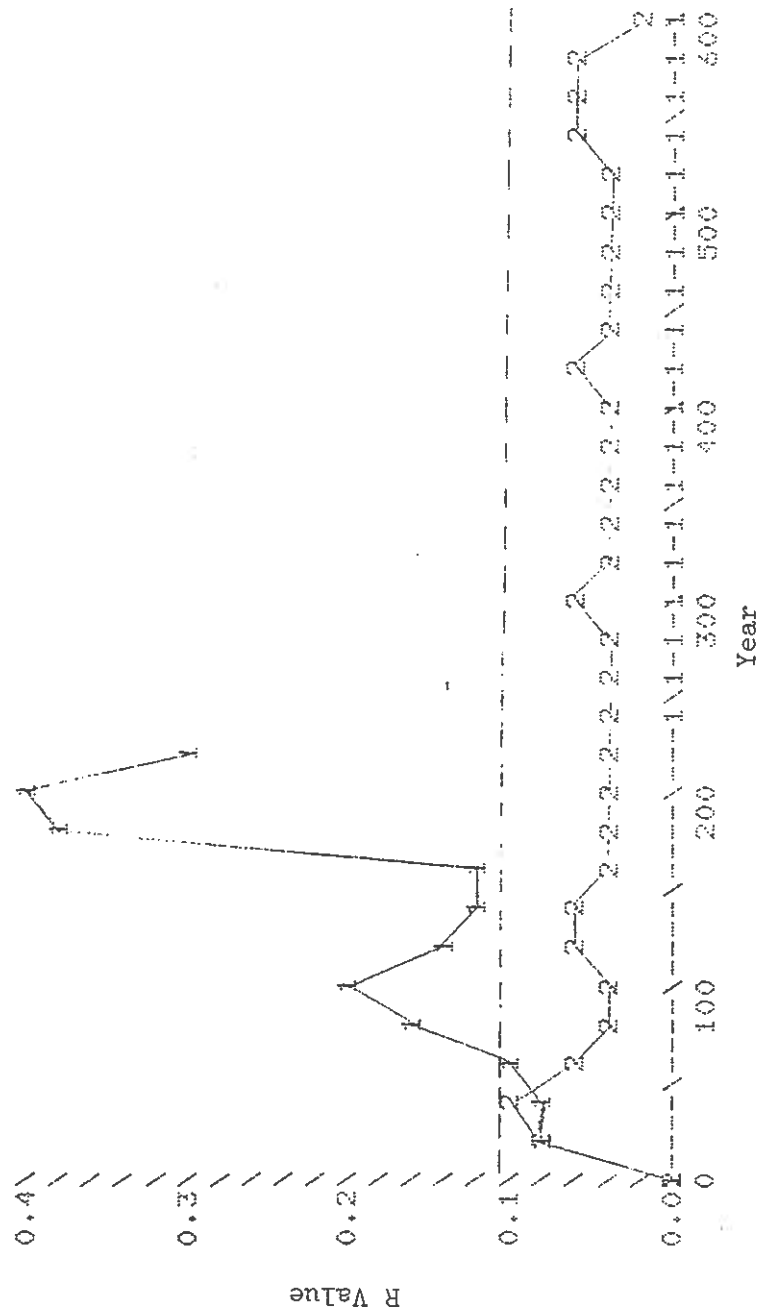
(cont...)

TABLE 3.3(a) (cont...)



a and b = rule 2, in. pop. 50  
 c and d = rule 2, in. pop. 100  
 e and f = rule 1, in. pop. 50

FIG 3.3(b) R LEVELS FOR MAXIMAL AND MINIMAL GROWTH RUNS IN 3.3(a)



1 = rule 1  
 2 = rule 2, in. pop. 50  
 ---indicates R=.1 or 10% of the population eligible but unable to marry

FIG 3.4(a) COMPARISON OF MINIMAL STRUCTURE WITH RECIPROCAL EXCHANGE: RESTRICTED NUMBER OF INITIAL CLANS AND INITIAL POPULATION OF 100

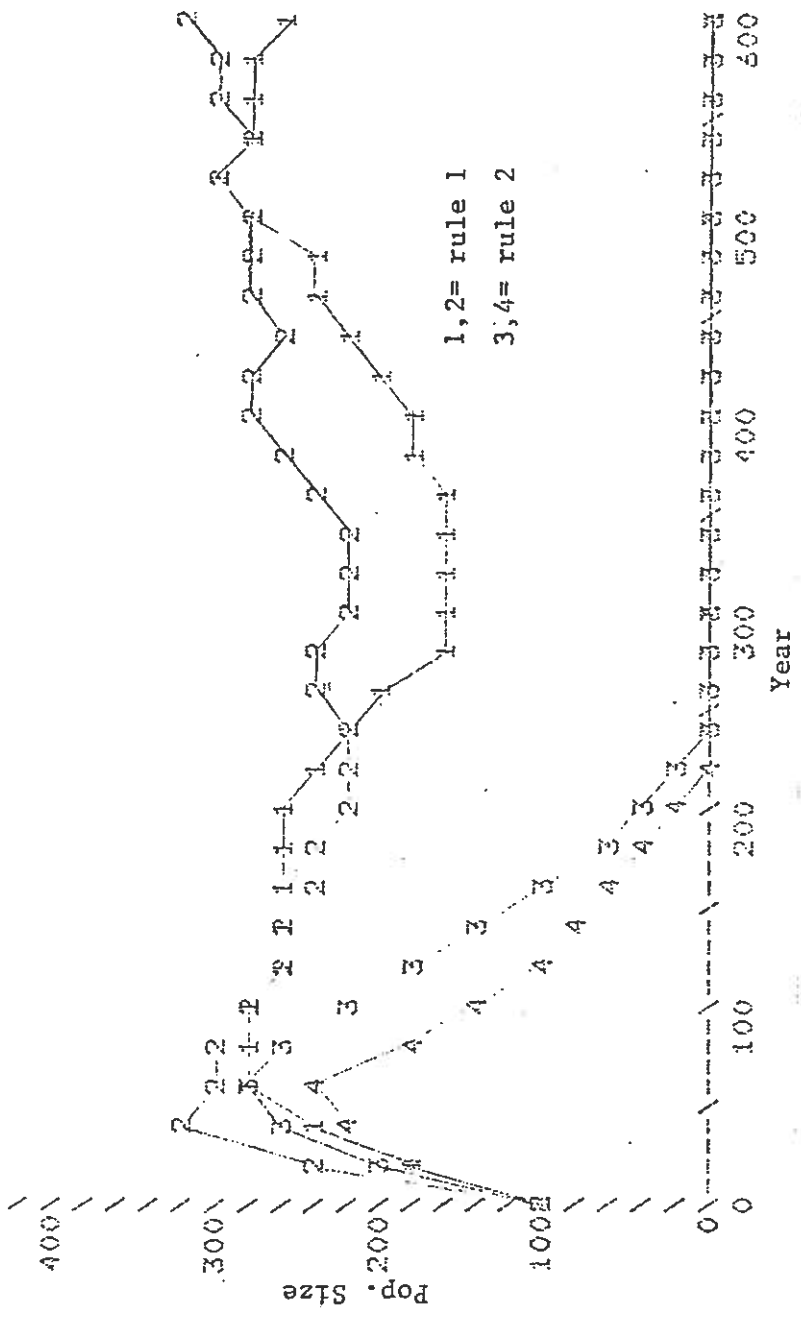


FIG 3.4(b) R LEVELS FOR MAXIMUM GROWTH RUNS UNDER EACH RULE IN FIG 3.4(a)

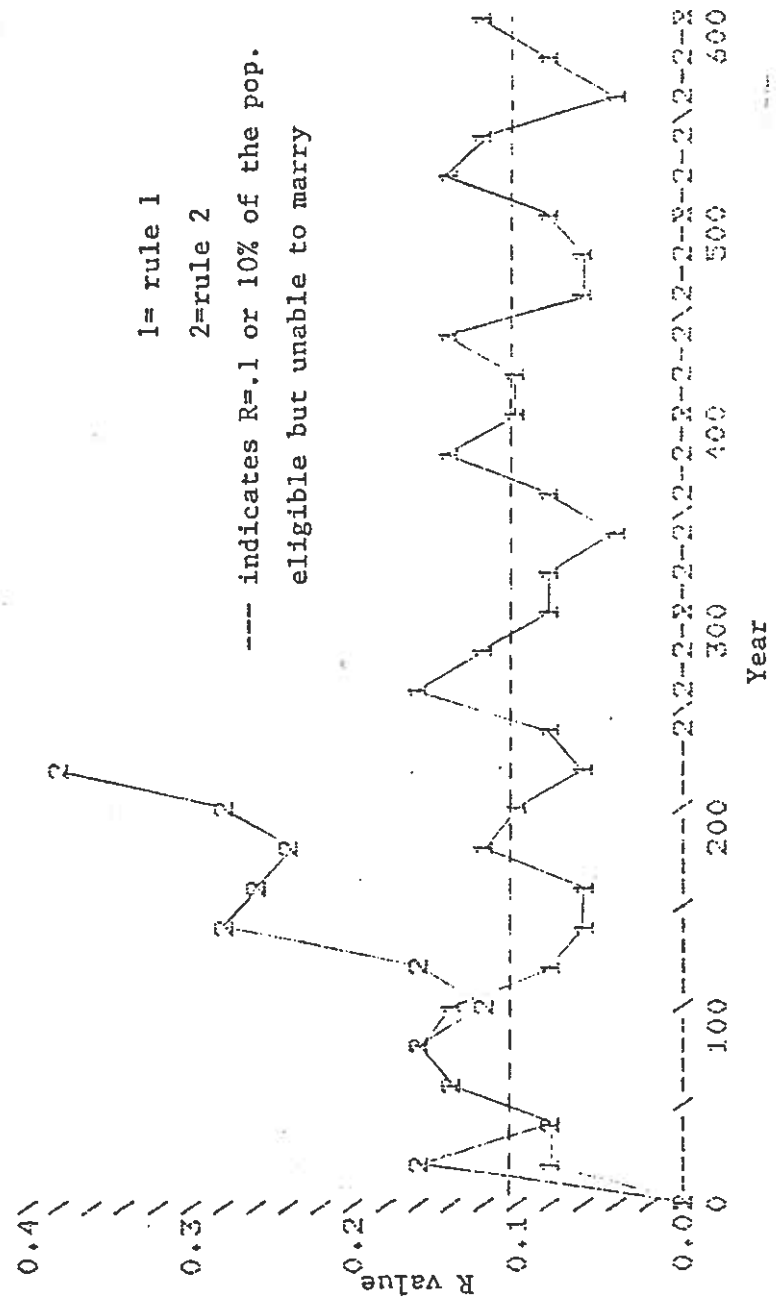
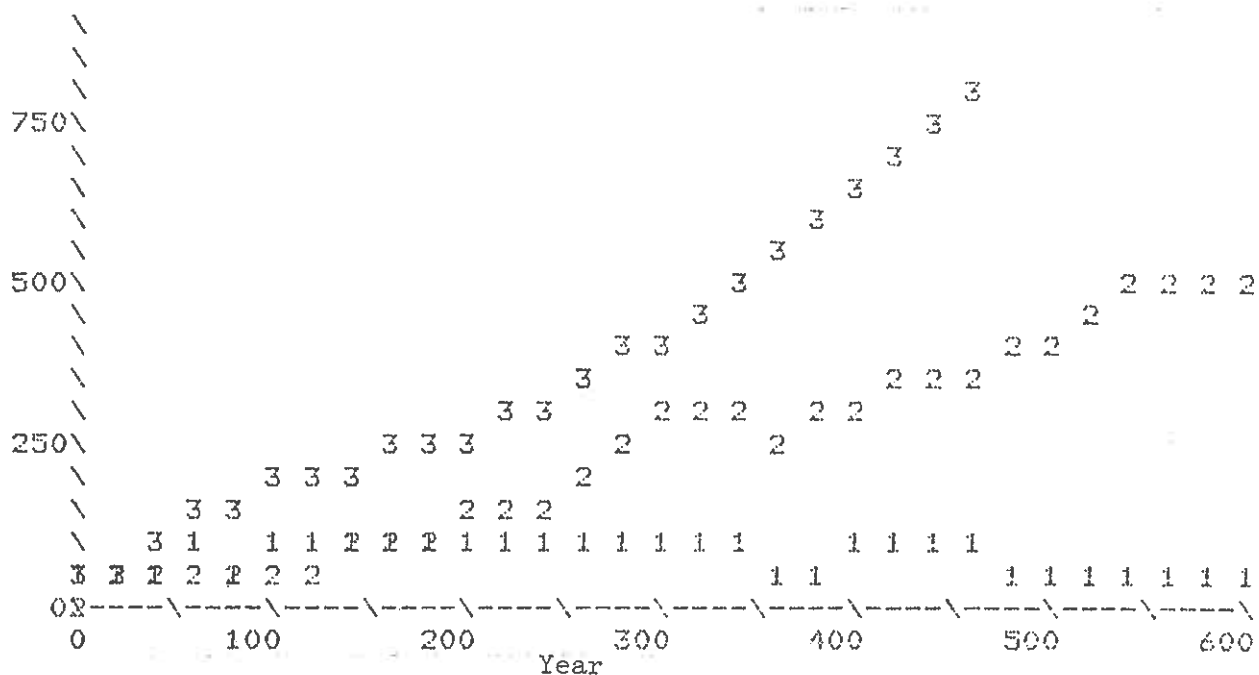
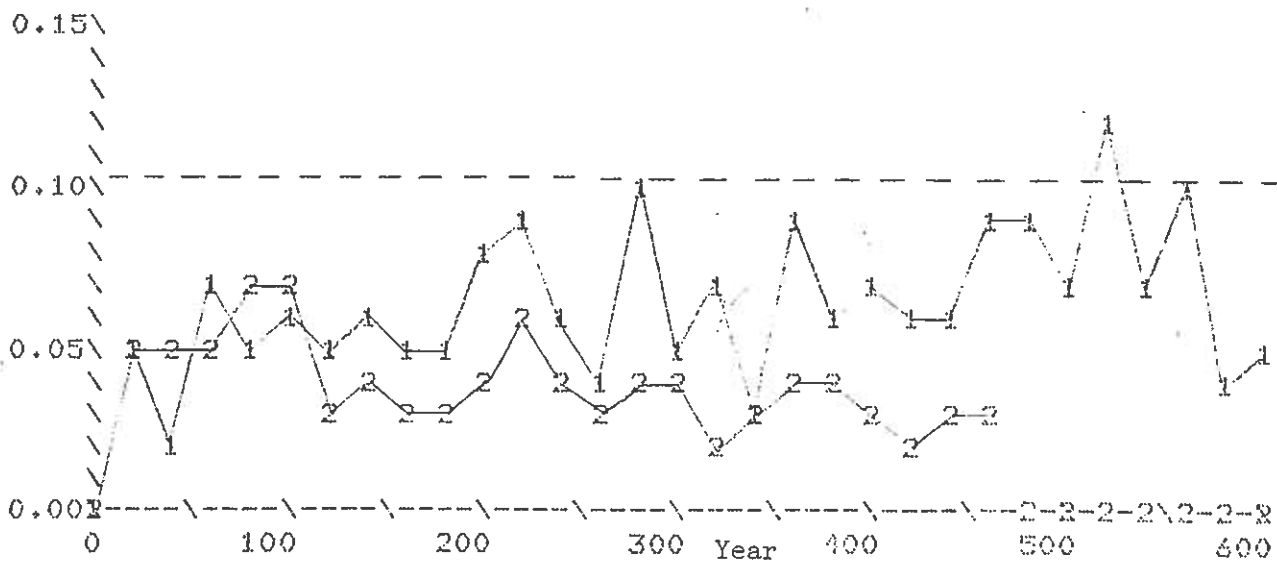


FIG 3.5 POPULATION GROWTH AND R VALUES IN TYPICAL MIGRATION RUNS



1=im. level .1, em. level .25      Average annual im. 1=.114 em.1=.35  
 2=im. level .25, em. level .25      2=.24 em.2=.4  
 3=im. level .5, em. level .25      3=.48 em.3=.41



1=im.level .1, em. level .25 (minimum growth from above)  
 2=im.level .5, em. level .25 (maximum growth from above)  
 ---indicates R=.1 or 10% of the population eligible but unable to marry



FIG 3.6(a) CLAN DISTRIBUTION IN A TYPICAL ENDOGAMOUS RUN: RULE 2 AND INITIAL POPULATION OF 100

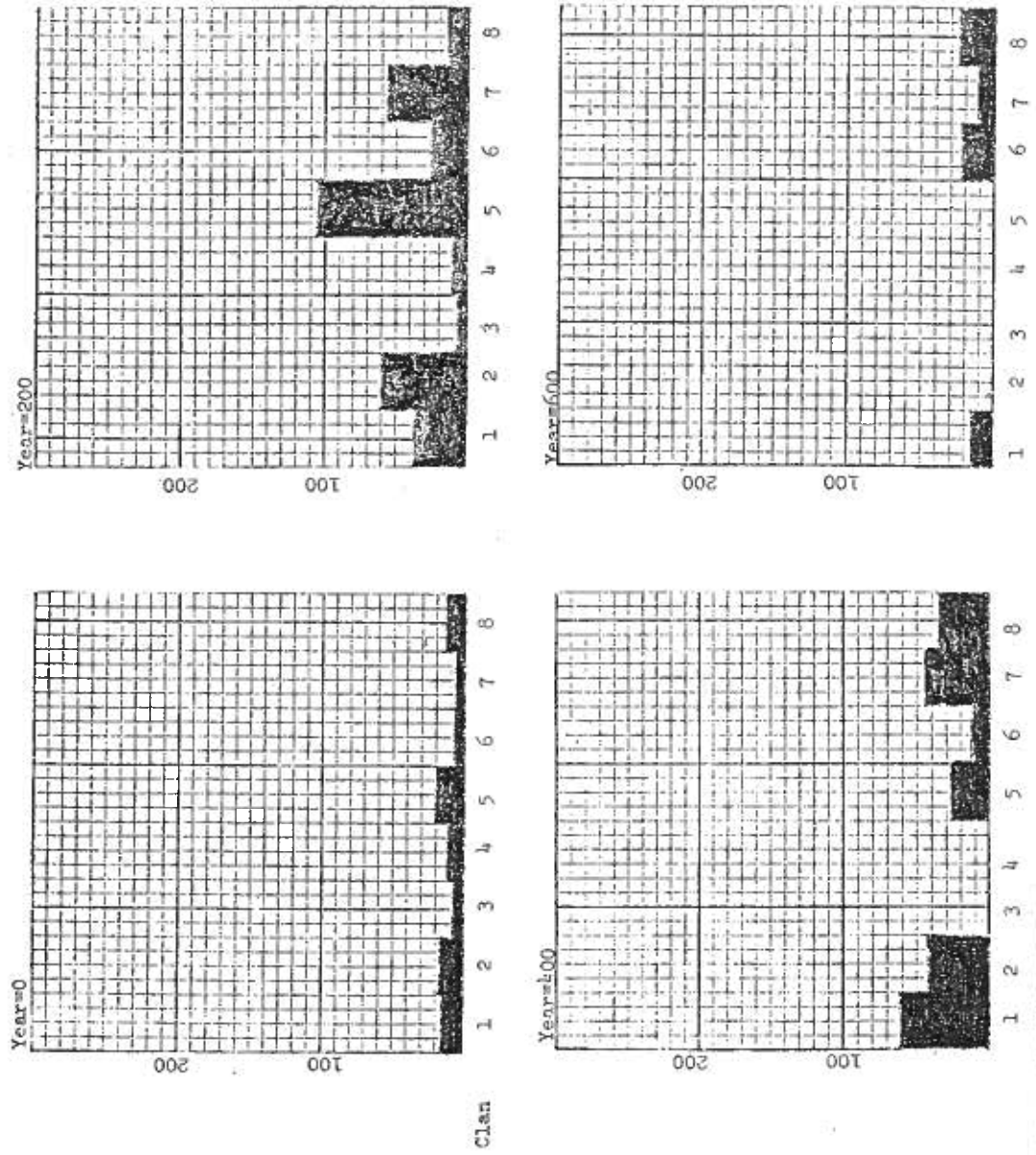


FIG 3.6(b) CLAN DISTRIBUTION IN A TYPICAL ENDOGAMOUS RUN: RULE 1 AND INITIAL POPULATION OF 50

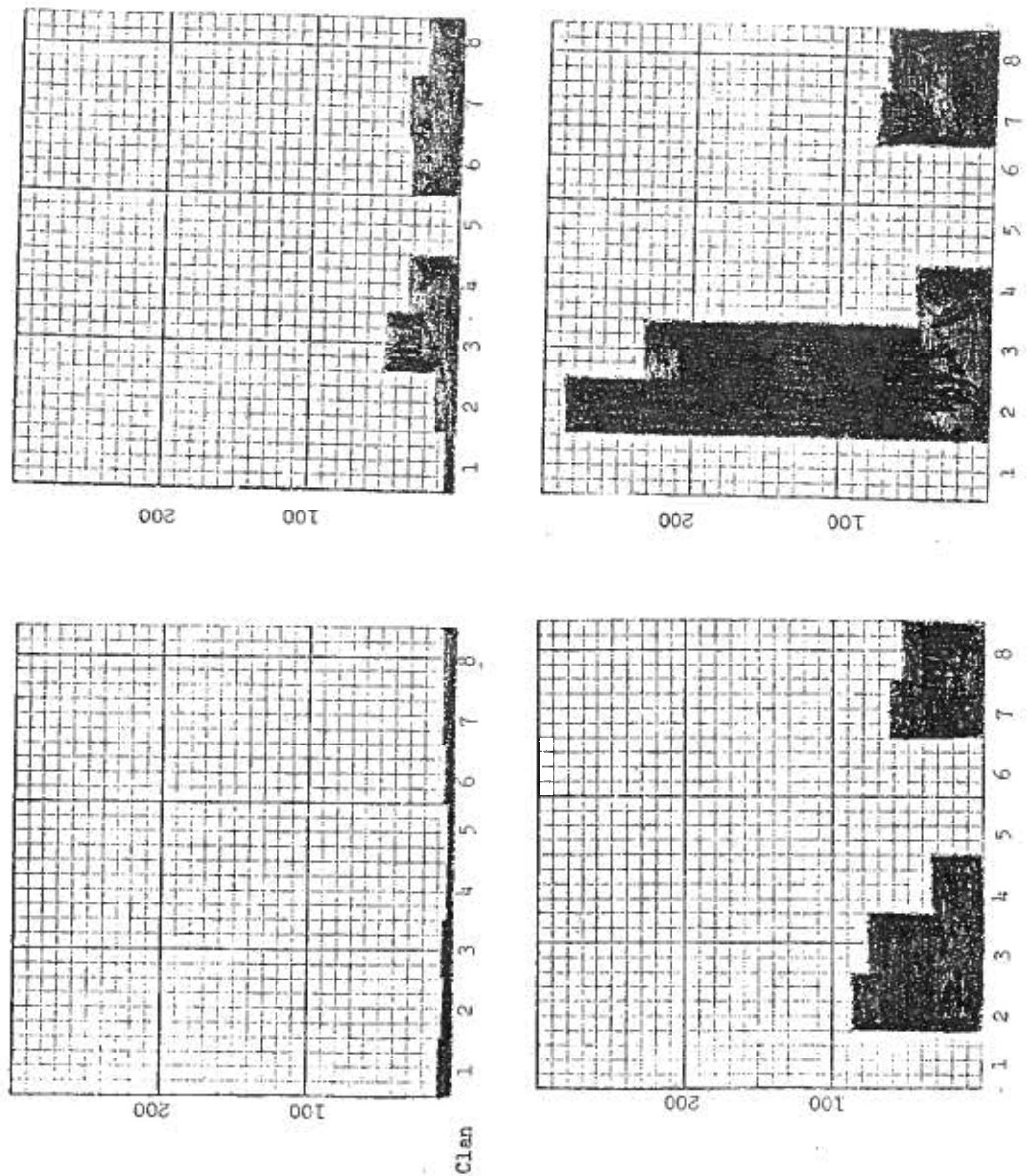
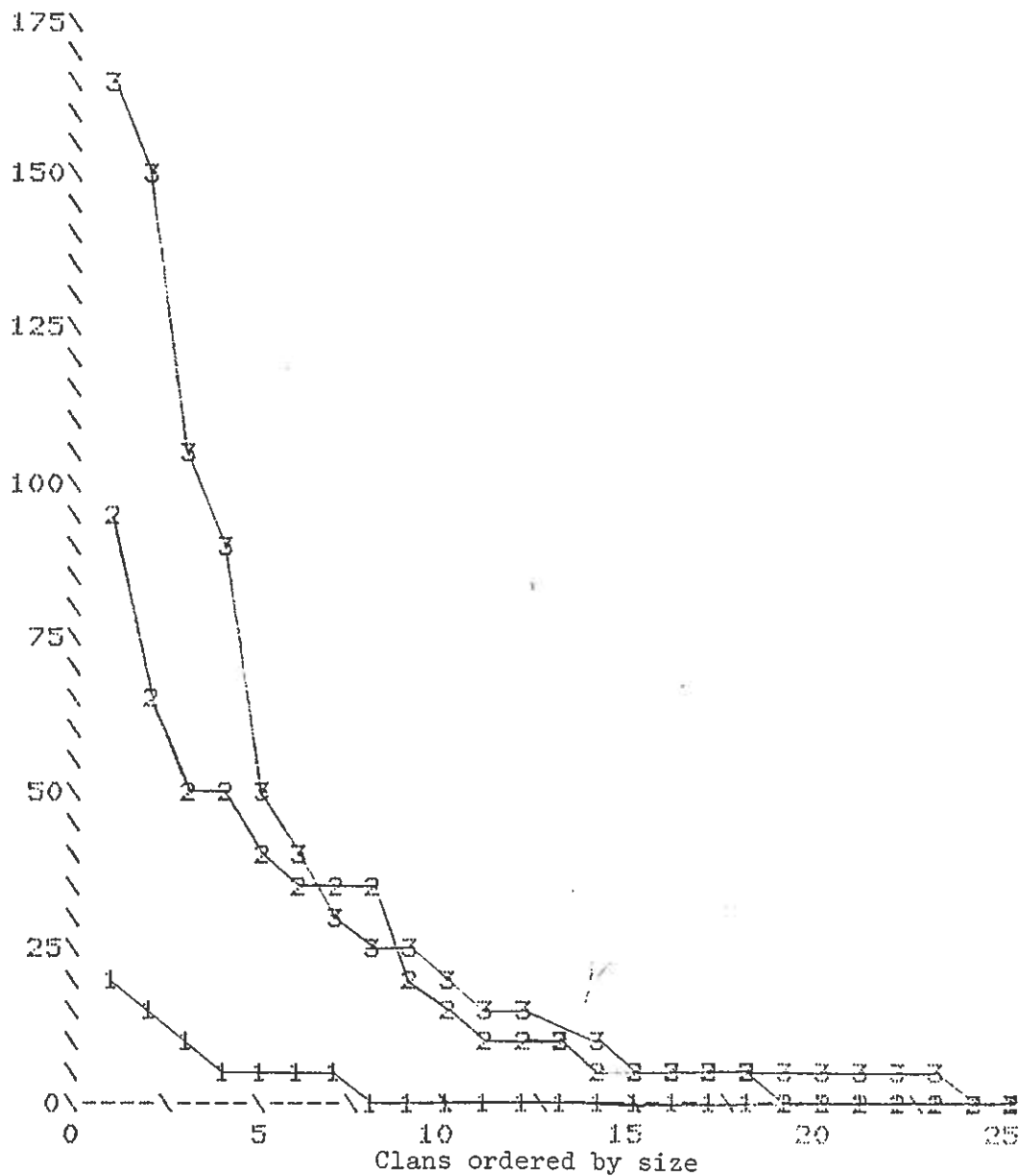
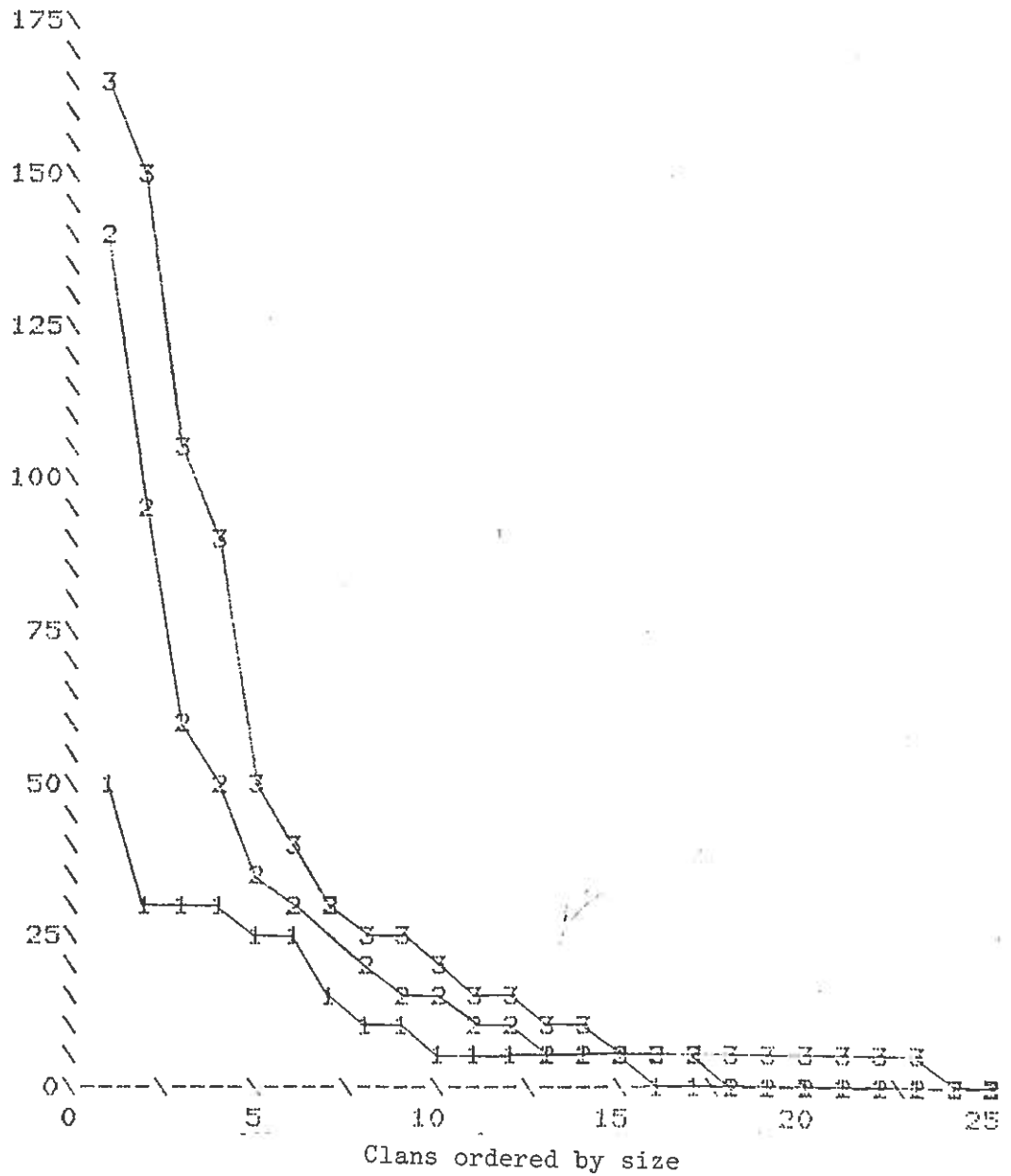


FIG 3.7(a) CLAN DISTRIBUTIONS AT ENDING YEAR IN TYPICAL MIGRATION RUNS  
(ORDERED BY MAGNITUDE)



1=im.level .1, em. level .25  
 2=im.level .25, em.level .25  
 3=im.level .5, em. level .25

FIG 3.7(b) CLAN DISTRIBUTIONS AT VARIOUS YEARS IN A TYPICAL MIGRATION RUN (ORDERED BY MAGNITUDE)



im. level .25  
 em. level .5

1=year 150  
 2=year 300  
 3=year 460

## CHAPTER FOUR

I have chosen to ignore the effect of clan groups throughout most of the previous considerations because of the difficulties that ethnographers have found in obtaining invariant exogamous groups that are recognized by all informants. A statistical analysis of data obtained by Reichard (1928) is used here to show that it is very unlikely that such invariant groups in fact exist. Although this chapter differs from those preceding it in that its focus is on a specific ethnographic question, the results obtained here are important because they justify the neglect of the clan groups in the exchange model developed previously.

### 1. The Statistical Analysis of Clan Group Data

Clan groups are defined by the extension of kinship terminology from one clan to others considered to be related (i.e. within the same group) by virtue of historical or mythological ties (Reichard 1928). The extension of kinship is accompanied by the application of marriage prohibitions to the whole group. Recognition of relatedness varies from community to community, and from informant to informant, and for this reason a basic statistical analysis has been used by many ethnographers to establish relatively consistent clan groups (Reichard 1928, Aberle 1961). This analysis assumes that two clans can be considered to be in the same group if, firstly, a number of informants agree, and secondly, very few marriages are observed between members of the two clans. The motivation behind this viewpoint is that the lack of marriages reflects a true proscription.

Despite the fact that the groups obtained in this way are formed partially on the basis of marriage data, there appears to be no statistical support for the claim that they represent true exogamous units. An analysis

of the data obtained on five communities by Reichard (1928) shows that the marriage patterns do not deviate significantly from those expected with clan exogamy only. Since the groupings Reichard defined have been basic to subsequent research on the problem, this throws into question results obtained in further attempts to find invariant groups based on empirical marriage data.

Although the statistical analysis is itself highly technical, the reason why the ascertained clan groups give a non-significant result is straightforward. The largest clans within each community are invariably assigned to different groups because of the number of exchanges occurring between them. From a local viewpoint each clan group can then consist of at most one large clan associated with a number of minor clans. Since the minor clans are involved in so few marriages in any case, the observation that few or no marriages occur within the group is not statistically significant. Only when the data from various communities is combined will groups contain more than one large clan. Although the pattern of exclusion is then significant, the analysis is no longer valid. By collapsing across communities we would be assuming that certain large clans have no marriage exchanges between them because they are in the same group, when in fact the reason for exogamy is that the majority of the members are in separate communities.

The marriages ascertained by Reichard (1928) in each of the communities are given in terms of marriage type in Tables 4.1-4.5. Because of the references in Chapter Two, the marriage data for Ramah and Navajo Mountain is also given here (Tables 4.6 and 4.7). This data is left out of the analysis because the clan group question has not been as extensively investigated in these two communities.<sup>1</sup> The dark lines surrounding blocks

of clans in Tables 4.1-4.5 indicate the clan groups as determined by Reichard. In cases when the concensus amongst informants was sufficiently complete, clans have been placed in the same group despite the existence of marriages between their members. For the purposes of this analysis all such marriages have been considered as violations of the ascertained groupings except in the case of clan 13. This has been assigned a separate group because Reichard (1928:44) states that if clans 20 and 21 are "related to 13...the relationship is not exogamous."

The marriage tables have been analyzed using statistical methods suitable for categorical data of this nature. The marginal totals for marriages involving male and female members of each clan have been taken as fixed, and the probability that the observed distribution of marriage types is formed randomly with respect to clan affiliations then tested. The analysis is complicated by the necessity of considering either clan or clan group exogamy. In these cases, the cells corresponding to the exogamous units are structural zeros; there is (theoretically) zero probability of observing a marriage in a cell containing a structural zero. A table containing a pre-determined set of structural zeros is called a structural model. Special iterative techniques must be used to perform statistical tests on tables with structural zeros. The methods used here are described in Bishop et. al (1975).

Zelditch (1959) attempts a similar statistical analysis on the marriages at Ramah, except he merges male and female members of each clan. The result is that he is analyzing data having a form similar to that given in Table 4.7. This is equivalent to introducing a set of structural zeros everywhere below the main diagonal in a rectangular table and hence requires the special methods mentioned above. Since Zelditch does not

employ these methods, his results must be considered as meaningless.

Three structural models have been used in the analysis of Tables 4.1-4.5; (1) a model without any exogamy restrictions (i.e. no structural zeros), (2) a model with clan exogamy only (structural zeros in cells marking clan exogamy), and (3) a model with clan group exogamy (structural zeros in the indicated clan groups cells.) The significance of the difference between any two of the models can be determined by subtracting the  $\chi^2$  fit for each. The difference is also distributed as  $\chi^2$  with degrees of freedom being the difference between that in each of the models. If the difference in the fit between the two models is not significant, then the data does not support the inclusion of the structural zeros that are included in one model but not in the other. Since clan exogamy is known to exist, the data supports the inclusion of the clan groups only if the differences between models 2 and 3 are significant. The differences between models 1 and 2 are reported to illustrate the power of this statistical method to demonstrate a known prohibition.

The use of the statistical methods described here is only approximate because of the fact that a certain number of marriages exist internal to the clan groups, and one actually violates clan exogamy. These marriages have been removed from the tables when they conflict with the structural model under consideration. This should not have a great effect on the outcome of the tests since few marriages are involved.

Table 4.8 shows the Freeman-Tukey  $\chi^2$  and the likelihood ratio statistics, both distributed asymptotically as  $\chi^2$  with the appropriate degrees of freedom, for each of the three models applied to the data from the five communities. Except in the case of Chinlee, the difference between models 1 and 2 is significant for all communities; this indicates the



existence of clan exogamy. The anomalous result for Chinlee is probably due to the fact that very few marriages have been ascertained in that community. The difference between models 2 and 3 (clan group exogamy) is not significant in any of the communities. This confirms that the data does not support the existence of Reichard's exogamous clan groups. While it may be possible to re-group the data in some manner which produces statistically significant exogamous groups, this strategy would be invalid since it would totally ignore the statements of informants.

The results obtained here suggest that the clan groups that are recognized in any community will depend on local clan distributions; the largest clans will always be placed into separate groups. Any prohibitions which are extended from one clan to the whole group will have at most a minor effect on the marriage patterns because of this. Even this effect will not be present if the recognized groups can transform to meet changing social situations within the community. Since such transformations apparently do take place between localities, there is no reason to think that groups should be invariant within a community; the existence of such local transformations has also been suggested by Aberle (1961). Since the clan groups do not statistically alter the pattern of marriage exchange, it is justified to have ignored their effects in an exchange model. Recalling the relationship between kinship and immigration described in Chapter Two, and the fact that minor clans usually appear as a result of inter-community marriage, we may speculate that the clan group is important in providing kinship relationships between communities which are otherwise heterogeneous in terms of clan affiliations. The possible significance of such kinship relationships in the pattern of inter-community marriage is discussed in Appendix IV. The flexibility of clan group

relations may be an important tool for the extension of kinship ties determining resource access for the members of the minor, immigrant clans.

## 2. Conclusions

Statistical analysis of Reichard's data gives no support for the existence of the clan groups which she described. Clan groups appear to be determined by an association between at most one locally major clan, and a number of minor clans. Such groups have no statistical effect on the pattern of marriage exchange, but may be important in providing kinship ties between communities.

## Notes to Chapter Four

1. Shepardson and Hammond (1970) did attempt to determine clan groups in the Navajo Mountain community, but because of inconsistencies they eventually divided relationships into those that are close, implying exogamy, and those more distant or "friendly" with inter-marriage allowed.

TABLE 4.1 MARRIAGE TYPES AND CLAN GROUPS AT KEAM'S CANYON:1925

	1	2	3	4	9	10	11	14	15	16	17	20	21	22	24	29	35	32	33	38	36	
1									1				3									3
2													1	1								
3																						1
4																						
6															1							
9									1		1							1				1
10													1		3		1			1		3
11											3		2		4		2			3		3
14	1							1			1				4	1	2	2		1	2	1
15																		1				
16	1												4				8	2		2		4
17											1		2				2			1	1	
20	2	1	3			2		3	2		5	4			11		8	5	1	3		8
22				2		1	1	1			5	5	5				2	7	2		1	3
24															2							1
25											1		1				1	1			1	1
29						1		2		1		6			5				1		1	
30															1							
35				1											1							1
32									1		1											
33	1								1		1						2					1
38									2		1	1					2					4
36	1		1					2	1	3	1	3			4	1	1		2			3
51a																					1	3

source: Reichard (1928)

TABLE 4.2 MARRIAGE TYPES AND CLAN GROUPS AT GANADO: 1925

	1	3	6	10	15	17	19	20	22	25	29	30	32	33	38	36
1												2				
3														1		
6				2					1							
10	2	1						1	2		3			1	1	1
14											2					
15												1				
17	1			2				1		3	5		2		1	4
20	1				5											
22	1			3		1				3						2
25					1				1						1	
29			1	3		2			6				1			
32									2							
33	1			3		2		1		1						
38		1		3		6			6							4
36			1	1		1		1	2						2	

source: Reichard (1928)

TABLE 4.3 MARRIAGE TYPES AND CLAN GROUPS AT CHINLEE: 1925

	9	10	17	24	29	38	36
3						1	
9							
10			1				
12				3			
14	1					1	
17	1					3	1
19							
20							1
22				1		1	
29	2	1			1	1	1
32							
34		1				1	
36						1	
40				1			

source: Reichard (1928)

note: males shown along vertical axis

TABLE 4.4 MARRIAGE TYPES AND CLAN GROUPS

AT LUKACHUKAI: 1925

	1	2	3	4	0	8	9	10	12	14	15	16	18	19	20	22	24	25	29	30	36	32	33	30	41
1																									
2																									
3																									
4																									
0																									
8																									
9																									
10																									
12																									
14																									
15																									
16																									
17																									
19																									
20																									
22																									
24																									
25																									
29																									
30																									
36																									
32																									
33																									
37																									

source: Reichard (1928)

note: males shown along vertical axis

TABLE 4.5 MARRIAGE TYPES AND CLAN GROUPS

AT SHIPROCK: 1925

	1	2	0	7	8	9	12	14	16	17	18	19	20	21	22	24	25	28	29	30	35	32	36	52
1																								
2																								
0																								
7																								
8																								
9																								
12																								
14																								
16																								
17																								
18																								
19																								
20																								
21																								
22																								
24																								
25																								
28																								
29																								
30																								
35																								
32																								
33																								
34																								
36																								
52																								

source: Reichard (1928)

TABLE 4.6 MARRIAGE TYPES AT NAVAJO MOUNTAIN, 1961

	Anglo	Apache	Ashihii	Ashihii (Paiute)	Bit'ahnii	Dibé lizhinií	Hashk'qq hadzrahó	Honagháahnii	Hopi	Kiyaa'aanii	Lók'aa' dine'é	Má'ii deeshgiizhnii	Mexican	Naakaii dine'é	Paiute	Shash dine'é	Tábqghá	Táchiinii	To'neeszahnii	Tl'áashch'ií	Tl'izi lani	Tó díchilinií	Tsi'naajinii	Ute Táchiinii	Yé'ii dine'é
Anglo																									
Apache																									
Ashihii			2		1	6	4			1	2	10	11	1	22	25	2	1							
Ashihii (Paiute)			15			6	11				5	1	8		11	15	1								
Bit'ahnii					1												3	3			8	10			
Dibé lizhinií																									
Hashk'qq hadzrahó																									
Honagháahnii								2														2	1		
Hopi																									
Kiyaa'aanii									1													2	3		
Lók'aa' dine'é																	5	5			3	7			
Má'ii deeshgiizhnii																									2
Mexican																									
Naakaii dine'é																3									
Paiute																									
Shash dine'é																									
Tábqghá																						1	10	9	
Táchiinii																							9	18	2
To'neeszahnii																									
Tl'áashch'ií																									
Tl'izi lani																									3E
Tó díchilinií																									1
Tsi'naajinii																									
Ute Táchiinii																									
Yé'ii dine'é																									

Ashihii=32

Dibe lizhini=34

Kiyaa'aannii=22

Naakaii dine'e=25

Tachi'nii=20

Tl'izi lani=14

Ute Tachii'nii=20

Ashihii (Paiute)=32

Hashk'qq had.=6

Lok'aa dine'e=8

Shash dine'e=51a

Taneeszahnii=1

To dichilinií=29

Ye'ii dine'e=20c

Bit'ahnii=9

Honaghaahnii=3

Ma'ii dees.=33

Tabaaha=36

Tl'aashch'i=16

Tsi'naajinii=17

\* no information available for each sex separately

source: Shepardson and Hammond (1970)

TABLE 4.7 MARRIAGE TYPES AT RAMAH\*: 1964

	37	29	35	51a	18	1	27	34	22	43	32	36	17	20	16	24	19	40
37		2	21	26	12	14	7		2	5	4	1		2				1
29	14		1	13	11	9	6		1	7	1				1	1		
35	14	8		2	4	12	3	2	1	10		2	2	2	2		1	1
51a	10	13	6	1	9	3	1		6		1							1
18	15	8	3	8	1	1			2	1	2	1		1		2		
1	5	5	7	6	8	1			2	2								
27	4	1	2	1	2				1									
34	1	1				1												
22	3	1	1															
43	1	1																
32					2													
36				2	1													
17	2																	
20				1		1												
25											1							
39						1												

\* estimated from fertile matings: excludes 80 matings where one partner was non-Navajo or one clan was unknown.

source: field data of Dr. K. Morgan

note: males along vertical axis

TABLE 4.8 STATISTICAL ANALYSIS OF CLAN GROUP DATA

Community	Model 1	Model 2	Model 3	Model 1-2	Model 2-3
Shiprock	FT=392.7	FT=324.3	FT=304.4	FT=68.4**	FT=19.9
	LR=552.6	LR=490.5	LR=451.6	LR=62.1**	LR=38.9
	DF=650	DF=627	DF=574	DF=23	DF=53
Lukachukai	FT=324.7	FT=281.9	FT=269.3	FT=42.6**	FT=12.7
	LR=469.4	LR=124.9	LR=400.8	LR=44.6**	LR=24.1
	DF=576	DF=553	DF=401	DF=23	DF=59
Kearney's Canyon	FT=286.2	FT=232.3	FT=226.9	FT=53.9**	FT=5.31
	LR=384.9	LR=333.6	LR=174.7	LR=24.3**	LR=8.5
	DF=460	DF=440	DF=401	DF=20	DF=39
Ganado	FT=148.1	FT=126.7	FT=123.7	FT=21.3*	FT=3.1
	LR=207.9	LR=183.1	LR=174.7	LR=24.8**	LR=8.5
	DF=210	DF=196	DF=276	DF=14	DF=20
Chinlee	FT=35.5	FT=33	FT=29.2	FT=2.5	FT=3.7
	LR=61	LR=55.9	LR=45.5	LR=5.1	LR=10.5
	DF=78	DF=73	DF=59	DF=5	DF=14

FT=Freeman-Tukey

LR=Likelihood ratio

DF=Degrees of freedom

\*\*prob. less than .05

\* prob. less than .1

all other values non-significant

## CHAPTER FIVE

In the 1969 preface to The Elementary Structures of Kinship,

Levi-Strauss writes that:

....in 1957-8 I contemplated approaching the study of complex kinship structures in a second volume to which several allusions have been made but which doubtless I shall never write. I should therefore explain why I have abandoned this project. While still quite convinced that it will not be possible to generalize unless the Crow-Omaha systems are taken into consideration, I have come to see, more and more, that their analysis raises tremendous difficulties which are the province, not of the social anthropologist, but of the mathematician. (Levi-Strauss 1969:xxxvi)

But Levi-Strauss' inability to analyze Crow-Omaha exchange arises, not from the limitations of social anthropology, but from his failure to go beyond the immediate demographic problems that such systems raise to the consideration of the structural effects of the constraints under which they must operate.

I have shown that any system of Crow-Omaha exchange practiced in a finite population has a tendency to converge towards a minimal structure with mechanical properties. While there is no reason to suppose that this tendency will be consciously recognized, it is possible that the people who practice a particular form of Crow-Omaha exchange do understand the properties of the minimal structure which preserves its operation. For instance, certain Navajo informants claim that marriage into the clan of one of the grandfathers is an ideal preference; other informants apparently deny that this is the case (Aberle 1961; Witherspoon 1975).<sup>1</sup> But regardless of the statements of informants, the fact that this pattern is determined by the minimal structure of exchange assures that it will be a dominant social form. The Navajo indeed have a statistical preference for marriage into these clans. By retreating from empirical problems of



social organization Levi-Strauss appears to be adopting the view that it is the ideological relationships which are determinant. This is against both the spirit of his earlier work, and the results obtained here, showing that a social system can have properties that are the consequence of its logic and operation, but not inherent in its ideological conception.

Social organization extends beyond ideology in that it provides solutions to problems of production and reproduction faced by all societies. Since the possible solutions are empirically constrained by existing demographic and subsistence conditions it is inappropriate to separate social relations from these factors. Furthermore, no form of social organization provides a perfect solution to these problems but actually leads to a set of new conditions which require further adjustment, thus producing a social dynamic. By analyzing the reproduction of clan affiliations, I have been able to show, using this framework, that demographic conditions enter dynamically into the realization of Crow-Omaha exchange and induce social patterns not apparent in the ideology.

This solution to the Crow-Omaha problem suggests a different future for kinship studies than that envisioned by Levi-Strauss. The model developed here provides a unifying link to principles which underlie the maintenance of social relations in a much broader range of societies than those of the Crow-Omaha type. In all societies in which kinship serves to define the relations of production, demographic variation is an important consideration in understanding the reproduction of the ties of alliance and consanguinity which are necessary to maintain subsistence patterns. In other societies, demography enters into the reproduction of class relationships. For instance, to understand the history of the slave mode of production, it is important to have an analysis of the effect the sexually imbalanced demographic structure of the slave population has on its

reproduction (Anderson 1974). Such an analysis does not imply a demographic determinism because it recognizes that social relations interact with demographic variables in structuring the population of interest. In this sense, the demographic reproduction of classes also enters into the analysis of capitalist relations of production (Marx 1967). Thus, by founding the model of Crow-Omaha exchange developed here in the question of the reproduction of clan affiliation, a link between the analysis of kinship-based and class societies has been revealed. Knowledge of the demographic structure which underlies kinship-based societies may be particularly important in understanding the impact of colonialism, and the pattern of imposition of capitalist relations of production.<sup>2</sup>

This wider theoretical framework, dealing with the demographic reproduction of social relationships, has also been recognized in some studies of elementary exchange. Several of these deserve mention here. The investigation of bilateral cross-cousin marriage undertaken by Kunstadtler et. al. (1963), showing that variation in the degree to which positive marriage rules are actually followed in different societies is influenced by demographic conditions, is a classic example of the use of simulation techniques in the study of social organization. Yennogan (1968, 1972) has used analytic methods to demonstrate that demographic factors limiting the number of ideal marriage types that can be formed in certain Australian section systems are important in explaining historical changes in social organization under colonial impact and population decline.<sup>3</sup> Similarly, knowledge of the recent pattern of population expansion, combined with an economic analysis, can be used to explain the revival and intensification of traditional forms of exchange and related ceremonies in some Australian societies that could not maintain their complex section systems with a restricted group size (Godelier 1975). Insofar as the

actual pattern of exchange and resulting kinship relations serve to integrate different local groups into a subsistence pattern, any demographic modification of the exchange system will have importance to an economic analysis.

Also related to the demographic model presented here is Friedman's (1975) discussion of clan organization under generalized exchange. Friedman's model refers to Kachin social organization, the general features of which are widely known as a result of the earlier analyses of Levi-Strauss (1969) and Leach (1961, 1964). Friedman has shown that the differences between the form of clan organization in Kachin society and those of neighbouring tribes is related to demographic variation, and his results suggest certain differences between clan fissioning under generalized and Crow-Omaha exchange. The Kachin have an expanding population and territorial base which results in the continual fragmentation of clans through emigration. Kinship ties between related lineages are maintained by making individuals originally from the same clan into preferred marriage partners after emigration. Amongst the neighbouring Chin and Naga, who have exchange rules similar to the Kachin but restricted emigration as a result of a greater population density, extended lineages and clan segments are built up within each community. Little clan fissioning is observed because clan solidarity is the basis for obtaining access to land within the community. The simulation results obtained earlier suggest that with a reasonably large community there will be no problem in maintaining a system of elementary exchange under these circumstances. Under Crow-Omaha exchange, demographic constraints acting in a closed community would lead to the opposite effect, namely the necessity of clan fissioning. On the other hand, the impossibility of a continuing alliance relationship between

lineage segments might encourage the maintenance of clan unity after migration as one way of providing permanent relationships between communities in a Crow-Omaha society. Further investigation of the variation in clan organization expected as the result of the interaction of demography with differing exchange structures might prove fruitful in the light of these results.

Several other problems deserving investigation are suggested by the model developed here and the other other studies referred to. Two problems may be particularly important within the context of Navajo social organization. Following Kunstadtler et. al. (1963), it would be possible to use the simulation model to investigate the degree to which the minimal exchange structure (i.e. marriage into the grandfather's clan) will statistically dominate the marriage patterns under various demographic conditions. By simulating another form of migration, independent of exchange factors, the degree to which community clan distributions and the tendency towards increasing skewness and clan numbers with population growth are dependent on the specific form of Navajo migration could be determined. In a more general context, it would be of interest to examine how imbalances in the sex-ratio and offspring number within a lineage or clan effect exchange strategies in the face of the necessity of maintaining a core labour supply for subsistence activities. Ballanoff (1973) has investigated some of the effects of sexual imbalances on clan survival. Such demographic imbalances may have important economic consequences, particularly in band societies where the size of each local group is very small.

Studies considering the demographic reproduction of social relations under various forms of exchange, and the theoretical problems they generate indicate that many important questions in this area await further research. Levi-Strauss' retreat from these problems must be

vigorously rejected to further our understanding of social organization. If, as Levi-Strauss believes, the solution to the Crow-Omaha problem contains the key to future studies of kinship-based societies, it is because the inadequacy of the methods he has recently advocated becomes most apparent in the analysis of the Crow-Omaha systems. However, a note of caution must be introduced into the solution proposed here: it cannot be considered as complete until the demographic theory is integrated with an understanding of the role of clan organization in determining relations of production. This is especially true in cases where clan hierarchization exists as a result of differential land-holdings. In such societies economic factors may deviate the exchange system away from the pure form of Crow-Omaha exchange defined by Levi-Strauss and illustrated here by the Navajo system. An analysis of the effect of such deviations is an essential prerequisite to an understanding of the demographic reproduction of these systems.

#### Notes to Chapter Five

1. Four original clans are also referred to in Navajo origin myths (Wheelwright 1949). The analysis of these myths might benefit from the understanding of Navajo exchange presented here but this is a topic beyond the scope of this thesis.
2. This is certainly true in the case of Navajo social organization. The Navajo population is sufficiently large that it serves as an important source of migrant labour for railway and resource development activity in the Southwest. According to Kelly (1968), the U.S. Government halted reservation expansion in the 1920's as a result of lobbying from development interests, creating a tremendous pressure on the subsistence base due to the growing population. Aberle (1966) has shown that the federal stock control problem established in the 1930's was applied in such a manner that the control of the traditional economy by large stock-owners was accentuated. The herds of smaller owners were reduced below subsistence levels, and many of these individuals were forced into accepting wage-labour employment. At the same time, traditional resources remained a large part of total subsistence, thus assuring the reproduction of the seasonal labour force with minimal wages. Since 1940 the stock levels on the reservation have been held nearly constant, as has the number of individuals who own a subsistence herd, while the population has grown

greatly. This has clearly had a major effect on Navajo social organization, but an adequate analysis has not yet appeared.

3. Yennogan's analysis is not a stochastic model and does not actually take account of the effect of demographic variation.

## APPENDIX I

Most aspects of the simulation program used in Chapter Three have been described by Morgan (1973b). This appendix justifies their use in a model of Navajo exchange.

Fertility and mortality schedules appear in Fig A1.1. The intrinsic rate of growth under these demographic conditions is 0.5%, considerably less than the greater than 2% growth estimated for the Navajo population between the years 1870 and 1952 (Johnston 1966). The reason for using a lower growth parameter in the simulation is that a maximum population limit has been established to avoid problems of computer costs and storage capacity. Because of the way in which the initial population is constructed, growth occurs at the beginning of a run even under level 2 clan rules. This artificial expansion must be restricted at this point so that the population does not reach the maximum allowed immediately. Although stabilization could occur with fewer marriages under a higher growth rate, the concern here is primarily with the proportion of the population which is excluded from marriage. This is a function of the variance in family size, and not directly related to the overall growth rate. However, it is usually assumed that human family sizes follow a negative binomial distribution, and if this is the case the variance will increase with the growth parameter (cf. Keyfits 1968). The parameters used here will thus underestimate the effect of the true family variance.

The potential for reproduction begins at age fifteen for either sex in the simulated population. Females are subject to a fertility schedule which declines to zero by age forty-nine, and the oldest individual in the population is eighty-five. Demographic schedules are applied in a

"yearly" cycle, as is the marriage subroutine described next.

The program is designed to maximize the total number of marriages formed subject only to the effects of the exchange rules and a correlation between the ages of marriage partners, and for this reason the marriage subroutine is not intended to be socially realistic. Individuals are first matched in the ten to fourteen years age range, despite the fact that fertility does not begin until age fifteen. Anyone who remains unmatched in a specific year is returned to the next year's marriage pool. An individual who is still unmatched at age fifteen is married into the over fifteen age category if this is possible. Separation of the two marriage pools assures a correlation between the ages of marriage partners, but does not exclude anyone from marrying solely as a consequence of this factor. Immigrants enter the population at age fourteen, allowing one year to marry into the below fifteen age category.

The model neglects two factors that are important in Navajo marriage: divorce and polygamy. The inclusion of either factor should not affect the qualitative nature of the results. Divorce allows more people to marry over a given time period without increasing the total number of individuals that can be married at any specific moment. Polygamy is a significant factor since it increases the constraints on men while weakening those on women. Aberle (1961:189) estimates that between 5 and 10% of marriages may have been polygamous in the 1930's. A complete model of the strategies involved in marriage and exchange must ultimately take account of both factors. However, it seems appropriate to ignore their effects in the determination of the basic properties of the exchange system.

The maximization of marriage potential and the conservative



choice of demographic schedules should assure that the effects of the marriage constraints are less in the model than in the real population. Initial conditions are also chosen to be conservative. The founding population for each run consists of individuals of age fifteen, and has a sex-ratio of 1/2. A maximum number of marriages is formed before the simulation is started. The initialization of exchange in the founding era of a real community can be thought of as entering somewhere along the path of a simulation run since the initial conditions employed in the model will not pertain in practice. The rapidity with which the effects of the exchange convergence appear under this ideal initialization provides assurance that the phenomena discussed have a social reality.

FIG A1.1 DEMOGRAPHIC SCHEDULES USED IN THE SIMULATION

AGE-SPECIFIC PROBS. OF DEATH FOR MALES		(AGES 0-MAXAGE YEARS)	
G.C377	0.0012	G.C012	0.0002
0.C002	0.0002	0.C002	0.0003
G.C004	0.0004	G.C004	0.0005
0.C007	0.0007	0.C007	0.0009
G.C015	0.0015	0.C015	0.0026
0.C046	0.0046	0.C046	0.0076
G.C119	0.0119	G.C119	0.0193
0.C350	0.0350	0.C350	0.0672
G.1538	0.1538	G.1538	0.1538

AGE-SPECIFIC PROBS. OF DEATH FOR FEMALES		(AGES 0-MAXAGE YEARS)	
0.0332	G.C012	0.0012	0.0002
0.0001	0.C001	0.0001	0.0002
G.C003	0.0003	0.C003	0.0004
0.C005	0.0005	G.C005	0.0006
0.0009	0.C009	0.C009	0.0015
G.C024	0.0024	0.C024	0.0036
0.C062	0.0062	0.C062	0.0115
0.0238	0.0238	0.0238	0.0496
G.1362	0.1362	G.1362	0.1362

AGE-SPECIFIC FERT. SCHED. FOR MARRIED FEMALES		(AGES YNGF-OLDF YEARS)	
G.0436	0.0436	G.0436	0.1017
0.1356	0.1356	0.1356	0.1066
0.0678	0.0678	0.0678	0.0242
G.0048	0.0048	G.0048	0.0048

## APPENDIX II

The ethnographic data presented in Chapter Two shows that prior kinship ties are important in inter-community marriages, and the analysis of clan groups given in Chapter Four demonstrates how such relationships could be maintained fictitiously even in the absence of a true genealogical connection. Recent evidence suggests that these ties function in the ideology of inter-community alliance, a viewpoint which derives from Witherspoon's (1975) account of Navajo social organization.

The Navajo view the social interactions defined by kinship in terms of the concept of k'e. According to Witherspoon (1975:120-121) k'e "means 'love', 'cooperation', and all the positive aspects of intense and diffuse solidarity." Kinship terms are referred to as k'e da'ahiddii'-ninii, translated as "the terms we use to address each other according to 'k'e'" (ibid:121). Except in special ceremonial contexts, kinship terms always replace the use of personal names in Navajo society. Similarly, affinal terminology is considered to be insulting and vulgar, and is used only in reference.<sup>1</sup> As a result, consanguinal terminology is always employed when addressing affinal relatives. Actual kinship ties often provide a basis for these terms, but if no real relationship exists, fictitious terms are used. For instance, the spouse of a sibling is usually addressed with cross- or parallel-cousin terminology (Landar 1962). Cross-cousins are often said to make ideal sweethearts or marriage partners (Witherspoon 1975).

These ethnographic facts appear to indicate that marriage is conceptualized as ideally following kinship lines. Co-operation between affinal relatives, which includes access to resource usage and participation in mutual production activities, also appears to fall into the

category of k'e. In the formation of inter-community alliance, where possibly no previous ties of kinship have existed, there is a particularly noticeable attempt to establish a prior ideology of k'e relationships. This is expressed in the performance of the Enemyway, which is, like most Navajo ceremonies, a curing rite.

Although the Enemyway is a minor religious ceremony, it has become famous as a tourist attraction in the Southwest under the name of the "squaw-dance." The social significance of the Enemyway has been recognized by many anthropologists because of the number of marriages formed during its performance (cf. Kluckhohn and Leighton 1974). The discussion given here follows Haile (1938) and Witherspoon (1975).

The Enemyway is a curing ceremony for patients fallen ill from contact with non-Navajo. Any illness falling into this category is said to arise from the spirits of the ani'i, or literally, the enemy. According to Witherspoon (1975), the concept of the ana'i is opposed to that of the dine, or the people (i.e. any member of a Navajo clan). Therefore, ana'i is used to refer to any non-Navajo. Ideally, the relationship between dine is one of k'e or kinship. When two Navajo groups are in conflict they no longer relate in terms of kinship, but become ana'i to each other, and "at the conclusion of any war, fighting, or confrontation, one often hears the phrase k'e nahasdii which means that conditions have returned to k'e" (Witherspoon 1975:120). The Enemyway expresses this transformation symbolically.

Extensive planning and financing are required for the holding of the ceremony since over a hundred people participate in the performance:

From the initial planning to completion, the ritual requires around two weeks, with the last three days containing the major aspects of the ritual. By assuming that the ritual is performed an average of five times

each summer in each community, and with approximately one hundred Navajo communities, it is likely that the ritual occurs five hundred times each summer. An average of two thousand dollars is spent or exchanged in the performance of each ritual, and so it is likely that a million dollars is spent yearly by Navajo in the performance of the Enemyway. (Witherspoon 1975:58).

In the initial planning stages, the patient's kinspeople choose an individual, usually from another community, with whom they wish to establish new or stronger alliance ties. This individual is presented with a rattlestick, representing the dine and forming one of the two main symbols of the ceremony; the other is the symbol of the ana'i, a scalp.

After accepting the stick, the stick-receiver chooses an unmarried woman from amongst his own kin to lead his kinship group during the performance. The ceremony emphasizes an initial opposition between the two participating kinship groups, but culminates in the establishment of k'e relationships. The whole performance takes about three days, beginning in the stick-receiver's camp and ending with a curing in the patient's camp.

Gift exchanges are made in each camp. In the initial part of the ceremony, the patient's group distributes gifts to the stick-receiver's kin. Gifts received at this time must be redeemed in the patient's camp with others of equal value. The first exchange of gifts is preceded by a mock attack of one group against the other; the gift are said to be the booty of war. Their redemption is also preceded by a mock attack in which the roles of the two groups is reversed. After this the conclusion of peace is symbolized by a combined attack on the scalp (Haile 1938).

Gifts are also given by male dancers to their female partners in the dances that are held every night during the ceremony. Female dancers are all unmarried, and each chooses an eligible male from the

opposite kingroup as a partner (hence the name "squaw-dance"); they are encouraged in their choice by family members desiring a particular alliance. The conclusion of the ceremony is marked by the formation of a number of marriage engagements arranged by the families involved. This follows traditional Navajo patterns where the first marriage is controlled by the extended kinship group because of its economic significance. The brideprice is sufficiently high that it must be provided by the older, more established relatives of the groom, and both families have a vested interest in the economic relationships that arise from the alliance.

The Enemyway symbolizes the establishment of k'e relationships between two groups desiring more extensive alliance relationships, and usually residing in different communities. This suggests that kinship ties may be important in the ideology of intercommunity alliance. This would explain the empirical relationship of kinship and exchange that is observed in immigration, and also provide an interpretation of the role of the clan group in Navajo social organization. If this interpretation is correct, the function of the clan group is not so much to negatively exclude marriage, but rather to provide a justification in terms of kinship for particular positive marriage patterns. Further ethnographic investigation of the role of the clan group in intercommunity marriage is required, as is a more precise determination of the structure of the kinship groups participating in the Enemyway, before a complete understanding of the Navajo ideology of intercommunity alliance is possible.

#### Notes to Appendix II

1. An exception has been noted by Aberle: "Although immediate in-laws would not use affinal terms for address, people outside this circle might do so. Thus a Navaho may use an affinal term to address a clansman's spouse, or the spouse of someone born for (a child of) his clan" (1961:178).

### APPENDIX III

Several variants of Navajo kinship terminology are recorded in the ethnographic literature (Landar 1962). Some of this variation is undoubtedly due to regional or temporal changes, but a recent study by Witherspoon (1975) suggests that the most significant differences reflect distinct contexts of useage. Witherspoon attempts to apply his results to a functional model of Navajo marriage which is in fact contradicted by the data. Nevertheless, his basic analysis of kinship does clarify certain ethnographic problems including the question of admissability or inadmissability of cross-cousin marriage which was first raised by Reichard (1928).

Basic kinship terminology is Iroquoian as shown in Fig A3.1. In ego's generation bifurcate merging distinguishes cross- and parallel-cousins without regard to clan affiliations. Four categories of relationship are distinguished in the first ascending generation, and reciprocally in the second descending generation: Fa (merged with FaBr), FaSi, Mo (merged with MoSi), and MoBr. However, the term shibizhi complicates the situation. Normally, this is used to refer to FaSi, but several ethnographers have reported its extension to male relatives in the first ascending generation excluding ego's father (Landar 1962, Shepardson and Hammond 1970). This is indicated as optional terminology in Fig A3.1.

One curious feature of the Navajo terminology is the "born-between" phenomenon reversing useage between a nephew or niece and a younger maternal aunt or uncle. For instance, a male ego will address his younger maternal aunt as shima yazhi (instead of shima) and she will respond with shida (instead of shida'i). The reversal is extended to the next generation so that, in this example, ego's children are classified as cross-cousins by their great-aunt, while ego merges her children with the second

descending generation. Other terms used to distinguish relative age are given in Fig A3.1.

The explanation for several other variants also seems to be straightforward. For instance, shicho can be used to refer to a female in the second ascending generation, replacing shima sani, and can also be used reciprocally in the second descending generation. In the latter case, sitsoi is replaced either by shicheii or shicho depending on sex. Such variation is minor in the sense that no basic categorical differences are created as a result of its substitution.

Major variants merging across generations in related clans have also been reported (Landar 1962). A detailed ethnographic study by Witherspoon (1975) suggests that the generational merging terminology relates to a systematic alternative useage which can possibly be distinguished from the Iroquoian system by the social context of its useage, although the terms overlap. The contextual differences can best be illustrated through a specific example. A member of the Aschichi clan will identify his clan affiliation when meeting a stranger by stating: "Aschichi ei shima'adaat'e" ("Those of the Ashichi clan are related to me as my mother is.") Similarly the statement: "Tl'izi lani (father's clan) ei shizhe'e'adatte" identifies his relationship to the Tl'izi lani clan ("those of the Tl'izi lani clan are related to me as my father is.")<sup>1</sup> Such identifications, which extend to other clans, define categorical relationship between genealogically unrelated individuals, and in this situation the basic terminology may also provide a form of address. Thus, two men of the same clan having no close genealogical relationship may address each other as shima;<sup>2</sup> similarly an unrelated male in the father's clan is addressed as shizhe'e (Witherspoon 1975:43). In general, however, Iroquoian terminology appears



to be used within the range of usual social interaction, with the generational merging system employed only beyond this range. For instance, Landar (1962) indicates that the spouse of a sibling is usually addressed with an Iroquoian cousin term apparently even when a genealogical relationship does not exist.

Six generationally merged categories of kinship are recognized within the Navajo terminological system. Ego distinguishes: (1) members of his or her own clan; (2) his or her father's clan; (3) his or her maternal grandfather's clan; (4) his or her paternal grandfather's clan; (5) persons born for his or her clan; and (6) persons born for his or her father's clan. The Navajo say that a child is born for the father's clan; thus relationship (5) is the inverse of (2), and (6) refers to persons whose fathers are of the same clan. The complete terminology is given in Fig A3.2. Note that each of the terms are also used in the Iroquoian system of A3.2 but not in an exactly corresponding manner.

The most controversial aspect of the Navajo kinship is the question of the terms extended to ego's parents' cousins and their children. Shepardson and Hammond (1970), who have conducted an extensive investigation into this problem, record a variation in the use of Iroquoian and generational merging terminology (see Fig A3.3). They explain this as being due to the existence of complex relationships based on clan affiliations. For instance, the preferred term for members of the paternal grandfather's clan is said (p 233) to be shinali (based on their interpreter's explanation: "my father's father, shinali is a Tl'izi lani clansman; therefore all Tl'izi lani are shinali to me") but cross-cousin terms are expected to be used in ego's generation when the father of the person concerned is a member of ego's clan, thus providing a closer relationship.

This argument is unsatisfactory in the case of the variation reported by Shepardson and Hammond because it provides no explanation for the pattern of terms appearing as alternatives in each genealogical position. To continue with the previous example: if the father of the individual concerned was a member of ego's father clan, sibling terms would then be expected to be used because ego and this specific member of his grandfather's clan would also be born for the same clan. Yet sibling terms are not elicited as alternatives for this genealogical position. Since a similar argument can be advanced regarding the other alternatives indicated in Fig A3.3, it is clear that a different mechanism must determine the reported variation.

Separation of the generational merging and Iroquoian useages provides a solution to this problem. For example, consider members of the FaFa's and MoFa's clans. These individuals are related to ego within the context of the generational merging terminology as either shinali or shicheii (shicho if female). Alternatively they are assimilated as cross or parallel relatives in the theoretically correct manner for Iroquoian terminology. Overlaying Figs A3.1 and A3.2 shows that all the variation within Fig A3.3 can be explained as a result of the distinction between the two terminological systems. Table A3.1 gives the logic behind each of the reported alternatives. The fact that greatest stress in the terminological system occurs in the case of third-order relationships indicates that these relatives are at the limits of the usual social interactions which determine the Iroquoian useage.

One way of looking at the difference between generational merging and Iroquoian useage is to note that the former defines relationships in terms of marriage classes while the latter merges across these classes. It is interesting to note that the statistical preference for marriage

into the grandfather's clan corresponds to marriage into the generationally merged kinship categories of shinali and shicheii (shicho). Even though these terms may be applied within the Iroquoian system to individuals excluded from marriage by the clan proscriptions, the "born-between" phenomenon assures that all individuals of the same relative age as ego will be in an eligible marriage class. To see this consider a member of ego's own or father's clan, related genealogically to ego in the second generation, but of the same relative age as ego. This person is thus younger than ego's parents, and will be addressed in the Iroquoian system by cross- or parallel-cousin terms. In the generational merging terminology, the relationships within the father's or mother's clan take precedence over the more distant grandparental relationships and thus also imply cross- or parallel-cousin terminology. Therefore, from an empirical viewpoint requiring a correlation in age between marriage partners, the categories of shinali and shicheii (shicho) are exactly those relatives eligible for marriage.

Witherspoon (1975) uses the existence of the generational merging terminology to put forward a functional model of Navajo marriage based on sentiments assumed to be attached to specific kinship categories. For instance, he argues that the possibility of applying the term shima to all members of ego's own clan implies that such individuals are treated as a mother, and hence are ineligible for marriage. The other marriage prohibitions are explained similarly, and the Iroquoian system of terms is held to arise from further refinement of the basic generationally merged kinship categories. However, this theory is untenable since the Iroquoian terms merge across clan lines and create new categories each of which includes marriagable and unmarriagable individuals. Unless it was shown, by some

method as yet unknown, that the Iroquoian terms reflect false sentiment while the generational merging terms subsume true feelings, the functional model becomes hopelessly inadequate in this situation. The existence of marriage proscriptions cannot be used as the basis of such a distinction between the terminological categories for this would make the argument circular. Therefore, Witherspoon's theory of Navajo marriage must be rejected.

There is one further question which should be examined from the viewpoint of the kinship system. Reichard (1928:65-69) reported that marriage into the father's clan was preferred. While later ethnographers have elicited some statements from informants which seem to support Reichard's position, particularly regarding the possibility of cross-cousin marriage, they have also found that the system of clan prohibitions described in Chapter One is explicitly recognized at the same time (Aberle 1961, Witherspoon 1975).<sup>3</sup> The analysis of kinship presented here shows that no contradiction is involved. Since the Iroquoian terminology extends beyond the proscribed clan to other genealogical relatives, marriage between classificatory cousins is indeed possible and it is only the interpretation of the distance of the relationship mentioned by Reichard which is at issue. It seems apparent that any member of a proscribed clan is too "close" a relative to allow the possibility of marriage.

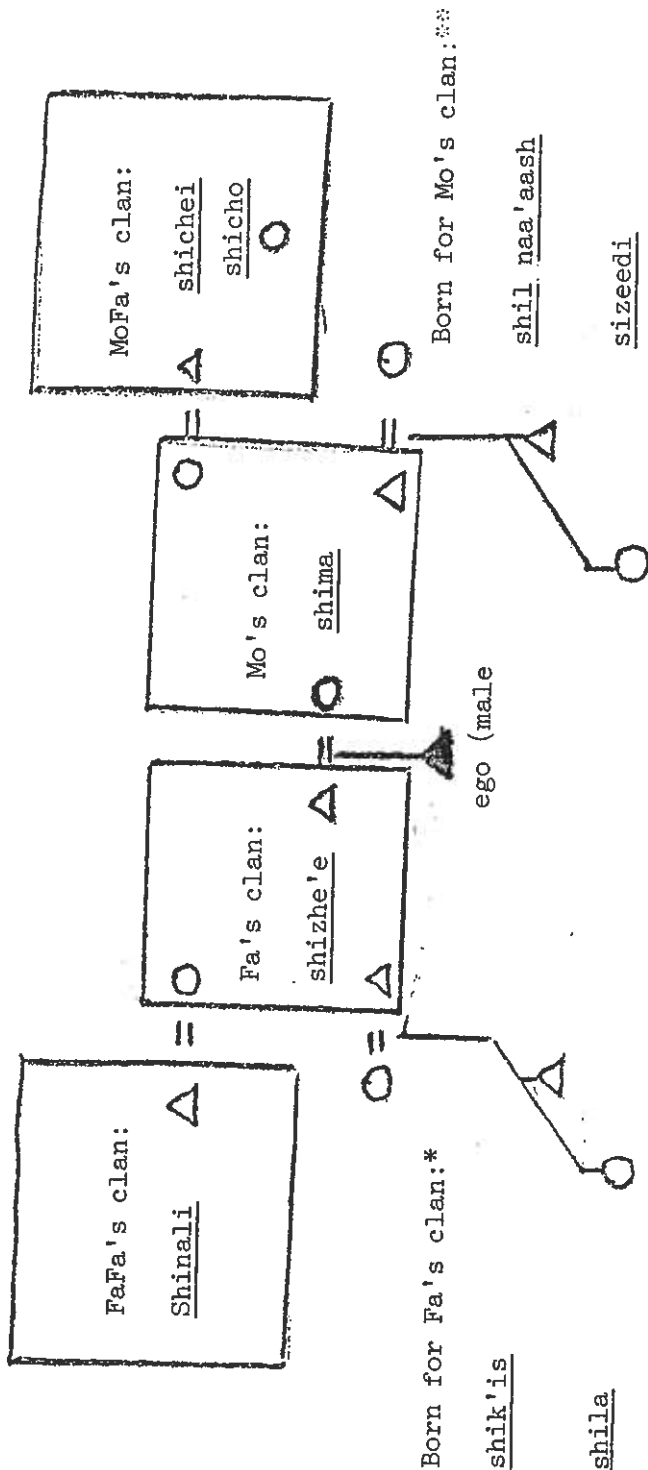
#### Notes to Appendix III

1. The examples are taken from Witherspoon (1975) but the translations have been changed to remove his functional bias. He translates "those of the Aschichi clan are my mother" etc.
2. It is probably more usual to make sexual distinctions while still merging across generations. See also Landar (1962).
3. The most prevalent of informant statements refer to cross-cousins, and it may have been these that led Reichard to the conclusion of a preference for marriage within the Fa's clan. Witherspoon (1975) notes that "Everyone has found extensive joking about sexual relationships with cross-cousins."

Navajo boys use the term "shizeedi" (cross-cousin of the opposite sex") as a term for lover or sweetheart. One of the Enemyway songs implies sexual relations between cross-cousins (p 46), and that "some of the people told me the Navajo consider their cross-cousins to be their sweethearts and ideal sexual partners" (p 127). Cross-cousins are distinguished from parallel cousins in regard to this informal sexual joking etc. Relationships between parallel cousins are much more formal. Aberle (1961) has interpreted these facts as evidence for a historical period when bilateral cross-cousin marriage was preferred. Witherspoon, on the other hand, believes that cross-cousin terms refer only to members of the Fa's clan and concludes that ego "may ignore the relationship of descent and see his father's clanswomen as ideal affinal relatives, or he may wish to emphasize the relationship of descent with his father's clan" (p 46), i.e. he can recognize or ignore the prohibition. It seems evident that the interpretation presented here is preferable to either of these.



FIG A3.2 GENERATIONAL MERGING KINSHIP TERMINOLOGY

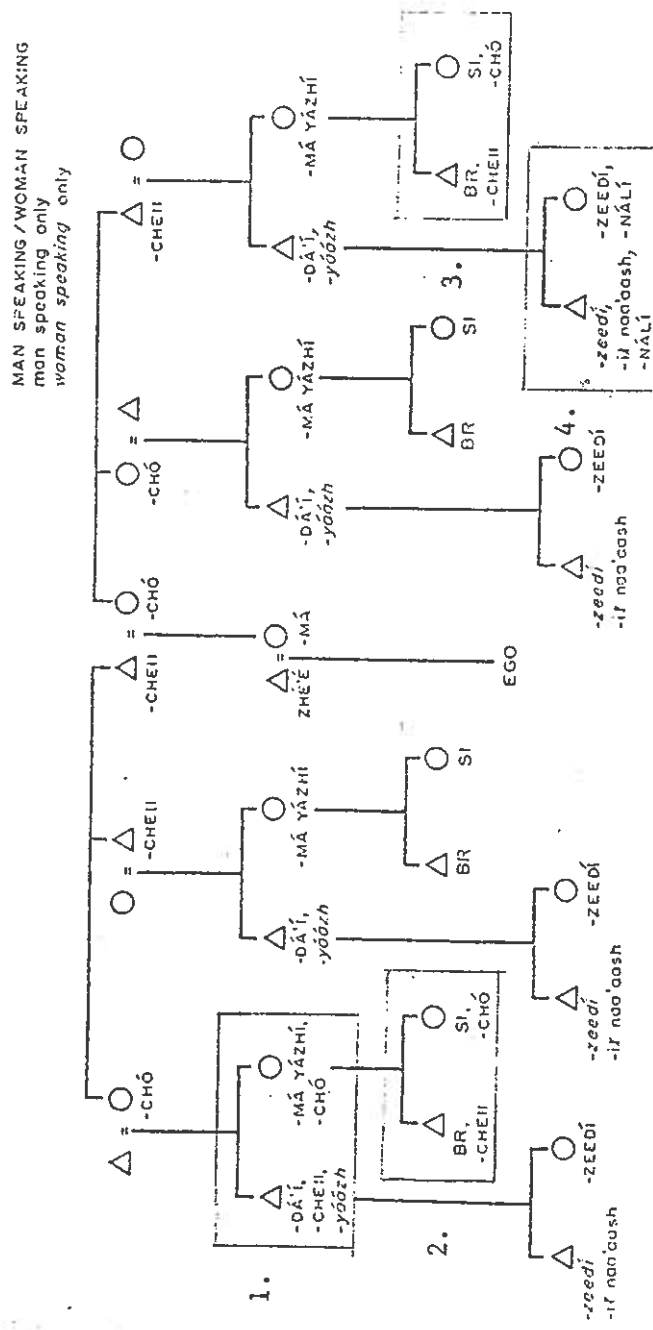


\* terms reversed for female ego

\*\*sizeedi is the only term used by a female ego; sha'lchini is another possibility for a male ego.

source: Witherspoon (1975)

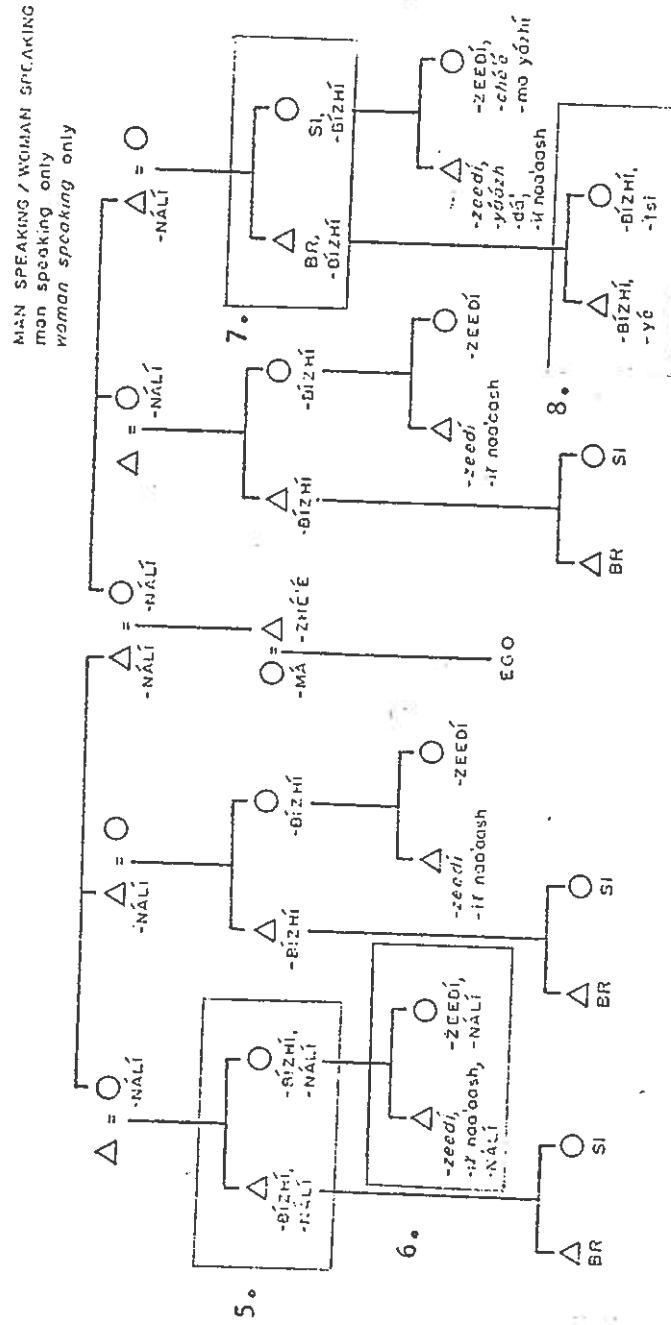
FIG A3.3a EXTENDED KINSHIP TERMINOLOGY: MATERNAL SIDE



source: Shepardson and Hammond (1970)



FIG A3.3b EXTENDED KINSHIP TERMINOLOGY: PATERNAL SIDE



source: Shepardson and Hammond (1970)

TABLE A3.1 EXPLANATION FOR THE KINSHIP VARIATION IN FIG 4.3

- 1.\* Either members of MoFa's clan, or maternal aunt or uncle.
2. Either members of MoFa's clan, or parallel cousins.
3. Ego is a member of their MoFa's clan so shicheii and shicho are used reciprocally. They are also related as parallel cousins.
4. Ego is a member of their FaFa's clan so shinali is used reciprocally. They are also related as cross-cousins.
5. Either members of FaFa's clan or paternal aunt or uncle.
6. Either members of FaFa's clan or cross-cousins.
7. Either born for Fa's clan or paternal aunt or uncle.
8. Not a variant, but confusing nevertheless. Ego's father is a member of FaFa's clan, and therefore is shinali. Thus ego is considered to be related paternally, one generation ascending.

\* numbers refer to FIG 4.3

#### APPENDIX IV

The purpose of this appendix is to discuss a developmental cycle model of Navajo corporate groups, widely accepted in the ethnographic literature but which fails to take account of exchange and alliance relationships. This failure will be shown to lead to mistaken conclusions about the nature of Navajo social organization.

As mentioned in Chapter Two, the Navajo corporate unit is a bilateral kinship group often called an outfit. Kluckhohn and Leighton originally defined the outfit as being composed of:

Two or more extended families, or one or more extended families linked with one or more independent families (who) may habitually pool their resources on some occasions--say, planting and harvesting, or the giving of any major ceremonial for an individual member (Kluckhohn and Leighton 1946:62).

An outfit has a leader, generally an older, wealthy male who controls the use of resources, the ownership of which is vested in the outfit. Livestock are owned individually, but established patterns of sharing their disposition exist internally to the group. Resource control is usually transferred from father to son or son-in-law. However, personal wealth is divided, often before death, between a wide range of relatives, some of whom may be outside of the outfit.

The outfit is a descriptive concept which has been integrated into a theoretical framework by Lamphere (1965) and Reynolds et. al. (1967) through consideration of a developmental cycle model of corporate group formation. This model has been either explicitly or implicitly accepted by most ethnographers, and is used to predict patterns of outfit growth and fragmentation.<sup>1</sup> Bilateral kinship ties between nuclear families are said to allow younger married couples the option of either associating

with the husband's or wife's family until they achieve economic self-sufficiency with "grandchildren participating in cooperative activities through their parents" (Reynolds et. al. 1967:197). The formation and fragmentation of the corporate groupings is thus assumed to take place within the developmental stages of family consolidation and dispersion identified in a general theoretical setting by Fortes (1958).

Implicit in this developmental cycle model is the assumption that exchange and alliance relationships are not a significant feature of Navajo social organization. The failure to account for these relationships has led to a mistaken interpretation of outfit fragmentation in the following way. Reynolds et. al. state that:

Two generations of sibling groups maintain occasionally cooperating ties under the leadership of a common older, biologically related male. Thus, the outfit is a product of the residence cycle and the rules for transmitting the control of resources, operating over three generations. (Reynolds et. al. 1967:197-8).

The three-generational lines of outfit fragmentation proposed by Reynolds et. al. are shown in Fig A4.1. If this pattern of fragmentation was basic to Navajo social organization it would have important social consequences since it implies a dispersion of corporate holdings over a number of generations. Aberle (1963), for instance, has concluded that no lines of wealth can be maintained in Navajo society because of the dispersion of herds bilaterally to a number of independent families. Reynolds et. al. (1967) attempt to confirm the validity of their model by describing how the empirical pattern of descent relations in outfits in the Ramah community conforms to the theoretical three-generational pattern.

This model assumes that new ties of kinship are formed by marriages external to the outfit as shown in Fig A4.1. A simple transformation of the exchange pattern, allowing an internal marriage, results in a com-

pletely different interpretation of the social formation (Fig A4.2). As a result of the renewed alliance within the outfit, internal patterns of kinship co-operation are reinforced, and there is no necessary dispersion of large estates. Furthermore, the two patterns indicated in Figs. A4.1 and A4.2 cannot be empirically distinguished on the basis of descent relationships. Because of the kinship ties created by the internal marriage, the outfit group in Fig A4.2 has the same empirical three-generational format as those in Fig A4.1 although its actual structure is quite different. Thus any study of Navajo corporate group formation must take account of the pattern of exchange and alliance.

Where details of the pattern of outfit formation and exchange are known, principally in the Ramah community, the question of alliance is clearly very complicated. Following Kluckhohn (1956) and Lamphere (1965), I identified in Chapter Two two original outfits to which members of the founding population were affiliated. However, it is not actually known if these groups were defined on the basis of co-operative ties. Subsequent outfits, of which seven existed in Ramah in the 1940's, were formed on the basis of alliance between members or descendants of each of the original groups. Because of this it cannot be certainly stated that the original groups were actually outfits, and in fact the subsequent pattern of alliance suggests that they may have more closely followed the structure of the kinship groups which emerge in the performance of the Enemyway and which have been discussed in Appendix II.

The two founding groups were formed around two leaders--Hastin Cojo and Many Beads--who were the dominant political and economic figures in Ramah during their lifetimes. Kinship ties to these men defined the membership for each group. Clan affiliations and some of the known

genealogical relationships between the basic founding members have been shown in Table 2.1. While the genealogical relationships show that each group is formed bilaterally, the indicated kinship or clan relationships between males are considered to have been the most important factor in their original formation. For instance, Lamphere has noted that:

Ties between women may have been important in a couple's decision to settle in Ramah. Both Solao and his wife and No Hat and his wife had genealogical or clan ties in the group. Loincloth (the brother of Many Beads) was married to the sister of the first wife of Many Beads, indicating that both had gealogical relatives already in Ramah. However, there is no case of a woman, on the basis of her kin affiliations, bringing into the community a husband who did not also have a kin or clan tie. A strong trend towards virilocal residence is partly a result of "men bringing in women"... (Lamphere, 1965:11, emphasis added).

Furthermore, later immigration (which consisted only of males until 1930) showed the importance of clan ties between men. This is most striking in the case of the Kiia'aanii clan which has had no female representatives in Ramah. Kluckhohn has noted:

Although this clan has never been one of the four or five most numerously represented at Ramah, the number of male "founders" (and "pre-founders" who have lived in this area) who had this affiliation is striking....At any rate membership in this clan surely appears to have been the principal nucleating force in the settlement. Indeed a surprisingly high proportion of men marrying into Ramah (from other Navajo groups) in the past thirty years have been from this clan (Kluckhohn, 1956:366).

In summary the organization of the two groups is based on kinship or clan ties between males, relationships between females being subsidiary. Adams (1971) has indicated that a similar pattern may have existed in the formation of the Shonto community. In the Ramah case the pattern had important consequences for subsequent exchange since each group contained women from at least two clans. If clan relationships between females had determined their formation (i.e. if they were matrilineages) then continued alliance

within the community would have been impossible because of the nature of the marriage rules.

Marriage alliances between the two groups existed prior to their release from Fort Sumner, and reciprocal exchanges continued at Ramah. For instance, four of Cojo's daughters married two of Many Beads' sons, and Cojo's fourth wife was a daughter of Many Beads. Numerous other examples of this alliance formation, extending over a number of generations, can be cited (Kluckhohn 1956). Certain of the basic alliances, illustrating the complexity of the pattern, are shown in Fig A4.3. The close relationship between the empirical alliance formation and the theoretical internal pattern shown in fig A4.2 suggests the possibility that we are dealing with one original outfit rather than two. Immigration was also integrated into this alliance formation through the genealogical and clan or clan-group ties existing between the immigrants and prior community members. Hence, Kluckhohn has noted that "much....immigration was simply an extension of relationship and established in the 'founding' period.... recurrent alliances between the Cojo and Many Beads outfits" (1956:368-9). He also indicates that this pattern continued until at least the 1930's.

By 1940, the Ramah community had expanded both in territory and in population (numbering over 480 persons at this date). Although it certainly necessitated the fragmentation of the outfit groupings, this appears to have occurred along different lines than that predicted by Reynolds et. al. (1967) with basic alliance relationships being maintained. A complete investigation of this question is beyond the scope of this appendix, and must be reserved for a later date. It should be noted, however, that continuous lines of wealth have been maintained in Ramah as a result of the core alliance formation partially detailed in Fig A4.3.

The theoretical and empirical discussion of alliance relationships in this appendix has revealed the inadequacy of the developmental cycle model as an explanation of Navajo social organization.

Notes to Appendix IV

1. Certain authorities have denied the validity of this model. Wither-  
spoon (1975) stresses the importance of corporate matrilineages but offers  
no proof of their existence. Lamphere (1970) has argued against her ear-  
lier model, suggesting that corporate groups are not important in Navajo  
social organization, and that fluctuating networks of kinship determine  
actual patterns of co-operation. Since she provides no analysis of the  
pattern of exchange which produces the distribution of kinship observed  
in Navajo society, her new model remains as inadequate as the old. This  
can be seen, for instance, in her two main conclusions regarding cere-  
monial co-operation, the specification of the two "rules" which determine  
kinship participation: "primary kin are preferred to secondary kin, and  
local to non-local kin" (197):56). It need hardly be stated that these  
"rules" are of such a general descriptive nature that they can be tauto-  
logically applied to almost any society.



FIG A4.1 PATTERN OF OUTFIT DIVISION IMPLIED IN THE DEVELOPMENTAL CYCLE MODEL

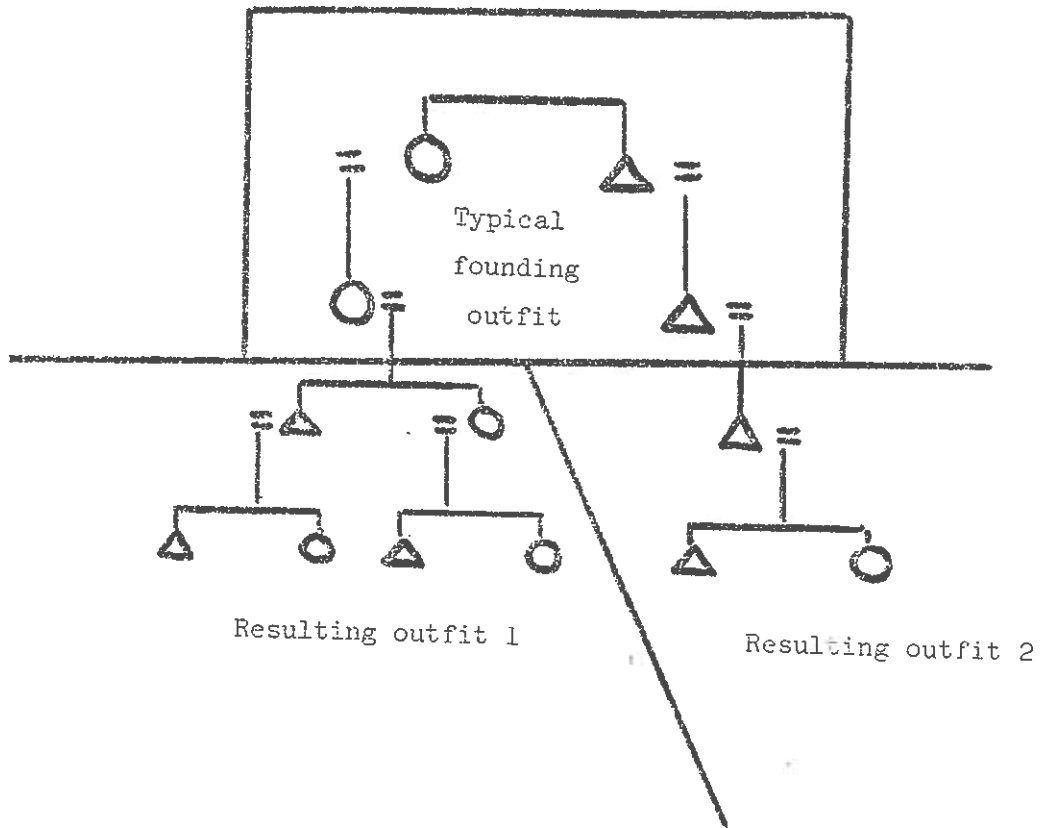


FIG A4.2 THE RESULT OF INTERNAL ALLIANCE

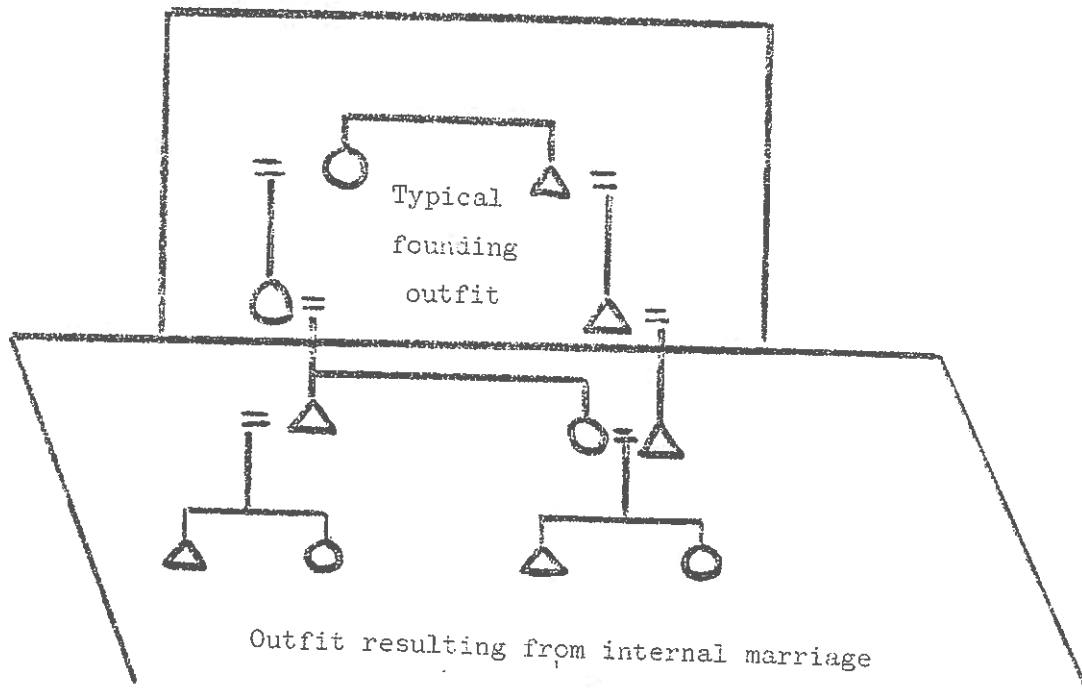
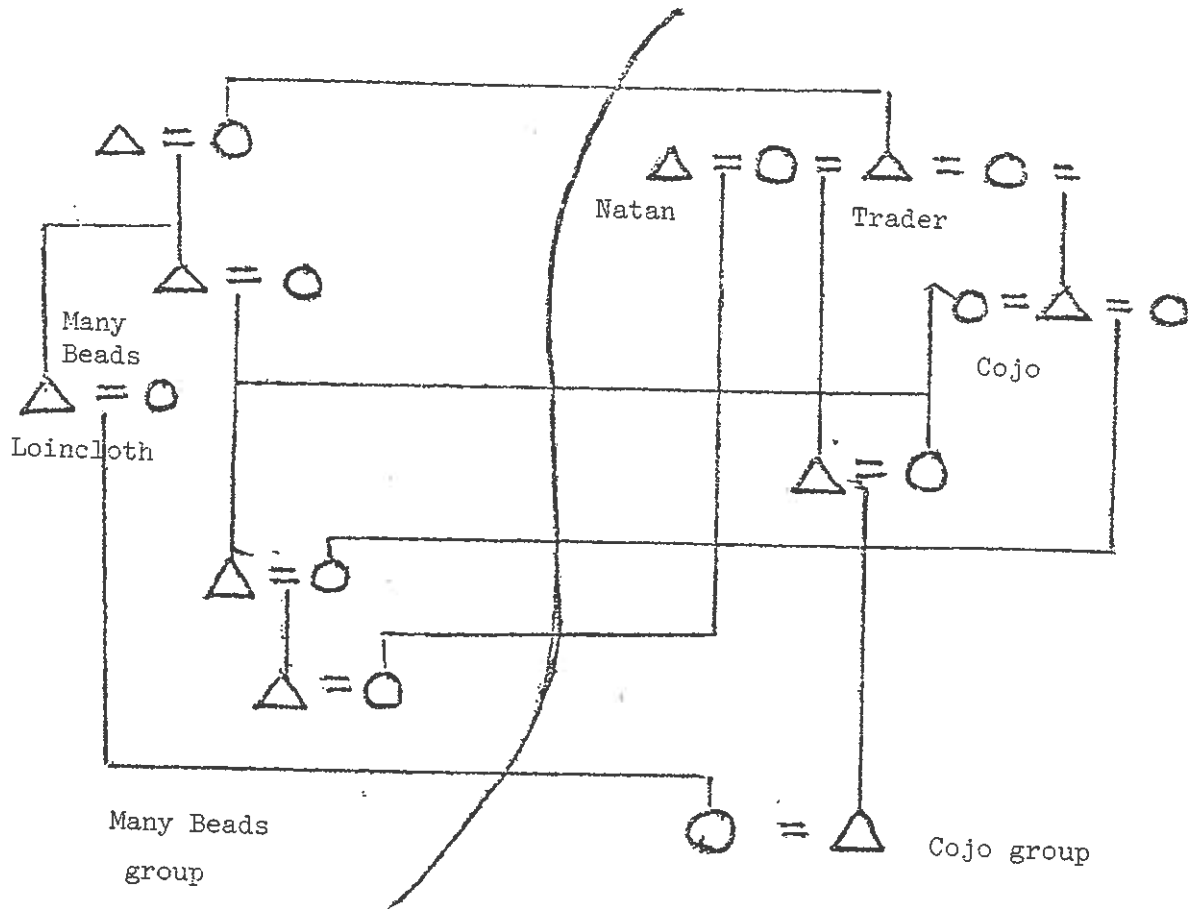


FIG A4.3 A PORTION OF THE RECIPROCAL ALLIANCE PATTERN IN RAMAH



BIBLIOGRAPHY

- ABERLE, DAVID  
 1961 Navajo IN Matrilineal Kinship (eds.) D. Schneider and K. Gough, Berkeley: Univ. of California Press.
- 1963 Some sources of flexibility in Navajo social organization  
 Southwest Journal of Anthropology 19:1
- 1966 The Peyote Religion Among the Navajo. Chicago: Aldine.
- ADAMS, W. Y.  
 1971 Navajo social organization. American Anthropologist 73:273
- ANDERSON, PERRY  
 1974 Passages from Antiquity to Feudalism. London: New Left Books.
- BALLANOFF, PAUL  
 1973 Structural statistics: models relating demography and social structure with applications to Apache and Hopi. Social Biology 20:421.
- BISHOP, Y, S. FIENBERG AND P. HOLLAND  
 1975 Discrete Multivariate Analysis: Theory and Practice. Cambridge: MIT Press.
- FORTES, MYER  
 1958 Introduction to The Developmental Cycle in Domestic Groups (ed.) J. R. Goody. Cambridge: Cambridge Univ. Press.
- FRIEDMAN, JONATHAN  
 1975 Tribes, states and transformations IN Marxist Analyses and Social Anthropology (ed.) Maurice Bloch. London: Malaby Press.
- GODELIER, MAURICE  
 1975 Modes of production, kinship, and demographic structures IN Marxist Analyses and Social Anthropology (ed.) Maurice Bloch. London: Malaby Press.
- HAILE, B.  
 1938 Origin Legend of the Navaho Enemy Way, Yale University Publications in Anthropology, #17, New Haven: Yale Univ. Press.
- JOHNSTON, D. F.  
 1966 An Analysis of Sources of Information on the Population of the Navaho. Smithsonian Institute, Bureau of American Ethnology, Bulletin 197, Washington.
- KELLY, L.C.  
 1968 The Navajo Indians and Federal Indian Policy, Tucson: Univ. of Arizona Press.

- KEYFITZ, MATHAN  
1968 Introduction to the Mathematics of Population. Reading: Addison-Wesley.
- KLUCKHOHN, CLYDE  
1956 Aspects of the demographic history of a small population, IN Estudios Antropológicos Publicados en Homenaje al Doctor Manuel Gamio, Mexico: Direccion General de Publicaciones.
- KLUCKHOHN, CLYDE AND DOROTHY LEIGHTON  
1946 The Navajo, Cambridge: Harvard Univ. Press.
- KUNSTADTER, P., R. BUHLER, F. STEPHAN AND C. WESTOFF  
1963 Demographic Variability and preferential marriage patterns, Amer. Journal of Physical Anthropology, 21:511.
- LAMPHERE, LOUISE  
1965 Community Expansion and Residence Group Fission Among the Ramah Navajo, Special Papers, Dept. of Social Relations, Harvard University.  
1970 Ceremonial Co-operation and Networks: a reanalysis of the Navajo outfit. Man (N.S.) 5:39.
- LANDAR, HERBERT  
1962 Fluctuations of form in Navajo kinship terminology. American Anthropologist 64:985.
- LEACH, EDMUND  
1961 Rethinking Anthropology, London: Athlone Press.  
1964 Political Systems of Highland Burma. Boston: Beacon.
- LEVI-STRAUSS, CLAUDE  
1966 The Future of Kinship Studies, Huxley Memorial Lecture 1965, The Royal Anthropology Society.  
1967 Les Structures Elementaires de la Parente (1949), Paris: Mouton.  
1969 The Elementary Structures of Kinship, Boston: Beacon.
- LEVY, JERROD  
1962 Community organization of the western Navajo, American Anthropologist 64:781
- MARX, KARL  
1967 Capital, Vol. III, Moscow: Progress Publishers.
- MORAN, P. A. P.  
1962 The Statistical Processes of Evolutionary Theory, London: Oxford Univ. Press.
- MORGAN, KEN  
1973a Historical demography of a Navajo community IN Methods and Theories of Anthropological Genetics (eds) H. Crawford and P. L. Workman, N. Mexico: Albuquerque Press

- MORGAN, KEN  
1973b Computer simulation of incest prohibition and clan proscrition rules in a closed, finite population IN Computer Simulation in Human Population Studies (eds.) B. Dyke and J. MacCluer, New York: Academic Press.
- POLLARD, J. H.  
1973 Mathematical Models for the Growth of Human Populations, Cambridge: Cambridge Univ. Press.
- RADCLIFFE-BROWN, A. R.  
1931 The Social Organization of Australian Tribes, Oceania Monograph # 1.
- REICHARD, DOROTHY  
1928 Social Life of the Navajo Indians, New York: Columbia Univ. Press.
- REYNOLDS, T. R., L. LAMPHERE AND C. E. COOK  
1967 Time, resources and authority in a Navajo Community
- SHEPARDSON, M. AND B. HAMMOND  
1970 The Navajo Mountain Community, Berkeley: Univ. of California Press.
- SPIHLER, J. N. AND C. KLUCKHOHN  
1953 Inbreeding coefficients of the Ramah Navajo population, Human Biology 25:295.
- TERRELL, JOHN UPTON  
1970 The Navajos, New York: Weybright and Talley.
- WHEELWRIGHT, MARY C.  
1949 Emergence Myth, Santa Fe: Museum of Navajo Ceremonial Art.
- WITHERSPOON, MARY  
1975 Navajo Kinship and Marriage, Chicago: Univ. of Chicago Press.
- YENGOYAN, A. P.  
1968 Demographic and ecological influences on aboriginal Australian marriage sections IN Man the Hunter (eds.) R. Leo and I. Devore, Chicago: Aldine.  
1972 Biological and demographic components in aboriginal Australian socio-economic organization, Oceania 43: 85.
- ZELDITCH, M.  
1959 Statistical marriage preferences of the Ramah Navaho, American Anthropologist 61:470.