

University of Alberta

The contribution of two phosphorylated surface modifications on the
pathogenesis of *Campylobacter upsaliensis*

by

Shauna Mary Crowley

A thesis submitted to the Faculty of Graduate Studies and Research in partial
fulfillment of the requirements for the degree of

Master of Science
in
Microbiology and Biotechnology

Department of Biological Sciences

©Shauna Mary Crowley
Fall 2012
Edmonton, Alberta

Permission is hereby granted to the University of Alberta Libraries to reproduce single copies of this thesis and to lend or sell such copies for private, scholarly or scientific research purposes only. Where the thesis is converted to, or otherwise made available in digital form, the University of Alberta will advise potential users of the thesis of these terms.

The author reserves all other publication and other rights in association with the copyright in the thesis and, except as herein before provided, neither the thesis nor any substantial portion thereof may be printed or otherwise reproduced in any material form whatsoever without the author's prior written permission.

Abstract

Campylobacter upsaliensis is a human pathogen most commonly associated with self-limiting gastroenteritis. Despite extensive epidemiological data indicating *C. upsaliensis* as an emerging pathogen, few studies have examined possible mechanisms of its virulence. The surface of *C. upsaliensis* is comprised of capsular polysaccharides (CPS) and lipooligosaccharides (LOS), which are likely involved in bacterial interactions with its host and environment. In this study, we demonstrated that the LOS of *C. upsaliensis* RM3195 is modified with phosphocholine (PCho) and its CPS is decorated with phosphoramidate (MeOPN) residues. These phosphorylated moieties are involved in host cell invasion potentially mediated through the platelet activating factor receptor. Also, PCho and MeOPN conversely affect bacterial survival in human serum; PCho increases *C. upsaliensis* susceptibility, while MeOPN provides protection. These results suggest that phosphorylated surface modifications play key roles in *C. upsaliensis* host survival as well as pathogenesis.

TABLE OF CONTENTS

Heading	Page number
Chapter 1. General Introduction.....	1
1.1 Introduction.....	2
1.2 <i>Campylobacter upsaliensis</i>	2
1.2.1 History and general features.....	2
1.2.2 Epidemiology.....	4
1.2.3 Clinical features.....	6
1.2.4 Virulence factors.....	8
1.2.4.1 Genome sequence.....	12
1.3 <i>Campylobacter</i> outer membrane carbohydrates.....	12
1.3.1 Lipooligosaccharides.....	12
1.3.2 Capsular polysaccharides.....	16
1.3.3 Phase variation and its role in <i>Campylobacter</i> surface presentation.....	20
1.4 Phosphorylated modification of outer surface structures.....	23
1.4.1 Phosphocholine.....	24
1.4.2 Phosphoramidate.....	28
1.5 Conclusions.....	29
1.6 M.Sc. project objectives.....	30
1.7 Literature cited.....	32

Chapter 2. The genetic manipulation of <i>C. upsaliensis</i> and the development of vector systems for complementation.....	45
2.1 Introduction.....	46
2.2 Materials and methods.....	50
2.2.1 Bacterial strains and growth conditions.....	50
2.2.2 PCR.....	54
2.2.3 Molecular cloning.....	56
2.2.4 Construction of insertional mutants.....	56
2.2.5 Natural transformation of <i>C. upsaliensis</i>	57
2.2.6 Electroporation of <i>C. upsaliensis</i>	58
2.2.7 Conjugation of <i>C. upsaliensis</i>	58
2.2.8 Sequencing.....	59
2.2.9 Phospholipid extraction and thin-layer chromatography.....	59
2.2.10 Western transfer and immunoblotting.....	60
2.2.11 LOS analysis with capillary electrophoresis-electrospray ionization mass spectrometry.....	61
2.2.12 CPS analysis by high resolution magic angle spinning NMR....	62
2.2.13 Cloning of <i>Cup_0802</i> and <i>licC</i> into existing complementation vectors.....	63
2.2.14 Cloning and construction of insertional complementation vectors.....	64
2.2.15 Cloning and construction of <i>in trans</i> complementation vectors.....	67

2.3 Results.....	68
2.3.1 The CPS of RM3195 wt is decorated with MeOPN.....	68
2.3.2 Construction of a MeOPN mutant.....	69
2.3.3 RM3195 wt modifies its LOS with PCho.....	70
2.3.4 Construction of a PCho mutant.....	73
2.3.5 CUP_0804 does not compensate for the loss of LicC.....	74
2.3.6 Construction of a double MeOPN and PCho mutant.....	74
2.3.7 Transformation of <i>C. upsaliensis</i> with existing <i>Campylobacter</i> <i>jejuni</i> complementation vectors.....	74
2.3.8 Construction of a <i>C. upsaliensis</i> complementation vector.....	75
2.3.9 Transformation of <i>C. upsaliensis</i> with pSC1, pSC1L and pSC2.....	76
2.4 Discussion.....	77
2.5 Acknowledgements.....	82
2.6 Literature cited.....	83
Chapter 3. Phosphorylated modification of the capsular polysaccharide and lipooligosaccharide affects serum resistance of <i>C. upsaliensis</i>	89
3.1 Introduction.....	90
3.2 Material and methods.....	92
3.2.1 Bacterial strains and growth conditions.....	92
3.2.2 Serum susceptibility assay.....	94
3.2.3 Western transfer and immunoblotting.....	95

3.2.4 CPS analysis by HR-MAS NMR.....	95
3.2.5 CRP- phosphatase conjugation and binding assay.....	97
3.3 Results.....	97
3.3.1 Phosphorylated modification display effects <i>C. upsaliensis</i> survival in human serum.....	97
3.3.2 MeOPN and PCho conversely effect <i>C. upsaliensis</i> serum survival.....	99
3.3.3 MeOPN and PCho alter <i>C. upsaliensis</i> RM3195 serum susceptibility via the classical complement pathway.....	101
3.3.4 CRP and SAP do not bind to <i>C. upsaliensis</i> RM3195.....	103
3.4 Discussion.....	104
3.5 Acknowledgements.....	110
3.6 Literature cited.....	111
Chapter 4. Decoration of the CPS and LOS with phosphorylated modifications alters host cell invasion of <i>C. upsaliensis</i>	116
4.1 Introduction.....	117
4.2 Material and Methods.....	120
4.2.1 Bacterial strains and growth conditions.....	120
4.2.2 Adherence and invasion assay.....	121
4.2.3 Scanning electron microscopy and transmission electron microscopy.....	123
4.2.4 Immunofluorescence microscopy.....	124
4.2.5 siRNA knockdown.....	125

4.2.6 SDS-PAGE and immunoblotting.....	126
4.3 Results.....	127
4.3.1 <i>C. upsaliensis</i> adheres to and invades intestinal epithelial cells.....	127
4.3.2 Removal of MeOPN and PCho decrease adherence and invasion of intestinal epithelial cells.....	130
4.3.3 <i>C. upsaliensis</i> co-localizes with platelet activating factor receptor.....	132
4.3.4 Addition of a platelet activating factor receptor antagonist decreases <i>C. upsaliensis</i> invasion.....	135
4.3.5 Infection with <i>C. upsaliensis</i> does not activate platelet activating factor receptor.....	138
4.4 Discussion.....	139
4.5 Acknowledgements.....	145
4.6 Literature cited.....	146
Chapter 5. General discussion, conclusions and future perspectives.....	152
5.1 Research purpose.....	153
5.2 Summary of research presented and future directions.....	153
5.2.1 Genetic manipulation of <i>C. upsaliensis</i> and the conservation of PCho and MeOPN among <i>Campylobacter</i> and <i>C. upsaliensis</i>	153
5.2.2 MeOPN and PCho alter <i>C. upsaliensis</i> serum susceptibility.....	156

5.2.3 Host cell invasion requires decoration of <i>C. upsaliensis</i> with MeOPN and PCho.....	158
5.3 Conclusions.....	160
5.4 Literature cited.....	162
Appendix 1. MeOPN and PCho expression does not influence polymyxin B sensitivity, bacterial survival in a <i>Galleria mellonella</i> pathogenesis model or biofilm formation.....	166
A1.1 Introduction.....	167
A1.2 Material and Methods.....	168
A1.2.1 Bacterial strains and growth conditions.....	168
A1.2.2 Polymyxin B minimum inhibitory concentration (MIC).....	169
A1.2.3 Polymyxin B sensitivity.....	169
A1.2.4 <i>G. mellonella</i> pathogenesis model.....	170
A1.2.5 Biofilm assay.....	170
A1.3 Results and discussion.....	171
A1.3.1 MeOPN and PCho expression does not influence polymyxin B sensitivity.....	171
A1.3.2 Pathogenesis in a <i>G. mellonella</i> model is not influenced by MeOPN and PCho expression.....	175
A1.3.3 Biofilm formation is not altered by modification with MeOPN and PCho.....	177
A1.4 Literature cited.....	179

Appendix 2. Phase variable expression of capsular polysaccharide modifications allows <i>C. jejuni</i> to avoid bacteriophage infection in chickens.....	182
A2.1 Introduction.....	183
A2.2 Material and Methods.....	186
A2.2.1 Bacterial strains, media and growth conditions.....	186
A2.2.2 Bacteriophages.....	187
A2.2.3 Bacteriophage propagation.....	188
A2.2.4 Bacteriophage titration.....	189
A2.2.5 Plaque assay.....	189
A2.2.6 HR-MAS NMR spectroscopy.....	190
A2.2.7 <i>In vivo</i> chicken experiments.....	190
A2.3 Results.....	191
A2.3.1 The MeOPN moiety of the capsular polysaccharide of <i>C. jejuni</i> NCTC11168 is a receptor for several phages.....	191
A2.3.2 The location of the MeOPN on the CPS is important for phage infection.....	193
A2.3.3 <i>C. jejuni</i> phages require different combinations of phase variable CPS modifications for successful infection.....	196
A2.3.4 Selection for phage resistant variants during <i>C. jejuni</i> colonization of chickens.....	201
A2.4 Discussion.....	205
A2.5 Acknowledgements.....	209

A2.6 Literature cited.....	211
----------------------------	-----

LIST OF TABLES

Table 2.1 Strains and plasmids used in this study.....	52
Table 2.2 Oligonucleotides used in this study.....	55
Table 2.3 Summary of complementation vectors constructed and transformation attempts.....	75
Table 3.1 Strains used in this study.....	93
Table 4.1 Strains used in this study.....	120
Table A1.1 Strains used in this study.....	168
Table A1.2 Minimal inhibitory concentration of polymyxin B for <i>C. upsaliensis</i>	173
Table A2.1 <i>C. jejuni</i> strains.....	187
Table A2.2 Bacteriophages.....	188
Table A2.3 Efficiency of plaquing (EOP) of phages related to F336 as compared to NCTC 11168.....	192
Table A2.4 ppm values for ¹ H-HR-MAS NMR spectra for NCTC11168 variants and MeOPN transferase status.....	198
Table A2.5 Presence of MeOPN and phage sensitivity of <i>C. jejuni</i> isolated after colonization of chickens.....	202

LIST OF FIGURES

Figure 1.1 <i>C. jejuni</i> LOS outer core structures exhibiting molecular mimicry of gangliosides.....	14
Figure 1.2 CPS structures of <i>C. jejuni</i>	18
Figure 2.1 Dendrogram of epsilonproteobacterial AtpA amino acid sequences.....	47
Figure 2.2 Construction of RM3195 genomic integration vector pSC1 and pSC2.....	66
Figure 2.3 The CPS of <i>C. upsaliensis</i> RM3195 is modified by MeOPN and mutation to <i>Cup_0802</i> removes this modification.....	69
Figure 2.4 The LOS of <i>C. upsaliensis</i> RM3195 is decorated by PCho and mutation to <i>licC</i> removes this modification.....	71
Figure 2.5 The PCho modification is located on the LOS, and does not decorate a proteinaceous substrate or is it present as phosphatidylcholine.....	72
Figure 3.1 Resistance to human serum is not reflective of presence or absence of PCho, MeOPN or source of strain origin.....	98
Figure 3.2 <i>C. upsaliensis</i> resistance to the bactericidal activity of human serum.....	100
Figure 3.3 <i>C. upsaliensis</i> resistance to the bactericidal activity of human serum is altered in the presence of EGTA.....	102
Figure 3.4 CRP binding to RM3195.....	104

Figure 4.1 TEM and SEM of <i>C. upsaliensis</i> of adherence to and invasion of Caco-2 cells.....	128
Figure 4.2 Removal of MeOPN or PCho decreases <i>C. upsaliensis</i> ability to adhere to Caco-2 intestinal epithelial cells.....	131
Figure 4.3 Removal of MeOPN or PCho decreases <i>C. upsaliensis</i> ability to invade Caco-2 intestinal epithelial cells.....	132
Figure 4.4 Representative immunofluorescence microscopy images of <i>C.</i> <i>upsaliensis</i> -infected Caco-2 cells demonstrating RM3195 wt co-localization with PAFR.....	134
Figure 4.5 <i>C. upsaliensis</i> PCho-modified LOS co-localizes with Caco-2 PAFR.....	135
Figure 4.6 Addition of a PAFR antagonist decreases <i>C. upsaliensis</i> ability to invade Caco-2 intestinal epithelial cells but does not alter invasion of <i>Cup_0802::cat</i> or <i>licC::cat</i> mutants.....	136
Figure 4.7 Representative western blot of attempted knockdown of PAFR by pooled siRNA directed against PAFR.....	137
Figure 4.8 <i>C. upsaliensis</i> does not activate PAFR to undergo self phosphorylation within 10 min after infection.....	138
Figure A1.1 Display of PCho or MeOPN does not influence survival of <i>C. upsaliensis</i> in polymyxin B.....	173
Figure A1.2 Display of PCho or MeOPN does not influence survival of <i>C. upsaliensis</i> in a <i>G. mellonella</i> infection model.....	176

Figure A1.3 Display of PCho or MeOPN does not influence biofilm formation of <i>C. upsaliensis</i>	178
Figure A2.1 CPS structures expressed by defined MeOPN transferase mutants and their affect on phage sensitivity.....	195
Figure A2.2 HR-MAS NMR spectra showing the differences in CPS modifications between NCTC11168 variants MP24, MP25 and MP26.....	197
Figure A2.3 CPS structures expressed by NCTC11168 variants and the corresponding phage sensitivity profiles.....	200
Figure A2.4 NMR analysis of intact <i>C. jejuni</i> cells recovered from chicken cecal contents.....	203

LIST OF SYMBOLS, NOMENCLATURE, AND ABBREVIATIONS

AP: Alkaline phosphatase

CE-ESI: Capillary electrophoresis electrospray ionization

CFU: Colony forming unit

CNW: Catalase-negative weak

CPS: Capsular polysaccharide

CRP: C-reactive protein

EGTA: Ethylene glycol tetraacetic acid

Fru: Fructose

Gal: Galactose

GalNAc: N-acetyl-galactosamine

GBS: Guillain Barré syndrome

Glc: Glucose

GlcA: Glucuronic acid

GlcN: D-glucosamine

GlcN3: 2,3-diamino-2,3-dideoxy-D-glucose

Gro: Glycerol

Hep: *L-glycero-D-manno*heptose

Hep1: Heptose residue directly adjacent to the Kdo

Hep2: Heptose residue adjacent to Hep1

HR-MAS: High resolution magic angle spinning

Kdo: 2-keto-3-deoxyoctulosonic acid

LOS: Lipooligosaccharide

LPS: Lipopolysaccharide

Neu5Ac: N-acetylneuraminic acid

Man: Mannose

MeOPN: Methyl-O-phosphoramidate

MOI: Multiplicity of infection

MS: Mass spectrometry

NBT-BCIP: Nitroblue tetrazolium-5-bromo-4-chloro-3-indolylphosphate

NEtn: Ethanolamine

NGro: Aminoglycerol

NMR: Nuclear magnetic resonance

OD: Optical density

P: Phosphate

PAF: Platelet activating factor

PAFR: Platelet activating factor receptor

PBS: Phosphate buffered saline

PBST: Phosphate buffered saline with 0.1 % Twen

PCho: Phosphocholine

PCR: Polymerase chain reaction

PEtn: Phoshoethanolamine

PFU: Plaque forming unit

Rib: Ribose

SAP: Serum amyloid P component

TAMRA: Tetramethylrhodamine azide

TSP: 3-(trimethylsilyl)propionic-2,2,3,3-*d*₄ acid sodium salt

TLC: Thin layer chromatography

CHAPTER 1

General introduction

1.1 Introduction

Campylobacter upsaliensis is an intestinal pathogen most commonly associated with acute self-limiting gastroenteritis. It has also been isolated from patients presenting with bacteremia, extraintestinal infection, spontaneous abortion, hemolytic uremic syndrome and Gullian-Barré syndrome (GBS) (14, 17, 27, 32, 42, 45). Despite the large body of evidence linking *C. upsaliensis* with human disease, little is known about the virulence factors and the mechanisms by which this organism causes illness. *C. upsaliensis* is also sensitive to many antibiotics used in *Campylobacter*-selective media (6, 37, 85). This suggests that the actual contribution of *C. upsaliensis* to overall *Campylobacter* infection, which is the most common cause of food poisoning worldwide, may be under reported.

This introduction will summarize the current body of literature concerning *C. upsaliensis* and disease, and the known virulence mechanisms of *C. upsaliensis* placed in context with the *Campylobacter* genera. The role of *Campylobacter* surface structures will also be discussed and their possible contribution to *C. upsaliensis* pathogenesis through modification with unique phosphorylated moieties.

1.2 *C. upsaliensis*

1.2.1 History and general features

The first reported isolation of *C. upsaliensis* was in 1983 in Uppsala, Sweden, from a dog presenting with diarrhea (101). The isolation revealed a new

novel class of *Campylobacter* isolates that were catalase negative/catalase weak (CNW). In 1985, the first human CNW strain was isolated from the stool of a gastroenteritis patient indicating the isolation of these organisms correlated with human disease (111). DNA-DNA hybridization revealed the CNW group represented a new species and was named '*C. upsaliensis*,' after the city in which it was first reported (98, 100, 101).

C. upsaliensis is a microaerophilic, thermotolerant, Gram-negative spiral shaped bacterium (11). It is approximately 0.3 to 0.4 μm wide and 1.3 to 3 μm long. It has bipolar flagella and exhibits a darting motility, which is characteristic of the *Campylobacter* genera. It can be differentiated from other *Campylobacter* species through its lack of catalase activity, inability to hydrolyze hippurate, lack of hydrogen sulfide production on triple sugar iron media, and its positive oxidase test (2, 11, 86, 100).

Interestingly, *C. upsaliensis* exhibits an intraspecies genetic heterogeneity. Macrorestriction profiles elucidated by pulse-field gel electrophoresis have revealed little similarity across a range of *C. upsaliensis* strains (12, 82). However there appears to be some genomic conservation between strains that were in the same Lior serogroup, a typing method designed to differentiate between *Campylobacter* presentation of heat-labile antigens (12). The Lior typing method is commonly used to classify *C. upsaliensis* strains because they are difficult to type using the more commonly used Penner serotyping scheme, which detects antigenic *Campylobacter* surface structures, primarily capsular polysaccharides

(CPS). A probable reason for this inability to Penner type *C. upsaliensis* could be a difference in CPS structures from *C. jejuni* and *Campylobacter coli* for which the method was developed.

1.2.2 Epidemiology

C. upsaliensis is frequently isolated from the stools of healthy and diseased dogs and cats (21, 24, 81, 101). There have also been sporadic reports of its isolation from other animal sources including cattle and poultry (7, 63).

Utilizing a non-selective filtration-based method to study the stool of domestic and laboratory cats, Moreno and colleagues detected an extremely high *C. upsaliensis* carriage of 66 % (81). This was correlated by a study of healthy pet dogs across a community in Cheshire, England (127). Of the 183 dogs tested, 25.2 % were positive for *C. upsaliensis*. Only one *C. jejuni* and one *C. coli* strain were isolated in total, indicating *C. upsaliensis* comprised the majority of the overall *Campylobacter* canine carriage, and its isolation does not consistently associate with animal disease. The highest *C. upsaliensis* carriage rate in dogs currently reported is 88 %. The authors attributed this abnormally high rate to the study's location, an Irish shelter, where the high population density and close proximity of kennels was believed responsible for the high *C. upsaliensis* prevalence (1).

Currently, two reports support the theory of *C. upsaliensis* transmission from animals to humans. Goosens and colleagues isolated a *C. upsaliensis* strain from the stool of a 53-year-old man presenting with acute onset pyrexia, lower abdominal cramps and bloody diarrhea (36). Phenotypic characterizations,

antibiotic susceptibility, plasmid analysis, protein profiles and immunotyping, revealed the *C. upsaliensis* strain isolated from the patient's 3-year-old healthy dog were nearly identical. Zoonotic transmission was also believed responsible for the extra-intestinal *C. upsaliensis* infection of a 26-year-old woman that had suffered a spontaneous abortion at 18 weeks gestation (42). The patient had no underlying disease and had given birth three years previous with no complications. A *C. upsaliensis* strain was isolated from the stool of the patient's healthy 3-year-old cat. Protein and biochemical profiles as well as antibiotic susceptibility tests were identical for both strains. Despite this propensity for dogs and cats to act as *C. upsaliensis* reservoirs, there have been reports indicating dogs may not be the source of human infection. According to one study, canine-specific and human-specific *C. upsaliensis* genotypes cluster separately and share less than 40 % similarity between groups (19, 110).

There is limited information concerning *C. upsaliensis* person to person transmission. Walmsley and Karmali isolated identical *C. upsaliensis* strains from two patients sharing the same Toronto hospital room on the basis of biochemical analysis (121). There is also the report of a *C. upsaliensis* outbreak in four daycare centres across Brussels, Belgium affected 44 children (34). Strains were profiled by biotyping, restriction fragment length polymorphism, antibiotic susceptibility as well as protein and plasmid profiles. The strains divided into two strongly related clonal variants with one strain isolated from the first daycare and the second isolate from the other three.

1.2.3 Clinical features

C. upsaliensis is most commonly associated with acute self-limiting gastroenteritis and has been observed in various countries over four continents (6, 34, 35, 44, 59, 61, 72, 85, 111, 118). Interestingly, multiple investigations have isolated *C. upsaliensis* more frequently than *C. coli*, a recognized human enteropathogen, from the stools of paediatric patients presenting with diarrhea (37, 56, 61). A large scale evaluation of the bacterial composition of stool samples in Belgium patients identified 99 *C. upsaliensis*-containing samples, out of the 15,185 specimens examined (37). Clinical information was available for 77 of these patients (73 children and four adults) in which 92 % had diarrhea. In a separate study, a *C. upsaliensis* outbreak was investigated in four separate daycare centres in Brussels, Belgium, which affected 44 children in which the majority presented with mild and self-limiting diarrhea (34). However some children experienced a chronic and recurrent diarrhea.

C. upsaliensis can cause bacteremia in immunocompromised and immunodeficient patients. In a study by Patton *et al.*, *C. upsaliensis* was isolated from the blood of eight patients ranging in age from six months to 83-years-old (85). Six of these patients had underlying medical conditions that may have predisposed them to opportunistic infection, while the two others had recently undergone abdominal surgery. *C. upsaliensis* bacteremia has also been reported in a 16-year-old boy with the chronic inflammatory disease lupus erythematosus, as

well as hypogammaglobulinemia, an immune disorder characterized by low levels of immunoglobulins (17).

In addition, *C. upsaliensis* infection has been linked with hemolytic-uremic syndrome. A 14-year-old boy presenting with profuse watery diarrhea and abdominal pain developed microscopic hematuria, thrombocytopenia and acute renal failure in the hospital (14). A renal biopsy confirmed hemolytic-uremic syndrome and *C. upsaliensis* was isolated from his stool. No other pathogens were isolated from this patient and PCR analysis failed to amplify verotoxin genes from the stool, eliminating *Escherichia coli* as a possible etiological agent.

Although the majority of *C. upsaliensis*-associated disease affects the intestine, there have been reports of extra-intestinal infections. *C. upsaliensis* was isolated from blood cultures and fetoplacental material from a woman suffering a spontaneous abortion (42). Utilizing a non-selective media, *C. upsaliensis* was the only pathogen isolated by the authors. *C. upsaliensis* was also isolated from the cultured biopsy tissue from a breast abscess (27).

Currently there are two reports linking *C. upsaliensis* infection with the post-infectious polyneuropathy known as GBS. GBS is an autoimmune disorder affecting the peripheral nervous system. It has been linked with *C. jejuni* infection due to patient production of antibodies directed against *C. jejuni* LOS, whose structure can mimic gangliosides (3). Antibodies generated against LOS cross-react with the patient's myelin sheaths producing the nerve damage of this disorder. Ho *et al.* described an acute motor axonal neuropathy pattern of GBS in

a 64-year-old woman that originally presented with *C. upsaliensis*-associated diarrhea (45). Anti-*C. upsaliensis* LOS antibodies were present in her serum, including the anti-ganglioside GM1 antibodies. Another report detailed a *C. upsaliensis* strain from a 4-year-old child in South Africa suffering from GBS (32).

1.2.4 Virulence factors

Some bacterial pathogens are reliant on a plethora of virulence factors a given bacterium encodes. *C. upsaliensis* has been studied since the early 1980's, but the majority of reports pertain to its epidemiology and disease manifestation. The study of the molecular virulence mechanisms of *C. upsaliensis* is still in its infancy and only a handful of papers have investigated putative virulence factors.

Flagella have been consistently associated with *Campylobacter* virulence (38, 83, 122). They are required for *C. jejuni* motility, colonization and secretion of effector proteins (55). Mutation of *flaA*, encoding the major protein component of the *C. jejuni* flagella, significantly decreases bacterial invasion of INT-407 cells (122). However, invasion levels were partially restored by gentle centrifugation of the *flaA* mutants onto the surface of the cell. This implicates flagella as an integral *Campylobacter* adherence ligand. Consistent with other *Campylobacters*, *C. upsaliensis* is motile and has bipolar flagella. Its flagellar antigens exhibit strong cross reactivity with antibodies to pathogenic *C. jejuni* and *C. coli* isolates (73). However there have been no reports exploring the potential role of *C. upsaliensis* flagella in pathogenesis.

C. upsaliensis has been observed to adhere to purified human small-intestinal mucin, CHO and HEP-2 cell lines as well as an endothelial cell monolayer (72, 114). The binding of *C. upsaliensis* to CHO and HEP-2 cells was “virtually indistinguishable” from the diffuse adherence exhibited by the *C. jejuni* positive control (114). The authors also detected binding of *C. upsaliensis* to host cell phosphatidylethanolamine, gangliosylceramide and more weakly to phosphatidylserine by a thin-layer chromatography binding assay. *C. jejuni* also strongly binds to host cell phosphatidylethanolamine (116). Currently there are no reports of *C. upsaliensis*-specific adhesions that facilitate bacterial binding to host cells.

Mooney and colleagues examined *C. upsaliensis* invasion of primary human small intestinal cells as well as the intestinal epithelial cell lines Caco-2 and INT-407 (75). Similar to *C. jejuni*, *C. upsaliensis* demonstrated optimal invasion in sub-confluent monolayers that were intestinal-derived. The most efficient invasion occurred at lower initial inocula, however the number of intracellular organisms increased when the MOI was raised. Both microfilament (cytochalasin B and D) and microtubule inhibitors (vinblastine) attenuate invasion in a concentration-dependent manner. This indicates that similar to *C. jejuni*, *C. upsaliensis* utilizes both microfilament- and microtubule-based cytoskeleton rearrangements for invasion. It is important to note that *C. jejuni* invasion via a microfilament and/or microtubule mechanism is still a point of contention. The confluence of the cell monolayer as well as the composition of the cell media can

affect which cell structure is/are utilized for *C. jejuni* invasion (10, 46, 74, 123). Additional study is required to better characterize how *C. upsaliensis* invades, and the moieties it requires for host cell invasion.

C. upsaliensis was first reported to produce a cytolethal distending-like toxin (CDT) in 1993 (22). Pickett and colleagues later identified a *cdtB* homolog in *C. jejuni*, and although *C. upsaliensis* ATCC43954 did not hybridize to the *cdtB* probe, it did produce a CDT-like effect on HeLa cells (87). This toxin was further characterized by Mooney *et. al.* in 2001 (76). *C. upsaliensis* whole cell preparations as well as extracts exhibited a progressive distension and nuclear fragmentation of HeLa cells over five days, which cumulated in cell death. Propidium iodide staining revealed cell cycle arrest occurred in G(2)/M. *C. upsaliensis* whole cell preparations also arrested T lymphocytes in G(2)/M. This is the only report of a specific *C. upsaliensis* virulence factor, but the contribution of *C. upsaliensis* CDT in host cell invasion has never been explored.

1.2.4.1 Genome sequence

The genome of *C. upsaliensis* RM3195 was recently sequenced by Fouts *et. al.* and represents a significant move forward in our understanding of molecular virulence factors encoded by *C. upsaliensis* (23). A sequenced genome allows for putative virulence genes to be identified and genetically manipulated through established *Campylobacter* mutation techniques (57, 58). *C. upsaliensis* RM3195 (ATCC BAA-1059) is a clinical strain, originally obtained from the feces of a 4-year-old GBS patient (23). The genome consists of a single 1.68 Mb

chromosome, a smaller 3.1 kb plasmid and a 0.11 Mb megaplasmid. The smaller plasmid appears to contain a defined plasmid replication region as well as a putative addiction toxin with high protein homology to the RelE/StbE class of addiction toxins.

Interestingly, despite *C. upsaliensis* RM3195 and *C. jejuni* RM1221 appearance of dissimilarity, based on a 16S rRNA phylogenetic tree, the two appear to contain high protein homology (1,261 proteins with 74.7 % average protein identity) (23). *C. upsaliensis* contains closely related homologues of the open reading frames (ORFs) required for flagellar biosynthesis and function, chemotaxis, two component regulatory expression systems, CDT production and expression of multiple adhesins including CadF, Peb1 and JlpA (13, 23).

A unique feature identified in RM3195 is an extensive restriction modification system. RM3195 contains one Type II, two Type III and three or possibly four, Type I (the fourth loci is missing *hsdR*), putative restriction modification loci. It also encodes 15 putative adenine- or cytosine-specific DNA methyltransferases. *Campylobacter* species usually encode a small number of restriction modification loci, which is at odds with *C. upsaliensis* RM3195. RM3195 may have acquired this restriction modification arsenal from a *Helicobacter* species. This would correct the atypical nucleotide composition surrounding the restriction modification loci (54).

Another feature identified in RM3195 that is absent from all currently sequenced *C. jejuni* genomes, is the presence of a putative *licABCD* locus (23).

This locus encodes enzymes for the biosynthesis of phosphocholine (PCho), a phosphorylated moiety commonly used by *Haemophilus* spp., *Neisseria* spp. and *Streptococcus pneumoniae* for decoration of their LOS, proteins or teichoic/lipoteichoic acids (60, 104, 126). This is the first report to our knowledge of an intestinal pathogen containing *licABCD*.

C. upsaliensis appears to mirror aspects of *C. jejuni* pathogenesis, but it contains unique putative virulence features that may contribute to its individual pathogenesis. There are currently no reports that study specific *C. upsaliensis* virulence gene products utilizing genetic manipulation. The ability to construct isogenic mutants will be an important step in the characterization of this pathogen, and will enable further understanding about its role in human disease.

1.3 *Campylobacter* outer membrane carbohydrates

The outer surface of *C. upsaliensis* is comprised of CPS and LOS. CPS and LOS are integral to host cell invasion, serum survival and pathogenesis in animal models for *C. jejuni* (8, 16, 39, 41, 47, 89, 99). They are the outermost structures of the bacterium and are the first physical surface by which the bacterium and host cell interact. The CPS and LOS have been consistently implicated as virulence factors among *Campylobacters*, and as such, merit study in *C. upsaliensis*.

1.3.1 LOS

LOS constitutes an integral part of the outer membrane due to its role in structural integrity and its function as a barrier device. LOS is comprised of a

lipid A molecule substituted with a short oligosaccharide core (91). It does not contain an elongated repeating O-antigen, such as in the LPS of *E. coli* or *Salmonella enterica* serovar Typhimurium (93).

C. jejuni NCTC 11168 lipid A, the hydrophobic anchor of its LOS, is a mixed disaccharide core consisting of a D-glucosamine (GlcN) and 2,3-diamino-2,3-dideoxy-D-glucose (GlcN3), variably phosphorylated with phosphates or phosphoethanolamine residues and acylated with palmitic or lauric acid (80, 109). This is in contrast to enterobacterial lipid A which is made up of a GlcN disaccharide backbone and contain less N-acyl chains (93). *C. jejuni* LOS antigenically resembles classical *Enterobacteriaceae* lipid A, but its pyrogenicity was 30- to 50-fold lower compared to *S. Typhimurium* (77). In another species, *Campylobacter fetus*, the lipid A molecule contains a GlcN disaccharide that is acylated with varying myristic and palmitic acids (79)

The core oligosaccharide of *C. jejuni* is subject to interstrain variability and can be divided into a conserved “inner core” and variable “outer core” (Figure 1.1) (30). The LOS inner core usually consists of a heptose disaccharide of L-glycero-D-manno-heptose (30, 50, 78). This is attached to 2-keto-3-deoxyoctulosonic acid (Kdo), which connects to lipid A (50, 78). This inner core is usually decorated with D-glucose in a β -(1→4) linkage on the heptose directly adjacent to the Kdo (Hep1), as well as the addition of phosphoethanolamine or a phosphate group on the neighboring heptose (Hep2) (78). The *C. jejuni* LOS outer core sugar composition is much more diverse, and specific strain make up can be

grouped by serotype. The outer core contains sugars such as D-glucose, D-galactose, *N*-acetyl-D-glucosamine and *N*-acetyl-D-galactosamine, and these are further substituted with *N*-acetylneuraminic acid, D-glucose and D-galactose (30). The presentation of *N*-acetylneuraminic acid on the LOS mimics human gangliosides and infection with *C. jejuni* strains that contain these substitutions have been linked to GBS as mentioned above (90).

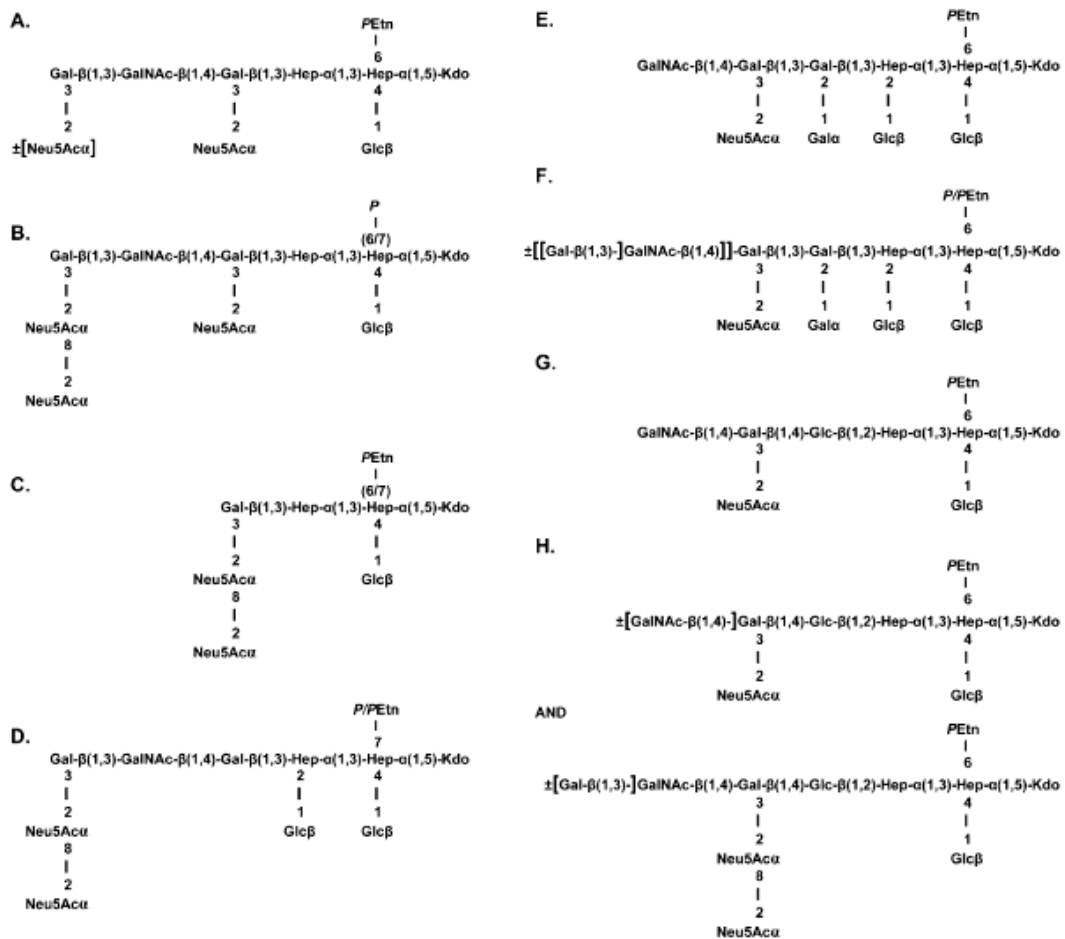

Figure 1.1 *C. jejuni* LOS outer core structures exhibiting molecular mimicry of gangliosides. Core structures of **A)** serostrains HS:19 and HS:4 (GM1a and GD1a mimics), **B)** isolate OH4384 (GT1a mimic), **C)** isolate OH4382 (GD3 mimic), **D)**

serostrain HS:10 and isolate PG836 (GD3 and GD1c mimics), **E**) serostrain HS:1 (GM2 mimic), **F**) serostrain HS:2 (GM3 mimic, i.e., without Gal(1→3)-GalNAc-(1→4)) and NCTC 11168 (also HS:2 serotype but outer core mimics GM1a and GM2 due to phase-variable terminal Gal), **G**) serostrains HS:23 and HS:36 (GM2 mimic), and **H**) phase-variable strain 81176 (GM2 and GM3 and mimics predominantly, but also GD1b and GD2). All sugars are in the pyranoside form and are D-enantiomers. Gal, galactose; GalNAc, N-acetyl-galactosamine; Glc, glucose; Hep, L-*glycero*-D-*manno*heptose; Kdo, 2-keto-3-deoxyoctulosonic acid; Neu5Ac, N-acetylneuraminic acid; P, phosphate; PEtn, phosphoethanolamine. Reprinted with permission from (30), p. 485. Copyright © 2008. ASM Press. All rights reserved.

The core structure of other *Campylobacter* species do not appear to contain structural similarities to *C. jejuni* LOS (30). The outer LOS core of *C. coli* contains a unique sugar, 3-amino-3,6-dideoxy-D-glucose, while the core of *Campylobacter lari* consists of similar sugars to *C. jejuni* but is recognized as a distinct serotype, indicating a difference in overall LOS structure (5, 9). Also of interest, *C. fetus* strains produce a high molecular weight LPS instead of the typical *Campylobacter* LOS (79).

The LOS structure of *C. upsaliensis* has not yet been solved, however information can be predicted based on the recent completion of the genome sequence of strain RM3195. The LOS biosynthesis locus of RM3195 is flanked

by homologs of the heptosyltransferase genes; *waaC* and *waaF*, consistent with the genomic arrangement in *C. jejuni* (23). This indicates that *C. upsaliensis* may conserve the disaccharide inner core of *C. jejuni*. However between these genes are areas exhibiting considerable variation in ORF content that has been previously linked to the synthesis of novel LOS structures (29). *C. upsaliensis* RM3195 contains a number of ORF clusters that have homologs in *C. jejuni* NCTC 11168, but these genes are not implicated in *C. jejuni* 11168 LOS biosynthesis (23). The possible function of these ORFs to *C. upsaliensis* LOS biosynthesis remains unclear.

LOS is required for optimal *C. jejuni* host cell adherence and invasion as evidenced by a reduction in invasion by truncated LOS mutants (26, 39, 41, 71). Truncation to the LOS also impairs the ability of *C. jejuni* to colonize chickens at low inoculums (26). In addition, the LOS plays a role in the avoidance of the host cell immune responses: *N*-acetylneuraminic acid mutants experienced a greater immunoreactivity and increased human serum susceptibility compared to *C. jejuni* wild type (39, 41).

1.3.2 CPS

Early reports of *C. jejuni* outer membrane composition described the presence of both a high and low molecular weight LPS (50). The low molecular weight moiety was later identified as LOS, while the high molecular weight structure was classified as CPS, after discovering that mutation to the LOS

biosynthetic genes did not alter expression of the high molecular weight polysaccharides (51).

The CPS of *C. jejuni* consists of a diacylglycerol phosphate anchor attached to variable repeating sugar units, which are grouped based on serotype (Figure 1.2) (52, Reid CW, personal communication). The repeating unit of HS:1 CPS consists of a galactose residue linked via glycerol phosphate bridges which are further substituted with fructofuranose and *O*-methyl-phosphoramidate (MeOPN) (69). The MeOPN modification can also be found on HS:2, HS:36 and HS:19 serotypes (47, 68, 117). Other CPS modifications involve decoration with sorbofuranose in HS:19 and modification with *O*-methyl, ethanolamine or aminoglycerol groups in HS:2 (68, 109).



Figure 1.2 CPS structures of *C. jejuni*. HS:1 (McNally *et al.*, 2005), HS:2, (Karlyshev *et al.*, 2005; McNally *et al.*, 2007), HS: 3 (Aspinall *et al.*, 1995), HS:6, (Muldoon *et al.*, 2002), HS:19 (McNally *et al.*, 2006), HS:23/36 (Aspinall *et al.*, 1995), and HS:53 (Gilbert *et al.*, 2007). Some side chain groups may be absent as a result of structural variation. Fru, fructose, Hep, heptose, Gal, galactose; Glc, glucose; GlcA, glucuronic acid; Gro, glycerol; Man, mannose;

Rib, ribose; NGro, aminoglycerol; NEtn, ethanolamine; MeOPN, O-methyl phosphoramidate. Furanose and pyranose configurations of sugars are denoted by letters *f* and *p*, respectively. Reprinted with permission from (52), p. 511.

Copyright © 2008. ASM Press. All rights reserved.

This diversity in repeating sugar unit is correlated to variation in the genetic make-up of the *C. jejuni* CPS biosynthetic locus (48, 51). This gene cluster can be divided into three major regions; two flanking semi-conserved clusters that contain the genes necessary for sugar polymerization and translocation to the cell surface, and an inner highly variable region that contains the genes necessary for sugar biosynthesis (52). The size of this variable region was found to vary between 15.2 kb for HS:1 to 34.1 kb for HS:41 (48). DNA hybridization analysis has demonstrated a correlation between *C. jejuni* strain serotype and gene composition of this inner region (20). Interestingly, the CPS orthologs in *C. upsaliensis* RM3195 are not contained within a single region such as in *C. jejuni*, but instead broken into three clusters (23). The first centers around *Cup_0126* and *Cup_0127*, which encode the *kpsS* and *kpsC* homologs, the second at *Cup_0787* and *Cup_806*, which contains *kpsFDETM*, among various CPS modification biosynthetic homologs and finally, *Cup_1226* to *Cup_1229*, which encode other CPS biosynthetic proteins. It is important to note, that these three clusters do not divide into the three regions described earlier in this section. The

middle cluster contains ORFs that are unique to *C. upsaliensis*, such as a putative GDP-fucose synthetase.

CPS is involved in *Campylobacter* virulence. A *C. jejuni* mutant that lacks CPS demonstrated reduced adherence and invasion of an INT-407 intestinal cell line (8). This mutant also exhibited increased serum susceptibility and increased surface hydrophobicity, which both indicate reduced survival in the host environment. CPS mutants also demonstrate attenuated virulence in animal models such as a ferret diarrheal pathogenesis model and a *Galleria mellonella* pathogenesis model (8, 16). The *C. jejuni* capsule has also been reported to demonstrate an immunosuppressive effect through the prevention of excessive cytokine production by dendritic cells (99).

1.3.3 Phase variation and its role in *Campylobacter* surface presentation

CPS and LOS play integral roles in *C. jejuni* adherence and invasion of intestinal epithelial cells (8, 41). However due to the location of these moieties on the bacterial surface, they are under constant assault by the host immune response. To rectify the interplay between these two pressures, the LOS and CPS of *Campylobacter* undergo phase-variable modification with incorporation of various non-glycosidic moieties or removal of these substitutions to produce a variable population. Phase variation allows bacteria to survive rapidly changing environments through random switching of the frequency of certain phenotypes. *Campylobacter* attains this through the presence of long homopolymeric tracts in their genomic DNA that lead to slipped-strand mispairing during chromosomal

replication (43). In *C. jejuni* it is estimated that there are greater than 700 different CPS variants and this is regulated through phase variation (40, 107). Depending on the selection environment, a clonal population will thrive while others will be selected against. As the host cell invasion process proceeds, the bacteria will be exposed to different sets of environmental pressures, and phase variation provides a quick response to ensure bacterial infection persists.

The *C. jejuni* NCTC 11168 LOS biosynthetic locus contains two areas with homopolymeric tracts; *cj1139* (*wlaN*) and *cj1144/cj1145* (84). A guanine tract length of eight residues prior to the initiation codon of *wlaN* produced the full length gene product and the GM1a ganglioside mimic LOS structure (62). Variants containing nine guanine residues introduced a premature stop codon, which subsequently produced a LOS that lacked the terminal β -(1 \rightarrow 3) galactose residue and produced a GM2-like ganglioside mimic. In *C. jejuni* 81-176, a homopolymeric tract length of ten allows for full length read of *cgtA* which produces a GM2 LOS mimic (41). A length of twelve or ten guanines created a truncated GM3-like LOS.

Genes within the *C. jejuni* CPS loci are also prone to phase variation. *C. jejuni* NCTC 11168 contains six genes with homopolymeric tracts while *C. jejuni* 81-176 contains five (48, 84) in this cluster. Addition of terminal *O*-methyl, ethanolamine, aminoglycerol and MeOPN groups appear to be under regulation of phase variation (40).

C. upsaliensis is especially amenable to phase variation due to the presence of 209 homopolymeric repeats, either poly G or poly C tracts, within its genome (23). This is approximately five times as many poly G:C tracts as *C. jejuni* RM1221 and 22 times as many as *C. coli* RM2228. The majority of these variable regions lie in ORFs associated with the biosynthesis and modification of the CPS and LOS, as well as expression of surface and virulence proteins, such as flagella. Of note are two phase variable phosphorylated modifications, PCho and MeOPN, which would modify LOS and CPS, respectfully.

Based on the recently published genome sequence of *C. upsaliensis* RM3195, it is predicted to encode the PCho biosynthetic locus, *licABCD* (23). Interestingly, similar to the *licABCD* locus in *H. influenzae*, this same gene cluster in *C. upsaliensis* is regulated by phase variation. *H. influenzae* PCho expression is controlled by the presence of a variable number of 5'-CAAT-3' tandem repeats within the promoter of *licA* (124, 125). A change in the number of copies of this tandem repeat, through slipped-strand mispairing, shifts the initiation codon in or out of frame with the remainder of *licA*, creating a translational switch (124). Weiser and colleagues estimated the frequency of this on-off switching at approximately 10^{-2} to 10^{-3} per generation. A 15 bp poly-G tract is located within *licA* of *C. upsaliensis* which also most likely regulates its translation and LOS modification.

Phase variation of MeOPN modification on the CPS in *C. jejuni* NCTC 11168 is regulated by the poly-G tracts present in both *cj1421* and *cj1422* (70).

Cj1421 and Cj1422 are homologous MeOPN-transferases, which conserve their N and C termini, and exhibit overall 55 % protein identity to one another (48). Cj1421 adds MeOPN to the furanoside, β -D-N-acetyl-galactosamine. Cj1422 adds MeOPN to D-glycero- α -L-gluco-heptopyranose (70). Shifts in the homopolymeric tracts within these proteins alters the CPS residue that are modified with MeOPN (69, 70, 107). This has been observed both *in vitro* and *in vivo* in a chicken colonization model. Our analysis of *C. upsaliensis* RM3195 genome has revealed it encodes four potential *cj1421/1422* homologs; *Cup_0217*, *Cup_0658*, *Cup_1069*, and *Cup_1202*. Each of these putative MeOPN transferases exhibit over 35 % protein identity to Cj1421 and all candidates contained homopolymeric tracts made up of 12-18 guanine residues. This indicates MeOPN expression in *C. upsaliensis* is also potentially regulated by phase variation.

1.4 Phosphate modifications of outer surface structures

PCho and MeOPN are two phosphorylated moieties that appear to be involved in the phase variable modification of *C. upsaliensis* LOS and CPS. As the outermost structures, the CPS and LOS dictate the initial physical interactions that *C. upsaliensis* undergoes with its host and environment. Therefore the biological functions of these substituents are integral to understanding the overall contribution of the outer surface of *C. upsaliensis* to pathogenesis.

1.4.1 PCho

The PCho moiety has been observed in a diverse range of organisms, including fungi, mammals, nematodes and bacteria. For nematodes, PCho is involved in human immune system modulation through the PCho-modified glycoprotein ES-62 (4, 33). ES-62 diverts the host immune system towards an anti-inflammatory phenotype by the down-regulation of MyD88 via interleukin-1 and toll-like receptor ligands (88). The immunoregulatory nature of ES-62 is so strong, it has been reported to provide protection against endotoxin and polymicrobial septic shock in an *in vivo* mouse model, without compromising immune system control of the bacterial infection (92).

PCho expression in bacteria occurs in the cell surface modifications of a variety of commensals and opportunistic pathogens present in the human oropharynx and nasopharynx mucosa (31, 119). Mucosal bacterial pathogens, such as *S. pneumoniae*, *Haemophilus* spp., and *Neisseria* spp., contain phase variable PCho modifications on their glycolipids (techoic acid, lipotechoic acid, LOS) and/or proteins (pilin).

C. upsaliensis RM3195 encodes a putative *licABCD* locus that in *H. influenzae*, is responsible for the modification of LOS with PCho. The role of each protein is as follows: LicB is responsible for the transport of extracellular choline into the bacteria (126). LicA and LicC synthesize PCho through the addition of a phosphate group to the choline by LicA and the activation of this PCho by the transfer of a nucleotide group. Finally, LicD transfers nucleotide-

activated PCho onto the LOS (126). The *H. influenzae* LOS structure is composed of a heptosyl trisaccharide inner core attached to the lipid A region through Kdo (102). Each heptose residue provides a substitution point for further chain extension. On HepI, it is invariably substituted with β -D-glucose, which can be extended with additional oligosaccharides (103). In every strain investigated to date, the HepII is substituted with phosphoethanolamine (25, 94, 102). The HepII can also be modified with an α -D-glucose, which can be extended by a trisaccharide in type b isolates, or in non-typeable strains, an oligosaccharide extension does not occur (66, 67, 97). The distal HepIII can be substituted with β -D-galactose or β -D-glucose, wherein β -D-glucose incorporation can result in further oligosaccharide chain extension (67). LicD transfers the PCho group to the O-6 position of the terminal β -D-galactose residue attached to HepIII. *H. influenzae* and *C. jejuni* do not have similar LOS compositions (77, 78, 80, 102). However based on the *C. upsaliensis* genome, its LOS biosynthetic locus has undergone considerable rearrangement with the incorporation of a number of novel genes, which may have altered *C. upsaliensis* LOS composition to enable LicD-mediated PCho decoration (23).

In a genetic screen of over 100 European and South African *C. upsaliensis* isolates, there was a strong association between the presence of the PCho biosynthetic locus and clinical symptoms (23). This indicates PCho expression is important for *C. upsaliensis* pathogenesis. In *H. influenzae* PCho-display is vital for its adherence and invasion (112). Non-typeable *H. influenzae* type b Eagan

demonstrated decreased adherence and invasion of a bronchial epithelial cell line by strains that did not exhibit a high reactivity to the antibody TEPC-15, a monoclonal antibody which is highly selective for the PCho epitope, as well as with an LOS core truncation mutant. The authors determined that *H. influenzae* exhibited PCho-dependent invasion through interaction with the host cell platelet activating factor receptor (PAFR). PCho-expressing *H. influenzae* co-localized with the PAFR, and pre-treatment of bronchial cells with a PAFR antagonist significantly inhibited invasion of these organisms (112).

Bacterial surface display of PCho mimics the natural ligand of PAFR, platelet activating factor (PAF) (112, 119). PAF is a proinflammatory chemokine and recognized by PAFR by its PCho group (64, 95, 106). Functional PAFR has been located on virtually every eukaryotic cell type, and can be detected on the host cell plasma membrane as well as in perinuclear and intranuclear regions (53, 64, 65). *H. influenzae*, *S. pneumoniae* and *Neisseria lactamica* all have been reported to utilize their PCho modified surface residues for cell invasion via PAFR (18, 105, 112, 113). *S. pneumoniae* PCho mutants were avirulent in a murine sepsis model and facilitated their own immunological clearance through activation of splenic dendritic cells (28). PAFR knockout mice as well as mice treated with a PAFR antagonist both presented reduced dissemination of infection, less pulmonary inflammation, as well as delayed and reduced mortality when infected with *S. pneumoniae* (96). A PCho-negative variant of *N. lactamica* demonstrated reduced adherence and invasion to epithelial cells compared to wild

type (105). This invasion was PCho-dependent, as measured by the decrease in wild type binding when cells were pretreated with TEPC-15, as well as PAFR-dependent, as exhibited by the approximately 60 % decrease in wild type invasion in the presence of 5 nM of PAFR antagonist (105).

Although PCho increases the virulence of these mucosal bacteria, it also increases their susceptibility to the bactericidal effects of human serum. This double-edge effect indicates a possible reason for the regulation of this moiety by phase variation. PCho is recognized by C-reactive protein (CRP), an acute-phase serum protein involved in the innate and adaptive immune responses. CRP binds bacteria via their PCho modified residues and marks them for subsequent uptake and phagocytosis by macrophages, or induces their clearance through C1q deposition and activation of complement by the classical pathway (15, 115, 120, 125, 126). The presence of PCho resulted in decreased serum survival of both *N. meningitidis* and *H. influenzae* compared to their PCho deletion mutants. (15, 125, 126). Pathogenic strains of *N. meningitidis* modify their pili with PCho, and the binding of CRP to PCho was concentration dependent and specific for CRP (15). CRP also acted as an opsonin for *N. meningitidis*, and bacterial phagocytosis by human macrophages and granulocytes was increased for the PCho-modified strain.

PCho display is a common strategy used by the bacterial communities in the respiratory mucosa. However, the potential modification of *C. upsaliensis* LOS with PCho is the first reported for an intestinal pathogen. It is unknown if

PCho display will provide *C. upsaliensis* with the same host cell invasion and serum phenotypes as described above.

1.4.2 MeOPN

The MeOPN modification is a unique, naturally-produced bacterial product that bears a close chemical structural resemblance to man-made pesticides (69, 70). The carbohydrate composition of CPS is highly variable, but approximately 70% of *C. jejuni* strains modify their CPS with phosphoramidate (MeOPN) (49, 70). MeOPN has been observed in a number of *C. jejuni* isolates and appears with a high prevalence among enteritis and Guillain Barré syndrome patient isolates (70). Currently there have been no studies conducted examining the contribution of MeOPN to human pathogenesis. A recent study however reported a MeOPN biosynthetic mutant demonstrated attenuated virulence in a *Galleria mellonella* wax moth pathogenesis model (16). This indicates that MeOPN may have a role as a virulence factor or a potential insecticide.

Interestingly, the MeOPN biosynthetic gene *cj1416* is homologous to the PCho biosynthetic gene *licC* suggesting that synthesis of MeOPN may also proceed through a nucleotide-linked intermediate (70). Like PCho, MeOPN appears to be involved in *C. jejuni* intestinal epithelial invasion, biofilm formation and serum resistance (van Alphen LB, personal communication). MeOPN also influences *C. jejuni* bacteriophage recognition, anti-fungal activity and insect mortality (107, 108, van Alphen LB, personal communication).

C. upsaliensis RM3195 encodes homologs of the MeOPN biosynthetic locus as well as multiple putative sugar transferases with high protein identity to Cj1421, the MeOPN transferase responsible for the addition of MeOPN to β -D-N-acetyl-galactosamine (70). A biological function for MeOPN in *C. upsaliensis* has not been described, although work on this modification in *C. jejuni* is ongoing in our lab. The function of MeOPN in *C. upsaliensis* may be similar to *C. jejuni*; however, the composition of the *C. upsaliensis* CPS is predicted to be unlike the CPS of *C. jejuni* due to the incorporation of the products from novel ORFs within the CPS biosynthetic loci of *C. upsaliensis* (23). This change in genome composition may result in differences in sugar composition and structure, altering the context by which MeOPN is presented to the environment and therefore altering its biological function.

1.5 Conclusions

C. upsaliensis has been linked to multiple cases of human disease, however studies concerning this emerging pathogen have been largely restricted to epidemiological identification. The susceptibility of *C. upsaliensis* to antibiotics routinely used in *Campylobacter* selective media may have aided in its obscurity. Our current understanding of this pathogen has lagged behind related pathogens *C. jejuni* and *C. coli*; and the clinical significance of *C. upsaliensis* to human illness requires examination at the level of its molecular virulence factors. *C. jejuni* and *C. upsaliensis* share a high degree of overall protein identity, but the *C. upsaliensis* genome has undergone massive rearrangements and incorporation

of novel genes that are predicted to impact its overall virulence and surface structure composition (23). Future studies aimed at the elucidation of the biological mechanism of *C. upsaliensis* putative virulence factors will provide insight into its pathogenicity and allow development of treatment and prevention strategies to reduce *C. upsaliensis*-mediated disease.

1.6 M.Sc. project objectives

The overarching goal of this research project was to address the deficiency in the literature concerning *C. upsaliensis* pathogenesis. More specifically, we aimed to identify and elucidate the function of PCho and MeOPN, and how these phosphorylated moieties impacted the interaction of *C. upsaliensis* with its surrounding environment. The biological roles of MeOPN have not been studied in detail and *C. upsaliensis* provided an interesting context for the study of this moiety because the organism also expresses the related phosphorylated residue, PCho. The function of PCho in other bacterial pathogens has been studied extensively, but this is the first report to our knowledge of an intestinal bacterial pathogen expressing PCho.

The first objective of this M.Sc. project was to genetically manipulate *C. upsaliensis*. In order to understand the contribution of both phosphorylated modifications in *C. upsaliensis* pathogenesis, mutants in the biosynthetic pathways needed to be constructed and then complemented. *C. upsaliensis* strain RM3195, the strain used in this study, contains extensive restriction modification systems as well as two plasmids that impact vector-based complementation, the

classical method for *Campylobacter* complementation (23). Successful complementation of *C. upsaliensis* requires the development of new genetic tools compared to the array of reagents currently available for *C. jejuni*.

Once the PCho and MeOPN mutants were created, a series of biological assays were applied to elucidate biological function(s). The role of PCho in the respiratory mucosal pathogens is well defined. PCho display marks bacteria for increased susceptibility to human serum through recognition by the acute phase pentraxin, C-reactive protein (112). Also, bacteria expressing PCho-modified glycans can hijack the platelet activating factor receptor through molecular mimicry of platelet activating factor, resulting in increased adherence and invasion of host cells (125). In *C. jejuni*, a MeOPN mutant demonstrated attenuated virulence in a *Galleria mellonella* pathogenesis model and preliminary results suggested a role for this modification in serum sensitivity and epithelial cell invasion (16, Dr. Lieke van Alphen personal communication). These results were used to direct the assays applied to the PCho and MeOPN *C. upsaliensis* mutants.

1.7 Literature cited

1. **Acke E, Whyte P, Jones BR, McGill K, Collins JD, Fanning S.** 2006. Prevalence of thermophilic *Campylobacter* species in cats and dogs in two animal shelters in Ireland. *Vet. Rec.* **158**:51-54.
2. **Alderton MR, Korolik V, Coloe PJ, Dewhirst FE, Paster BJ.** 1995. *Campylobacter hyoilei* sp. nov., associated with porcine proliferative enteritis. *Int. J. Syst. Bacteriol.* **45**:61-66.
3. **Allos BM.** 1997. Association between *Campylobacter* infection and Guillain-Barré syndrome. *J. Infect. Dis.* **176 S2**:S125-8.
4. **Al-Riyami L, Harnett W.** 2012. Immunomodulatory properties of ES-62, a phosphorylcholine-containing glycoprotein secreted by *Acanthocheilonema viteae*. *Endocr Metab. Immune Disord. Drug Targets.* **12**:45-52.
5. **Aspinall GO, Monteiro MA, Pang H.** 1995. Lipooligosaccharide of the *Campylobacter lari* type strain ATCC 35221. Structure of the liberated oligosaccharide and an associated extracellular polysaccharide. *Carbohydr. Res.* **279**:245-264.
6. **Aspinall ST, Wareing DRA, Hayward PG, Hutchinson DN.** 1993. Selective medium for thermophilic *Campylobacters* including *Campylobacter upsaliensis*. *J. Clin. Pathol.* **46**:829-831.
7. **Atanassova V, Ring C.** 1999. Prevalence of *Campylobacter* spp. in poultry and poultry meat in Germany. *Int. J. Food Microbiol.* **51**:187-190.
8. **Bacon DJ, Szymanski CM, Burr DH, Silver RP, Alm RA, Guerry P.** 2001. A phase-variable capsule is involved in virulence of *Campylobacter jejuni* 81-176. *Mol. Microbiol.* **40**:769-777.
9. **Beer W, Adam M, Seltmann G.** 1986. Monosaccharide composition of lipopolysaccharides from *Campylobacter jejuni* and *Campylobacter coli*. *J. Basic Microbiol.* **26**:201-204.
10. **Biswas D, Itoh K, Sasakawa C.** 2003. Role of microfilaments and microtubules in the invasion of INT-407 cells by *Campylobacter jejuni*. *Microbiol. Immunol.* **47**:469-473.
11. **Bourke B, Chan VL, Sherman P.** 1998. *Campylobacter upsaliensis*: Waiting in the wings. *Clin. Microbiol. Rev.* **11**:440-449.

12. **Bourke B, Sherman PM, Woodward D, Lior H, Chan VL.** 1996. Pulsed-field gel electrophoresis indicates genotypic heterogeneity among *Campylobacter upsaliensis* strains. FEMS Microbiol. Lett. **143**:57-61.
13. **Butzler JP.** 2004. *Campylobacter*, from obscurity to celebrity. Clin. Microbiol. Infect. **10**:868-876.
14. **Carter JE, Cimolai N.** 1996. Hemolytic-uremic syndrome associated with acute *Campylobacter upsaliensis* gastroenteritis. Nephron. **74**:489.
15. **Casey R, Newcombe J, McFadden J, Bodman-Smith KB.** 2008. The acute-phase reactant C-reactive protein binds to phosphorylcholine-expressing *Neisseria meningitidis* and increases uptake by human phagocytes. Infect. Immun. **76**:1298-1304.
16. **Champion OL, Karlyshev AV, Senior NJ, Woodward M, La Ragione R, Howard SL, Wren BW, Titball RW.** 2010. Insect infection model for *Campylobacter jejuni* reveals that *O*-methyl phosphoramidate has insecticidal Activity. J. Infect. Dis.
17. **Chusid MJ, Wortmann DW, Dunne WM.** 1990. "*Campylobacter upsaliensis*" sepsis in a boy with acquired hypogammaglobulinemia. Diagn. Microbiol. Infect. Dis. **13**:367-369.
18. **Cundell DR, Gerard NP, Gerard C, Idanpaan-Heikkila I, Tuomanen EI.** 1995. *Streptococcus pneumoniae* anchor to activated human cells by the receptor for platelet-activating factor. Nature. **377**:435-438.
19. **Damborg P, Guardabassi L, Pedersen K, Kokotovic B.** 2008. Comparative analysis of human and canine *Campylobacter upsaliensis* isolates by amplified fragment length polymorphism. J. Clin. Microbiol. **46**:1504-1506.
20. **Dorrell N, Mangan JA, Laing KG, Hinds J, Linton D, Al-Ghusein H, Barrell BG, Parkhill J, Stoker NG, Karlyshev AV, Butcher PD, Wren BW.** 2001. Whole genome comparison of *Campylobacter jejuni* human isolates using a low-cost microarray reveals extensive genetic diversity. Genome Res. **11**:1706-1715.
21. **Figura N.** 1991. *Campylobacter* spp. isolated from dog faeces. Lancet. **338**:1403.
22. **Figura N, Zanchi S, Partini N, Bugnoli M, Gugliemetti P, Signori R, Rossolini A.** 1993. *Campylobacters* of unusual species in Siena, Italy. Acta Gastro-Enterol. Belg. **56**:15.

23. **Fouts DE, Mongodin EF, Mandrell RE, Miller WG, Rasko DA, Ravel J, Brinkac LM, DeBoy RT, Parker CT, Daugherty SC, Dodson RJ, Durkin AS, Madupu R, Sullivan SA, Shetty JU, Ayodeji MA, Shvartsbeyn A, Schatz MC, Badger JH, Fraser CM, Nelson KE.** 2005. Major structural differences and novel potential virulence mechanisms from the genomes of multiple *Campylobacter* species. *PLoS Biol.* **3**:e15.
24. **Fox JG, Maxwell KO, Taylor NS, Runsick CD, Edmonds P, Brenner DJ.** 1989. "*Campylobacter upsaliensis*" isolated from cats as identified by DNA relatedness and biochemical features. *J. Clin. Microbiol.* **27**:2376-2378.
25. **Fox KL, Li J, Schweda EK, Vitiazeva V, Makepeace K, Jennings MP, Moxon ER, Hood DW.** 2008. Duplicate copies of *lic1* direct the addition of multiple phosphocholine residues in the lipopolysaccharide of *Haemophilus influenzae*. *Infect. Immun.* **76**:588-600.
26. **Fry BN, Feng S, Chen YY, Newell DG, Coloe PJ, Korolik V.** 2000. The *galE* gene of *Campylobacter jejuni* is involved in lipopolysaccharide synthesis and virulence. *Infect. Immun.* **68**:2594-2601.
27. **Gaudreau C, Lamothe F.** 1992. *Campylobacter upsaliensis* isolated from a breast abscess. *J. Clin. Microbiol.* **30**:1354-1356.
28. **Gehre F, Spisek R, Kharat AS, Matthews P, Kukreja A, Anthony RM, Dhodapkar MV, Vollmer W, Tomasz A.** 2009. Role of teichoic acid choline moieties in the virulence of *Streptococcus pneumoniae*. *Infect. Immun.* **77**:2824-2831.
29. **Gilbert M, Godschalk PCR, Parker CT, Endtz HP, Wakarchuk WW.** 2004. Genetic basis for the variation in the lipooligosaccharide outer core of *Campylobacter jejuni* and possible association of glycosyltransferase genes with post-infectious neuropathies, p. 219-248. *In* J. Ketley and M. E. Konkel (eds.), *Campylobacter jejuni: New perspectives in molecular and cellular biology*. Horizon Scientific Press, Norfolk, UK.
30. **Gilbert M, Parker CT, Moran AP.** 2008. *Campylobacter jejuni* lipooligosaccharides: Structure and biosynthesis, p. 483. *In* I. Nachamkin, C. M. Szymanski, and M. J. Blaser (eds.), *Campylobacter*, 3rd ed., . American Society for Microbiology, Washington, DC.
31. **Gillespie SH, Ainscough S, Dickens A, Lewin J.** 1996. Phosphorylcholine-containing antigens in bacteria from the mouth and respiratory tract. *J. Med. Microbiol.* **44**:35-40.

32. **Goddard, EA, Lastovica, AJ, Argent, AC.** 1997. *Campylobacter* 0:41 isolation in Guillain-Barre syndrome. *Arch. Dis. Child.* **76**:526-528.
33. **Goodridge HS, Marshall FA, Else KJ, Houston KM, Egan C, Al-Riyami L, Liew FY, Harnett W, Harnett MM.** 2005. Immunomodulation via novel use of TLR4 by the filarial nematode phosphorylcholine-containing secreted product, ES-62. *J. Immunol.* **174**:284-293.
34. **Goossens H, Giesendorf BA, Vandamme P, Vlaes L, Van den Borre C, Koeken A, Quint WG, Blomme W, Hanicq P, Koster DS.** 1995. Investigation of an outbreak of *Campylobacter upsaliensis* in day care centers in Brussels: Analysis of relationships among isolates by phenotypic and genotypic typing methods. *J. Infect. Dis.* **172**:1298-1305.
35. **Goossens H, Pot B, Vlaes L, Van den Borre C, Van den Abbeele R, Van Naelten C, Levy J, Cogniau H, Marbehant P, Verhoef J.** 1990. Characterization and description of "*Campylobacter upsaliensis*" isolated from human feces. *J. Clin. Microbiol.* **28**:1039-1046.
36. **Goossens H, Vlaes L, Butzler JP, Adnet A, Hanicq P, N'Jufom S, Massart D, de Schrijver G, Blomme W.** 1991. *Campylobacter upsaliensis* enteritis associated with canine infections. *Lancet.* **337**:1486-1487.
37. **Goossens H, Vlaes L, De Boeck M, Pot B, Kersters K, Levy J, De Mol P, Butzler JP, Vandamme P.** 1990. Is "*Campylobacter upsaliensis*" an unrecognized cause of human diarrhoea? *Lancet.* **335**:584-586.
38. **Grant CC, Konkel ME, Cieplak W Jr., Tompkins LS.** 1993. Role of flagella in adherence, internalization, and translocation of *Campylobacter jejuni* in nonpolarized and polarized epithelial cell cultures. *Infect. Immun.* **61**:1764-1771.
39. **Guerry P, Ewing CP, Hickey TE, Prendergast MM, Moran AP.** 2000. Sialylation of lipooligosaccharide cores affects immunogenicity and serum resistance of *Campylobacter jejuni*. *Infect. Immun.* **68**:6656-6662.
40. **Guerry P, Szymanski CM.** 2008. *Campylobacter* sugars sticking out. *Trends Microbiol.* **16**:428-435.
41. **Guerry P, Szymanski CM, Prendergast MM, Hickey TE, Ewing CP, Pattarini DL, Moran AP.** 2002. Phase variation of *Campylobacter jejuni* 81-176 lipooligosaccharide affects ganglioside mimicry and invasiveness in vitro. *Infect. Immun.* **70**:787-793.

42. **Gurgan T, Diker KS.** 1994. Abortion associated with *Campylobacter upsaliensis*. J. Clin. Microbiol. **32**:3093-3094.
43. **Henderson IR, Owen P, Nataro JP.** 1999. Molecular switches - The ON and OFF of bacterial phase variation. Mol. Microbiol. **33**:919-932.
44. **Hirschl AM, Pletschette M, Wolf D, Berger J, Diridl G, Rotter ML.** 1990. Frequency of occurrence and characterization of catalase negative *Campylobacter* isolated from human feces in Vienna. Zentralbl. Bakteriologie. **272**:547-553.
45. **Ho TW, Hsieh ST, Nachamkin I, Willison HJ, Sheikh K, Kiehlbauch J, Flanigan K, McArthur JC, Cornblath DR, McKhann GM, Griffin JW.** 1997. Motor nerve terminal degeneration provides a potential mechanism for rapid recovery in acute motor axonal neuropathy after *Campylobacter* infection. Neurology. **48**:717-724.
46. **Hu L, Kopecko DJ.** 1999. *Campylobacter jejuni* 81-176 associates with microtubules and dynein during invasion of human intestinal cells. Infect. Immun. **67**:4171-4182.
47. **Kanipes MI, Papp-Szabo E, Guerry P, Monteiro MA.** 2006. Mutation of *waaC*, encoding heptosyltransferase I in *Campylobacter jejuni* 81-176, affects the structure of both lipooligosaccharide and capsular carbohydrate. J. Bacteriol. **188**:3273-3279.
48. **Karlyshev AV, Champion OL, Churcher C, Brisson JR, Jarrell HC, Gilbert M, Brochu D, St Michael F, Li J, Wakarchuk WW, Goodhead I, Sanders M, Stevens K, White B, Parkhill J, Wren BW, Szymanski CM.** 2005. Analysis of *Campylobacter jejuni* capsular loci reveals multiple mechanisms for the generation of structural diversity and the ability to form complex heptoses. Mol. Microbiol. **55**:90-103.
49. **Karlyshev AV, Everest P, Linton D, Cawthraw S, Newell DG, Wren BW.** 2004. The *Campylobacter jejuni* general glycosylation system is important for attachment to human epithelial cells and in the colonization of chicks. Microbiology. **150**:1957-1964.
50. **Karlyshev AV, Ketley JM, Wren BW.** 2005. The *Campylobacter jejuni* glycome. FEMS Microbiol. Rev. **29**:377-390.
51. **Karlyshev AV, Linton D, Gregson NA, Lastovica AJ, Wren, BW.** 2000. Genetic and biochemical evidence of a *Campylobacter jejuni* capsular polysaccharide that accounts for Penner serotype specificity. Mol. Microbiol. **35**:529-541.

52. **Karlyshev AV, Wren BW, Moran AP.** 2008. *Campylobacter jejuni* capsular polysaccharide, p. 505-522. In I. Nachamkin, C. M. Szymanski, and M. J. Blaser (eds.), *Campylobacter*, 3rd ed., . American Society of Microbiology Press, Washington, DC, USA.
53. **Keely S, Glover LE, Weissmueller T, MacManus CF, Fillon S, Fennimore B, Colgan SP.** 2010. Hypoxia-inducible factor-dependent regulation of platelet-activating factor receptor as a route for Gram-positive bacterial translocation across epithelia. *Mol. Biol. Cell.* **21**:538-546.
54. **Kobayashi I.** 2001. Behavior of restriction-modification systems as selfish mobile elements and their impact on genome evolution. *Nucleic Acids Res.* **29**:3742-3756.
55. **Konkel ME, Klena JD, Rivera-Amill V, Monteville MR, Biswas D, Raphael B, Mickelson J.** 2004. Secretion of virulence proteins from *Campylobacter jejuni* is dependent on a functional flagellar export apparatus. *J. Bacteriol.* **186**:3296-3303.
56. **Labarca JA, Sturgeon J, Borenstein L, Salem N, Harvey SM, Lehnkering E, Reporter R, Mascola L.** 2002. *Campylobacter upsaliensis*: Another pathogen for consideration in the United States. *Clin. Infect. Dis.* **34**:E59-60.
57. **Labigne-Roussel A, Courcoux P, Tompkins L.** 1988. Gene disruption and replacement as a feasible approach for mutagenesis of *Campylobacter jejuni*. *J. Bacteriol.* **170**:1704-1708.
58. **Labigne-Roussel A, Harel J, Tompkins L.** 1987. Gene transfer from *Escherichia coli* to *Campylobacter* species: Development of shuttle vectors for genetic analysis of *Campylobacter jejuni*. *J. Bacteriol.* **169**:5320-5323.
59. **Lastovica AJ, Le Roux E, Penner JL.** 1989. "*Campylobacter upsaliensis*" isolated from blood cultures of pediatric patients. *J. Clin. Microbiol.* **27**:657-659.
60. **Leon MA, Young NM.** 1971. Specificity for phosphorylcholine of six murine myeloma proteins reactive with pneumococcus C polysaccharide and beta-lipoprotein. *Biochemistry.* **10**:1424-1429.
61. **Lindblom GB, Sjogren E, Hansson-Westerberg J, Kaijser B.** 1995. *Campylobacter upsaliensis*, *C. sputorum sputorum* and *C. concisus* as common causes of diarrhoea in Swedish children. *Scand. J. Infect. Dis.* **27**:187-188.
62. **Linton D, Gilbert M, Hitchen PG, Dell A, Morris HR, Wakarchuk WW, Gregson NA, Wren BW.** 2000. Phase variation of a beta-1,3

galactosyltransferase involved in generation of the ganglioside GM1-like lipooligosaccharide of *Campylobacter jejuni*. Mol. Microbiol. **37**:501-514.

63. **Lynch OA, Cagney C, McDowell DA, Duffy G.** 2011. Occurrence of fastidious *Campylobacter* spp. in fresh meat and poultry using an adapted cultural protocol. Int. J. Food Microbiol. **150**:171-177.

64. **Marrache AM, Gobeil F Jr, Bernier SG, Stankova J, Rola-Pleszczynski M, Choufani S, Bkaily G, Bourdeau A, Sirois MG, Vazquez-Tello A, Fan L, Joyal JS, Filep JG, Varma DR, Ribeiro-Da-Silva A, Chemtob, S.** 2002. Proinflammatory gene induction by platelet-activating factor mediated via its cognate nuclear receptor. J. Immunol. **169**:6474-6481.

65. **Marrache AM, Gobeil F, Zhu T, Chemtob S.** 2005. Intracellular signaling of lipid mediators via cognate nuclear G protein-coupled receptors. Endothelium. **12**:63-72.

66. **Masoud H, Martin A, Thibault P, Moxon ER, Richards JC.** 2003. Structure of extended lipopolysaccharide glycoforms containing two globotriose units in *Haemophilus influenzae* serotype b strain RM7004. Biochemistry. **42**:4463-4475.

67. **Masoud, H, Moxon, ER, Martin, A, Krajcarski, D, Richards, JC.** 1997. Structure of the variable and conserved lipopolysaccharide oligosaccharide epitopes expressed by *Haemophilus influenzae* serotype b strain Eagan. Biochemistry. **36**:2091-2103. doi: 10.1021/bi961989y.

68. **McNally DJ, Jarrell HC, Khieu NH, Li J, Vinogradov E, Whitfield DM, Szymanski CM, Brisson JR.** 2006. The HS:19 serostrain of *Campylobacter jejuni* has a hyaluronic acid-type capsular polysaccharide with a nonstoichiometric sorbose branch and *O*-methyl phosphoramidate group. FEBS J. **273**:3975-3989.

69. **McNally DJ, Jarrell HC, Li J, Khieu NH, Vinogradov E, Szymanski CM, Brisson JR.** 2005. The HS:1 serostrain of *Campylobacter jejuni* has a complex teichoic acid-like capsular polysaccharide with nonstoichiometric fructofuranose branches and *O*-methyl phosphoramidate groups. FEBS J. **272**:4407-4422.

70. **McNally DJ, Lamoureux MP, Karlyshev AV, Fiori LM, Li J, Thacker G, Coleman RA, Khieu NH, Wren BW, Brisson JR, Jarrell HC, Szymanski CM.** 2007. Commonality and biosynthesis of the *O*-methyl phosphoramidate capsule modification in *Campylobacter jejuni*. J. Biol. Chem. **282**:28566-28576.

71. **McSweegan E, Walker RI.** 1986. Identification and characterization of two *Campylobacter jejuni* adhesins for cellular and mucous substrates. *Infect. Immun.* **53**:141-148.
72. **Megraud F, Bonnet F.** 1986. Unusual *Campylobacters* in human faeces. *J. Infect.* **12**:275-276.
73. **Mills SD, Kurjanczyk LA, Penner JL.** 1988. Identification of an antigen common to different species of the genus *Campylobacter*. *J. Clin. Microbiol.* **26**:1411-1413.
74. **Monteville MR, Yoon JE, Konkell ME.** 2003. Maximal adherence and invasion of INT 407 cells by *Campylobacter jejuni* requires the CadF outer-membrane protein and microfilament reorganization. *Microbiology.* **149**:153-165.
75. **Mooney A, Byrne C, Clyne M, Johnson-Henry K, Sherman P, Bourke B.** 2003. Invasion of human epithelial cells by *Campylobacter upsaliensis*. *Cell. Microbiol.* **5**:835-847.
76. **Mooney A, Clyne M, Curran T, Doherty D, Kilmartin B, Bourke B.** 2001. *Campylobacter upsaliensis* exerts a cytolethal distending toxin effect on HeLa cells and T lymphocytes. *Microbiology.* **147**:735-743.
77. **Moran AP.** 1995. Biological and serological characterization of *Campylobacter jejuni* lipopolysaccharides with deviating core and lipid A structures. *FEMS Immunol. Med. Microbiol.* **11**:121-130.
78. **Moran AP.** 1997. Structure and conserved characteristics of *Campylobacter jejuni* lipopolysaccharides. *J. Infect. Dis.* **176 S2**:S115-21.
79. **Moran AP, O'Malley DT, Kosunen TU, Helander IM.** 1994. Biochemical characterization of *Campylobacter fetus* lipopolysaccharides. *Infect. Immun.* **62**:3922-3929.
80. **Moran AP, Rietschel ET, Kosunen TU, Zahringer U.** 1991. Chemical characterization of *Campylobacter jejuni* lipopolysaccharides containing N-acetylneuraminic acid and 2,3-diamino-2,3-dideoxy-D-glucose. *J. Bacteriol.* **173**:618-626.
81. **Moreno GS, Griffiths PL, Connerton IF, Park RW.** 1993. Occurrence of *Campylobacters* in small domestic and laboratory animals. *J. Appl. Bacteriol.* **75**:49-54.

82. Moser I, Rieksneuwohner B, Lentzsch P, Schwerk P, Wieler LH. 2001. Genomic heterogeneity and O-antigenic diversity of *Campylobacter upsaliensis* and *Campylobacter helveticus* strains isolated from dogs and cats in Germany. J. Clin. Microbiol. **39**:2548-2557.
83. Newell DG, McBride H, Dolby JM. 1985. Investigations on the role of flagella in the colonization of infant mice with *Campylobacter jejuni* and attachment of *Campylobacter jejuni* to human epithelial cell lines. J. Hyg. (Lond). **95**:217-227.
84. Parkhill J, Wren BW, Mungall K, Ketley JM, Churcher C, Basham D, Chillingworth T, Davies RM, Feltwell T, Holroyd S, Jagels K, Karlyshev AV, Moule S, Pallen MJ, Penn CW, Quail MA, Rajandream MA, Rutherford KM, van Vliet AH, Whitehead S, Barrell BG. 2000. The genome sequence of the food-borne pathogen *Campylobacter jejuni* reveals hypervariable sequences. Nature. **403**:665-668.
85. Patton, CM, Shaffer, N, Edmonds, P, Barrett, TJ, Lambert, MA, Baker, C, Perlman, DM, Brenner, DJ. 1989. Human disease associated with "*Campylobacter upsaliensis*" (catalase-negative or weakly positive *Campylobacter* species) in the United States. J. Clin. Microbiol. **27**:66-73.
86. Penner JL. 1988. The genus *Campylobacter*: A decade of progress. Clin. Microbiol. Rev. **1**:157-172.
87. Pickett CL, Pesci EC, Cottle DL, Russell G, Erdem AN, Zeytin H. 1996. Prevalence of cytolethal distending toxin production in *Campylobacter jejuni* and relatedness of *Campylobacter* sp. *cdtB* gene. Infect. Immun. **64**:2070-2078.
88. Pineda MA, McGrath MA, Smith PC, Al-Riyami L, Rzepecka J, Gracie JA, Harnett W, Harnett MM. 2012. The parasitic helminth product ES-62 suppresses pathogenesis in CIA by targeting of the IL-17-producing cellular network at multiple sites. Arthritis Rheum.
89. Poly F, Read TD, Chen YH, Monteiro MA, Serichantalergs O, Pootong P, Bodhidatta L, Mason CJ, Rockabrand D, Baqar S, Porter CK, Tribble D, Darsley M, Guerry P. 2008. Characterization of two *Campylobacter jejuni* strains for use in volunteer experimental-infection studies. Infect. Immun. **76**:5655-5667.
90. Prendergast MM, Moran AP. 2000. Lipopolysaccharides in the development of the Guillain-Barré syndrome and Miller Fisher syndrome forms of acute inflammatory peripheral neuropathies. J. Endotoxin Res. **6**:341-359.

91. **Preston A, Mandrell RE, Gibson BW, Apicella MA.** 1996. The lipooligosaccharides of pathogenic Gram-negative bacteria. *Crit. Rev. Microbiol.* **22**:139-180.
92. **Puneet P, McGrath MA, Tay HK, Al-Riyami L, Rzepecka J, Moochhala SM, Pervaiz S, Harnett MM, Harnett W, Melendez AJ.** 2011. The helminth product ES-62 protects against septic shock via Toll-like receptor 4-dependent autophagosomal degradation of the adaptor MyD88. *Nat. Immunol.* **12**:344-351.
93. **Raetz CR, Whitfield C.** 2002. Lipopolysaccharide endotoxins. *Annu. Rev. Biochem.* **71**:635-700.
94. **Richards JC, Cox AD, Schweda EK, Martin A, Hood DW, Moxon ER.** 2001. Structure and functional genomics of lipopolysaccharide expression in *Haemophilus influenzae*. *Adv. Exp. Med. Biol.* **491**:515-524.
95. **Richardson RM, Marjoram RJ, Barr AJ, Snyderman R.** 2001. RGS4 inhibits platelet-activating factor receptor phosphorylation and cellular responses. *Biochemistry.* **40**:3583-3588.
96. **Rijneveld AW, Weijer S, Florquin S, Speelman P, Shimizu T, Ishii S, van der Poll T.** 2004. Improved host defense against pneumococcal pneumonia in platelet-activating factor receptor-deficient mice. *J. Infect. Dis.* **189**:711-716.
97. **Risberg A, Masoud H, Martin A, Richards JC, Moxon ER, Schweda EK.** 1999. Structural analysis of the lipopolysaccharide oligosaccharide epitopes expressed by a capsule-keficient strain of *Haemophilus influenzae*. *Rd. Eur. J. Biochem.* **261**:171-180.
98. **Roop RM 2nd, Smibert RM, Johnson JL, Krieg NR.** 1985. DNA homology studies of the catalase-negative *Campylobacters* and "*Campylobacter fecalis*," an emended description of *Campylobacter sputorum*, and proposal of the neotype strain of *Campylobacter sputorum*. *Can. J. Microbiol.* **31**:823-831.
99. **Rose A, Kay E, Wren BW, Dallman MJ.** 2011. The *Campylobacter jejuni* NCTC11168 capsule prevents excessive cytokine production by dendritic cells. *Med. Microbiol. Immunol.*
100. **Sandstedt K, Ursing J.** 1991. Description of *Campylobacter upsaliensis* sp nov previously Known as the CNW group. *Syst. Appl. Microbiol.* **14**:39-45.
101. **Sandstedt K, Ursing J, Walder M.** 1983. Thermotolerant *Campylobacter* with no or weak catalase activity isolated from dogs. *Curr. Microbiol.* **8**:209-213.

102. Schweda EK, Brisson JR, Alvelius G, Martin A, Weiser JN, Hood DW, Moxon ER, Richards JC. 2000. Characterization of the phosphocholine-substituted oligosaccharide in lipopolysaccharides of type b *Haemophilus influenzae*. Eur. J. Biochem. **267**:3902-3913.
103. Schweda EK, Li J, Moxon ER, Richards JC. 2002. Structural analysis of lipopolysaccharide oligosaccharide epitopes expressed by non-typeable *Haemophilus influenzae* strain 176. Carbohydr. Res. **337**:409-420.
104. Serino L, Virji M. 2000. Phosphorylcholine decoration of lipopolysaccharide differentiates commensal *Neisseriae* from pathogenic strains: identification of *licA*-type genes in commensal *Neisseriae*. Mol. Microbiol. **35**:1550-1559.
105. Serino L, Virji M. 2002. Genetic and functional analysis of the phosphorylcholine moiety of commensal *Neisseria* lipopolysaccharide. Mol. Microbiol. **43**:437-448.
106. Snyder F. 1990. Platelet-activating factor and related acetylated lipids as potent biologically active cellular mediators. Am. J. Physiol. **259**:C697-708.
107. Sorensen MCH, van Alphen LB, Fodor C, Crowley SM, Christensen BB, Szymanski CM, Brondsted L. 2012. Phase variable expression of capsular polysaccharide modifications allows *Campylobacter jejuni* to avoid bacteriophage infection in chickens. Front. Cell. and Infect. Microbiol. **2**: e.
108. Sorensen MC, van Alphen LB, Harboe A, Li J, Christensen BB, Szymanski CM, Brondsted L. 2011. Bacteriophage F336 recognizes the capsular phosphoramidate modification of *Campylobacter jejuni* NCTC11168. J. Bacteriol. **193**:6742-6749.
109. St Michael F, Szymanski CM, Li J, Chan KH, Khieu NH, Larocque S, Wakarchuk WW, Brisson JR, Monteiro MA. 2002. The structures of the lipooligosaccharide and capsule polysaccharide of *Campylobacter jejuni* genome sequenced strain NCTC 11168. Eur. J. Biochem. **269**:5119-5136.
110. Stanley J, Jones C, Burnens A, Owen RJ. 1994. Distinct genotypes of human and canine isolates of *Campylobacter upsaliensis* determined by 16S rRNA gene typing and plasmid profiling. J. Clin. Microbiol. **32**:1788-1794.
111. Steele TW, Sangster N, Lanser JA. 1985. DNA relatedness and biochemical features of *Campylobacter* spp isolated in Central Australia and South Australia. J. Clin. Microbiol. **22**:71-74.

112. **Swords WE, Buscher BA, Ver Steeg Ii K, Preston A, Nichols WA, Weiser JN, Gibson BW, Apicella MA.** 2000. Non-typeable *Haemophilus influenzae* adhere to and invade human bronchial epithelial cells via an interaction of lipooligosaccharide with the PAF receptor. *Mol. Microbiol.* **37**:13-27.
113. **Swords WE, Ketterer MR, Shao J, Campbell CA, Weiser JN, Apicella MA.** 2001. Binding of the non-typeable *Haemophilus influenzae* lipooligosaccharide to the PAF receptor initiates host cell signalling. *Cell. Microbiol.* **3**:525-536.
114. **Sylvester FA, Philpott D, Gold B, Lastovica A, Forstner JF.** 1996. Adherence to lipids and intestinal mucin by a recently recognized human pathogen, *Campylobacter upsaliensis*. *Infect. Immun.* **64**:4060-4066.
115. **Szalai AJ, Agrawal A, Greenhough TJ, Volanakis JE.** 1997. C-reactive protein: Structural biology, gene expression, and host defense function. *Immunol. Res.* **16**:127-136.
116. **Szymanski CM, Armstrong GD.** 1996. Interactions between *Campylobacter jejuni* and lipids. *Infect. Immun.* **64**:3467-3474.
117. **Szymanski CM, Michael FS, Jarrell HC, Li J, Gilbert M, Larocque S, Vinogradov E, Brisson JR.** 2003. Detection of conserved N-linked glycans and phase-variable lipooligosaccharides and capsules from campylobacter cells by mass spectrometry and high resolution magic angle spinning NMR spectroscopy. *J. Biol. Chem.* **278**:24509-24520.
118. **Taylor DE, Hiratsuka K, Mueller L.** 1989. Isolation and characterization of catalase-negative and catalase-weak strains of campylobacter species, including *Campylobacter upsaliensis*, from humans with gastroenteritis. *J. Clin. Microbiol.* **27**:2042-2045.
119. **Thornton JA, Durick-Eder K, Tuomanen EI.** 2010. Pneumococcal pathogenesis: "Innate invasion" yet organ-specific damage. *J. Mol. Med. (Berl).* **88**:103-107.
120. **Volanakis JE, Kaplan MH.** 1974. Interaction of C-reactive protein complexes with the complement system. II. Consumption of guinea pig complement by CRP complexes: requirement for human C1q. *J. Immunol.* **113**:9-17.
121. **Walmsley SL, Karmali MA.** 1989. Direct isolation of atypical thermophilic *Campylobacter* species from human feces on selective agar medium. *J. Clin. Microbiol.* **27**:668-670.

122. **Wassenaar TM, Bleumink-Pluym NM, van der Zeijst BA.** 1991. Inactivation of *Campylobacter jejuni* flagellin genes by homologous recombination demonstrates that *flaA* but not *flaB* is required for invasion. *EMBO J.* **10**:2055-2061.
123. **Watson RO, Galan JE.** 2008. *Campylobacter jejuni* survives within epithelial cells by avoiding delivery to lysosomes. *PLoS Pathog.* **4**:e14.
124. **Weiser JN, Love JM, Moxon ER.** 1989. The molecular mechanism of phase variation of *Haemophilus influenzae* lipopolysaccharide. *Cell.* **59**:657-665.
125. **Weiser JN, Pan N, McGowan KL, Musher D, Martin A, Richards J.** 1998. Phosphorylcholine on the lipopolysaccharide of *Haemophilus influenzae* contributes to persistence in the respiratory tract and sensitivity to serum killing mediated by C-reactive protein. *J. Exp. Med.* **187**:631-640.
126. **Weiser JN, Shchepetov M, Chong ST.** 1997. Decoration of lipopolysaccharide with phosphorylcholine: A phase-variable characteristic of *Haemophilus influenzae*. *Infect. Immun.* **65**:943-950.
127. **Westgarth C, Porter CJ, Nicolson L, Birtles RJ, Williams NJ, Hart CA, Pinchbeck GL, Gaskell RM, Christley RM, Dawson S.** 2009. Risk factors for the carriage of *Campylobacter upsaliensis* by dogs in a community in Cheshire. *Vet. Rec.* **165**:526-530.

CHAPTER 2

The genetic manipulation of *Campylobacter upsaliensis* and the development of vector systems for complementation

(The analysis and creation of Figure 2.1 was done by Dr. William Miller at the
United States Department of Agriculture)

2.1 Introduction

Campylobacter upsaliensis is an emerging human pathogen that clinical studies have linked to illnesses such as self-limiting gastroenteritis, hemolytic-uremic syndrome, Guillain-Barré syndrome and extra-intestinal infections of the breast and placenta (2, 5, 7, 14, 19). The virulence factors associated with *C. upsaliensis* disease are unclear, but with the recent publication of two *C. upsaliensis* genomes; homology searches and genetic manipulation can be used to study the molecular determinants of its pathogenicity (13).

As the outermost structures, the capsular polysaccharides (CPS) and lipooligosaccharides (LOS) dictate the initial physical interactions *C. upsaliensis* undergoes with its host and environment. CPS and LOS are integral to host cell invasion, serum survival and pathogenesis in animal models for *Campylobacter jejuni*, the best characterized species of *Campylobacter* (4, 8, 17, 18, 22, 38, 42). Both of these complex carbohydrates are subject to variable non-carbohydrate modification including the addition of phosphorylated structures. The carbohydrate composition of the CPS is highly variable, but approximately 70% of *C. jejuni* strains modify their CPS with phosphoramidate (MeOPN) and the biosynthetic locus appears to be highly conserved among the *Campylobacter* genus (Figure 2.1) (23, 32). MeOPN-decorated CPS was highly prevalent among *C. jejuni* isolates recovered from enteritis, Guillain Barré syndrome or Miller-Fisher syndrome patients, and a MeOPN biosynthetic mutant demonstrated attenuated virulence in a *Galleria mellonella* insect pathogenesis model (8, 32).

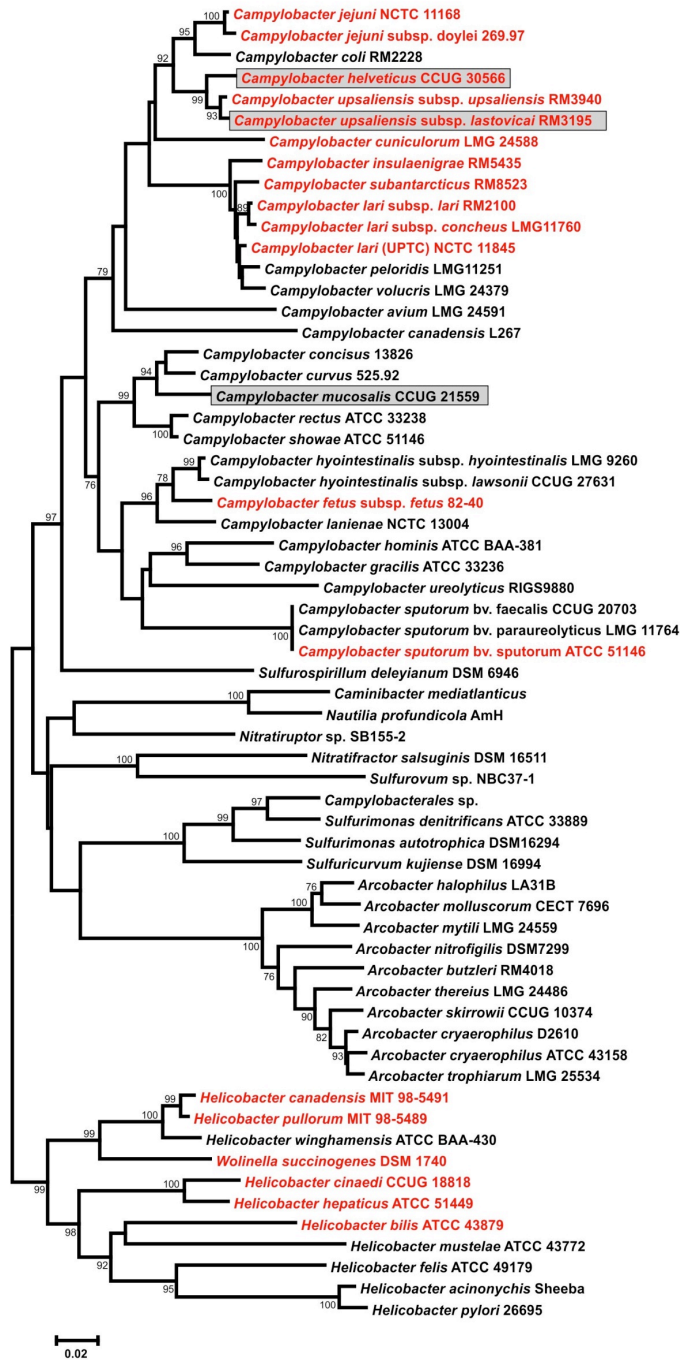

Figure 2.1 Dendrogram of Epsilonproteobacterial AtpA amino acid sequences. AtpA protein sequences were extracted from the draft or completed Epsilonproteobacterial genome sequences for taxa illustrated in the tree. The

dendrogram was constructed by Dr. William Miller at the Agriculture Research Service, United States Department of Agriculture using a neighbor-joining algorithm and the Poisson distance estimation method. Bootstrap values of >75%, generated from 500 replicates, are shown at the nodes. The scale bar represents substitutions per site. Genomes labeled in red contain orthologs of the MeOPN biosynthesis genes *cj1416-1418*, and genomes shaded in gray contain the *licABCD* phosphocholine locus.

In addition to MeOPN, other phosphate-containing modifications have been implicated in decorating *Campylobacter* surface structures. In a genetic screen of over 100 European and South African *C. upsaliensis* isolates, there was a strong association between the presence of phosphocholine (PCho) biosynthetic genes and clinical symptoms (13). PCho is less prevalent among the *Campylobacters* (Figure 2.1), but multiple pathogens such as *Streptococcus pneumoniae*, *Haemophilus* spp. and *Neisseria* spp., modify their glycolipids (teichoic acid, lipoteichoic acid or LOS) and/or proteins with PCho, and these modification are important for their pathogenesis (51).

Interestingly, similar protein functions exist between the different biosynthetic pathways for the generation of these phosphorylated modifications. *C. jejuni* MeOPN biosynthetic protein Cj1416 demonstrates a 32% protein identity to LicC, a cytidylyltransferase involved in the biosynthesis of PCho (32).

This also suggests that compensation or “cross-talk” could occur between these biosynthetic pathways, but to date has not been explored.

Despite extensive epidemiological evidence correlating *C. upsaliensis* with disease, there are limited studies that explore its pathogenesis, and to our knowledge, there are no reports of the genetic manipulation *C. upsaliensis* to explore its possible virulence mechanisms. A causal relationship between a gene product and bacterial pathogenesis can be established through the experimental criteria outlined in the molecular Koch postulates (11). To determine if a gene is a virulence factor, it must be specifically inactivated to elucidate if this disruption results in a measurable loss of pathogenicity (11). The marker rescue technique has been used to address this criterion in multiple different genera of bacteria, and was first used to mutate *C. jejuni* in 1988 (28, 33). This method involves the interruption of a gene via insertion of an antibiotic resistance cassette. Then the mutant is selected by subjecting the entire bacterial population to the antibiotic in which the mutant encodes resistance. *Campylobacter* is naturally transformable, but foreign DNA can also be introduced via electroporation or conjugation (29, 33, 53, 54).

Despite the capacity to readily create mutants in select *Campylobacter* strains, the ability to complement them can be problematic. There are a variety of shuttle vectors and genomic integration vectors available for *C. jejuni*, but none have been used in *C. upsaliensis*, and uptake of these vectors and subsequent expression of the re-introduced gene has been met with variable success in *C.*

jejuni (1, 34, 35, 41, 57). Even in the widely used *C. jejuni* genome sequenced strain, NCTC 11168, extensive differences in the ability to complement have been reported. Karlyshev and Wren were unable to introduce any of the commonly used shuttle vectors including pRY112, pMW10, pGUO0202 and pMEK91 into *C. jejuni* NCTC 11168 after repeated electroporation and natural transformation attempts (24). Other laboratories do not appear to experience this setback and routinely employ the pMW and pRY vector derivatives for NCTC 11168 complementation (39, 47).

Many protocols and constructs are available for mutation and complementation of *C. jejuni*. However, the application of these genetic tools to *C. upsaliensis* has never been attempted. In this section, the construction of the first insertional mutants in *C. upsaliensis* via the addition of a chloramphenicol resistance cassette is described. Utilizing this strategy we confirm that *Cup_0802* and *licC* are required for the biosynthesis of MeOPN and PCho, respectively. Multiple complementation vectors from *C. jejuni* are tested alongside four *C. upsaliensis*-based vectors constructed in this study, but none are retained in either the *C. upsaliensis* mutants or wildtype.

2.2 Material and methods

2.2.1 Bacterial strains and growth conditions

The bacterial strains used in this study are listed in Table 2.1. The *C. upsaliensis* strain RM3195 (ATCC BAA-1059, Manassas, VA, USA) was originally obtained from the feces of a 4-year-old Guillain-Barré patient and its

genome later sequenced by Fouts and colleagues (13). All *C. upsaliensis* strains were routinely grown on Blood Agar Base No. 2 (Oxoid, Basingstoke, Hampshire, UK) which was supplemented with 7 % Horse Blood (Quadfive, Ryegate, MT) and 1 % Yeast Extract (BD/Bacto, Franklin Lakes, NJ, USA). All *C. upsaliensis* strains were grown at 37°C under microaerobic conditions (85 % N₂, 10 % CO₂ and 5% O₂). All *Escherichia coli* strains were grown in LB broth (BD/Bacto) or on LB plates containing 1.5 % agar (BD/Bacto). Chloramphenicol (Cm), ampicillin (Amp), tetracycline (Tet) and kanamycin (Km) (Sigma-Aldrich, Oakville, ON) were supplemented when necessary at a final concentration of 20µg ml⁻¹, 100µg ml⁻¹, 50µg ml⁻¹ and 25µg ml⁻¹, respectively.

Table 2.1 Strains and plasmids used in this study.

Plasmid/Strain	Description	Reference or source
<i>Plasmid</i>		
pGEM-t Easy	TA cloning vector; Amp ^R	Promega
pGEM-t Easy:: <i>licC</i>	<i>licC</i> in pGEM-t Easy	This study
pGEM-t Easy:: <i>Cup_0802</i>	<i>Cup_0802</i> in pGEM-t Easy	This study
pRY109	<i>C. jejuni/E. coli</i> expression vector; Cm ^R	(57)
<i>plicC::cat</i>	Cm ^R from pRY109 interrupt <i>licC</i>	This study
<i>pCup_0802::cat</i>	Cm ^R from pRY109 interrupt <i>Cup_0802</i>	This study
<i>plicC::aphA-3</i>	Km ^R from pWM1007 interrupt <i>licC</i>	This study
<i>pCup_0802::aphA-3</i>	Km ^R from pWM1007 interrupt <i>licC</i>	This study
pCE107/70	<i>C. jejuni/E. coli</i> expression vector derived from pRY107, with a σ^{70} promoter from <i>cj1291</i> at MCS, Km ^R	(30)
pWM1007	<i>C. jejuni/E. coli</i> expression vector; Km ^R , GFP	(34)
pRRK	<i>C. jejuni</i> genomic integration vector, Km ^R , inserts between <i>rrs</i> and <i>rrl</i> (region between 16S and 28S rRNAs)	(24)
pCE107/70:: <i>Cup_0802</i>	<i>Cup_0802</i> in pCE107/70	This study
pCE107/70:: <i>licC</i>	<i>licC</i> in pCE107/70	This study
pWM1007:: <i>Cup_0802</i>	<i>Cup_0802</i> in pWM1007	This study
pWM1007:: <i>licC</i>	<i>licC</i> in pWM1007	This study
pRRK:: <i>Cup_0802</i>	<i>Cup_0802</i> in pRRK	This study
pRRK:: <i>licC</i>	<i>licC</i> in pRRK	This study
pSC101	<i>Cup_0016</i> to <i>Cup_0019</i> in pGEM-t Easy	This study
pSC102	XbaI site inserted between <i>Cup_0016</i> and <i>Cup_0017</i>	This study
pSC103	Oligonucleotide inserted between <i>Cup_0016</i> and <i>Cup_0017</i>	This study
pSC1	<i>C. upsaliensis</i> integration vector; Km ^R , <i>cat</i> promoter regulating MCS, inserts into intergenic region between <i>Cup_0016</i> and <i>Cup_0017</i>	This study
pSC1:: <i>Cup_0802</i>	<i>Cup_0802</i> in pSC1	This study
pSC1:: <i>licC</i>	<i>licC</i> in pSC1	This study
pSC101L	<i>Cup_0014</i> to <i>Cup_0019</i> in pGEM-t Easy	This study

pSC102L	XbaI site inserted between <i>Cup_0016</i> and <i>Cup_0017</i>	This study
pSC103L	Oligonucleotide inserted between <i>Cup_0016</i> and <i>Cup_0017</i>	This study
pSC1L	<i>C. upsaliensis</i> integration vector; Km ^R , <i>cat</i> promoter regulating MCS, inserts into intergenic region between <i>Cup_0016</i> and <i>Cup_0017</i> with longer flanking regions	This study
pSC1L:: <i>Cup_0802</i>	<i>Cup_0802</i> in pSC1L	This study
pSC1L:: <i>licC</i>	<i>licC</i> in pSC1L	This study
pSC201	<i>Cup_0666</i> to <i>Cup_0672</i> in pGEM-t Easy	This study
pSC202	XbaI site inserted in <i>Cup_0668</i> and <i>Cup_0669</i>	This study
pSC203	Oligonucleotide inserted, deleting <i>Cup_0668</i> and <i>Cup_0669</i>	This study
pSC2	<i>C. upsaliensis</i> integration vector; Km ^R , <i>cat</i> promoter regulating MCS, deletes pseudogenes <i>Cup_0668</i> and <i>Cup_0669</i>	This study
pSC2:: <i>Cup_0802</i>	<i>Cup_0802</i> in pSC2	This study
pSC2:: <i>licC</i>	<i>licC</i> in pSC2	This study
pSC3	p3195-1 in pGEM-t Easy	This study
pSC4	p3195-1 with Km ^R cassette from pWM1007	This study
<i>C. upsaliensis</i>		
RM3195 wt	Clinical isolate	(13)
RM3195 <i>licC</i> :: <i>cat</i>	RM3195; <i>licC</i> mutant, Cm ^R	This study
RM3195 <i>Cup_0802</i> :: <i>cat</i>	RM3195; <i>CUP_0802</i> mutant, Cm ^R	This study
<i>E. coli</i>		
DH5α	F ⁻ <i>endA1 hsdR17 supE44 thi-1 recA1 Δ (argF-lacZYA)U169 (80d lacZ Δ M15) gyrA96 λ</i>	Invitrogen
JM110	<i>rpsL (Str^R) thr leu thi-1 lacY galK galT ara tonA tsx dam dcm supE44 Δ(lac-proAB) [F' traD36 proAB lacI^qZΔM15]</i>	ATCC

*Amp^R, ampicillin resistance; Cm^R, chloramphenicol resistance; Km^R, kanamycin resistance; Tet^R, tetracycline resistance; Str^R, streptomycin resistance.

2.2.2 PCR

Oligonucleotides were manufactured by Integrated DNA Technologies (Coralville, IA) and are listed in Table 2.2. PCR was performed with 300-500 ng of template DNA, 100 nM primer, 1.0 U of Vent polymerase (New England Biosciences (NEB), Ipswich, MA), 1 X ThermoPol Reaction Buffer (NEB), 2 mM MgSO₄ (NEB), and 200 μM deoxynucleoside triphosphate mix (Fermentas, Burlington, ON). The cycling program consisted of an initial denaturation step of 3 min at 95 °C, followed by 30 - 35 cycles of 1 min at 95 °C, 1 min at 55 - 60 °C, and 30 s - 5 min at 72 °C, with a final 7 min extension at 72 °C. Extension time varied with the length of DNA fragment to be amplified, (time was set at 1 kb per 1 min) and annealing temperature was adjusted to address calculated primer pair melting temperature.

Table 2.2 Oligonucleotides used in this study.

Oligonucleotide	Sequence 5'-3'	Target
licCF	GGA CCT GTG GCG ATG TAT TG	<i>licC</i> (forward)
licCR	TTG CAT CGC TGT ATG TCA AG	<i>licC</i> (reverse)
Cup_0802F	CCT ATG GTG CTA ACG ACT TTG G	<i>Cup_0802</i> (forward)
Cup_0802R	CGG GAT CCG ACT TCA ACA CGC CAA ATA AGC	<i>Cup_0802</i> (reverse)
licCoutF	GCG GAT CCT GCT AAG GG GAG TGG TAT	Insertion of BamHI site in pGEM-t Easy:: <i>licC</i> (forward)
licCoutR	CGG GAT CCA AAG GAT GGT TCG CTC TAT G	Insertion of BamHI site in pGEM-t Easy:: <i>licC</i> (reverse)
Cup_0802outF	CGG GAT CCG ACT TCA ACA CGC CAA ATA AGC	Insertion of BamHI site in pGEM-t Easy:: <i>Cup_0802</i> (forward)
Cup_0802outR	CGG GAT CCA AGT CTC ACA TCG ACA TAA GG	Insertion of BamHI site in pGEM-t Easy:: <i>Cup_0802</i> (reverse)
licCXhoIF	CTC GAG ATT TTT ATT GGC ATT AAT TTA G	<i>licC</i> with flanking XhoI site (forward)
licCXhoIR	GCA AGG CTC GAG TAT ACT CGT CTA AAG	<i>licC</i> with flanking XhoI site (reverse)
Cup_0802XhoIF	CTC GAG TAA ATA CAC CAC TCG TTG C	<i>Cup_0802</i> with flanking XhoI site (forward)
Cup_0802XhoIR	CCG GCT CGA GAG TCT TTG TGA AAT TCC	<i>Cup_0802</i> with flanking XhoI site (reverse)
Cup_0014F	AAT TAA AGA TAG CGT TAA AAG C	<i>Cup_0014</i> (forward)
Cup_0016F	AGA ATC AAG CAA GAT TCT CAC	<i>Cup_0016</i> (forward)
Cup_0018R	CGC ACA TAA GGA TAC TTT G	<i>Cup_0018</i> (reverse)
Cup_0019R	TGC CGC CCT CTT ATG	<i>Cup_0019</i> (reverse)
Cup_0016XbaIF	GGC CTC TAG ACT TGA CTA ATC CAA GAA GC	Insertion of XbaI site in pSC101/pSC101L (forward)
Cup_0017XbaIF	GGC CTC TAG AAA TTC CTT GAC TAG CTC TAA	Insertion of XbaI site in pSC101/pSC101L (reverse)
Cup_0666F	GGA GTG CTG TGC TAA C	<i>Cup_0666</i> (forward)
Cup_0672R	GCA ATA ATT TGC TTA AAT AAT CAA TC	<i>Cup_0672</i> (reverse)
Cup_0667XbaIF	GCG CTC TAG AAA TTT GAT GAG GTT GTG GAG	Insertion of XbaI site in pSC201 (forward)
Cup_0669XbaIF	GCG CTC TAG ATG CGT TTT TTG GAT TGA G	Insertion of XbaI site in pSC201 (reverse)
Cup1_002F	CGG CGG ATC CAT GGC TAA AAA TAC CGA AAT	CUPa_0002 + BamHI UP
repBR	CGG CCT CGA GAA ATA ACT CGC TAT GTG AG	repB + XhoI DOWN

2.2.3 *Molecular cloning*

The molecular cloning techniques used in this thesis, such as ligation, restriction digestion, and *E. coli* calcium chloride transformation were performed as described in Sambrook and Russell (44). Restriction enzymes and the GENEjet plasmid isolation kit were purchased from Fermentas. Genomic DNA was isolated utilizing a High Pure PCR Template Kit (Roche Applied Sciences, Laval, QC).

2.2.4 *Construction of insertional mutants*

The insertional mutants were constructed through amplification of flanking regions of *Cup_0802* and *licC* with primers pairs *Cup_0802F/R* and *licCF/R*, respectively. The resulting 2.5 kb fragments were A-tailed via a 30 min, 70 °C incubation with Taq polymerase (Fermentas), 2 mM MgCl₂ (Fermentas) and 0.2 μM deoxyadenosine triphosphate (Fermentas), then ligated into pGEM-t Easy (Promega, Madison, WI) for 16 h at 4°C, as outlined in the technical guidelines (40). Ligation products were transformed into chemically competent DH5 alpha *E. coli* and screened via blue/white selection (0.5 mM IPTG and 80 μg ml⁻¹ X-Gal) and restriction digestion. Resulting plasmids pGEM-T Easy::*Cup_0802* and pGEM-T Easy::*licC* were linearized with the addition of a *Bam*HI site into the middle of the gene of interest via PCR, with the primers pairs of *Cup_0802outF/R* and *licCoutF/R*, respectively. The resulting 5 kb PCR fragments and pRY109 underwent *Bam*HI digestion in which the ~800 bp fragment from pRY109, containing a chloramphenicol acetyltransferase (*cat*)

from *Campylobacter coli*, were ligated to the digested PCR products to create the insertional mutant plasmids p*Cup_0802::cat* and p*licC::cat* (52, 57). Vectors were chosen with *cat* in the same orientation of either *Cup_0802* or *licC*. The insertional constructs were transformed into chemically competent non-DNA-methylating *E. coli* strain JM110 and screened via restriction digestion and confirmed by sequencing.

Constructs for the double mutant were created by a *Bam*HI digestion of p*Cup_0802::cat*, p*licC::cat* and pMW1007, followed by a ligation of the kanamycin resistance cassette aminoglycoside phosphotransferase-III (*aphA-3*) from pWM1007 with either digested p*Cup_0802::cat* or p*licC::cat*. The vector *aphA-3* in the same orientation of *Cup_0802* or *licC* was selected and designated either p*Cup_0802::aphA-3* or p*licC::aphA-3*.

2.2.5 Natural transformation of *C. upsaliensis*

Natural transformation was performed as described in Wang *et. al.* with modifications (53). Five plates of 16 h - old bacteria were resuspended in BHIY and 250 µl of the cell suspension was layered on top of 500 µl of Brain Heart Infusion agar (BD/Bacto) and incubated under microaerobic conditions for 3 h. Approximately 500 µg to 1 mg of DNA was added to this suspension and further incubated for 16 h. The plate was harvested into 1 ml of BHIY and then plated on fresh blood plates with appropriate antibiotic selection marker. Plates were incubated for up to 14 days under microaerobic conditions.

2.2.6 Electroporation of *C. upsaliensis*

Electroporation was performed as described in Miller *et. al.* with modifications (33). Five plates of bacteria were resuspended in 1 ml of BHIY after 16 h of growth. This bacterial resuspension was pelleted ($8,000 \times g$, 5 min at 4°C) and washed five times with an ice-cold 15 % glycerol, 9 % sucrose solution (EPS). After the final wash, the pellet was resuspended in 2 X the approximate wet pellet volume of EPS and 5 - 20 μg of DNA was added to this suspension. All electroporations were carried out with a BioRad MiniPulser Electroporation System at a capacitance of 25 μFD , a resistance of 600 Ω and a voltage of 2.48 kV, applied to a 0.2 cm cuvette. Following the voltage pulse, the cell suspension was recovered by the addition of 500 μl of microaerobically-degassed BHIY and spotted on fresh Blood agar. The bacteria were recovered for 16 h then resuspended into 1 ml of BHIY and plated on fresh Blood plates with the appropriate antibiotic selection marker. Plates were incubated for up to 14 days under microaerobic conditions.

2.2.7 Conjugation of *C. upsaliensis*

Conjugation was performed as described in Guerry *et. al.* with modifications (17). The plasmid to be transferred was first moved into the *E. coli* conjugative strain RK212.2. Fifty microlitres of 16 h - old RM3195 ($\text{OD}_{600} = 0.5$) was resuspended in BHIY and combined with 50 μl of exponential phase RK212.2 ($\text{OD}_{600} = 1$) containing the vector of interest on top of a sterile 0.45 μm Millipore filter resting on a Blood agar plate. After a 20 h incubation, the plate

was harvested into 1 ml of BHIY and then plated on fresh Blood plates with the appropriate antibiotic selection marker. Plates were incubated for up to 14 days under microaerobic conditions.

2.2.8 Sequencing

Sequencing was carried out with a BigDye Terminator Cycle Sequencing Kit (Life Technologies, Carlsbad, CA, USA). Concentrations used were as follows: 1 X BigDye terminator sequencing buffer, 1 X Ready Reaction premix, 100 - 300 ng of template and 3 - 5 pM primers. The PCR cycling used was an initial denaturation of 96 °C for 1 min, followed by 25 looped cycles of 96 °C for 10 s, 50 °C for 5 s and 60 °C for 4 min. The resulting products were analyzed by the Department of Biological Sciences Molecular Biology Facility on a 3730 DNA Analyzer (Life Sciences), chromatograms visualized with FinchTV (PerkinElmer, Waltham, MA, USA) and sequencing files aligned with BioEdit (Ibis Biosciences, Carlsbad, CA, USA).

2.2.9 Phospholipid extraction and thin-layer chromatography

Phospholipids were extracted as described by Folch *et. al.* with modifications (12). Two confluent plates were harvested, centrifuged (5,000 x g, 5 min), pellets washed with phosphate-buffered saline (PBS), standardized to an $OD_{600} = 10$ in 2 ml of deionized water and lyophilized. Two millilitres of a 2:1 (vol:vol) chloroform:methanol solution was added to the pellet, samples were vortexed then incubated at room temperature for 10 min. The organic and aqueous phase was separated via centrifugation (12,000 × g, 5 min at 4°C) and the lower

phase was extracted and dried down under nitrogen gas. The sample was resuspended in 50 μ l of chloroform in which 10 μ l was spotted on a thin Silica Gel 60A plate (Merck, Germany) and separated using a chloroform-methanol-water (65:25:4 vol:vol:vol) solvent system. Two micrograms of *E. coli* phosphatidylethanolamine and egg phosphatidylcholine (Sigma-Aldrich) were used as standards. After the solvent front reached near the top, the plates were dried and sprayed with a sulfuric acid:naphthol (1:19 vol:vol) solution. The plates were dried again and baked in a high temperature oven till the individual spots could be visualized.

2.2.10 Western transfer and immunoblotting

Whole cell lysates were prepared by resuspending an overnight culture in PBS and standardizing each 1 ml sample to an $OD_{600} = 1$. Samples were then pelleted and resuspended in 150 μ l of PBS. To prepare the proteinase K-, RNase A-, and DNase I- treated samples, the resuspension was first subjected to 100 μ g ml^{-1} DNase I and 50 μ g ml^{-1} RNase A digestion at 37 $^{\circ}C$ for 1 h, followed by 100 μ g ml^{-1} proteinase K digest at 55 $^{\circ}C$ for 1 h. Laemmli protein loading buffer was added and samples boiled at 100 $^{\circ}C$ for 5 min. Whole cell lysates were separated by a 15 % SDS-PAGE gel and then transferred onto polyvinylidene difluoride (PVDF) membranes (Millipore, Billerica, MA, USA). The PVDF membrane was blocked overnight with 5 % bovine serum albumin (BSA) (Bioshop, Burlington, ON) in PBS and 0.1 % Tween (PBST). Immunoblotting of the membrane was carried using 1:5,000 dilution of the monoclonal antibody TEPC-15 (Sigma) in

PBST with 1 % BSA for 1 h followed by another 1 h incubation after several PBST washes in 1:5,000 dilution of rabbit anti-mouse immunoglobulin A antibody conjugated to alkaline phosphatase (Santa Cruz Biotechnology, Santa Cruz, CA, USA). The blot was developed with nitroblue tetrazolium-5-bromo-4-chloro-3-indolylphosphate solution (NBT-BCIP) (Roche).

2.2.11 LOS analysis with capillary electrophoresis-electrospray ionization mass spectrometry (CE-ESI MS)

Samples were prepared and analyzed as described by Szymanski *et. al.* (48). A half plate of confluent bacteria was resuspended in 500 μ l of PBS after 24 h of growth. One milliliter of 100 % ethanol was then added, mixed, and incubated for 1 h at room temperature. This pellet was then washed twice in 100% ethanol, twice in 100% acetone, and allowed to air dry overnight. The sample was resuspended in 200 μ l of deionized water supplemented with 10 μ g ml⁻¹ of proteinase K. This was incubated at 37 °C for 4 h and then the enzyme was heat-killed at 75 °C for 10 min and the sample lyophilized. The cells were then resuspended in 200 μ l of 20 mM ammonium acetate (pH 7.5) containing 100 μ g ml⁻¹ RNase and 50 μ g ml⁻¹ DNase and incubated at 37 °C for 6 h before being lyophilized. The hydrazinolysis of the *C. upsaliensis* LOS preparations was done by Denis Brochu at the Institute for Biological Sciences, National Research Council of Canada, where the samples were stirred with 200 μ l of hydrazine at 37 °C for 2 h then placed in an ice bath, in which the excess hydrazine was destroyed with cold acetone in dry ice. The deacylated LOS was isolated by centrifugation

(16,000 × g for 15 min), and the product was washed again with acetone, centrifuged, resuspended in water, and centrifuged, and then lyophilized.

The capillary electrophoresis - electrospray ionization mass spectrometry of the LOS preparations was done by Dr. Jianjun Li at the Institute for Biological Sciences, National Research Council of Canada, utilizing a Prince CE system (Prince Technologies, Emmen, The Netherlands) coupled to a 4000 QTRAP mass spectrometer (AB Sciex, Concord, ON, Canada) (10). A sheath solution (isopropanol-methanol, 2:1) was delivered at a flow rate of 1.5 $\mu\text{l min}^{-1}$ and separation obtained on an approximately 90-cm-length bare fused-silica capillary using 15 mM ammonium acetate in deionized water, pH 9.0. An electrospray ionization voltage of 5 keV was applied and mass spectrometric data acquired in negative ion mode.

2.2.12 CPS analysis by high resolution magic angle spinning NMR (HR-MAS NMR)

Bacteria were grown overnight on a Blood agar plate, harvested with a sterile loop and then resuspended in 1 ml of 10 % sodium azide in PBS prepared with 99.9 % D₂O for 1 h at room temperature. Cells were pelleted by centrifugation (5000 x g for 5 min), supernatant discarded and cell pellet washed with PBS in 99.9 % D₂O. This wash procedure was repeated three times and the resulting pellet was resuspended in 10 μl of D₂O containing 0.1% 3-(trimethylsilyl)propionic-2,2,3,3-*d*₄ acid sodium salt (TSP). Forty μl of cell

suspension was loaded into a 4 mm nano NMR tube (Varian Inc., Palo Alto, USA).

HR-MAS NMR experiments were performed with a Varian/Agilent VNMRS 600 MHz spectrometer equipped with a Varian 4 mm indirect detection gradient nano-NMR probe with a broadband decoupling coil. Samples were spun at 2.5 – 3 kHz, and spectra recorded at ambient temperature (23 °C). HR-MAS experiments were performed with suppression of the HOD signal using presaturation. ^1H NMR spectra were acquired using the Carr-Purcell-Meiboom-Gill pulse sequence (900-(τ -180- τ) n acquisition) to remove broad signals originating from lipids and solid-like materials and were typically obtained using 256 transients. One-dimensional ^1H - ^{31}P HSQC spectra were acquired using the standard Varian HSQC pulse sequence with one-dimensional spectra representing the first increment of the standard HSQC experiment. All ^1H NMR spectra were referenced to an internal TSP standard (δ_{H} 0.00 ppm).

2.2.13 Cloning of Cup_0802 and licC into existing complementation vectors

The gene of interest (either *Cup_0802* or *licC*) was PCR amplified with flanking *XhoI* sites utilizing the primer pairs Cup_0802XhoIF/ Cup_0802XhoIR or licCXhoIF/ licCXhoIR. These were digested with *XhoI* and ligated into the multicloning site of *XhoI* digested pWM1007, pCE107/70, or pRRK. The vector with the gene of interest in the same orientation of the promoter (in the case of pCE107/70) or in the same orientation of the *aphA-3* was selected and named accordingly.

2.2.14 Cloning and construction of insertional complementation vectors

Construction of both vectors is outlined in Figure 2.2. For construction of pSC1, the intergenic regions between *Cup_0016* to *Cup_0017* were amplified by PCR using primers Cup_0016F and Cup_0018R, A-tailed, and then TA-cloned into pGEM-t Easy to produce pSC101. An *Xba*I site was inserted via PCR using primers Cup_0016XbaIR and Cup_0017XbaIF to create pSC102, then an *Xba*I-digested 159bp oligo (5' CCG GTC TAG ATT CCT TGA TAG ATT TAT GAT ATA GTG GAT AGA TTT ATG ATA TAA TGA GTT ATC AAC AAA TCG GAA TTT ACG GAG GAT AAC ATA TGC GGA GAT TAG GCC CTC GAG TTA ACA GAC TAC GGG ATC CAT TTT AGA GCT AGT CCT CTA GAG GCC 3', italicized promoter; bolded MCS; underlined *Bam*HI site for *aphA-3*) (Integrated DNA technologies) was ligated into the *Xba*I-digested pSC102 to construct pSC103. The kanamycin resistance gene *aphA-3*, from pWM1007, and pSC103 were digested with *Bam*HI and ligated together to create pSC1. The gene of interest (either *Cup_0802* or *licC*) was PCR amplified with flanking *Xho*I sites utilizing the primer pairs Cup_0802XhoIF/ Cup_0802XhoIR or licCXhoIF/ licCXhoIR. These were digested with *Xho*I and ligated into *Xho*I digested pSC1. The vector with the gene of interest in the same orientation of the *cat* promoter and *aphA-3* was selected and designated either pSC1::*Cup_0802* (containing *Cup_0802*) or pSC1::*licC* (containing *licC*).

A larger version of pSC1, designated pSC1L, utilized the PCR product formed from primers Cup_0014F and Cup_0019R, which was TA-cloned into pGEM-t Easy to produce pSC101L. All downstream cloning proceeded as described for pSC1 with vectors pSC101L, pSC102L, pSC103L, pSC1L::*Cup_0802* and pSC1L::*licC*.

For construction of pSC2, *Cup_0666* to *Cup_0672* was amplified by PCR with primers Cup_0666F and Cup_0672R, A-tailed, and TA-cloned into pGEM-t Easy (Promega) to make pSC201. An *Xba*I site was inserted between *Cup_0667* and *Cup_0669* of pSC201 via PCR with the primers Cup_667XbaIR and Cup_669XbaIF to make pSC202. Construction of pSC203, pSC2, pSC2::*licC* and pSC2::*Cup_0802* proceeded as in the creation of pSC103, pSC1, pSC::*licC* and pSC1::*Cup_0802*, respectively.

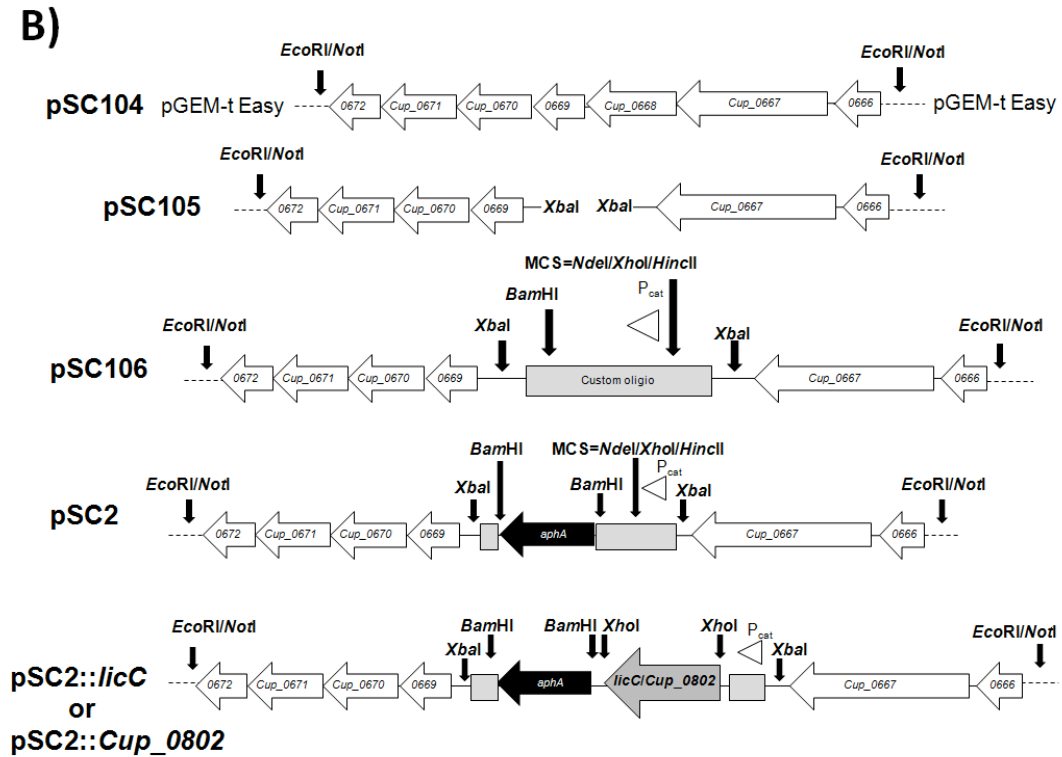
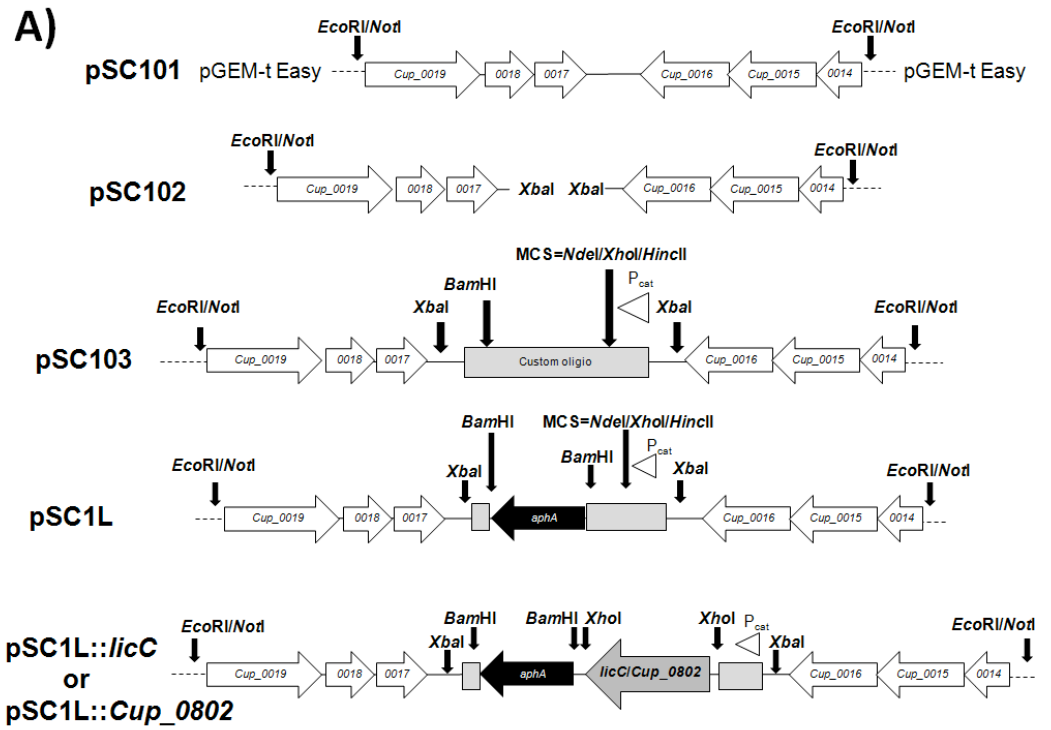

Figure 2.2 Construction of RM3195 genomic integration vectors pSC1 and pSC2.

For details concerning construction, please refer to *Materials and methods*. **A)** Construction of pSC1. pSC101, insertion of *Cup_0016* to *Cup_0019* into multicloning site of pGEM-t Easy; pSC102, insertion of an *XbaI* site between *Cup_0016* and *Cup_0017* via PCR; pSC103, insertion of oligonucleotide containing promoter and new multicloning site into *XbaI* site; pSC1, insertion of *aphA-3* into *BamHI* site; insertion of *licC* or *CUP_0802* into *XhoI* site to create pSC1::*licC* or pSC1::*CUP_0802*, respectfully. **B)** Construction of pSC2. pSC201, insertion of *Cup_0666* to *Cup_0672* into pGEM-t Easy multicloning site; pSC202 insertion of an *XbaI* site between *Cup_0667* and *Cup_0669* via PCR; Construction of pSC203, pSC2, pSC2::*licC* and pSC2::*Cup_0802* proceeded as in the generation of pSC103, pSC1, pSC::*licC* and pSC1::*Cup_0802*, respectfully.

2.2.15 Cloning and construction of in trans complementation vectors

For construction of pSC3, p3195-1 from *C. upsaliensis* RM3195 was isolated via plasmid preparation (Fermentas), amplified by PCR with primers Cup1_002F and repBR. This linearized product was A-tailed and ligated into pGEM-t Easy to generate pSC3.

For construction of pSC4, isolated p3195-1 was PCR amplified with flanking *BamHI* sites with primers p3195BamHIF and p3195BamHIR. Both PCR product and pWM1007 were digested with *BamHI* and the kanamycin resistance gene, *aphA-3*, from pWM1007 was ligated to the digested PCR product to create pSC4.

2.3 Results

2.3.1 The CPS of RM3195 is decorated with MeOPN

C. upsaliensis isolate RM3195 was predicted from homology searches to contain the biosynthetic locus for production of MeOPN. *Cup_0802*, *Cup_0803* and *Cup_0804* encode for a putative kinase, amidotransferase, and nucleotidyltransferase, respectfully (Figure 2.3A). Each enzyme is homologous to known MeOPN biosynthetic proteins in *C. jejuni* 11168, and their protein identity scores for their respective homologue are over 70%.

MeOPN display was detected by high resolution magic angle spinning ^1H NMR (HR-MAS ^1H NMR), as well as ^{31}P decoupled, ^1H - ^{31}P Heteronuclear Single Quantum Coherence (HSQC) HR-MAS NMR experiments. Previous studies have demonstrated that MeOPN can be detected on the surface of intact *Campylobacter* cells due to its $-\text{CH}_3$ protons. These produce an intense signal compared to the other CPS resonances as well as demonstrate a unique chemical shift and phosphorus coupling that aids in their detection (32). RM3195 wt expressed a signal at approximately δ_{H} 3.7ppm (Figure 2.3B) which confirmed the presence of MeOPN. In a decoupled H- ^{31}P HSQC HR-MAS NMR experiment, this signal appeared as a single resonance, indicating the addition of MeOPN to a single CPS residue.

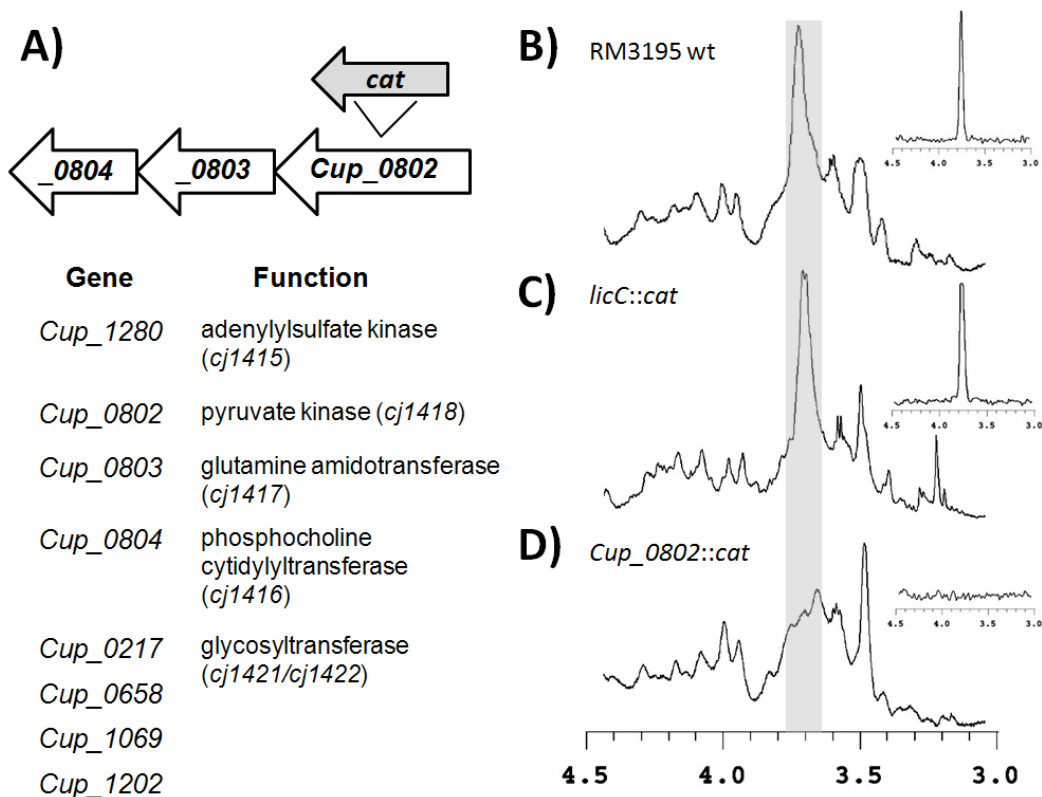

Figure 2.3 The CPS of *C. upsaliensis* RM3195 is modified by MeOPN and mutation to *Cup_0802* removes this modification. **A)** Predicted MeOPN biosynthetic locus. HR-MAS ^1H NMR spectra with a CPMG pulse sequence of **B)** RM3195 wt, **C)** *Cup_0802::cat*, and **D)** *licC::cat*. Insets are $\text{H-}^{31}\text{P}$ HSQC HR-MAS NMR experiments. For all NMR experiments, 40 μl of cells were examined at 600 MHz using 256 scans.

2.3.2 Construction of a MeOPN mutant

To elucidate if RM3195 wt encoded the necessary enzymes to modify its CPS with MeOPN, a mutant in this putative biosynthetic pathway was constructed. *Cup_0802* was interrupted by the insertion of *cat*, a chloramphenicol

acetyltransferase originally isolated from *Campylobacter coli* (52). Mutant candidates were initially identified by growth on Blood agar plates supplemented with chloramphenicol and confirmed by PCR and sequencing. *Cup_0802::cat* does not produce MeOPN, as demonstrated by the loss of the 3.7 ppm MeOPN signal in both the ^1H CPMG and ^1H - ^{31}P HSQC HR-MAS NMR scans (Figure 2.3D).

2.3.3 RM3195 modifies its LOS with PCho

C. upsaliensis isolate RM3195 also contains the *licABCD* locus, which is responsible for PCho modification in multiple bacterial genera (Figure 2.4A) (13, 45, 55). The RM3195 *licABCD* locus has the highest homology to the *licABCD* locus from *Neisseria wadsworthii*, with protein identity scores of approximately 50% or higher. Bacterial phosphocholine cytidyldyltransferases can modify diverse substrates, such as protein, LOS, lipopolysaccharide and phospholipids, depending on its amino acid composition (46). The RM3195 transferase does not appear to be homologous to *P. aeruginosa* PA01's or PA14's cytidyldyltransferases, which are used for the creation of phosphatidylcholine or the modification of protein elongation factor Tu.

The presence of PCho was examined by screening whole cell lysates and proteinase K-treated lysates with the commercially available monoclonal antibody, TEPC-15. TEPC-15 has a high specificity for PCho and does not cross react with related compounds such as choline or phosphoethanolamine. The low molecular weight bands in both the RM3195 wt whole cell lysate and proteinase

K-treated lysate reacted strongly with TEPC-15 (Figure 2.5B). This indicated there was no PCho protein modified substrates in RM3195 and that the 15kDa bands correspond to PCho modified LOS.

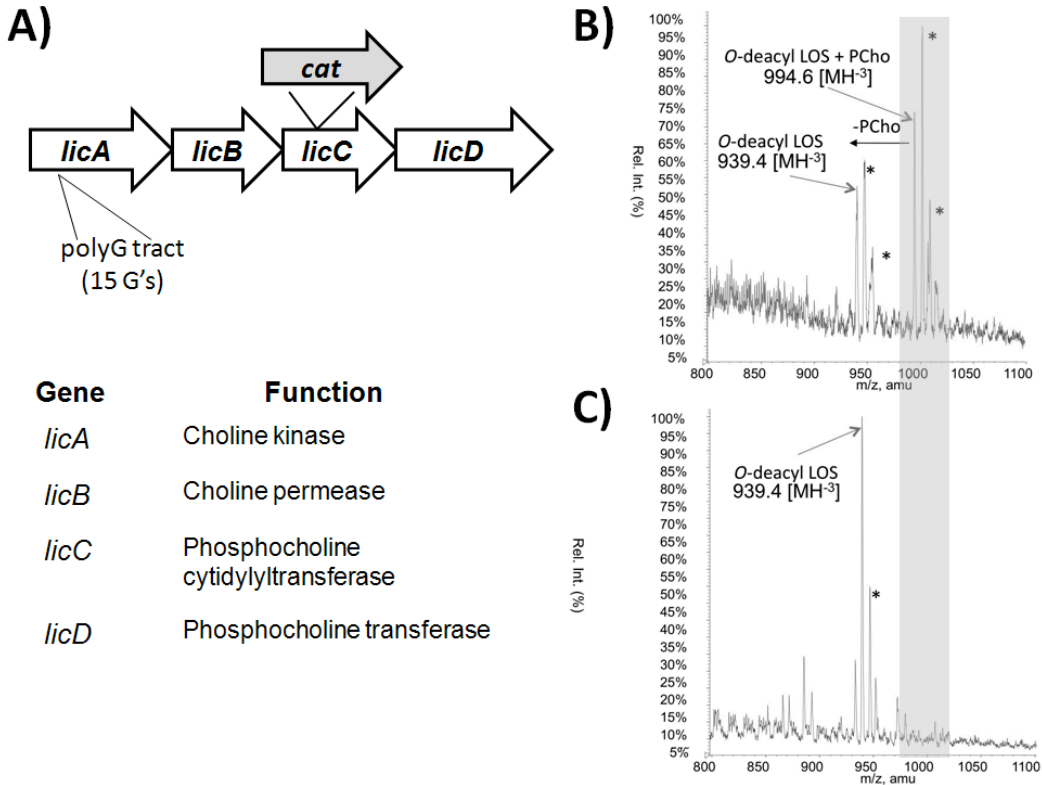

Figure 2.4 The LOS of *C. upsaliensis* RM3195 is decorated by PCho and mutation to *licC* removes this modification. **A)** Predicted PCho biosynthetic locus. Mass spectra of deacylated LOS from **B)** RM3195 wt and **C)** *licC::cat*. RM3195 wt analyses identified two abundant molecular ions at m/z 994.6 and 939.4 which corresponded to PCho modified LOS and the unmodified species, respectively. Peak identities were confirmed by MS/MS. For the *licC::cat* spectrum only the unmodified species ($m/z=939.4, MH^{-3}$) was identified. * denote sodium adducts.

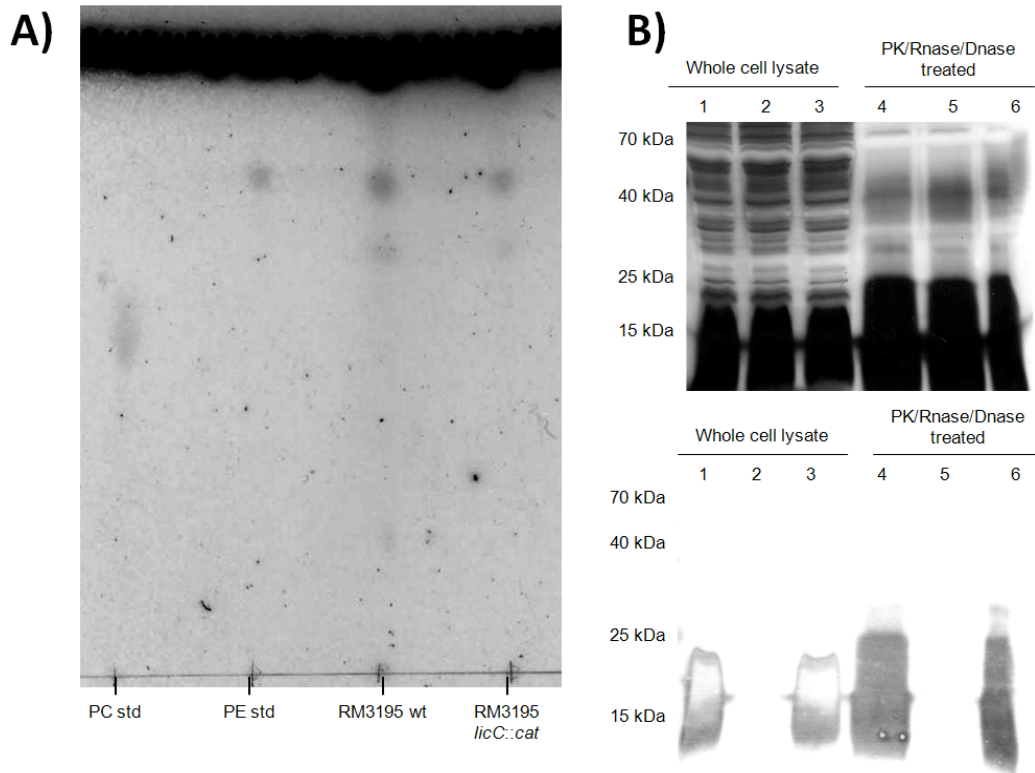

Figure 2.5 The PCho modification is located on the LOS, and does not decorate a proteinaceous substrate, or is present as phosphatidylcholine. **A)** Separation of RM3195 wt and RM3195 *licC::cat* by thin layer chromatography; PC std, 2 μ g phosphatidylcholine standard; PE std, 2 μ g phosphoethanolamine standard. **B)** Silver stain and western blot of RM3195 wt, RM3195 *Cup_0802::cat* and RM3195 *licC::cat* untreated or proteinase K-, RNase A-, DNase I-treated whole cell lysates. PCho containing molecules were separated by a 15 % SDS-PAGE gel and detected with the MAb TEPC-15. Lanes: Whole cell lysates: 1, RM3195 wt; 2, RM3195 *licC::cat*; 3, RM3195 *Cup_0802::cat*; proteinase K-/RNase A-/DNase I-treated whole cell lysates: 4, RM3195 wt; 5, RM3195 *licC::cat*; 6, RM3195 *Cup_0802::cat*. Size markers are protein standards are in kilodaltons.

PCho decoration of the LOS was confirmed by capillary electrophoresis-electrospray ionization mass spectrometry (CE-ESI MS). RM3195 wt LOS contained two species; a PCho modified form ($m/z=994.6$, MH-3) and an undecorated form ($m/z=939.4$, MH-3) (Figure 2.4B). Interestingly, the LOS composition was similar to *Haemophilus* sp. in its acylation pattern as well as its tri-heptose core; this is currently under investigation. MS/MS suggests that the PCho is attached to a hexose which is attached to the second heptose on the inner core.

To study if RM3195 also produced phosphatidylcholine, thin layer chromatography of extracted lipids was performed. RM3195 wt appeared to contain multiple phospholipids, including phosphatidylethanolamine (Figure 2.5B). However, none of RM3195 wt Rf values corresponded to the Rf value of the phosphatidylcholine standard (Figure 2.5A).

2.3.4 Construction of a PCho mutant

Disruption of the putative phosphocholine biosynthetic loci was achieved by inserting *cat* into *licC*. As with *Cup_0802::cat*, mutant candidates were initially identified by growth on Blood agar plates supplemented with chloramphenicol and confirmed by PCR and sequencing. *licC::cat* LOS is not recognized by TEPC-15 (Figure 2.5B) and in a CE-ESI MS experiment, only the undecorated LOS form ($m/z=939.4$, MH³) was present (Figure 2.4C). This suggests *licC::cat* has lost its ability to modify the LOS with PCho.

2.3.5 *CUP_0804 does not compensate for the loss of LicC*

The biosynthetic pathways of both PCho and MeOPN involve putative phosphocholine cytidyldyltransferases. In RM3195, LicC and CUP_0804 are homologous and have 32% protein identity. Interestingly, CUP_0804 cannot compensate for the loss of LicC, as evident by the inability to produce PCho-decorated LOS in *licC::cat* (Figure 2.5B)

2.3.6 *Construction of a double MeOPN and PCho mutant*

To enable further downstream characterization of the phenotypical roles of MeOPN and PCho, construction of a double *C. upsaliensis* *Cup_0802* and *licC* mutant was attempted. *cat* was replaced with *aphA-3* in pGEM-T Easy::*Cup_0802* or pGEM-T Easy::*licC* after a *Bam*HI digestion, (the vectors used to create the original chloramphenicol resistant mutants). Despite multiple attempts at electroporation and natural transformation with *Cup_0802::cat* and *licC::cat*, kanamycin and chloramphenicol resistant mutants were isolated, but none contained mutations to both *Cup_0802* and *licC*.

2.3.7 *Transformation of C. upsaliensis with existing C. jejuni complementation vectors*

The vectors pWM1007::*Cup_0802*, pWM1007::*licC*, pCE107/70::*Cup_0802*, pCE107/70::*licC*, pRRK::*Cup_0802* and pRRK::*licC* were used for transformation into *C. upsaliensis* via natural transformation and electroporation. However, repeated attempts with any of the available vectors and

RM3195 wt, *Cup_0802::cat* and *licC::cat*, resulted in no transformants on media supplemented with kanamycin (Table 2.3).

Table 2.3 Summary of complementation vectors constructed and transformation attempts.

Vector	Cloned into DH5 α ?	Natural transformation	Electroporation	Conjugation	Cloned into <i>C.upsaliensis</i>
pCE107/70	Y	X3	X3	X3	N
pWM1007	Y	X3	X3	X3	N
pRRK	Y	X3	X3	-	N
pCE107/70:: <i>Cup_0802</i>	Y	X3	X3	X3	N
pCE107/70:: <i>licC</i>	Y	X3	X3	X3	N
pWM1007:: <i>Cup_0802</i>	Y	X3	X3	X3	N
pWM1007:: <i>licC</i>	Y	X3	X3	X3	N
pRRK:: <i>Cup_0802</i>	Y	X3	X3	-	N
pRRK:: <i>licC</i>	Y	X3	X3	-	N
pSC3	N	-	-	-	N
pSC4	N	X2	X2	X2	N
pSC1	N	X5	X5	-	N
pSC1:: <i>licC</i>	Y	X5	X5	-	N
pSC1:: <i>Cup_0802</i>	Y	X5	X5	-	N
pSC1L	Y	X3	X3	X3	N
pSC1L:: <i>licC</i>	Y	X3	X3	X3	N
pSC1L:: <i>Cup_0802</i>	Y	X3	X3	X3	N
pSC2	Y	X3	X3	X3	N
pSC2:: <i>licC</i>	Y	X3	X3	X3	N
pSC2:: <i>Cup_0802</i>	Y	X3	X3	X3	N

2.3.8 Construction of a *C. upsaliensis* complementation vector

Construction of a *C. upsaliensis* specific complementation vector was undertaken to address the inability of RM3195 to retain the *C. jejuni* constructs.

Two strategies were devised: 1) genomic integration vector; targeting an

intergenic region or a pseudogene, and 2) an *in trans* vector; utilizing the backbone of RM3195's smaller 3 kb plasmid.

Creation of an *in trans* vector was unsuccessful. The vector pSC3 could not replicate in DH5 α and pSC4 was not retained in RM3195 wt (Table 2.3). However, the integration vector strategy proved more fruitful and two vectors were constructed; pSC1, (which was later modified to pSC1L) and pSC2. The vectors pSC1/pSC1L contained *aphA-3*, a kanamycin resistance cassette from *C. coli*, a multicloning site under the control of the promoter from *cat*, and on either side of these features, flanking sequence in order to insert into the intergenic space between *Cup_0016* and *Cup_0017* (Figure 2.2A). The vector pSC2 contains the same features except for its flanking regions which were designed to insert into the pseudogene *Cup_0668* (Figure 2.2B). Both vectors were contained within pGEM-T Easy, a commercially available high copy vector in *E. coli*, which would act as a suicide vector within RM3195. All empty- and gene-of-interest vectors were confirmed by restriction digestion and sequencing.

2.3.9 Transformation of *C. upsaliensis* with *pSC1*, *pSC1L* and *pSC2*

Unfortunately, repeated attempts of natural transformation, electroporation and conjugation yielded no transformants for pSC1, pSC2 or any of their *Cup_0802*- or *licC*-containing variants (Table 2.3). Over 60 kanamycin resistant colonies were screened for each construct, but a complemented strain was not isolated. The vector pSC1 flanking regions were increased by 1 kb on each end to create pSC1L. This increased the area of homology between the vector and the

chromosome as well as increased the probability of including the *C. upsaliensis* putative competence uptake sequence. Yet, pSC1L also did not produce any transformants.

2.4 Discussion

Within this work, we show *C. upsaliensis* RM3195 is amenable to genetic manipulation, as evident by the construction of a MeOPN and a PCho mutant described in this study. To our knowledge, this is the first report of PCho–modified LOS in an intestinal bacterial pathogen. PCho display was previously thought to be restricted to bacteria involved in diseases such as pneumonia and meningitis. Both MeOPN and PCho have been implicated as virulence factors in other bacteria. The two mutants constructed in this report will allow for further study into the role of these phosphorylated moieties in virulence. The generation of these two mutants highlights a successful protocol which can be applied for the mutation of other putative *C. upsaliensis* virulence genes, to increase our understanding of the virulence mechanisms of this emerging pathogen.

Complementation of a mutant is integral in molecular biology to demonstrate a specific gene is responsible for a bacterial virulence factor (11). Allelic replacement of the native gene into the mutant must restore wild-type pathogenesis. Unfortunately, despite several strategies employed to generate a successful *C. upsaliensis* complementation system, a final transformant was not achieved from the methodologies described in this report.

RM3195 did not retain any of the kanamycin resistance *C. jejuni* complementation vectors. This inability to maintain pRRK, pCE107/70, or pWM1007 could be due to several factors: RM3195 may not recognize the vector's origin of replication, the vectors may have been incompatible with the two plasmids already present in RM3195, or the DNA composition or the *E. coli* methylation patterns of the vectors marked them for degradation by restriction endonucleases.

All of the commonly used shuttle vectors for *C. jejuni* utilize the same mechanism of replication, which can impact successful complementation. All pMW, pWM, pRY derivatives, contain the same *Campylobacter* replication functions as well as the same origin of transfer (1, 34, 35, 41, 56, 57). This renders these listed shuttle vectors unusable if their replication mechanisms are incompatible with existing native *Campylobacter* plasmids, or if the replication mechanisms encoded are not recognized by the recipient strain.

Campylobacter strain-to-strain variability is also a factor in expression of the complementing gene. *C. jejuni* is highly susceptible to phase variation and can quickly alter its phenotype as the results of selective pressures in its storage, culturing and passaging conditions (6, 15). Promoter sequence composition is subject to high strain-to-strain variability. The standard GFP *C. jejuni* vector, pMW1007, was originally constructed with an idealized promoter based on *C. jejuni* promoter alignments (34). It has a high fluorescence intensity in *C. jejuni* RM1221, but when moved to other strains, such as 81-176 and F38011, the

fluorescence is decreased with no change to plasmid copy number (3, 35). This has been rectified by exchanging the original promoter for a strain specific strong constitutive promoter for use in fluorescent microscopy and flow cytometry.

Modification of DNA through processes such as methylation has been reported to increase the transformation efficiency in *Campylobacter*. In *C. jejuni*, transformation efficiency is increased exponentially by passaging a vector in a highly competent *C. jejuni* strain before moving it into the strain of interest, compared to a vector directly isolated from *E. coli* (34, 53). However, if the recipient *C. jejuni* strain carries other host specific restriction modification systems or does not recognize the methylation pattern, this could prevent the introduction of the passaged vector. *C. upsaliensis* encodes extensive restriction modification systems which could negatively impact the introduction of exogenous genes. RM3195 is predicted to contain at least three Type I, one Type II and two Type III putative restriction modification loci, as well as 15 putative adenine- or cytosine- specific DNA methyltransferases (13). Zhang and Blaser have addressed a similar issue in *Helicobacter pylori*, by deleting four active Type II restriction endonucleases to increase transformation efficiency (58). This resulted in a 20-fold increase in DNA fragment integration of a *sacB*-based vector with no difference in cell growth between wild type and the restriction endonuclease mutant (58). Deletion of *C. upsaliensis* restriction modification machinery may be a viable future strategy to increase transformation efficiency;

however the use of a *sacB*-based vector may not be a viable option since RM3195 does not encode a sucrose permease.

In order to address the inability to generate a complement utilizing existing resources, the construction of a *C. upsaliensis* complementation vector was undertaken. Two vectors were constructed incorporating the entirety of RM3195's smaller 3 kb plasmid. The plasmid p3195-1 was identified as a possible complementation vector candidate since it encoded a defined plasmid replication region (13). Unfortunately, both pSC3 and pSC4 produced no colonies when transformed into *E. coli* and all RM3195 kanamycin resistant colonies resulting from a transformation with pSC4 did not contain the manipulated vector. This inability of pSC3 and pSC4 to be moved into *E. coli* could be due to the presence of a putative toxin encoding gene located on p3195-1 (13). The location of the partner antitoxin in RM3195 is currently unknown.

Two genomic integration vectors were also constructed. One inserted into the intergenic region between *Cup_0016* and *Cup_0017*, while the other targeted the pseudogene *Cup_0668*. All constructs were moved to a non-methylating strain of *E. coli* to address restriction modification issues. These vectors could not be first passaged in a *C. jejuni* strain because the origin of replication of pGEM-t Easy is not recognized. Unfortunately, all variants of both vectors were unable to be moved into RM3195 wt or mutants.

RM3195 wt could not survive at the kanamycin concentrations used for complementation selection in this study. This is consistent with the antibiotic

resistance profile generated by Fouts and colleagues (13). Interestingly, RM3195 is able to form spontaneous kanamycin resistant mutants at a high frequency after subjection to natural transformation, electroporation or conjugation. This renders complementation of RM3195 by a kanamycin resistance-based vector near impossible. Spontaneous aminoglycoside resistance in *Campylobacter* has never been reported. *C. jejuni* kanamycin resistance is usually achieved through a non-chromosomal-based enzymatic modification, and with the exception of *C. coli*, is not common (16). Usually a kanamycin resistance cassette is encoded on a plasmid or transposable element which enables *C. jejuni* to survive in the presence of kanamycin (43). Other bacteria confer endogenous resistance to kanamycin by mutation to genes encoding ribosomal proteins, ribosomal RNA species, respiratory chain components, H⁺-ATPase subunits, oligopeptide permeases and lipopolysaccharide biosynthetic genes (9, 20, 21, 25-27, 36, 37, 49, 50)(20, 21, 25, 26). Further study of the nature of this spontaneous mutation behavior of RM3195 should be investigated. The *C. upsaliensis* complementation vectors generated in this study may be salvaged by the replacement of *aphA-3* with another *Campylobacter*-origin antibiotic resistant cassette.

The phosphorylated surface molecules MeOPN and PCho decorate the surface of *C. upsaliensis*. Through the development of tools for the genetic manipulation of *C. upsaliensis*, we are now able to create mutants in these biosynthetic pathways to elucidate their biological function. To our knowledge this is the first report of the construction of a genetic mutant in *C. upsaliensis*. The

protocol derived in this report can be applied for the future mutation of other putative virulence factors to study their role in *C. upsaliensis* pathogenesis to increase our understanding of the role this organism plays in human disease.

2.5 Acknowledgements

The authors would like to thank Dr. Jianjun Li for mass spectrometry analysis of de-acylated LOS samples, Dennis Brochu for hydrazinolysis of LOS samples, Dr. William Miller for the constructing the dendrogram and Tom Hantos for TLC supplies.

2.6 Literature cited

1. **Alfredson DA, Korolik V.** 2003. Sequence analysis of a cryptic plasmid pCJ419 from *Campylobacter jejuni* and construction of an *Escherichia coli*-*Campylobacter* shuttle vector. *Plasmid*. **50**:152-160.
2. **Allos BM.** 1997. Association between *Campylobacter* infection and Guillain-Barré syndrome. *J. Infect. Dis.* **176 S2**:S125-8.
3. **Apel D, Ellermeier J, Pryjma M, Dirita VJ, Gaynor EC.** 2012. Characterization of *Campylobacter jejuni* RacRS reveals roles in the heat shock response, motility, and maintenance of cell length homogeneity. *J. Bacteriol.* **194**:2342-2354.
4. **Bacon DJ, Szymanski CM, Burr DH, Silver RP, Alm RA, Guerry P.** 2001. A phase-variable capsule is involved in virulence of *Campylobacter jejuni* 81-176. *Mol. Microbiol.* **40**:769-777.
5. **Bourke B, Chan VL, Sherman P.** 1998. *Campylobacter upsaliensis*: Waiting in the wings. *Clin. Microbiol. Rev.* **11**:440-449.
6. **Carrillo CD, Taboada E, Nash JH, Lanthier P, Kelly J, Lau PC, Verhulp R, Mykytczuk O, Sy J, Findlay WA, Amoako K, Gomis S, Willson P, Austin JW, Potter A, Babiuk L, Allan B, Szymanski CM.** 2004. Genome-wide expression analyses of *Campylobacter jejuni* NCTC11168 reveals coordinate regulation of motility and virulence by *flhA*. *J. Biol. Chem.* **279**:20327-20338.
7. **Carter JE, Cimolai N.** 1996. Hemolytic-uremic syndrome associated with acute *Campylobacter upsaliensis* gastroenteritis. *Nephron.* **74**:489.
8. **Champion OL, Karlyshev AV, Senior NJ, Woodward M, La Ragione R, Howard SL, Wren BW, Titball RW.** 2010. Insect infection model for *Campylobacter jejuni* reveals that *O*-methyl phosphoramidate has insecticidal activity. *J. Infect. Dis.*
9. **Davies J, Wright GD.** 1997. Bacterial resistance to aminoglycoside antibiotics. *Trends Microbiol.* **5**:234-240.
10. **Dzieciatkowska M, Brochu D, van Belkum A, Heikema AP, Yuki N, Houliston RS, Richards JC, Gilbert M, Li J.** 2007. Mass spectrometric analysis of intact lipooligosaccharide: Direct evidence for *O*-acetylated sialic acids and discovery of *O*-linked glycine expressed by *Campylobacter jejuni*. *Biochemistry.* **46**:14704-14714.

11. **Falkow S.** 1988. Molecular Koch's postulates applied to microbial pathogenicity. *Rev. Infect. Dis.* **10 Suppl 2**:S274-6.
12. **Folch J, Lees M, Slone Stanley GH.** 1957. A simple method for the isolation and purification of total lipides from animal tissues. *J. Biol. Chem.* **226**:497-509.
13. **Fouts DE, Mongodin EF, Mandrell RE, Miller WG, Rasko DA, Ravel J, Brinkac LM, DeBoy RT, Parker CT, Daugherty SC, Dodson RJ, Durkin AS, Madupu R, Sullivan SA, Shetty JU, Ayodeji MA, Shvartsbeyn A, Schatz MC, Badger JH, Fraser CM, Nelson KE.** 2005. Major structural differences and novel potential virulence mechanisms from the genomes of multiple *Campylobacter* species. *PLoS Biol.* **3**:e15.
14. **Gaudreau C, Lamothe F.** 1992. *Campylobacter upsaliensis* isolated from a breast abscess. *J. Clin. Microbiol.* **30**:1354-1356.
15. **Gaynor EC, Cawthraw S, Manning G, MacKichan JK, Falkow S, Newell DG.** 2004. The genome-sequenced variant of *Campylobacter jejuni* NCTC 11168 and the original clonal clinical isolate differ markedly in colonization, gene expression, and virulence-associated phenotypes. *J. Bacteriol.* **186**:503-517.
16. **Gibreel A, Skold O, Taylor DE.** 2004. Characterization of plasmid-mediated *aphA-3* kanamycin resistance in *Campylobacter jejuni*. *Microb. Drug Resist.* **10**:98-105.
17. **Guerry P, Ewing CP, Hickey TE, Prendergast MM, Moran AP.** 2000. Sialylation of lipooligosaccharide cores affects immunogenicity and serum resistance of *Campylobacter jejuni*. *Infect. Immun.* **68**:6656-6662.
18. **Guerry, P, Szymanski, CM, Prendergast, MM, Hickey, TE, Ewing, CP, Pattarini, DL, Moran, AP.** 2002. Phase variation of *Campylobacter jejuni* 81-176 lipooligosaccharide affects ganglioside mimicry and invasiveness in vitro. *Infect. Immun.* **70**:787-793.
19. **Gurgan T, Diker KS.** 1994. Abortion associated with *Campylobacter upsaliensis*. *J. Clin. Microbiol.* **32**:3093-3094.
20. **Hancock RE.** 1981. Aminoglycoside uptake and mode of action--with special reference to streptomycin and gentamicin. I. Antagonists and mutants. *J. Antimicrob. Chemother.* **8**:249-276.
21. **Hancock RE, Farmer SW, Li ZS, Poole K.** 1991. Interaction of aminoglycosides with the outer membranes and purified lipopolysaccharide and OmpF porin of *Escherichia coli*. *Antimicrob. Agents Chemother.* **35**:1309-1314.

22. **Kanipes MI, Papp-Szabo E, Guerry P, Monteiro MA.** 2006. Mutation of *waaC*, encoding heptosyltransferase I in *Campylobacter jejuni* 81-176, affects the structure of both lipooligosaccharide and capsular carbohydrate. *J. Bacteriol.* **188**:3273-3279.
23. **Karlyshev AV, Everest P, Linton D, Cawthraw S, Newell DG, Wren BW.** 2004. The *Campylobacter jejuni* general glycosylation system is important for attachment to human epithelial cells and in the colonization of chicks. *Microbiology.* **150**:1957-1964.
24. **Karlyshev AV, Wren BW.** 2005. Development and application of an insertional system for gene delivery and expression in *Campylobacter jejuni*. *Appl. Environ. Microbiol.* **71**:4004-4013.
25. **Kashiwagi K, Miyaji A, Ikeda S, Tobe T, Sasakawa C, Igarashi K.** 1992. Increase of sensitivity to aminoglycoside antibiotics by polyamine-induced protein (oligopeptide-binding protein) in *Escherichia coli*. *J. Bacteriol.* **174**:4331-4337.
26. **Kashiwagi K, Tsubako MH, Sakata K, Saisho T, Igarashi A, da Costa SO, Igarashi K.** 1998. Relationship between spontaneous aminoglycoside resistance in *Escherichia coli* and a decrease in oligopeptide binding protein. *J. Bacteriol.* **180**:5484-5488.
27. **Kotra LP, Haddad J, Mobashery S.** 2000. Aminoglycosides: Perspectives on mechanisms of action and resistance and strategies to counter resistance. *Antimicrob. Agents Chemother.* **44**:3249-3256.
28. **Labigne-Roussel A, Courcoux P, Tompkins L.** 1988. Gene disruption and replacement as a feasible approach for mutagenesis of *Campylobacter jejuni*. *J. Bacteriol.* **170**:1704-1708.
29. **Labigne-Roussel A, Harel J, Tompkins L.** 1987. Gene transfer from *Escherichia coli* to *Campylobacter* species: development of shuttle vectors for genetic analysis of *Campylobacter jejuni*. *J. Bacteriol.* **169**:5320-5323.
30. **Larsen JC, Szymanski C, Guerry P.** 2004. N-linked protein glycosylation is required for full competence in *Campylobacter jejuni* 81-176. *J. Bacteriol.* **186**:6508-6514.
31. **McNally DJ, Jarrell HC, Li J, Khieu NH, Vinogradov E, Szymanski CM, Brisson JR.** 2005. The HS:1 serostrain of *Campylobacter jejuni* has a complex teichoic acid-like capsular polysaccharide with nonstoichiometric fructofuranose branches and O-methyl phosphoramidate groups. *FEBS J.* **272**:4407-4422.

32. **McNally DJ, Lamoureux MP, Karlyshev AV, Fiori LM, Li J, Thacker G, Coleman RA, Khieu NH, Wren BW, Brisson JR, Jarrell HC, Szymanski CM.** 2007. Commonality and biosynthesis of the *O*-methyl phosphoramidate capsule modification in *Campylobacter jejuni*. *J. Biol. Chem.* **282**:28566-28576.
33. **Miller JF, Dower WJ, Tompkins LS.** 1988. High-voltage electroporation of bacteria: Genetic transformation of *Campylobacter jejuni* with plasmid DNA. *Proc. Natl. Acad. Sci. U. S. A.* **85**:856-860.
34. **Miller WG, Bates AH, Horn ST, Brandl MT, Wachtel MR, Mandrell RE.** 2000. Detection on surfaces and in Caco-2 cells of *Campylobacter jejuni* cells transformed with new *gfp*, *yfp*, and *cfp* marker plasmids. *Appl. Environ. Microbiol.* **66**:5426-5436.
35. **Mixer PF, Klena JD, Flom GA, Siegesmund AM, Konkel ME.** 2003. *In vivo* tracking of *Campylobacter jejuni* by using a novel recombinant expressing green fluorescent protein. *Appl. Environ. Microbiol.* **69**:2864-2874.
36. **Muir ME, Ballesteros M, Wallace BJ.** 1985. Respiration rate, growth rate and the accumulation of streptomycin in *Escherichia coli*. *J. Gen. Microbiol.* **131**:2573-2579.
37. **Muir ME, Hanwell DR, Wallace BJ.** 1981. Characterization of a respiratory mutant of *Escherichia coli* with reduced uptake of aminoglycoside antibiotics. *Biochim. Biophys. Acta.* **638**:234-241.
38. **Poly F, Read TD, Chen YH, Monteiro MA, Serichantalergs O, Pootong P, Bodhidatta L, Mason CJ, Rockabrand D, Baqar S, Porter CK, Tribble D, Darsley M, Guerry P.** 2008. Characterization of two *Campylobacter jejuni* strains for use in volunteer experimental-infection studies. *Infect. Immun.* **76**:5655-5667.
39. **Poulin MB, Nothaft H, Hug I, Feldman MF, Szymanski CM, Lowary TL.** 2010. Characterization of a bifunctional pyranose-furanose mutase from *Campylobacter jejuni* 11168. *J. Biol. Chem.* **285**:493-501.
40. **Promega.** 2010. pGEM®-T and pGEM®-T Easy Vector Systems: Instruction for use of products A1360, A1380, A3600 AND A3610. Promega Corporation, Madison, WI.
41. **Ribardo DA, Bingham-Ramos LK, Hendrixson DR.** 2010. Functional analysis of the RdxA and RdxB nitroreductases of *Campylobacter jejuni* reveals that mutations in *rdxA* confer metronidazole resistance. *J. Bacteriol.* **192**:1890-1901.

42. **Rose A, Kay E, Wren BW, Dallman MJ.** 2011. The *Campylobacter jejuni* NCTC11168 capsule prevents excessive cytokine production by dendritic cells. *Med. Microbiol. Immunol.*
43. **Sagara H, Mochizuki A, Okamura N, Nakaya R.** 1987. Antimicrobial resistance of *Campylobacter jejuni* and *Campylobacter coli* with special reference to plasmid profiles of Japanese clinical isolates. *Antimicrob. Agents Chemother.* **31**:713-719.
44. **Sambrook J, Russell DW (eds.)**, 2001. *Molecular cloning: A laboratory manual*. Cold Spring Harbor Laboratory Press, Cold Spring Harbor, NY.
45. **Serino L, Virji M.** 2002. Genetic and functional analysis of the phosphorylcholine moiety of commensal *Neisseria* lipopolysaccharide. *Mol. Microbiol.* **43**:437-448.
46. **Sohlenkamp C, Lopez-Lara IM, Geiger O.** 2003. Biosynthesis of phosphatidylcholine in bacteria. *Prog. Lipid Res.* **42**:115-162.
47. **Stahl M, Friis LM, Nothaft H, Liu X, Li J, Szymanski CM, Stintzi A.** 2011. L-fucose utilization provides *Campylobacter jejuni* with a competitive advantage. *Proc. Natl. Acad. Sci. U. S. A.* **108**:7194-7199.
48. **Szymanski CM, Michael FS, Jarrell HC, Li J, Gilbert M, Larocque S, Vinogradov E, Brisson JR.** 2003. Detection of conserved *N*-linked glycans and phase-variable lipooligosaccharides and capsules from campylobacter cells by mass spectrometry and high resolution magic angle spinning NMR spectroscopy. *J. Biol. Chem.* **278**:24509-24520.
49. **Taber H, Halfenger GM.** 1976. Multiple-aminoglycoside-resistant mutants of *Bacillus subtilis* deficient in accumulation of kanamycin. *Antimicrob. Agents Chemother.* **9**:251-259.
50. **Taber HW, Mueller JP, Miller PF, Arrow AS.** 1987. Bacterial uptake of aminoglycoside antibiotics. *Microbiol. Rev.* **51**:439-457.
51. **Thornton JA, Durick-Eder K, Tuomanen EI.** 2010. Pneumococcal pathogenesis: "innate invasion" yet organ-specific damage. *J. Mol. Med. (Berl).* **88**:103-107.
52. **Wang Y, Taylor DE.** 1990. Chloramphenicol resistance in *Campylobacter coli*: Nucleotide sequence, expression, and cloning vector construction. *Gene.* **94**:23-28.

53. **Wang Y, Taylor DE.** 1990. Natural transformation in *Campylobacter* species. *J. Bacteriol.* **172**:949-955.
54. **Wassenaar TM, Fry BN, van der Zeijst BA.** 1993. Genetic manipulation of *Campylobacter*: Evaluation of natural transformation and electro-transformation. *Gene.* **132**:131-135.
55. **Weiser JN, Shchepetov M, Chong ST.** 1997. Decoration of lipopolysaccharide with phosphorylcholine: A phase-variable characteristic of *Haemophilus influenzae*. *Infect. Immun.* **65**:943-950.
56. **Wosten MM, Boeve M, Koot MG, van Nuenen AC, van der Zeijst BA.** 1998. Identification of *Campylobacter jejuni* promoter sequences. *J. Bacteriol.* **180**:594-599.
57. **Yao R, Alm RA, Trust TJ, Guerry P.** 1993. Construction of new *Campylobacter* cloning vectors and a new mutational *cat* cassette. *Gene.* **130**:127-130.
58. **Zhang XS, Blaser MJ.** 2012. Natural transformation of an engineered *Helicobacter pylori* strain deficient in type II restriction endonucleases. *J. Bacteriol.* **194**:3407-3416.

CHAPTER 3

Phosphorylated modifications of the capsular polysaccharides and lipooligosaccharides affect serum resistance of *Campylobacter upsaliensis*

3.1 Introduction

Campylobacter upsaliensis is commonly isolated from normal and diarrheic feces of dogs and cats (5). In humans, it is most commonly linked to cases of self-limiting gastroenteritis, however there are multiple reports of systemic disease, such as extra-intestinal infections of the breast and placenta (1, 5, 6, 14, 22). Ho *et. al.* recorded the presence of anti-*C. upsaliensis* LOS-GM1 antibodies in a Guillain-Barré patient's serum while others have noted the presence of *C. upsaliensis* in blood cultures (23, 26, 33). Survival in the bloodstream is reliant on the bacterium's ability to evade the host's adaptive and innate immune response. This is directly related to the inherent immunogenicity of bacterial surface structures and bacterial modification of these moieties to diminish their reactivity. As characterized in Chapter 2, *C. upsaliensis* strain RM3195 modifies its capsular polysaccharide (CPS) with phosphoramidate (MeOPN) and its lipooligosaccharide (LOS) with phosphocholine (PCho). These modifications are both located on the bacterial surface, suggesting a potential role in serum survival.

PCho is an immunoreactive structure expressed on cell surface residues of a variety of commensals and opportunistic pathogens present in the human oropharynx and nasopharynx mucosa (16, 41). Expression of PCho directly results in decreased bacterial survival in human serum through host clearance by both adaptive and innate immunity (45). Anti LOS-PCho-specific immunoglobulin G (IgG) as well as the acute-phase serum protein C-reactive

protein (CRP), bind bacteria via their PCho modified residues, which marks them for subsequent uptake and phagocytosis by macrophages (7, 44, 45). CRP can also mediate bacterial clearance via C1q deposition and activation of complement by the classical pathway (37, 42). The presence of PCho resulted in decreased serum survival of both *Neisseria meningitidis* and *Haemophilus influenzae* compared to their PCho deletion mutants, and the binding of CRP to the PCho-modified pili of *N. meningitidis* was both concentration dependent and specific (7, 44, 45). CRP also acted as an opsonin for *N. meningitidis*, and bacterial phagocytosis by human macrophages and granulocytes was increased for the PCho modified strain (7). Although PCho display is a common strategy used by the bacterial communities in the respiratory mucosa, the modification of *C. upsaliensis* LOS with PCho is first reported for an intestinal pathogen. It is unknown if PCho display will provide *C. upsaliensis* with the same serum phenotypes as *H. influenzae*, which also modifies its LOS with PCho. It is also important to note that in contrast to the established role of PCho in multiple bacteria, the role of MeOPN is still unclear.

In *Campylobacter jejuni*, removal of sialic acid from the LOS core or loss of the CPS high molecular weight glycan increases bacterial sensitivity to serum (3, 18, 21). CPS thwarts the bactericidal effects of complement through prevention of deposition of membrane attack complexes on the bacterial surface (30). However, CPS is an immunoreactive moiety and the main serodeterminant of the Penner serotyping scheme (24). Karlyshev and colleagues reported that five

out of the six acapsular mutants generated in their study lost the ability to be serotyped. It is important to note that Penner serotyping is not a direct reflection of the pathogenicity and individual isolates within a serogroup will display varying disease phenotypes and reactivity to environmental pressures. *C. jejuni* isolates 11168 and 84-25 both belong to the HS2 Penner serogroup but demonstrate markedly different complement-mediated serum sensitivities (25). This indicates that modification of CPS and LOS, which are independent of Penner serogrouping (and thus carbohydrate structure), influence strain survival in serum.

In this study, we demonstrate that *C. upsaliensis* is susceptible to classically activated complement-mediated serum killing in a PCho-dependent mechanism. Moreover, we provide evidence that MeOPN acts as a protective moiety shielding *C. upsaliensis* from the bactericidal effects of human serum.

3.2 Material and Methods

3.2.1 Bacterial strains and growth conditions

The bacterial strains used in this study are listed in Table 3.1. The *C. upsaliensis* strain RM3195 (ATCC BAA-1059, Manassas, VA, USA) was originally obtained from the feces of a 4-year-old Guillain-Barré syndrome patient and its genome later sequenced by Fouts and colleagues (13). The construction and phenotypical testing of the MeOPN mutant, *Cup_0802::cat*, and the PCho mutant, *licC::cat*, are described in Chapter 2.

Table 3.1 Strains used in this study.

Strain	Description	Reference or source
RM3195 wt	Human clinical isolate	(13)
RM3195 <i>licC::cat</i>	RM3195; <i>licC</i> mutant, Cm ^R	Chapter 2
RM3195 <i>Cup_0802::cat</i>	RM3195; <i>CUP_0802</i> mutant, Cm ^R	Chapter 2
RM1488	Human clinical isolate	This study
RM3810	Feline veterinary isolate	This study
RM3940	Human clinical isolate	This study
RM3941	Human clinical isolate	This study
RM3950	Canine veterinary isolate	This study
RM4252	Human clinical isolate	This study
RM4253	Human clinical isolate	This study
RM4446	Feline veterinary isolate	This study
RM4456	Canine veterinary isolate	This study
RM3778	Human clinical isolate	This study
RM4248	Human clinical isolate	This study
RM4251	Human clinical isolate	This study

All *C. upsaliensis* strains were routinely grown on Blood Agar Base No. 2 (Oxoid, Basingstoke, Hampshire, UK), which was supplemented with 7 % Horse Blood (Quadfive, Ryegate, MT) and 1 % Yeast Extract (BD/Bacto, Franklin Lakes, NJ, USA) and grown at 37 °C under microaerobic conditions (85 % N₂, 10 % CO₂ and 5 % O₂). Chloramphenicol (Cm) (Sigma-Aldrich, Oakville, ON) supplemented the agar plates at a final concentration of 20 µg ml⁻¹.

For biphasic growth, upright 25 cm² tissue culture flasks were filled with 5 ml of Brain Heart Infusion (BD/Difco) supplemented with 1% Yeast Extract (wt vol⁻¹) (BHIY) and 1.5% agar (wt vol⁻¹) with 5 ml of BHIY broth added on top.

RM3195 from 16 h - old plates was used to inoculate upright flasks that were then incubated at 37 °C under microaerobic conditions with shaking at 140 rpm.

Antibiotics were not added to biphasic media. RM3195 did not grow in biphasic flasks that were lying down and to the organism requires shaking to grow in broth.

3.2.2 Serum susceptibility assay

The serum susceptibility assays were performed as described by Blaser and colleagues with modifications (4). *C. upsaliensis* strains were grown overnight in biphasic media, pelleted (4,000 x g, 5 min), then resuspended in HEPES buffer, pH = 7.4. This bacterial resuspension was then diluted to a final concentration of 1×10^7 CFU ml⁻¹ in 10% (vol vol⁻¹) normal human serum (Innovative Research, distributed by Cedarlane Laboratories Ltd., Burlington, ON) in HEPES buffer. The bacteria-serum mixture was incubated in 24-well plates at 37 °C under microaerobic conditions, with shaking (90 rpm) for 2 h. This suspension was serially diluted, plated and CFUs counted after 48 h incubation. Bacterial survival in HEPES as well as survival in serum heated at 56 °C for 45 min to inactivate complement, were determined. Values are percentages of the ratio of bacterial survival in serum over survival in heat-inactivated serum. Serum survival was repeated in three independent experiments, using triplicate wells, and plotted with standard deviations.

3.2.3 *Western transfer and immunoblotting*

Whole cell lysates were prepared by resuspending an overnight culture in phosphate buffered saline (PBS) and standardizing each 1 ml sample to an $OD_{600} = 2$. Samples were then pelleted and resuspended in 150 μ l of PBS. For proteinase K-, RNase A-, DNase I- treated samples, the resuspension was first subjected to 100 μ g ml^{-1} DNase I and 50 μ g ml^{-1} RNase A digestion at 37 °C for 1 h, followed by 100 μ g ml^{-1} proteinase K digestion at 55 °C for 1 h. Laemmli protein loading buffer was added and samples boiled at 100 °C for 5 min. Whole cell lysates were separated in a 15 % SDS-PAGE gel and then transferred onto polyvinylidene difluoride (PVDF) membranes (Millipore, Billerica, MA, USA). The PVDF membrane was blocked overnight with 5 % bovine serum albumin (BSA) (Bioshop, Burlington, ON) in PBS-0.1% Tween (PBST). Immunoblotting of the membrane was carried using 1:5,000 dilution of the monoclonal antibody TEPC-15 (Sigma) in PBST with 1% BSA for 1h followed by another 1h incubation (after PBST washes) in 1:5,000 dilution of rabbit anti-mouse immunoglobulin A antibody conjugated to alkaline phosphatase (Santa Cruz Biotechnology, Santa Cruz, CA, USA). The blot was developed with nitroblue tetrazolium-5-bromo-4-chloro-3-indolylphosphate (NBT-BCIP) solution (Roche).

3.2.4 *CPS analysis by high resolution magic angle spinning NMR (HR-MAS NMR)*

Bacteria were grown overnight on a Blood agar plate, harvested with a sterile loop and then resuspended in 1 ml of 10 % sodium azide in PBS prepared

with 99.9 % D₂O for 1 h at room temperature. Cells were pelleted by centrifugation (5000 x g for 5 min), supernatant discarded and cell pellet washed with PBS in 99.9 % D₂O. This wash procedure was repeated three times and the resulting pellet was resuspended in 10 µl of D₂O containing 0.1% 3-(trimethylsilyl)propionic-2,2,3,3-*d*₄ acid sodium salt (TSP). Forty µl of cell suspension was loaded into a 4 mm nano NMR tube (Varian Inc., Palo Alto, USA).

HR-MAS NMR experiments were performed with a Varian/Agilent VNMRS 600 MHz spectrometer equipped with a Varian 4 mm indirect detection gradient nano-NMR probe with a broadband decoupling coil. Samples were spun a 2.5 – 3 kHz, and spectra recorded at ambient temperature (23 °C). HR-MAS experiments were performed with suppression of the HOD signal using presaturation. ¹H NMR spectra were acquired using the Carr-Purcell-Meiboom-Gill pulse sequence (900-(τ-180-τ)_n acquisition) to remove broad signals originating from lipids and solid-like materials and were typically obtained using 256 transients. One-dimensional ¹H - ³¹P HSQC spectra were acquired using the standard Varian HSQC pulse sequence with one-dimensional spectra representing the first increment of the standard HSQC experiment. All ¹H NMR spectra were referenced to an internal TSP standard (δ_H 0.00 ppm).

3.2.5 *C-reactive protein- (CRP) alkaline phosphatase conjugation and binding assay*

This CRP binding assay was designed based on a method described by Culley *et al.* (8). Purified CRP (The Binding Site, San Diego, CA) was first conjugated to alkaline phosphatase (AP) using glutaraldehyde in a one-step protocol (2). CRP-AP was then diluted to $20 \mu\text{g ml}^{-1}$ in a PBS 1 mM CaCl_2 solution and $25 \mu\text{l}$ was added to 96-well plates containing $50 \mu\text{l}$ baked dry 1×10^{10} CFU RM3195 wt that was previously blocked for 1 h with BSA (Bioshop). Plates were then incubated in the dark with shaking for 2 h, washed three times with PBS and once with 0.1 M bicarbonate buffer, pH 9.6. Each well was developed with $50 \mu\text{l}$ of *p*-nitrophenylphosphate (Sigma-Aldrich) at 1 mg ml^{-1} (wt vol^{-1}) in 0.1 M bicarbonate buffer pH 9.6 containing 2 mM MgCl_2 . Plates were incubated in the dark for a further hour and read at 405 nm on a microplate reader.

3.3 Results

3.3.1 *Phosphorylated modifications display affects on C. upsaliensis survival in human serum*

A collection of *C. upsaliensis* strains isolated from human, canine and feline origin were screened for their ability to survive in human serum and if this survival was affected by the presence of PCho and/or MeOPN. From the 13 strains screened, five expressed PCho, as detected by the PCho-specific antibody TEPC-15, while 12 expressed MeOPN, as detected by HR-MAS NMR, utilizing

both CPMG and HSQC pulse sequences (Figure 3.1). Survival in human serum appears to be reliant on more factors than PCho or MeOPN display alone, and does not correlate with source of isolate origin. For the PCho-negative strains, some isolates such as RM3941, RM4252, RM4446 and RM4456 appear to be resistant to serum, while RM3940 and RM3950 are almost entirely killed (Figure 3.1). Interestingly, all of the PCho-modified human isolates were susceptible to serum killing with percent survival ranging from 0 to 26% (Figure 3.1).

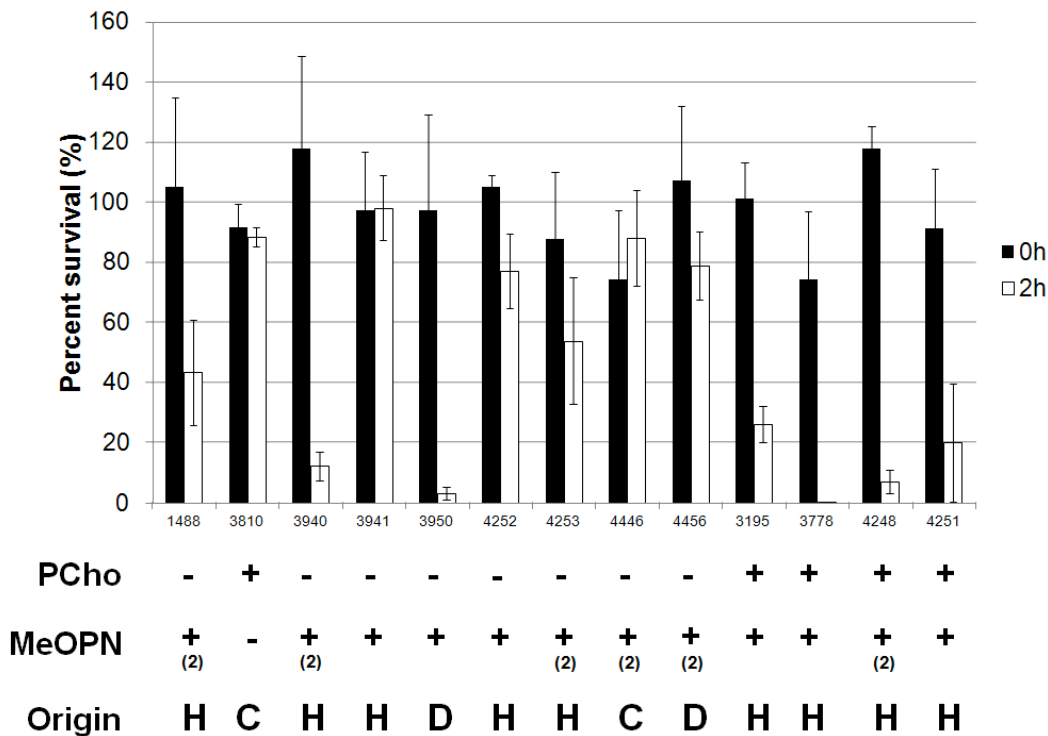

Figure 3.1 Resistance to human serum is not reflective of presence or absence of PCho, MeOPN or source of strain origin. Percent survival of seven *C. upsaliensis* subspecies upsaliensis, after 2h incubation in 10% human serum. Values are percentages with 100% equal to survival in heat-inactivated serum \pm standard deviations. All serum survival values are results from three separate trials done in

triplicate. PCho expression was detected with the MAb TEPC-15 on whole-cell lysates separated by SDS-15% PAGE. MeOPN expression was detected by HR-MAS NMR utilizing both CPMG and HSQC pulse sequences. *C. upsaliensis* strains were isolated from human (H), feline (C) or canine (D) sources. (+), contains PCho and/or MeOPN; (-), not present; (2), presence of two MeOPN signals.

3.3.2 *MeOPN and PCho conversely affect C.upsaliensis RM3195 serum survival*

The contribution of MeOPN and PCho to *C. upsaliensis* serum survival was further investigated by the construction of two biosynthetic mutants in strain RM3195, a human MeOPN- and PCho- modified isolate. Percent survival after a 2 h exposure to 10% normal human serum was significantly higher in *licC::cat* compared to RM3195 wt and *Cup_0802::cat* (Figure 3.2A). This is consistent with previous studies conducted with *N. meningitidis* and *H. influenzae* that observed an increase in serum resistance when PCho is not expressed (7, 44). Through a comparison of *licC::cat* to RM3195 wt percent survival, it appears that PCho display is responsible for approximately ~25% of overall RM3195 serum killing.

Interestingly, *Cup_0802::cat* demonstrates a significant decrease in serum resistance, suggesting MeOPN may play a protective role in RM3195 serum survival (Figure 3.2A). *Cup_0802::cat* is extremely susceptible to serum. This could be in part due to the removal of MeOPN moiety from the CPS, potentially

allowing more exposure to the immunoreactant PCho-modified LOS, and thereby increasing *Cup_0802::cat* serum susceptibility.

Incubation of all three strains in serum heated at 55 °C for 45 min or in HEPES buffer instead of serum, did not affect bacterial survival (Figure 3.2B and 3.2C).

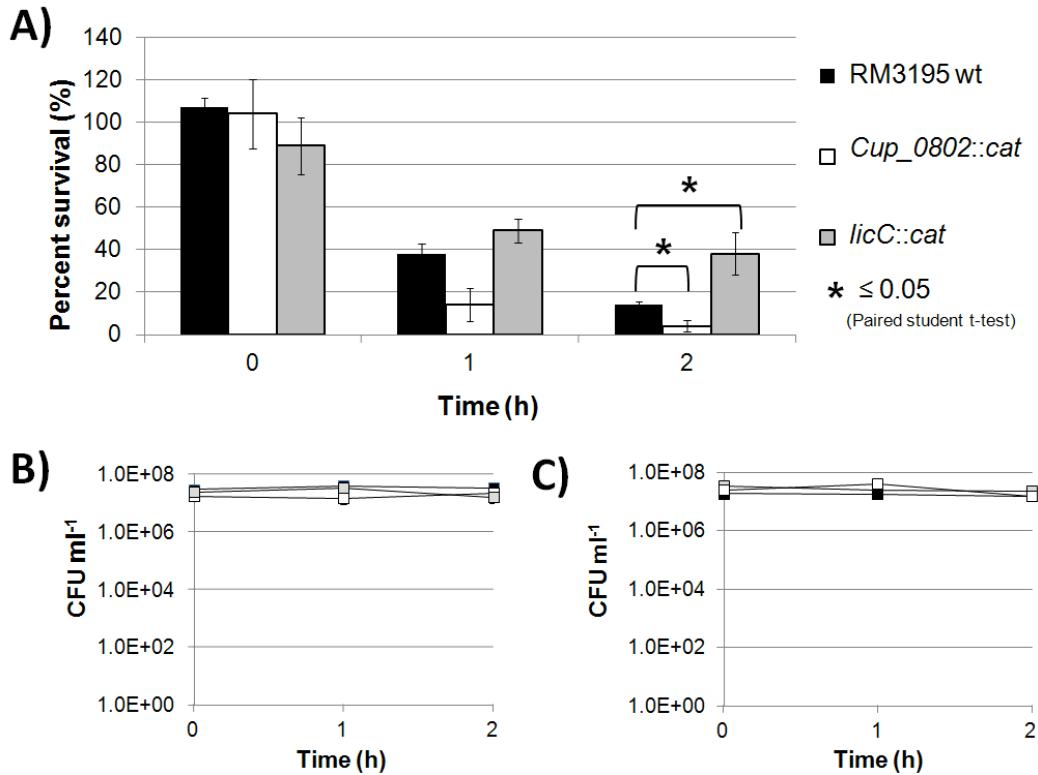

Figure 3.2 *C. upsaliensis* resistance to the bactericidal activity of human serum.

A) Percent survival of RM3195 wt, *Cup_0802::cat* and *licC::cat* in 10% normal human serum. Values are percentages with 100% equal to survival in heat-inactivated serum \pm standard deviations. **B)** Survival of RM3195 wt, *Cup_0802::cat* and *licC::cat* in 10% normal human serum heat inactivated at 56

°C for 45 min. C) Survival of RM3195 wt, *Cup_0802::cat* and *licC::cat* in HEPES buffer. All values are results from two separate trials done in triplicate.

3.3.3 *MeOPN and PCho alter C. upsaliensis RM3195 serum susceptibility via the classical complement pathway*

Serum resistance assays in the presence of 10 mM ethylene glycol tetraacetic acid (EGTA) were carried out to discover the pathway of complement cascade activation that was responsible for the PCho-mediated killing and the MeOPN-related protection of RM3195. The addition of EGTA blocks classical complement pathway activation, but the activation of complement components C3PA and C3 can occur normally (12). RM3195 wt survival increased significantly, while there was no significant difference in survival between *licC::cat* with or without 10 mM EGTA (Figure 3.3). There was also no difference between RM3195 wt and *licC::cat* percent survival in the presence of 10 mM EGTA, indicating that classical complement cascade activation related serum killing of RM3195 is reliant on the presence of PCho (Figure 3.3). This was also observed in *H. influenzae* where addition of 50 mM EGTA blocked classical activation and subsequent serum killing of a PCho-displaying isolate (44).

Survival of *Cup_0802::cat* was increased to RM3195 wt levels in the presence of 10 mM EGTA indicating the protective feature of MeOPN involves interference with the classical activation pathway (Figure 3.3). It is also possible

through the addition of EGTA, as a divalent cationic chelator, its presence interfered with the binding of an acute-phase protein that in turn prevented classical complementation activation.

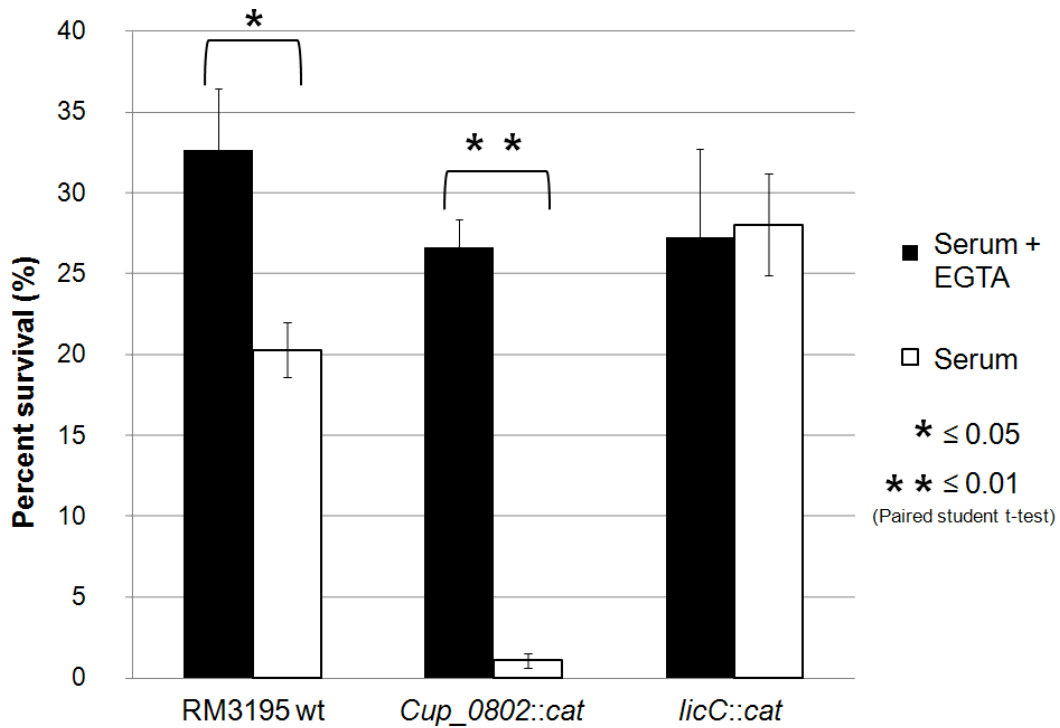

Figure 3.3 *C. upsaliensis* resistance to the bactericidal activity of human serum is altered in the presence of EGTA. Percent survival of RM3195 wt, *Cup_0802::cat* and *licC::cat* in 10% normal human serum with or without 10mM EGTA after 2h incubation. Values are percentages with 100% equal to survival in heat-inactivated serum \pm standard deviations. All values are results from two separate trials in done triplicate.

3.3.4 *C-reactive protein (CRP) does not bind to C. upsaliensis*

The possible involvement of CRP in the serum survival phenotypes observed for MeOPN and PCho was examined through a chemical conjugation alkaline phosphatase binding assay. Based on multiple experiments with conjugated CRP, (different conjugation times, protein concentrations and glutaraldehyde concentrations), there was no significant difference in CRP binding between RM3195 wt and the two mutants (Figure 3.4). It is interesting to note that for the 2 h conjugation, *licC::cat* did appear to bind less CRP than RM3195 wt (Figure 4), but this difference was not significant and the maximum OD₄₀₅ measured for all strains was approximately 20% lower than the OD₄₀₅ in other experiments in which CRP bound to their substrate (7, 8).

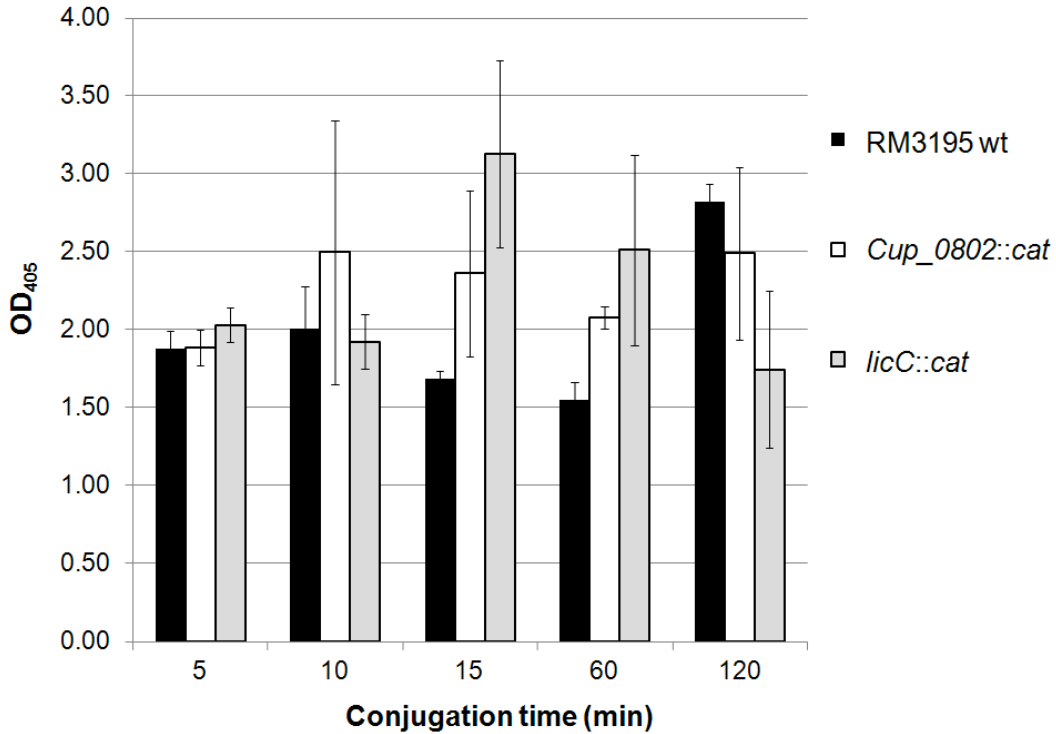

Figure 3.4 CRP binding to RM3195. CRP was chemically conjugated to alkaline phosphatase for 5 min to 2 h, purified and co-incubated with RM3195 strains. Data is expressed as the average absorbances at 405 nm from three replicate experiments plus standard deviations of the mean.

3.4 Discussion

In this study, we demonstrate that phosphorylated modifications of surface structures are widespread among isolates of *C. upsaliensis*. Expression of MeOPN was conserved among 12 out of the 13 *C. upsaliensis* isolates examined (Figure 3.1). The MeOPN biosynthetic pathway is widespread among the Epsilon proteobacteria and conserved in a number of *Campylobacter* and *Helicobacter* species (Figure 2.1). In a study by McNally and colleagues, 68% of the 63 *C.*

jejuni strains screened expressed the MeOPN modification and of those, MeOPN was present in 80% of Guillain-Barré syndrome strains and 82% of enteritis isolates (28). HR-MAS NMR screens of chicken cecal contents revealed MeOPN was expressed in the avian gastrointestinal tract (28, 34). If the *C. jejuni* results could be related to *C. upsaliensis*, this indicates that MeOPN is a prominent structural modification of the CPS, and it is most likely important for *C. upsaliensis* survival in commensal and pathogenic environments.

PCho decoration of *C. upsaliensis* was not as prevalent as the MeOPN modification among the strains examined (Figure 3.1). This, in correlation with its low prevalence among other *Campylobacter species* and intestinal pathogens in general, indicates PCho-decorated LOS may provide *C. upsaliensis* with a selective advantage under certain conditions. *C. jejuni* strains often utilize specialized pathways that allow them to take advantage of unique environmental niches. For example, fucose uptake enhances the growth of *C. jejuni* as well as provides it with a competitive advantage in the piglet disease model compared to a fucose permease mutant (35). However, the genes required for fucose uptake are only present in a subset of *C. jejuni* strains, including NCTC 11168 and RM1221. They are absent from other well-characterized pathogenic *C. jejuni* isolates such as 81-176 and 81116 (35). This strain-to-strain variability is also observed in the *ptm* locus, which is involved in *C. jejuni* O-linked flagellar glycosylation. *C. jejuni* strain 81-176 is missing 24 of the 45 genes found between *cj1293* and *cj1337*, which are present in *C. jejuni* NCTC 11168 (17, 39). An acetamidino

structural variant of pseudaminic acid is catalyzed by *cj1316*, and mutation of this modification in 81-176 results in a decrease in adherence and invasion of intestinal epithelial cells, as well as attenuation in a ferret diarrheal disease model (19, 39, 40). Although the PCho modification was only present in five out of the 12 *C. upsaliensis* strains screened, its expression most likely provides a competitive edge in a selective environmental niche, such as colonization or invasion as observed in the respiratory mucosal pathogens (9, 11, 36). This hypothesis correlates with a genetic screen of over 100 European and South African *C. upsaliensis* isolates, which demonstrated a strong association between the presence of PCho biosynthetic genes and clinical symptoms (13).

Presentation of MeOPN and PCho alter *C. upsaliensis* serum survival by two different mechanisms. It was hypothesized that due to the similarity in structure, and homology between biosynthetic pathways, each modification would alter serum survival by a parallel means. However, PCho displays decreased *C. upsaliensis* serum survival while MeOPN displays increased survival (Figure 3.2). This is consistent with preliminary data from *C. jejuni* NCTC 11168 and 81-176, which both demonstrate a MeOPN mutant is more susceptible to serum compared to wild type (van Alphen LB, personal communication). The protective effect MeOPN provides from serum may account for the prevalence for which MeOPN is expressed within the Epsilon proteobacteria. However, based on the screen of the *C. upsaliensis* isolates, MeOPN alone does not protect *C. upsaliensis* from the bactericidal affects of serum (Figure 1). MeOPN-expressing isolates range from

serum resistant to less than 5% survival. This indicates serum survival is multi-factorial, and although MeOPN provides a protective role in RM3195, its presence alone does not shield the bacteria from serum-based recognition and destruction via other immunoreactant molecules. The surface of *Campylobacter* is incredibly complex, and in *C. jejuni* it is estimated that there are greater than 700 different possible CPS structures, which can add structural rigidity or mask conserved sugar residues (20). These combinations are created through phase variation, a method that allows bacteria to survive rapidly changing environments through random switching of the frequency of certain phenotypes. *C. upsaliensis* is especially amendable to this process due to the presence of 209 homopolymeric repeats, either poly G or poly C tracts, within its genome (13). This is approximately five times as many poly G:C tracts as *C. jejuni* RM1221 and 22 times as many as *C. coli* RM2228. The majority of these variable regions lie in ORFs associated with the biosynthesis and modification of the CPS and LOS. This indicates that although the genome composition of the *C. upsaliensis* strains screened may be the same, their surface make-up can be entirely different depending on their origin of isolation and the selective pressures the strain underwent surviving in the host environment. Thus despite expression of MeOPN and its inherent protective effect against serum, other individual *C. upsaliensis* surface modifications may impact each strain's serum survival, resulting in either serum resistance or susceptibility.

The PCho-dependent killing observed in this study may account for its lower distribution in the *C. upsaliensis* isolates screened and interestingly, it is consistent with the serum susceptibility profile displayed by *H. influenzae* (43). *H. influenzae* PCho modified LOS is recognized by the acute phase serum protein CRP (44). Once bound, the PCho-LOS-CRP complex initiates the classical complement cascade through binding of C1q, facilitating bacterial removal via complement (37, 42). CRP-PCho-mediated clearance has also been implicated for *S. pneumonia* and *N. meningitidis* (7, 38). For these bacteria, CRP promotes bacterial clearance by opsonization and subsequent removal by a phagocyte. Studies examining the interaction of complement with CRP, demonstrate complement activation by CRP is restricted to C1, C4, C2 and C3 (31). Factor H binds to CRP complexed with a PCho substrate and prevents activation of the alternative pathway as well as formation of C5 convertase. This minimal generation of C5a and C5b-9, led the authors to hypothesize that CRP acted in an opsonization capacity compared to formation of the membrane attack complex (31). However, *H. influenzae* binds CRP in a calcium-dependent manner, and its clearance is CRP and complement dependent, as demonstrated by increased bacterial survival in CRP-depleted serum (44). It was hypothesized that *C. upsaliensis* serum susceptibility was also mediated in a CRP-PCho-dependent mechanism. RM3195 wt demonstrated an increased serum survival in the presence of EGTA (Figure 3), which blocks classical complementation pathway activation, as well as can act as a divalent cationic chelator, which would also

disrupt the calcium-dependent binding of PCho (12). This led us to examine if CRP was involved in *C. upsaliensis* serum susceptibility. Utilizing two classical binding assays, it appeared that CRP does not bind to *C. upsaliensis* whole cells, CPS or LOS, removing CRP as a candidate for the observed serum phenotype.

This inability to bind either protein indicates MeOPN and PCho could be acting by a novel mechanism not yet to be described in literature. The ability of CRP to bind *H. influenzae* PCho-modified LOS is position dependent (27). Genetic polymorphisms in LicD between *H. influenzae* strains Rd and Eagen modify heptose I or heptose III, respectively with PCho. Strains expressing the heptose III modification were serum susceptible and bound CRP regardless of strain background, while the heptose I modification were serum resistant and did not bind CRP. The structures of the LOS and CPS are currently unknown for *C. upsaliensis* and the PCho modification could be inaccessible to CRP due to its proximity to Lipid A. The genome of *C. upsaliensis* RM3195 contains various genomic rearrangements and incorporation of novel ORFs into its LOS and CPS biosynthetic clusters (13). This indicates that both these structures could be extremely different than the current LOS and CPS structures reported for *C. jejuni*, *C. fetus*, *C. coli* and *C. lari* (15).

Currently in collaboration with Roger Ashmus from Dr. Todd Lowary's laboratory, we are preparing PCho-, MeOPN-, CPS- and LOS- conjugated sepharose. Through affinity chromatography of serum, we will be able to elucidate the serum-based moieties responsible for *C. upsaliensis* RM3195 PCho-

related killing and MeOPN-mediated protection. We believe through use of a non-selective method such as affinity chromatography, we will be able to uncover the protein(s) responsible for the serum phenotype observed in this study.

3.5 Acknowledgments

The authors would like to thank Dr. William Miller for the gift of the *C. upsaliensis* strains utilized in this report.

3.6 Literature cited

1. **Allos BM.** 1997. Association between *Campylobacter* infection and Guillain-Barré syndrome. *J. Infect. Dis.* **176 S2:**S125-8.
2. **Avrameas S.** 1969. Coupling of enzymes to proteins with glutaraldehyde. Use of the conjugates for the detection of antigens and antibodies. *Immunochemistry.* **6:**43-52.
3. **Bacon DJ, Szymanski CM, Burr DH, Silver RP, Alm RA, Guerry P.** 2001. A phase-variable capsule is involved in virulence of *Campylobacter jejuni* 81-176. *Mol. Microbiol.* **40:**769-777.
4. **Blaser MJ, Smith PF, Kohler PF.** 1985. Susceptibility of *Campylobacter* Isolates to the Bactericidal Activity of Human-Serum. *J. Infect. Dis.* **151:**227-235.
5. **Bourke B, Chan VL, Sherman P.** 1998. *Campylobacter upsaliensis*: Waiting in the wings. *Clin. Microbiol. Rev.* **11:**440-449.
6. **Carter JE, Cimolai N.** 1996. Hemolytic-uremic syndrome associated with acute *Campylobacter upsaliensis* gastroenteritis. *Nephron.* **74:**489.
7. **Casey R, Newcombe J, McFadden J, Bodman-Smith KB.** 2008. The acute-phase reactant C-reactive protein binds to phosphorylcholine-expressing *Neisseria meningitidis* and increases uptake by human phagocytes. *Infect. Immun.* **76:**1298-1304.
8. **Culley FJ, Bodman-Smith KB, Ferguson MA, Nikolaev AV, Shantilal N, Raynes JG.** 2000. C-reactive protein binds to phosphorylated carbohydrates. *Glycobiology.* **10:**59-65.
9. **Cundell DR, Gerard NP, Gerard C, Idanpaan-Heikkila I, Tuomanen EI.** 1995. *Streptococcus pneumoniae* anchor to activated human cells by the receptor for platelet-activating factor. *Nature.* **377:**435-438.
10. **de Haas CJ, van Leeuwen EM, van Bommel T, Verhoef J, van Kessel KP, van Strijp JA.** 2000. Serum amyloid P component bound to Gram-negative bacteria prevents lipopolysaccharide-mediated classical pathway complement activation. *Infect. Immun.* **68:**1753-1759.
11. **Fillon S, Soulis K, Rajasekaran S, Benedict-Hamilton H, Radin JN, Orihuela CJ, El Kasmi KC, Murti G, Kaushal D, Gaber MW, Weber JR, Murray PJ, Tuomanen EI.** 2006. Platelet-activating factor receptor and innate

immunity: Uptake of Gram-positive bacterial cell wall into host cells and cell-specific pathophysiology. *J. Immunol.* **177**:6182-6191.

12. **Forsgren A, Mclean RH, Michael AF, Quie PG.** 1975. Studies of the alternate pathway in chelated serum. *J. Lab. Clin. Med.* **85**:904-912.

13. **Fouts DE, Mongodin EF, Mandrell RE, Miller WG, Rasko DA, Ravel J, Brinkac LM, DeBoy RT, Parker CT, Daugherty SC, Dodson RJ, Durkin AS, Madupu R, Sullivan SA, Shetty JU, Ayodeji MA, Shvartsbeyn A, Schatz MC, Badger JH, Fraser CM, Nelson KE.** 2005. Major structural differences and novel potential virulence mechanisms from the genomes of multiple *Campylobacter* species. *PLoS Biol.* **3**:e15.

14. **Gaudreau C, Lamothe F.** 1992. *Campylobacter upsaliensis* isolated from a breast abscess. *J. Clin. Microbiol.* **30**:1354-1356.

15. **Gilbert M, Parker CT, Moran AP.** 2008. *Campylobacter jejuni* lipooligosaccharides: Structure and biosynthesis, p. 483. In I. Nachamkin, C. M. Szymanski, and M. J. Blaser (eds.), *Campylobacter*, 3rd ed., . American Society for Microbiology, Washington, DC.

16. **Gillespie SH, Ainscough S, Dickens A, Lewin J.** 1996. Phosphorylcholine-containing antigens in bacteria from the mouth and respiratory tract. *J. Med. Microbiol.* **44**:35-40.

17. **Guerry P, Doig P, Alm RA, Burr DH, Kinsella N, Trust TJ.** 1996. Identification and characterization of genes required for post-translational modification of *Campylobacter coli* VC167 flagellin. *Mol. Microbiol.* **19**:369-378.

18. **Guerry P, Ewing CP, Hickey TE, Prendergast MM, Moran AP.** 2000. Sialylation of lipooligosaccharide cores affects immunogenicity and serum resistance of *Campylobacter jejuni*. *Infect. Immun.* **68**:6656-6662.

19. **Guerry P, Ewing CP, Schirm M, Lorenzo M, Kelly J, Pattarini D, Majam G, Thibault P, Logan S.** 2006. Changes in flagellin glycosylation affect *Campylobacter* autoagglutination and virulence. *Mol. Microbiol.* **60**:299-311.

20. **Guerry P, Szymanski CM.** 2008. *Campylobacter* sugars sticking out. *Trends Microbiol.* **16**:428-435.

21. **Guerry P, Szymanski CM, Prendergast MM, Hickey TE, Ewing CP, Pattarini DL, Moran AP.** 2002. Phase variation of *Campylobacter jejuni* 81-176

lipooligosaccharide affects ganglioside mimicry and invasiveness in vitro. *Infect. Immun.* **70**:787-793.

22. **Gurgan T, Diker KS.** 1994. Abortion associated with *Campylobacter upsaliensis*. *J. Clin. Microbiol.* **32**:3093-3094.

23. **Ho TW, Hsieh ST, Nachamkin I, Willison HJ, Sheikh K, Kiehlbauch J, Flanigan K, McArthur JC, Cornblath DR, McKhann GM, Griffin JW.** 1997. Motor nerve terminal degeneration provides a potential mechanism for rapid recovery in acute motor axonal neuropathy after *Campylobacter* infection. *Neurology.* **48**:717-724.

24. **Karlyshev AV, Linton D, Gregson NA, Lastovica AJ, Wren BW.** 2000. Genetic and biochemical evidence of a *Campylobacter jejuni* capsular polysaccharide that accounts for Penner serotype specificity. *Mol. Microbiol.* **35**:529-541.

25. **Keo T, Collins J, Kunwar P, Blaser MJ, Iovine NM.** 2011. *Campylobacter* capsule and lipooligosaccharide confer resistance to serum and cationic antimicrobials. *Virulence.* **2**:30-40.

26. **Lastovica AJ, Le Roux E, Penner JL.** 1989. "*Campylobacter upsaliensis*" isolated from blood cultures of pediatric patients. *J. Clin. Microbiol.* **27**:657-659.

27. **Lysenko E, Richards JC, Cox AD, Stewart A, Martin A, Kapoor M, Weiser JN.** 2000. The position of phosphorylcholine on the lipopolysaccharide of *Haemophilus influenzae* affects binding and sensitivity to C-reactive protein-mediated killing. *Mol. Microbiol.* **35**:234-245.

28. **McNally DJ, Lamoureux MP, Karlyshev AV, Fiori LM, Li J, Thacker G, Coleman RA, Khieu NH, Wren BW, Brisson JR, Jarrell HC, Szymanski CM.** 2007. Commonality and biosynthesis of the *O*-methyl phosphoramidate capsule modification in *Campylobacter jejuni*. *J. Biol. Chem.* **282**:28566-28576.

29. **Mikolajek H, Kolstoe SE, Pye VE, Mangione P, Pepys, MB, Wood, SP.** 2011. Structural basis of ligand specificity in the human pentraxins, C-reactive protein and serum amyloid P component. *J. Mol. Recognit.* **24**:371-377.

30. **Moffitt MC, Frank MM.** 1994. Complement resistance in microbes. Springer Semin. Immunopathol. **15**:327-344.

31. **Mold C, Gewurz H, Du Clos TW.** 1999. Regulation of complement activation by C-reactive protein. *Immunopharmacology.* **42**:23-30.

32. **Noursadeghi M, Bickerstaff MC, Gallimore JR, Herbert J, Cohen J, Pepys MB.** 2000. Role of serum amyloid P component in bacterial infection: protection of the host or protection of the pathogen. *Proc. Natl. Acad. Sci. U. S. A.* **97**:14584-14589.
33. **Patton CM, Shaffer N, Edmonds P, Barrett TJ, Lambert MA, Baker C, Perlman DM, Brenner DJ.** 1989. Human disease associated with "*Campylobacter upsaliensis*" (catalase-negative or weakly positive *Campylobacter* species) in the United States. *J. Clin. Microbiol.* **27**:66-73.
34. **Sorensen MCH, van Alphen LB, Fodor C, Crowley SM, Christensen BB, Szymanski CM, Brondsted L.** 2012. Phase variable expression of capsular polysaccharide modifications allows *Campylobacter jejuni* to avoid bacteriophage infection in chickens. *Frontiers in Cellular and Infection Microbiology.* **2**:e.
35. **Stahl M, Friis LM, Nothaft H, Liu X, Li J, Szymanski CM, Stintzi A.** 2011. L-fucose utilization provides *Campylobacter jejuni* with a competitive advantage. *Proc. Natl. Acad. Sci. U. S. A.* **108**:7194-7199.
36. **Swords WE, Buscher BA, Ver Steeg Ii K, Preston A, Nichols WA, Weiser JN, Gibson BW, Apicella MA.** 2000. Non-typeable *Haemophilus influenzae* adhere to and invade human bronchial epithelial cells via an interaction of lipooligosaccharide with the PAF receptor. *Mol. Microbiol.* **37**:13-27.
37. **Szalai AJ, Agrawal A, Greenhough TJ, Volanakis JE.** 1997. C-reactive protein: structural biology, gene expression, and host defense function. *Immunol. Res.* **16**:127-136.
38. **Szalai AJ, Briles DE, Volanakis JE.** 1996. Role of complement in C-reactive-protein-mediated protection of mice from *Streptococcus pneumoniae*. *Infect. Immun.* **64**:4850-4853.
39. **Szymanski CM, Logan SM, Linton D, Wren BW.** 2003. *Campylobacter*: A tale of two protein glycosylation systems. *Trends Microbiol.* **11**:233-238.
40. **Thibault P, Logan SM, Kelly JF, Brisson JR, Ewing CP, Trust TJ, Guerry P.** 2001. Identification of the carbohydrate moieties and glycosylation motifs in *Campylobacter jejuni* flagellin. *J. Biol. Chem.* **276**:34862-34870.
41. **Thornton JA, Durick-Eder K, Tuomanen EI.** 2010. Pneumococcal pathogenesis: "innate invasion" yet organ-specific damage. *J. Mol. Med. (Berl).* **88**:103-107.

42. **Volanakis JE, Kaplan MH.** 1974. Interaction of C-reactive protein complexes with the complement system. II. Consumption of guinea pig complement by CRP complexes: requirement for human C1q. *J. Immunol.* **113**:9-17.
43. **Weiser JN, Love JM, Moxon ER.** 1989. The molecular mechanism of phase variation of *Haemophilus influenzae* lipopolysaccharide. *Cell.* **59**:657-665.
44. **Weiser JN, Pan N, McGowan KL, Musher D, Martin A, Richards J.** 1998. Phosphorylcholine on the lipopolysaccharide of *Haemophilus influenzae* contributes to persistence in the respiratory tract and sensitivity to serum killing mediated by C-reactive protein. *J. Exp. Med.* **187**:631-640.
45. **Weiser JN, Shchepetov M, Chong ST.** 1997. Decoration of lipopolysaccharide with phosphorylcholine: a phase-variable characteristic of *Haemophilus influenzae*. *Infect. Immun.* **65**:943-950.

CHAPTER 4

**Decoration of the capsular polysaccharides and lipooligosaccharides with
phosphorylated modifications alters host cell invasion of
*Campylobacter upsaliensis***

4.1 Introduction

Although *Campylobacters* have been studied extensively over the last 20 years, the molecular mechanisms involved in their interaction and subsequent invasion of host cells are still poorly understood. This situation results largely from the lack of adequate surrogate models to investigate *Campylobacter* pathogenesis. For example, *C. jejuni*, the best characterized species of the genera, lacks a routinely used animal pathogenesis model. This restricts researchers to utilize eukaryotic cell lines to form hypotheses about *Campylobacter* virulence factors.

Campylobacter upsaliensis is an emerging human pathogen most commonly associated with self-limiting gastroenteritis (4). Despite extensive epidemiological data implicating *C. upsaliensis* as an intestinal pathogen, only a few studies have examined possible mechanisms of its virulence. From these limited studies, it has been demonstrated that *C. upsaliensis* pathogenesis utilizes both microtubule- and microfilament-dependent mechanisms for the invasion of intestinal-derived epithelial cells, similar to *C. jejuni* invasion (2, 3, 29). *C. upsaliensis* also produces a cytolethal distending-like toxin, such as is produced in *C. jejuni*, *C. coli* and *C. lari*, which is characterized by a progressive distension and nuclear fragmentation culminating in cell death upon exposure for over five days (9, 30, 31, 33). This suggests *C. upsaliensis* may mirror aspects of *C. jejuni* pathogenesis, but currently there have been no studies to date examining specific virulence factors in *C. upsaliensis* host cell invasion.

The outer surface of *C. upsaliensis* is comprised of capsular polysaccharides (CPS) and lipooligosaccharides (LOS), which, as the outermost structures, play a key role in the bacterium's interactions with host cells. CPS and LOS are integral to host cell invasion and pathogenesis in animal models for *C. jejuni* (1, 5, 14, 15, 20, 36, 40). Manipulation of *C. jejuni* to create a truncated LOS or even loss of its sialylated outer core significantly impairs cell invasion (16, 19, 25). Similarly, loss of *C. jejuni* CPS results in reduced adherence and invasion of an INT-407 intestinal cell line (1).

Both of these complex carbohydrates are subject to variable non-carbohydrate modification. Approximately 70% of *C. jejuni* strains modify their CPS with phosphoramidate (MeOPN) and the MeOPN biosynthetic locus appears to be highly conserved among *Campylobacter species* (Figure 2.1) (21, 28). MeOPN-decorated CPS was highly prevalent among *C. jejuni* isolates recovered from enteritis and Guillain Barré syndrome patients, and a MeOPN biosynthetic mutant demonstrated attenuated virulence in a *Galleria mellonella* pathogenesis model (5, 28).

In conjunction with MeOPN, other phosphate containing modifications have been reported to decorate *Campylobacter* surface structures. In a genetic screen of over 100 European and South African *C. upsaliensis* isolates, there was a strong association between the presence of phosphocholine (PCho) biosynthetic genes and clinical symptoms (11). PCho is less prevalent among the *Campylobacters* (Figure 1, Chapter 2), but multiple respiratory pathogens such as

Streptococcus pneumoniae and *Haemophilus influenzae*, modify their glycolipids (teichoic acid, lipoteichoic acid or LOS) with PCho, and these modifications are important for host cell invasion (6, 42, 44).

Both *S. pneumoniae*, and *H. influenzae* utilize platelet activating factor receptor (PAFR) to cross the lung epithelium as well as the endothelium of the blood brain barrier (6, 42, 43). Bacterial surface display of PCho mimics PAFR's natural ligand, platelet activating factor (PAF), which is a proinflammatory chemokine and recognized by PAFR by its PCho group (44). Functional PAFR has been located on virtually every eukaryotic cell type, and can be detected on the host cell envelope as well as in perinuclear and intranuclear regions (22, 26, 27). *H. influenzae* adherence and invasion of a bronchial epithelial cell line was significantly decreased in strains that did not express PCho, and pre-treatment with a PAFR antagonist significantly inhibited *H. influenzae* invasion (43). PAFR knockout mice as well as mice treated with a PAFR antagonist both presented reduced dissemination of infection, less pulmonary inflammation as well as delayed and reduced mortality when infected with *S. pneumoniae* (39).

The aim of this work was to characterize the roles MeOPN and PCho play in the interaction of *C. upsaliensis* with the intestinal epithelium. Removal of these moieties significantly impairs host cell adherence and invasion, which appears to be mediated through the platelet activating factor receptor.

4.2 Material and Methods

4.2.1 Bacterial strains and growth conditions

The bacterial strains used in this study are listed in Table 4.1. The *C. upsaliensis* strain RM3195 (ATCC BAA-1059, Manassas, VA, USA) was originally obtained from the feces of a 4-year-old Guillain-Barré syndrome patient and its genome later sequenced by Fouts and colleagues (11). The construction and phenotypic testing of the MeOPN mutant, *Cup_0802::cat*, and the PCho mutant, *licC::cat*, are described in Chapter 2.

Table 4.1 Strains used in this study.

Strain	Description	Reference or source
RM3195 wt	Human clinical isolate	(11)
RM3195 <i>licC::cat</i>	RM3195; <i>licC</i> mutant, Cm ^R	Chapter 2
RM3195 <i>Cup_0802::cat</i>	RM3195; <i>CUP_0802</i> mutant, Cm ^R	Chapter 2

All *C. upsaliensis* strains were routinely grown on Blood Agar Base No. 2 (Oxoid, Basingstoke, Hampshire, UK) which was supplemented with 7 % Horse Blood (Quadfive, Ryegate, MT) and 1 % Yeast Extract (BD/Bacto, Franklin Lakes, NJ, USA) and grown at 37 °C under microaerobic conditions (85 % N₂, 10 % CO₂ and 5 % O₂). Chloramphenicol (Cm) (Sigma-Aldrich, Oakville, ON) was added to the agar plates at a final concentration of 20 µg ml⁻¹.

For biphasic growth, upright 25 cm² tissue culture flasks were filled with 5 ml of Brain Heart Infusion broth (BD/Difco) supplemented with 1% Yeast Extract (BHIY) plus 1.5 % agar and 5 ml of BHIY broth was added on top of the

solidified agar. *C. upsaliensis* from 16 h plates was used to inoculate upright flasks, which were incubated at 37 °C under microaerobic conditions with shaking at 140 rpm. Antibiotics were not added to the biphasic media. RM3195 did not grow in biphasic flasks without shaking.

Caco-2 (ATCC HTB-27; American Type Culture Collection) and HT-29 (ATCC CCL-218; American Type Culture Collection) human intestinal epithelial cells were cultured as described by the American Type Culture Collection in Eagle's Minimum Essential Medium (Sigma-Aldrich) supplemented with 15% fetal bovine serum (Sigma-Aldrich) or McCoy's Medium (Life Technologies, Burlington, ON) supplemented with 10% fetal bovine serum, respectively. Media on seeded cells was replaced every second day.

4.2.2 *Adherence and invasion assay*

The invasion assays were performed as described by Hu and Kopecko (17). One ml of Caco-2 cells were added to a 24-well plate at a concentration of 5×10^4 cells per well while HT-29 were seeded at a concentration of 1×10^5 cells per well and both were incubated for 48 h. To initialize bacterial infection, tissue cultures were pre-incubated in 250 μ l of appropriate tissue culture media supplemented with 1 % FBS for 30 min. Following this incubation, an overnight biphasic culture of bacteria were pelleted (4000 x g), resuspended in appropriate tissue culture media, pelleted and washed two times further in tissue culture media. Bacteria were then diluted in pre-warmed tissue culture media and 50 μ l added to eukaryotic cell-containing wells to a final OD₅₅₀ of 0.5 (1×10^8 CFU).

The multiplicity of infection (MOI, cells:bacteria) used was approximately 1:500. Infected monolayers were not centrifuged but incubated for 5 h at 37 °C in 5 % CO₂ - 95 % air. Following the invasion period, the monolayers were washed three times with PBS, then the host cells were lysed using 0.1 % Triton X-100 in PBS for 15 min (or until cells appeared lysed and nonadherent under phase contrast microscopy) at room temperature on an orbital shaker. After serial dilution in PBS, adherent cells as well as released intracellular bacteria were enumerated by colony counting on Blood agar after 48 h of incubation. For invasion data, after the infection period and PBS washes, monolayers were further incubated for 1 h in fresh tissue culture medium supplemented with 500 µg ml⁻¹ gentamicin (Sigma-Aldrich) to kill only surface adherent bacteria. After the gentamicin-killing period, the infected monolayers were washed, treated with Triton X-100, plated and CFUs counted as described above. 'Invasion CFU' was subtracted from 'Adherent and Invasive CFU' to give adherence data. Values are the average CFU of three independent experiments repeated in triplicate, with standard deviations. Control experiments confirmed that 500 µg ml⁻¹ gentamicin killed all extracellular bacteria within 1 h.

For the PAFR antagonist experiments, 1, 10 or 100 nM of 1-O-hexadecyl-2-acetyl-sn-glycerol-3-phospho-(N,N,N-trimethyl)-hexanolamine (Santa Cruz Biotechnology Inc., Santa Cruz, CA, USA) or 1-(N,N-Dimethylcarbamoyl)-4-ethynyl-3-(3-fluoro-4-((1H-2-methylimidazo[4,5-c]pyridin-1-yl)methyl)benzoyl)-indole, HCl (EMD Millipore, Darmstadt, DE) were added to seeded cells in the

pre-infection media and incubated for 30 min before infection. The invasion assay was conducted as described above. Values are the average CFU of three independent experiments repeated in triplicate, with standard deviations.

4.2.3 *Scanning electron microscopy and transmission electron microscopy*

Caco-2 monolayers were seeded onto sterile coverslips, grown for 1 week and infected as described above with modification. After 1 h infection (this time point was altered from adherence and invasion assays to better visualize the initial interaction bacterial interactions and early stages of invasion), cells were washed with PBS and fixed overnight in 2 % glutaraldehyde in PBS (Sigma-Aldrich). Cells were then quickly washed in PBS followed by 20 min dehydrations with increasing ethanol concentrations (50 %, 70 %, 90 %, then two 100 % incubations).

For transmission electron microscopy (TEM), dehydrated cells were infiltrated by ethanol 1:1 Spurr's resin overnight (Sigma-Aldrich). Then, the samples were embedded in 100 % Spurr's resin and cured at 70 °C overnight with the plate lid removed. After polymerization, hardened samples were “popped-off” coverslips by briefly submerging the samples in liquid nitrogen. Samples were then sectioned by an Ultracut E ultramicrotome (Reichert-Jung, Depew, NY, USA), collected on copper mesh grids and observed in a Philips/FEI Morgagni transmission electron microscope (Field Emission Instruments) operating at 200 kV under the supervision of Arlene Oatway. For nanogold experiments, sections were collected on nickel grids and placed face down on a droplet of 5 % bovine

serum albumin (BSA, Bioshop) in PBS on a TEM staining plate. After extensive washing, grids were transferred to a double primary antibody solution containing TEPC-15 mouse IgA antibody (Sigma-Aldrich) diluted 1:100 and PAFR rabbit polyclonal IgG antibody sc-20732 (Santa Cruz Biotechnology Inc.) diluted 1:100 in 1 % BSA (Bioshop) in PBS for 1 h. Samples were washed then transferred to a double secondary antibody solution containing anti-mouse IgG 10 nm nanogold (Sigma-Aldrich) and anti-rabbit IgG 5 nm nanogold (Nanoprobes, Yaphank, NY, US) for 1 h. Grids underwent ten additional wash steps then were visualized as described above.

For scanning electron microscopy (SEM), dehydrated cells were incubated for 20 min in increasing hexamethyldisilazane (HMDS, Sigma-Aldrich) concentrations (75 % ethanol: 25 % HMDS, 50 % ethanol: 50 % HMDS, 25 % ethanol: 75 % HMDS, then two 100 % HMDS), then left to air dry overnight. The samples were mounted onto SEM stubs and sputter coated with a thin layer of gold. The coated samples were observed under a Philips/FEI XL30 scanning electron microscope (Field Emission Instruments, Hillsboro, OR, USA) using an accelerating voltage of 30 kV under the supervision of Arlene Oatway.

4.2.4 *Immunofluorescence microscopy*

C. upsaliensis was fluorescently labeled with $10 \mu\text{g ml}^{-1}$ tetramethylrhodamine (TAMRA, Life Technologies) in PBS at 37 °C for 30 min prior to infection. Bacteria were then washed in PBS and used to infect Caco-2 cell monolayers as described in section 4.2.2; however, Caco-2 monolayers were

seeded on sterile coverslips. After a 5 h infection, cells were washed three times in PBS and fixed in 4 % paraformaldehyde (PFA) for 30 min. The fixed cells were washed three times in PBS and permeabilized by incubation in 0.1 % Triton X-100 in PBS for 15 min. Cover slips were incubated in PAFR rabbit polyclonal IgG antibody sc-20732 (Santa Cruz Biotechnology Inc.) diluted 1:500 in 1 % BSA in PBS for 1 h. The coverslips were then washed three times in PBS and incubated in Alexa Fluor 488 goat anti-rabbit IgG (H+L) diluted 1:1000 in 1 % BSA in PBS for 1 h. After three washes in PBS, cells were incubated in 300 ng ml⁻¹ DAPI for 30 min, washed, then mounted onto glass slides using Fluoromount-G (Sigma-Aldrich). Images were acquired on a Leica DMRXA compound light microscope (Leica Microsystems Inc., Concord ON) fitted with a Nikon digital camera (Nikon Instruments Inc., Melville, NY, USA).

4.2.5 *siRNA knockdown*

An ON-TARGET plus SMARTpool (Dharmacon, Lafayette, CO, USA) containing four different siRNA sequences designed to target human PAFR and an ON-TARGETplus non-targeting pool (Dharmacon) were resuspended separately in DNase/RNase-free water (Sigma-Aldrich) to a final concentration of 20 μM. DharmaFECT 1 (Dharmacon) or Lipofectamine RNAiMAX (Life Technologies) were used as the transfection reagents. Caco-2 cells were seeded at a density of 5 x 10⁴ cells per well while HT-29 were seeded at a concentration of 4 x 10⁵ cells per well in 24-well plates at 37 °C overnight. On the day of transfection, pooled siRNA was diluted to a final concentration of 5, 10 or 100

nM in 100 μ l culture media without serum. Five μ l of transfection reagent was added and samples were incubated for 5-10 minutes to allow formation of transfection complexes. The complexes were added drop-wise into the wells and incubated for 24 h. The transfection medium was replaced with fresh media and the cells were incubated for a total of 48, 72 or 96 h. Western blotting was used to measure protein levels after transfection.

Reverse transfection was also carried out. Instead of seeding the cells the night before transfection, cells were first trypsinized and normalized to the concentrations outlined above. Transfection complexes were added to the 24-well plate first, followed by cells resuspended in fresh media without serum. All other details proceeded as described above.

4.2.6 SDS-PAGE experiments and immunoblotting

Whole cell lysates were prepared by resuspending adherent Caco-2 cells in 40 mM Tris-HCl, pH = 7.4 supplemented with cOmplete, EDTA-free Protease inhibitor cocktail (Roche, Indianapolis, IN, USA) and phosphatase inhibitors, 50 mM NaF and 5 mM sodium orthovanadate (Sigma-Aldrich), for samples to be run on Phos-tag SDS-PAGE. Laemmli protein loading buffer was added and then samples were incubated overnight at room temperature. Whole cell lysates were separated on a 12.5 % SDS-PAGE for siRNA experiments or a 5 % Phos-tag SDS-PAGE for the PAFR phosphorylation experiments, prepared according to the manufacturer's instructions. Before Western transfer, the Phos-tag gel was washed in 1 mM EDTA for 10 min to remove manganese ions.

Proteins from both gels were transferred onto polyvinylidene difluoride (PVDF) membranes (Millipore, Billerica, MA, USA) and blocked overnight with 5 % BSA in phosphate-buffered saline-0.1 % Tween (PBST). Immunoblotting of the membrane was carried using 1:5,000 dilution of the polyclonal PAFR rabbit IgG antibody sc-20732 (Santa Cruz Biotechnology Inc.) in PBST with 1 % BSA for 1 h followed by another 1 h incubation after PBST washes in 1:5,000 dilution of rabbit anti-mouse IgG antibody conjugated to alkaline phosphatase (Santa Cruz Biotechnology Inc.). The blot was developed with nitroblue tetrazolium-5-bromo-4-chloro-3-indolylphosphate solution (NBT-BCIP) (Roche).

4.3 Results

4.3.1 C. upsaliensis adheres to and invades intestinal epithelial cells

SEM and TEM were used to examine the interactions between *C. upsaliensis* with its host cells. Caco-2 cells were grown for one week prior to infection, to allow for cellular differentiation. These monolayers were confluent and decorated by dense apical microvilli that extended into the media above, correctly mimicking the host's intestinal epithelium (Figure 4.1A and 4.1C).

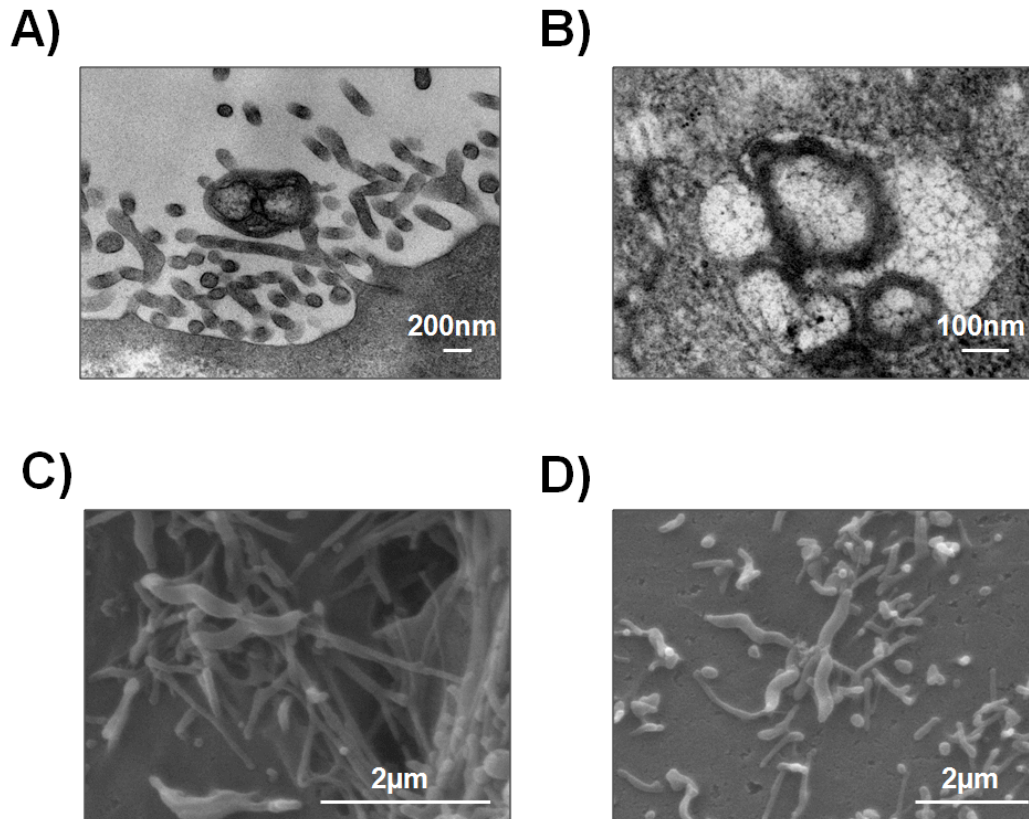

Figure 4.1 TEM and SEM of *C. upsaliensis* of adherence to and invasion of Caco-2 cells. **A)** TEM showing a longitudinal section of a single *C. upsaliensis* RM3195 wt and its intimate association with surrounding microvilli. **B)** TEM showing *C. upsaliensis* RM3195 wt internalization in a membrane-bound structure. This endosome appears to contain 4 bacteria. **C)** SEM showing *C. upsaliensis* RM3195 wt interaction with microvilli through its flagella. **D)** SEM showing *C. upsaliensis* RM3195 wt interaction with microvilli through its flagella. The surrounding area appears to be devoid of microvilli and the microvilli in contact with *C. upsaliensis* have become shortened.

The monolayers were infected without centrifugation to prevent artificial adherence by forcing *C. upsaliensis* to interact with the host cells. Consistent with observations in *C. jejuni*, the microvilli of Caco-2 cells interact with the longitudinal surface of RM3195 wt (Figure 4.1A, 4.1C and 4.1D) (18). RM3195 wt appears to anchor itself through connecting its flagella to the cell surface or on a microvillus (Figure 4.1C and 4.1D). In Figure 1C, it appears that *C. upsaliensis* may position its spiral cell shape to twist in among the microvilli, allowing increased surface area of the bacterium to come in contact with the host's cell surface. Interestingly, it was frequently observed that the microvilli in the immediate environment surrounding RM3195 wt had been shortened or removed completely (Figure 4.1D).

After 1 h of infection, RM3195 wt was present either on cell surfaces or inside Caco-2 cells. It appears RM3195 wt is internalized via an endosome (Figure 1B), which is consistent with a report from Mooney and colleagues describing *C. upsaliensis* CU1887 infection, as well as multiple reports from *C. jejuni* (18, 29, 47). All endosomes observed contained multiple RM3195 wt cells, ranging from two to five bacteria per Caco-2 cell. However, due to the spiral nature of *C. upsaliensis* it is difficult to estimate how the cell is orientated in the TEM image, which may have resulted in an overestimate of this endosomal population. Adherence and invasion was not evenly distributed among the monolayers observed. Only a few cells contained adherent and invasive RM3195

wt, indicating these cells may present specialized receptors or features that *C. upsaliensis* manipulates for host cell invasion.

We did not observe RM3195 wt within tight junctions. This suggests that *C. upsaliensis* does not utilize a transcellular host invasion mechanism as is hypothesized in *C. jejuni* (45).

4.3.2 Removal of MeOPN and PCho decreases adherence and invasion of intestinal epithelial cells

A gentamicin adherence and infection assay was performed to examine the role of MeOPN or PCho in host cell invasion. Caco-2 monolayers were infected with RM3195 wt and the two biosynthetic mutants for 5 h. Both *Cup_0802::cat* and *licC::cat* demonstrated decreased adherence (Figure 4.2) and invasion (Figure 4.3) compared to RM3195 wt. A similar reduction was also observed in another colorectal adenocarcinoma cell line, HT-29 (data not shown). It should be noted that RM3195 wt is not as invasive as *C. jejuni* 81-176. Compared to values in the literature, RM3195 wt invades approximately 20-fold less than 81-176, but its invasion levels are comparable to *C. upsaliensis* ATCC43954 as observed by Mooney *et. al.* (18, 29, 48). The reduction in invasion due to loss of PCho or MeOPN, could be because these phosphorylated moieties are used as adhesions to enter the host cell or they aid in intracellular host survival.

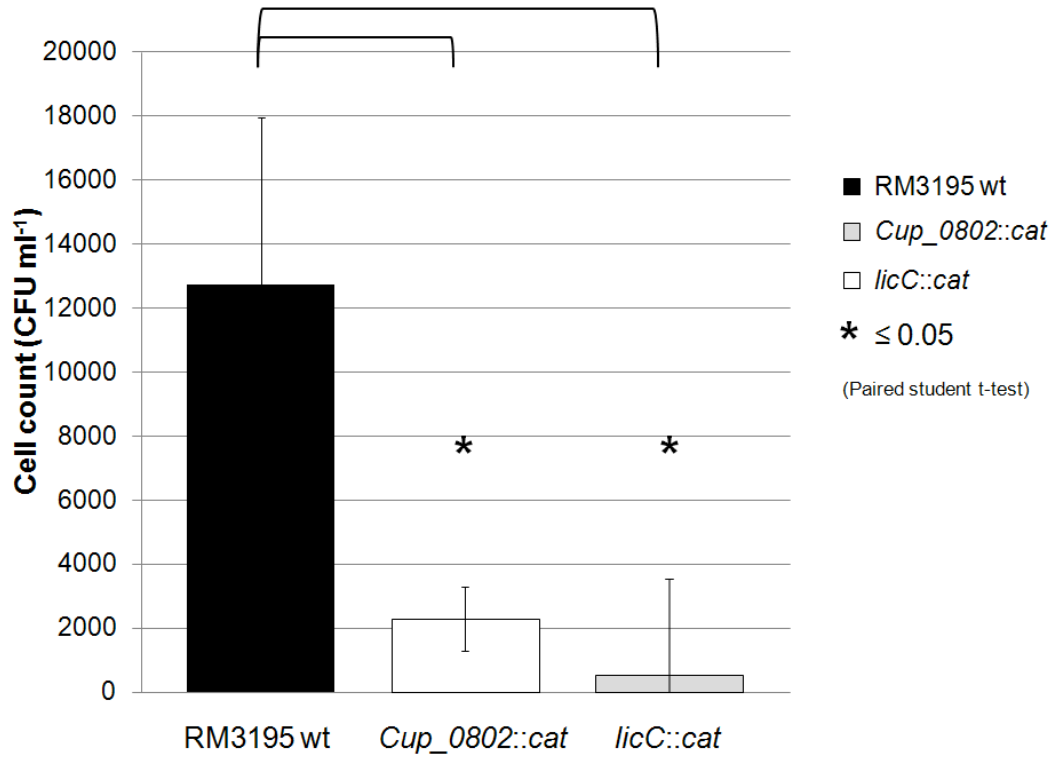

Figure 4.2 Removal of MeOPN or PCho decreases *C. upsaliensis* RM3195 ability to adhere to Caco-2 intestinal epithelial cells after a 5 h infection period. All CFU ml⁻¹ are means of three separate trials done in triplicate \pm standard deviation.

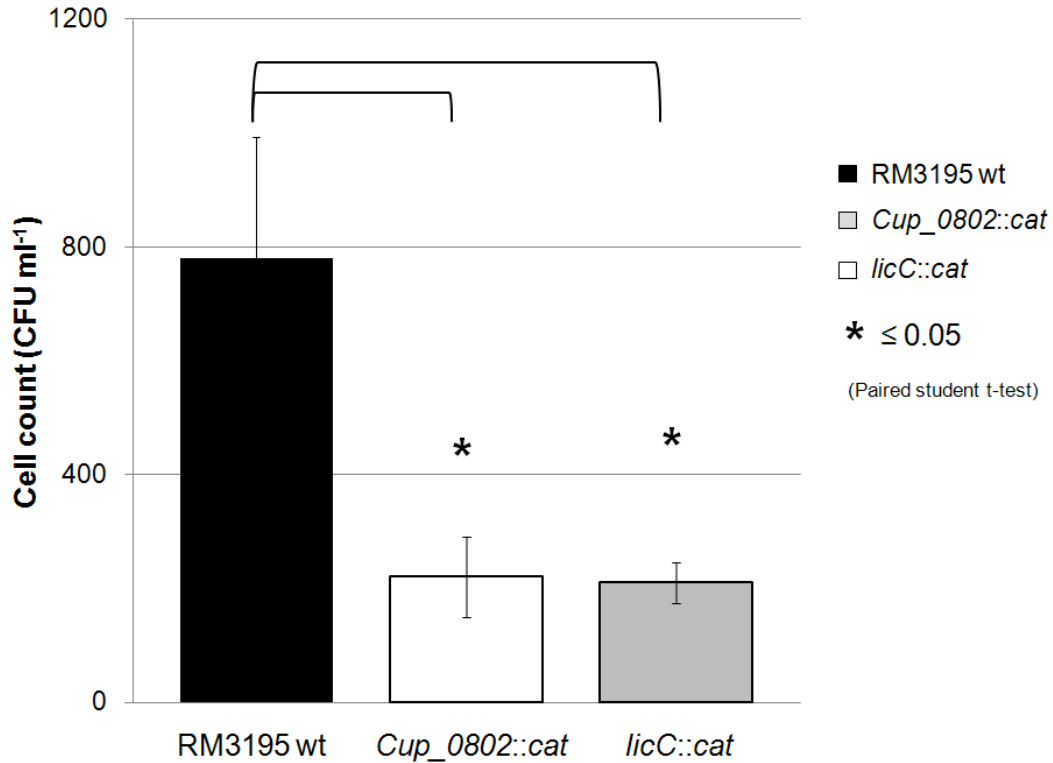

Figure 4.3 Removal of MeOPN or PCho decreases *C. upsaliensis* RM3195 ability to invade Caco-2 intestinal epithelial cells after a 5 h infection period. All CFU ml⁻¹ are means of three separate trials done in triplicate \pm standard deviation.

4.3.3 *C. upsaliensis* co-localizes with platelet activating factor receptor

PAFR is located on a variety of endothelial and epithelial cells types and has been shown to mediate PCho-dependent invasion of *H. influenzae* and *S. pneumoniae* (6, 42). In order to address the decrease in adherence and invasion observed in both MeOPN and PCho biosynthetic mutants, fluorescent microscopy and nanogold TEM were utilized to examine the possible interaction between *C. upsaliensis* and PAFR.

Preliminary results demonstrate that RM3195 wt co-localizes with PAFR (Figure 4.4D) but no co-localization was observed in cells infected with *Cup_0802::cat* and *licC::cat* (Figure 4.4H and 4.4L, respectively). It also appears that this co-localization may occur between RM3195 wt PCho-decorated LOS and PAFR (Figure 4.5). The TEM image in Figure 4.5 shows a clustering of PAFR along a Caco-2 microvillus and one PAFR (white arrow) which is within close proximity to a labeled PCho LOS (black arrow) on RM3195 wt. However, both of these results need to be repeated to yield more convincing images.

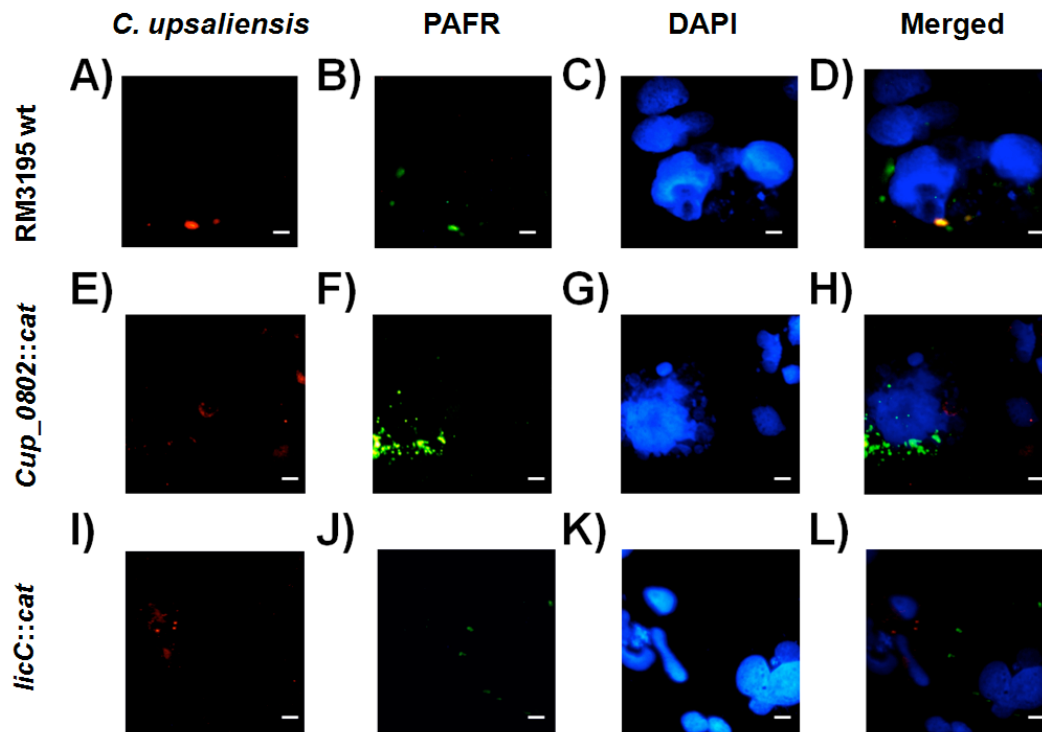

Figure 4.4 Representative immunofluorescence microscopy images of *C. upsaliensis*-infected Caco-2 cells demonstrating RM3195 wt co-localization with PAFR. Caco-2 cells infected with TAMRA-labeled *C. upsaliensis* RM3195 for 5 h then fixed, permeabilized, and labeled with fluorescent antibodies against PAFR. Fluorescence microscopic images of TAMRA *C. upsaliensis* at 546nm with **A)** RM3195 wt, **E)** *Cup_0802::cat*, and **I)** *licC::cat*. Fluorescence microscopic images of PAFR with 488nm Alexa Fluor secondary **B)** RM3195 wt, **F)** *Cup_0802::cat*, and **J)** *licC::cat*. Fluorescence microscopic images of DAPI-stained nuclei **C)** RM3195 wt, **G)** *Cup_0802::cat*, and **K)** *licC::cat*. TAMRA, PAFR and DAPI images were merged **D)** RM3195 wt, **H)** *Cup_0802::cat*, and **L)** *licC::cat*. Bar markers represent 10 μ m.

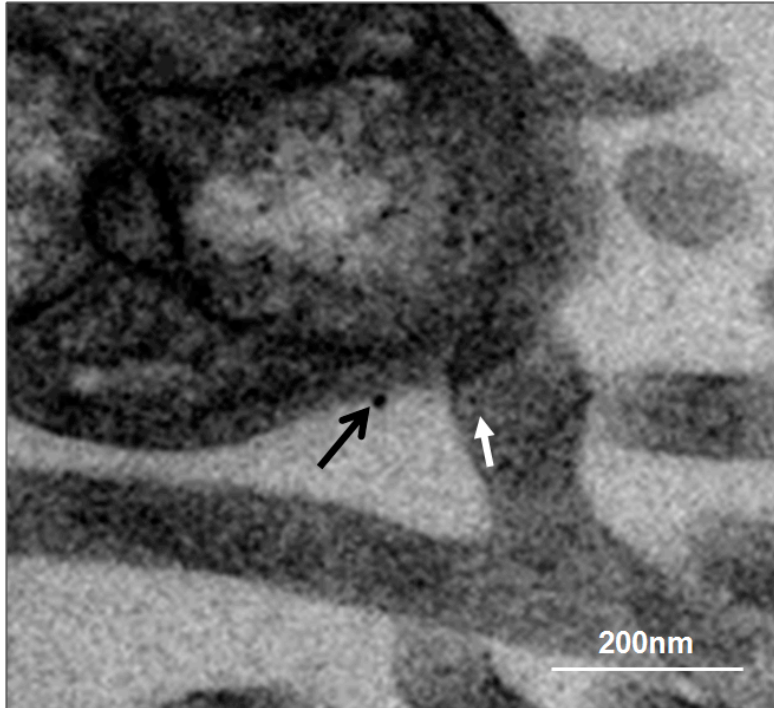

Figure 4.5 *C. upsaliensis* PCho-modified LOS may co-localize with Caco-2 PAFR. TEM of *C. upsaliensis* adherence to Caco-2 cells, stained with immunogold against PAFR (5 nm, white arrow) and PCho (10 nm, black arrow).

4.3.4 Addition of a platelet activating factor receptor antagonist decreases *C. upsaliensis* invasion

The possible role of PAFR as an RM3195 invasion receptor was tested by the pre-incubation of Caco-2 cells with a specific PAFR antagonist (1-O-hexadecyl-2-acetyl-sn-glycerol-3-phospho-(N,N,N-trimethyl)-hexanolamine) 30 min before RM3195 wt infection. Using as little as 10 nM of this antagonist, the invasion of RM3195 wt was reduced to the same levels as *Cup_0802::cat* and *licC::cat* (Figure 4.6). This was further tested through use of another PAFR

antagonist (1-(N,N-Dimethylcarbamoyl)-4-ethynyl-3-(3-fluoro-4-((1H-2-methylimidazo[4,5-c]pyridin-1-yl)methyl)benzoyl)-indole, HCl), which reduced RM3195 wt invasion to levels achieved by the other antagonist (data not shown). This suggested RM3195 could be utilizing the PAFR via its PCho or MeOPN moieties in order to invade intestinal epithelial cells.

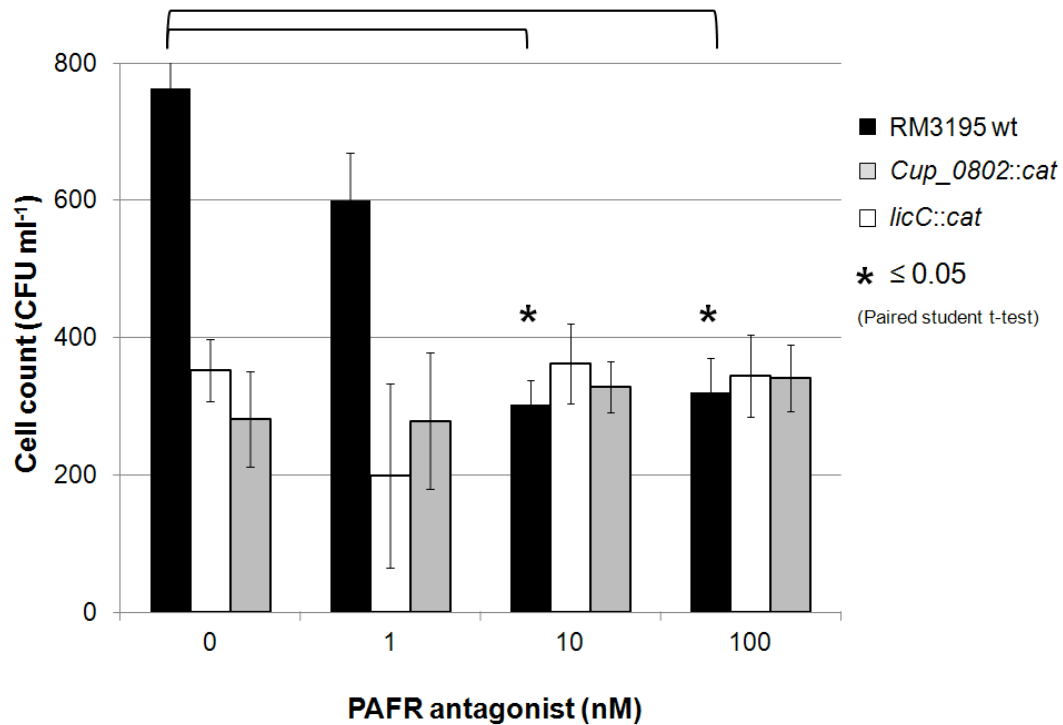

Figure 4.6 Addition of a PAFR antagonist decreases *C. upsaliensis* ability to invade Caco-2 intestinal epithelial cells but does not alter invasion of the *Cup_0802::cat* or *licC::cat* mutants. Invasion of Caco-2 cells, preincubated for 30 mins with a PAFR antagonist before infection with RM3195 wt, *Cup_0802::cat* and *licC::cat* for 5 h. All CFU ml⁻¹ are means of two separate trials done in triplicate \pm standard deviation.

4.3.5 Infection with *C. upsaliensis* does not activate platelet activating factor receptor

C. upsaliensis-mediated activation of PAFR was tested through use of a Phos-tag gel. Phos-tag binds anionic substituents, such as phosphate groups, and adds additional charge. This facilitates the detection of phosphorylated proteins by band shifts when separated by SDS-PAGE. PAFR auto-phosphorylates when platelet activating factor binds, initiating a signal transduction pathway (38)(44). Whole cell lysates from a short infection period of Caco-2 by RM3195 wt were separated on a Phos-tag SDS-PAGE and blotted for PAFR. There was no detectable shifts in the PAFR bands over the course of the RM3195 wt infection (Figure 4.8).

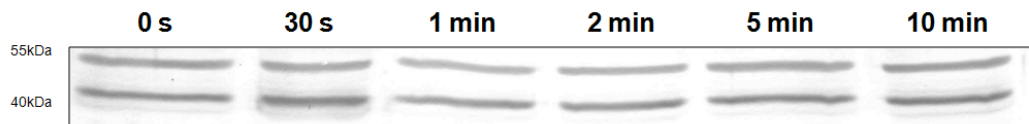

Figure 4.8 *C. upsaliensis* does not activate PAFR to undergo auto-phosphorylation within 10 min after infection. Western blot of PAFR produced from Mn^{2+} SDS-PAGE with $\sim 25 \mu g$ of protein per a lane of whole cell lysates from Caco-2 cells infected with *C. upsaliensis* RM3195 wt from 0 to 10 min. A shift in PAFR band signifies an increased phosphorylation state.

4.4 Discussion

In this study, we confirm that *C. upsaliensis* invades intestinal epithelial cells and its association and subsequent invasion of host cells closely resembles the microscopic characterization of *C. jejuni* invasion by Hu and colleagues (18). SEM experiments revealed *C. upsaliensis* anchors itself to the surface of Caco-2 cells through an intimate association of both of its polar flagella to the microvilli (Figure 1C and 1D). This brings the elongated surface of *C. upsaliensis* in closer proximity to the host cell surface. Flagella have been consistently associated with *Campylobacter* virulence (13, 34, 46). They are required for *C. jejuni* motility, colonization and in some strains, secretion of effector proteins (the Cia proteins) (23). Mutation to *flaA*, the major protein component of the *C. jejuni* flagella, significantly decreases bacterial invasion of INT-407 cells (46). However, invasion levels were partially restored by gentle centrifugation of the *flaA* mutants onto the surface of the cell (46). This implicates flagella as an integral *Campylobacter* adherence ligand. Binding of flagella to the microvilli brings the host cell and bacterium in closer contact to facilitate invasion-specific bacterial ligands for *Campylobacter* internalization. Interestingly, it appeared that the crevice in the spiral of *C. upsaliensis* facilitated this interaction by weaving through microvilli that extend from the cell surface. We did not observe any bacteria binding perpendicular to the cell, which is consistent with observations by Hu *et. al.* that reported polar binding was extremely rare in *C. jejuni* infection (18). Hu and colleagues also observed the surface of *C. jejuni* was not smooth, as

C. upsaliensis appears in Figures 1C and 1D, but contorted into “brain-like” twists they hypothesized would house different ligands for bacterium-host interactions (18). The appearance of smooth *C. upsaliensis* cells in Figure 1C and 1D could be due to the use of a lower resolution transmission electron microscope compared to the instrument used by Hu and colleagues.

C. upsaliensis is internalized into Caco-2 cells in an endosome (Figure 1B). This is consistent with previous reports on *C. upsaliensis* as well as *C. jejuni* (18, 24, 29, 35). *C. jejuni* is hypothesized to travel through the epithelial cell from the apical surface and is ejected in the sub-epithelium, in order to facilitate bacterial dissemination. *C. jejuni* is able to survive within intestinal epithelial cells by preventing its delivery to the lysosome (47). Mooney and colleagues observed a septated *C. upsaliensis* inside an endosome, suggesting *C. upsaliensis* may replicate within the endosomal compartment (29). Although we did not observe any evidence of this phenomenon, *C. upsaliensis* may be able to survive and replicate intracellularly.

C. upsaliensis adherence and invasion was not consistent across the Caco-2 monolayer. Certain cells appear hypersensitive to *C. upsaliensis* association, which may indicate these cells present specialized receptors or ligands that *C. upsaliensis* manipulates for host cell interaction. Hu and colleagues reported a similar observation for differentiated Caco-2 cells (18). Approximately 2% of differentiated Caco-2 cells contained seven to 20 internalized *C. jejuni* per a cell, compared to the even distribution of infected *C. jejuni* in undifferentiated Caco-2

and INT-407 cells. These highly infected cells may represent M-like cells, although this is difficult to confirm due to the lack of tools to identify M-cells. Hu *et. al.* also observed shortened and fewer microvilli either surrounding or in direct contact with adherent *C. jejuni* which is consistent with our observations for *C. upsaliensis* (Figure 1D) (18). They hypothesized this represents the localized collapse of the terminal F-actin web, causing shortening and coalescence of the microvilli. *C. jejuni* invasion of host cells is enhanced in the presence of cytochalasin D, an inhibitor of actin polymerization, possibly by the removal of this terminal actin web (17). However, *C. upsaliensis* invasion is decreased in the presence of cytochalasins B and D (29). This indicates the disappearance and shortening of the microvilli in the presence of *C. upsaliensis* is occurring by a separate mechanism and does not involve the manipulation of the microvilli actin bundle.

PCho and MeOPN are involved in *C. upsaliensis* adherence and invasion (Figures 2 and 3). This is the first report to our knowledge of the identification of a *C. upsaliensis* virulence factor. LOS has been consistently identified as a *Campylobacter* virulence factor and truncation of *C. jejuni* LOS significantly impairs cell invasion (15, 16, 19, 25, 32). CPS mutants in *C. jejuni* also exhibit decreased cell invasion and reduced virulence in a ferret diarrhoeal disease model (1). Interestingly, the MeOPN mutant in *C. upsaliensis* demonstrates the opposite phenotype of a *C. jejuni* mutant in cell invasion. Preliminary data generated in the Szymanski and Brøndsted labs indicates a *C. jejuni* MeOPN mutant increases cell

invasion (van Alpen, L.B. and Sørensen, M.C.H., personal communication). This discrepancy between the two species could be a species or even a strain dependent effect, similar to the differences in serum survival observed between different *C. upsaliensis* isolates as described in Chapter 3. MeOPN-dependent cell invasion could rely more on the composition of the CPS and the context in which MeOPN is presented. The RM3195 wt genome has undergone significant rearrangements especially to its LOS and CPS loci compared to *C. jejuni* (11). The LOS biosynthetic locus has incorporated several gene insertions of *C. jejuni* 11168 homologs that are unrelated to LOS biosynthesis. Also, the CPS biosynthesis locus has been broken into three clusters and incorporates many ORFs that are unique to RM3195 wt, such as two putative GDP-fucose synthetases. This indicates the sugar composition of RM3195 wt CPS and LOS is most likely different than *C. jejuni* 11168 and this may alter how the host cell interacts and detects MeOPN and PCho.

The decrease in Caco-2 cell invasion observed for the PCho mutant is consistent with reports from both *H. influenzae* and *S. pneumoniae* (6, 42). *H. influenzae* 2019 demonstrated increased adherence and invasion of a bronchial epithelial cell line, 16HBE14, compared to a PCho mutant and a truncated LOS mutant (42). *S. pneumoniae* PCho mutants were avirulent in a murine sepsis model and facilitated their own immunological clearance through activation of splenic dendritic cells (12). This PCho-mediated invasion is modulated by PAFR. PCho-decorated LOS and teichoic acids present the PCho group within a specific

structural context that mimics the proinflammatory chemokine PAF (42). This facilitates PAFR engagement and subsequent invasion by the bacterium. Incubation of Caco-2 cells with a PAFR antagonist prior to *C. upsaliensis* infection decreased RM3195 wt invasion but did not affect *Cup_0802::cat* or *licC::cat* cell invasion (Figure 6). *C. upsaliensis* also co-localized with PAFR in a fluorescent microscopy experiment (Figure 4). These findings suggest *C. upsaliensis* may be utilizing the PAFR via the PCho and/or MeOPN moieties. Infection with *S. pneumoniae* of mice lacking PAFR or mice treated with PAFR antagonists, were resistant to meningitis as well as the progression of pneumonia to sepsis (37, 39). PCho-presenting *H. influenzae* strains co-localized with PAFR and pre-treatment with a PAFR antagonist decreased bacterial cell invasion (42).

Although PAFR is a G protein coupled receptor, it can initiate signal transduction pathways through both G protein coupled and uncoupled cellular signaling (37, 41). PCho-modified pneumococcal cell wall can trigger a diverse array of signal responses in a PAFR-mediated organ-dependent manner (10). Pneumococcal cell wall can enter the cytoplasm and nucleus of endothelial cells and neurons via G-protein independent PAFR and β -arrestin 1 without inducing a proinflammatory Nod 1/2 NF- κ B response. However its uptake into cardiomyocytes results in activation of PLC γ and a subsequent loss of contractility (8). This was also examined in a Langendorff *ex vivo* heart model, in which continuous infusion of pneumococcal cell wall was associated with a significant decrease in left ventricular developed-pressure but no difference was

observed in ethanolamine cell wall controls (10). Signal transduction of PCho-induced PAFR in epithelial cells is G-coupled dependent and in *H. influenzae* infection results in increased cytosolic Ca^{2+} and inositol phosphate levels (10, 43). *C. upsaliensis* appears to bind and invade intestinal epithelial cells in a PAFR-mediated mechanism. However, the direct activation of PAFR by *C. upsaliensis*, as measured by PAFR auto-phosphorylation, did not occur (Figure 4.8). This could be due to *C. upsaliensis* inducing a signal transduction event different than those characterized from the lung epithelia, such as a G protein independent signaling cascade. However, it is more likely that 10 min is insufficient for *C. upsaliensis* to move to the cell surface, bind and activate PAFR in a manner that would be readily detectable with the methods used. The cell adherence and invasion experiments conducted in this study took place over 5 h, and the SEM and TEM images were taken after 1 h. Bacterial adherence and induced signaling should occur faster than 1 h, but a maximum time of 10 min may be too short for *C. upsaliensis* to reach the Caco-2 cell surface.

Phosphorylated modifications of *C. upsaliensis* surface structures are important for its virulence. Removal of MeOPN or PCho reduced the ability of *C. upsaliensis* to invade host intestinal epithelial cells. These phosphorylated moieties appear to be utilizing PAFR as an invasion receptor, as demonstrated by the reduction of RM3195 wt invasion in the presence of a PAFR antagonist. However, this could not be confirmed due to the inability to knockdown Caco-2 or HT-29 PAFR expression by siRNA. Also, PAFR is not activated during a *C.*

upsaliensis infection under the conditions tested. MeOPN and PCho are the first characterized virulence factors in *C. upsaliensis* but further work is required to elucidate the mechanism by which they impact *C. upsaliensis* host cell invasion.

4.5 Acknowledgements

The authors would like to thank Dr. Edan Foley and Anja Schindler for siRNA supplies and assistance.

4.6 Literature cited

1. **Bacon DJ, Szymanski CM, Burr DH, Silver RP, Alm RA, Guerry P.** 2001. A phase-variable capsule is involved in virulence of *Campylobacter jejuni* 81-176. *Mol. Microbiol.* **40**:769-777.
2. **Biswas D, Itoh K, Sasakawa C.** 2000. Uptake pathways of clinical and healthy animal isolates of *Campylobacter jejuni* into INT-407 cells. *FEMS Immunol. Med. Microbiol.* **29**:203-211.
3. **Biswas D, Itoh K, Sasakawa C.** 2003. Role of microfilaments and microtubules in the invasion of INT-407 cells by *Campylobacter jejuni*. *Microbiol. Immunol.* **47**:469-473.
4. **Bourke B, Chan VL, Sherman P.** 1998. *Campylobacter upsaliensis*: Waiting in the wings. *Clin. Microbiol. Rev.* **11**:440-449.
5. **Champion OL, Karlyshev AV, Senior NJ, Woodward M, La Ragione R, Howard SL, Wren BW, Titball RW.** 2010. Insect infection model for *Campylobacter jejuni* reveals that *O*-methyl phosphoramidate has insecticidal activity. *J. Infect. Dis.*
6. **Cundell DR, Gerard NP, Gerard C, Idanpaan-Heikkila I, Tuomanen EI.** 1995. *Streptococcus pneumoniae* anchor to activated human cells by the receptor for platelet-activating factor. *Nature.* **377**:435-438.
7. **Day WA Jr, Sajecki JL, Pitts TM, Joens LA.** 2000. Role of catalase in *Campylobacter jejuni* intracellular survival. *Infect. Immun.* **68**:6337-6345.
8. **Deo DD, Bazan NG, Hunt JD.** 2004. Activation of platelet-activating factor receptor-coupled G alpha q leads to stimulation of Src and focal adhesion kinase via two separate pathways in human umbilical vein endothelial cells. *J. Biol. Chem.* **279**:3497-3508.
9. **Dipineto L, Gargiulo A, Russo TP, De Luca Bossa LM, Borrelli L, Menna LF, Fioretti A.** 2011. *Campylobacter jejuni*, *Campylobacter coli*, and cytolethal distending toxin genes in laying hens. *Avian Dis.* **55**:103-105.
10. **Fillon S, Soulis K, Rajasekaran S, Benedict-Hamilton H, Radin JN, Orihuela CJ, El Kasmi KC, Murti G, Kaushal D, Gaber MW, Weber JR, Murray PJ, Tuomanen EI.** 2006. Platelet-activating factor receptor and innate immunity: Uptake of Gram-positive bacterial cell wall into host cells and cell-specific pathophysiology. *J. Immunol.* **177**:6182-6191.

11. **Fouts DE, Mongodin EF, Mandrell RE, Miller WG, Rasko DA, Ravel J, Brinkac LM, DeBoy RT, Parker CT, Daugherty SC, Dodson RJ, Durkin AS, Madupu R, Sullivan SA, Shetty JU, Ayodeji MA, Shvartsbeyn A, Schatz MC, Badger JH, Fraser CM, Nelson KE.** 2005. Major structural differences and novel potential virulence mechanisms from the genomes of multiple *Campylobacter* species. *PLoS Biol.* **3**:e15.
12. **Gehre F, Spisek R, Kharat AS, Matthews P, Kukreja A, Anthony RM, Dhodapkar MV, Vollmer W, Tomasz A.** 2009. Role of teichoic acid choline moieties in the virulence of *Streptococcus pneumoniae*. *Infect. Immun.* **77**:2824-2831.
13. **Grant CC, Konkel ME, Cieplak W Jr, Tompkins LS.** 1993. Role of flagella in adherence, internalization, and translocation of *Campylobacter jejuni* in nonpolarized and polarized epithelial cell cultures. *Infect. Immun.* **61**:1764-1771.
14. **Guerry P, Ewing CP, Hickey TE, Prendergast MM, Moran AP.** 2000. Sialylation of lipooligosaccharide cores affects immunogenicity and serum resistance of *Campylobacter jejuni*. *Infect. Immun.* **68**:6656-6662.
15. **Guerry P, Szymanski CM, Prendergast MM, Hickey TE, Ewing CP, Pattarini DL, Moran AP.** 2002. Phase variation of *Campylobacter jejuni* 81-176 lipooligosaccharide affects ganglioside mimicry and invasiveness in vitro. *Infect. Immun.* **70**:787-793.
16. **Habib I, Louwen R, Uyttendaele M, Houf K, Vandenberg O, Nieuwenhuis EE, Miller WG, van Belkum A, De Zutter L.** 2009. Correlation between genotypic diversity, lipooligosaccharide gene locus class variation, and caco-2 cell invasion potential of *Campylobacter jejuni* isolates from chicken meat and humans: contribution to virulotyping. *Appl. Environ. Microbiol.* **75**:4277-4288.
17. **Hu L, Kopecko DJ.** 1999. *Campylobacter jejuni* 81-176 associates with microtubules and dynein during invasion of human intestinal cells. *Infect. Immun.* **67**:4171-4182.
18. **Hu L, Tall BD, Curtis SK, Kopecko DJ.** 2008. Enhanced microscopic definition of *Campylobacter jejuni* 81-176 adherence to, invasion of, translocation across, and exocytosis from polarized human intestinal Caco-2 cells. *Infect. Immun.* **76**:5294-5304.
19. **Javed MA, Cawthraw SA, Baig A, Li J, McNally A, Oldfield NJ, Newell DG, Manning G.** 2012. Cj1136 is required for lipooligosaccharide biosynthesis,

hyperinvasion, and chick colonization by *Campylobacter jejuni*. *Infect. Immun.* **80**:2361-2370.

20. **Kanipes MI, Papp-Szabo E, Guerry P, Monteiro MA.** 2006. Mutation of *waaC*, encoding heptosyltransferase I in *Campylobacter jejuni* 81-176, affects the structure of both lipooligosaccharide and capsular carbohydrate. *J. Bacteriol.* **188**:3273-3279.

21. **Karlyshev AV, Everest P, Linton D, Cawthraw S, Newell DG, Wren BW.** 2004. The *Campylobacter jejuni* general glycosylation system is important for attachment to human epithelial cells and in the colonization of chicks. *Microbiology.* **150**:1957-1964.

22. **Keely S, Glover LE, Weissmueller T, MacManus CF, Fillon S, Fennimore B, Colgan SP.** 2010. Hypoxia-inducible factor-dependent regulation of platelet-activating factor receptor as a route for gram-positive bacterial translocation across epithelia. *Mol. Biol. Cell.* **21**:538-546.

23. **Konkel ME, Klena JD, Rivera-Amill V, Monteville MR, Biswas D, Raphael B, Mickelson J.** 2004. Secretion of virulence proteins from *Campylobacter jejuni* is dependent on a functional flagellar export apparatus. *J. Bacteriol.* **186**:3296-3303.

24. **Konkel ME, Mead DJ, Hayes SF, Cieplak W Jr.** 1992. Translocation of *Campylobacter jejuni* across human polarized epithelial cell monolayer cultures. *J. Infect. Dis.* **166**:308-315.

25. **Louwen, R, Heikema, A, van Belkum, A, Ott, A, Gilbert, M, Ang, W, Endtz, HP, Bergman, MP, Nieuwenhuis, EE.** 2008. The sialylated lipooligosaccharide outer core in *Campylobacter jejuni* is an important determinant for epithelial cell invasion. *Infect. Immun.* **76**:4431-4438.

26. **Marrache AM, Gobeil F Jr, Bernier SG, Stankova J, Rola-Pleszczynski M, Choufani S, Bkaily G, Bourdeau A, Sirois MG, Vazquez-Tello A, Fan L, Joyal JS, Filep JG, Varma DR, Ribeiro-Da-Silva A, Chemtob S.** 2002. Proinflammatory gene induction by platelet-activating factor mediated via its cognate nuclear receptor. *J. Immunol.* **169**:6474-6481.

27. **Marrache AM, Gobeil F, Zhu T, Chemtob S.** 2005. Intracellular signaling of lipid mediators via cognate nuclear G protein-coupled receptors. *Endothelium.* **12**:63-72.

28. **McNally DJ, Lamoureux MP, Karlyshev AV, Fiori LM, Li J, Thacker G, Coleman RA, Khieu NH, Wren BW, Brisson JR, Jarrell HC, Szymanski CM.**

2007. Commonality and biosynthesis of the *O*-methyl phosphoramidate capsule modification in *Campylobacter jejuni*. *J. Biol. Chem.* **282**:28566-28576.
29. **Mooney A, Byrne C, Clyne M, Johnson-Henry K, Sherman P, Bourke B.** 2003. Invasion of human epithelial cells by *Campylobacter upsaliensis*. *Cell. Microbiol.* **5**:835-847.
30. **Mooney A, Clyne M, Curran T, Doherty D, Kilmartin B, Bourke B.** 2001. *Campylobacter upsaliensis* exerts a cytolethal distending toxin effect on HeLa cells and T lymphocytes. *Microbiology.* **147**:735-743.
31. **Mortensen NP, Schiellerup P, Boisen N, Klein BM, Locht H, Abuoun M, Newell D, Krogfelt KA.** 2011. The role of *Campylobacter jejuni* cytolethal distending toxin in gastroenteritis: Toxin detection, antibody production, and clinical outcome. *APMIS.* **119**:626-634.
32. **Naito, M, Frirdich, E, Fields, JA, Pryjma, M, Li, J, Cameron, A, Gilbert, M, Thompson, SA, Gaynor, EC.** 2010. Effects of sequential *Campylobacter jejuni* 81-176 lipooligosaccharide core truncations on biofilm formation, stress survival, and pathogenesis. *J. Bacteriol.* **192**:2182-2192.
33. **Nakajima T, Hirayama J, Tazumi A, Hayashi K, Tasaki E, Asakura M, Yamasaki S, Moore JE, Millar BC, Matsuda M.** 2012. Comparative analysis of *Campylobacter lari* cytolethal distending toxin (CDT) effect on HeLa cells. *J. Basic Microbiol.*
34. **Newell DG, McBride H, Dolby JM.** 1985. Investigations on the role of flagella in the colonization of infant mice with *Campylobacter jejuni* and attachment of *Campylobacter jejuni* to human epithelial cell lines. *J. Hyg. (Lond).* **95**:217-227.
35. **Oelschlaeger TA, Guerry P, Kopecko DJ.** 1993. Unusual microtubule-dependent endocytosis mechanisms triggered by *Campylobacter jejuni* and *Citrobacter freundii*. *Proc. Natl. Acad. Sci. U. S. A.* **90**:6884-6888.
36. **Poly F, Read TD, Chen YH, Monteiro MA, Serichantalergs O, Pootong P, Bodhidatta L, Mason CJ, Rockabrand D, Baqar S, Porter CK, Tribble D, Darsley M, Guerry P.** 2008. Characterization of two *Campylobacter jejuni* strains for use in volunteer experimental-infection studies. *Infect. Immun.* **76**:5655-5667.
37. **Radin JN, Orihuela CJ, Murti G, Guglielmo C, Murray PJ, Tuomanen EI.** 2005. beta-Arrestin 1 participates in platelet-activating factor receptor-

mediated endocytosis of *Streptococcus pneumoniae*. Infect. Immun. **73**:7827-7835.

38. **Richardson RM, Marjoram RJ, Barr AJ, Snyderman R.** 2001. RGS4 inhibits platelet-activating factor receptor phosphorylation and cellular responses. Biochemistry. **40**:3583-3588.

39. **Rijneveld AW, Weijer S, Florquin S, Speelman P, Shimizu T, Ishii S, van der Poll T.** 2004. Improved host defense against pneumococcal pneumonia in platelet-activating factor receptor-deficient mice. J. Infect. Dis. **189**:711-716.

40. **Rose A, Kay E, Wren BW, Dallman MJ.** 2011. The *Campylobacter jejuni* NCTC11168 capsule prevents excessive cytokine production by dendritic cells. Med. Microbiol. Immunol.

41. **Snyder F.** 1990. Platelet-activating factor and related acetylated lipids as potent biologically active cellular mediators. Am. J. Physiol. **259**:C697-708.

42. **Swords WE, Buscher BA, Ver Steeg Ii K, Preston A, Nichols WA, Weiser JN, Gibson BW, Apicella MA.** 2000. Non-typeable *Haemophilus influenzae* adhere to and invade human bronchial epithelial cells via an interaction of lipooligosaccharide with the PAF receptor. Mol. Microbiol. **37**:13-27.

43. **Swords WE, Ketterer MR, Shao J, Campbell CA, Weiser JN, Apicella MA.** 2001. Binding of the non-typeable *Haemophilus influenzae* lipooligosaccharide to the PAF receptor initiates host cell signalling. Cell. Microbiol. **3**:525-536.

44. **Thornton JA, Durick-Eder K, Tuomanen EI.** 2010. Pneumococcal pathogenesis: "Innate invasion" yet organ-specific damage. J. Mol. Med. (Berl). **88**:103-107.

45. **van Alphen LB, Bleumink-Pluym NM, Rochat KD, van Balkom BW, Wosten MM, van Putten JP.** 2008. Active migration into the subcellular space precedes *Campylobacter jejuni* invasion of epithelial cells. Cell. Microbiol. **10**:53-66.

46. **Wassenaar TM, Bleumink-Pluym NM, van der Zeijst BA.** 1991. Inactivation of *Campylobacter jejuni* flagellin genes by homologous recombination demonstrates that *flaA* but not *flaB* is required for invasion. EMBO J. **10**:2055-2061.

47. **Watson RO, Galan JE.** 2008. *Campylobacter jejuni* survives within epithelial cells by avoiding delivery to lysosomes. PLoS Pathog. **4**:e14.

48. **Yao R, Burr DH, Doig P, Trust TJ, Niu H, Guerry P.** 1994. Isolation of motile and non-motile insertional mutants of *Campylobacter jejuni*: The role of motility in adherence and invasion of eukaryotic cells. *Mol. Microbiol.* **14**:883-893.

CHAPTER 5

General discussion, conclusions and future perspectives.

5.1 Research purpose

The primary aim of this project was to understand the molecular mechanisms of *Campylobacter upsaliensis* pathogenesis. We focused on the characterization of two putative virulence factors, phosphocholine (PCho) and phosphoramidate (MeOPN), whose biological functions have never been studied in the context of an intestinal pathogen. The research objectives of this thesis were to construct genetic tools that would allow *C. upsaliensis* to be genetically manipulated, and then apply these generated mutants to a series of phenotypical tests to elucidate their function(s) in *C. upsaliensis*. The role of PCho in mucosal bacteria found in the oropharynx and nasopharynx has been extensively defined, and we utilized this knowledge as starting points for the choice of phenotypical tests utilized in this thesis. The study of PCho as well as MeOPN modifications provides further insight into the pathogenesis of *C. upsaliensis*, as well as tools and strategies for future work on *C. upsaliensis* virulence factors.

5.2 Summary of research presented and future directions

5.2.1 Genetic manipulation of *C. upsaliensis* and the conservation of PCho and MeOPN among *Campylobacter* species

The epidemiology of *C. upsaliensis* has been well-characterized over the past 25 years; however, the study of its pathogenesis has been non-existent in comparison to the related pathogen, *Campylobacter jejuni*. Before the onset of this work, there were only a handful of papers that described potential virulence mechanisms and only one that characterized a potential virulence factor, the

production of a cytolethal distending-like toxin (14, 15, 21). In this study, we demonstrated that *C. upsaliensis* is amenable to genetic manipulation when a chloramphenicol acetyltransferase resistant cassette from *Campylobacter coli* is utilized for mutant construction (26). To our knowledge this is the first report of the construction of a genetic mutant in *C. upsaliensis*. The protocol derived in this report can be applied for the future mutation of other putative virulence factors to study their role in *C. upsaliensis* pathogenesis.

Complementation of an isogenic mutant is integral in molecular biology to demonstrate that allelic replacement of the native gene restores mutant functionality to wild-type pathogenesis (4). Unfortunately, all complementation attempts of the *C. upsaliensis* mutants were unsuccessful. *C. upsaliensis* did not retain any of the *C. jejuni* complementation vectors nor did it incorporate the putative *C. upsaliensis* shuttle vector or the two genomic integration vectors designed specifically for this project. The common thread between these complementation attempts was the use of an aminoglycoside phosphotransferase type III (*aphA-3*) kanamycin resistance cassette (13). Classically, chloramphenicol and kanamycin resistance cassettes are used for *C. jejuni* genetic manipulation. The mutation and complementation strategies used in this report were based on the susceptibility of *C. upsaliensis* to these two antibiotics, which was characterized by Fouts and colleagues, as well as confirmed in our own lab (6). Interestingly, *C. upsaliensis* RM3195 is able to form spontaneous kanamycin resistant mutants at a high frequency after subjection to natural transformation,

electroporation or conjugation. The exact mechanism of this spontaneous kanamycin resistance is unknown and has not been reported previously in *C. jejuni*. Environmental *C. jejuni* kanamycin resistant strains usually encode resistance on a plasmid or transposable element (18). Use of the *aphA-3* kanamycin resistance cassette for genetic manipulation in *C. upsaliensis* should be abandoned in future projects, and replaced with another antibiotic resistant cassette. The *C. upsaliensis* complementation vectors generated in this study may be salvaged by the replacement of *aphA-3* with another *Campylobacter*-origin resistant cassette, such as *cj0299*, which encodes a novel β -lactamase from *C. jejuni* (7). The corresponding homolog in *C. upsaliensis* RM3195 has been interrupted by a premature stop codon, resulting in its increased ampicillin susceptibility.

This study also revealed the predicted biosynthetic pathways for MeOPN and PCho are functional, and modify the LOS of *C. upsaliensis* RM3195 with PCho and the CPS with MeOPN. To our knowledge, this is the first report of PCho-modified LOS in an intestinal bacterial pathogen. PCho display was previously thought to be restricted to bacteria involved in diseases such as pneumonia and meningitis.

We also demonstrated that MeOPN biosynthetic pathway is conserved in a number of *Campylobacter* and *Helicobacter* species. The PCho biosynthetic locus is less conserved among *Campylobacters*, but its presence in *C. upsaliensis* correlates with human disease (6).

Interestingly, the expression of MeOPN and PCho is not constant within different strains of *C. upsaliensis* isolated from human, feline or canine origins. Expression of MeOPN was conserved among 12 out of the 13 *C. upsaliensis* isolates examined, while PCho was expressed in only five. This indicates that MeOPN is a prominent surface modification, likely integral to survival of *C. upsaliensis* in varying environments. The function of PCho in *C. upsaliensis* is more likely to provide a competitive edge in a select environmental niche, such as colonization or invasion, as observed for the respiratory mucosal pathogens (3, 5, 19). It is important to note that both MeOPN and PCho biosynthetic clusters appear to be regulated through phase variation. Their absence among some of the *C. upsaliensis* isolates examined could be due to their loci being phased “off.”

5.2.2 *MeOPN and PCho alter C. upsaliensis serum susceptibility*

The second aim of this research project was to elucidate the biological function of MeOPN and PCho on *C. upsaliensis*, and to determine if MeOPN and PCho reacted in a similar manner when subjected to a series of phenotypical tests.

In the respiratory mucosal pathogens, PCho is an immunoreactive cell surface residue that facilitates host clearance by both adaptive and innate immunity (28). The susceptibility of bacteria to human serum is directly related to the inherent immunogenicity of bacterial surface structures and bacterial modification of these moieties to diminish their reactivity. Both MeOPN and PCho are located on the bacterial surface, which suggested a potential role in serum survival.

Presentation of MeOPN and PCho conversely alters *C. upsaliensis* survival in normal human serum through the classical branch of complementation activation. MeOPN display increases *C. upsaliensis* survival in serum. This protective effect may account for its conservation among the Epsilon proteobacteria. This is the first pathogenic function, to our knowledge, reported for MeOPN.

PCho display decreases *C. upsaliensis* serum survival, which is consistent with the serum susceptibility profile displayed by PCho expressing oropharynx and nasopharynx mucosal bacteria (27, 28). The PCho-modified LOS of *Haemophilus influenzae* and *Neisseria meningitidis*, as well as the PCho-modified teichoic acid of *Streptococcus pneumoniae* is recognized and bound by C-reactive protein (CRP) (2, 23, 27). Once bound, the PCho-LOS-CRP complex initiates the classical complement cascade through binding of C1q, facilitating bacterial removal via complement or by opsonization and subsequent removal by a phagocyte (2, 22, 25).

This potential involvement of CRP as well as serum amyloid P component in PCho-mediated clearance and/or MeOPN-protection was tested through two classical binding assays. However it appeared that neither protein bound *C. upsaliensis* whole cells, CPS or LOS, which removed these acute phase pentraxins as possible candidates for the observed serum phenotype.

Currently in collaboration with Roger Ashmus from Dr. Todd Lowary's laboratory, we are preparing PCho-, MeOPN-, CPS- and LOS- conjugated

spharose. Through affinity chromatography of serum, we will be able to elucidate the serum-based moieties responsible for *C. upsaliensis* RM3195 PCho-related killing and MeOPN-mediated protection. We believe through use of a non-selective method such as affinity chromatography, we will be able to uncover the protein(s) responsible for the serum phenotypes observed in this study.

5.2.3 *Host cell invasion is enhanced with modification of C. upsaliensis with MeOPN and PCho*

The final section of this report established that MeOPN and PCho are involved in *C. upsaliensis* adherence and invasion of host intestinal epithelial cells. The LOS and CPS of *C. jejuni* have been consistently implicated in host cell invasion (1, 8-10, 12, 16). Interestingly, the MeOPN mutant in *C. upsaliensis* demonstrates the opposite cell invasion phenotype of a *C. jejuni* mutant.

Preliminary unpublished data generated independently in the Szymanski and Brøndsted labs indicates that *C. jejuni* MeOPN mutants show increased cell invasion (van Alpen, L.B. and Sørensen, M.C.H., personal communication). This discrepancy could be due a possible difference in MeOPN presentation between *C. jejuni* and *C. upsaliensis*. The CPS biosynthetic loci of *C. upsaliensis* have undergone massive rearrangements, including the incorporation of novel genes, compared to *C. jejuni* (6). This indicates that the CPS composition is likely altered and the sugar residue on which the MeOPN is presented may be different, which may impact how the host cells interacts and detects MeOPN.

The decrease in host cell invasion observed for the PCho mutant is consistent with reports by both *H. influenzae* and *S. pneumoniae* for their PCho mutants (3, 19). The PCho-mediated invasion demonstrated by *H. influenzae* and *S. pneumoniae* is modulated by platelet activating factor receptor (PAFR). PCho-decorated LOS or PCho-decorated teichoic acid mimics PAFR's natural ligand, platelet activating factor (PAF) (24). PAF is a proinflammatory chemokine recognized by PAFR via its PCho head group (17, 24). Preincubation of Caco-2 cells with a PAFR antagonist prior to *C. upsaliensis* infection, decreases *C. upsaliensis* invasion to levels comparable to the MeOPN and PCho mutants. This implicated PAFR as a possible receptor for MeOPN- and PCho-mediated cell invasion.

However, we could not detect activated PAFR during an ongoing *C. upsaliensis* infection. Activated PAFR was measured through the detection of phosphorylated PAFR, which has been reported to occur when lipoteichoic acid from *Staphylococcus pyogenes* or *Staphylococcus aureus* bound and activated PAFR (11). It is important to note that *S. pyogenes* and *S. aureus* do not contain PCho-modified lipoteichoic acid. However PCho-decorated teichoic acid and LOS are hypothesized to activate PAFR by the same mechanism due to the similarities in downstream signal transduction (5, 11). Both PCho-decorated and non-decorated moieties have been shown to bind and activate G protein signal transduction, which results in an increased of phosphorylation extracellular-

signal-regulated kinases 1/2 (ERK 1/2), increased cytosolic Ca²⁺ and increased inositol phosphate levels (5, 11, 20).

It is unclear if *C. upsaliensis* is binding PAFR through its MeOPN and/or PCho residues. PAFR can induce signal transduction through G coupled or uncoupled mechanisms, and *C. upsaliensis* could be activating this latter mechanism, for which self-phosphorylation does not occur (5). However, it is possible that the incubation time used to measure PAFR phosphorylation was insufficient, or failure to immunoprecipitate PAFR before use on a Phos-tag gel masked activated PAFR from being detected.

5.3 Conclusions

The study of the molecular mechanisms of disease causation by *C. upsaliensis* is still in its infancy. Reports by Mooney *et al.* and Sylvester *et al.* have provided a foundation for the study of *C. upsaliensis* pathogenesis (14, 15, 21). However these authors never elucidated the biological role of these putative virulence factors in *C. upsaliensis* pathogenesis.

The purpose of this research project was to address the deficiency in the literature concerning *C. upsaliensis* pathogenesis. More specifically, we aimed to identify and elucidate the function of PCho and MeOPN, and the contribution of these phosphorylated moieties to the interaction of *C. upsaliensis* with its surrounding environment. Through the creation of genetic tools to construct mutants in *C. upsaliensis*, we discovered PCho and MeOPN are involved in human serum survival as well as host cell invasion. These results suggest

phosphorylated surface modifications play key roles in *C. upsaliensis* pathogenesis. Further studies based on the tools and mutants developed in this report will provide valuable insight into *C. upsaliensis* bacterial pathogenesis.

5.4 Literature cited

1. **Bacon, DJ, Szymanski, CM, Burr, DH, Silver, RP, Alm, RA, Guerry, P.** 2001. A phase-variable capsule is involved in virulence of *Campylobacter jejuni* 81-176. *Mol. Microbiol.* **40**:769-777.
2. **Casey, R, Newcombe, J, McFadden, J, Bodman-Smith, KB.** 2008. The acute-phase reactant C-reactive protein binds to phosphorylcholine-expressing *Neisseria meningitidis* and increases uptake by human phagocytes. *Infect. Immun.* **76**:1298-1304. doi: 10.1128/IAI.00741-07.
3. **Cundell, DR, Gerard, NP, Gerard, C, Idanpaan-Heikkila, I, Tuomanen, EI.** 1995. *Streptococcus pneumoniae* anchor to activated human cells by the receptor for platelet-activating factor. *Nature.* **377**:435-438. doi: 10.1038/377435a0.
4. **Falkow, S.** 1988. Molecular Koch's postulates applied to microbial pathogenicity. *Rev. Infect. Dis.* **10 Suppl 2**:S274-6.
5. **Fillon, S, Soulis, K, Rajasekaran, S, Benedict-Hamilton, H, Radin, JN, Orihuela, CJ, El Kasmi, KC, Murti, G, Kaushal, D, Gaber, MW, Weber, JR, Murray, PJ, Tuomanen, EI.** 2006. Platelet-activating factor receptor and innate immunity: uptake of gram-positive bacterial cell wall into host cells and cell-specific pathophysiology. *J. Immunol.* **177**:6182-6191.
6. **Fouts, DE, Mongodin, EF, Mandrell, RE, Miller, WG, Rasko, DA, Ravel, J, Brinkac, LM, DeBoy, RT, Parker, CT, Daugherty, SC, Dodson, RJ, Durkin, AS, Madupu, R, Sullivan, SA, Shetty, JU, Ayodeji, MA, Shvartsbeyn, A, Schatz, MC, Badger, JH, Fraser, CM, Nelson, KE.** 2005. Major structural differences and novel potential virulence mechanisms from the genomes of multiple *campylobacter* species. *PLoS Biol.* **3**:e15. doi: 10.1371/journal.pbio.0030015.
7. **Griggs, DJ, Peake, L, Johnson, MM, Ghori, S, Mott, A, Piddock, LJ.** 2009. Beta-lactamase-mediated beta-lactam resistance in *Campylobacter* species: prevalence of Cj0299 (bla OXA-61) and evidence for a novel beta-Lactamase in *C. jejuni*. *Antimicrob. Agents Chemother.* **53**:3357-3364. doi: 10.1128/AAC.01655-08.
8. **Guerry, P, Szymanski, CM, Prendergast, MM, Hickey, TE, Ewing, CP, Pattarini, DL, Moran, AP.** 2002. Phase variation of *Campylobacter jejuni* 81-176 lipooligosaccharide affects ganglioside mimicry and invasiveness in vitro. *Infect. Immun.* **70**:787-793.

9. **Habib, I, Louwen, R, Uyttendaele, M, Houf, K, Vandenberg, O, Nieuwenhuis, EE, Miller, WG, van Belkum, A, De Zutter, L.** 2009. Correlation between genotypic diversity, lipooligosaccharide gene locus class variation, and caco-2 cell invasion potential of *Campylobacter jejuni* isolates from chicken meat and humans: contribution to virulotyping. *Appl. Environ. Microbiol.* **75**:4277-4288. doi: 10.1128/AEM.02269-08.
10. **Javed, MA, Cawthraw, SA, Baig, A, Li, J, McNally, A, Oldfield, NJ, Newell, DG, Manning, G.** 2012. Cj1136 Is Required for Lipooligosaccharide Biosynthesis, Hyperinvasion, and Chick Colonization by *Campylobacter jejuni*. *Infect. Immun.* **80**:2361-2370. doi: 10.1128/IAI.00151-12.
11. **Lemjabbar, H, Basbaum, C.** 2002. Platelet-activating factor receptor and ADAM10 mediate responses to *Staphylococcus aureus* in epithelial cells. *Nat. Med.* **8**:41-46. doi: 10.1038/nm0102-41.
12. **Louwen, R, Heikema, A, van Belkum, A, Ott, A, Gilbert, M, Ang, W, Endtz, HP, Bergman, MP, Nieuwenhuis, EE.** 2008. The sialylated lipooligosaccharide outer core in *Campylobacter jejuni* is an important determinant for epithelial cell invasion. *Infect. Immun.* **76**:4431-4438. doi: 10.1128/IAI.00321-08.
13. **Miller, WG, Bates, AH, Horn, ST, Brandl, MT, Wachtel, MR, Mandrell, RE.** 2000. Detection on surfaces and in Caco-2 cells of *Campylobacter jejuni* cells transformed with new gfp, yfp, and cfp marker plasmids. *Appl. Environ. Microbiol.* **66**:5426-5436.
14. **Mooney, A, Byrne, C, Clyne, M, Johnson-Henry, K, Sherman, P, Bourke, B.** 2003. Invasion of human epithelial cells by *Campylobacter upsaliensis*. *Cell. Microbiol.* **5**:835-847.
15. **Mooney, A, Clyne, M, Curran, T, Doherty, D, Kilmartin, B, Bourke, B.** 2001. *Campylobacter upsaliensis* exerts a cytolethal distending toxin effect on HeLa cells and T lymphocytes. *Microbiology.* **147**:735-743.
16. **Naito, M, Frirdich, E, Fields, JA, Pryjma, M, Li, J, Cameron, A, Gilbert, M, Thompson, SA, Gaynor, EC.** 2010. Effects of sequential *Campylobacter jejuni* 81-176 lipooligosaccharide core truncations on biofilm formation, stress survival, and pathogenesis. *J. Bacteriol.* **192**:2182-2192. doi: 10.1128/JB.01222-09.
17. **Richardson, RM, Marjoram, RJ, Barr, AJ, Snyderman, R.** 2001. RGS4 inhibits platelet-activating factor receptor phosphorylation and cellular responses. *Biochemistry.* **40**:3583-3588.

18. **Sagara, H, Mochizuki, A, Okamura, N, Nakaya, R.** 1987. Antimicrobial resistance of *Campylobacter jejuni* and *Campylobacter coli* with special reference to plasmid profiles of Japanese clinical isolates. *Antimicrob. Agents Chemother.* **31**:713-719.
19. **Swords, WE, Buscher, BA, Ver Steeg Ii, K, Preston, A, Nichols, WA, Weiser, JN, Gibson, BW, Apicella, MA.** 2000. Non-typeable *Haemophilus influenzae* adhere to and invade human bronchial epithelial cells via an interaction of lipooligosaccharide with the PAF receptor. *Mol. Microbiol.* **37**:13-27.
20. **Swords, WE, Ketterer, MR, Shao, J, Campbell, CA, Weiser, JN, Apicella, MA.** 2001. Binding of the non-typeable *Haemophilus influenzae* lipooligosaccharide to the PAF receptor initiates host cell signalling. *Cell. Microbiol.* **3**:525-536.
21. **Sylvester, FA, Philpott, D, Gold, B, Lastovica, A, Forstner, JF.** 1996. Adherence to lipids and intestinal mucin by a recently recognized human pathogen, *Campylobacter upsaliensis*. *Infect. Immun.* **64**:4060-4066.
22. **Szalai, AJ, Agrawal, A, Greenhough, TJ, Volanakis, JE.** 1997. C-reactive protein: structural biology, gene expression, and host defense function. *Immunol. Res.* **16**:127-136.
23. **Szalai, AJ, Briles, DE, Volanakis, JE.** 1996. Role of complement in C-reactive-protein-mediated protection of mice from *Streptococcus pneumoniae*. *Infect. Immun.* **64**:4850-4853.
24. **Thornton, JA, Durick-Eder, K, Tuomanen, EI.** 2010. Pneumococcal pathogenesis: "innate invasion" yet organ-specific damage. *J. Mol. Med. (Berl)*. **88**:103-107. doi: 10.1007/s00109-009-0578-5.
25. **Volanakis, JE, Kaplan, MH.** 1974. Interaction of C-reactive protein complexes with the complement system. II. Consumption of guinea pig complement by CRP complexes: requirement for human C1q. *J. Immunol.* **113**:9-17.
26. **Wang, Y, Taylor, DE.** 1990. Chloramphenicol resistance in *Campylobacter coli*: nucleotide sequence, expression, and cloning vector construction. *Gene.* **94**:23-28.
27. **Weiser, JN, Pan, N, McGowan, KL, Musher, D, Martin, A, Richards, J.** 1998. Phosphorylcholine on the lipopolysaccharide of *Haemophilus influenzae* contributes to persistence in the respiratory tract and sensitivity to serum killing mediated by C-reactive protein. *J. Exp. Med.* **187**:631-640.

28. **Weiser, JN, Shchepetov, M, Chong, ST.** 1997. Decoration of lipopolysaccharide with phosphorylcholine: a phase-variable characteristic of *Haemophilus influenzae*. *Infect. Immun.* **65**:943-950.

APPENDIX

APPENDIX 1

**Phosphoramidate and phosphocholine expression does not influence
Campylobacter upsaliensis polymyxin B sensitivity, bacterial survival in a
Galleria mellonella pathogenesis model or biofilm formation.**

A1.1 Introduction

The carbohydrate composition of the capsular polysaccharides (CPS) is highly variable among *Campylobacter* species and currently over 60 different capsule structures have been identified through the Penner serotyping scheme. Recently, a unique phosphoramidate (MeOPN) CPS modification has been identified, which was present among 68 % of *Campylobacter jejuni* isolates examined (12). The MeOPN modification appears to be present in a number of Epsilon proteobacteria, with its biosynthetic pathway highly conserved among *Campylobacter* and *Helicobacter* species (Chapter 2, Figure 2.1). It is interesting to note, that the MeOPN putative nucleotidyltransferase shares homology with the phosphocholine (PCho) cytidylyltransferase, *licC* (12). The PCho modification is conserved among a variety of commensal bacteria and opportunistic pathogens present in the human oropharynx and nasopharynx mucosa and is predicted to be present in only three *Campylobacter* species (8).

Both of these modifications share similar features in structure and predicted biosynthesis. Interestingly, MeOPN has not previously been observed in nature and resembles man-made pesticides. The emerging pathogen *Campylobacter upsaliensis* modifies its CPS with MeOPN and its lipooligosaccharides (LOS) with PCho. Therefore, this organism provides a model to study both phosphorylated modifications and elucidate if either plays similar roles as described for the PCho moieties decorating the mucosal pathogens.

This study was undertaken to determine whether MeOPN and/or PCho had an influence on bacterial polymyxin B susceptibility, *G. mellonella* pathogenesis or biofilm formation. There was no significant difference between wild type and mutants for any of these assays.

A1.2 Material and Methods

A1.2.1 Bacterial strains and growth conditions

The bacterial strains used in this study are listed in Table A1.1. The *C. upsaliensis* strain RM3195 (ATCC BAA-1059, Manassas, VA, USA) was originally obtained from the feces of a 4-year-old Guillain-Barré patient and its genome later sequenced by Fouts and colleagues (6). The construction and phenotypic testing of the MeOPN mutant, *Cup_0802::cat*, and the PCho mutant, *licC::cat*, are described in Chapter 2.

Table A1.1 Strains used in this study.

Strain	Description	Reference or source
RM3195 wt	Human clinical isolate	(6)
RM3195 <i>licC::cat</i>	RM3195; <i>licC</i> mutant, Cm ^R	Chapter 2
RM3195 <i>Cup_0802::cat</i>	RM3195; <i>CUP_0802</i> mutant, Cm ^R	Chapter 2

All *C. upsaliensis* strains were routinely grown on Blood Agar Base No. 2 (Oxoid, Basingstoke, Hampshire, UK) which was supplemented with 7 % Horse Blood (Quadfive, Ryegate, MT) and 1 % Yeast Extract (BD/Bacto, Franklin Lakes, NJ, USA) grown at 37 °C under microaerobic conditions (85 % N₂, 10 %

CO₂ and 5 % O₂). Chloramphenicol (Cm) (Sigma-Aldrich, Oakville, ON) was added to the agar plates at a final concentration of 20 µg ml⁻¹.

For biphasic growth, upright 25 cm² tissue culture flasks were filled with 5 ml of Brain Heart Infusion broth (BD/Difco) supplemented with 1% Yeast Extract (BHIY) plus 1.5 % agar and 5 ml of BHIY broth was added on top of the solidified agar. *C. upsaliensis* from 16 h plates was used to inoculate upright flasks which were incubated at 37 °C under microaerobic conditions with shaking at 140 rpm. Antibiotics were not added to the biphasic media. RM3195 did not grow in biphasic flasks without shaking.

A1.2.2 Polymyxin B minimum inhibitory concentration (MIC)

C. upsaliensis strains were grown in biphasic flasks overnight, standardized to an OD₆₀₀ of 0.35 (5 x 10⁷ CFU ml⁻¹) in 5 ml of BHIY, and incubated under microaerobic conditions for 5 h. After this incubation period, BHIY plus 0.4 % agar was inoculated with 500 µl of the bacterial suspension, solidified at room temperature for 15 min and an E-test strip (bioMérieux SA, Marcy-l'Étoile, FR) placed on the agar overlay. After 48 h of incubation under standard growth conditions, the minimum inhibitory concentration (MIC) was recorded. Values are the MIC of three independent experiments repeated in duplicate, with standard deviations.

A1.2.3 Polymyxin B sensitivity

C. upsaliensis strains were grown overnight in biphasic media, pelleted by centrifugation at 4,000 x g for 10 min, then resuspended in HEPES buffer, pH =

7.4. This bacterial suspension was then diluted to a final OD₅₅₀ of 0.05 (1×10^7 CFU ml⁻¹) in HEPES buffer and 10 µg ml⁻¹ (wt vol⁻¹) of polymyxin B (Sigma-Aldrich). The bacteria-antibiotic mixture was incubated in 24-well plates at 37 °C under microaerobic conditions, with shaking at 90 rpm for 2 h. *C. upsaliensis* was serially diluted and plated on Blood agar. Values are the CFU of three independent experiments repeated in duplicate, with standard deviations.

A1.2.4 Galleria mellonella pathogenesis model

C. upsaliensis strains were grown overnight on Blood agar, resuspended in 40 mM MgSO₄ buffer and normalized to OD₅₅₀ of 5 (1×10^9 CFU ml⁻¹). *G. mellonella* larvae (Bugorder.com, Morinville, AB) were briefly placed on ice before injection with a syringe (Hamilton, Reno, NV, USA) in the right foreleg with 10 µl of the *C. upsaliensis* culture. The larvae were incubated aerobically at 37°C and survival after 24 h was recorded. Negative 40 mM MgSO₄ buffer injection controls were performed in parallel. The experiment was repeated in three independent trials with ten *G. mellonella* larvae per experiment. Data are represented as percent survival with standard deviations.

A1.2.5 Biofilm assay

The biofilm assays were performed as previous described by McLennan *et. al.* with modification (11). *C. upsaliensis* strains were grown overnight on Blood agar, resuspended in BH1Y and diluted to an OD₆₀₀ of 0.05 (8×10^6 CFU ml⁻¹). Glass test tubes were inoculated with 2 ml, while 96-well microtitre polypropylene plates were inoculated with 300 µl of bacterial suspension and both

experiments were incubated for 96 h at 37 °C under microaerobic condition with shaking. Again, shaking was needed in this assay to observe biofilm growth at the air-liquid interface. After 96 h, 25 µl of a 1 % crystal violet (Sigma-Aldrich) solution in 95 % ethanol (CV) was added to the 96-well plates, while 100 µl of CV was added to the test tubes. The solution was incubated at room temperature for 15 min to allow penetration of the stain into the biofilm matrix. The tubes were then rinsed with distilled water until the CV stopped leaching into solution and air dried. Biofilms were quantified by solubilizing the remaining CV with dimethyl sulfoxide (Bioshop, Burlington, ON) and measuring the absorbance at 570 nm with a spectrophotometer.

A1.3 Results and Discussion

A1.3.1 MeOPN and PCho expression does not influence polymyxin B sensitivity

Polymyxin B is an antibiotic characterized by its cationic cyclic peptide ring attached to a fatty acid N-terminal tail (18). It readily disrupts the outer membrane of Gram-negative bacteria through its electrostatic attraction for the negative charge of the lipid A component of LOS and lipopolysaccharide (LPS). Once associated with the outer membrane, it disrupts LOS/LPS packing and the hydrophobic tail penetrates the cytoplasmic membrane (5). Resistance to polymyxin B is usually achieved through the reduction of the negative charge of the lipid A. *Salmonella enterica* serovar Typhimurium prevents the bactericidal actions of polymyxin B and cationic antimicrobial peptides through the modification of its lipid A with 4-amino-4-deoxy-L-arabinose and/or

phosphoethanolamine through induction of the PmrA-PmrB regulatory system (7, 17). *C. jejuni* also modifies its lipid A with phosphoethanolamine, and its removal increases bacterial sensitivity to polymyxin B (4). Since *C. upsaliensis* appears to produce a truncated form of the phosphoethanolamine transferase homologue of *C. jejuni*, EptC, we hypothesized that MeOPN and PCho may provide some further neutralization of the overall negative surface charge of *C. upsaliensis* through their zwitterionic nature, and therefore aid in resistance to polymyxin B.

The polymyxin B sensitivity of *C. upsaliensis* was tested by two separate methods; an E-test strip MIC calculation and a polymyxin B survival assay. Both of these procedures demonstrated that there was no difference in polymyxin B susceptibility between the wild type and mutants (Figure A1.1, Table A1.2.). There was no significant difference between the MIC of RM3195 wt, *Cup_0802::cat* or *licC::cat* (Table A1.2), and there was no significant difference in survival in $10\mu\text{g ml}^{-1}$ of polymyxin B over 2h (Figure A1.1).

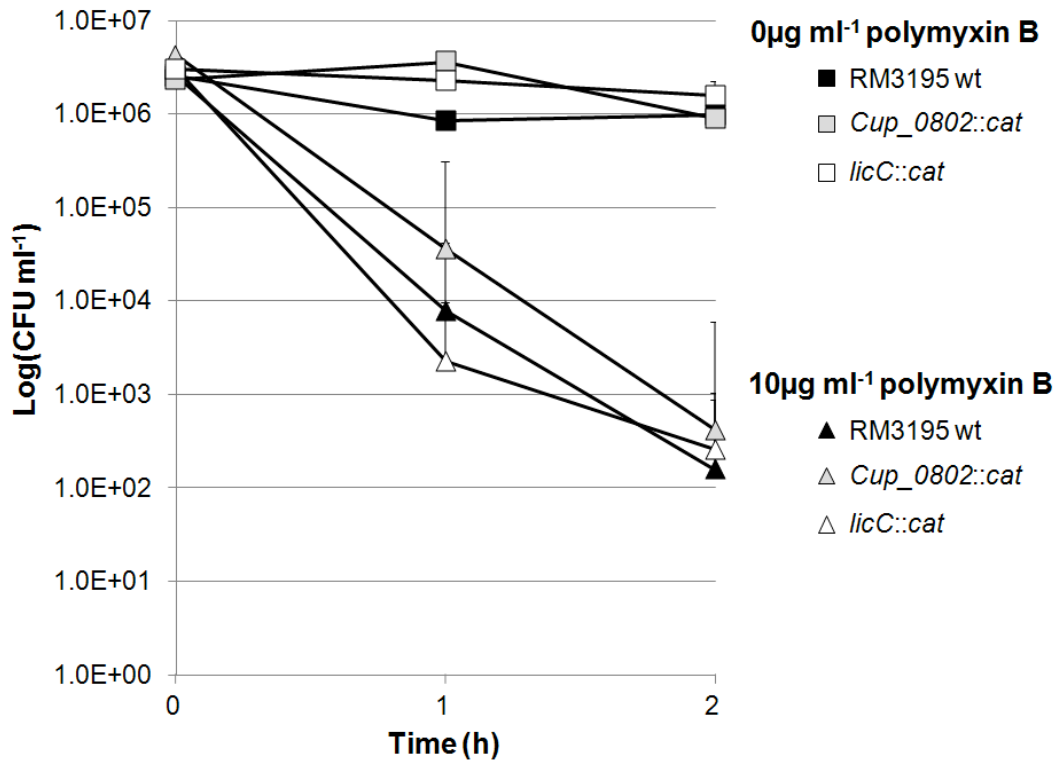

Figure A1.1 Display of PCho or MeOPN does not influence survival of *C. upsaliensis* in polymyxin B. Incubation of RM3195 wt, *Cup_0802::cat* and *licC::cat* over 2h of incubation in either 0 µg ml⁻¹ or 10 µg ml⁻¹ polymyxin B. All CFU ml⁻¹ counts are means of two separate trials in triplicate ± standard deviation.

Table A1.2 Minimal inhibitory concentration of polymyxin B for *C. upsaliensis*.

<i>C. upsaliensis</i> strain	Polymyxin B MIC (µg ml ⁻¹)*	Presence of PCho	Presence of MeOPN
RM3195	0.21±0.03	+	+
<i>licC::cat</i>	0.23±0.05	-	+
<i>CUP_0802::cat</i>	0.19±0	+	-

*Minimal inhibitory concentration (MIC) calculated using Polymyxin B E-Test strips (bioMérieux)

Interestingly, *C. upsaliensis* is hypersensitive to polymyxin B. The polymyxin B MIC of *C. jejuni* 81-176 is $17.3 \mu\text{g ml}^{-1}$ compared to RM3195 wt of $0.21 \mu\text{g ml}^{-1}$ observed in this study (4). This increased polymyxin B susceptibility is consistent with the presence of a truncated RM3195 putative phosphoethanolamine transferase, EptC, by the premature insertion of a stop codon. Mutation of *eptC* in *C. jejuni* 81-176 resulted in a 20-fold increase in polymyxin B sensitivity (MIC = $0.8 \pm 0.2 \mu\text{g ml}^{-1}$), which is comparable with the polymyxin B MICs for RM3195 wt, *licC::cat* and *Cup_0802::cat* (Table A1.2) (4). The structure of the LOS of *C. upsaliensis* RM3195 has not been solved, but based on the polymyxin B data presented here and the genome sequence, we hypothesize that the LOS inner core and lipid A will not be modified with phosphoethanolamine.

PCho has been reported to decrease susceptibility to the cationic antimicrobial peptide LL-37/hCAP18 and a PCho *Haemophilus influenzae* mutant is 1,000-fold more sensitive to its bactericidal effects (10). However, there are no studies that have reported PCho can act as a replacement for phosphoethanolamine to restore polymyxin B resistance. *H. influenzae* adds PCho to either its heptose I or heptose III residue on its LOS, but also modifies its heptose II with phosphoethanolamine (14). It appears that the PCho modification of *C. upsaliensis* LOS cannot compensate for potential lack of phosphoethanolamine.

The inability of MeOPN to effect polymyxin B sensitivity is consistent with CPS mutant data from *C. jejuni*. Capsules have been previously reported in other bacteria such as *Klebsiella* and *Neisseria* to increase polymyxin B resistance (2, 16). However, CPS mutants in *C. jejuni*, which intrinsically are MeOPN mutants, played no major role in polymyxin B resistance (9).

A1.3.2 Pathogenesis in a Galleria mellonella model is not influenced by MeOPN and PCho expression

Galleria mellonella larvae have been previously shown to be a potential *Campylobacter* pathogenesis model and *G. mellonella* is rapidly killed within 24 hours at 37°C (3, 15). However disruption to the MeOPN biosynthetic genes significantly attenuated this virulence (3).

C. upsaliensis RM3195 wt, *Cup_0802::cat* and *licC::cat* were tested in a *G. mellonella* larvae pathogenesis model. After three trials utilizing 10 larvae each, no significant difference in larvae death was observed between strains (Figure A1.2). All larvae in the 40mM MgSO₄ injection control group survived, indicating that the larvae killing observed in the injection experiments was due to *C. upsaliensis* infection and not needle error. Low survival of larvae injected with the MeOPN biosynthetic mutant is contrary to a previously published report examining *C. jejuni* 11168 as well as with *C. jejuni* 81-176 MeOPN mutants generated in our lab (3, van Alphen, L.B. unpublished). The MeOPN-dependent killing observed by Champion and colleagues could be a *C. jejuni* specific effect or an artifact. *C. upsaliensis* killing of *G. mellonella* could be dependent on other

factors than MeOPN, and therefore removal of MeOPN would only have a minor impact on larvae survival. This could account for the non-significant increase from 59 ± 5.8 % in survival observed for *Cup_0802::cat* compared to 46 ± 5.0 % for RM3195 wt.

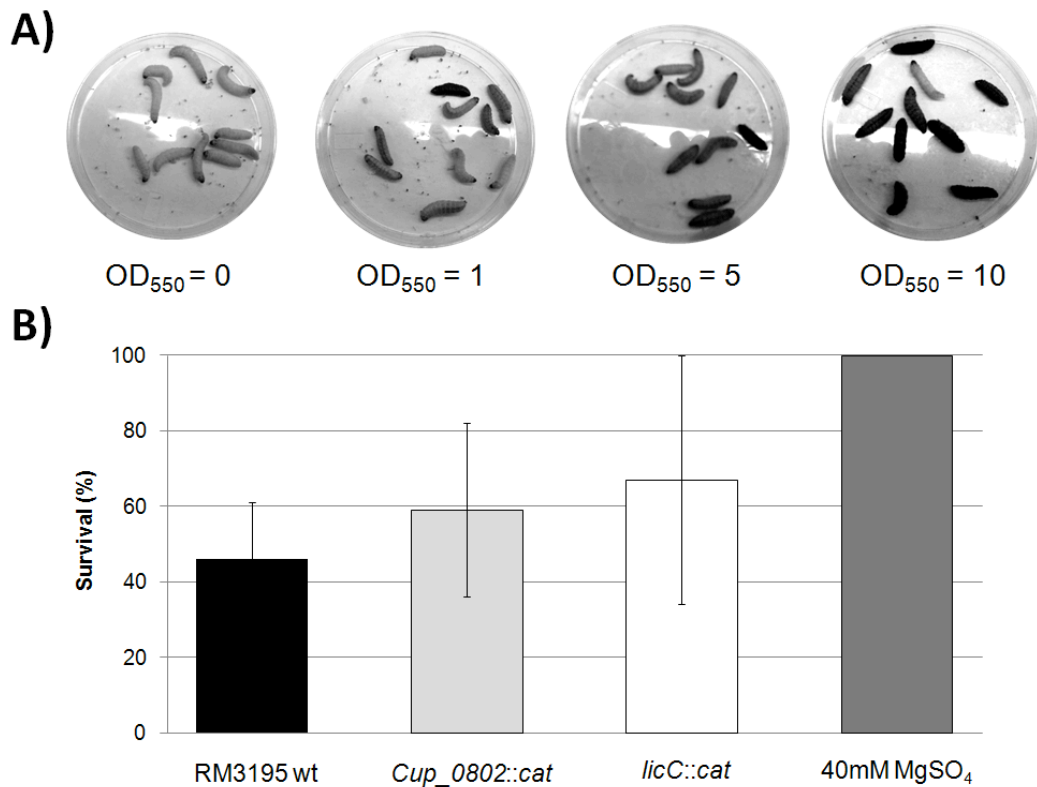

Figure A1.2 Display of PCho or MeOPN does not influence survival of *C. upsaliensis* in a *G. mellonella* infection model. **A)** Photographs of *G. mellonella* larvae survival with RM3195 wt injection. White larvae were healthy and alive, while black larvae had undergone advanced melanization, followed shortly by death. **B)** Percent survival of larvae after injection with RM3195 wt, *Cup_0802::cat* or *licC::cat* at an OD₅₅₀ = 5. Percent survival is the mean of three separate trials, each with 10 larvae per group, after incubation at 37 °C for 24 h ±

standard deviation. The 100 % value was equal to all ten *G. mellonella* larvae surviving the 24 h incubation.

A1.3.3 Biofilm formation is not altered by modification with MeOPN and PCho

PCho has been reported to aid in the maturation (increased thickness, surface cover and total biomass) of *H. influenzae* biofilms both *in vitro* as well as *in vivo* in the chinchilla model of otitis media (1). It also appears that *C. jejuni* MeOPN may aid in the formation of biofilms (van Alphen, personal communication).

Utilizing a 96-well plate and test tube *Campylobacter* biofilm assay (adapted for *C. upsaliensis*), biofilm formation was compared between RM3195 wt, *Cup_0802::cat* and *licC::cat*. However no significant difference was observed (Figure A1.3). Interestingly, *C. upsaliensis* was unable to form biofilms over the 96 hour time period unless it was shaking. This is atypical of biofilms formed by *C. jejuni*, which are only formed when bacteria are grown in stationary culture (13).

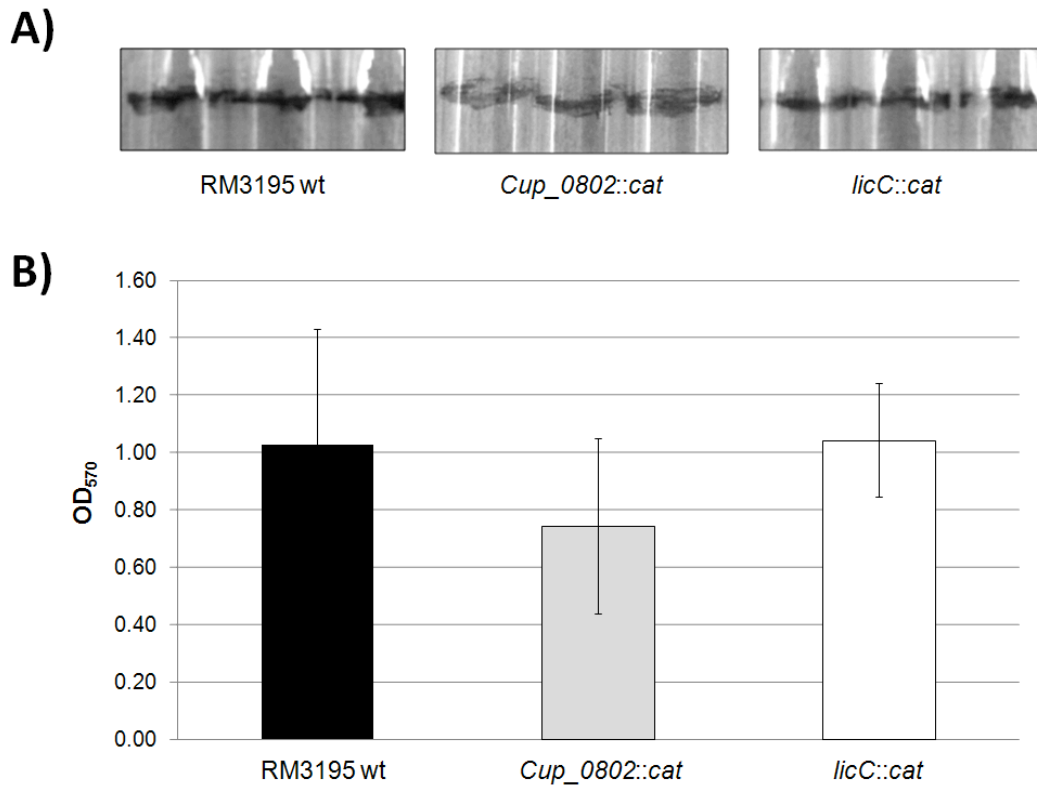

Figure A1.3 Display of PCho or MeOPN does not influence biofilm formation of *C. upsaliensis*. **A)** Photographs of crystal violet stained 96h biofilms of RM3195 wt, *Cup_0802::cat* and *licC::cat*. **B)** Absorbance of solubilized crystal violet stained biofilms from microtitre plate assays read at OD₅₇₀. The OD₅₇₀ is the mean of three separate trials with 10 wells each on a 96-well plate after incubation at 37 °C for 96 h ± standard deviation.

MeOPN and PCho modification of *C. upsaliensis* is important for its pathogenesis. Both phosphorylated moieties play significant roles in serum survival (Chapter 3) and host cell invasion (Chapter 4), but based on the work presented here, neither modification impacts polymyxin B survival, *G. mellonella*

pathogenesis or biofilm formation. However, the polymyxin B MIC provides new information, such as the potential loss of a phosphoethanolamine modification, on the unsolved *C. upsaliensis* LOS structure. The inability of *C. upsaliensis* to reproduce the MeOPN-dependent *G. mellonella* killing as observed for *C. jejuni* has raised concerns about this species-dependent lethality. Current investigations in our laboratory are targeted toward determining whether the published affect of *C. jejuni* MeOPN on *G. mellonella* survival may be artificial.

A1.4 Acknowledgements

The authors would like to thank Christopher Fodor for his assistance with the *G. mellonella* assay.

A1.5 Literature cited

1. **Armbruster CE, Hong W, Pang B, Dew KE, Juneau RA, Byrd MS, Love CF, Kock ND, Swords NE.** 2009. LuxS promotes biofilm maturation and persistence of nontypeable *Haemophilus influenzae in vivo* via modulation of lipooligosaccharides on the bacterial surface. *Infect. Immun.* **77**:4081-4091.
2. **Campos MA, Vargas MA, Regueiro V, Llompert CM, Alberti S, Bengoechea JA.** 2004. Capsule polysaccharide mediates bacterial resistance to antimicrobial peptides. *Infect. Immun.* **72**:7107-7114.
3. **Champion OL, Karlyshev AV, Senior NJ, Woodward M, La Ragione R, Howard SL, Wren BW, Titball RW.** 2010. Insect infection model for *Campylobacter jejuni* reveals that O-methyl phosphoramidate has insecticidal activity. *J. Infect. Dis.*
4. **Cullen TW, Trent MS.** 2010. A link between the assembly of flagella and lipooligosaccharide of the Gram-negative bacterium *Campylobacter jejuni*. *Proc. Natl. Acad. Sci. USA.* **107**:5160-5165.
5. **Fidai S, Farmer SW, Hancock RE.** 1997. Interaction of cationic peptides with bacterial membranes. *Methods Mol. Biol.* **78**:187-204.
6. **Fouts DE, Mongodin EF, Mandrell RE, Miller WG, Rasko DA, Ravel J, Brinkac LM, DeBoy RT, Parker CT, Daugherty SC, Dodson RJ, Durkin AS, Madupu R, Sullivan SA, Shetty JU, Ayodeji MA, Shvartsbeyn A, Schatz MC, Badger JH, Fraser CM, Nelson KE.** 2005. Major structural differences and novel potential virulence mechanisms from the genomes of multiple *Campylobacter* species. *PLoS Biol.* **3**:e15.
7. **Gibbons HS, Kalb SR, Cotter RJ, Raetz CR.** 2005. Role of Mg²⁺ and pH in the modification of *Salmonella* lipid A after endocytosis by macrophage tumour cells. *Mol. Microbiol.* **55**:425-440.
8. **Gillespie SH, Ainscough S, Dickens A, Lewin J.** 1996. Phosphorylcholine-containing antigens in bacteria from the mouth and respiratory tract. *J. Med. Microbiol.* **44**:35-40.
9. **Keo T, Collins J, Kunwar P, Blaser MJ, Iovine NM.** 2011. *Campylobacter* capsule and lipooligosaccharide confer resistance to serum and cationic antimicrobials. *Virulence.* **2**:30-40.
10. **Lysenko ES, Gould J, Bals R, Wilson JM, Weiser JN.** 2000. Bacterial phosphorylcholine decreases susceptibility to the antimicrobial peptide LL-

37/hCAP18 expressed in the upper respiratory tract. *Infect. Immun.* **68**:1664-1671.

11. **McLennan MK, Ringoir DD, Frirdich E, Svensson SL, Wells DH, Jarrell H, Szymanski CM, Gaynor EC.** 2008. *Campylobacter jejuni* biofilms up-regulated in the absence of the stringent response utilize a calcofluor white-reactive polysaccharide. *J. Bacteriol.* **190**:1097-1107.

12. **McNally DJ, Lamoureux MP, Karlyshev AV, Fiori LM, Li J, Thacker G, Coleman RA, Khieu NH, Wren BW, Brisson JR, Jarrell HC, Szymanski CM.** 2007. Commonality and biosynthesis of the O-methyl phosphoramidate capsule modification in *Campylobacter jejuni*. *J. Biol. Chem.* **282**:28566-28576.

13. **Naito M, Frirdich E, Fields JA, Pryjma M, Li J, Cameron A, Gilbert M, Thompson SA, Gaynor EC.** 2010. Effects of sequential *Campylobacter jejuni* 81-176 lipooligosaccharide core truncations on biofilm formation, stress survival, and pathogenesis. *J. Bacteriol.* **192**:2182-2192.

14. **Richards JC, Cox AD, Schweda EK, Martin A, Hood DW, Moxon ER.** 2001. Structure and functional genomics of lipopolysaccharide expression in *Haemophilus influenzae*. *Adv. Exp. Med. Biol.* **491**:515-524.

15. **Senior NJ, Bagnall MC, Champion OL, Reynolds SE, La Ragione RM, Woodward MJ, Salguero FJ, Titball RW.** 2011. *Galleria mellonella* as an infection model for *Campylobacter jejuni* virulence. *J. Med. Microbiol.* **60**:661-669.

16. **Spinosa MR, Progida C, Tala A, Cogli L, Alifano P, Bucci C.** 2007. The *Neisseria meningitidis* capsule is important for intracellular survival in human cells. *Infect. Immun.* **75**:3594-3603.

17. **Tamayo R, Choudhury B, Septer A, Merighi M, Carlson R, Gunn JS.** 2005. Identification of *cptA*, a PmrA-regulated locus required for phosphoethanolamine modification of the *Salmonella enterica* serovar Typhimurium lipopolysaccharide core. *J. Bacteriol.* **187**:3391-3399.

18. **Vaara M, Porro M.** 1996. Group of peptides that act synergistically with hydrophobic antibiotics against Gram-negative enteric bacteria. *Antimicrob. Agents Chemother.* **40**:1801-1805.

APPENDIX 2

Phase variable expression of capsular polysaccharides modifications allows

***Campylobacter jejuni* to avoid bacteriophage infection in chickens**

(The following text was written by M.C.H. Sørensen and L.B. van Alphen, with corrections added by C. Fodor C., S.M. Crowley, B.B. Christensen, C.M. Szymanski and L. Brøndsted)

Adapted from: Sørensen M.C.H., van Alphen L.B., Fodor C., Crowley S.M., Christensen B.B., Szymanski C.M. and Brøndsted L. (2012) Phase variable expression of capsular polysaccharide modifications allows *Campylobacter jejuni* to avoid bacteriophage infection in chickens. *Front. Cell. Inf. Microbio.* **2**:11. doi: 10.3389/fcimb.2012.00011. Permission to reproduce figures and tables was obtained from the journal. Tables are adapted to fit thesis format.

Contributions: I conducted the HR-MAS NMR and plaquing experiments for the chicken studies described in this paper.

A2.1 Introduction

Bacteriophages (phages) are the most abundant group of organisms on the planet and are estimated to outnumber their bacterial hosts by tenfold (3). The first step of phage infection is through the specific recognition and attachment of the phage particle to the host cell (39). In general, phages bind to unique host-specific structures, thus allowing them to recognize a suitable host in a mixed bacterial population (30). Knowledge of phage receptors is required for implementation of efficient phage therapies against human pathogens – an intervention strategy that has been promoted by the increasing occurrence of antibiotic resistance (20, 21), yet only a few bacterial phage receptors have been identified in Gram-negative bacteria (for example, (12, 13, 27, 36, 40)).

Capsular polysaccharides (CPS) are highly hydrated polymeric gels that provide a thick (400 nm or more) layer protecting bacteria from hostile

environments and host immune defenses, but the CPS can also be a target for phage binding and infection (6, 32, 36). The capsule of the zoonotic foodborne pathogen, *Campylobacter jejuni*, is required for serum resistance, invasion of human epithelial cells, colonization of chickens and diarrheal disease in ferrets (1, 18). Furthermore, mutation of several *C. jejuni* CPS genes resulted in phage resistance against a group of phages, but the actual capsular moieties involved were not identified (8). Only recently a specific component of the *C. jejuni* capsule was identified as the phage receptor for this species. We showed that phage F336 relies on the *O*-methyl phosphoramidate (MeOPN) modification of the *C. jejuni* NCTC11168 CPS for adsorption to the host cell surface and infection (34).

The CPS of *C. jejuni* is the major component recognized by the Penner serotyping scheme for which 47 different serotypes are known (14). Thus, the capsular polysaccharides are highly diverse in structure and this is reflected by the gene content of the capsular loci in various *C. jejuni* strains (19). In addition, a number of CPS genes possess homopolymeric tracts making them prone to phase variation which allows a rapid on/off switching of the genes and promotes variations in CPS even when the strains have identical gene contents (5, 19, 22, 24, 35). The CPS of *C. jejuni* 11168 consists of $-2)-\beta\text{-D-Ribf-(1-5)-3-MeOPN-}\beta\text{-D-GalfNAc-(1-4)-}\alpha\text{-D-GlcpA6(NGro)-(1-backbone with a 3,6-di-}O\text{-methyl-4-MeOPN-D-glycero-}\alpha\text{-L-gluco-Hepp side chain (24, 35, 37). The CPS biosynthetic locus in strain NCTC11168 includes 28 genes and six of these genes (}cj1420,$

cj1421, *cj1422*, *cj1426*, *cj1429* and *cj1437*) contain homopolymeric G (polyG) tracts (29). Even though the function of only three out of the six gene products has been identified, a highly variable presence/absence of methyl, ethanolamine, aminoglycerol and phosphoramidate modifications of the CPS have been observed (24, 35, 37), suggesting that the remaining genes could encode enzymes involved in synthesis or transfer of these modifications to the CPS glycans. Recently, the *cj1421* and *cj1422* genes were shown to encode MeOPN transferases attaching MeOPN to the Gal/NAc and the Hep residues, respectively (25). Similarly, *cj1426* was demonstrated to encode the 6-O-Me transferase enzyme.

We previously discovered that resistance towards phage F336 evolved with a high frequency in *C. jejuni* NCTC11168 due to loss of the MeOPN receptor on the bacterial surface as a result of phase variation in the *cj1421* gene encoding the MeOPN-Gal/NAc transferase. In addition, deletion of the *cj1421* gene in NCTC11168 resulted in phage resistance, proving that MeOPN attached to Gal/NAc was a receptor for phage F336 (34). The aim of the present study was to determine if other phages rely on the MeOPN moiety for infection of *C. jejuni* and to explore the role of other CPS phase variable modifications for phage infection. Knowledge of phage receptors and development of phage resistance *in vivo* is essential for implementation of efficient phage therapy against *C. jejuni* in the chicken gut. We found that not only the MeOPN moiety, but also the phase variable 3-O-Me and 6-O-Me groups in the CPS of *C. jejuni* NCTC11168 may

influence phage sensitivity. Co-infection of chickens with *C. jejuni* NCTC11168 and phage F336 resulted in bacterial acquisition of phage resistance through a loss of MeOPN attached to Gal/NAc of the capsule or the acquisition of the 6-O-Me group. We propose that the constant exposure of *C. jejuni* to naturally occurring phages in the avian gut selects for different phase variable structures of the CPS resulting in a continuous phage-host co-evolution.

A2.2 Material and Methods

A2.2.1 Bacterial strains, media and growth conditions

The *C. jejuni* strains used in this study are listed in Table A2.1 and were routinely grown on blood agar Base II (Oxoid) supplemented with 5 % calf blood (BA) or in brain heart infusion broth (BHI) under microaerobic conditions (6% CO₂, 6% O₂, 84% N₂ and 4% H₂) at 37°C. For chicken experiments, bacteria were grown on Karmali agar (Oxoid) supplemented with Campylobacter selective supplement under microaerobic conditions (10% CO₂, 5% O₂, 85% N₂) at 37°C.

Table A2.1 *Campylobacter jejuni* strains.

Strain	Serotype	Description	Reference or source
1447	HS:4c	Chicken isolate	(16)
NCTC12662	HS:5j	Unknown	NCTC, UK
NCTC11168 (MP21)	HS:2	Wild type	(34)
NCTC11168 (MP24)	HS:2	NCTC11168 variant passaged	This study
NCTC11168 (MP25)	HS:2	NCTC11168 variant passaged	This study
NCTC11168 (MP26)	HS:2	NCTC11168 variant passaged	This study
NCTC11168 (V26)	HS:2	NCTC11168 variant	(4)
<i>kpsM</i>	Untypeable	NCTC11168 <i>kpsM::kan</i> does not have capsule	(19)
11168R		Phage F336 resistant NCTC11168	(34)
S11168R		Phage-sensitive 11168R	(34)
11168H	HS:2	Hypermotile NCTC11168	(18)
11168H Δ 1421		Loss of MeOPN on Gal/NAc	(25)
11168H Δ 1421/1422		Loss of MeOPN on Gal/NAc and Hep	(25)
11168H Δ 1422		Loss of MeOPN on Hep	(25)
11168H Δ 1421/1422 +1422		Loss of MeOPN on Gal/NAc, gain of MeOPN on Hep	(25)
11168H1		11168H variant, loss of 6-O-Me and MeOPN on Hep	This study

A2.2.2 Bacteriophages

Bacteriophages used in this study are listed in Table A2.2. They all belong to the family of *Myoviridae* and have genome sizes of approximately 140 kb, but show different *HhaI* restriction patterns. Phages were propagated on *C. jejuni* NCTC12662, except for phage F336 where *C. jejuni* 1447 was used (16). Stock bacteriophages were kept in SM buffer (0.05 M Tris-Cl, pH 7.5 supplemented with 5.8 g NaCl, 2.0 g MgSO₄*7H₂O and 5 ml gelatin, 2% w/v solution) at 4°C.

Table A2.2 Bacteriophages.

Strain	Category^a	<i>HhaI</i> restriction pattern^b	Origin	Reference or source
F198	III	c	Broiler intestine	(16)
F287	III	d	Duck intestine	(16)
F303	III	d	Duck abattoir	(16)
F326	III	d	Duck intestine	(16)
F336	III	b	Duck intestine	(16)

^aCategory is based on genome size (all are 140 kb)

^b*HhaI* restriction patterns as determined in (16); b, 5+2 weak bands; c, 4 bands; d, 3 bands

A2.2.3 Bacteriophage propagation

Bacteriophage propagation was performed as described by (34) using a plate lysis method developed from (11, 16). The propagating strains were grown overnight on blood agar Base II plates and harvested in BHI supplemented with 1 mM CaCl₂ and 10 mM MgSO₄ (CBHI). Bacterial suspensions were adjusted to an optical density of OD₆₀₀ = 0.35, incubated for 4 hours at 37°C under microaerobic conditions, mixed with phages at a multiplicity of infection (MOI) of 0.01 and incubated for 15 min at 37°C to allow bacteriophage adsorption. Subsequently, 0.6 ml of the adsorbed suspensions were mixed with 5 ml of NZCYM overlay agar (NZCYM (Sigma) broth with 0.6% agar) at 45°C degrees and poured onto NZCYM 1.2% agar plates. After incubation, plates with lysis were flooded with

sterile SM buffer and the phages eluted overnight with gentle shaking at 4°C.

Phage suspensions were harvested and filtered through a sterile 0.2 µm membrane filter.

A2.2.4 Bacteriophage titration

Bacteriophage titration was performed as previously described (34).

Briefly, bacterial lawns were made by mixing 5 ml NZCYM overlay agar tempered at 45°C with 0.5 ml bacteria harvested in CBHI from Base II agar plates and incubated for 4 hours as described above and poured onto NZCYM plates. Phage solutions were spotted manually with 3 times 10 µl of 10⁰ to 10⁻⁷ phage dilutions in SM buffer. Plates were incubated at 37°C for 20-24 h under microaerobic conditions and the number of plaque-forming units per ml (PFU/ml) of undiluted phage suspensions was calculated. Usually, phage titres of 10⁸ to 10⁹ pfu/ml could be obtained on both the propagating strains and *C. jejuni* MP21.

A2.2.5 Plaque assay

Susceptibility of a *C. jejuni* strain to the bacteriophages was performed using the plaque assay protocol described under Bacteriophage titration and determined as the efficiency of plaquing (EOP) in percent by dividing the PFU/ml on the test strain by the PFU/ml on the control strain (NCTC11168) multiplied by 100. The values represented are the mean count standard deviations derived from two to four independent experiments.

A2.2.6 High resolution magic angle spinning (HR-MAS) NMR spectroscopy

HR-MAS NMR analysis of intact bacterial cells was performed as previously described (24, 25).

A2.2.7 In vivo chicken experiments

One-day-old chickens were obtained from the Poultry Research Facility, Department of Agriculture, Food and Nutritional Science, University of Alberta. On the day of arrival, chickens were checked for *C. jejuni* colonization by cloacal swabs and divided in groups of 4 chickens. On day 2, chickens were first orally gavaged with either 10^7 F336 phages in SM buffer or with SM buffer alone. After approximately 30 min, the chickens were orally gavaged with a suspension containing 10^6 *C. jejuni* NCTC11168 in PBS or with PBS alone. Six days post infection, chickens were euthanized and the contents from one cecum were collected aseptically. The cecal contents were weighed and resuspended in phosphate-buffered saline at a final concentration of 0.1g per ml. This suspension was subjected to 10-fold serial dilutions and plated onto Karmali selective agar plates to determine bacterial colonization levels. One hundred microlitres of the 10^{-1} dilution was plated separately onto selective plates and all resulting bacterial colonies were pooled together. Half of this pool was used for sequencing and phage sensitivity and the other half was used for NMR analysis. The experiment was repeated twice with consistent results. PCR of gene *cj1421* was performed as previously described (Sørensen et al., 2011) while sequencing was done using the following primer: 1421-seq2-F (5'-

CTCGAGTTATAAGGATATTTTAGATGAG-3'). Gene *cj1426* was PCR-amplified using the primers: 1426-PCR-F (5'-TTGAGAATTATGATAAGATGAAGG-3') and 1426-PCR-R (5'-TTTCCTAAGAATTCTTTACTTTTCG-3') and then sequenced using the primers: 1426-seq-F (5'-AAGATCCAGATAAAAGAGATTATTTGG-3') and 1426-seq-R (5'-ATCAGGAGAATCAAAAATGATTTTTCC-3').

A2.3 Results

A2.3.1 The MeOPN moiety of the capsular polysaccharide of C. jejuni

NCTC11168 is a receptor for several phages

We recently demonstrated that phage F336 requires the *O*-methyl phosphoramidate (MeOPN) moiety attached to the Gal/Nac of the *C. jejuni* NCTC11168 CPS for infection (34). In our phage collection (16) we found that five phages, including F336, rely on capsular moieties for infection of *C. jejuni* NCTC11168, since they do not form plaques on a *kpsM* capsule mutant (Table A2.3). In our previous study, we isolated a phage F336 resistant NCTC11168 variant *in vitro* (11168R), which lost the MeOPN attached to the Gal/Nac residue due to the presence of an additional G in gene *cj1421* resulting in a phased-off version of this gene (34). Here we found that 11168R had gained cross-resistance to all of the four phages: F198, F287, F303 and F326 (Table A2.3). While phages F198 and F303 did not form plaques on *C. jejuni* 11168R at all, plaques were observed with F287 and F326, but with a much lower efficiency of plaquing (EOP) compared to wild type NCTC11168. Hence, the MeOPN structure is

important for infection by the four other phages, although two of these phages (F287 and F326) were able to infect a strain not expressing the MeOPN modification. Similar results were obtained when screening a *cj1421* MeOPN transferase deletion mutant in the NCTC11168 wild type background (data not shown). Supporting this, the EOP of four of these phages, including F336, were fully restored to wild type NCTC11168 levels, while the EOP of phage F326 was partially restored, when we tested the phages against a 11168R revertant containing an intact *cj1421* gene and returned expression of the CPS MeOPN (*C. jejuni* S11168R; Sørensen et al., 2011) (Table A2.3). Thus, several phages rely on the MeOPN moiety attached to the GalNAc residue of CPS for infection of *C. jejuni* NCTC11168.

Table A2.3 Efficiency of plaquing (EOP) of phages related to F336 as compared to NCTC11168

Phage	NCTC11168	11168R	S11168R	<i>kpsM</i>
F198	100 ^a	— ^b	85.2±24.7	—
F287	100	0.04±0.03	2300±282.8	—
F303	100	—	350±113.1	—
F326	100	0.02±0.02	11.6±6.7	—
F336	100	—	331.8±64.3	—

^aEOP is calculated in percent as the PFU/ml of the phages on the test strain

divided by the PFU/ml obtained on NCTC11168 multiplied by 100

^b—No plaques formed

A2.3.2 The location of the MeOPN on the CPS is important for phage infection

The MeOPN moiety of *C. jejuni* NCTC11168 can be attached to the GalfNAc and the Hep residues in the CPS (25) and we speculated that the attachment site of MeOPN may be important for phage infection. We therefore conducted plaque assays and determined EOPs of the five phages F198, F287, F303, F326 and F336 on the hypermotile NCTC11168 variant 11168H as well as on defined mutants in the *cj1421* and *cj1422* MeOPN transferase genes in this background and compared to the NCTC11168 wild type strain. All of these strains have previously been characterized by HR-MAS NMR and ^1H - ^{31}P heteronuclear single-quantum correlation (HSQC) HR-MAS NMR for the presence/absence of MeOPN in their CPS structure (25). Our results showed that the attachment site of MeOPN in the CPS clearly influenced the efficiency of the phages to infect a particular strain (Figure A2.1). In general, all phages showed a higher EOP when MeOPN was situated on the GalfNAc residue (Figure A2.1A and A2.1E) as compared to MeOPN attached to the Hep residue in the CPS (Figure A2.1C). A lower EOP obtained with MeOPN attached to the Hep residue was further confirmed by screening a *cj1421+cj1422* deletion strain complemented with *cj1422* (25) with our five phages (Figure A2.1F). Interestingly, the four phages F198, F287, F303 and F336 were not able to infect *C. jejuni* 11168H, which is the only strain expressing MeOPN on both GalfNAc and Hep (Figure A2.1B), suggesting that two MeOPN moieties may inhibit phage infection. Finally, we observed that the presence of two other phase variable CPS

modifications, the 3-O-Me and 6-O-Me groups influenced the plaquing efficiency of the phages. We also isolated a 11168H single colony variant (11168H1) that by HR-MAS NMR and ^1H - ^{31}P HSQC HR-MAS NMR analysis showed the same CPS profile as the NCTC11168 wild type strain (data not shown). The phage sensitivity profile observed with this strain (Figure A2.1G) confirmed the results obtained with NCTC11168 (Figure A2.1A). Thus, the presence of the 6-O-Me group on the CPS reduced the plaquing efficiencies of phages F287 and F326 (Figure A2.1A and E), suggesting that other phase variable CPS modifications besides MeOPN affect phage infection.

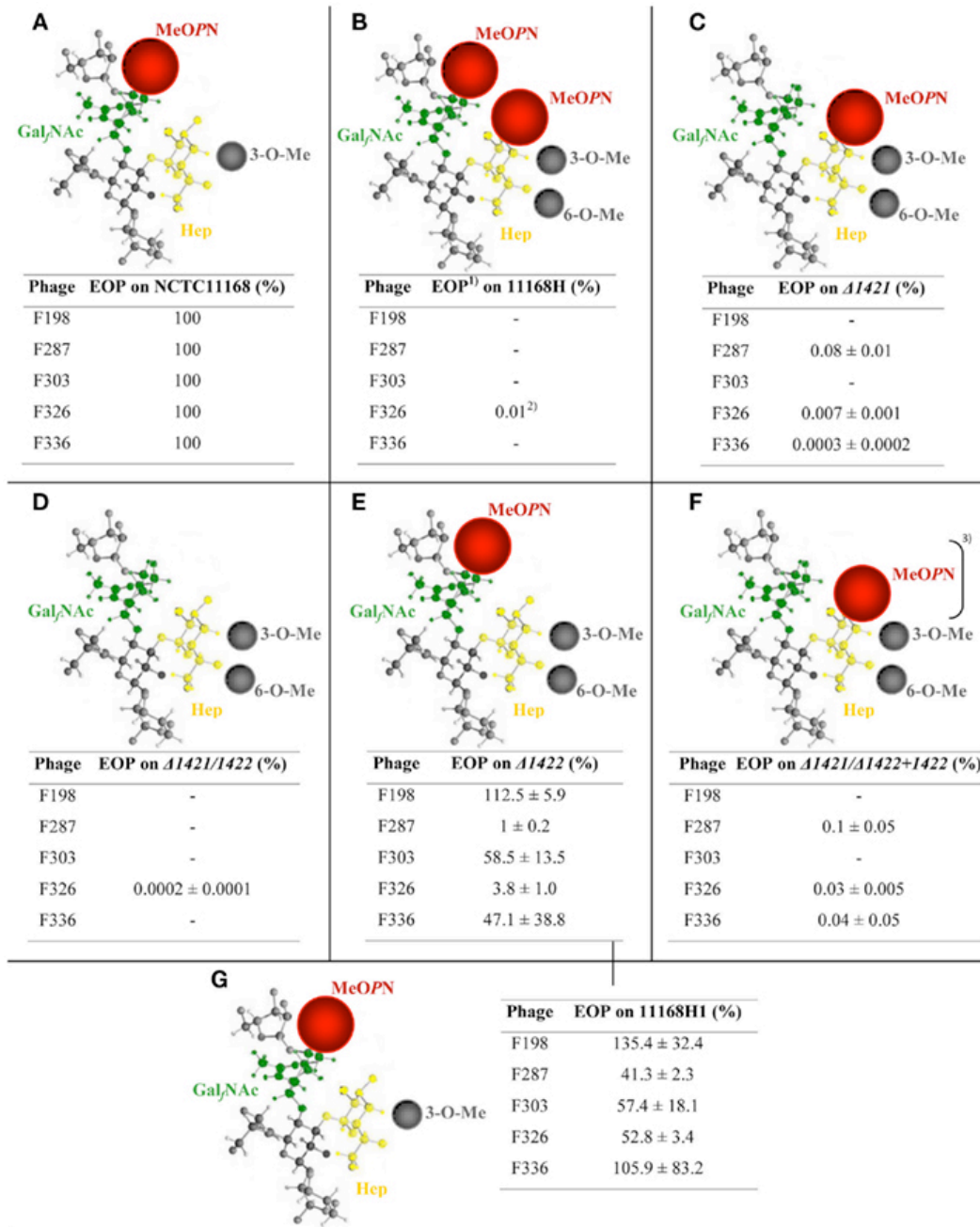

Figure A2.1 CPS structures expressed by defined MeOPN transferase mutants and their affect on phage sensitivity. The CPS structure is schematically illustrated (modified from Guerry and Szymanski, 2008). Phage sensitivity patterns are calculated as the ¹efficiency of plaquing (EOP) as compared to plaque

formation on the NCTC11168 wild type strain. A. NCTC11168; B. 11168H; C. 11168H Δ 1421; D. 11168H Δ 1421/ Δ 1422; E. 11168H Δ 1422; F. 11168H Δ 1421/ Δ 1422+1422; and G. 11168H1. ²Plaques were only detected in one out of three experiments. ³MeOPN detected in lower amounts due to partial complementation. Abbreviations are: GalfNAc: N-acetylgalactosamine in the furanose configuration; MeOPN: *O*-methyl phosphoramidate; Hep: heptose; and O-Me: *O*-methyl.

A2.3.3 C. jejuni phages require different combinations of phase variable CPS modifications for successful infection

Phase variable expression of the capsular modifications in *C. jejuni* NCTC11168 is well documented (29, 35, 37). Three frozen stocks of NCTC11168 (MP24, MP25 and MP26) that had been passaged a number of times in our laboratory were analyzed by HR-MAS NMR and ¹H-³¹P HSQC HR-MAS NMR (Figure A2.2). This analysis revealed differences in the four phase variable modifications of the CPS structure i.e. the 3-*O*-Me, 6-*O*-Me, MeOPN-GalfNAc and MeOPN-Hep as compared to our NCTC11168 wild type (Table A2.4). We also included another NCTC11168 variant (V26) previously shown to have yet another different set of modifications (4, 35).

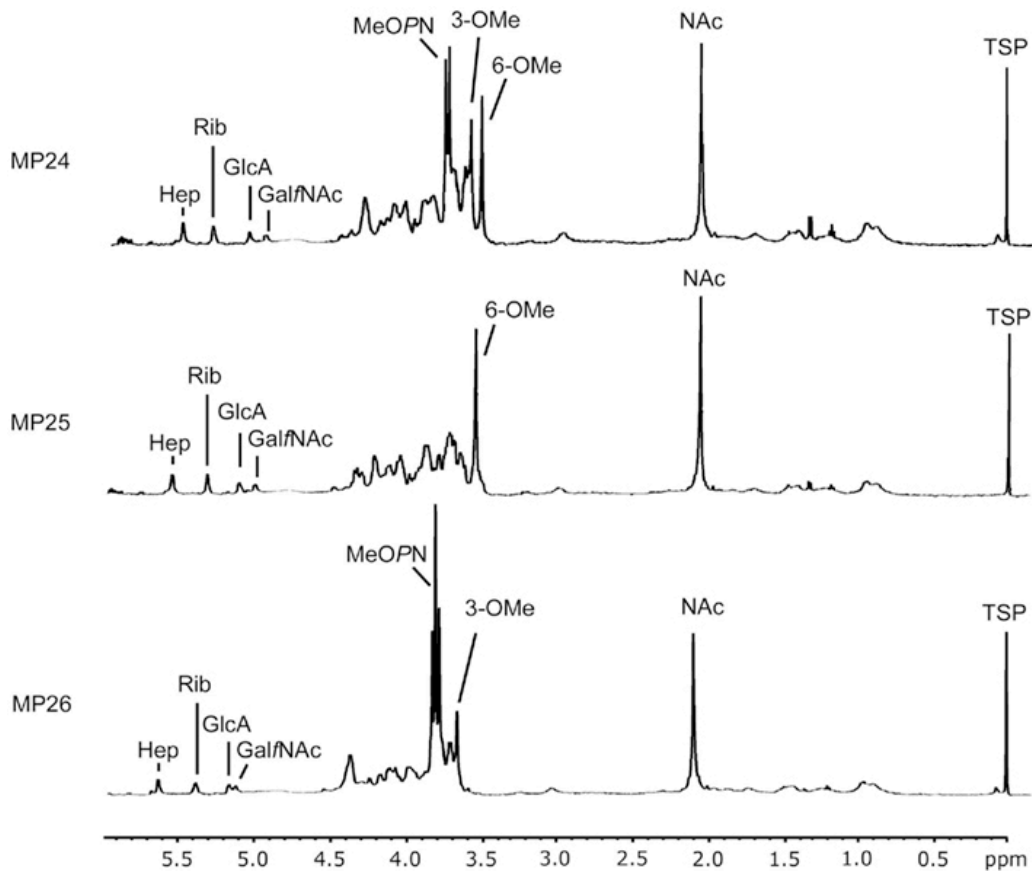

Figure A2.2 HR-MAS NMR spectra showing the differences in CPS modifications between NCTC11168 variants MP24, MP25 and MP26. ^1H CPMG spectra of intact *C. jejuni* cells. Abbreviations are: Hep: *D*-glycero- α -L-gluco-Hep; Rib: β -D-Ribf; GlcA: α -D-GlcpA6(*NGro*); GalfNAc: β -D-GalfNAc; MeOPN: *O*-methyl phosphoramidate; OMe: *O*-methyl; NAc: *N*-acetyl; TSP: trimethylsilylpropionic acid standard.

Table A2.4 ppm values for ¹H-HR-MAS NMR spectra for NCTC11168 variants and MeOPN transferase status

<i>C. jejuni</i> strain	Hep ^a	Rib	GlcA	GalfNAc	3-O-Me	6-O-Me	Nac	MeOPN	<i>cj1421/cj1422</i> (GalfNAc/Hep) ^b
NCTC11168 MP24	5.582	5.376	5.103	5.015	3.629	3.557	2.071	3.772	—/+
NCTC11168 MP25	5.599	5.363	5.148	5.039	—	3.569	2.066	— ^c	—/—
NCTC11168 MP26	5.610	5.361	5.143	5.101	3.630	—	2.068	3.768 /3.743	+/+

^aOnly anomeric proton resonances for carbohydrate residues are listed

^bSummary of sequencing results indicating the “on” (+) and “off” (-) status of the genes encoding the MeOPN transferases onto GalfNAc (*cj1421*) and Hep (*cj1422*)

^cOnly trace amounts of MeOPN detected.

Plaque assays using our five phages showed that these *C. jejuni* strains had distinct phage sensitivity profiles (Figure A2.3B-E). Interestingly, *C. jejuni* MP26 that expresses both MeOPN moieties, similar to the phage resistant *C. jejuni* 11168H (Figure A2.1B), could be infected by four of the five phages although with different efficiencies (Figure A2.3D). However, CPS of *C. jejuni* MP26 only contains the 3-O-Me group, whereas 11168H CPS contains both the 3-O-Me and 6-O-Me groups (Figure A2.1B and A2.3D). These results indicate that the presence of 6-O-Me may inhibit phage infection. This was further supported by the observation that none of the phages formed plaques when the 3-O-Me was exchanged with the 6-O-Me while retaining the MeOPN modification attached to GalfNAc (Figure A2.3A and E). Furthermore, the presence of the 6-O-Me group in combination with a MeOPN situated on the GalfNAc and a 3-O-Me group

clearly inhibited infection by phage F287 and F326 (Figure A2.1E and 1G). Thus, our data suggest that the 6-O-Me group inhibits plaque formation *in vitro* and that all five phages require MeOPN attached to Gal/NAc together with the 3-O-Me to obtain the most efficient infection. However, different combinations of the phase variable CPS modifications appear to influence binding of the phages differently. In particular, phage F326 showed the lowest EOP values (Table A2.3 and Figures A2.1 and A2.3) suggesting that other combinations of receptors, not investigated in this study, might be optimal for the binding of this phage.

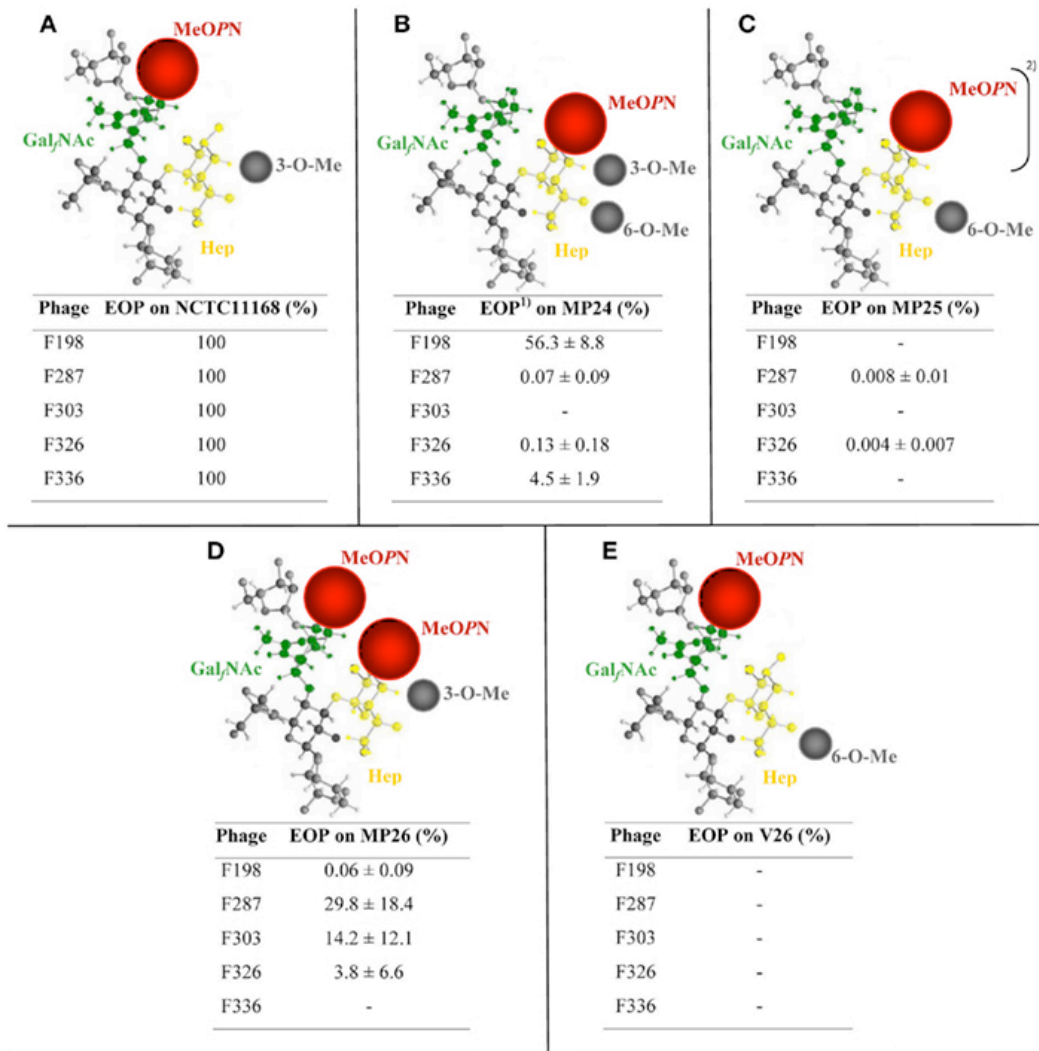

Figure A2.3 CPS structures expressed by NCTC11168 variants and the corresponding phage sensitivity profiles. The CPS structure is schematically illustrated (modified from Gurry and Szymanski, 2008). Phage sensitivity patterns are calculated as the ¹efficiency of plaquing (EOP) as compared to plaque formation on the NCTC11168 wild type strain. A. NCTC11168; B. NCTC11168 MP24; C. NCTC11168 MP25; D. NCTC11168 MP26; and E. NCTC11168 V26. ²MeOPN only detected in minor amounts. Abbreviations as above are: Gal7NAc:

N-acetylgalactosamine in the furanose configuration; MeOPN: *O*-methyl phosphoramidate; Hep: heptose; and O-Me: *O*-methyl.

A2.3.4 Selection for phage resistant variants during C. jejuni colonization of chickens

To assess whether *C. jejuni* is capable of becoming resistant to bacteriophage F336 *in vivo* during colonization of chickens, we orally gavaged two-day-old chickens with F336 and subsequently with *C. jejuni* NCTC11168. After 6 days, the chickens were euthanized and the bacteria from the ceca were analyzed. We observed similar levels of colonization after 6 days of infection between the groups receiving bacteria only, as compared to those receiving bacteria and bacteriophages (ie 10^9 CFU/g cecal content, Table A2.5). The bacteria grown from the cecal contents were directly pooled from plates and analyzed by HR-MAS NMR. All bacteria obtained from chickens infected with *C. jejuni* alone showed an NMR profile that was the same as the NMR spectrum of the inoculum: The bacteria expressed one MeOPN attached to Gal/NAc and the 3-O-Me group bound to Hep. However, bacteria from the group of chickens that received both bacteria and bacteriophages had lost the MeOPN in all instances, except for one (Figure A2.4 and Table A2.5). In chicken #238, infected with phage F336 and *C. jejuni*, the bacteria showed reduced levels of MeOPN present on both Gal/NAc and Hep, but the bacteria also expressed high levels of 6-O-Me on the Hep (Figure A2.4).

Table A2.5 Presence of MeOPN and phage sensitivity of *C. jejuni* isolated after colonization of chickens.

Chicken	Infected with	Bacterial counts (CFU/g)	MeOPN on Gal/NAc	Phage sensitivity ^a
MP21 Inoculum	NR	NR	+	Yes
MP21 Karmali	NR	NR	+	Yes
Chicken 405	MP21	5.7 x 10 ⁹	+	Yes
Chicken 406	MP21	4.1 x 10 ⁹	+	Yes
Chicken 407	MP21	9.9 x 10 ⁹	+	Yes
Chicken 408	MP21	1.1 x 10 ⁹	+	Yes
Chicken 505	MP21 + F336	7.9 x 10 ⁹	—	No
Chicken 506	MP21 + F336	5.0 x 10 ⁹	—	No
Chicken 507	MP21 + F336	5.8 x 10 ⁹	—	No
Chicken 508	MP21 + F336	8.5 x 10 ⁹	—	No
Chicken 343	MP21	2.0 x 10 ⁹	+	Yes
Chicken 344	MP21	2.1 x 10 ⁹	+	Yes
Chicken 345	MP21	1.6 x 10 ⁹	+	Yes
Chicken 346	MP21	3.6 x 10 ⁹	+	Yes
Chicken 237	MP21 + F336	1.2 x 10 ⁹	—	No
Chicken 238	MP21 + F336	5.5 x 10 ⁹	+ ^b	No
Chicken 239	MP21 + F336	4.7 x 10 ⁹	— ^c	No
Chicken 240	MP21 + F336	4.1 x 10 ⁹	—	No

Chicks 405-408 and 505-508 are from the first experiment, while chicks 343-346 and 237-240 are from the second experiment. NR, not relevant.

^aYes, plaques formed on isolated strain; No, no plaques formed on isolated strain.

^bBacteria isolated from this chick showed reduced MeOPN levels (of both MeOPN groups) and enhanced levels of 6-*O*-Me.

¹³CMeOPN levels barely above the baseline could be detected from bacteria isolated from this chick.

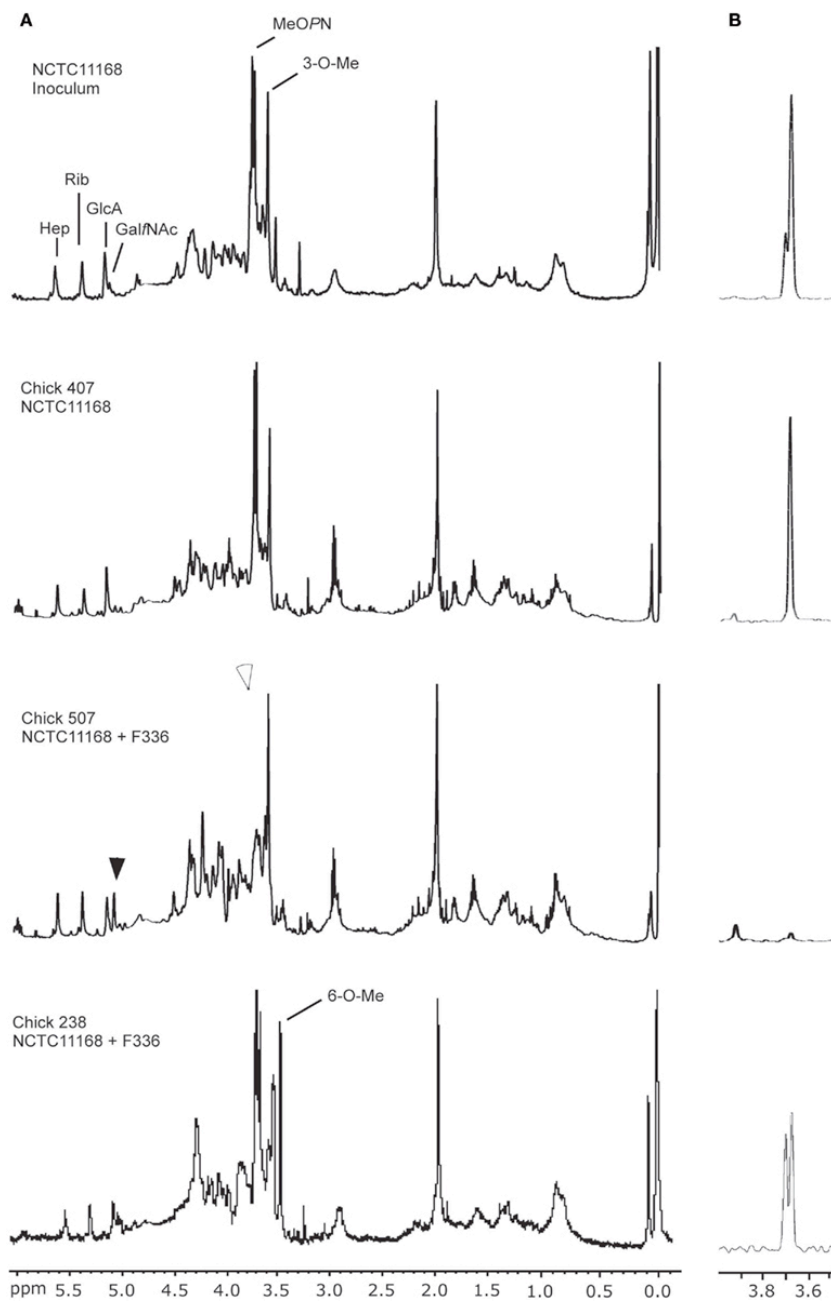

Figure A2.4 NMR analysis of intact *C. jejuni* cells recovered from chicken cecal contents. (A) ¹H HR-MAS NMR CPMG spectra, displaying the capsular profile

and (B) corresponding 1D ^1H - ^{31}P HSQC spectra specifically demonstrating the phosphoramidate resonances. Black arrowhead: note the change in the GalfNAc resonance due to the absence of MeOPN. White arrowhead: note the absence of the MeOPN specific resonance.

To test whether the observed changes in CPS modifications resulted in phage resistance, we performed bacterial titration assays with all of the isolates recovered from the chickens. All isolates from the F336 infected birds had gained resistance to phage F336 and still showed similar levels of colonization (Table A2.5). Previously, we have shown that a loss of MeOPN on GalfNAc can be the result of a switch in the polyG region of the MeOPN transferase gene *cj1421* (34). To determine whether the loss of MeOPN and subsequent phage resistance were the result of a switch in the polyG region, we sequenced gene *cj1421* from the pooled colonies from both experiments. All phage-sensitive isolates showed 9 G residues in the polyG region, while all phage-resistant isolates (except from chick 238) showed either 8 or 10 G residues in this region, which in both cases results in a non-functional transferase, due to a premature stop codon 1 or 5 amino acids after the polyG region, respectively (data not shown). Examination of the pooled colonies from chick 238 showed 9 G residues in the polyG region of *cj1421*, consistent with the observed MeOPN expression. However, sequencing of the polyG region of *cj1426* from the pooled colonies from chick 238 showed 10 G residues indicating that the 6-O-Me transferase enzyme was functional (again

consistent with the acquired expression of the Me modification in Fig. 4) compared to 11 G residues in the parental strain lacking this modification. Thus, *C. jejuni* can become resistant to phage F336 during *in vivo* colonization of chickens by changing the expression of its CPS phase variable modifications.

A2.4 Discussion

Implementation of efficient phage therapies to target pathogenic bacteria requires detailed knowledge of the bacterial receptors recognized by the phages, as this bacteria-phage interaction is the first event in a process leading to lysis of the host organism. We previously identified the *C. jejuni* NCTC11168 CPS phase variable MeOPN modification as the receptor for phage F336 (34). The goal of the present study was to further explore the role of MeOPN and other *C. jejuni* phase variable CPS modifications, such as O-methylation in phage infection. We compared five different phages, including F336 that were unable to proliferate in an acapsular mutant of *C. jejuni* NCTC11168, and determined their ability to infect NCTC11168 variants containing the same CPS backbone sugars as NCTC11168, but with different modifications.

We found that the phages F198, F287, F303, F326 and F336 all infected *C. jejuni* most efficiently when the 3-O-Me modification on Hep and a MeOPN moiety was present, with higher EOPs observed when the MeOPN modification was attached to Gal/NAc rather than Hep. Interestingly, when the 3-O-Me was exchanged with the 6-O-Me while retaining the MeOPN on Gal/NAc, none of the phages formed plaques at all, demonstrating a clear role for the O-methyl Hep

modifications for phage infection, in addition to the previously identified phage receptor, MeOPN (34). By looking at the predicted three dimensional (3D) structure of the *C. jejuni* NCTC11168 CPS (15), it is possible that the presence or absence of one or more CPS modifications may lead to conformational changes that interfere with the phage binding process. Indeed it has been found that changes in the 3D conformation of the outer membrane protein OmpA, which serves as the receptor for many of the T-even phages infecting *E. coli*, leads to phage resistance (31). Furthermore, the spatial arrangement of the modifications may be important for phage recognition and some modifications may potentially block the phage binding site when they are expressed. Certainly masking the phage binding site is a well known resistance mechanism in other bacteria. One example is *Staphylococcus aureus* that masks its phage receptor with protein A, a cell-wall-anchored virulence factor for this bacterium (28). In agreement with this hypothesis, we observed that when MeOPN was present on both the Gal/NAc and Hep residues together with the 3-O-Me and 6-O-Me Hep modifications, then four of the five phages could no longer infect that particular *C. jejuni* 11168 strain. Thus, both the presence and absence of the capsular modifications appears to modulate phage infectivity of the NCTC1168 strain.

Our results demonstrate that the phages infecting *C. jejuni* are highly specific in the recognition of the capsular polysaccharides and that each phage has evolved to recognize a particular combination of capsular modifications. One might speculate that the phages included in this study originated from the same

ancestral phage that has co-evolved with *C. jejuni* to recognize different capsular surface structures by minor modifications in the phage receptor binding proteins (RBP). In support of this, sequencing of viral proteins from the *C. jejuni* phage CP220 revealed at least two distinct tail structures in the mature virions although propagated from a single plaque (38), suggesting a possibility for the phage to recognize multiple receptors. A similar phenomena has been observed for capsular phages infecting *E. coli* (33). Indeed RBPs of other phages often have hypervariable regions in the receptor recognizing domains, reflecting the ability of the phage to easily accumulate mutations thereby changing the structure of the RBP to recognize modified receptors or new types of receptors, such as switching from protein to carbohydrate recognition (10, 17, 26). The *C. jejuni* phages investigated in this study have similar genome sizes and morphologies and were previously isolated from duck and broiler intestines and duck abattoirs (16). Although these phages all are able to infect the NCTC1168 strain, they do show different host ranges for *C. jejuni* strains of different Penner serotypes (16). In addition, enzymatic restriction cleavage of the phage genomes revealed differences among the phages (Table A2.2, (16)). Thus, although a conserved head and tail architecture is maintained, it is apparent that genomic dissimilarities exist between the five phages compared in this study and this may account for the differences in host specificity.

In *C. jejuni*, the capsular polysaccharides are highly diverse, due to differences in the genetic compositions of the CPS loci, but also because many of

the genes in these loci contain homopolymeric tracts making them prone to phase variation (5, 19, 22, 24, 35, 37). Based on the number of phase variable modifications in the capsule of *C. jejuni* NCTC11168 alone, this may result in the expression of >700 CPS structural variants. Our results demonstrate that phase variable CPS surface structures clearly influence the phage attachment sites in *C. jejuni* NCTC11168. Phase variable expression also affects phage adsorption in *Bordetella* spp. These bacteria use phase variable expression of the BvgAS two-component regulatory system to alter their surfaces through the regulation of colonization and virulence factors and also expression of the phage BPP-1 receptor Prn (pertactin autotransporter) (23). To combat these changes, the BPP-1 phage has a sophisticated mechanism of varying its RBP ($\sim 10^{+13}$ possible sequences) that approaches the levels of diversity observed for immunoglobulins (9, 23), and the phage is thus able to overcome the resistance by an equally efficient mechanism.

It was previously shown that CPS expression is important for *C. jejuni* colonization of the chicken gut as well as being important for interactions with human models of disease (1, 18). Here we show for the first time that the presence of phages selects for specific CPS variants *in vivo* in the chicken gut without altering the colonization levels, even though MeOPN expression influences *C. jejuni* invasion of human cells (van Alphen, personal communication). Thus, the roles of phase-variable CPS modifications, such as the MeOPN and the O-methyl groups, may not only be linked to adaptation to the human or chicken hosts, but

may serve an important function for *C. jejuni* survival in the avian gut; an environment that contains a high number of bacteria as well as phages (7, 16). Here, we have shown that phase variable modifications of the capsular polysaccharides influence phage infectivity, suggesting that the constant exposure of *C. jejuni* to phages in the avian gut selects for changes in the phase variable structures of the CPS leading to a continuing co-evolution of *C. jejuni* receptors and phage RBPs. This should be considered when developing future strategies for phage therapy against *C. jejuni* in the chicken host and when determining the kinetics of resistance development and the timing for therapy administration. Since the alteration of bacterial surface receptors that reduces or eliminates phage adsorption to the host cell appears to be the most common mechanism of phage resistance (2), continued investigations into the diversity of phage receptors in *C. jejuni* is required to select the most efficient combinations of phages for therapy.

A2.5 Acknowledgements

We are grateful to B. Wren for the gift of the *C. jejuni* NCTC11168 *kpsM* mutant. We sincerely appreciate the expert technical assistance of Lisbeth Schade Hansen, Christel Galschiøt Buerholt, Mark Miskolzie, David Simpson, Yasmin Barre, Cory Wenzel, Abofu Alemka, and Denis Arutyunov. This work was funded by a grant from the FOOD Research School at the Faculty of Life Sciences, University of Copenhagen, Denmark. Lieke B. van Alphen holds an Alberta Innovates Health Solutions (AIHS) Postdoctoral Fellowship, Shauna M.

Crowley holds an AIHS Graduate Scholarship and Christine M. Szymanski holds an Alberta Innovates Scholar Award.

A2.6 Literature cited

1. **Bacon DJ, Szymanski CM, Burr DH, Silver RP, Alm RA, Guerry P.** 2001. A phase-variable capsule is involved in virulence of *Campylobacter jejuni* 81-176. *Mol. Microbiol.* **40**:769-777.
2. **Bohannon BJM, Lenski RE.** 2000. Linking genetic change to community evolution: Insights from studies of bacteria and bacteriophage. *Ecology Letters.* **3**:362-377.
3. **Brussow H, Hendrix RW.** 2002. Phage genomics: Small is beautiful. *Cell.* **108**:13-16.
4. **Carrillo CD, Taboada E, Nash JH, Lanthier P, Kelly J, Lau PC, Verhulp R, Mykytczuk O, Sy J, Findlay WA, Amoako K, Gomis S, Willson P, Austin JW, Potter A, Babiuk L, Allan B, Szymanski CM.** 2004. Genome-wide expression analyses of *Campylobacter jejuni* NCTC11168 reveals coordinate regulation of motility and virulence by *flhA*. *J. Biol. Chem.* **279**:20327-20338.
5. **Chen YH, Poly F, Pakulski Z, Guerry P, Monteiro MA.** 2008. The chemical structure and genetic locus of *Campylobacter jejuni* CG8486 (serotype HS:4) capsular polysaccharide: the identification of 6-deoxy-D-ido-heptopyranose. *Carbohydr. Res.* **343**:1034-1040.
6. **Comstock LE, Kasper DL.** 2006. Bacterial glycans: Key mediators of diverse host immune responses. *Cell.* **126**:847-850.
7. **Connerton PL, Loc Carrillo CM, Swift C, Dillon E, Scott A, Rees CE, Dodd CE, Frost J, Connerton IF.** 2004. Longitudinal study of *Campylobacter jejuni* bacteriophages and their hosts from broiler chickens. *Appl. Environ. Microbiol.* **70**:3877-3883.
8. **Coward C, Grant AJ, Swift C, Philp J, Towler R, Heydarian M, Frost JA, Maskell DJ.** 2006. Phase-variable surface structures are required for infection of *Campylobacter jejuni* by bacteriophages. *Appl. Environ. Microbiol.* **72**:4638-4647.
9. **Doulatov S, Hodes A, Dai L, Mandhana N, Liu M, Deora R, Simons RW, Zimmerly S, Miller JF.** 2004. Tropism switching in *Bordetella* bacteriophage defines a family of diversity-generating retroelements. *Nature.* **431**:476-481. d
10. **Drexler K, Dannull J, Hindennach I, Mutschler B, Henning U.** 1991. Single mutations in a gene for a tail fiber component of an *Escherichia coli* phage

can cause an extension from a protein to a carbohydrate as a receptor. *J. Mol. Biol.* **219**:655-663.

11. **Frost JA, Kramer JM, Gillanders SA.** 1999. Phage typing of *Campylobacter jejuni* and *Campylobacter coli* and its use as an adjunct to serotyping. *Epidemiol. Infect.* **123**:47-55.
12. **Gemski P, Koeltzow DE, Formal SB.** 1975. Phage conversion of *Shigella flexneri* group antigens. *Infect. Immun.* **11**:685-691.
13. **Gemski P, Stocker BA.** 1967. Transduction by bacteriophage P22 in nonsmooth mutants of *Salmonella typhimurium*. *J. Bacteriol.* **93**:1588-1597.
14. **Guerry P, Poly F, Riddle M, Maue AC, Chen Y, Monteiro MA.** 2012. *Campylobacter* polysaccharide capsules: virulence and vaccines. *Front. Cell. Inf. Microbio.* **2**:7.
15. **Guerry P, Szymanski CM.** 2008. *Campylobacter* sugars sticking out. *Trends Microbiol.* **16**:428-435.
16. **Hansen VM, Rosenquist H, Baggesen DL, Brown S, Christensen BB.** 2007. Characterization of *Campylobacter* phages including analysis of host range by selected *Campylobacter* Penner serotypes. *BMC Microbiol.* **7**:90.
17. **Hashemolhosseini S, Montag D, Kramer L, Henning U.** 1994. Determinants of receptor specificity of coliphages of the T4 family. A chaperone alters the host range. *J. Mol. Biol.* **241**:524-533.
18. **Jones MA, Marston KL, Woodall CA, Maskell DJ, Linton D, Karlyshev AV, Dorrell N, Wren BW, Barrow PA.** 2004. Adaptation of *Campylobacter jejuni* NCTC11168 to high-level colonization of the avian gastrointestinal tract. *Infect. Immun.* **72**:3769-3776.
19. **Karlyshev AV, Champion OL, Churcher C, Brisson JR, Jarrell HC, Gilbert M, Brochu D, St Michael F, Li J, Wakarchuk WW, Goodhead I, Sanders M, Stevens K, White B, Parkhill J, Wren BW, Szymanski CM.** 2005. Analysis of *Campylobacter jejuni* capsular loci reveals multiple mechanisms for the generation of structural diversity and the ability to form complex heptoses. *Mol. Microbiol.* **55**:90-103.
20. **Kutateladze M, Adamia R.** 2010. Bacteriophages as potential new therapeutics to replace or supplement antibiotics. *Trends Biotechnol.* **28**:591-595.

21. **Levy SB, Marshall B.** 2004. Antibacterial resistance worldwide: Causes, challenges and responses. *Nat. Med.* **10**:S122-9.
22. **Linton D, Karlyshev AV, Wren BW.** 2001. Deciphering *Campylobacter jejuni* cell surface interactions from the genome sequence. *Curr. Opin. Microbiol.* **4**:35-40.
23. **Liu M, Deora R, Doulatov SR, Gingery M, Eiserling FA, Preston A, Maskell DJ, Simons RW, Cotter PA, Parkhill J, Miller JF.** 2002. Reverse transcriptase-mediated tropism switching in *Bordetella* bacteriophage. *Science.* **295**:2091-2094.
24. **McNally DJ, Jarrell HC, Li J, Khieu NH, Vinogradov E, Szymanski CM, Brisson JR.** 2005. The HS:1 serostrain of *Campylobacter jejuni* has a complex teichoic acid-like capsular polysaccharide with nonstoichiometric fructofuranose branches and *O*-methyl phosphoramidate groups. *FEBS J.* **272**:4407-4422.
25. **McNally DJ, Lamoureux MP, Karlyshev AV, Fiori LM, Li J, Thacker G, Coleman RA, Khieu NH, Wren BW, Brisson JR, Jarrell HC, Szymanski CM.** 2007. Commonality and biosynthesis of the *O*-methyl phosphoramidate capsule modification in *Campylobacter jejuni*. *J. Biol. Chem.* **282**:28566-28576.
26. **Montag D, Hashemolhosseini S, Henning U.** 1990. Receptor-recognizing proteins of T-even type bacteriophages. The receptor-recognizing area of proteins 37 of phages T4 Tula and Tu1b. *J. Mol. Biol.* **216**:327-334.
27. **Morona R, Klose M, Henning U.** 1984. *Escherichia coli* K-12 outer membrane protein (OmpA) as a bacteriophage receptor: Analysis of mutant genes expressing altered proteins. *J. Bacteriol.* **159**:570-578.
28. **Nordstrom K, Forsgren A.** 1974. Effect of protein A on adsorption of bacteriophages to *Staphylococcus aureus*. *J. Virol.* **14**:198-202.
29. **Parkhill J, Wren BW, Mungall K, Ketley JM, Churcher C, Basham D, Chillingworth T, Davies RM, Feltwell T, Holroyd S, Jagels K, Karlyshev AV, Moule S, Pallen MJ, Penn CW, Quail MA, Rajandream MA, Rutherford KM, van Vliet AH, Whitehead S, Barrell BG.** 2000. The genome sequence of the food-borne pathogen *Campylobacter jejuni* reveals hypervariable sequences. *Nature.* **403**:665-668.
30. **Rakhuba DV, Kolomiets EI, Dey ES, Novik GI.** 2010. Bacteriophage receptors, mechanisms of phage adsorption and penetration into host cell. *Pol. J. Microbiol.* **59**:145-155.

31. **Riede I, Eschbach ML.** 1986. Evidence that TraT interacts with OmpA of *Escherichia coli*. FEBS Lett. **205**:241-245.
32. **Roberts IS.** 1996. The biochemistry and genetics of capsular polysaccharide production in bacteria. Annu. Rev. Microbiol. **50**:285-315.
33. **Scholl D, Rogers S, Adhya S, Merrill CR.** 2001. Bacteriophage K1-5 encodes two different tail fiber proteins, allowing it to infect and replicate on both K1 and K5 strains of *Escherichia coli*. J. Virol. **75**:2509-2515.
34. **Sørensen MC, van Alphen LB, Harboe A, Li J, Christensen BB, Szymanski CM, Brøndsted L.** 2011. Bacteriophage F336 recognizes the capsular phosphoramidate modification of *Campylobacter jejuni* NCTC11168. J. Bacteriol. **193**:6742-6749.
35. **St. Michael F, Szymanski CM, Li J, Chan KH, Khieu NH, Larocque S, Wakarchuk WW, Brisson JR, Monteiro MA.** 2002. The structures of the lipooligosaccharide and capsule polysaccharide of *Campylobacter jejuni* genome sequenced strain NCTC 11168. Eur. J. Biochem. **269**:5119-5136.
36. **Stirm S, Freund-Molbert E.** 1971. *Escherichia coli* capsule bacteriophages. II. Morphology. J. Virol. **8**:330-342.
37. **Szymanski CM, Michael FS, Jarrell HC, Li J, Gilbert M, Larocque S, Vinogradov E, Brisson JR.** 2003. Detection of conserved N-linked glycans and phase-variable lipooligosaccharides and capsules from *Campylobacter* cells by mass spectrometry and high resolution magic angle spinning NMR spectroscopy. J. Biol. Chem. **278**:24509-24520.
38. **Timms AR, Cambray-Young J, Scott AE, Petty NK, Connerton PL, Clarke L, Seeger K, Quail M, Cummings N, Maskell DJ, Thomson NR, Connerton IF.** 2010. Evidence for a lineage of virulent bacteriophages that target *Campylobacter*. BMC Genomics. **11**:214.
39. **Weinbauer MG.** 2004. Ecology of prokaryotic viruses. FEMS Microbiol. Rev. **28**:127-181.
40. **Yu F, Mizushima S.** 1982. Roles of lipopolysaccharide and outer membrane protein OmpC of *Escherichia coli* K-12 in the receptor function for bacteriophage T4. J. Bacteriol. **151**:718-722.