

34311



National Library of Canada

Bibliothèque nationale du Canada

CANADIAN THESES ON MICROFICHE

THÈSES CANADIENNES SUR MICROFICHE

NAME OF AUTHOR/NOM DE L'AUTEUR Mary MacCrimmon Chance

TITLE OF THESIS/TITRE DE LA THÈSE Influence of water flow and particle concentration on larvae of the black fly *Simulium vittatum* Zell. (Diptera: Simuliidae), with emphasis on larval filter-feeding.

UNIVERSITY/UNIVERSITÉ of Alberta

DEGREE FOR WHICH THESIS WAS PRESENTED/ GRADE POUR LEQUEL CETTE THÈSE FUT PRÉSENTÉE Ph.D

YEAR THIS DEGREE CONFERRED/ANNÉE D'OBTENTION DE CE GRADE 1977

NAME OF SUPERVISOR/NOM DU DIRECTEUR DE THÈSE Dr. D. A. Craig

Permission is hereby granted to the NATIONAL LIBRARY OF CANADA to microfilm this thesis and to lend or sell copies of the film.

The author reserves other publication rights, and neither the thesis nor extensive extracts from it may be printed or otherwise reproduced without the author's written permission.

L'autorisation est, par la présente, accordée à la BIBLIOTHÈQUE NATIONALE DU CANADA de microfilmer cette thèse et de prêter ou de vendre des exemplaires du film.

L'auteur se réserve les autres droits de publication; ni la thèse ni de longs extraits de celle-ci ne doivent être imprimés ou autrement reproduits sans l'autorisation écrite de l'auteur.

DATED/DATE August 30, 1977 SIGNED/SIGNÉ Mary M. Chance

PERMANENT ADDRESS/RÉSIDENCE FIXE 4755 Arthur Avenue
Dollard de Ormeaux
Quebec, H9G 2M2



National Library of Canada

Cataloguing Branch
Canadian Theses Division

Ottawa, Canada
K1A 0N4

Bibliothèque nationale du Canada

Direction du catalogage
Division des thèses canadiennes

NOTICE

The quality of this microfiche is heavily dependent upon the quality of the original thesis submitted for microfilming. Every effort has been made to ensure the highest quality of reproduction possible.

If pages are missing, contact the university which granted the degree.

Some pages may have indistinct print especially if the original pages were typed with a poor typewriter ribbon or if the university sent us a poor photocopy.

Previously copyrighted materials (journal articles, published tests, etc.) are not filmed.

Reproduction in full or in part of this film is governed by the Canadian Copyright Act, R.S.C. 1970, c. C-30. Please read the authorization forms which accompany this thesis.

**THIS DISSERTATION
HAS BEEN MICROFILMED
EXACTLY AS RECEIVED**

AVIS

La qualité de cette microfiche dépend grandement de la qualité de la thèse soumise au microfilmage. Nous avons tout fait pour assurer une qualité supérieure de reproduction.

S'il manque des pages, veuillez communiquer avec l'université qui a conféré le grade.

La qualité d'impression de certaines pages peut laisser à désirer, surtout si les pages originales ont été dactylographiées à l'aide d'un ruban usé ou si l'université nous a fait parvenir une photocopie de mauvaise qualité.

Les documents qui font déjà l'objet d'un droit d'auteur (articles de revue, examens publiés, etc.) ne sont pas microfilmés.

La reproduction, même partielle, de ce microfilm est soumise à la Loi canadienne sur le droit d'auteur, SRC 1970, c. C-30. Veuillez prendre connaissance des formules d'autorisation qui accompagnent cette thèse.

**LA THÈSE A ÉTÉ
MICROFILMÉE TELLE QUE
NOUS L'AVONS REÇUE**

THE UNIVERSITY OF ALBERTA

INFLUENCE OF WATER FLOW AND PARTICLE CONCENTRATION
ON LARVAE OF THE BLACK FLY *SIMULIUM VITTATUM* ZETT.
(DIPTERA:SIMULIIDAE), WITH EMPHASIS ON LARVAL FILTER-FEEDING

by

MARY MACCRIMMON CHANCE

A THESIS

SUBMITTED TO THE FACULTY OF GRADUATE STUDIES AND RESEARCH
IN PARTIAL FULFILMENT OF THE REQUIREMENTS FOR THE DEGREE

OF DOCTOR OF PHILOSOPHY

IN

DEPARTMENT OF ENTOMOLOGY

EDMONTON, ALBERTA

(FALL, 1977)

FRONTISPIECE

BOUNDARY LAYER AROUND FILTER-FEEDING
LARVA OF SIMULIUM VITTATUM

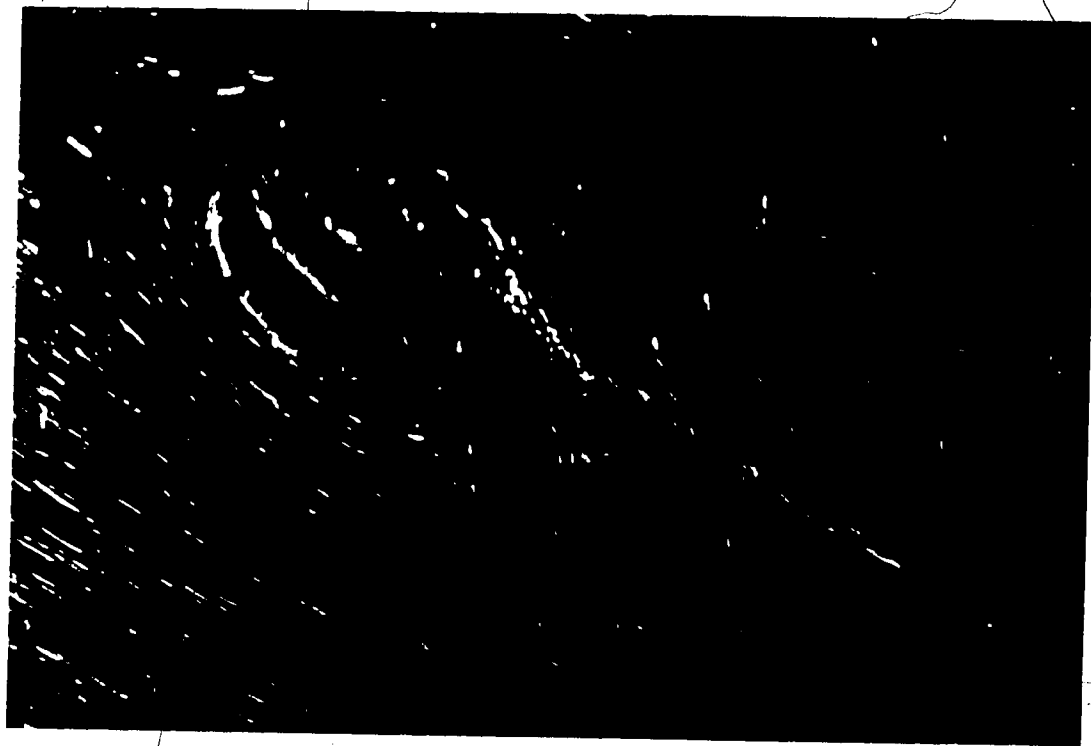

THE UNIVERSITY OF ALBERTA

FACULTY OF GRADUATE STUDIES AND RESEARCH

The undersigned certify that they have read, and recommend to the Faculty of Graduate Studies and Research, for acceptance, a thesis entitled: Influence of water flow and particle concentration on larvae of the black fly, *Simulium vittatum* Zett. (Diptera: Simuliidae) with emphasis on larval filter-feeding, submitted by Mary MacCrimmon Chance in partial fulfilment of the requirements for the degree of Doctor of Philosophy.

D. A. Craig
.....
Supervisor

Robert F. Chubb
.....
J. S. Nelson
.....

B. A. Heming
.....

Richard W. Merritt
.....
External Examiner

Date *25th August 1977*
.....

ABSTRACT

Water flow profiles around individual larvae of the black fly *Simulium vittatum* Zett. demonstrate a velocity gradient, areas of turbulence, and boundary layers. A photographic technique provides two- and three-dimensional velocity vector profiles around individual larvae under laboratory conditions. Larval posture is determined by water velocity and provides a means of reducing the force of the current which larvae must withstand. Most of the body of a filtering larva, and the entire larva exhibiting an avoidance reaction, are contained within the substratum boundary layer.

Laboratory studies demonstrate the influence of water velocity and particle concentration on filter-feeding by larvae of three size classes and parasitized larvae. Within each larval class and among parasitized larvae there is variation in rate of gut filling, however, there is no difference in rates of gut filling between larvae of different size classes and parasitized larvae. Larvae of all size classes and parasitized larvae filled their guts most rapidly when exposed to availabilities of particles of 100 - 200 particles/ml/sec, which occurred as a result of exposure to water velocities of 5 - 10 cm/sec and particle concentrations of 4 - 40 particles/ml. At higher or lower particle availabilities the rate of gut filling is reduced.

A proportion of larvae of all size classes do not feed for periods of 90 minutes or longer. This proportion of larvae which do not feed decreases from small to large larvae, and is smaller among parasitized larvae than healthy larvae.

PREFACE

After graduating from high school in Montreal, I attended McGill University (Montreal). I took a four year programme graduating in 1965 with a Bachelor of Science degree with a first class in Honours Zoology. I was awarded the Fantham Memorial Prize in Zoology (McGill; 1965).

During my last years at McGill I decided to pursue my interest in zoology. I became particularly interested in entomology after taking a course in arthropod biology. I spent the summer of 1965 at the Entomology Research Institute in Belleville, Ontario as a summer assistant to Dr. P. Belton. I worked on a survey of mosquitoes of the Belleville area.

When I applied for graduate work at the University of Alberta, Dr. Hocking offered me the opportunity of working on the feeding biology of black flies. I completed a Masters' Programme in 1969, which included a study of the functional morphology of the mouthparts of black fly larvae. I have continued my studies on feeding by larval black flies, concentrating on the feeding behaviour of the larvae.

While at the University of Alberta, I was awarded Postgraduate scholarships in 1965 and 1966 by the Ministry of Education of Quebec, a National Research Council of Canada Postgraduate Scholarship in 1966 - 1970, a University of Alberta Dissertation Fellowship in 1971 - 1972, and the Entomological Society of Alberta Prize in 1966.

In July 1974 I began a one-year appointment as a research assistant at the University of Waterloo (Ontario), working with Dr. S.M. Smith, and formed part of a team compiling a comprehensive report on mosquitoes and mosquito control in Ontario for the Ontario Provincial government. While at the University of Waterloo, I was appointed for five years to the Scientific Advisory Panel of the World Health Organization for Control of Onchocerciasis.

In September of 1975, I returned to Quebec when my husband began teaching at a junior college (John Abbott College) in Ste. Anne de Bellevue. In January of 1976, I began working part time as a research assistant at the Lyman Museum and Research Library of Macdonald College (McGill University), conducting a survey of the Anoplura and Mallophaga of Quebec. In September 1976 I joined my husband as a teacher in the Biology Department of John Abbott College and I continue my association with the Lyman Museum.

Publications and Theses

- Chance, M.M. 1969. Functional morphology of the mouthparts of blackfly larvae (Diptera:Simuliidae). M.Sc. Thesis, University of Alberta, 132 pp.
- Chance, M.M. 1970. The functional morphology of the mouthparts of blackfly larvae (Diptera:Simuliidae). Quaest. ent. 6: 245-284.
- Chance, M.M. 1970. A review of chemical control methods for blackfly larvae (Diptera:Simuliidae). Quaest. ent. 6: 287-292.
- Belton, P. and M.M. Galloway. 1966. Light-trap collections of mosquitoes near Belleville, Ontario in 1965. Proc. ent. Soc. Ont. 96: 90-96.
- Marsden, J.R. and M.M. Galloway. 1968. The microanatomy of the supraoesophageal ganglion of *Eurythroë complanata* (Polychaeta: Amphinomidae). Can. J. Zoo. 46: 349-368.
- Smith, S.M., M.M. Chance, R.G.H. Downer, and R.E. Wright. 1976. Mosquitoes and mosquito control in Ontario. Report submitted to the Ontario Pesticides Advisory Committee. 687 pp. (unpublished).

ACKNOWLEDGEMENTS

I thank Dr. D.A. Craig, Chairman of my committee, for his very helpful supervision. His friendship and interest in my work made the study more enjoyable. I would like to express my appreciation for the interest and suggestions of the late Dr. B. Hocking, former Chairman of the Department of Entomology.

I owe special thanks to Dr. D.J. Wilson, Department of Mechanical Engineering, University of Alberta, for his advice on velocity measurements and the loan of an anemometer; and to Mr. A. Charbonneau, formerly of the Department of Civil Engineering, University of Alberta, for his assistance, including the loan of a Kent Miniflo-265 paddlemeter and a prototype hydraulic flume. Dr. F.D. Otto, Department of Petroleum Engineering, University of Alberta, kindly gave me permission to use the digitizer, and I am grateful to Dr. A. Rollin for his advice, and Mr. R. Parker for his assistance in using the digitizer.

I thank Dr. B. Chernick, Department of Zoology, University of Alberta, for her advice on statistical methods.

I would also like to thank Dr. S.M. Smith, Department of Biology, University of Waterloo, for making it possible for me to have access to the computer at the University of Waterloo. I am grateful to Dr. G.O. Poinar for identifying the nematode parasites for me.

My husband, M.A. Chance, wrote all the original computer programmes for this study, and without his understanding of the research problem this analysis would not have been done. For the many hours he spent writing these programmes, and for his encouragement and continued interest in my work, I am very grateful. I would also like to thank other members of the Department of Entomology with whom I have had many rewarding discussions.

My research was financed through a grant made by the World Health Organization to the late Dr. Hocking.. I also gratefully acknowledge receiving a National Research Council of Canada Postgraduate Scholarship and a University of Alberta Dissertation Fellowship.

TABLE OF CONTENTS

	Page
0.0. INTRODUCTION	1
1.0. WATER FLOW AROUND BLACK FLY LARVAE	
1.1. LITERATURE REVIEW	
1.1.1. Introduction	3
1.1.2. Laboratory analysis of water flow around black fly larvae	8
1.2. MATERIALS AND METHODS	
1.2.1. Flume	12
1.2.2. Larval posture	14
1.2.3. Photographic system	14
1.2.4. Analysis	20
1.3. RESULTS	
1.3.1. Behaviour of larvae with respect to current	
1.3.1.1. Larval orientation	22
1.3.1.2. Flow profiles around larvae	29
1.3.1.3. Avoidance reaction	40
1.3.2. Velocity profiles around larvae	
1.3.2.1. Two-dimensional profiles	40
1.3.2.2. Three-dimensional profiles	47
1.4. DISCUSSION	
1.4.1. Larval orientation	60
1.4.2. Flow profiles around larvae	63

	Page
1.4.3. Velocity profiles around larvae	66
1.4.4. Discussion of technique	68
1.4.4.1. Sources of error in velocity measurement....	68
1.4.4.2. Advantages and disadvantages of the technique	69
1.5. CONCLUSION	71
2.0. FEEDING BEHAVIOUR OF BLACK FLY LARVAE	
2.1. LITERATURE REVIEW	74
2.2. MATERIALS AND METHODS	
2.2.1. Experimental design	79
2.2.2. Measurement of water velocity	83
2.2.3. Measurement of concentration of particles	85
2.3. RESULTS	
2.3.1. Experimental conditions	86
2.3.2. Parasitism	94
2.3.3. Feeding analysis	96
2.3.3.1. Feeding distributions	96
2.3.3.2. Feeding results	96
i. Ingestion among larval classes within experiments	99
ii. Ingestion within larval class among experiments	103
iii. Comparison of ingestion after grouping experiments	118
iv. Ingestion within 'doubled' experiments	121

	Page
v. Comparison of mean percentage gut filled between larval classes	123
vi. Proportion of larvae which did not feed	123
2.4. DISCUSSION	
2.4.1. Parasitism	144
2.4.2. Experimental design	146
2.4.3. Experimental conditions	148
2.4.4. Ingestion	151
2.4.4.1. Ingestion and availability of particles ...	151
2.4.4.2. Ingestion among larval classes	152
2.4.4.3. Ingestion within larval class	156
2.4.4.4. Ingestion within larval class among periods of feeding	160
2.4.4.5. Ingestion under similar conditions	161
2.4.4.6. Proportions of larvae which did not feed ..	162
2.5. CONCLUSION	167
3.0. GENERAL CONCLUSION	170
4.0. LITERATURE CITED	171
0. APPENDIX	181

LIST OF TABLES

Table	Description	Page
1.1.	Rates of water flow (cm/sec) recorded by a midget current meter and vectors for two- and three-dimensional profiles around a larva of <i>Simulium vittatum</i> . Angles of deflection of larvae are included. . .	42
2.1.	Velocity, concentration and availability of particles to which larvae of <i>Simulium vittatum</i> were exposed, and numbers of larvae in flume.	92
2.2.	Percentage of unfed larvae of <i>Simulium vittatum</i> in each class.	93
2.3.	Availability of particles, after adjustment for size of particle, to larvae of <i>Simulium vittatum</i>	95
2.4.	Mean percentage gut filled in larvae of 4 classes of <i>Simulium vittatum</i>	98
2.5.	Ingestion by larvae of <i>Simulium vittatum</i> within 'doubled' experiments.	122
2.6.	Percentage of unfed larvae in each of 4 larval classes of <i>Simulium vittatum</i> within 'doubled' experiments..	143
2.7.	Records of water velocities in which larvae of <i>Simulium vittatum</i> have been found.	149
2.8.	Mean and relative sizes of cephalic fans and guts of larvae of 4 larval classes of <i>Simulium vittatum</i>	153

	Page
APPENDIX A. Flume velocity data and mean velocity vectors at selected coordinates about larvae.	181
APPENDIX B. Calculation of mean concentration of particles to which larvae were exposed.....	195
APPENDIX C. Estimates of mean concentration of particles for each experiment.	197
APPENDIX D. Numbers of larvae of <i>Simulium vittatum</i> in each class and total numbers of larvae examined in each experiment.	198
APPENDIX E. Parasitism of larvae of <i>Simulium vittatum</i>	199
APPENDIX F. Numbers of larvae of <i>Simulium vittatum</i> in each class with mean (arcsine) percentage gut filled..	200
APPENDIX G. Table I. Mean (arcsine) percentage gut filled of larvae of <i>Simulium vittatum</i>	227
Table II. Differences between means of (arcsine) percentage gut filled by larvae of <i>Simulium vittatum</i> determined by Duncan's New Multiple Range Test.	228
APPENDIX H. Tests of independence (G-Test) between feeding, larval class, and experiments.	231

LIST OF FIGURES

	Page
Fig. 1.1. Diagram of flume.....	13
Fig. 1.2. Diagram of equipment for filming three-dimensional views of black fly larvae.....	17
Fig. 1.3. Aluminium dispenser.....	19
Fig. 1.4. Photograph of a larva of <i>Simulium vittatum</i>	25
Fig. 1.5. Angle of deflection of larvae of <i>Simulium vittatum</i> plotted against rate of water flow.....	26
Fig. 1.6. Mean angle of deflection of larvae of <i>Simulium vittatum</i> and height of larval heads above substratum plotted against rate of water flow....	28
Fig. 1.7. Two-dimensional flow profile around a larva of <i>Simulium vittatum</i> while filtering and rotated less than 180 degrees. Lateral view.....	30
Fig. 1.8. Two-dimensional flow profile around a larva of <i>Simulium vittatum</i> while filtering and rotated approximately 90 degrees. Lateral view..	30
Fig. 1.9. Two-dimensional flow profile around a larva of <i>Simulium vittatum</i> while filtering and rotated approximately 180 degrees. Lateral view.	31
Fig. 1.10. Two-dimensional flow profile around a larva of <i>Simulium vittatum</i> while 'crouching'. Lateral view.	31
Fig. 1.11. Two-dimensional flow profile around a larva of <i>Simulium vittatum</i> while filtering. Dorso-ventral view.	32
Fig. 1.12. Photograph of a filtering larva of <i>Simulium vittatum</i> in a water flow.....	35
Fig. 1.13. Photograph of a larva of <i>Simulium vittatum</i> while 'crouching' in a water flow.	35
Fig. 1.14. Photograph of a filtering larva of <i>Simulium vittatum</i> attached to a wall of the flume and in a water flow.	37

	Page
Fig. 1.15. Photograph of a larva of <i>Simulium vittatum</i> and a prism image of larva in a water flow.....	37
Fig. 1.16. Photograph of a larva of <i>Simulium vittatum</i> in a water flow and a boundary layer around larval body	39
Fig. 1.17. Photographs of filtering larva of <i>Simulium vittatum</i> in a water flow.	
Fig. 1.17a. Larva with one fan extended.....	39
Fig. 1.17b. Larva with both fans retracted.....	39
Fig. 1.18. Mean velocity vectors at selected coordinates about a filtering larva of <i>Simulium vittatum</i> while exposed to 'faster' water flow. Lateral view.	44
Fig. 1.19. Mean velocity vectors at selected coordinates about a filtering larva of <i>Simulium vittatum</i> while exposed to 'slower' water flow. Lateral view.	44
Fig. 1.20. Mean velocity vectors at selected coordinates about a larva of <i>Simulium vittatum</i> while 'crouching'.....	46
Fig. 1.21. Mean velocity vectors at selected coordinates about a filtering larva of <i>Simulium vittatum</i> . Dorso-ventral view.....	46
Fig. 1.22. Mean velocity vectors at selected coordinates about a larva of <i>Simulium vittatum</i> . Three-dimensional profile with a coordinate interval of 1.0 mm.....	49
Fig. 1.23. Mean velocity vectors at selected coordinates about a larva of <i>Simulium vittatum</i> .	
Fig. 1.23a. Three-dimensional profile with a coordinate interval of 1.0 mm.....	53
Fig. 1.23b. Three-dimensional profile with a coordinate interval of 2.0 mm.....	57
Fig. 2.1. Calibration vessel for hot film probe.....	84
Fig. 2.2. Regression of logarithm concentration of particles with time, as an example of reduction of particle concentration with time (experiment #15a).....	88

	Page
Fig. 2.3a. Mean (arcsine) percentage gut filled by 4 classes of larvae of <i>Simulium vittatum</i> after exposure to a range of availabilities of particles for 30 minutes.	100
Fig. 2.3b. Mean (arcsine) percentage gut filled by 4 classes of larvae of <i>Simulium vittatum</i> after exposure to a range of availabilities of particles for 60 minutes.....	101
Fig. 2.3c. Mean (arcsine) percentage gut filled by 4 classes of larvae of <i>Simulium vittatum</i> after exposure to a range of availabilities of particles for 90 minutes.	102
Fig. 2.3d. Mean (arcsine) percentage gut filled by large larvae of <i>Simulium vittatum</i> after exposure to a range of availabilities of particles for 30 minutes.	104
Fig. 2.3e. Mean (arcsine) percentage gut filled by large larvae of <i>Simulium vittatum</i> after exposure to a range of availabilities of particles for 60 minutes.	105
Fig. 2.3f. Mean (arcsine) percentage gut filled by large larvae of <i>Simulium vittatum</i> after exposure to a range of availabilities of particles for 90 minutes.	106
Fig. 2.3g. Mean (arcsine) percentage gut filled by medium larvae of <i>Simulium vittatum</i> after exposure to a range of availabilities of particles for 30 minutes.	108
Fig. 2.3h. Mean (arcsine) percentage gut filled by medium larvae of <i>Simulium vittatum</i> after exposure to a range of availabilities of particles for 60 minutes.	109
Fig. 2.3i. Mean (arcsine) percentage gut filled by medium larvae of <i>Simulium vittatum</i> after exposure to a range of availabilities of particles for 90 minutes.	110
Fig. 2.3j. Mean (arcsine) percentage gut filled by small larvae of <i>Simulium vittatum</i> after exposure to a range of availabilities of particles for 30 minutes.	111
Fig. 2.3k. Mean (arcsine) percentage gut filled by small larvae of <i>Simulium vittatum</i> after exposure to a range of availabilities of particles for 60 minutes.	112
Fig. 2.3l. Mean (arcsine) percentage gut filled by small larvae of <i>Simulium vittatum</i> after exposure to a range of availabilities of particles for 90 minutes.....	113

	Page
Fig. 2.3m. Mean (arcsine) percentage gut filled by large parasitized larvae of <i>Simulium vittatum</i> after exposure to a range of availabilities of particles for 30 minutes.	115
Fig. 2.3n. Mean (arcsine) percentage gut filled by large parasitized larvae of <i>Simulium vittatum</i> after exposure to a range of availabilities of particles for 60 minutes.	116
Fig. 2.3o. Mean (arcsine) percentage gut filled by large parasitized larvae of <i>Simulium vittatum</i> after exposure to a range of availabilities of particles for 90 minutes.	117
Fig. 2.4a. Percentage of larvae in each of 4 larval classes of <i>Simulium vittatum</i> which did not feed during exposure to a range of availabilities of particles for 30 minutes.	127
Fig. 2.4b. Percentage of larvae in each of 4 larval classes of <i>Simulium vittatum</i> which did not feed during exposure to a range of availabilities of particles for 60 minutes.	128
Fig. 2.4c. Percentage of larvae in each of 4 larval classes of <i>Simulium vittatum</i> which did not feed during exposure to a range of availabilities of particles for 90 minutes.	129
Fig. 2.4d. Percentage of large larvae of <i>Simulium vittatum</i> which did not feed during exposure to a range of availabilities of particles for 30 minutes.	130
Fig. 2.4e. Percentage of large larvae of <i>Simulium vittatum</i> which did not feed during exposure to a range of availabilities of particles for 60 minutes.	131
Fig. 2.4f. Percentage of large larvae of <i>Simulium vittatum</i> which did not feed during exposure to a range of availabilities of particles for 90 minutes.	132
Fig. 2.4g. Percentage of medium larvae of <i>Simulium vittatum</i> which did not feed during exposure to a range of availabilities of particles for 30 minutes.	133
Fig. 2.4h. Percentage of medium larvae of <i>Simulium vittatum</i> which did not feed during exposure to a range of availabilities of particles for 60 minutes.	134

	Page
Fig. 2.4i. Percentage of medium larvae of <i>Simulium vittatum</i> which did not feed during exposure to a range of availabilities of particles for 90 minutes.	135
Fig. 2.4j. Percentage of small larvae of <i>Simulium vittatum</i> which did not feed during exposure to a range of availabilities of particles for 30 minutes.	136
Fig. 2.4k. Percentage of small larvae of <i>Simulium vittatum</i> which did not feed during exposure to a range of availabilities of particles for 60 minutes.	137
Fig. 2.4l. Percentage of small larvae of <i>Simulium vittatum</i> which did not feed during exposure to a range of availabilities of particles for 90 minutes.	138
Fig. 2.4m. Percentage of large parasitized larvae of <i>Simulium vittatum</i> which did not feed during exposure to a range of availabilities of particles for 30 minutes.	139
Fig. 2.4n. Percentage of large parasitized larvae of <i>Simulium vittatum</i> which did not feed during exposure to a range of availabilities of particles for 60 minutes.	140
Fig. 2.4o. Percentage of large parasitized larvae of <i>Simulium vittatum</i> which did not feed during exposure to a range of availabilities of particles for 90 minutes.	141
Fig. A.1. Axes of three-dimensional velocity profiles.	187
Fig. B.1. Plot of particle concentration against time.	195
Fig. B.2. Plot of particle concentration against time in 'doubled' experiments.	195

0.0. INTRODUCTION

Black flies are among the world's major pest insects. In the old and new world tropics, female black flies transmit onchocerciasis, a widespread disease which causes severe medical, economic, and social problems. In temperate areas black flies are important pests of livestock, domestic birds, and wildlife. In addition to transmitting diseases, black flies cause intense suffering to both man and other animals through their bites when they are abundant.

The most successful efforts at controlling black flies have been directed at the larval stage (Chance 1970a). Efficient and selective control programmes are those in which a particulate insecticide is used. The efficiency of these insecticides appears to depend on the unselective nature of the filter-feeding behaviour of black fly larvae.

Black fly larvae are aquatic animals which live exclusively in lotic habitats. In this environment, the flow of water is the dominant physical factor, having a major influence on stream life directly through the mechanical force it exerts on stream organisms, and indirectly through its effect on their substratum and food supply.

The force of the current poses a severe hazard to lotic animals and most stream fauna seek shelter from the current. However, as black fly larvae are passive filter-feeders, they depend on a flow of water for their food supply.

An important and little studied component of the lotic habitat is

a layer of slow moving water -- the so-called boundary layer -- which occurs over the surface of the substratum. Benthic organisms, including black flies, are small enough to live within this layer of water.

This study is a contribution to a better understanding of the filter-feeding behaviour of black fly larvae. The study is in two parts: first, an examination of water flow in the immediate vicinity of the larvae and its influence on larval behaviour, and second, an investigation of the influence of the rate of water flow and concentration of food on ingestion by black fly larvae.

1.0. WATER FLOW AROUND BLACK FLY LARVAE

1.1. LITERATURE REVIEW

1.1.1. Introduction

The ecology of lotic habitats has been reviewed recently by Hynes (1970a, b). He considered the nature and influence of water flow as well as adaptations of stream organisms to their environment. Flow conditions to which the stream benthos are exposed have been studied in detail by Dorier and Vaillant (1954), Ambühl (1959, 1961, 1962), Jaag and Ambühl (1964), and Trivellato and Décamps (1968). Ambühl (1959) demonstrated for the first time the significance of the boundary layer to which the benthos is exposed.

Rate of water movement in a lotic system varies with depth and proximity to submerged objects. Over the cross-sectional area of flow, the speed of water is reduced by friction with adjacent materials. Thus bottom flow is reduced by its contact with the substratum and surface flow is reduced by its contact with air. Speed of flow in a watercourse increases with depth to a maximum rate at about one-third the depth of the watercourse. It then decreases rapidly with depth until it approaches zero along the substratum. This area of decreasing flow is the boundary layer ('Grenzschichtdicht' of Ambühl or 'Grenzschicht' of Ruttner). Thickness of boundary layer is dependent on rate of water flow, viscosity, depth of water and texture of substratum. Boundary layers also occur along banks of watercourses and over submerged objects.

The relationship between water flow and substratum type is well described (Inman 1949, Cummins 1962, Cummins and Lauf 1969) and reviewed by Ruttner (1963) and Hynes (1970a). Rate of water flow determines nature and stability of the substratum. The faster the water flow, the greater is its ability to transport materials. The greater carrying capacity is reflected in larger size of particle transported. As a result, bottoms of fast-flowing streams consist generally of large, clean boulders and larger stones; smaller particles are carried or rolled along by the current. Watercourses with slow water flow have substrata consisting of smaller particles, e.g. pebbles, gravel, sand, and silt.

Water velocity, i.e. both rate and direction of water movement, varies over the substratum of natural watercourses as it flows over and around rocks, plants, and other submerged objects (Clemens 1917, Grenier 1949, Dorier and Vaillant 1954, Ulfstrand 1967). Rate of flow over the upstream surface of rocks is greater than that over the downstream surface. Allen (1959) estimated this range of maximum to minimum current speed to be 2:1. Flow over the upper surfaces of submerged objects is also smoother because water is forced to flow through a smaller cross-sectional area. The increase in speed and regularity of flow over upstream surfaces is called the 'nozzle effect' (Ulfstrand 1967). Areas immediately downstream from submerged objects are areas of eddy formation and sedimentation. Flow is reduced and transported materials tend to settle out and accumulate.

Ulfstrand (1967) and Trivellato and Décamps (1968) illustrated the relationship between velocity, turbulence, eddy formation, and obstacles in the current. In fast flows, eddies formed in the downstream areas of submerged obstacles are more stable than eddies formed in slower flows. Water movement is greater in eddies, and therefore the exchange of materials between flow along the substratum and the mainstream is increased when eddies are formed.

Studies of the distribution of benthic invertebrates have shown that most of the fauna live in areas of reduced flow. They are not exposed to the full force of the current but live in confined areas: the interstitial spaces among rocks and pebbles, and among vegetation. These areas are mis-named 'dead water spaces' in which rate of flow is reduced and detritus collects. Exceptions are some species which live in sheltered areas and leave these areas in order to feed (Hynes 1970a). Animals which do live in exposed areas of substratum get protection in the boundary layer. Ambühl (1959) showed that the boundary layer may be several millimeters thick and large enough to contain benthic animals.

Benthic fauna have various adaptations for survival in flowing water. These are reviewed most recently by Hynes (1970a, b) and Bournaud (1963). Black fly larvae are adapted for their life in lotic water by their size and shape, method and site of attachment, and feeding behaviour. They are small, hemicylindrical animals, attaining a maximum length of approximately one centimeter. Bournaud (1972) disputes that smallness is an adaptation specific to life in flowing water; however, small animals offer less resistance to current than do

large ones (Grenier 1949) as they are closer to the substratum and get greater protection from the boundary layer. Black fly larvae are streamlined; their body is smooth and has few projections. In addition to their retractable anal papillae, larvae have a single, thoracic proleg. Their streamlining is also enhanced by the orientation of larvae to the current.

Black fly larvae select areas for attachment where flow is fast, for example, the upstream surface of submerged objects and trailing vegetation (Tonnoir 1925, Grenier 1949, Zahar 1951, Hocking and Pickering 1954, Peterson 1956, Maitland and Penney 1967, Chutter 1968, Lewis and Bennett 1975). Larvae select these areas for attachment because the substratum tends to be clean and free of sediments (Sommerman et al 1955; Carlsson 1962, 1967) and their method of feeding is more efficient in smooth water flow (Wolfe and Peterson 1959, Hynes 1970a). Velocity preferences of larvae vary with species, and is reflected in the distribution of larvae (Phillipson 1956, 1957; Carlsson 1967; Maitland and Penney 1967; Kurtak 1973).

The method of larval attachment has been described in detail by Tonnoir (1922), Puri (1925), Hora (1927), Grenier (1949) and Serratosio (1967). Larvae first apply a sticky salivary secretion to the substratum, and then attach themselves to it with a circlet of hooks located at the posterior end of the abdomen. Once attached, larvae do not expend any energy in maintaining their position against the current. The larvae are normally sedentary. They avoid the hazard of moving around in search of food and being swept away by the current.

Larval orientation has been described by Tonnoir (1922), Puri (1925), Fortner (1937), Grenier (1949), Peterson (1956), Serra-Tosio (1967) and Kurtak (1973). Larvae attach themselves with their dorsal surface facing the current. They rotate their bodies from 90° - 180° around the longitudinal axis so that the ventral surface of the head and fans face the current. The larval body is deflected by the current and the head is downstream from the body. The amount the body is deflected varies with rate of flow; in faster currents, larvae lie closer to the substratum (Wu 1931, Fortner 1937, Maitland and Penney 1967, Kurtak 1973). This posture is considered a passive body reflex (Tonnoir 1922, Grenier 1949, Maitland and Penney 1967). Kurtak (1973) reported differences in feeding posture between different species exposed to the same velocity.

Black fly larvae feed by filtering water with specialized cephalic fans and collecting particulate material carried by the current (Chance 1970a, and sect. 2.0.). They are passive filter-feeders because they do not create their own current of water, as do active filter-feeders, but rely on the flow of water in lotic systems to transport their particulate food. It is because they are passive filter-feeders that lotic species are rheostenic animals.

When larvae are disturbed, they interrupt their feeding and exhibit a characteristic behaviour of pulling themselves down to the substratum and bringing their entire body into the boundary layer (Tonnoir 1922, Grenier 1949). If the disturbance is severe, for example, a sudden increase in rate of water flow, the larvae may

form a second attachment to the substratum with their thoracic proleg, thereby reinforcing the initial attachment. This behaviour is called here an 'avoidance reaction' and is an adaptation whereby larvae make use of the boundary layer.

1.1.2. Laboratory analysis of water flow around black fly larvae

Investigations into habits of stream inhabiting invertebrates have been handicapped because of difficulties in measuring rates of water flow to which these animals are exposed. Various workers have shown that rates of flow to which benthic organisms are exposed are considerably slower than that of the mainstream (Clemens 1917, Hubault 1927, Gessner 1950, Ambühl 1959, Bournaud 1963, Trivellato and Décamps 1968). However, measurements of these water velocities are very difficult because of the nature of flow and the small size of these areas.

Some of the earlier studies on the lotic benthos relied on surface velocities as estimates of flow along the substratum. Allen (1951) used surface velocity measured with a float as an estimate of flow; Scott (1958) described a linear relationship between velocity at the surface and velocity along the substratum, as measured with a pitot tube. Bournaud (1963) stated that surface velocity represents the average velocity of flow. The ease and rapidity with which surface velocities can be measured do much to recommend their use as estimates of flow. However, studies of the last several years have made it increasingly obvious that accurate measurements of the microcurrents to which benthic animals are exposed are essential for a comprehensive

understanding of the interaction between these animals and their environment. Surface velocity measurements, or even measurements made within a few centimeters of the substratum, are inadequate.

Several workers have discussed the problems of measuring flow in confined areas (Welch 1948, Bournaud 1963). Hynes (1970a) gives the most recent and comprehensive review.

Standard flowmeters designed for hydrobiological studies are too large for measuring microcurrents. Even miniaturized versions are generally unsatisfactory due to their size. The smallest of these flowmeters are usually not sufficiently sensitive to measure slow velocities.

Commercially available flowmeters are of two basic types: differential pressure flowmeters and paddle or blade meters. Differential pressure flowmeters, including pitot tubes and bentzel current meters, cannot measure velocities of less than 10 cm/sec. Problems posed by capillary forces and air bubbles restrict the use of miniaturized versions. These flowmeters are also difficult to use in turbulent and fluctuating flows. Brundritt (1971) has designed a differential pressure flowmeter which appears to overcome these problems and measures flow accurately to a depth of only 2 mm.

Paddle meters are generally used for field work. Several, including the Leupold-Stevens pigmy and midget current meters (Cummins 1962, Eriksen 1966), the Ott propeller (Ulfstrand 1968a, Elliott 1970, 1971), and the Kent miniflow-265 (Phillipson 1956) are considered

adequate for field studies although they are too large to measure microcurrents. Their sensing heads range from 1.0 to 2.5 cm or more in diameter. Again, these cannot measure slow velocities. In addition, they have frictional problems between moving parts, and tend to clog with floating debris. Some are subject to corrosion in water. Those requiring direct counting of blade rotation are difficult to use in flows which rotate the blades rapidly.

Several workers have designed other techniques. Edington and Molyneux (1960) developed a portable paddle flowmeter which measures flows as low as 5 cm/sec with a sensing head of 1.5 cm in diameter. Bournaud (1963) developed a measuring device for laboratory studies consisting of a simple blade and a balance beam with a cursor. Gessner (1950) developed a technique by which water flow is determined from the collection of water passing through a small hole of known diameter. The device is simple and consistent. McConnell and Sigler (1959) developed a unique system for measuring flow at the substratum by measuring the rate of dissolution of salt tablets. This system has great advantage because it takes into account conditions of flow at the substratum, however, it is not very precise and is difficult to calibrate. Their results were subject to variation. Kurtak (1973) developed a pressure transducer to measure point velocities.

A more sophisticated type of current meter with a sensing head of sufficiently small size is the hot wire, or hot film, anemometer (Sect. 2.2.2.). This device measures the rate of heat loss from a heated wire or film to a passing fluid, either air (anemometer) or

liquid (rheometer). They are very sensitive, but also fragile and expensive. They are susceptible to contaminants in the water and to mechanical damage from floating debris. For these reasons they tend to be restricted to laboratory use although robust versions are now being designed for use in natural watercourses. The increase in strength is achieved with a loss in sensitivity.

Most of these meters are not small and sensitive enough to measure flow in the boundary layer, or in the immediate vicinity of small benthic animals. The most accurate and detailed measurements of water flow, including studies of the boundary layer, have been achieved through photography. These studies are restricted to the laboratory, where flow can be analyzed under artificial conditions. Movement of water, both quantitative and qualitative, is studied after adding particles to the water and filming their movement under a flashing light. Particles are selected for shape and size, specific gravity and reflectivity. In situations where animals are being studied, non-toxic particles are used. Synthetic beads (Ambühl 1959, Allan 1961); aluminium particles (Hersh 1960, Trivellato and Décamps 1968), and the tobacco mosaic virus (Hersh 1960) have been used.

Crisp and Southward (1956, 1961) used cow's milk in their study of barnacle feeding. They found it easier to manipulate than particles in studying flows in sea water.

1.2. MATERIALS AND METHODS

1.2.1. Flume

Black fly larvae were maintained in a hydraulic flume (fig. 1.1.). This is a closed system consisting of an open channel (2.5 m long x 14.0 cm wide x 30.0 cm tall) and a head tank (61.0 cm tall x 30.5 cm long x 14.0 cm wide), both made of acrylic plastic (Plexiglas[®] 0.635 cm thick, purchased as $\frac{1}{4}$ -inch thick), a reservoir, and a pump to circulate the water. The walls of the flume were reinforced along the top with aluminium braces. A steel wire mesh at the entrance of the head tank reduced the turbulence of water entering the channel. The inflow of water into the channel from the head tank is controlled by a sluice gate. A tail gate at the end of the flume controlled the depth of water in the channel. The incline of the channel is adjustable, although throughout these experiments the channel was not inclined. A saran mesh filter in front of the tailgate prevented larvae from leaving the flume.

The reservoir (75.5 cm long x 51.0 cm wide x 50.0 cm deep) had insulated walls which were coated with non-toxic paint. An activated charcoal filter (9 kg) in the reservoir removed hypochlorite and heavy metal ions, and a water cooler (Frigid Unit Inc., 'Min-O-Cool', Toledo, Ohio) maintained the temperature of the water constant to within 1 C degree. For the experiments temperature ranged from 9C - 10C. The output of the waterpump (Rapidayton, The Tait Manufacturing Co., Dayton, Ohio) was controlled by a gate valve. The rate of flow of the

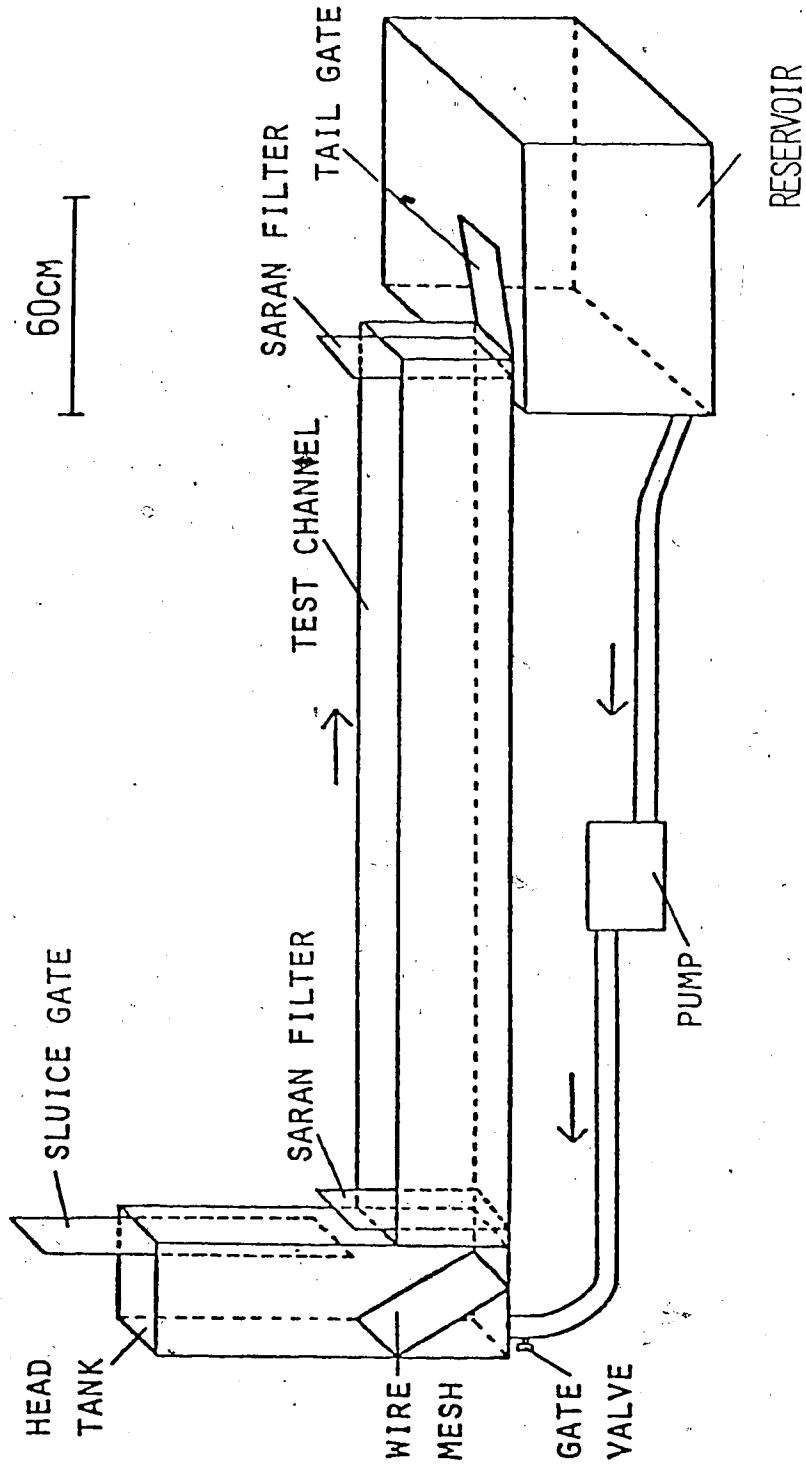

FIG. 1.1. DIAGRAM OF FLUME. ARROWS INDICATE DIRECTION OF WATER FLOW. (GATE VALVE AND PUMP NOT DRAWN TO SCALE),

mainstream of water in the channel ranged from 30 - 40 cm/sec.

The flume was filled with approximately 80 litres of deionized water. Movement of water kept it well oxygenated. Water was allowed to stand for a few days before being added to the flume, or if there were no larvae in the flume, allowed to circulate in the flume for a few days in order to remove chlorine.

Larvae were fed baker's yeast. Organic material which was added to the flume along with the larvae, and allowed to accumulate in the water, was also available as food.

1.2.2. Larval posture

Measurements of larval angle of deflection (Sect. 1.3.1.1.) were made by holding a protractor against the side wall of the flume and estimating the angle the larvae subtended to the substratum. Rate of flow of water to which larvae were exposed was measured with a Kent miniflo-265 paddlemeter (G. Kent Canada, Ltd., Toronto) held 0.75 cm above the substratum.

Measurements were also taken from films of larvae in the flume (Sect. 1.2.3.).

1.2.3. Photographic system

To visualize water flow around a larva, a suspension of aluminium flakes was released 3-4 cm upstream from the larva. A stroboscope (Type 1531-A Strobotac, General Radio Company) held about 15 cm above

the larva illuminated both larva and aluminium.

Still (35 mm) photographs were taken using a Nikkormat camera with either a Zoomar 90 mm f/2.8 Macro-Kilar lens or a 50 mm f/3.5 Micro-Nikkor lens. Kodak Tri-X film (ASA 400, developed for ASA 800) was used. Movie (16 mm) films were taken with a Bolex H16 camera with a Professional Kinotar lens and a 20 mm extension tube. Kodak 4-X Reversal film, type 7277, ASA 320, was used.

Two-dimensional views of larvae were photographed through the side wall of the flume with larvae attached either to the flume wall or to the edge of a sheet of Plexiglas (0.318 cm or 1/8-inch thick) positioned vertically 0.65 cm away from the flume wall. To provide a reference for magnification, a thin plastic ruler was positioned just below the site of attachment of the larvae being photographed.

Three-dimensional views were made by photographing a larva and its prism image at the same time. The camera was mounted vertically, above the flume, on a heavy aluminium brace which was clamped firmly to the flume to minimize vibrations due to the pump. The larva was allowed to attach to a Plexiglas form (60.0 cm long x 11.5 cm wide x 11.5 cm tall) with a right-angled triangular cross-section. The form was clamped against the wall of the flume about two-thirds of the way downstream, where the flow was relatively smooth. The upstream end of the form was streamlined to minimize turbulence over the surface of the form. The larva attached on the 45 degree slope, on a squared grid which provided a reference for magnification. A right-angled prism was positioned with one surface perpendicular to the larva and

parallel to the direction of flow, and another surface parallel to the bottom of the flume (fig. 1.2.). To compensate for the difference in lengths of light paths between the prism image and the target image, a plano-concave lens (A.L.) (focal length -73 or -206) was fixed between the upper surface of the prism and the water surface. To avoid problems from the air-water interface, a plexiglass disc (0.13 cm or $\frac{1}{2}$ -inch thick) was fixed at the water surface.

This technique provides two simultaneous two-dimensional (2-d) views, rather than a true three-dimensional (3-d) view (fig. 1.15).

To increase the contrast on the film, the laboratory was kept dark. The beam of the stroboscope was concentrated by attaching a plano-convex lens on the reflector. For the 35 mm films, additional lighting from two high-intensity lamps was necessary. In preliminary studies on larval orientation, 35 mm photographs were taken using a Braun flash for illumination. The flash provided satisfactory illumination. However, because the intensity of illumination varied over the period of the flash, paths of aluminium flakes are represented on the films by streaks with gradually tapering tails (figs. 1.16, 1.17). They therefore do not provide as precise a time record as do paths illuminated by the stroboscope.

The aluminium suspension consisted of 2.5 ml of aluminium flakes (type 905, Sheffield Bronze Powder Company, Ltd.), 600 ml of flume water, and 15 ml of Tergitol[®]. This aluminium powder was chosen from other powders tested on the basis of its size, and mixing and light-reflecting properties. The addition of Tergitol[®] was necessary for

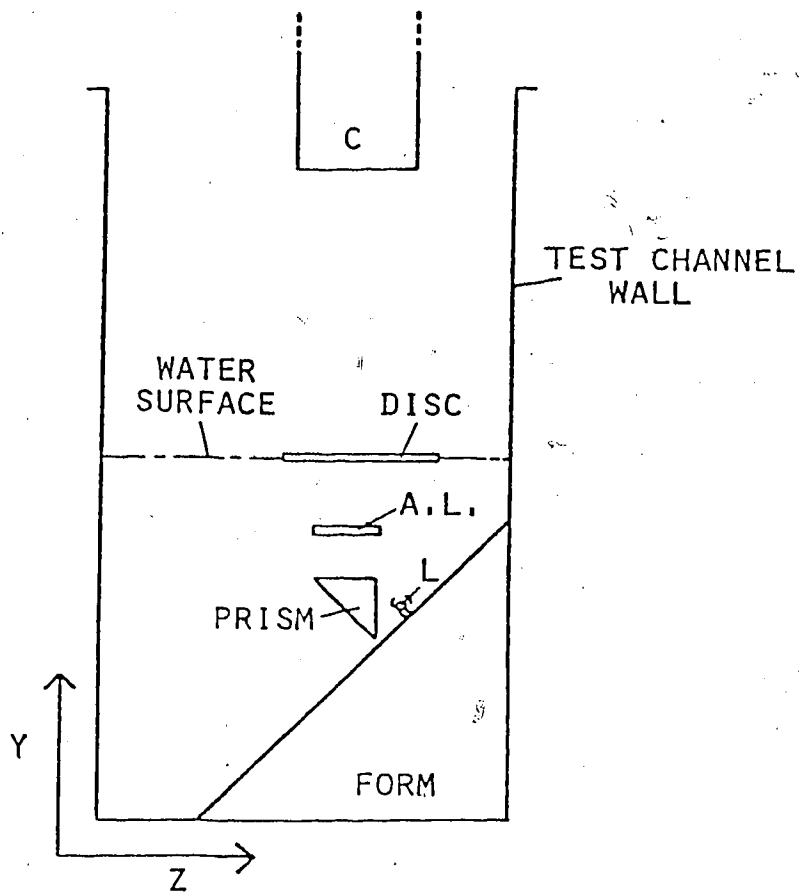

FIG. 1.2. DIAGRAM OF EQUIPMENT FOR FILMING 3-D VIEWS OF BLACK FLY LARVAE. A.L. = ACCESSORY LENS, C = CAMERA POSITION, L = LARVA, Y,Z = Y AND Z AXES (X AXIS PERPENDICULAR TO PLANE OF PAPER).

the aluminium to disperse readily in the water. The temperature of the suspension was kept at close to flume water temperature in an insulated dispenser. Since the aluminium tended to settle to the bottom of the container with time, it was kept in suspension by constant mixing with a magnetic stirrer (fig. 1.3).

The aluminium dispenser consisted of a modified nalgene screw top bottle (fig. 1.3.). A delivery tube, attached 1.0 cm above the base, was bent so that the tip was directed parallel to the water flow. The tip was tapered to minimize disruption of flow.

Discharge of the aluminium dispenser was controlled by a needle valve, connected to a straight tube passing through the cap of the bottle and down to a depth of 14.2 cm inside the bottle. The needle valve was calibrated so that the discharge was at a known rate, e.g. 99.06 ± 5.42 ml/min. A cheese-cloth filter at the exit of the flume removed most of the aluminium from the water as it flowed out of the flume.

Current speed during the filming was measured using a midget current meter (Leupold-Stevens Instruments Inc., Portland, Oregon) held a centimeter away from the larva, downstream and towards the centre of the flume. (A hot-wire anemometer was not available during this part of the study).

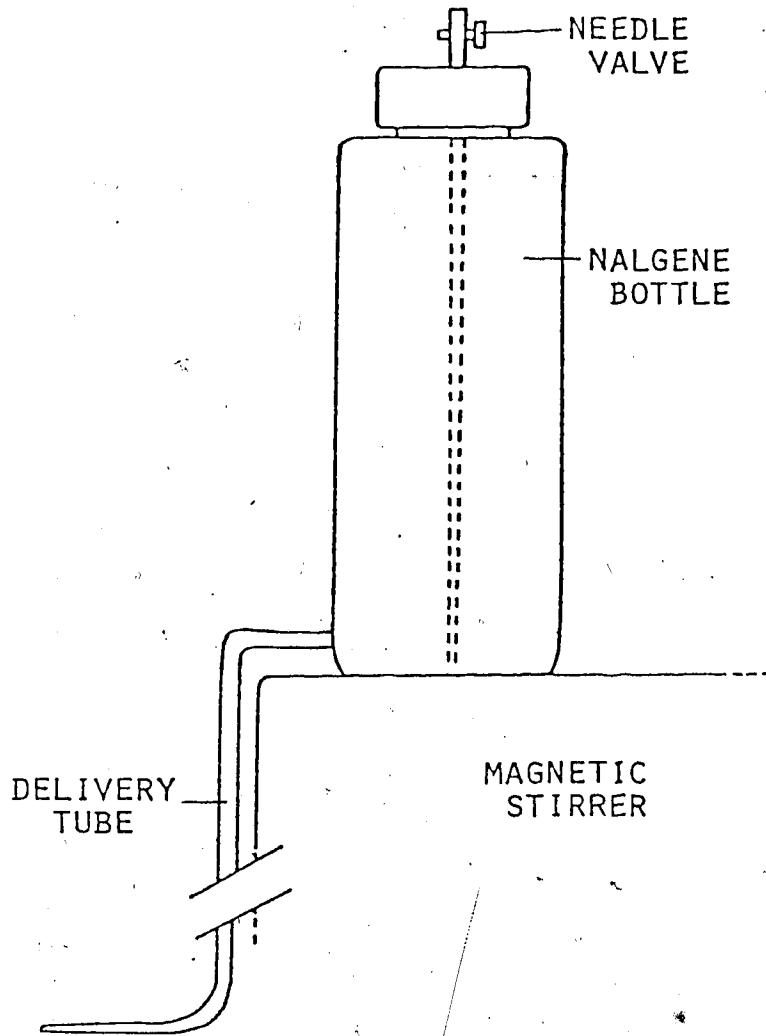

FIG. 1.3. ALUMINIUM DISPENSER

1.2.4. Analysis

The path a flake of aluminium travelled during the exposure time of the film shows up on the film as a row of dots (figs. 1.12 - 1.15). The distance between dots in a row is a measure of the speed a flake travelled while it was photographed. It is assumed that the aluminium flakes were carried freely by the water and that their movement was equal to that of the water.

The distance between dots of each row was measured using a digitizer and an IBM 360-67 computer. The digitizer is an analogue-digital converter consisting of a table with a movable cursor, a control circuit containing X and Y coordinate registers, and an output device which registers as voltages, points on a film projected onto a viewing table. The voltages were recorded automatically on computer cards. With a suitable computer programme, these voltages were analysed in the form of velocity vectors at selected coordinates around larvae. The direction and length of the vectors are averages of all paths of aluminium measured within the area defined by the computer programme. The programme takes into account the speed at which the film was taken, the speed of the stroboscope, and the magnification of the film.

The programme also mathematically compensates for the 45° incline on which larvae were attached by rotating the plane of larval attachment and of the prism image by 45° (fig. 1.2.). Thus the analysis is made with the larval substratum oriented parallel to the flume bottom, and the prism image perpendicular to the surface of the water and to the bottom of the flume.

To eliminate error due to the film slipping in the projector during digitizing, the position of each path of aluminium flake was recorded with reference to the position of the base of the larva in the same frame. The position of the larva is recorded with three coordinates: the midpoint of the base of the posterior end of the larva, the midpoint of an imaginary line between the thorax and abdomen, and a point midway between the cephalic fans. Since the upper part of the larva was constantly moving with the current, the position of the second and third coordinates were always changing. The position of the larva recorded by the computer is therefore an average.

The number of dots per row is dependent on the speed of the film and the speed of the stroboscope. The film speed, and hence the exposure time of each frame, varied over a 15-foot run of film because the movement of the film in the Bolex H16 camera is controlled by a spring. In addition, the film speed settings give only a guide of the film speed. The stroboscope provides an accurate time record, precise to within 1% of all scales. It was run at speeds of 19,400 flashes per minute (fpm), 42,000 fpm, and 25,000 fpm, to produce several dots per row. The more dots per row, the easier it is to analyse the film, both with respect to recognizing individual rows of dots and determining whether or not any particular row is suitable for measurement.

For any speed of stroboscope setting, the number of dots per row varied by 2 - 3 dots because of the variation of film speed over a 15-foot run. Movie film was taken at three settings: 12 frames per

second (fps), 24 fps, and 64 fps. Film taken at 12 fps has 9 - 12 dots per row; film taken at 24 fps has 4 - 6 dots per row; and film taken at 64 fps has 1 - 3 dots per row. When the film was analysed the distance between a constant number of dots was measured, 4 for 24 fps film and 8 for 12 fps film. There were too few dots per series in the 64 fps film for accurate analysis, so this film was not digitized.

Only rows of dots in focus and representing paths of aluminium flakes travelling parallel to the film were analysed. These latter are easily recognized because the distances between consecutive dots in any one row are constant. If the size and focus of the dots varies within a row, and distances between consecutive dots is not constant, then the flake of aluminium was not travelling parallel to the film, but either towards the film (if the dots are larger at the end of the row) or away from the film (if the dots are smaller at the end of the row). If the distances between consecutive dots vary within a row, and the dots are all of equal size, the velocity of the flake varied during the exposure time of the film. Because the size of the flakes varied over a wide range (15 - 308 μm in length, 15 - 231 μm in width, or 63% larger than 325 mesh), the dots varied in size from one row to another.

1.3. RESULTS

1.3.1. Behaviour of larvae with respect to water flow

1.3.1.1. Larval orientation

The typical posture of a black fly larva while filter-feeding

is shown in fig. 1.4. The larva is attached to the substratum at the posterior end of its abdomen, and the head is directed downstream. The thoracic proleg is held close to the body. The anal papillae, located on the dorso-posterior margin of the abdomen, are close to the substratum and contained within the boundary layer (sect. 1.3.1.3., 1.3.2.1.). The larva has rotated longitudinally about 160° , and the ventral surface of the thorax and head is directed upwards. The ventral surface of the larva is identified by the ventral nerve cord and ganglia, visible through the ventral abdominal wall.

The larva has a streamlined shape. The body is hemicylindrical and widens at the fifth abdominal segment. The widest part of the body is therefore a short distance behind the upstream end of the body, a feature characteristic of maximally streamlined shapes (Shapiro 1961, Alexander 1973). The fans are held out away from the body.

The angle of deflection is that angle a larva is deflected by the current from an axis perpendicular to the substratum and originating at the site of attachment (insert, fig. 1.5.). This angle is dependent on the rate of water flow. The regression of angle of deflection on the logarithm of rate of water flow is significant (F no. for linear regression = 85.23, P^{***} ¹). The angle increases linearly with the logarithm of rate of water flow (fig. 1.5.).

¹ Throughout thesis, P^* denotes a probability of 0.05 or less; P^{**} , a probability of 0.01 or less, and P^{***} , of 0.001 or less.

FIG. 1.4. PHOTOGRAPH OF A LARVA OF SIMULIUM VITTATUM.
DIRECTION OF FLOW FROM LEFT TO RIGHT. (MAG. X 7)

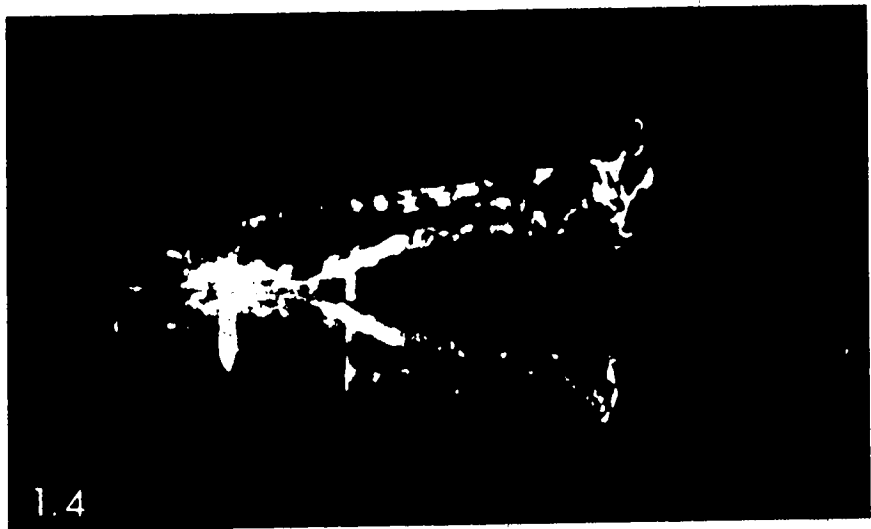

②

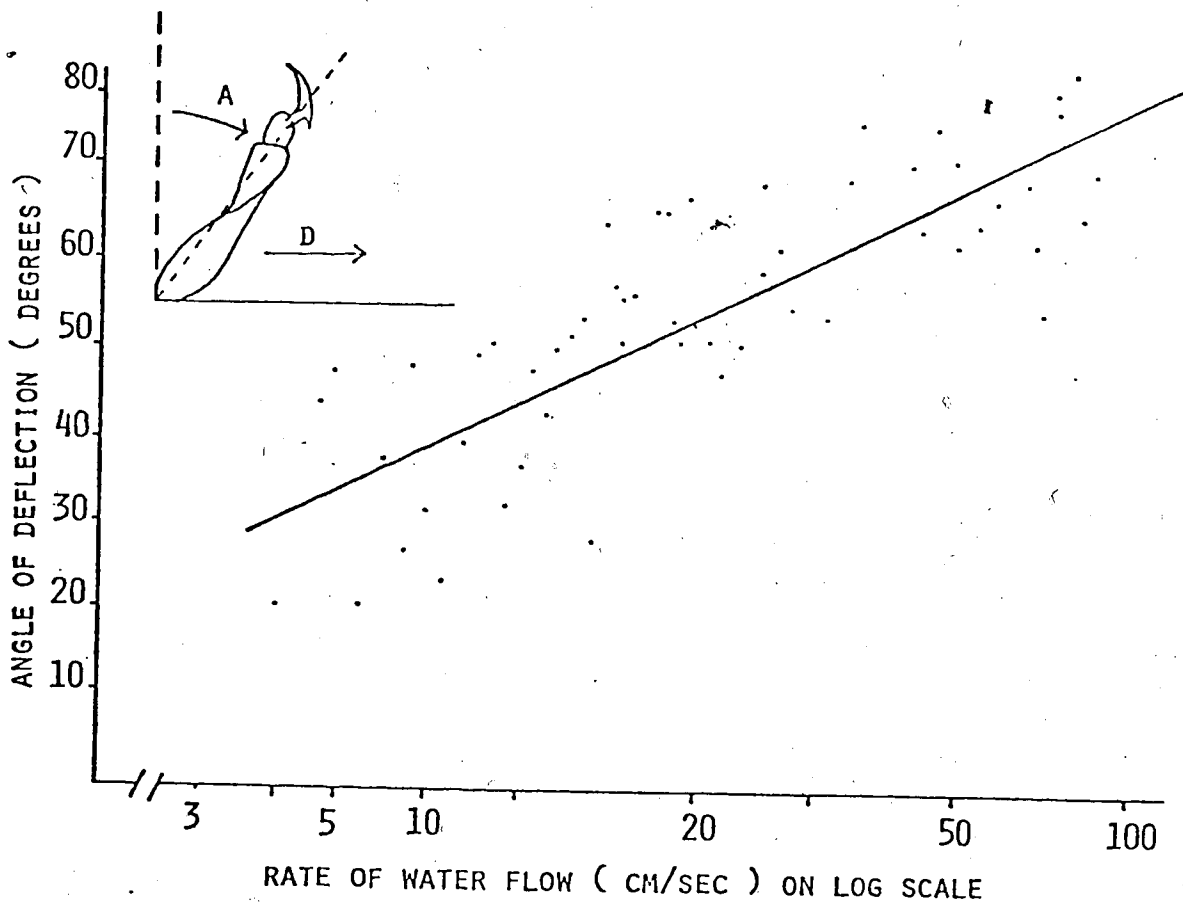

FIG. 1.5. ANGLE OF DEFLECTION OF LARVAE OF SIMULIUM VITTATUM PLOTTED AGAINST RATE OF WATER FLOW. (INSERT: A = ANGLE OF DEFLECTION, D = DIRECTION OF WATER FLOW).

The angle of deflection increases as the square of the rate of flow and represents a balance between the force of the current and the resistance of the larval body.

The amount a larva is deflected varies with the size of larva. The angle of deflection was determined for larvae in 4 feeding experiments¹ (sect.2), and in one of these (#12) the size of each larva was noted. The mean angle of deflection for 5 medium larvae, 34.2 ± 4.5 degrees, is significantly greater (P*) than that for 5 large larvae, 26.4 ± 9.1 , degrees when the larvae were exposed to a rate of water flow of 5.45 cm/sec. Because of the gradient of velocity near the substratum, larger larvae are exposed to faster average rates of flow.

As the rate of water flow increases, the larval head is brought closer to the substratum. In faster flowing water, the boundary layer is thinner and larvae can filter with their fans closer to the substratum. In fig. 1.6., the heights above the substratum of larval head fans are given (in parentheses) with angles larvae were deflected, plotted against the rate of water flow.

In order to consider the hydrodynamics of larvae in a flow of water, the Reynold's Number for black fly larvae was calculated. The calculation was made as follows:

¹ Readings taken during the feeding experiments are not included in the regression analysis of angle of deflection on rate of water flow because rate of water flow of the feeding experiments was measured with a hot film flowmeter. This provides flow measurement at one point, not averaged over a depth of water flow.

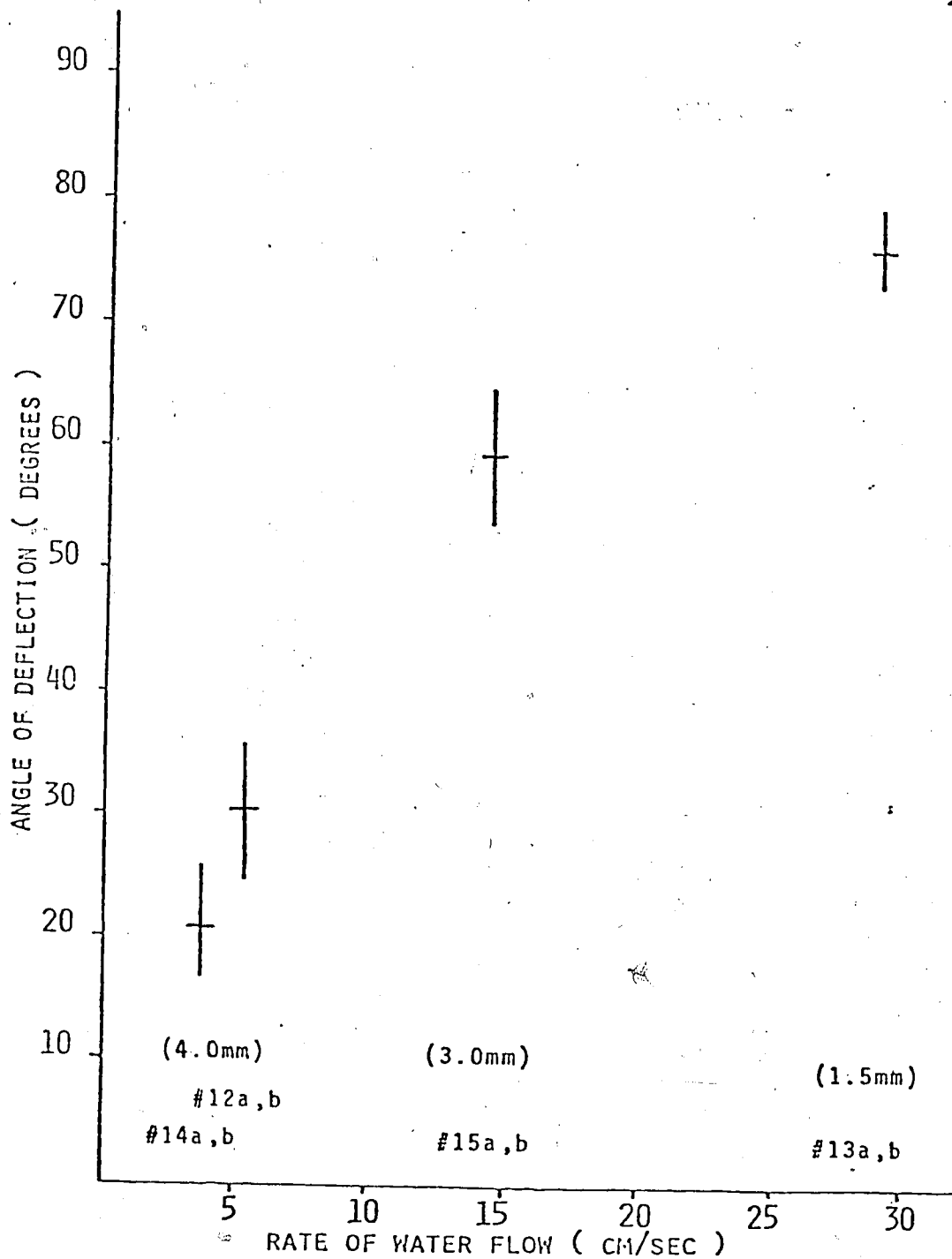

FIG. 1.6. MEAN ANGLE OF DEFLECTION OF A LARVA OF SIMULIUM VITIATUM AND HEIGHT OF LARVAL FANS ABOVE THE SUBSTRATUM PLOTTED AGAINST RATE OF WATER FLOW. (VERTICAL LINES = SD OF MEANS, HEIGHT LARVAL FANS INDICATED IN PARENTHESES, # = NUMBER OF EXPERIMENT (SEE PART 2 OF THESIS).)

$$R = \rho \mu a / \eta$$

where R is the Reynold's Number;
 'ρ' is the density of water, taken as 0.99973 gm/cm³ at 4C; 'μ' is the rate of water flow, taken as 3 cm/sec - 80 cm/sec, the range of water flow to which larvae are normally exposed in natural watercourses;
 'a' is the length of the larva in the direction of flow and calculated here for larval lengths of 5 - 9 mm (and an angle of deflection of 20 - 80 degrees); 'η' is the viscosity of the medium taken here as 0.01346 poise for water at 9C and 0.01307 poise for water at 10C.

The Reynold's Number for black fly larvae ranges from 19 - 5,200. It is important in relation to the force of drag larvae must withstand (sect. 1.4.1.). Since 'a' is dependent on the angle of deflection of the larvae, it is also dependent on 'μ', the rate of water flow.

1.3.1.2. Flow profiles around larvae

Profiles of water flow around larvae are shown in figs. 1.17. Figs. 1.7 - 1.11 are composite tracings taken from 16 mm cinefilm of two-dimensional views (figs. 1.12 - 1.14 and sect. 1.3.2.1.). The direction of flow is from left to right. The straight lines represent paths of aluminium flakes which travelled parallel to the film. The irregular shapes are tracings of paths of aluminium flakes which are represented on the film by blurred streaks. These flakes did not travel parallel to the film and are predominate in areas of turbulent flow and in the boundary layer.

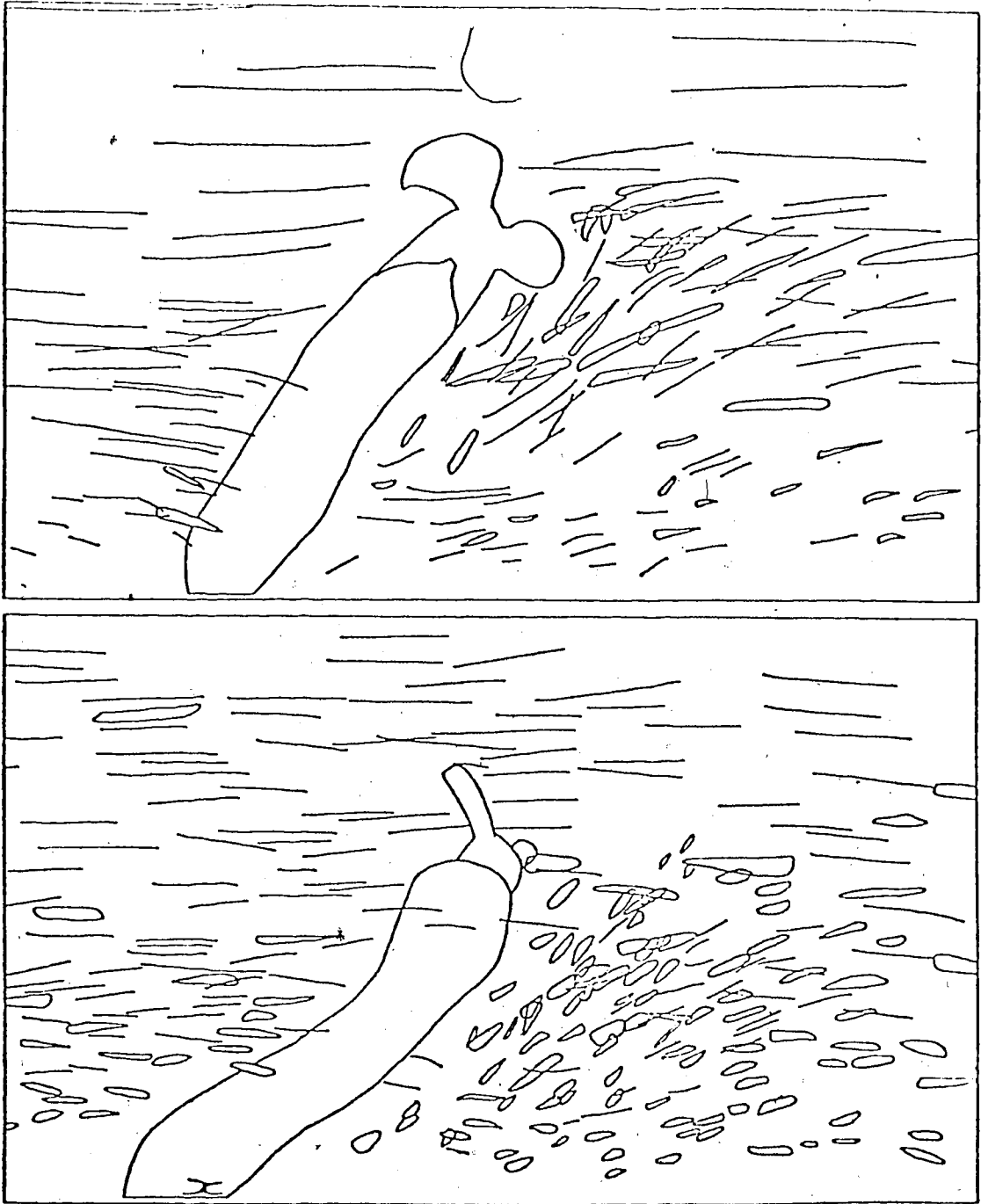

FIG. 1.7. (TOP). TWO-DIMENSIONAL FLOW PROFILE AROUND A LARVA OF *SIMULIUM VITTATUM* WHILE FILTERING AND ROTATED LESS THAN 180 DEGREES. LATERAL VIEW.
 FIG. 1.8. (BOTTOM). TWO-DIMENSIONAL FLOW PROFILE AROUND A LARVA OF *SIMULIUM VITTATUM* WHILE FILTERING AND ROTATED APPROXIMATELY 90 DEGREES. LATERAL VIEW. IN BOTH FIGS, FLOW IS FROM LEFT TO RIGHT.

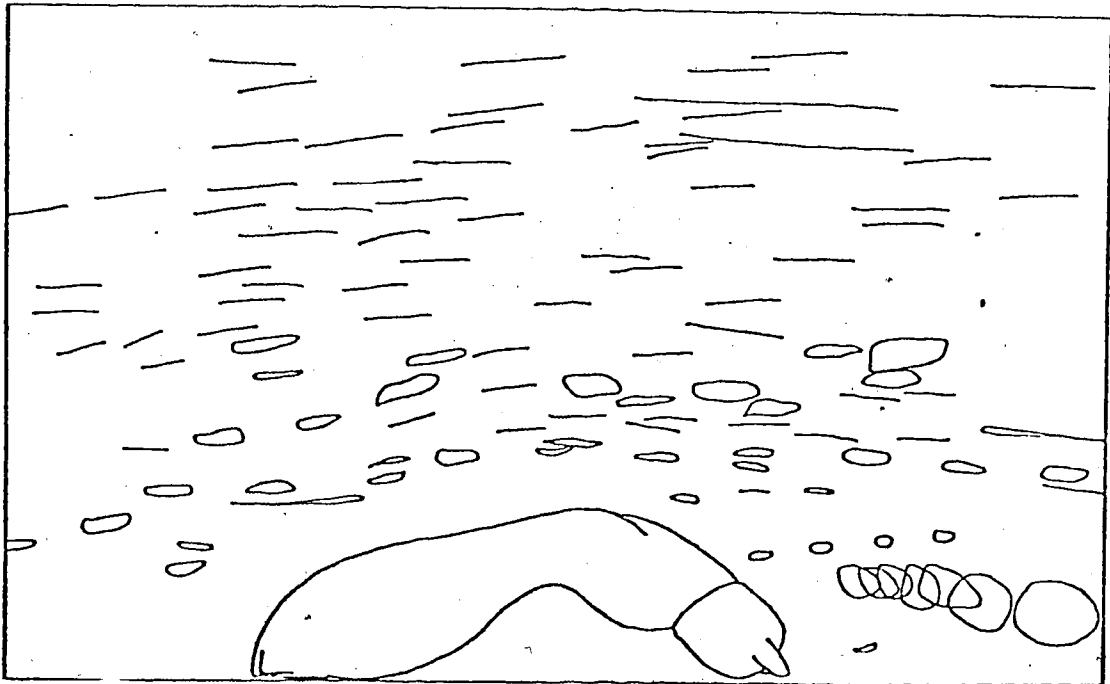
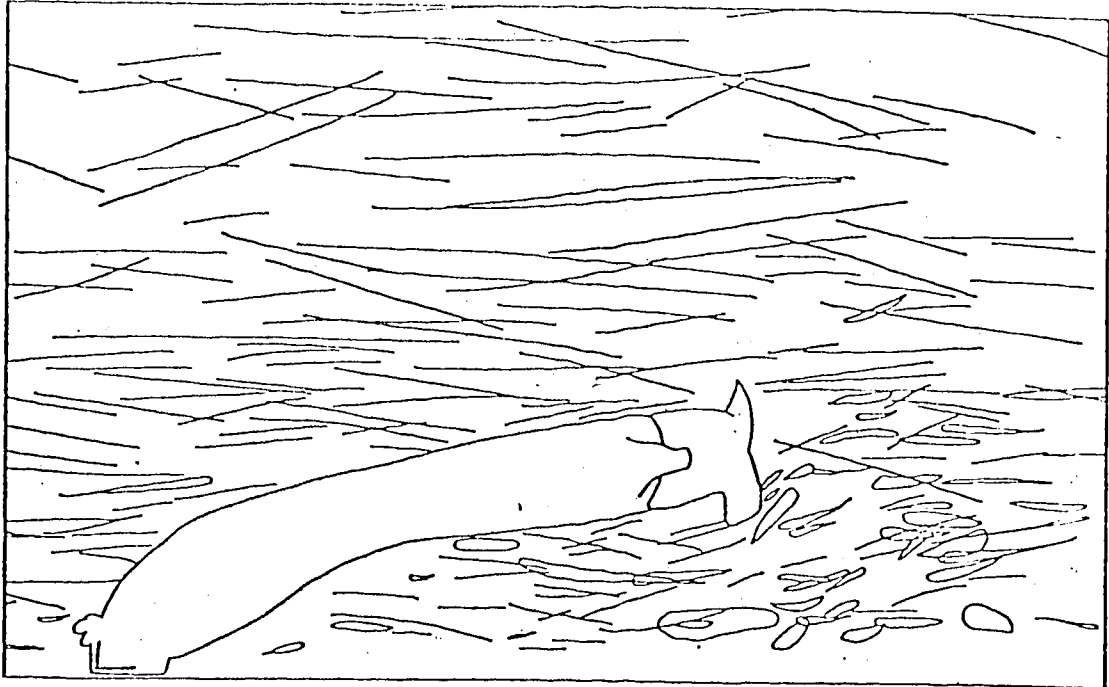

FIG. 1.9. (TOP). TWO-DIMENSIONAL FLOW PROFILE AROUND A LARVA OF *SIMULIUM VITTATUM* WHILE FILTERING AND ROTATED APPROXIMATELY 90 DEGREES. LATERAL VIEW. (RATE OF WATER FLOW FASTER THAN IN PROFILES 7 AND 8.)

FIG. 1.10. (BOTTOM). TWO-DIMENSIONAL FLOW PROFILE AROUND A LARVA OF *SIMULIUM VITTATUM* WHILE 'CROUCHING'. LATERAL VIEW. IN BOTH FIGS FLOW IS FROM LEFT TO RIGHT.

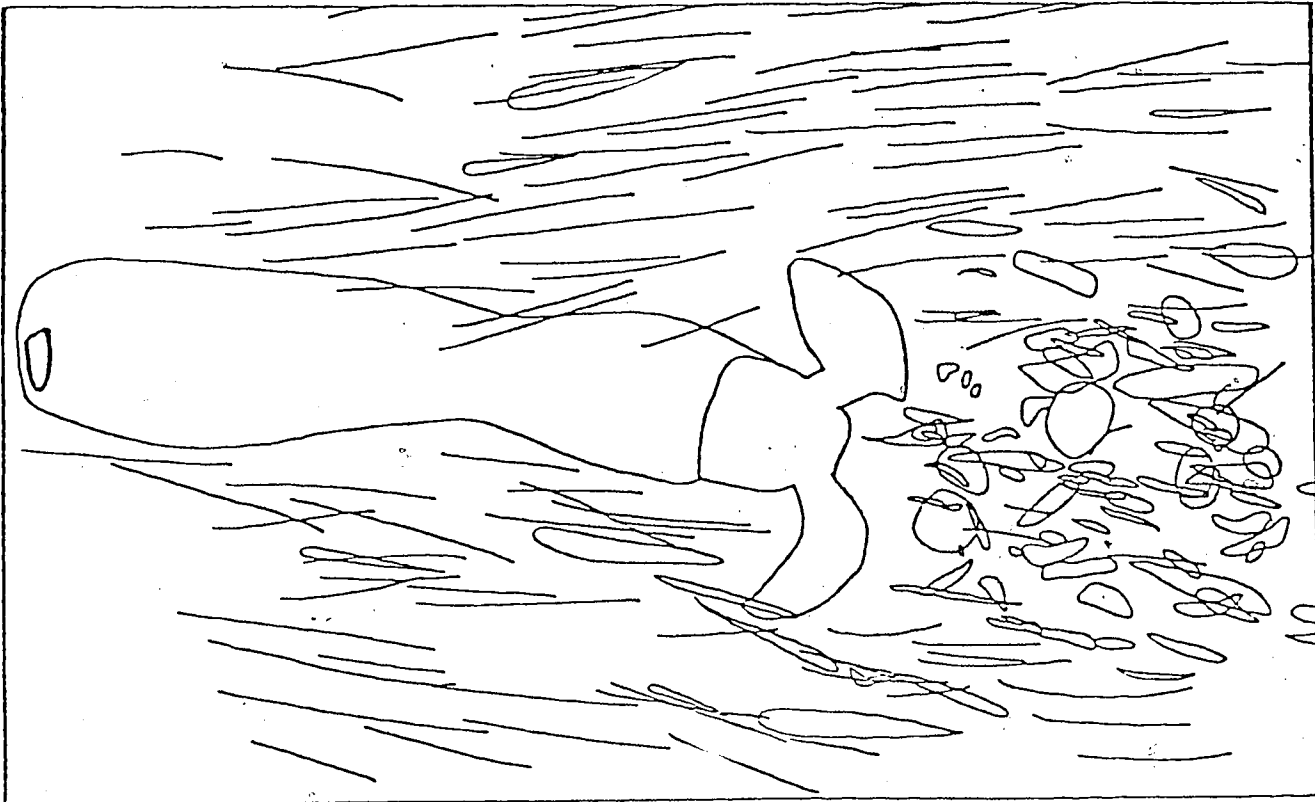

FIG. 1.11. TWO-DIMENSIONAL FLOW PROFILE AROUND A LARVA OF SIMULIUM VITTATUM WHILE FILTERING. DORSO-VENTRAL VIEW, FLOW IS FROM LEFT TO RIGHT.

The gradient of increasing velocity with height above the substratum is demonstrated in figs. 1.7 - 1.10 with the paths of aluminium flakes increasing in length above the substratum. Water flow in the flume is not laminar, and this is reflected in variation in length and direction of individual streaks at the same height above the substratum. Flow close to the substratum is reduced and, owing to the larva, tends to be turbulent.

Few paths of aluminium flakes are recorded in the immediate vicinity of the substratum (figs. 1.7 - 1.9, 1.12, 1.13), because slow flow in the boundary layer carried few flakes there. Occasionally, flakes settled to the substratum and rolled along the substratum (fig. 1.12).

A second boundary layer, one around the base of a larva, is demonstrated clearly in fig. 1.16. This photograph is of a larva attached to the side wall of the flume with its body extending towards the centre of the flume. The boundary layer is recognized by absence of streaks representing paths of aluminium flakes. It is 0.5 mm thick. The rate of water flow 1 mm away from the larva is 12.4 cm/sec. A small area of turbulence is demonstrated underneath the larva and immediately downstream from the site of attachment.

The cinefilm tracings show two areas of turbulence around larvae. Flow is disrupted by its passage around the larvae (figs. 1.7, 1.8) and through the larval cephalic fans (figs. 1.7, 1.9, 1.11). The turbulence downstream from the larval body has a general upward direction, and is an example of eddy formation downstream from obstacles

FIG. 1.12. PHOTOGRAPH OF A FILTERING LARVA OF SIMULIUM VITTATUM IN A WATER FLOW. (REPHOTOGRAPHED FROM A 16 MM CINEFILM, FILMED AT 12 FPS, WITH A STROBE SPEED OF 25,000 RPM) (MAG. X 6). FOR FIGS. 1.12 - 1.14., DIRECTION OF FLOW IS FROM LEFT TO RIGHT. WHITE DOTS REPRESENT PATHS TRAVELLED BY FLAKES OF ALUMINIUM DURING EXPOSURE TO THE FILM.

FIG. 1.13. PHOTOGRAPH OF A LARVA OF SIMULIUM VITTATUM WHILE 'CROUCHING' IN A WATER FLOW. (SPECIFICATIONS AS IN FIG. 1.12.)

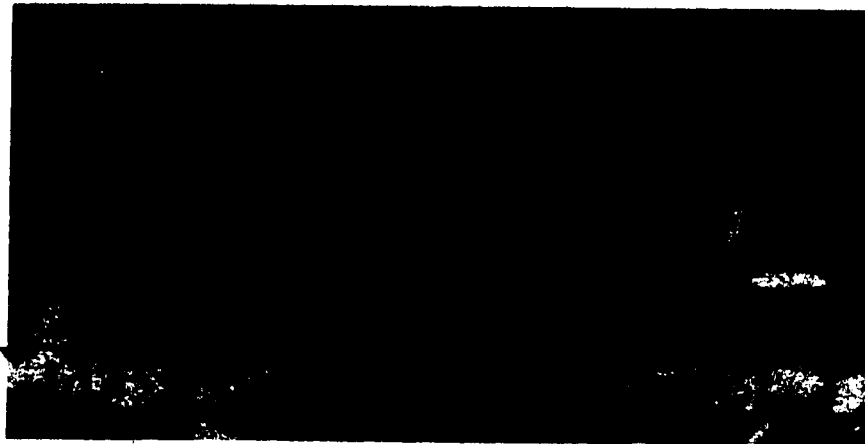
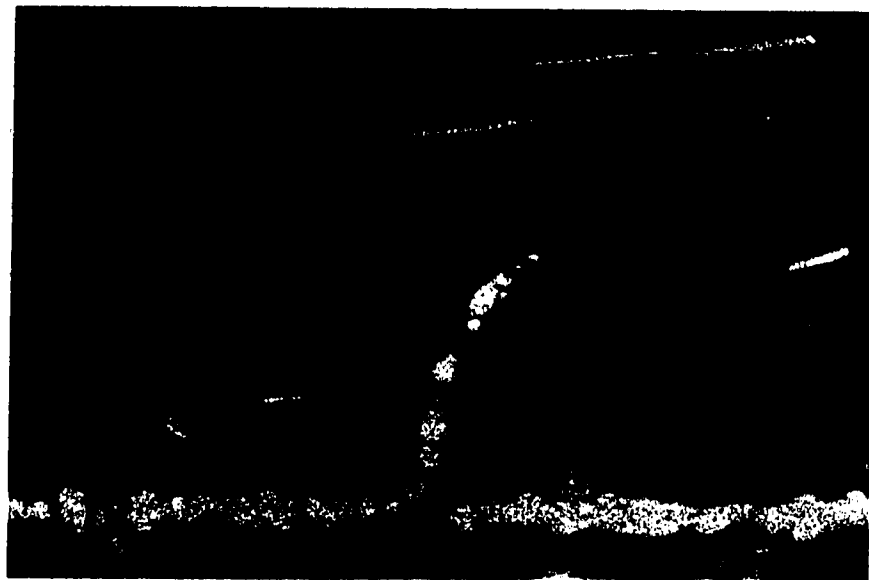

FIG. 1.14. PHOTOGRAPH OF A LARVA OF SIMULIUM VITTATUM ATTACHED TO A WALL OF A FLUME AND IN A WATER FLOW. (MAG. X 7.5) (SPECIFICATIONS AS IN FIG. 1.12.)

FIG. 1.15. PHOTOGRAPH OF A FILTERING LARVA OF SIMULIUM VITTATUM (INDICATED BY ARROW) AND PRISM IMAGE OF LARVA (AT LEFT) IN A WATER FLOW. DIRECTION OF FLOW IS FROM BOTTOM TO TOP OF PAGE. (REPHOTOGRAPHED FROM A 16 MM CINEFILM, FILMED AT 24 FPS, WITH A STROBE SPEED OF 19,4000.) (MAG. ACTUAL IMAGE X 4, PRISM IMAGE X 3.5)

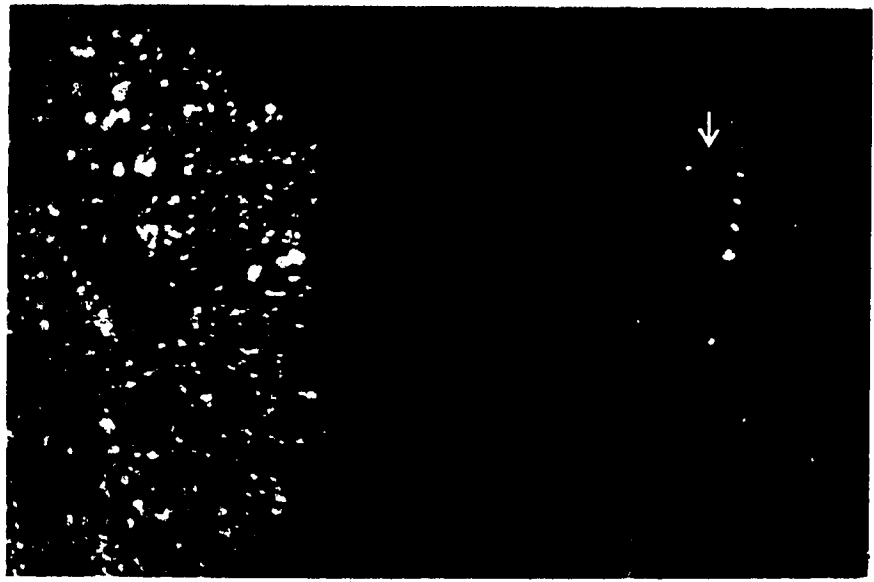
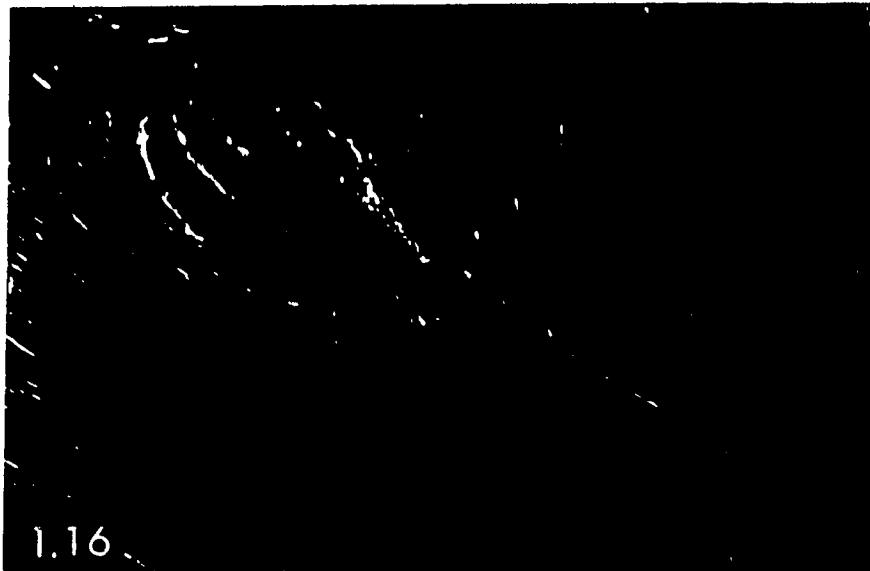

FIG. 1.16. PHOTOGRAPH OF A LARVA OF SIMULIUM VITTATUM IN A WATER FLOW AND BOUNDARY LAYER AROUND LARVAL BODY. DIRECTION OF FLOW IS FROM UPPER LEFT TO LOWER RIGHT. WHITE STREAKS REPRESENT PATHS TRAVELLED BY FLAKES OF ALUMINIUM DURING EXPOSURE OF FILM (ILLUMINATED BY TWO HIGH INTENSITY LIGHTS). (MAG. X 6).

FIG. 1.17. PHOTOGRAPHS OF A FILTERING LARVA OF SIMULIUM VITTATUM IN A WATER FLOW. FIG. 1.17A, LARVA WITH ONE FAN EXTENDED' FIG. 1.17B, LARVA WITH BOTH FANS RETRACTED. DIRECTION OF FLOW IS FROM UPPER LEFT TO LOWER RIGHT. WHITE STREAKS REPRESENT PATHS TRAVELLED BY FLAKES OF ALUMINIUM DURING EXPOSURE OF FILM (ILLUMINATED BY FLASH). (MAG. X 7).



1.16



1.17a

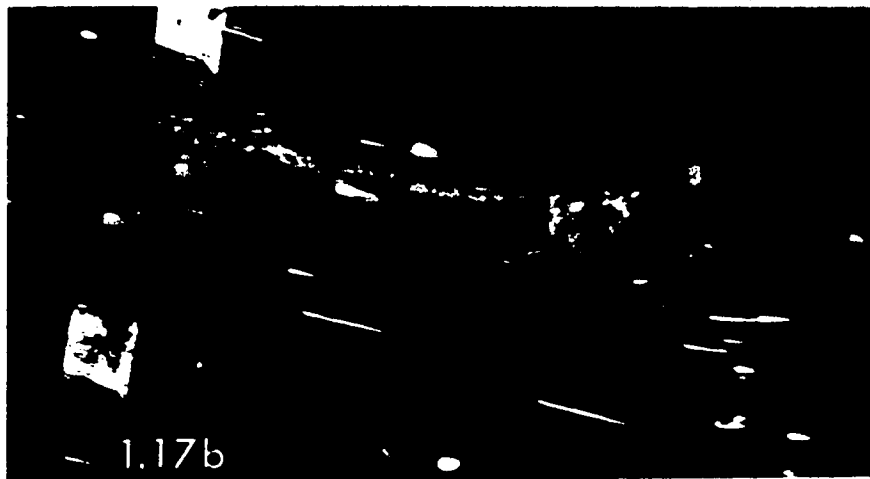

1.17b

in the flow.

Turbulence created by the flow of water through the fans is also illustrated in the photographs of fig. 1.17. The larva in fig. 1.17 was photographed while attached to the tailgate of the flume (fig. 1.1). The dorsal surface of the abdomen is shown and the larva has rotated itself approximately 110° . This photograph was taken with a flash and hence paths of aluminium flakes are represented as tapering streaks.

1.3.1.3. Avoidance reaction

The avoidance reaction of black fly larvae is illustrated in figs. 1.10, 1.13. The larva has pulled itself down towards the substratum, but has not attached to the substratum with its proleg. Larvae rarely make a second attachment unless they are exposed to very fast rates of flow.

In the flow profile illustrated in fig. 1.10, the crouching larva is exposed to slower water flow than the filter-feeding larvae (sect. 1.3.2.1.). Turbulence occurs immediately downstream from the larva.

1.3.2. Velocity profiles around larvae

1.3.2.1. Two-dimensional profiles

Velocity profiles around larvae were calculated from digitized measurements of aluminium paths taken from 16 mm cinefilms

of larvae in the flume. Vector diagrams of velocity profiles around larvae are presented in figs. 1.18 - 1.21. Lateral profiles (figs. 1.18 - 1.20) were taken from cinefilms of larvae attached to a form close to the side wall of the flume (figs. 1.12; 1.13). A dorso-ventral profile (fig. 1.21) is taken from a cinefilm of a larva attached to the side wall of the flume (fig. 1.14). The velocity profiles are referred to in the text by the numbers of the figures illustrating them, for example, fig. 1.18 illustrates velocity profile #18.

In all velocity profiles, orientation of vectors indicates direction of flow, and length of vectors, the rate of flow. The position of the larva is indicated by a dotted outline. In lateral profiles, the X-axis represents the substratum.

Each vector is a mean of all readings recorded in a particular area of the computer-defined grid. In this preliminary investigation the standard error of the means of these vectors was not calculated. For more comprehensive studies this information can be extracted from the data after modification of the computer programme.

Two lateral velocity profiles were analysed using filter-feeding larvae. Figs. 1.18 and 1.19 are vector diagrams of flow around each larva when nearby flow was 11.9 and 14.3 cm/sec respectively, as measured with a midjet current meter (table 1.1). The angle of deflection for each larva is 58° and 40° , respectively.

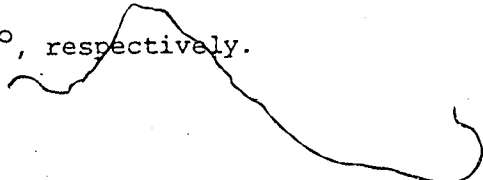

Table 1.1. Rates of water flow (cm/sec) recorded using a midget current meter and vectors for two and three-dimensional vector profiles around a larva of *Simulium vittatum*. Angles of deflection of larva are included.

Profile	Current meter (cm/sec)	Range of vectors (cm/sec)	Angle of deflection (degrees)
2-d			
18	11.9	3.0 - 11.8	58
19	14.3	1.3 - 6.9	40
20	14.3	3.0 - 9.5	-
21	14.3	4.4 - 12.2	-
3-d			
22	29.6	31.0 - 46.4	70
23	20.4	5.2 - 18.5	75

With the exception of the length of the vectors, profiles #18 and #19 (figs. 1.18 and 1.19) are very similar because the orientation of vectors is determined by the mainstream of flow. Differences occur in areas of turbulence downstream from the larva. In profile #19, turbulence is demonstrated immediately downstream from the larval body and around the larval head; in #18, it is demonstrated downstream from the larval head. Vectors in these areas are shorter (recording a flow reduction of approximately 2 cm/sec) and are oriented in a direction different from those representing the mainstream.

The increase of velocity with increase in height above the substratum is clearly demonstrated. The boundary layer is also represented, although only by a few vectors. In velocity profile #18 (fig. 1.18) the boundary layer velocity ranged from 3.03 - 7.97 cm/sec. At the

FOR FIGS. 1.18 - 1.21 (TWO-DIMENSIONAL VECTOR PROFILES), NUMBERS ABOVE EACH VECTOR RECORDS NUMBERS OF READINGS USED IN CALCULATION OF THAT VECTOR. VECTORS ARE CENTERED AT THE MIDPOINT OF COORDINATES FORMING THE GRID. IF NO ALUMINIUM FLAKES WERE RECORDED FROM ANY AREA, NO VECTOR IS CALCULATED AND THE AREA IS MARKED BY A SINGLE DOT. POSITION OF LARVA (INDICATED BY DOTTED LINES) IS ESTIMATED USING LARVAL COORDINATES (*). BL = FLOW WITHIN BOUNDARY LAYER, * = AVERAGE POSITION OF LARVAL COORDINATES (SEE TEXT). DISTANCE ALONG SUBSTRATUM IS RELATIVE TO LARVAL SITE OF ATTACHMENT (0.0CM), + AND - INDICATING DOWNSTREAM AND UPSTREAM FROM LARVA RESPECTIVELY.

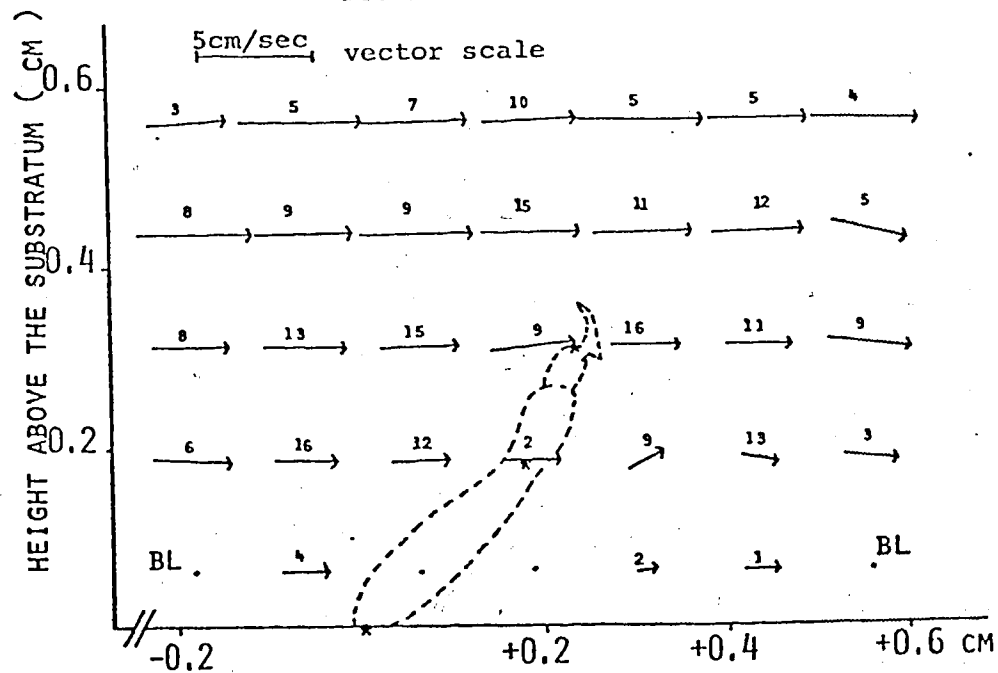
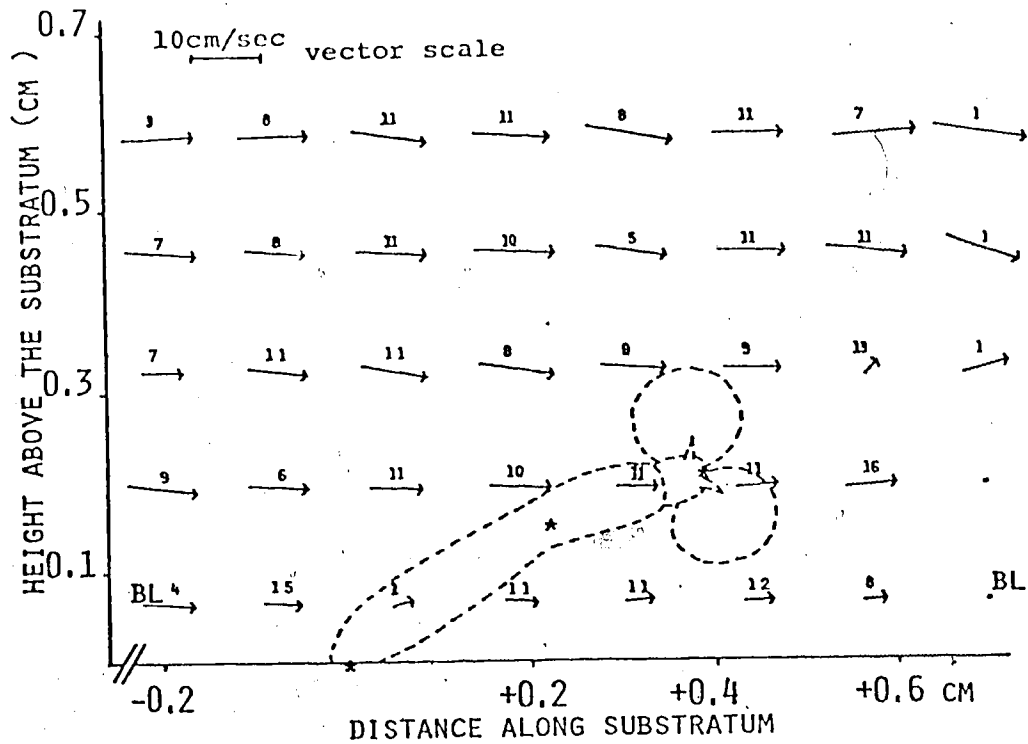

FIG.1.18. (TOP). MEAN VELOCITY VECTORS AT SELECTED COORDINATES ABOUT A FILTERING LARVA OF *SIMULIUM VITTATUM*, WHILE EXPOSED TO 'FASTER' WATER FLOW, LATERAL VIEW.

FIG.1.19. (BOTTOM). MEAN VELOCITY VECTORS AT SELECTED COORDINATES ABOUT A FILTERING LARVA OF *SIMULIUM VITTATUM*, WHILE EXPOSED TO 'SLOWER' WATER FLOW, LATERAL VIEW.

level where the larvae filter, approximately 2.5 mm above the substratum, flow ranged from 8.0 - 11.0 cm/sec. At 6 mm above the substratum, flow ranged from 9.9 - 14.2 cm/sec.

Velocity profile #19 (fig. 1.19) is slower than #18, although the rate of flow as measured by a midget current meter was 2.5 cm/sec faster (table 1.1). Again, there are few vectors in the boundary layer; these range in flow from 1.2 - 2.7 cm/sec. Rate of flow of water filtered by the larva ranged from 4.5 - 6.2 cm/sec. At 6 mm above the substratum, flow was 4.5 - 6.9 cm/sec, more than double that in the boundary layer.

A velocity profile around a larva exhibiting an avoidance reaction (sect. 1.2.2.3) is shown in fig. 1.20. The larva has pulled itself down within the boundary layer. Velocity in the boundary layer is represented by only three vectors, which range from 2.9 - 5.1 cm/sec. This vector profile is faster than #19, although larvae were exposed to the same water flow during filming. Rate of water flow to which larval fans would have been exposed if the larva had been filtering ranges from 4.5 - 6.9 cm/sec. Flow 6 mm above the substratum ranged from 7.6 - 9.0 cm/sec.

A 2-d dorso-ventral velocity profile around a filter-feeding larva is shown in fig. 1.21. The larva is oriented with its head directed downstream and towards the bottom of the flume. It was attached to the side wall of the flume 2 cm below the surface of the water and 0.13 cm above the form (sect. 1.2.3.).

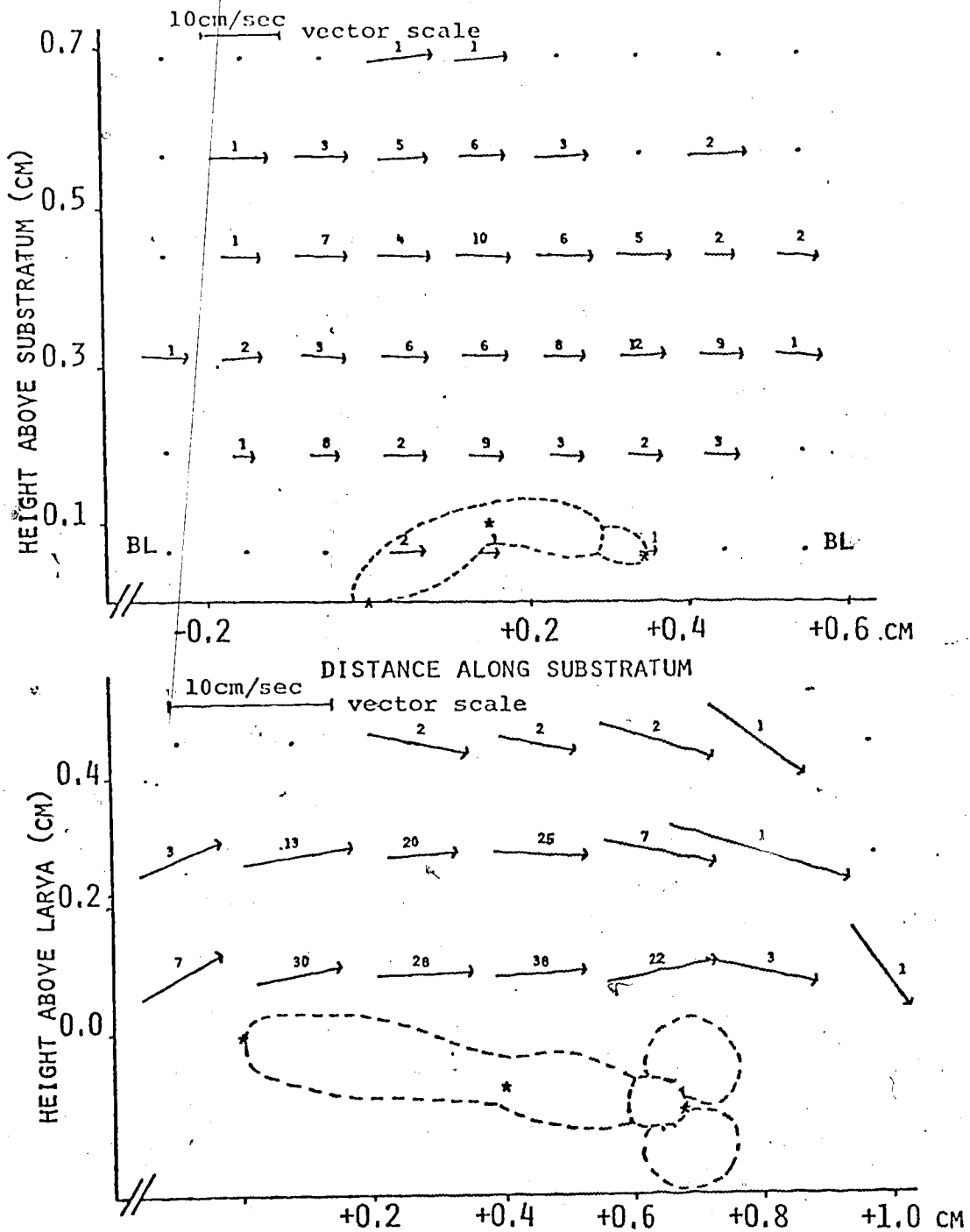

FIG. 1.20.(TOP). MEAN VELOCITY VECTORS AT SELECTED COORDINATES ABOUT A LARVA OF *SIMULIUM VITTATUM* WHILE 'CROUCHING'. LATERAL VIEW.

FIG. 1.21.(BOTTOM). MEAN VELOCITY VECTORS AT SELECTED COORDINATES ABOUT A FILTERING LARVA OF *SIMULIUM VITTATUM*. DORSO-VENTRAL VIEW.

Because of the pattern of water flow in the flume, very few flakes of aluminium passed below the larva and no vectors were calculated for this area.

The rate of water flow 1 cm away from the larva was 14.3 cm/sec, as measured by a midget current meter. The pattern of flow is directed around the larva. There is no gradient of velocities over the distance of 4.6 mm in height above the larva.

1.3.2.2. Three dimensional profiles

Three dimensional profiles are taken from cinefilms of a larva and its prism image (fig. 1.15). Vector diagrams for two 3-d velocity profiles around filtering larvae are presented in figs. 1.22 and 1.23. The format of the diagrams is the same as that of the 2-d velocity profiles with the following exceptions:

- 1) Profiles L and D are simultaneous lateral (L) and dorso-ventral (D) views of the same larva. The lateral view is the prism image of D; the 'actual' image.
- 2) Because there are too many vectors in each 3-d profile to include on one page, these vector profiles are subdivided into parts (three, four, and two for figs. 1.22, 1.23a, 1.23b, respectively). The parts of each profile are denoted by Roman capital numbers, for example, 1.22I, 1.22II, 1.22III, which together represent 3-d profile #22.
- 3) Vectors occurring at different heights above the substratum are distinguished by different types of lines (see height code).

- 4) Numbers above vectors record numbers of readings used in the calculation of any vector. Vectors with no numbers above them are based on one reading (Appendix A).
- 5) Areas in which no vectors were recorded are marked with a single dot.
- 6) The X-axis represents the substratum, and is oriented parallel to the bottom of the flume and the direction of the mainstream. The Y-axis is perpendicular to the bottom of the flume and the direction of the mainstream, and is parallel to the side wall of the flume. It represents the vertical axis and height above the larva. The Z-axis is perpendicular to the side wall of the flume and the direction of the mainstream, and represents the direction across the width of the flume.

Profiles are referred to in the text by the number of the figure illustrating them, for example, profile #22 is illustrated by fig. 1.22. Two vector diagrams of the same velocity profile, #23, are presented as parts a and b of fig. 1.23. The vector diagram shown in fig. 1.23a is analysed with different coordinates than that in fig. 1.23b. Diagram #23a has a coordinate interval of 1.0 mm originating at 0.5 mm; #23b has a coordinate interval of 2.0 mm originating at 0.0 mm. Vector diagram #22 has the same coordinate interval as #23a.

The velocity profile #22 was filmed at 24 fps; #23, at 12 fps. The rate of water flow measured with a midget current meter was 29.6 cm/sec for #22 and 20.4 cm/sec for #23. The larvae were deflected 70° and 75° , respectively.

FOR FIGS 1.22 - 1.23A,B (THREE-DIMENSIONAL VECTOR PROFILES),
VIEW L = LATERAL VIEW, VIEW D = DORSO-VENTRAL VIEW, X - AXIS
= DIRECTION OF FLOW, FROM LEFT TO RIGHT; Y - AXIS = HEIGHT
ABOVE THE SUBSTRATUM; Z - AXIS = DISTANCE ACROSS WIDTH OF
FLUME. VECTORS ARE REPRESENTED BY STRAIGHT LINES CODED
ACCORDING TO THEIR HEIGHT (MM) ABOVE THE SUBSTRATUM. NUMBERS
ABOVE VECTORS RECORD NUMBERS OF READINGS USED IN CALCULATION
OF THAT VECTOR. VECTORS WITHOUT NUMBERS ARE BASED ON ONE
READING. VECTORS ARE CENTERED AT THE MIDPOINT OF COORDINATES
FORMING THE GRID. IF NO ALUMINIUM FLAKES WERE RECORDED IN
ANY AREA, NO VECTOR IS CALCULATED AND THE AREA IS MARKED BY
A SINGLE DOT. POSITION OF LARVA (INDICATED BY DOTTED LINES)
IS ESTIMATED USING AVERAGE POSITION OF LARVAL COORDINATES (*)
(SEE TEXT).

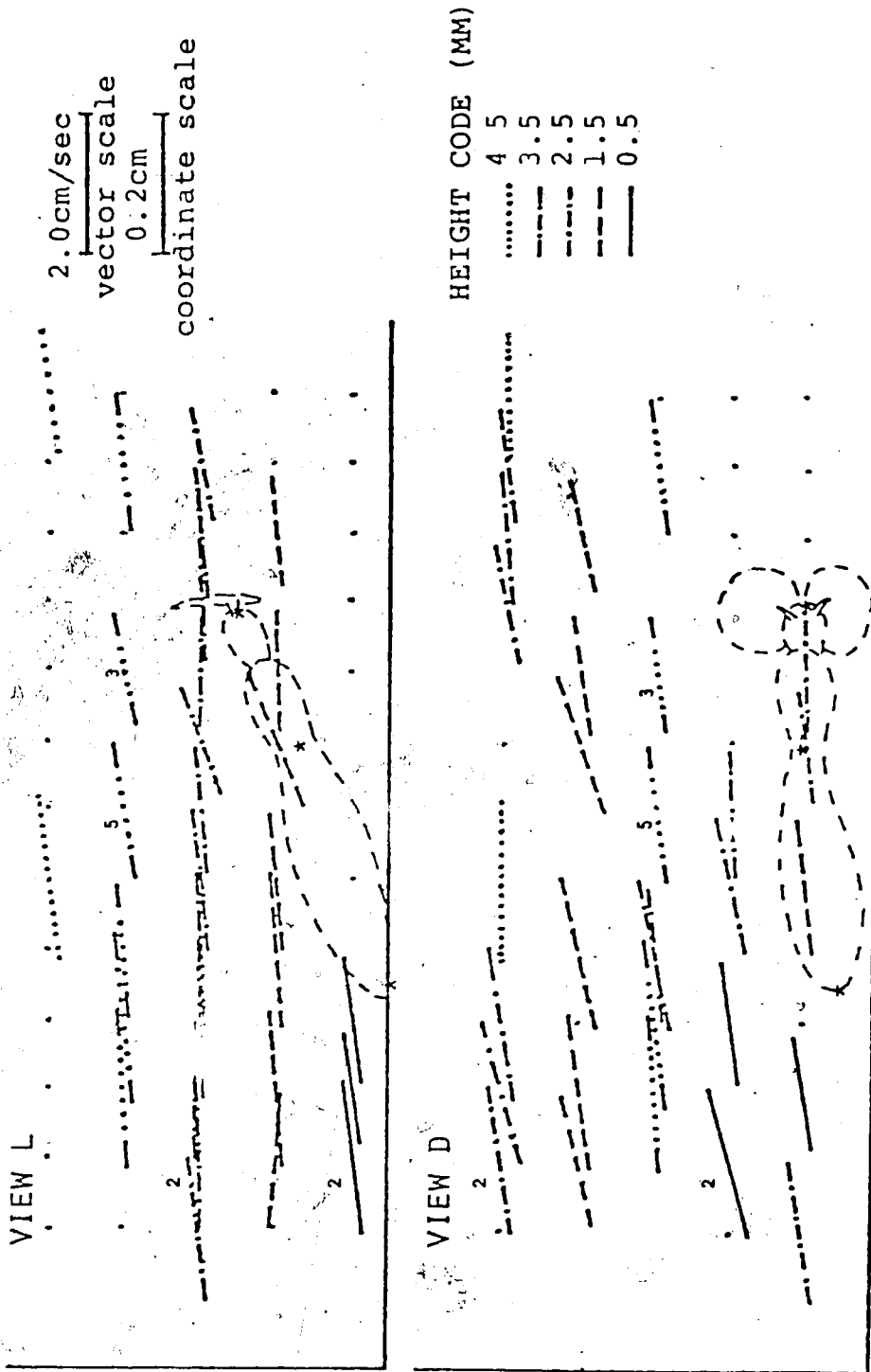

Y - AXIS

Z - AXIS

X - AXIS

FIG. 1.221 (OF PARTS I, II, III), MEAN VELOCITY VECTORS AT SELECTED COORDINATES ABOUT A LARVA OF SIMULIUM VITTIATUM. THREE-DIMENSIONAL PROFILE WITH A COORDINATE INTERVAL OF 1.0MM.

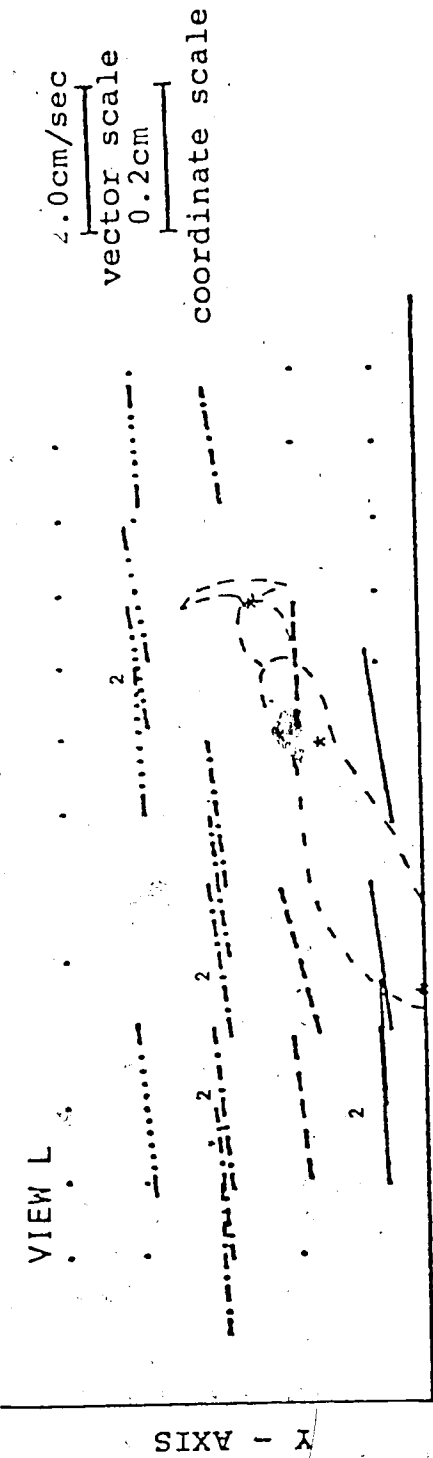

GH1 CODE (MM)

.....	4.5
-----	3.5
- - - - -	2.5
- - - - -	1.5
—————	0.5

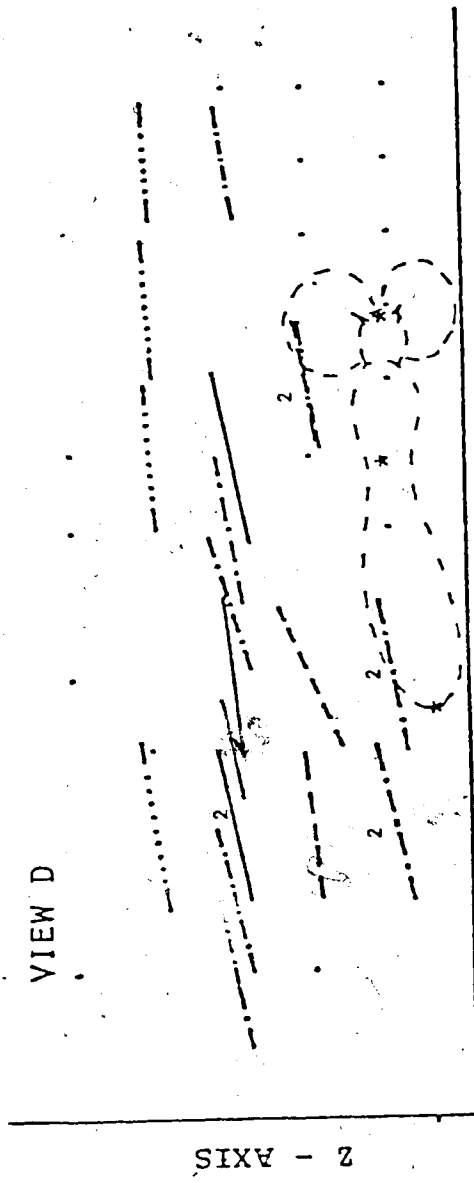

X - AXIS

FIG. 1.22II (OF PARTS I, II, III). MEAN VELOCITY VECTORS AT SELECTED COORDINATES ABOUT A LARVA OF SIMULIUM VITTATUM, THREE-DIMENSIONAL PROFILE WITH A COORDINATE INTERVAL OF 1.0MM.

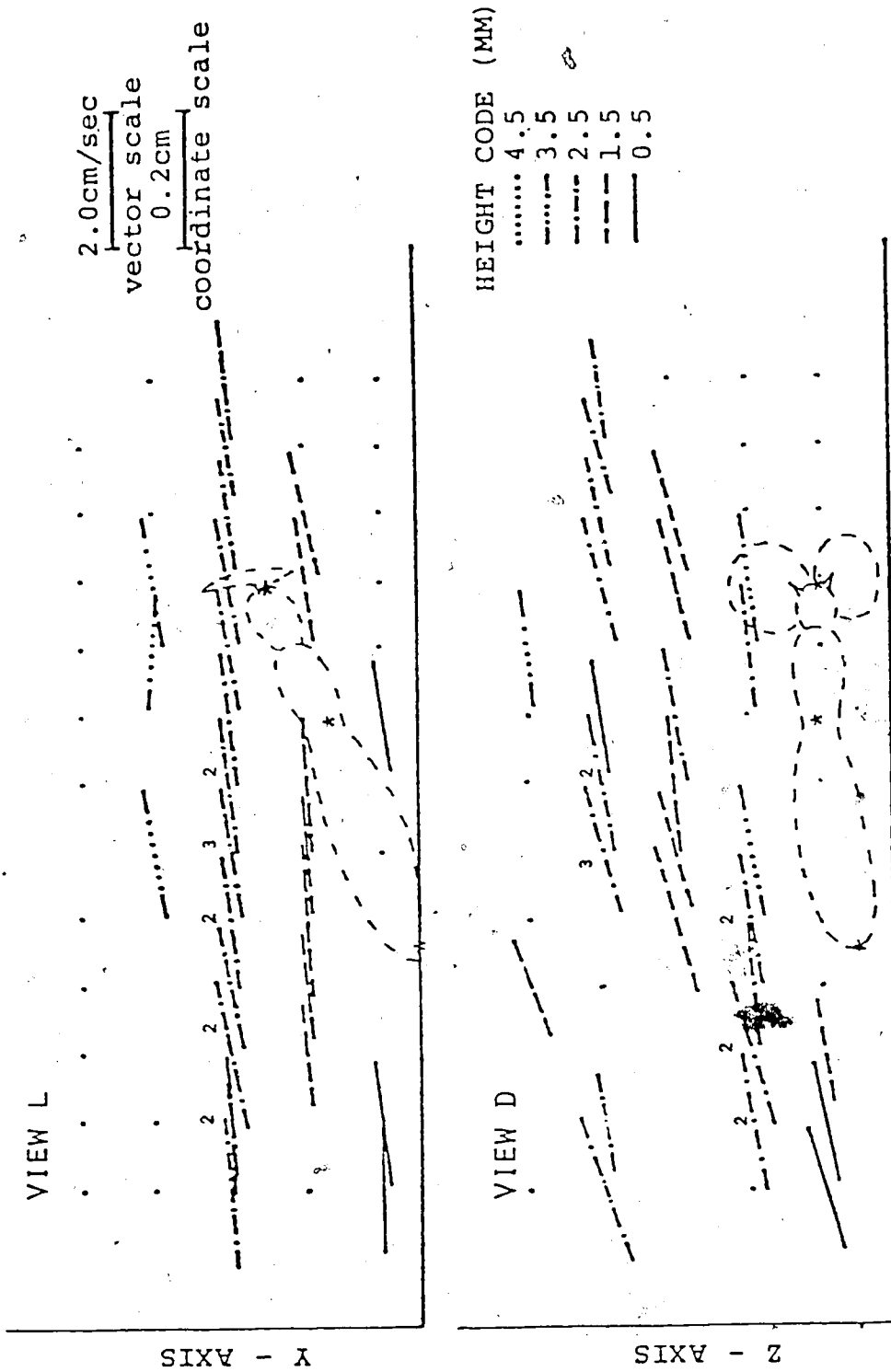
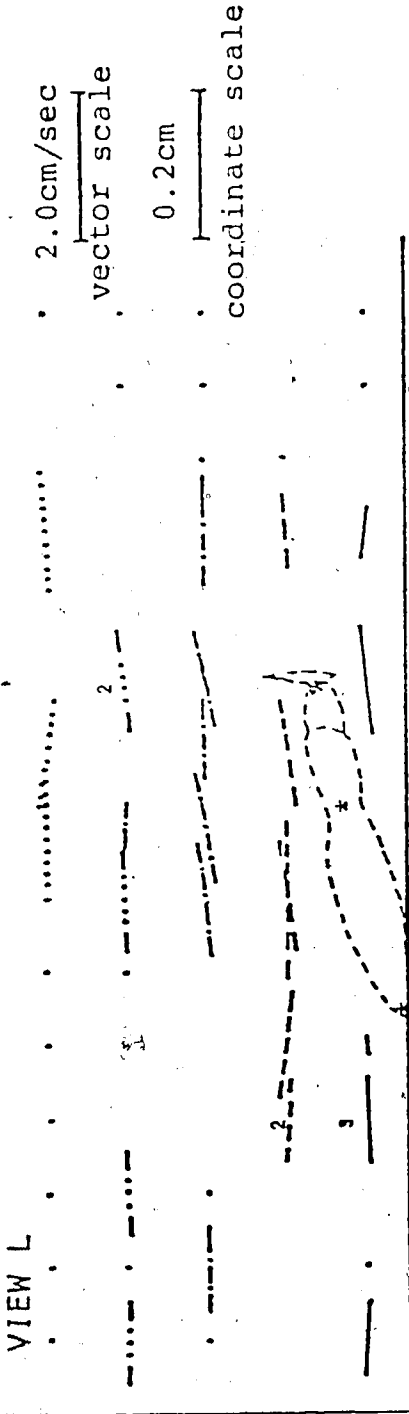
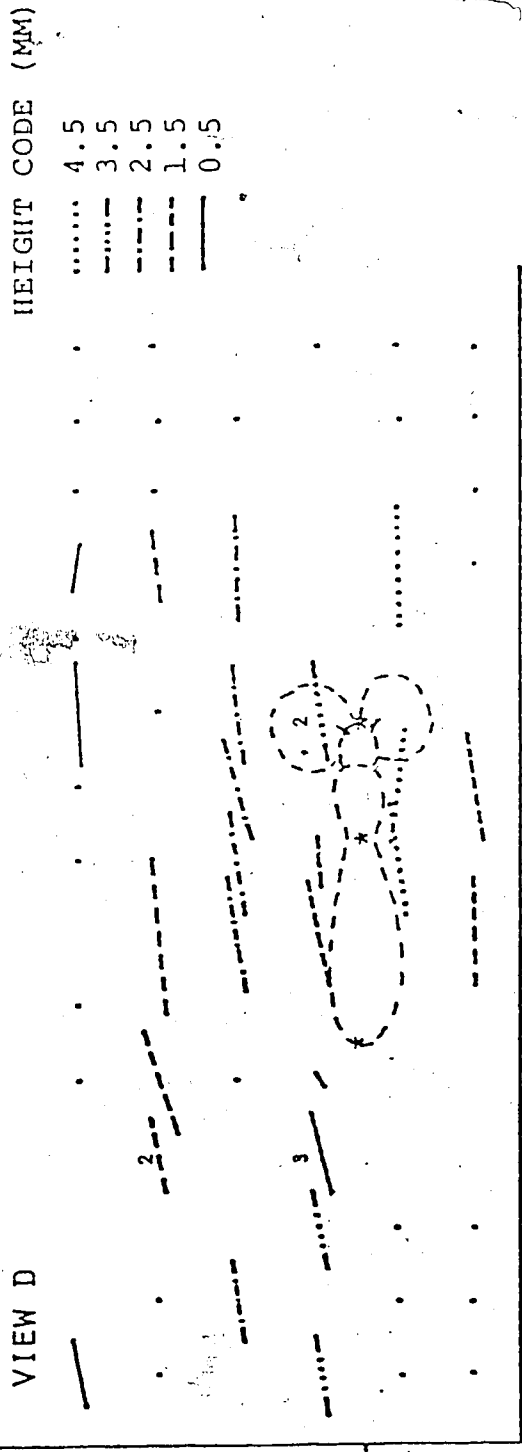

FIG. 1.22III (OF PARTS I, II, III). MEAN VELOCITY VECTORS AT SELECTED COORDINATES ABOUT A LARVA OF SIMULIUM VITTIATUM. THREE-DIMENSIONAL PROFILE WITH A COORDINATE INTERVAL OF 1.0MM.



Y - AXIS



Z - AXIS

FIG. 1.23A (OF PARTS I, II, III, IV). MEAN VELOCITY VECTORS AT SELECTED COORDINATES ABOUT A LARVA OF SIMULIUM VITATUM. THREE-DIMENSIONAL PROFILE WITH A COORDINATE INTERVAL OF 1.0MM.

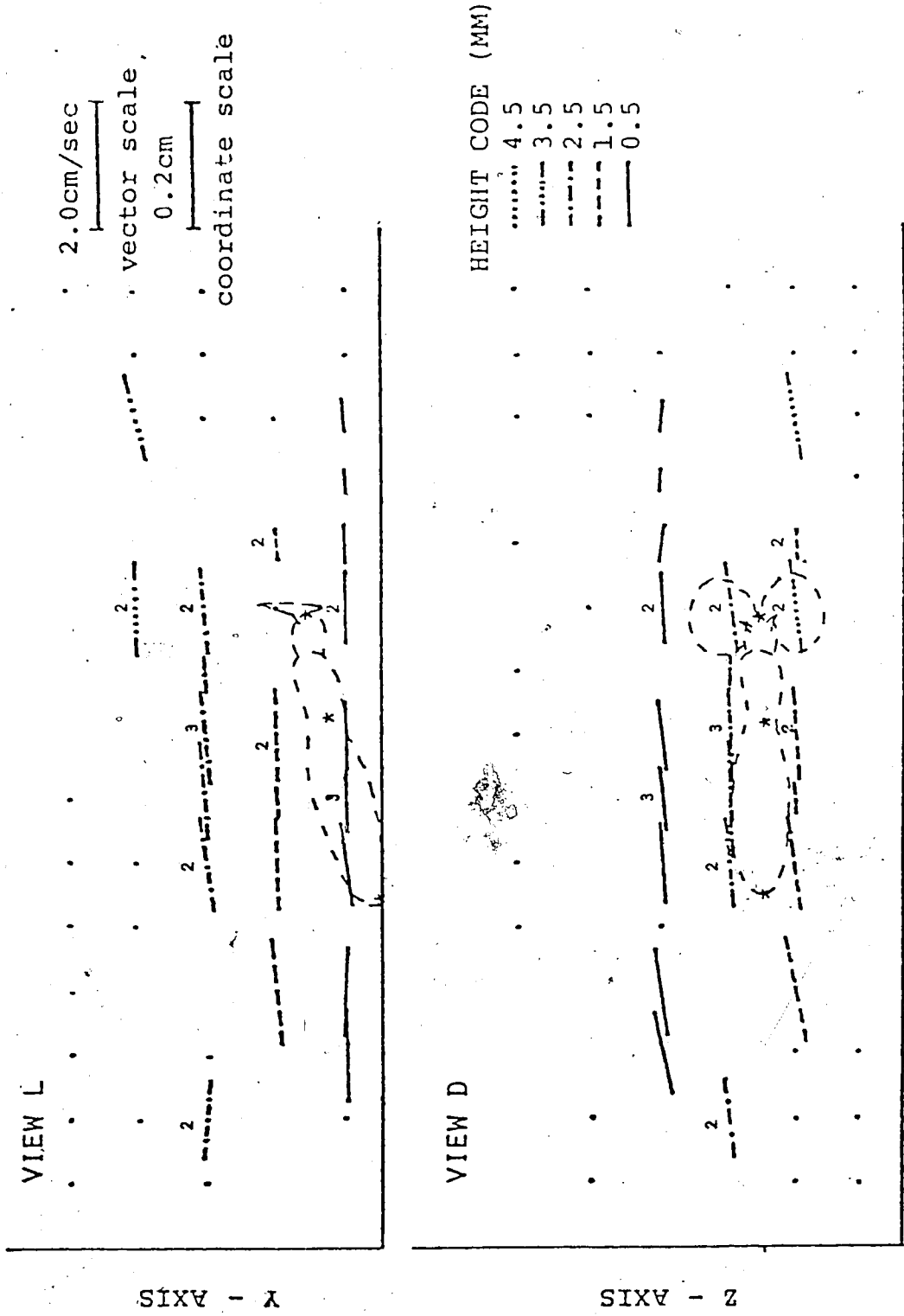

FIG. 1.23AII (OF PARTS I, II, III, IV). MEAN VELOCITY VECTORS AT SELECTED COORDINATES ABOUT A LARVA OF SIMULIUM VITTIATUM. THREE-DIMENSIONAL PROFILE WITH A COORDINATE INTERVAL OF 1.0MM.

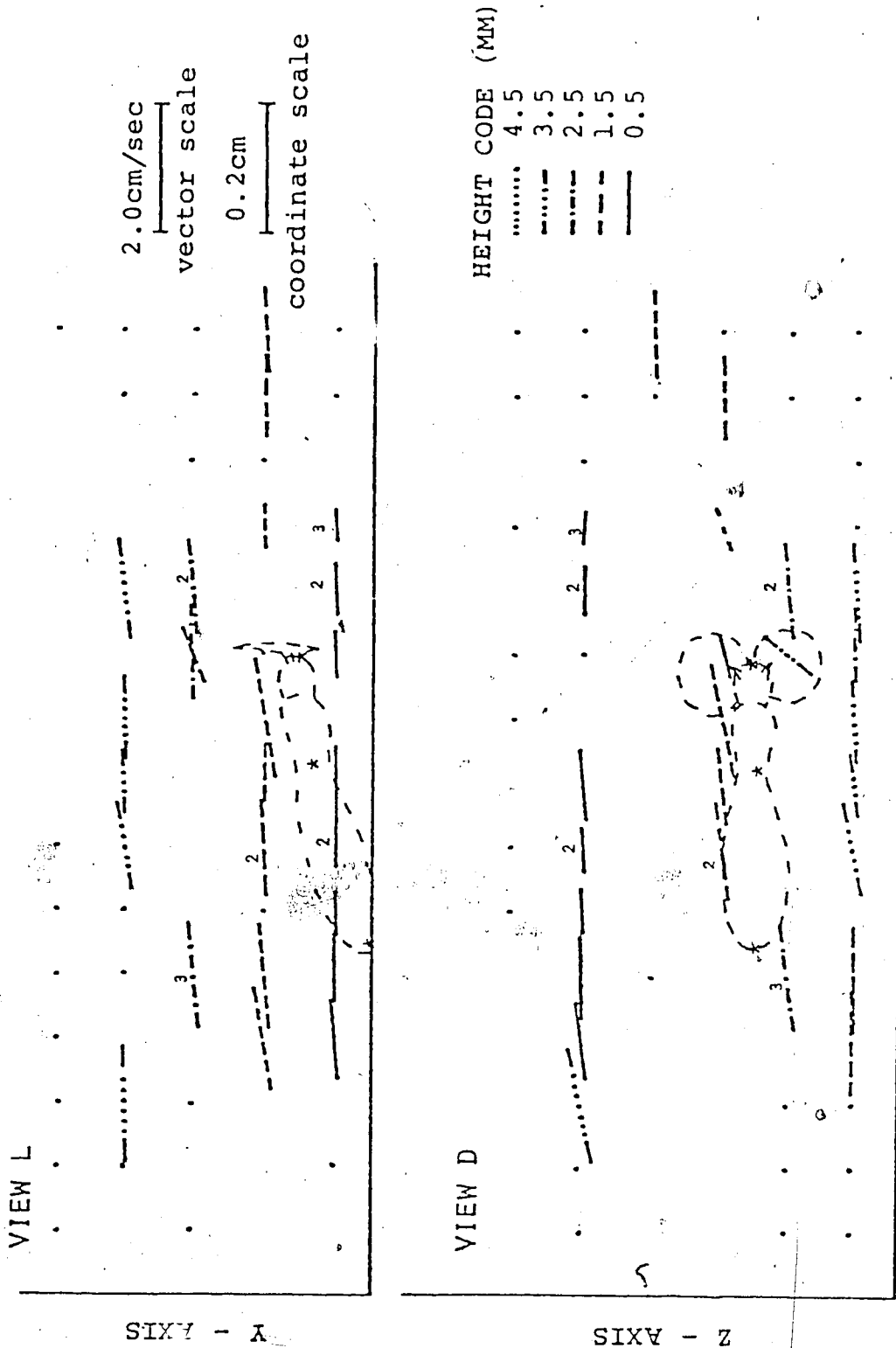

FIG. 1.23AIII (OF PARTS I, II, III, IV). MEAN VELOCITY VECTORS AT SELECTED COORDINATES ABOUT A LARVA OF SIMULIUM VITTIATUM, THREE-DIMENSIONAL PROFILE WITH A COORDINATE INTERVAL OF 1.0MM.

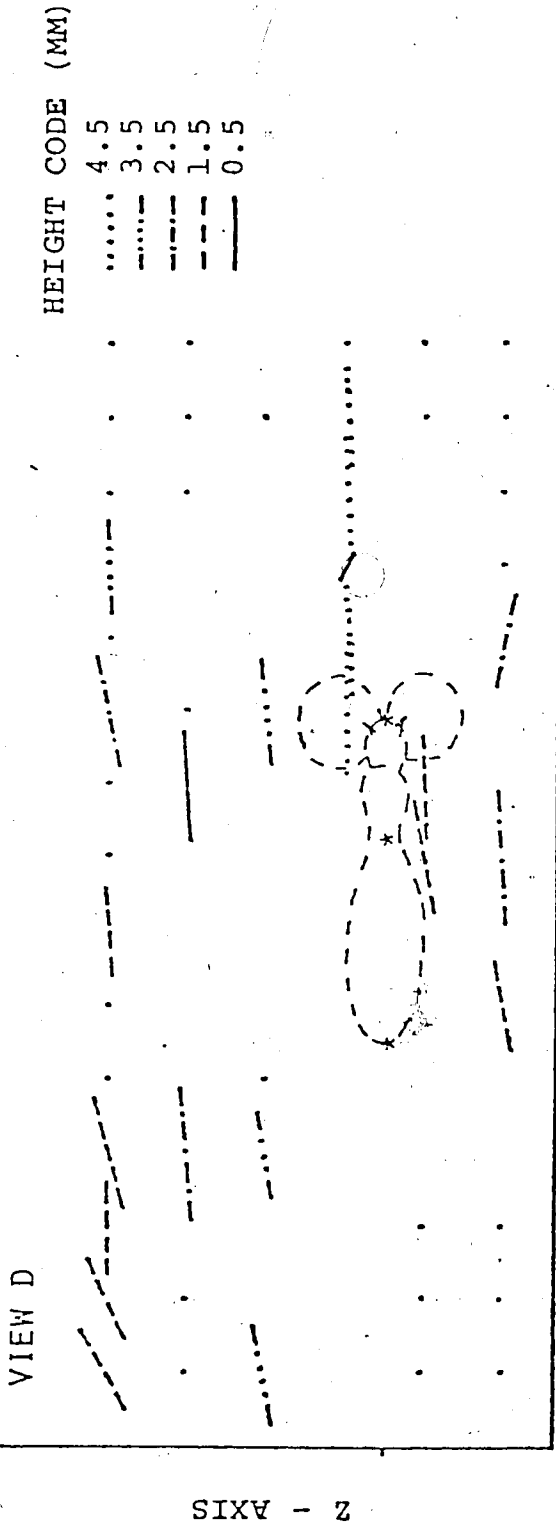
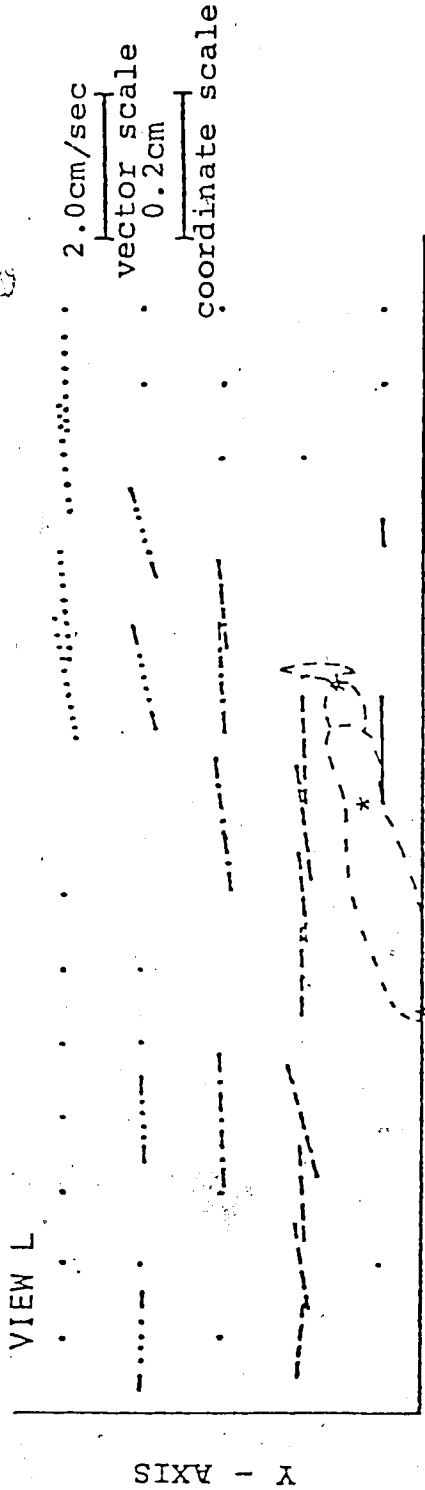

FIG. 1.23AIV (OF PARTS I, II, III, IV). MEAN VELOCITY VECTORS AT SELECTED COORDINATES ABOUT A LARVA OF SIMULIUM YITTIATUM, THREE-DIMENSIONAL PROFILE WITH A COORDINATE INTERVAL OF 1.0MM.

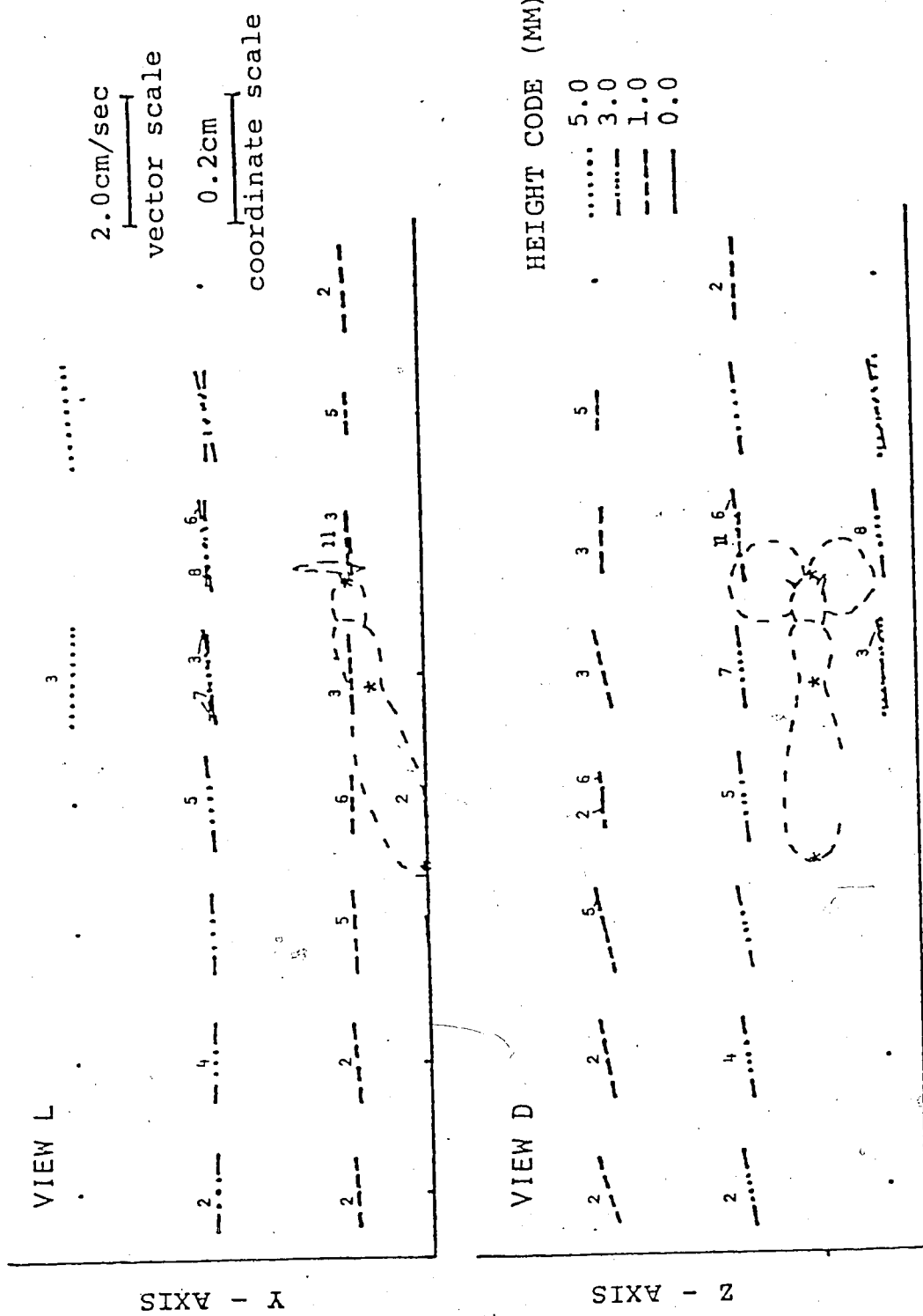

FIG. 1.23B I (OF PARTS I, II). MEAN VELOCITY VECTORS AT SELECTED COORDINATES ABOUT A LARVA OF *SILPHIUM VITTIATUM*. THREE-DIMENSIONAL PROFILE WITH A COORDINATE INTERVAL OF 2.0MM.

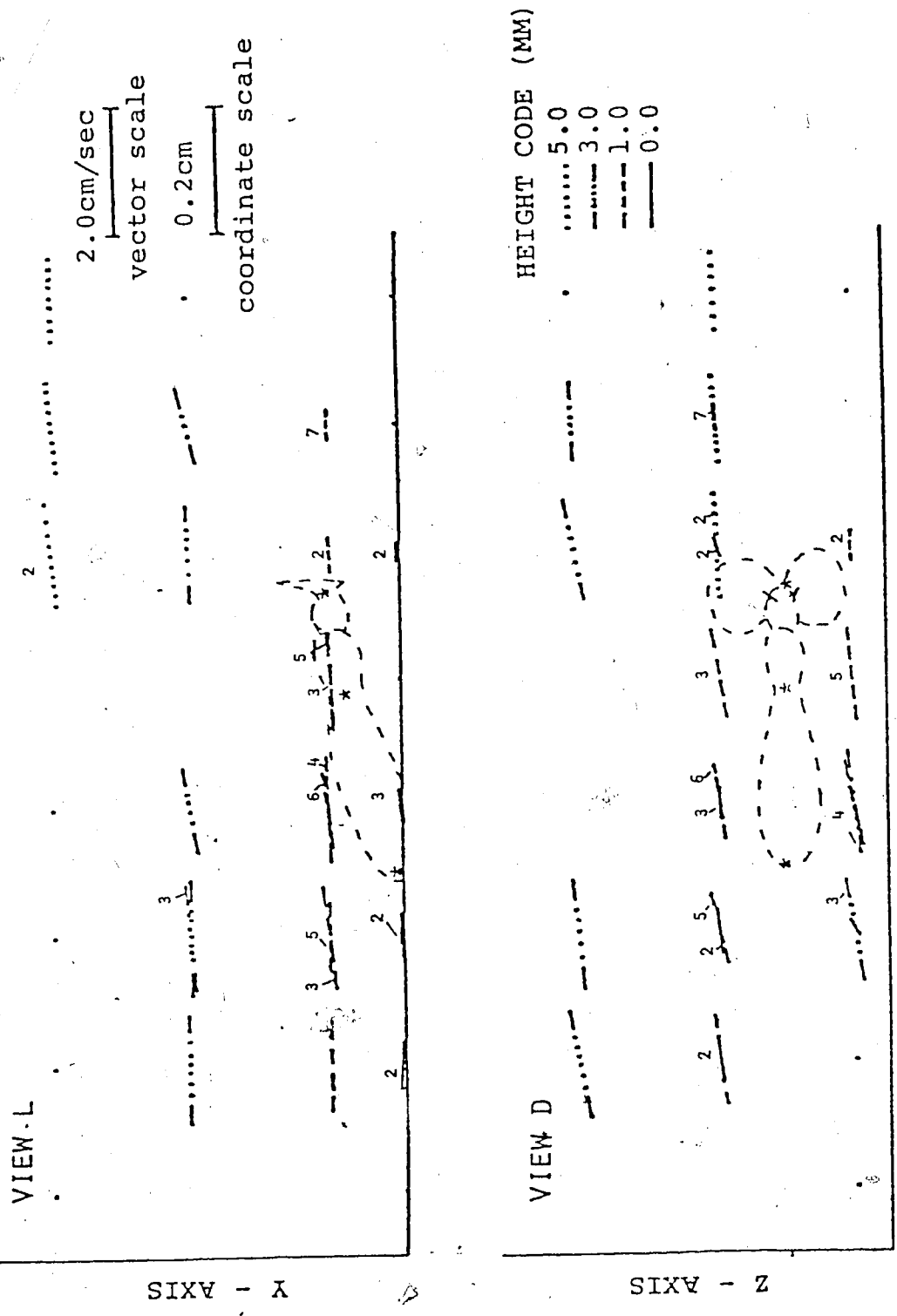

FIG. 1.23BII (OF PARTS I, II). MEAN VELOCITY VECTORS AT SELECTED COORDINATES ABOUT A LARVA OF SIMULIUM VITTIATUM. THREE-DIMENSIONAL PROFILE WITH A COORDINATE INTERVAL OF 2.0MM.

Velocity profile #22 is faster than #23 (table 1.1). The vectors of profile #22 are not distributed as uniformly as those of #23. Those vectors which occur close to the substratum occur at some distance to one side of the larva, and those close to the larva on the Z-axis are above the larva. The velocity gradient and boundary layer are not well represented.

In velocity profile #23, the vectors are distributed on both sides of the larva in the D view. The velocity gradient is well represented. Vectors are recorded from the boundary layer, however, most vectors within 1 mm above the substratum are 3 - 4 mm to one side of the larva. There is also evidence of turbulence around the thorax and head of the larva (fig. 1.23aII, III; 1.23bII).

The greater coordinate interval of velocity diagram #23b results in fewer vectors. Readings are averaged over a greater volume of flow, consequently vectors are based on a greater number of readings. This does not mean a greater reliability or accuracy of the measurement of flow compared to #23a, however, because the vectors are distributed over a greater part of the velocity gradient. Furthermore, the increase in area over which the vectors are averaged results in a loss of detail in velocity measurement. Although the velocity gradient is still demonstrated, there is little evidence of turbulence. The velocity diagram with larger coordinate intervals covers a slightly larger area and therefore includes a larger total number of readings.

Six vectors in the boundary layer of profile #23b are drawn at the substratum. In the vector analysis, these vectors were located 1 mm

below the substratum! However, since that is impossible, their negative position on the Y-axis is probably due to imprecise orientation of the prism.

1.4. DISCUSSION

1.4.1. Larval orientation

Black fly larvae need a minimum rate of flow in order for their fans to remain open against the current (Harrod 1965). Rate of water flow to which fans are exposed depends on the site of attachment selected by the larva and height of fans above the substratum. Height of fans above the substratum is dependent on two factors:

1. the degree a larva rotates itself around its longitudinal axis, and
2. the amount the larva is deflected by the flow of water.

Larvae are usually reported to rotate 180° around their longitudinal body axis (sect. 1.1.1.), however, a rotation of 180° is not always necessary in order for a larva to hold its fans facing the current. Larvae can rotate in either direction (figs. 1.17, 1.18), and rotation is an active process. A larva rotated 180° holds its fans higher above the substratum than if it were rotated less than 180° . The influence of the degree of rotation on rate of water flow to which fans are exposed is limited to the velocity gradient within 1 - 2 mm above the substratum.

With the fans extended away from the body when filtering, larvae reduce the influence of the body boundary layer on water flowing through the fans.

The amount a larva is deflected is determined by rate of water flow. The angle of deflection is a measure of drag force on the body. It is also dependent both on rate of water flow and size and shape of the larva and degree of larval rotation. Drag on the body is calculated as:

$$D = \rho \mu A C_d$$

where ' ρ ' is the density of water, ' μ ' is the rate of water flow, ' A ' is the critical area, and ' C_d ' is the drag coefficient dependent on the Reynold's Number. In this case, the critical area, ' A ', is that area of the body facing the current and is dependent on the angle of deflection. As the rate of water flow increases, the area the larva exposes to the current decreases. Thus the increase in angle of deflection counteracts the increase in drag which results from exposure to a higher rate of water flow.

In the same way, the avoidance reaction of larvae reduces drag. In bringing its body down to the substratum, a larva not only avoids faster rates of flow, but also decreases its critical area.

Over the upper range of Reynold's Numbers for black fly larvae drag developed on a body is proportional to the square of the rate of water flow. Thus when the Reynold's Number is higher than about 100, the drag a larva must withstand increases at a slower rate than the rate of water flow.

At lower Reynold's Numbers, below about 1 - 30, drag developed over a body is directly proportional to the rate of flow. Thus, at these Reynold's Numbers, occurring when larvae are small or the rate of flow is slow (about 3 cm/sec), the drag a larva must withstand increases directly with the rate of flow.

The theoretical relationship between the angle of deflection and water flow is not demonstrated in the velocity profiles. The larva of #23 (fig. 1.23) was exposed to a slower velocity than that of #22 (fig. 1.22), but was deflected a greater amount. However, the plots of angle of deflection against water flow of velocity profiles #18, #19, and #23 all fall within the distribution of plots of angle of deflection against rate of water flow (sect. 1.1.3.1, fig. 1.5).

Variation of angle of deflection of larvae exposed to similar velocities is due to variation in size and posture of larvae and error in measuring the angle of deflection. The angle of deflection is measured only in the plane of the direction of flow of the mainstream and side wall of the flume. Direction of flow and larval orientation may also be along the Z-axis.

Larvae differ in size with age, and to a lesser extent, with species. The size of a larva influences the amount the larva is deflected. Larval posture varies and larvae can hold their heads in several positions (sect. 1.3.1.). These factors probably account for differences in feeding posture between larvae of different species exposed to the same velocity, reported by Kurtak (1973).

Thus, larvae passively reduce drag on their bodies while opening their fans against faster flowing water above the boundary layer.

The passive nature of larval orientation is supported by observations of dead larvae which remain attached and deflected by the current (Grenier 1949, and pers. obs.). However, live larvae are capable of holding themselves erect against the current, and do so immediately before and after changing their sites of attachment (Grenier 1949, and pers. obs.).

The boundary layer around the larval body demonstrates the restriction of mixing of materials between the boundary layer and areas of faster flow. This phenomenon is also demonstrated by the scarcity of aluminium flakes recorded in the boundary layer over the substratum. At heights above the substratum which larvae filter, water flow is more rapid and transport is greater concentration of particles.

Mixing of materials other than aluminium flakes is similarly restricted. This is important in relation to control programmes because the amount of insecticide to which larvae are actually exposed is far less than that dispersed in water just above the larvae.

1.4.2. Flow profiles around larvae

Turbulence demonstrated in figs. 1.7.- 1.9, 1.11, 1.12, 1.14 and 1.17 is typical of flow patterns to which larvae were exposed.

Observations of Trivalleto and Décamps (1968) and Kurtak (1973) show that eddy formation downstream from objects, and flow through fans is dependent on rate of water flow. The upwards direction of turbulence downstream from larvae increases mixing of materials in this area. Filter-feeders downstream from populations of black fly larvae must benefit from this turbulence through an increase in available food supply.

This phenomenon is an important factor in the distribution of larvae over the substratum. Larvae of some species occur masses. This bunching of larvae increases the concentration of food available to larvae downstream, and compensates in part for the low level of mixing of materials in the slow flowing water along the substratum.

The distribution of blurred streaks and vectors (sect. 1.3.1.2., fig. 1.9, 1.11) around larvae is determined by the pattern of flow in the flume. The pattern of flow around an object is determined by the size of the object and velocity, viscosity, and density of the medium of flow. These factors are incorporated in the Reynold's Number. Turbulence downstream from the larva is characteristic of patterns of flow around an object with a Reynold's Number ranging from above 1 to between 2×10^5 and 2×10^6 (Alexander 1971). The flow separates as it passes an object, and flow over the upper surface of the object is smooth. Flow close to the object, is almost as fast as flow further away, thus the main gradient of velocity is in the boundary layer, in which flow is more or less laminar. Water Flow in these conditions, forms a wake of eddies downstream from the object (Alexander 1971).

Thus flow downstream from a black fly larva conforms to the pattern of flow around an object with a Reynold's Number calculated here for black fly larvae. The lack of mixing between the boundary layer and flow further away, illustrated in fig. 1.16, is characteristic of laminar flow.

Drag on a body in this type of flow pattern is partly due to the viscosity of water in the boundary layer and partly due to the changed momentum of the flowing water (Alexander 1971). The latter component of drag is greatly reduced by streamlining.

Because flow of the mainstream is not really laminar, the aluminium flakes were dispersed unevenly and the numbers of readings on which vectors are based varies. Variation in velocity at the same height above the substratum is partly due to nonlaminar flow, and is partly due to presence of the larva. In the 3-d profiles, the flow pattern is also influenced by the presence of the prism.

The boundary layer over the substratum is recognized by slow rates of flow and the scarcity of vectors. The upper limit of the boundary layer is poorly defined. Velocity increases with height above the substratum in a gradient. There is no sharp division between the boundary layer along the substratum and flow above the substratum. Vectors less than 1 mm above the substratum are 30 - 60% slower than those 1.3 - 1.9 mm above the substratum, and 50 - 70% slower than those 3.2 - 4.5 mm above the substratum. On the basis of the distribution and magnitude of vectors, the boundary layer is estimated to be less than 2.00 mm thick for the profiles considered here.

1.4.3. Velocity profiles around larvae

Rates of flow measured by the velocity profiles are slower than those recorded by the midget current meter. However, with one exception in #18, the two techniques are consistent, both recording similar rates of flow. In profile #18 (fig. 1.18), the vectors record a higher rate of flow than that of the other 2-d profiles, and the midget current meter recorded a slower rate of flow (table 1.1).

The midget current meter provides recordings of faster rates of flow than the velocity profiles for the same flume conditions because the current meter measures flow over a greater area, 1.5 cm, the diameter of the paddle. In these studies, velocity profiles determine the rate of flow over a height of 6 mm above the substratum, and do not incorporate as much of the velocity gradient. Vectors at a height of 4.5 - 5.5 mm above the substratum record velocity as much as 10 cm/sec slower than the current meter exposed to the same flume conditions. An exception occurred in the 3-d profile, #22, in which vectors record a faster velocity (table 1.1.).

The midget current meter is not sufficiently accurate to record microcurrents in the vicinity of black-fly larvae. Velocity profiles give more detailed and more accurate measurement of flow in the immediate vicinity of larvae, for example, within 3 - 4 mm of the substratum.

The velocity gradient and boundary layer are better represented in the 2-d velocity profiles than in the 3-d profiles. Areas of turbulence

are also better represented, however, the distribution of vectors, and therefore measurement of velocity, is less detailed.

The 3-d profiles provide more information on the distribution of vectors because the position of each vector is provided in two different views. However, because only the paths of flakes of aluminium travelling parallel to both the film and the vertical surface of the prism are used for 3-d analysis, fewer readings were available for the 3-d profiles. In turbulent areas, in which direction of flow was continually changing, very few vectors were recorded.

The precision of measurements provided by vectors in 3-d profiles is not necessarily lower than those of 2-d vectors, which are based on more readings, because the 2-d vectors are based on readings spread over a greater area of flow over which there is a gradient of velocity. The area over which readings were averaged and vectors calculated was selected by the computer programme, and is adjustable.

A disadvantage of the 3-d profiles in comparison with the 2-d profiles is the requirement that the two views be filmed simultaneously. Each frame of the film must include both views, and this is possible only with a smaller scale of magnification (fig. 1.15.). For this reason, 3-d profiles include a smaller area around the larva.

Turbulence is less well represented in vector profiles than in the flow diagrams. Paths of aluminium flakes in turbulent flow are only rarely represented as a series of dots suitable for computer analysis.

1.4.4. Discussion of technique

1.4.4.1. Sources of error in velocity measurement

A basic assumption of the technique is that the movement of aluminium flakes is the same as that of the water. However, the presence of one flake of aluminium influences the movement of another. Collisions between flakes tend to retard their movement through the water, and the more concentrated the aluminium suspension is, the greater these influences become. In addition, the aluminium flakes tend to settle out of suspension. Errors due to these factors are negligible when considered in relation to the intrinsic variation of the flow under study.

The reference grid on which the larva attached itself is essential for identifying the two paths of each aluminium flake in the 3-d views. If the prism is not oriented correctly, the prism image is skewed, and this identification becomes difficult. The profile of a skewed prism image does not represent a true lateral view of the actual image, and 3-d velocity measurements are then biased. Because of the shape of the accessory lens there is some distortion at the margins of the prism image on the cinefilm.

The accuracy of velocity measurements of the cinefilm is also influenced by the orientation of the camera, the accessory lens and the plexiglass disc. If the cinefilm, lens, and disc are not parallel to the bottom of the flume, there will be distortion in magnification. Because of the optical properties of water, flakes filmed through different depths of water will be differentially magnified.

However, the distance between the film and the larva is sufficiently great that the paths of light between them are parallel, and the effect of differential magnification and of any variations in thickness of plexiglass are negligible.

The depth of focus also influences the accuracy of measurement, particularly in the 2-d system in which the larva was close to the side wall of the flume. Velocity of water increases with increasing distance away from the wall of the flume, so that water passing behind the larvae moves faster than water passing between the larva and the flume wall. The depth of field in the 2-d profiles is approximately one centimeter, so the vectors are averages of paths of aluminium flakes flowing in that volume of water described by selected coordinates and a depth of one centimeter.

1.4.4.2.3 Advantages and disadvantages of the technique

Numerous measurements can be made rapidly and accurately with a digitizer. The same point can be measured to within 37.10 mv, or 0.209 cm for the X axis, and 0.218 cm for the Y axis. After correcting for the magnification factor, these readings gave a variation of 0.040 mm - 0.060 mm for each point on the 2-d films, and 0.075 mm - 0.190 mm for each point on the 3-d films. Because of this variation, higher magnifications and longer paths of aluminium flakes (slower film speed) allow a greater accuracy in measurement. Velocity readings from the 3-d films, especially those of the prism view, are therefore not as accurate as those from the 2-d films, and the 12 fps film gives greater accuracy than the 24 fps film.

Larvae are sensitive to experimental design. They are sensitive to mechanical disturbances in the room as well as in the flume, and they are disturbed by the stroboscope. If the aluminium suspension was too concentrated, larvae frequently changed their site of attachment, requiring a rearrangement of the equipment.

The technique is limited to the laboratory. Flow patterns studied are greatly influenced by laboratory conditions, including the dimensions of the flume, the presence of the prism and form, and the site of attachment of the larva in the flume. In addition, the results are not immediate; the film has to be developed and then analysed.

The main advantage of the technique lies in its accuracy which is far greater than that of other types of measuring techniques. The technique is flexible. Conditions of flow can be determined to a large extent by laboratory conditions and flume controls.

1.5. CONCLUSION

In lotic environments the boundary layer is a benefit to benthic organisms because the force to which these organisms are exposed is reduced in the slower rates of flow. However, the boundary layer is a potential problem because the reduction of rates of flow also reduces transportation and mixing of materials vital for survival. For black fly larvae and other animals depending on movement of water for food supply and on diffusion for exchange of gases, the boundary layer is potentially lethal.

Most of the body of black fly larvae when they are filtering, and all of the body when they are exhibiting the avoidance reaction, is contained within the boundary layer; and larvae benefit from the reduction in force to which they are exposed. This reduction, in conjunction with the energy-economic mechanism of attachment, enables black fly larvae to survive in fast flowing waters which are too severe for some of the other benthic animals.

Black fly larvae require adequate water flow for their passive filtering mode of feeding. In selecting areas of substratum where flow is rapid, larvae choose areas where the boundary layer is thinnest. Thus larvae avoid potential problems of insufficient rate of exchange of materials, and ensure that their fans are exposed to water flow fast enough to provide an adequate food supply. In areas where the boundary layer is thin, flow is fast and tends to be smooth, facilitating the filtering activity of the fans.

The control of the angle of deflection of larvae by the current is an automatic adjustment to the rate of water flow. Through this passive body reflex, the critical area of the larva and hence drag on the body is regulated. Both drag on a larva and the angle of deflection increase with increasing rates of flow. However, with increasing angle of deflection, drag on the larva is reduced because the critical area is reduced and the streamlining of the body is increased. The height above the substratum at which the larvae hold their fans is primarily determined by the angle of deflection. Rate of water flow influences streamlining, and hence drag on the larva, as well as the level at which water is filtered.

The influence of angle of deflection over rate of water flow filtered by larvae is limited. Larval selection of site of attachment has a greater influence on rate of flow of this water.

One consequence of passive feeding behaviour is the unselected nature of larval food. Larvae select food only on the basis of size (Chance 1970a). Thus they ingest much indigestible material which they must pass through their guts. However, recent observations of larvae feeding on colloids (Wotton 1976), organic material attached to the surface of inorganic particles (Cummins, pers. comm.) and earlier observations of larvae feeding on bacteria (Predeen 1960, 1964) indicate that much of the apparently useless ingested material may in fact supply larvae with food.

A second consequence of passive filter-feeding is the low level of filtering efficiency. Larvae trap only a small amount of available

material (Kurtak 1973, and sect. 2.4.4.). However, the low level of efficiency is compensated for by a low expenditure of energy during feeding.

The photographic technique of measuring velocity profiles provides more accurate measurements of rates of water flow than commonly used flowmeters, and in addition, provides information on direction of flow and distribution of turbulence. It also provides a permanent record of velocity profiles. The technique can provide valuable information on feeding behaviour of the larvae, measurements of flow of water filtered by the larvae, and the pattern of dispersal of particles, as for example, of food or larvicides, in the vicinity of the larvae.

2.0. FEEDING BEHAVIOUR OF BLACK FLIES LARVAE

2.1. LITERATURE REVIEW

Jørgensen (1966, 1975) comprehensively reviewed filter-feeding among invertebrates, with emphasis on marine animals. Filter-feeding by stream insects was reviewed recently by Hynes (1970a, b) and Chance (1969, 1970a). Grenier (1949) reviewed in detail early works on larval simuliid feeding and made significant contributions to the knowledge of the biology of larval black flies. The most important early works of filter-feeding among larval black flies are those of Naumann (1924), Puri (1925), Wu (1931), and Fortner (1937). Important works on the biology of larval black flies and those especially concerned with feeding behaviour are Peterson (1956), Fredeen (1959, 1964), Carlsson (1962, 1967), Maitland and Penny (1967), and Glötzel (1973).

Ladle (1972) and Ladle et al. (1972) studied filter-feeding in relation to productivity of black fly larvae. Neveu (1972, 1973a, b, c) has recently completed a long term study on the biology of several species of black flies in mountain streams. Kurtak (1973) studied in detail the structure of the cephalic fans and larval feeding behaviour of several species of black flies. He was primarily concerned with the influence of current and type and concentration of particles on feeding efficiency of the larvae. Elouard and Elsen (1975) studied the rate of ingestion of larval *Simulium damnosum*. They showed that rate of ingestion varies with instar and was dependent on velocity and concentration of particles.

Chance (1970a), Couvert (1970), Craig (1974) and Davies (1974) studied the structure and function of the cephalic fans and mouthparts of larval black flies. Black fly larvae are passive filter-feeders, i.e. they rely on the current to transport their food to them. Larvae filter particulate matter from the water using specialized feeding appendages called cephalic fans. Typical of passive filterers, larvae are unselective with respect to quality of food, and ingest anything of suitable size (Chance 1970a). Recently, Wotton (1976) showed that larvae ingest particles of colloidal size.

The frequency size distribution of ingested material differs between species studied, but these differences are not related to anatomical differences of the feeding apparatus (Chance 1970a). Morphological differences between cephalic fans of some species are related to the current regime of the habitat (Grenier 1949, Lewis 1953, Kurtak 1973) and the nature and abundance of particulate matter (Carlsson 1962).

Filter-feeding by black fly larvae is quite automatic. Larvae continue to feed in the absence of particulate matter, for example, in distilled water (Davies and Syme 1958, Mahsingh et al 1972) and filtered water (Wu 1931, Fortner 1937). They are considered to be continuous feeders (Ladle et al 1972). Larvae of several species, including *Simulium vittatum*, feed at all times of the day (Kureck 1969, Elouard and Elsen 1975, Mulla and Lacey 1976), and there is no circadian rhythm of feeding (Ladle et al 1972, Mulla and Lacey 1976). However, Elouard and Elsen (1975) found that larvae of *S. damnosum* ingested at a faster

rate at night than during the day. Other workers also determined an increase in activity of larvae in darkness (Chaston 1968, Elliott 1967, 1969, 1971) and this is reflected in an increase in their numbers in the organic drift at night (Elliott 1967, 1969). Adult black flies also exhibit periodic behaviours (Wolfe and Peterson 1960, Corbet 1967, Kureck 1969, Raastad and Mehl 1973).

Velocity affects the function of the cephalic fans (Wu 1931, Fortner 1937, Harrod 1965, Kurtak 1973) as well as feeding, by influencing the availability of food (Fredeen 1964, Glötzel 1973, Neveu 1973a, Elouard and Elsen 1975, Mulla and Lacey 1976).

Concentration of particles and differences in types of particles also influence the rate of ingestion by larvae (Fredeen 1964, Glötzel 1973, Kurtak 1973, Elouard and Elsen 1975).

The influence of temperature on feeding of various species has been studied by Ladle et al (1972), Mansingh et al (1972), Webster (1973), Kurtak (1973), Becker (1973), and Mulla and Lacey (1976). They showed that ingestion tends to increase with increasing temperature. Webster determined a maximum rate of feeding at 20°C for *Simulium vittatum* larvae. Larvae feed at temperatures of 5°C - 25°C (Webster 1973) and survive temperatures as high as 33°C (Fredeen 1959). Ladle (1972) found a minimum rate of feeding at 5°C - 8°C for larvae of *Simulium equinum* and *Simulium ornatum*. However, between 8°C - 21°C, temperature had no effect on feeding rate. Mansingh et al (1972) showed that larvae of *Prosimulium* spp. feed very little or not at all at freezing temperatures (1°C - 4°C), and that assimilation of food was greatly

reduced at low temperatures (4C) but increased with increasing temperatures up to 9C.

Rate of development of larvae is correlated with temperature (Sommerman et al 1955; Smith 1969; Neveu 1973a, b; Mokry 1976). Longer development periods result in larger individual larvae and adults. The larger adults are provided with larger fat bodies and in some species are autogenous for the first ovarian cycles (Rubtzov 1965, Neveu 1973a). Mokry (1976) observed a wide range of rates of growth of individual larvae of a laboratory population of *Simulium venustum*.

Observations on overwintering populations of larvae of several species show that larvae continue to grow during the winter (Davies 1961, Lewis and Bennett 1975, Thorup 1974), however, growth may be retarded (Davies and Syme 1958, Peterson 1960). Mansingh and Steele (1973) studied overwintering, or dormancy ('oligopause'), among larvae of *Prosimulium mysticum*. Temperature-regulated dormancy occurs at temperatures below 4C and is terminated rapidly when temperatures rise above 4C. Dormant larvae have a greatly reduced rate of growth.

Davies and Syme (1958) determined that the rate of growth of larvae of *Prosimulium mixtum* and *Prosimulium fuscum* differed, but that there was no relation between rate of growth and temperature, water flow, or amount of suspended material in the water. Fredeen (1964) showed that rate of growth was dependent on level of feeding, which was not dependent on age of larva, but was dependent on population densities and amount of food available. Ladle et al (1972) reported

that feeding activity varied with species and site but that there was no measurable differences of rate of feeding between species or size of larva. However, other workers have demonstrated differences in rate of feeding with age of larva. Elouard and Elsen (1975) demonstrated a direct relationship between rate of feeding and age of *S. damnosum* larvae, and Mulla and Lacey (1976) show an inverse relationship between rate of feeding and age of larvae of three species. They also found differences in rates of ingestion between species. Kurtak (1973) stated that the rate of feeding varies within seasonal period.

Sommerman et al (1955) reported that rate of development is slower among crowded populations. Anderson and Dicke (1960) suggested that crowding reduced size and survival of larvae. Barber and Kevern (1973) determined a higher productivity of black flies exposed to low or moderate food supplies than black flies exposed to higher food supplies.

A number of workers have measured the amount of material ingested by larvae, either by measuring the rate of gut filling (gut retention time) or by determining the dry weight of material ingested. Recorded times larvae take to fill their guts vary from 20 - 30 minutes (Naumann 1924, Fredeen 1964, Ladle et al 1972, Elouard and Elsen 1975, Mulla and Lacey 1976), 40 - 60 minutes (Kurtak 1973), 90 minutes (Peterson 1956, Elouard and Elsen 1975) and 24 - 25 hours (Davies and Syme 1958). When exposed to large particles, larvae can fill their guts within 10 minutes (Chance 1969).

Weight of ingested material has been measured by Peterson (1956), Fredeen (1964), Schwoerbel (1971), Ladle et al (1972), Kurtak (1973), and Neveu (1973c). Rate of gut filling or amount of ingested material reflects the size and availability of particles as well as feeding efficiency¹. Feeding efficiency varies with species, feeding conditions, and age of larva. It varies from 0.001 - 10%, although efficiencies of 0.01 - 5% are more common (Kurtak 1973).

2.2. MATERIALS AND METHODS

2.2.1. Experimental design

Fifteen feeding experiments were carried out on larvae of *Simulium vittatum* Zett. Larvae were collected locally (Sturgeon River, nr. St. Albert, Alberta) and maintained in battery jars (Chance 1970a) with an ample supply of food. The day prior to each feeding experiment, larvae were added to the flume (sect. 1.2.1.) and fed yeast. Before each experiment, temperature, pH, turbidity, and volume of water were recorded. Temperature and pH were maintained within a narrow range: 9.5C - 10.0C (Palmer temperature recorder, Palmer Instruments, Cincinnati, Ohio), pH of 7.0 - 7.5 (Hach kit, model AL-36-P, Hach Chemical Corporation, Ames, Iowa). Turbidity was always less than 25 ppm, the minimum value measurable using the Jackson Turbidimeter, a standard

¹ Feeding efficiency (Kurtak 1973):

$$\frac{\text{No. of particles ingested}}{\text{No. of particles offered}} \times 100$$

turbidimeter. The volume of water in the flume ranged from 87 - 125 litres. The depth of the water in the test section varied, according to rate of flow and ranged from 9 cm for slow rates of flow to 7 cm for fast rates of flow. The water was always saturated with oxygen.

Feeding experiments were carried out for three time periods: 30, 60, and 90 minutes. Immediately before each experiment, velocity of the water was recorded (sect. 2.2.2.). At the start of each experiment a known weight of a synthetic particle (sect. 2.2.3.) was added to the water in the reservoir. In 11 of the experiments, a second colour of synthetic particle was added 30 or 60 minutes after the first; these experiments are referred to as 'doubled' experiments (sect. 2.3.1., table 2.1.). At the end of each experiment, the pump of the flume was switched off, whereupon the larvae immediately stopped feeding. All larvae except those within 3 cm of each side wall and 15 cm of the entrance and exit of the flume were collected and frozen until they could be examined. Larvae close to the walls and entrance and exit of flume were not collected as water flow in these areas was not the same as that in the centre of the flume.

To avoid any possibility of circadian rhythm or fluctuations in activity influencing feeding behaviour, experiments were always done in the early afternoon.

For the duration of each experiment, the charcoal filter was removed from the reservoir of the flume and to reduce turbulence in the

flume, a second, saran mesh, filter was inserted as a baffle, at the level of the sluice gate. The sluice gate and saran mesh filter were both 1 cm above the substratum. The tail gate was adjusted flush with the bottom of the flume.

Approximately 500 larvae from each experiment were examined. For analysis, larvae were grouped into three stages of development: small, medium and large size (Chance 1970a). The population of *Simulium vittatum* studied was an overwintering population and was parasitized by the nematode, *Gastromernis viridis* Welch, and by microsporidians (sect. 2.3.2.). Because of the effect of the parasite on its host (Strickland 1911, 1913; Rubstov 1966) parasitized larvae are treated separately from healthy larvae. The number of medium parasitized larvae in each experiment is too small for reliable analysis and only large parasitized larvae ("Large P.") are considered.

As a measure of ingestion¹, I used the percent of total gut length filled during the experimental period. This percentage is based on the position in the gut of the first synthetic particle ingested, i.e. the particle closest to the anus. The length of the gut is taken as the distance between the hypopharyngeal suspensorium and the anus. The alimentary canal and its contents were examined after the larvae were thawed, dehydrated in 95% ethanol for about 20 minutes and then cleared in benzene.

¹ Ingestion: Taking in of material into the alimentary canal.

Basing the amount of particles ingested during the experimental period on the position of the first particle ingested requires the assumption that passage of material through the gut is directly dependent on rate of ingestion of subsequently filtered material. Other works show that this assumption is valid for larvae of *Prosimulium fuscum* and *Prosimulium mixtum* (Davies and Syme 1958), *Prosimulium mysticum* Mansingh et al (1972), *Simulium ornatum* (Glötzel 1973), *Simulium damnosum* (Elouard and Elsen 1975), *Simulium vittatum*, *Simulium tescorum* and *Simulium argus* (Mulla and Lacey 1976), and *Culex pipiens* (Dadd 1968; 1970a, b; 1971). Larvae of *Prosimulium* exposed to distilled water at 9C took two weeks (Davies and Syme 1958) or longer (Mansingh et al 1972) to empty their guts. Similarly, *Simulium damnosum* larvae (Elouard and Elsen 1975) and *Culex pipiens* larvae (Dadd 1968; 1970a, b; 1971) immersed in distilled water made typical filtering motions, but their gut contents did not move.

A second assumption is that the particle ingested first remains the one closest to the anus, that is, there is very little if any mixing of particles along the length of the gut. During the laboratory experiments, I exposed larvae suddenly to high concentrations of new and different particles, and the border in the gut between new particles and particles ingested previously was always distinct, indicating no mixing. Ladle et al (1972) found the same situation among larvae of *S. ornatum* which he exposed to charcoal particles in the field.

2.2.2. Measurement of water velocity

To measure the velocity of water, I used a flowmeter that was an anemometer (DISA Type 55D05 battery-operated, Canaden Products Limited, Montreal) equipped with a hot film probe (model 1210-60W, Thermal-Systems Inc., Saint Paul, Minn.) designed for use in water. This system is temperature sensitive and not linearized. I therefore calibrated the flowmeter at flume temperatures against known velocities, using a specially built container set on top of a kymograph drum to give accurately known velocities (fig. 2.1). This container was made out of 15 cm long sections of 4 cm thick Plexiglas tubing with inner diameters of 18 cm and 27 cm. These were glued to a plexiglass disc 30 cm in diameter with the smaller section inside the larger one to make a circular trough. When the kymograph drum was rotated, water in the outer compartment moved at a known velocity relative to the probe, which was kept stationary. Gauze baffles along the walls of the outer compartment kept the water motionless relative to the walls of the container, as demonstrated by the use of india ink. The inner compartment was filled with mixtures of ice, salt, and hot or cold water to maintain the water in the outer compartment at flume water temperatures, 9.0 - 10.0C. The probe was calibrated by immersing it in water in the outer compartment, immediately upstream from a thermometer, and rotating the kymograph drum. The velocity of water in which the probe was immersed was calculated from the speed of the kymograph and the circumference of a circle with its radius, the distance between the probe and the centre of the container.

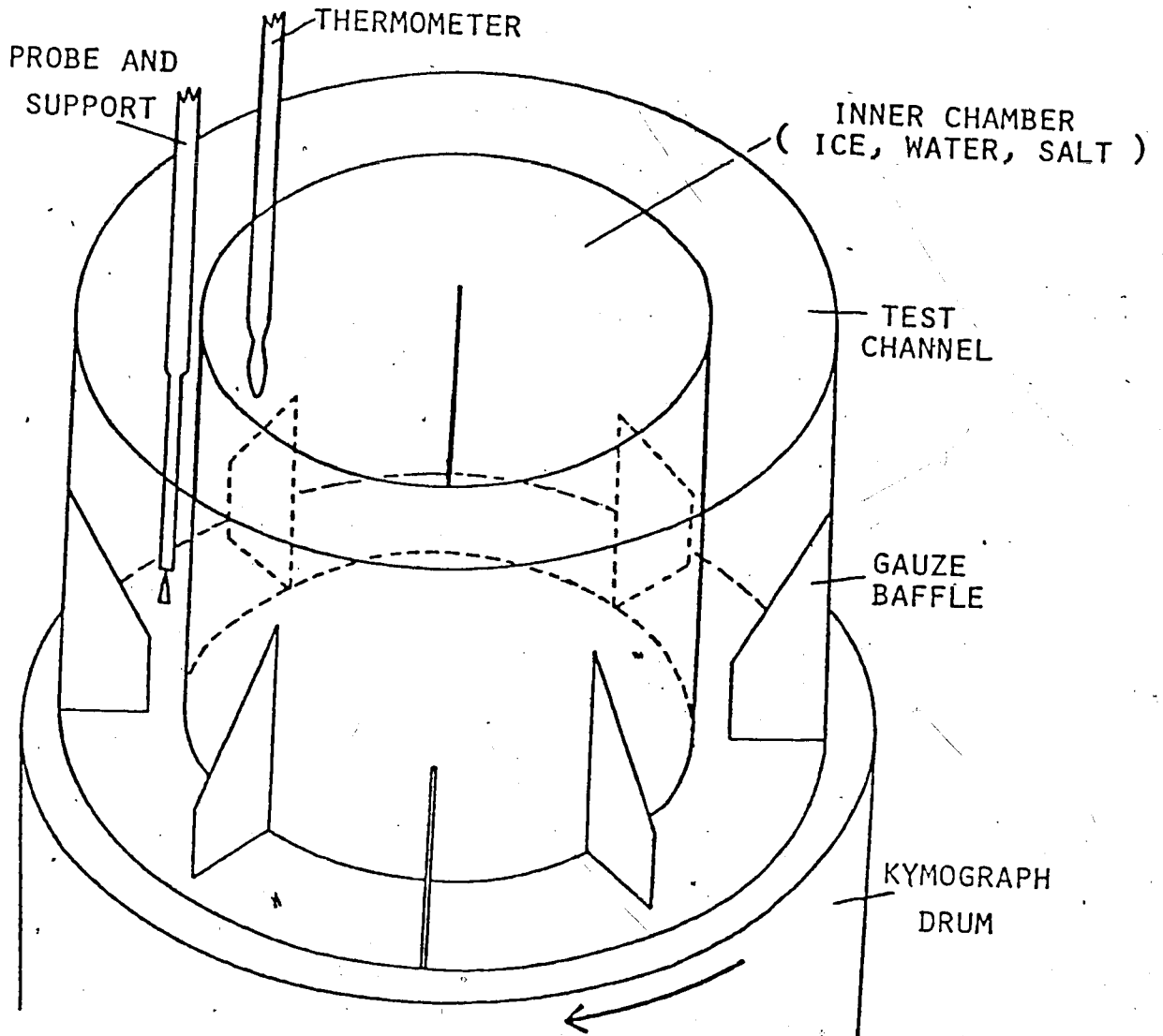

FIG. 2.1. CALIBRATION VESSEL FOR HOT FILM PROBE

Flowmeter readings at any particular site varied according to the orientation of the probe tip with respect to direction of water flow. Thus the flowmeter provided directional information as well as rates of flow. Because water flow in the flume was smooth and regular, readings were taken in the direction of the mainstream.

The probe tip of the flowmeter is 3.5 x 0.5 mm, small enough to measure flow in the boundary layer, and even record turbulence immediately downstream from the larvae (sect. 1.3.1.2.). Using this system, I was able to measure flow in the vicinity of the larval heads; water which the larvae were actually filtering. The velocity reading for each experiment is the mean of 15 readings taken over the surface of the flume at the level of the larval heads, which varied from 1.5 - 4.0 mm above the substratum, depending on the water velocity (sect. 2.3.1.).

2.2.3. Measurement of concentration of particles

To determine the influence of concentration of particulate food on the filtering behaviour of the larvae, I added differing amounts of a synthetic particle: red particles (20 - 30 μm in diameter) and green particles (30 - 40 μm in diameter), 'Micronic Beads' (Ionics Incorporated, Mass.). Because black fly larvae select food on the basis of size, these plastic particles are an acceptable substitute for food (Chance 1969, 1970a). Since the particles are brightly coloured, uniform in shape and size, have a specific gravity of 1.0, and are chemically inert, using them rather than an irregularly shaped

particle greatly facilitates study of the filtering behaviour of the larvae. Differences in sizes of the particles is too small to influence ingestion by larvae, with the possible exception of ingestion by small larvae (Chance 1970a).

To determine the concentrations of particles to which larvae were exposed, water samples of 250 - 300 ml were collected at 10 - 15 minute intervals at the exit of the flume. These samples were then filtered using Metricel® filters after which the particles were counted and the number of particles per ml calculated.

2.3. RESULTS

2.3.1. Experimental conditions

The range of velocities to which larvae were exposed was limited by larval behaviour and flume capacity. The slowest velocity, 3.70 ± 0.90 cm/sec, was the slowest flow in which larvae continued normal filtering movements. The maximum velocity to which larvae were exposed was 34.75 ± 2.75 cm/sec, the fastest flow in which larvae continued normal filtering movements. At faster velocities air bubbles produced by cavitation in the pump adhered to the larval fans and mouthparts and appeared to hinder normal filtering movements.

Four different weights of particles of both colours were added to the water in the flume: 0.05 g, 0.1 g, 0.2 g, 0.4 g. Since the green particles are larger than the red ones, fewer of them were added per

unit weight of particles. The concentration of particles in the water decreased with time (fig. 2.2.). This decrease is due in part to the particles becoming caught in the sticky secretion produced by the larvae while they attach themselves to the substratum. Particles may also have been caught in the pump and on the inner surfaces of the flume. Ingestion of particles by the larvae may also have contributed to the decrease.

To estimate the average concentration of particles to which the larvae were exposed for the duration of the feeding periods, I analysed the concentration of particles using a model I regression (Sokal and Rohlf 1969) against time. A mean concentration of particles, $[p]$, is based on the mid-range value ($X_{max}/2$) and the slope of the regression line (Appendix B). In experiments in which a second colour of particles was added after 30 or 60 minutes, two regressions were carried out, one for the time when only one colour of particle was present and a second when both colours were present (Appendix B). The two \bar{Y} values were determined for each regression line and multiplied by the maximum time (in minutes) of each regression line. The two products were then added and the sum divided by the total time (in minutes) of the feeding period. Logarithmic transformation of particle concentration was applied if it improved the linear regression line. The average $[p]$ to which larvae were exposed ranged from less than 4 particles/ml to 158 particles/ml.

The rate of reduction of concentration of particles was not the same in all experiments. Slopes of regressions of $[p]$ against time

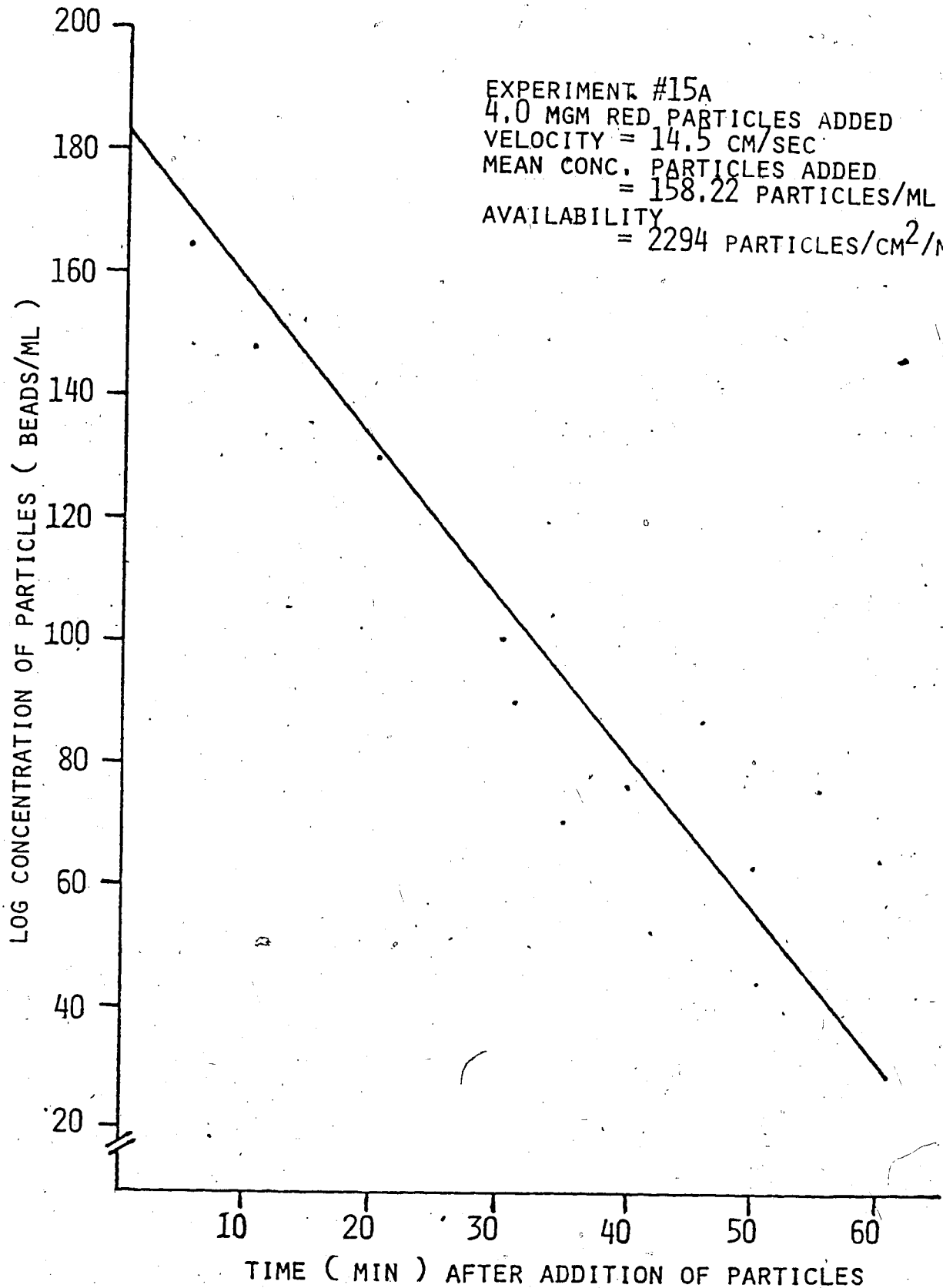

FIG. 2.2. REGRESSION OF LOG CONCENTRATION OF PARTICLES WITH TIME, AS AN EXAMPLE OF REDUCTION OF PARTICLE CONCENTRATION WITH TIME (EXPERIMENT #15A).

vary (Appendix C). Differences in slopes occur because factors which determine the slope of the line vary with experiment. These factors include: 1) velocity, and therefore the carrying capacity of the water and mixing of particles after their addition to the flume; 2) differing amounts of particles added to the water; 3) non-laminar flow in the flume, and possible non-uniform distribution of particles in the water which contributed to sampling error; 4) varied duration of feeding periods; 5) differing numbers of larvae and therefore production of sticky secretion among experiments; and 6) possible differences in ingestion by larvae. There is no apparent relationship between either slopes of regression lines or significance of regression and the following 5 factors: amount of particles added to the flume, numbers of larvae in the flume, availability of particles, average ingestion by larvae, and proportion of larvae which fed during the experiment. A larger proportion of the slopes of regression lines are significant ($P = 0.1$ or less) in the longer experiments (Appendix C).

For each experiment I calculated an index of availability of particles to estimate the numbers of particles to which larvae were exposed. This index is the product of mean $[p]$ multiplied by velocity for each experiment, and is rounded off to the nearest integer, e.g. experiment #6, $23.77 \text{ particles/ml} \times 7.29 \text{ cm/sec} = 173.28 = 173 \text{ particles/cm}^2/\text{sec}$.

Experiments are grouped according to their duration, and these groups are considered separately. Because of the reduction of $[p]$ with

time, the availability of particles decreases with time. A 90-minute experiment with a mean [p] of 5, for example, may have had [p] 's of 10, 3 and 2 particles/ml during three 30 minute periods. Thus the availability of particles over 90 minutes is less than 3 times the availability over 30 minutes.

Because of the automatic nature of feeding behaviour of larvae and because [p] available varies with time, each part of the 'doubled' experiments is treated separately, as single experiments. The duration and mean [p] differs between each part of the doubled experiments, but velocity does not.

Numbers of larvae in each class and total numbers of larvae in the flume for each experiment are tabulated in Appendix D. With the possible exception of experiments 1a and 1b, numbers of larvae in the flume do not appear to influence ingestion by larvae or the proportion of larvae which fed. The proportions of each larval class in the total flume population varied with each experiment, and the size of larval class and numbers of larvae in the flume reflect changes in the population of larvae maintained in battery jars and in the field.

Water velocity, mean [p] to which the larvae were exposed and numbers of larvae in the flume are shown in table 2.1. Experiments are listed according to availability of particles and are numbered according to the sequence in which they were done. The 'doubled' experiments are labelled 'a' for the longer feeding period, and 'b' for the shorter one. Because of influence of water velocity on distribution of particles in the flume, higher mean [p]'s occurred only in fast velocities.

Larvae which did not have any particles in their guts are considered not to have fed during the experiment. In some cases the proportion of larvae which did not feed is high (table 2.2.). For this reason, these 'unfed' larvae are treated separately from those that fed (sect. 2.3.3.2.).

Although particles of the size of Micronic beads are readily ingested by large larvae of *S. vittatum*, small larvae ingest particles with a mean diameter of 25 μm approximately eight times as readily as particles with a mean diameter of 45 μm , and medium larvae ingest particles with a mean diameter of 25 μm approximately twice as readily as particles with a mean diameter of 45 μm (Chance 1970a).

To determine if the difference in size between red and green particles (diameters of 20 - 30 μm and 30 - 40 μm , respectively), accounted for differences in the percentage gut filled between experiments, the availability of particles was adjusted by dividing the mean concentration of green beads by 8 for small larvae, and by 2 for medium larvae (table 2.3.). This correction reduced the

Table 2.1. Velocity, concentration and availability of particles to which larvae of *Simulium vittatum* were exposed, and numbers of larvae in the flume.

Experiment No.	Time	Velocity (cm/sec)±SD	[P] ¹ (particle/ml)	Availability	No. ² larvae in flume	
10b	30 min	5.0±0.9	3.63	18	770	
5b		8.5±1.8	5.79	49	980	
7		9.7±0.8	11.89	115	530	
6		7.3±1.1	23.77	174	370	
14b		3.7±0.9	44.63	165	1600	
2		19.4±0.2	13.73	266	450	
1b		15.3±0.8	26.34	403	2960	
3		19.0±4.3	35.15	668	520	
8b		14.3±1.0	59.08	845	680	
4b		34.8±2.8	36.50	1270	520	
15b	14.5±1.7	156.43	2268	1500		
9b	26.8±2.5	114.74	3075	510		
12b	60 min	5.5±1.2	4.00	22	620	
14a		3.7±0.9	23.34	86	1600	
11b		17.2±1.0	8.80	151	700	
13b		28.4±1.1	19.85	564	830	
8a		14.3±1.0	53.10	759	680	
9a		26.8±2.5	75.16	2014	510	
15a		14.5±1.7	158.22	2294	1500	
10a		90 min	5.0±0.9	6.88	34	770
12a			5.5±1.2	7.02	39	620
5a			8.5±1.8	10.02	85	980
11a	17.2±1.0		10.69	184	700	
1a	15.3±0.8		12.83	196	2960	
13a	28.4±1.1		19.88	565	830	
4a	34.8±2.8		31.25	1087	520	

¹ Weight of particles added are listed in Appendix B.

² Rounded off to the nearest 10.

Table 2.2. Percentage of unfed larvae of *Simulium vittatum* in each class.

Expt.	Small		Medium		Large		Large parasitized	
	n ¹	%	n	%	n	%	n	%
30 min								
1b	322	81.99	410	48.53	63	31.74	229	7.42
2	98	62.24	254	42.13	43	18.60	52	15.38
3	110	64.54	342	23.39	19	21.05	29	10.34
4b	66	71.21	327	77.37	47	30.18	53	26.41
5b	97	50.51	378	17.94	37	8.82	45	6.67
6	12	-	250	16.80	37	40.54	58	13.79
7	43	92.86	344	19.19	44	20.50	38	26.08
8b	38	50.00	394	17.30	84	13.09	43	11.63
9b	5	-	369	21.35	81	18.51	37	13.51
10b	12	-	442	28.05	66	25.75	16	-
14b	76	23.68	344	5.08	84	5.99	23	4.35
15b	69	61.32	290	12.41	95	9.47	57	7.02
60 min								
8a	40	55.00	394	9.90	84	13.51	44	11.36
9a	5	-	363	21.25	80	16.25	37	12.82
11b	12	-	439	36.73	85	14.12	20	21.05
12b	19	-	417	31.49	83	19.28	11	-
13b	114	62.28	303	29.37	65	33.84	37	10.81
14a	76	65.79	344	13.91	84	4.76	23	4.35
15a	69	33.33	290	6.90	96	6.25	57	3.51
90 min								
1a	322	61.80	410	31.71	63	46.03	229	13.97
4a	66	71.21	327	33.33	47	19.15	53	16.98
5a	99	49.49	378	12.69	37	10.81	45	8.89
10a	12	-	442	19.23	66	21.21	16	-
11a	12	-	438	12.33	83	4.82	20	5.00
12a	19	-	415	13.97	84	15.48	11	-
13a	114	36.84	301	16.95	65	12.31	37	5.40

¹ n is the total number of larvae in each class.

effective availability of particles to these larvae in most of the 30 minute experiments and all of the longer ones. However, although small and medium larvae are less efficient in ingesting the larger particles, interpretation of feeding behaviour is not affected since the order of the experiments based on availability of particles is little changed (table 2.3.).

2.3.2. Parasitism

Over 8,000 larvae were studied, 11% of which were parasitized (Appendix E). Most of the parasitized larvae were infected with the nematode, *Gastromermis viridis* Welch which occurred in 91% of large parasitized larvae and 83% of medium parasitized larvae. Three parasitic stages of the nematode were recognized: i) small, transparent juveniles; ii) large, white opaque juveniles; and iii) large green juveniles.

Protozoan parasites were recognized as white masses in the fat body of host larvae, and accounted for the remainder of the parasites.

None of the small larvae appeared to be parasitized. Infective stages of the parasites are presumably too large to be ingested by small larvae, or are too small to be detected (sect. 2.4.1.). About 3% (157 larvae) of medium larvae, and nearly half (745 larvae) of the large larvae were parasitized. Multiple parasitism occurred in both medium and large larvae (Appendix E).

Table 2.3. Availability of particles¹, after adjustment for size of particle, to larvae of *Simulium vittatum*

Expt ²	Time (min)	Larval Class ²			
		Small	Medium	Large, Large P.	
10b	30	2	9	18	
5b		6	25	49	
7		14	57	115	
6		174	174	174	
14b		165	165	165	
2		32	33	266	
1b		403	403	403	
3		668	668	668	
8b		105	422	845	
4b		159	635	1270	
15b		281	409	2268	
9b		3075	3075	3075	
12b		60	3	11	22
14a			83	84	86
11b			19	76	151
13b	70		282	564	
8a	390		548	759	
9a	1606		1775	2014	
15a	1302		1727	2294	
10a	90	29	31	34	
12a		26	31	39	
5a		71	77	85	
11a		95	133	184	
1a		145	165	196	
13a		236	377	565	
4a		717	875	1087	

¹ Particle diameters: 20 - 30 μ ; 30 - 40 μ .

² Listed within time according to availability of particles (p. 92)

2.3.3. Feeding analysis

2.3.3.1. Feeding distributions

The frequency distributions of percent gut filled within the duration of the experiment are shown in Appendix F. Several factors contribute to lack of normality in the shape of these frequency distributions. Although *Simulium vittatum* is a distinct species, it does have a high degree of chromosomal inversion (Pasternak 1964) and variability (Downes 1973). Feeding may differ between sex of individual, and the sex ratio may have differed from 1:1 among the experiments. Feeding differences during intrastadial development, especially in an overwintering population when the rate of development is very slow, may also be a factor. However, I have observed larvae filtering immediately after shedding their exuvia. Kurtak (1973) states that feeding varies within larval instar. The sometimes very high proportion of larvae which do not feed at any one time may also contribute to the heterogeneity of the frequency distribution of percent gut filled.

Larvae were grouped according to whether or not they had recently moulted or were about to moult; large larvae were also grouped according to the state of development of their pupal histoblasts. Frequency distributions of these factors follow closely frequency distribution of percentage gut filled and do not explain any of the deviations from normality in the distribution of percentage gut filled.

2.3.3.2. Feeding results

Mean percentage gut filled for larvae which fed in each class

is presented in table 2.4. In some experiments the mean is underestimated because some larvae filled their guts completely and may have defaecated particles. Analysis of ingestion by larvae which fed was carried out using 'Model 2 analysis of variance' (Sokal and Rohlf 1969) and Duncan's New Multiple Range Test (Steel and Torrie 1960). Arcsine transformation of the percentage gut filled was applied (Sokal and Rohlf 1969). Lack of feeding among larvae during the experiments was analysed using tests of independence (Sokal and Rohlf 1969). Experiments are considered separately according to duration of feeding period and the results, as follows:

- i) Ingestion among larval classes within experiments
(figs. 2.3a - c).
- ii) Ingestion within larval class among experiments:-
 - Large larvae (figs. 2.3d - f)
 - Medium larvae (figs. 2.3g - i)
 - Small larvae (figs. 2.3j - l)
 - Large parasitized larvae (figs. 2.3m - o)
- iii) Comparison of ingestion after grouping the experiments:-
 - Grouping according to velocities:
 - among larval class between velocities
 - between larval class within velocities
 - Grouping according to [p] :
 - among larval classes between [p] 's
 - between larval classes within [p] 's
- iv) Ingestion within 'doubled' experiments.
- v) Comparison of mean percentage gut filled between larval classes (using Duncan's New Multiple Range Test).
- vi) Proportion of larvae which did not feed.

Table 2.4. Mean percentage gut filled¹ in larvae of 4 classes of *Simulium vittatum*

Expt ² no.	Time (min)	Larval class											
		Small			Medium			Large			Large p. ³		
		n	\bar{x}	n	\bar{x}	n	\bar{x}	n	\bar{x}	n	\bar{x}	n	\bar{x}
10b	30	48	52.7±19.60	318	53.7±23.48 [†]	49	65.8±24.73 [†]	42	62.38±23.27				
5b			-	311	54.68±18.42	34	55.29±20.07	28	58.44±19.77				
7			-	278	62.30±18.64	35	57.86±19.65	50	41.80±16.34				
6			-	208	52.55±16.83 [†]	22	50.45±17.65	22	54.09±15.09				
14b		58	56.2±18.17	327	50.32±16.70	79	49.73±16.32	44	51.66±17.99				
2		37	56.35±18.58	147	50.37±20.48	35	65.00±17.15	212	30.99±16.62				
1b		58	53.54±21.03	211	46.57±21.48	43	26.62±15.51	26	43.85±21.78				
3		39	50.64±19.84	261	49.48±18.86		-	38	47.10±22.32				
8b		19	37.1±11.82	325	46.08±18.32	73	45.41±17.11	39	51.15±25.40				
4b		19	50.79±17.42	74	44.46±21.38	33	52.84±24.39	53	42.34±22.97				
15b		26	33.46±12.55	254	39.17±17.24	86	42.67±21.89	32	59.69±25.52				
9b			-	291	43.76±20.44	66	42.88±18.52						
12b	60	16	55.62±17.31 [†]	286	55.77±17.99 [†]	67	57.24±16.59 [†]	23	62.39±16.57				
14a			-	296	62.97±17.03 [†]	80	61.75±19.60 [†]						
11b			-	279	61.13±18.80 [†]	73	62.67±14.91 [†]						
13b		43	51.05±17.75	214	47.90±19.60 [†]	43	49.19±18.93 [†]	33	49.85±16.79				
8a		19	48.33±13.28	355	64.77±17.48 [†]	74	63.92±19.62 [†]	38	55.51±16.69				
9a			-	289	52.37±18.41 [†]	67	51.72±19.72 [†]	36	63.82±23.71				
15a		46	48.26±16.34	270	52.81±18.31 [†]	90	53.78±21.19 [†]	55	52.27±22.56				
10a	90		-	357	69.12±18.04 [†]	52	68.65±19.50 [†]						
12a			-	357	71.27±15.98 [†]	71	72.32±15.76 [†]						
5a		50	59.40±19.91	330	67.24±17.13 [†]	33	62.27±20.50 [†]	41	62.32±21.33				
11a			-	384	73.98±17.21 [†]	79	72.27±16.97 [†]	19	73.42±19.22				
1a		123	61.90±19.93	280	60.69±19.12 [†]	34	53.37±19.51 [†]	197	54.43±18.57				
13a		72	54.03±19.66	250	54.00±19.54 [†]	57	51.14±19.80 [†]	35	54.43±18.14				
4a		19	50.79±17.42	218	54.22±21.51	38	57.11±24.95	44	56.59±23.42				

¹ Not including unfed larvae.

² Grouped according to time of availability of particles.

³ Mean possibly underestimated (see text).

Because of the high level of variation in percentage gut filled within each larval class, classes in which 'n' is less than 18 were considered too small for reliable analysis and were not included. The mean arcsine of percentage gut filled of larvae in each class is presented in Appendix F.

i) Ingestion among larval classes within experiments.

In most experiments there is no difference in ingestion (mean percentage gut filled) between larval classes within each experiment. Differences usually occurred when larvae were exposed to either fast or slow velocity or high or low [p] .

In the 30 min-experiments (fig. 2.3a) ingestion by large, and large parasitized larvae was significantly different in two experiments: #6 (P*) and #9b(P**). In #9b, larvae were exposed to fast velocity and high [p] , and the parasitized larvae ingested more than the healthy ones. In #6, velocity and [p] were low, and healthy larvae ingested more than parasitized ones.

In experiment #1b, small larvae ingested relatively more than medium larvae, and medium larvae more than large larvae. Similar results occurred in #1a (90-min experiment) between large and medium larvae, and large and small larvae (fig. 2.3c). Differences in ingestion between classes also occurred in the 30-min experiments #8b, #14b, and #15b in which [p] 's were high (45 particles/ml or greater); and in 30-min experiments #10b and #2, in which large larvae ingested more than medium larvae.

INGESTION OF PARTICLES BY
SIMULIUM VITTATUM ZETT.

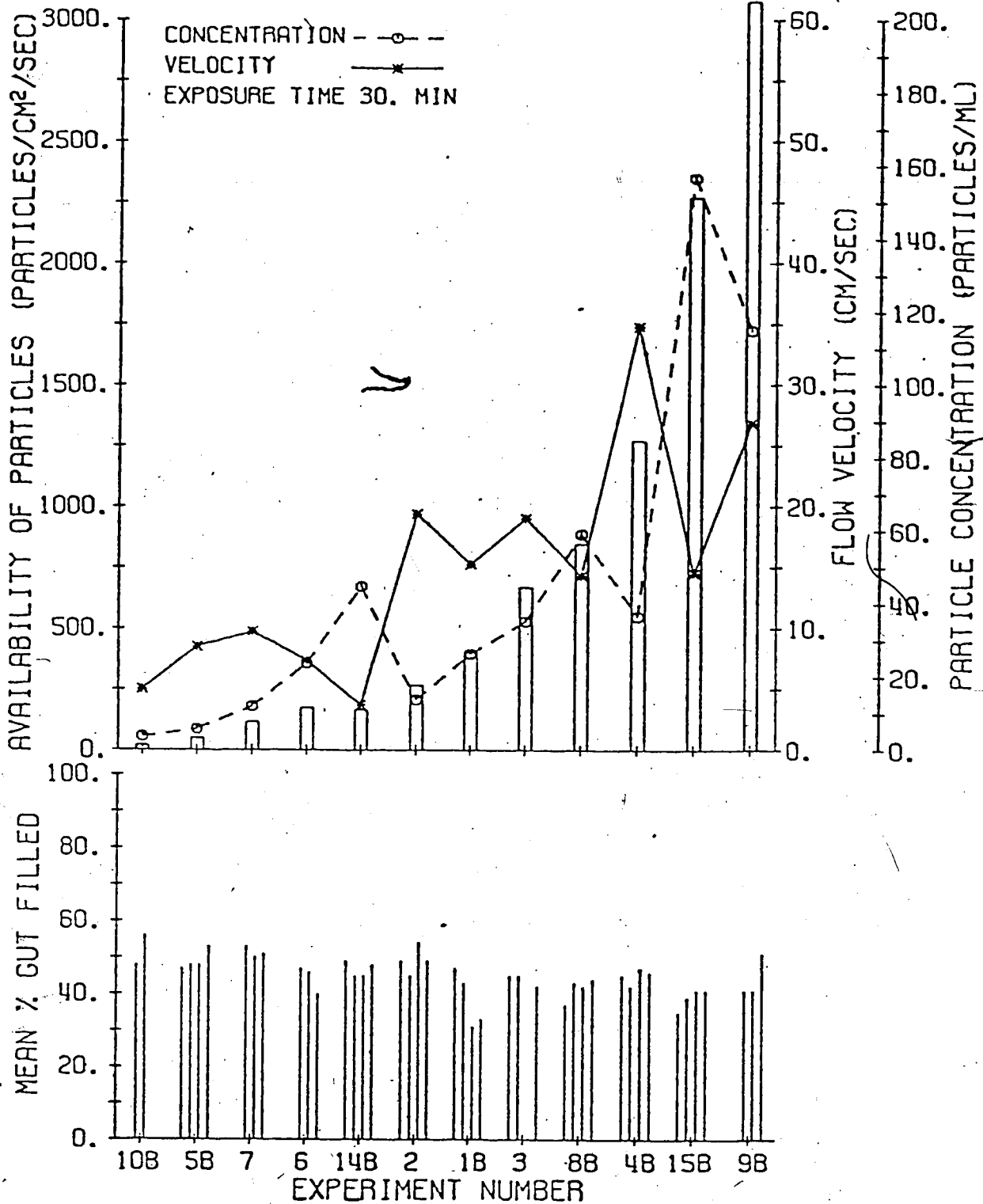

Fig. 2.3a. Mean (arcsine) percentage gut filled by larvae of 4 classes of Simulium vittatum Zett. after exposure to a range of availabilities of particles for 30 minutes. [In figs. 2.3a - 2.3c, the 4 lines of 'mean percentage gut filled' in each experiment represent, from left to right, those of small, medium, large, and large parasitized larvae respectively. In some experiments, small, large, and large parasitized larvae are not included (see text). In all figs. 2.3 and 2.4, histograms represent availabilities of particles].

INGESTION OF PARTICLES BY
SIMULIUM VITTATUM ZETT.

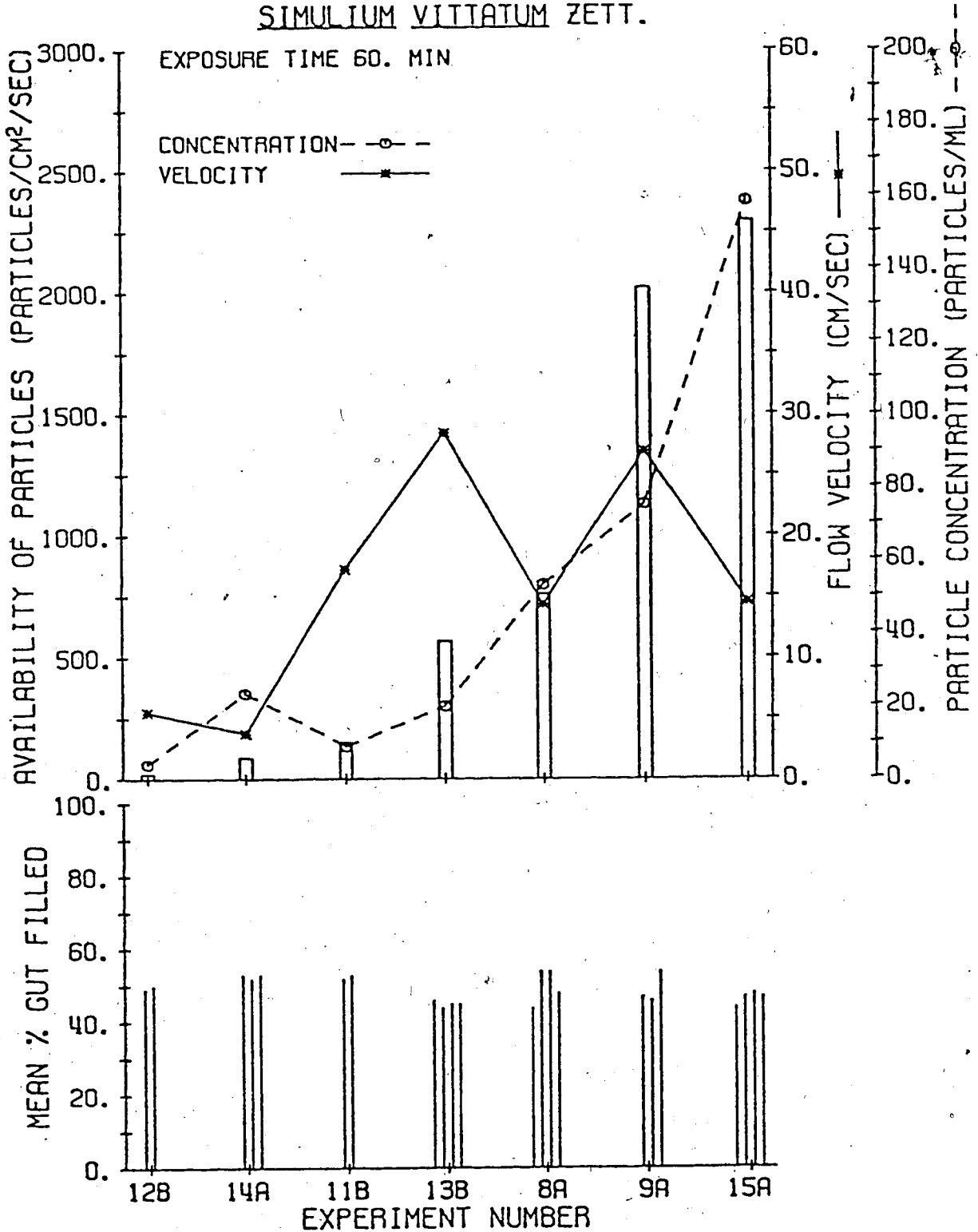

Fig. 2.3b. Mean (arcsine) percentage gut filled by 4 classes of larvae of Simulium vittatum Zett. after exposure to a range of availabilities of particles for 60 minutes.

INGESTION OF PARTICLES BY
SIMULIUM VITTATUM ZETT.

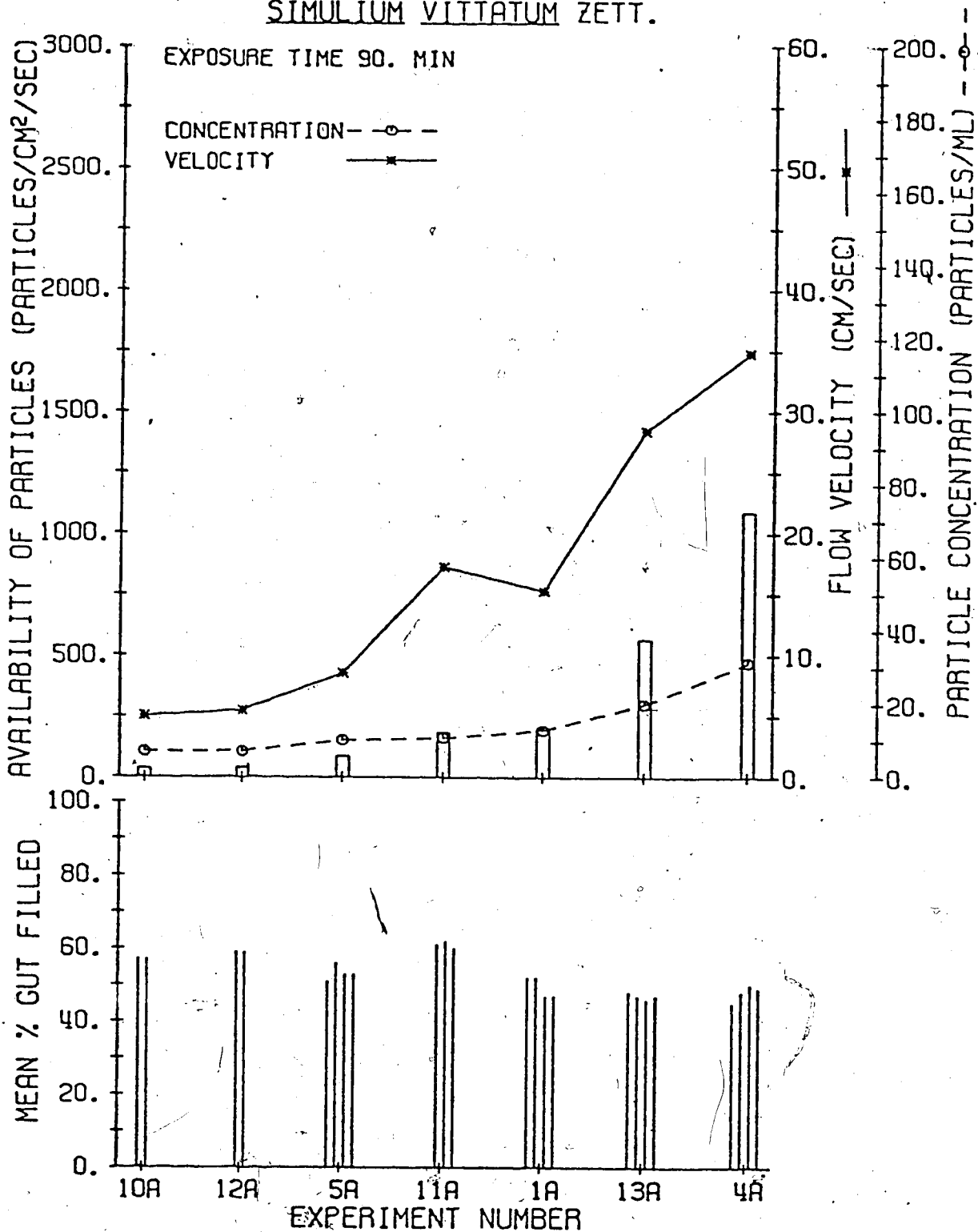

Fig. 2.3c. Mean (arcsine) percentage gut filled by 4 classes of larvae of Simulium vittatum Zett. after exposure to a range of availabilities of particles for 90 minutes.

In 60-min experiments (fig. 2.3b) differences in ingestion occurred only between healthy and parasitized larvae; these differences are not very significant (P^*). In #9a in which velocity was fast and [p] moderately high, large parasitized larvae ingested more than healthy ones, but in #8a, healthy larvae ingested more.

In 90-min experiments (fig. 2.3c), differences occurred not only in #1a, but also in #5a, in which medium larvae ingested more than small ones. In #5a velocity was slow and [p] was low.

ii) Ingestion within larval class among experiments.

Large larvae. During 30 minutes large larvae ingested most at particle availabilities of 18, 115, and 266 (fig. 2.3d). Ingestion decreased with availabilities of 49 and 174, and with higher availabilities of 668, 845, 1270, and 3075. Least ingestion occurred at an availability of 403, in #1b. During 60 minutes (fig. 2.3e) large larvae ingested most at availabilities of 86, 151, and 759; and less at lower (22) and higher (2014) availabilities. There was no significant difference between ingestion at availabilities of 22 and 2014, and at availabilities of 56 and 2014. During 90 minutes (fig. 2.3f) large larvae ingested most at availabilities of 34 and 184; less at 85; and least at 565 and 1087. Again, ingestion during #1a was exceptional.

In general, large larvae ingested optimally at availabilities of 100 to 200, exceptionally at 18 (#10b) and at 759 (#8a). They ingested less at low and high availabilities in which either [p] was high or velocity was fast. They ingested least at high availabilities of

INGESTION OF PARTICLES BY
SIMULIUM VITTATUM ZETT.

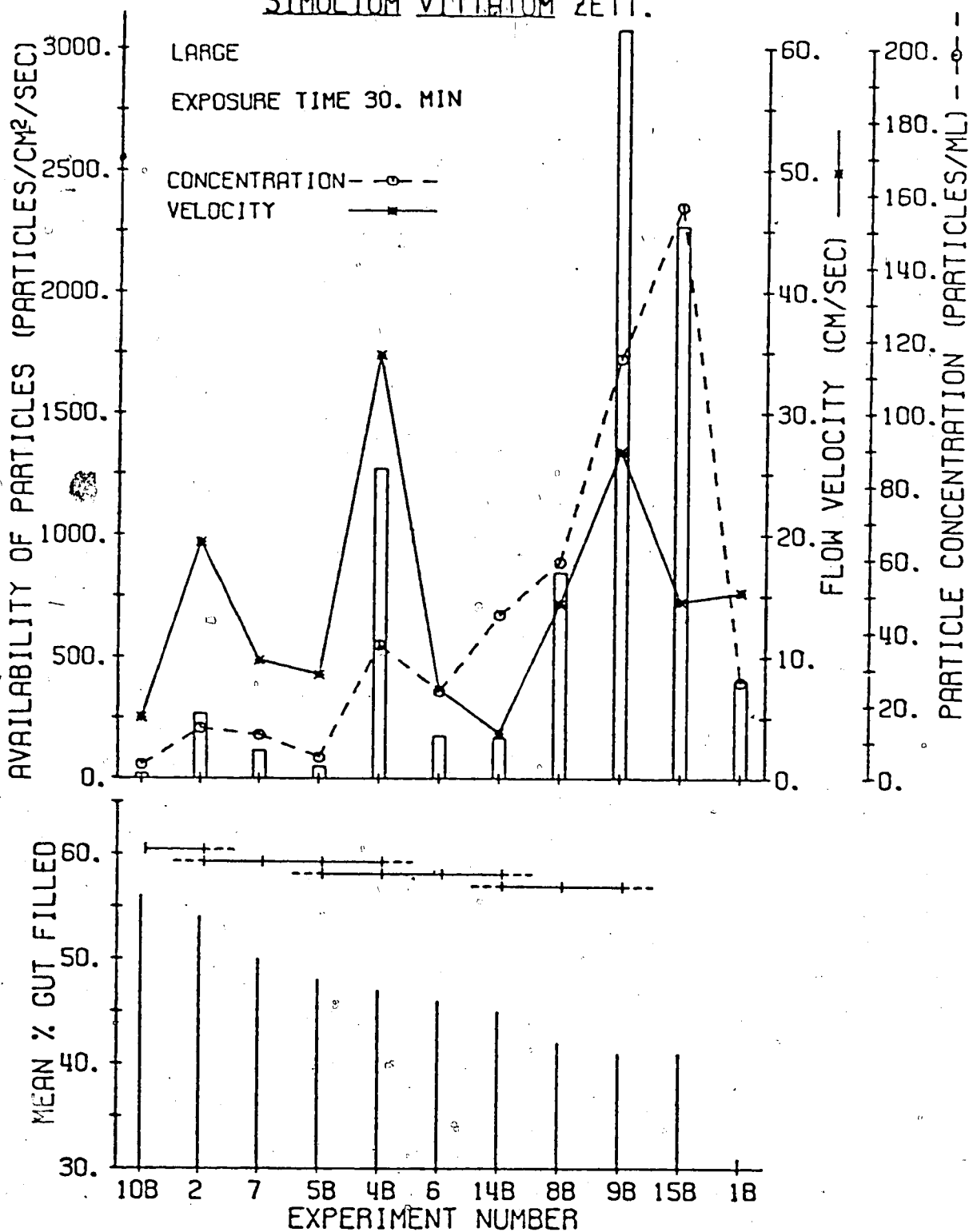

Fig. 2.3d. Mean (arcsine) percentage gut filled by large larvae of Simulium vittatum Zett. after exposure to a range of availabilities of particles for 30 minutes. [In figs. 2.3d - 2.3o, solid lines above mean percentage gut filled depict those experiments in which there is no significant difference between means of percentage gut filled].

INGESTION OF PARTICLES BY
SIMULIUM VITTATUM ZETT.

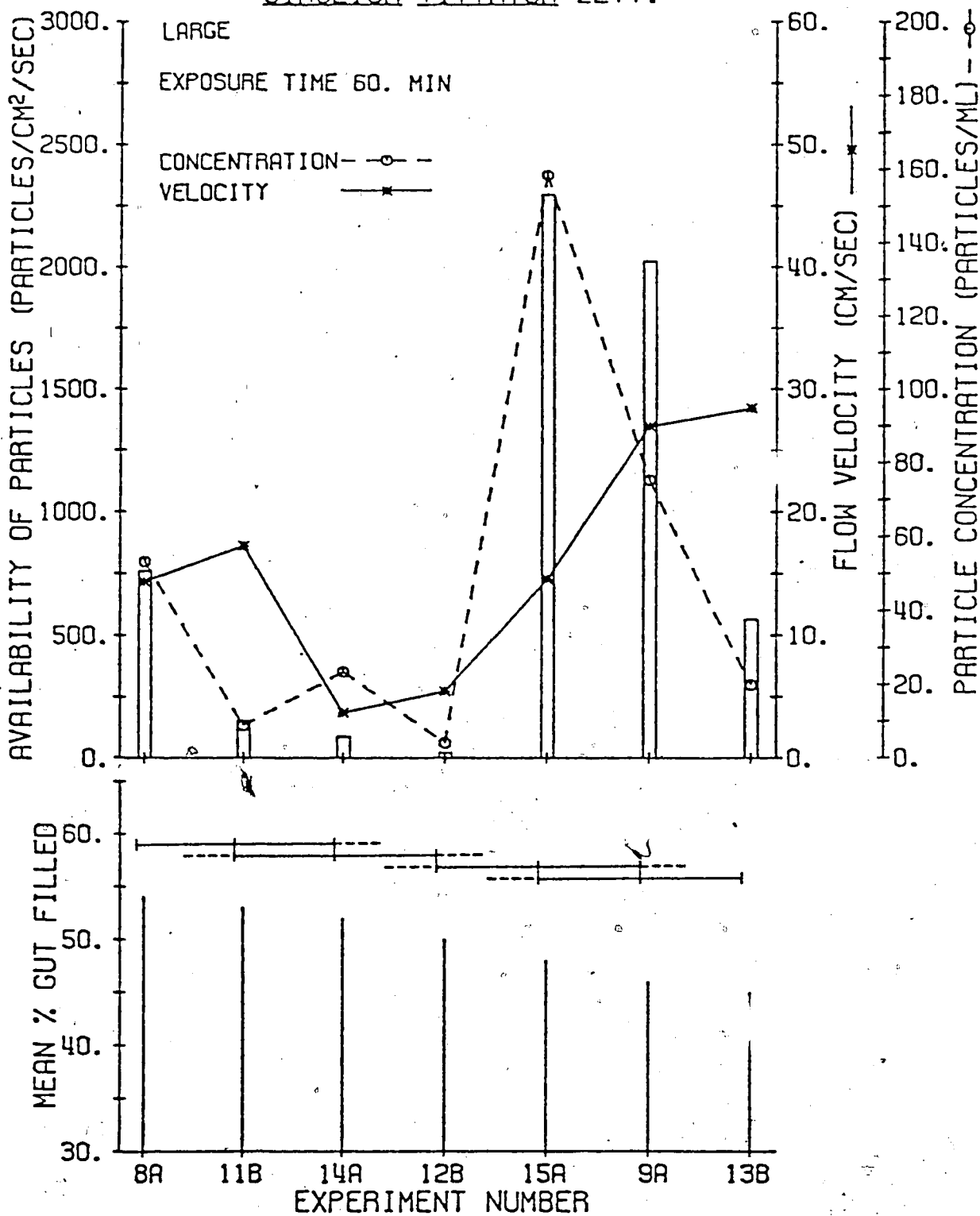

Fig. 2.3e. Mean (arcsine) percentage gut filled by large larvae of Simulium vittatum Zett. after exposure to a range of availabilities of particles for 60 minutes.

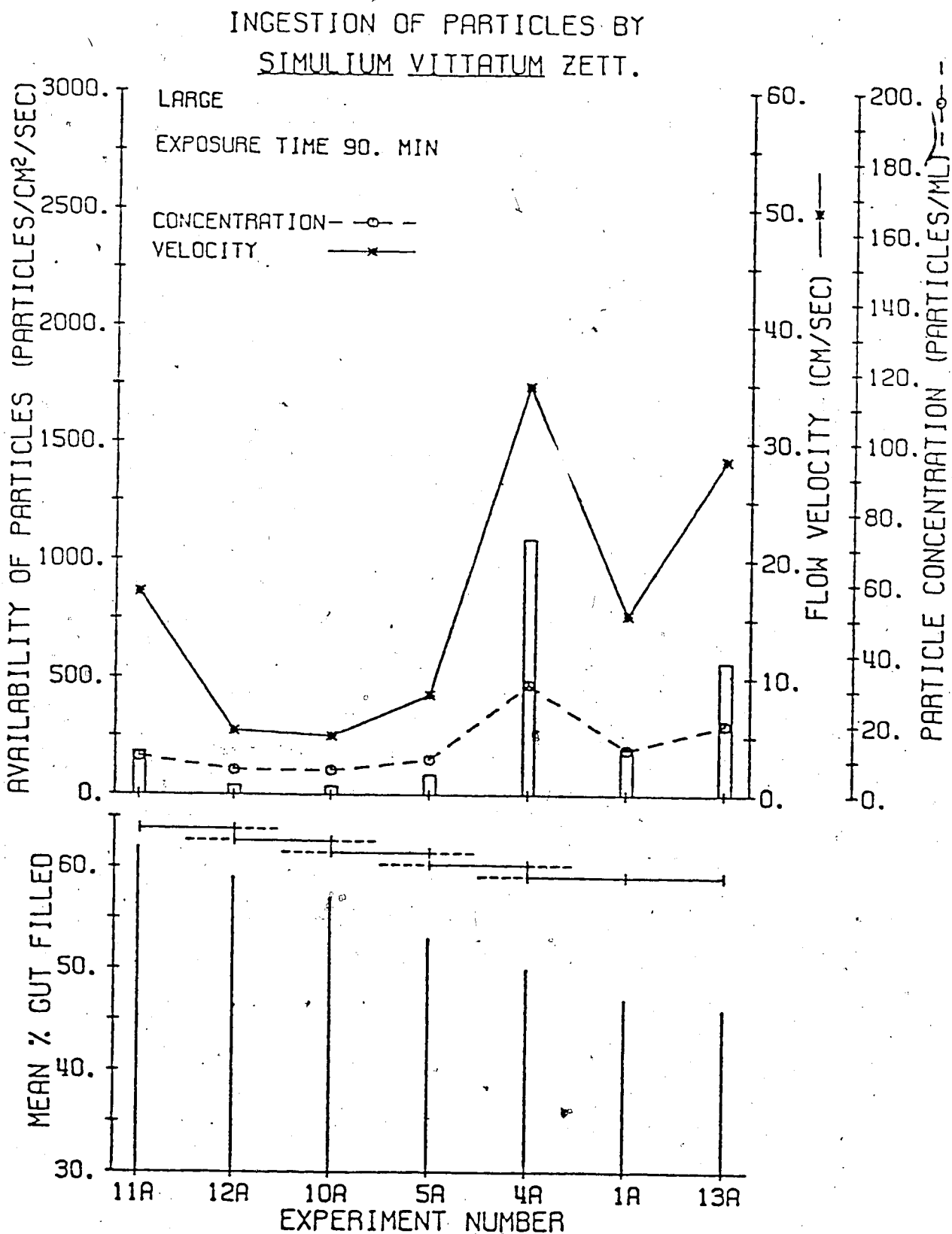

Fig. 2.3f. Mean (arcsine) percentage gut filled by large larvae of Simulium vittatum Zett. after exposure to a range of availabilities of particles for 90 minutes.

2000 - 3000, and not well during experiments #1a and #1b.

Medium larvae. After 30 minutes (fig. 2.3g) medium larvae ingested more at a particle availability around 115 than at any other availability to which they were exposed. Their ingestion decreased with decreasing availability (18, 49) and with increasing availability (165, 173, 266, and 668). Medium larvae ingested least at an availability of over 2000 (2268). They fed equally at availabilities of 403, 845, 1270, and 3075, when they were exposed to either high [p] or fast velocity.

Ingestion over 60 minutes (fig. 2.3h) and 90 minutes (fig. 2.3i) by medium larvae was similar to that by large larvae, with a maximum ingestion around an availability of 100 - 200, and decreasing with higher availability. During 60-min experiments, larvae of both medium and large classes ingested well during experiment #8a at an availability of 759, and not very well during #13b, with an availability of 564. This suggests that a velocity of 28 cm/sec and a [p] of 20/ml is less satisfactory for ingestion than a velocity of 14.3 cm/sec and a [p] of 53/ml. During 90-min experiments, medium larvae ingested more at availabilities of 34 - 85 and over 200. Again, larvae did not ingest well during #1a.

Small larvae. Fewer groups of small larvae were available for analysis. These larvae tended to ingest equally under a variety of conditions. After 30 minutes, they ingested equally at availabilities from 49 - 1270 (fig. 2.3j), and ingested less at availabilities of

INGESTION OF PARTICLES BY
SIMULIUM VITTATUM ZETT.

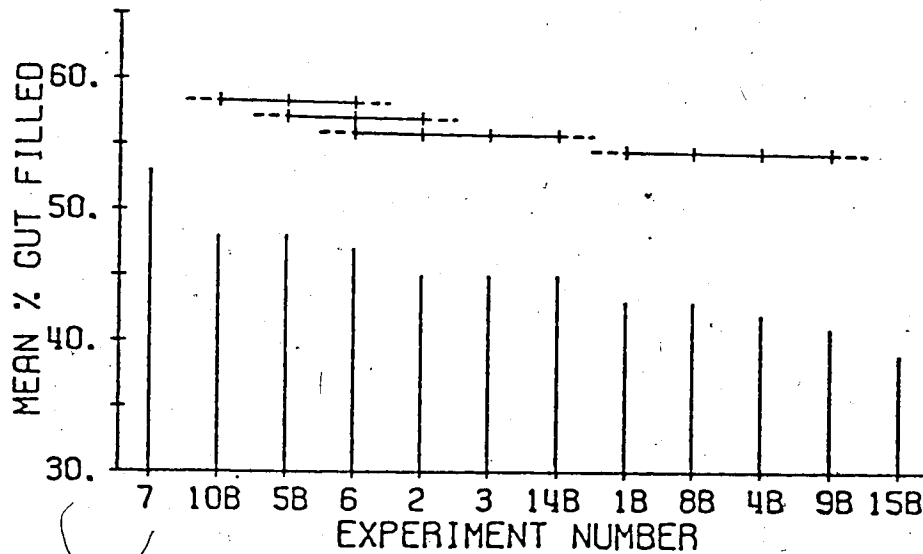
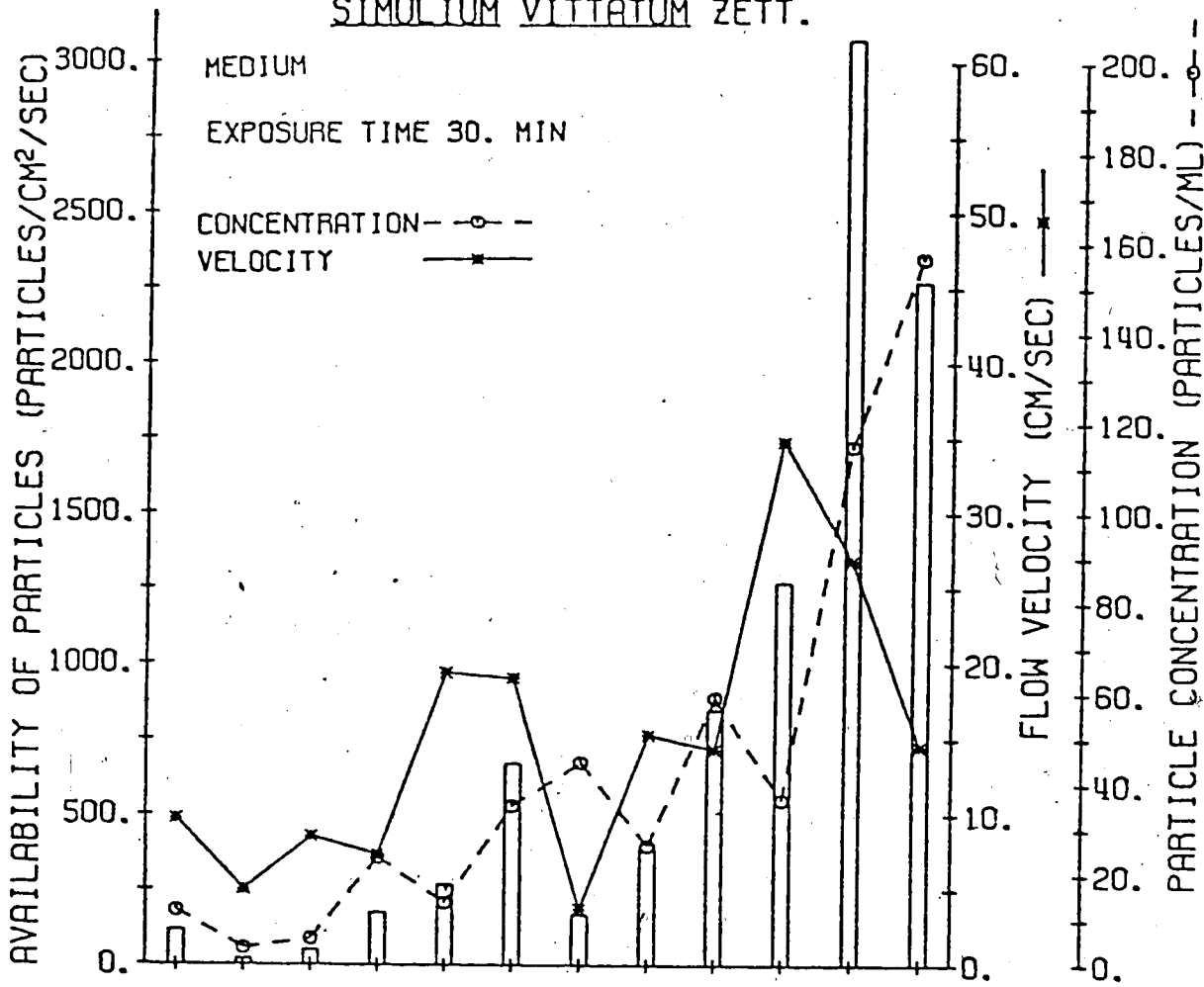

Fig. 2.3g. Mean (arcsine) percentage gut filled by medium larvae of Simulium vittatum Zett. after exposure to a range of availabilities of particles for 30 minutes.

INGESTION OF PARTICLES BY
SIMULIUM VITTATUM ZETT.

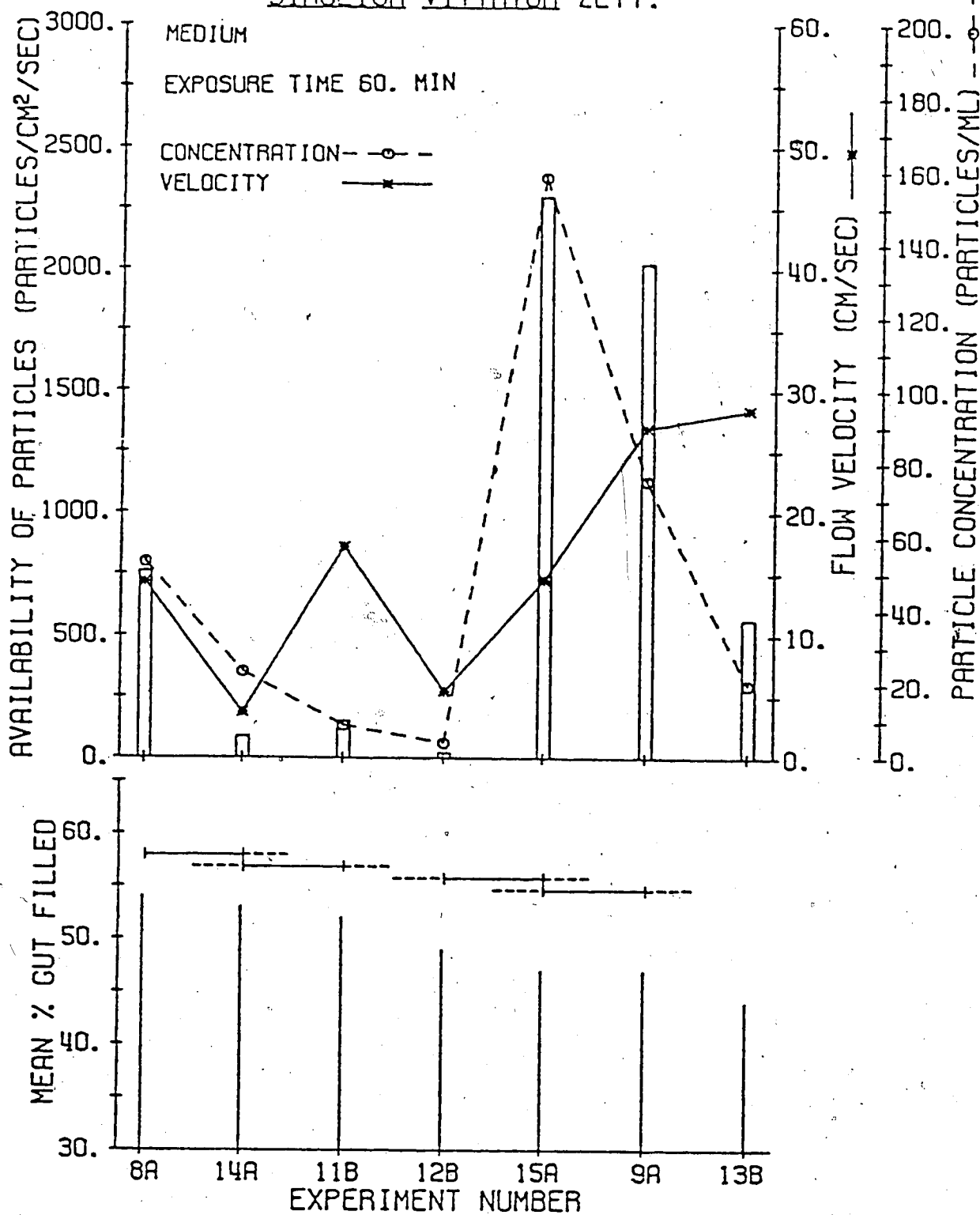

Fig. 2.3h. Mean (arcsine) percentage gut filled by medium larvae of Simulium vittatum Zett. after exposure to a range of availabilities of particles for 60 minutes.

INGESTION OF PARTICLES BY
SIMULIUM VITTATUM ZETT.

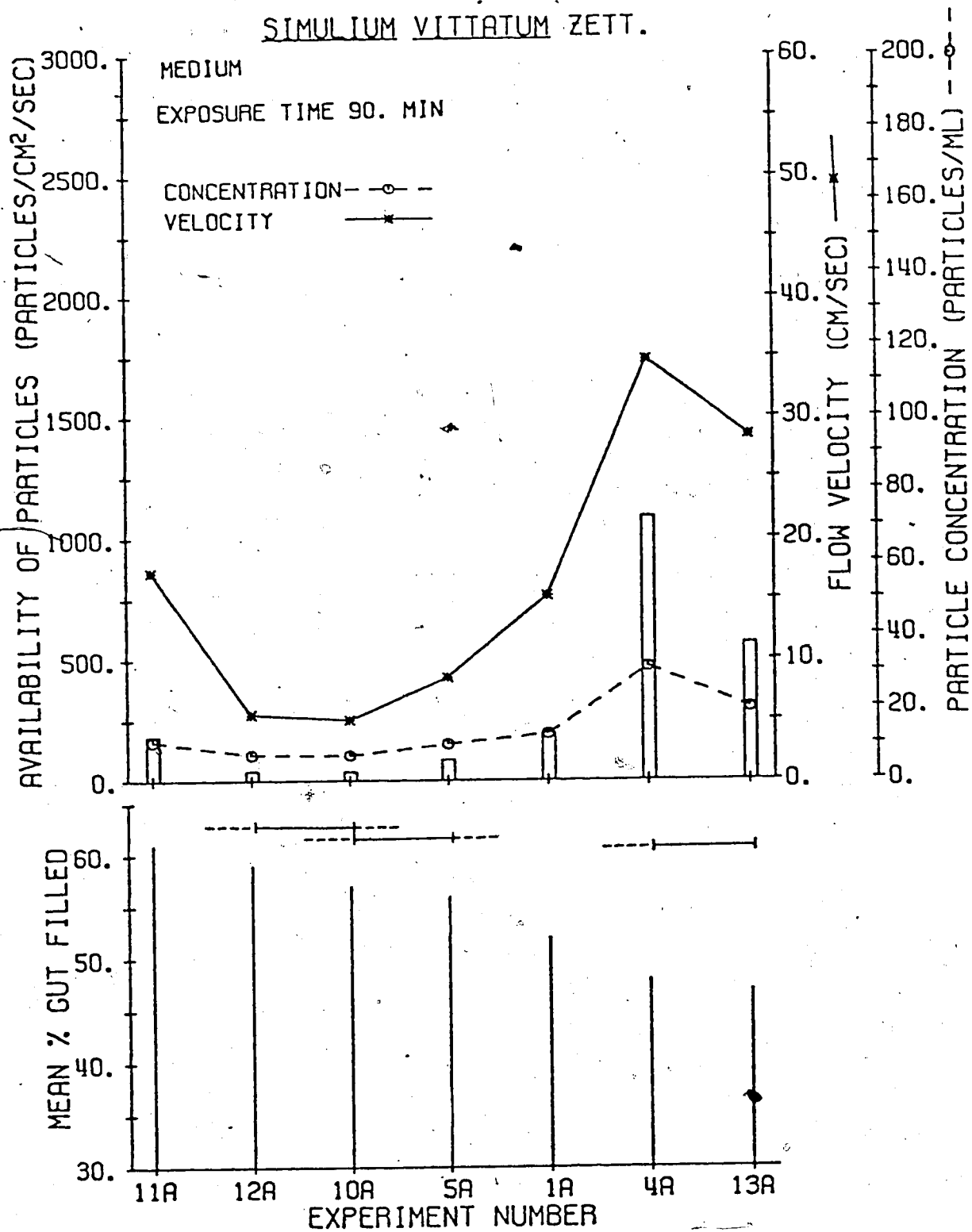

Fig. 2.31. Mean (arcsine) percentage gut filled by medium larvae of Simulium vittatum Zett. after exposure to a range of availabilities of particles for 90 minutes.

INGESTION OF PARTICLES BY SIMULIUM VITTATUM ZETT.

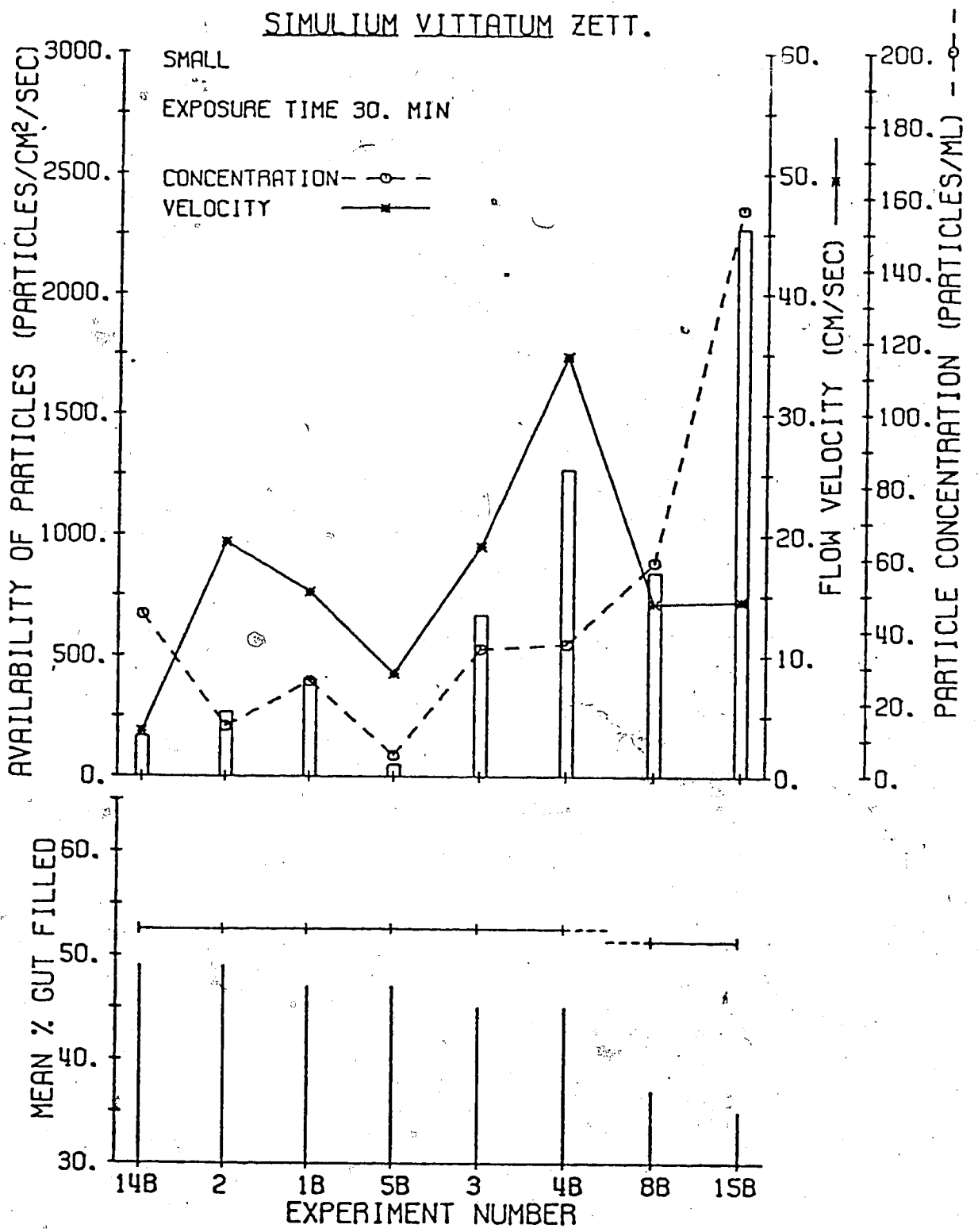

Fig. 2.3j. Mean (arcsine) percentage gut filled by small larvae of Simulium vittatum Zett. after exposure to a range of availabilities of particles for 30 minutes.

INGESTION OF PARTICLES BY SIMULIUM VITTATUM ZETT.

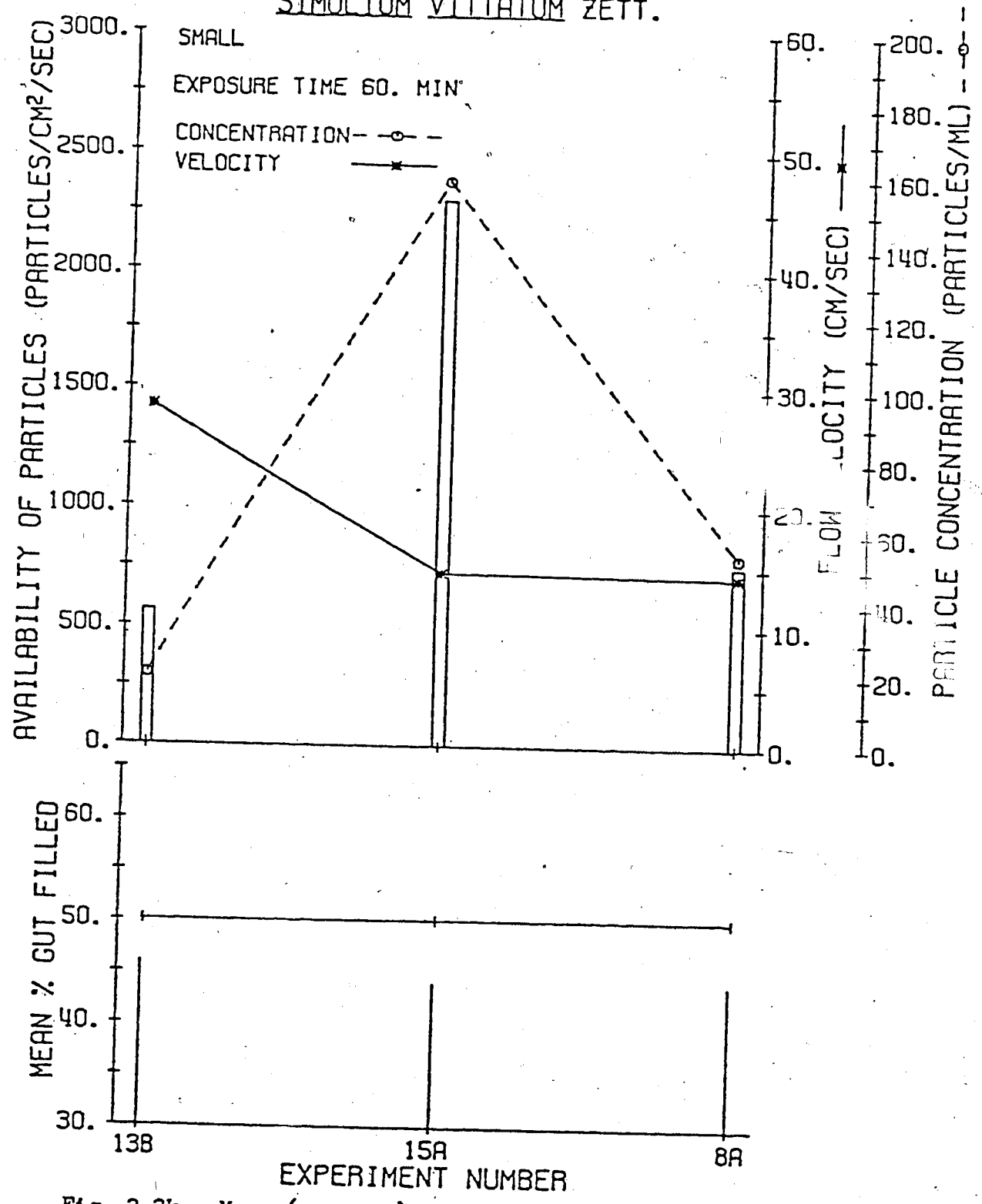

Fig. 2.3k. Mean (arcsine) percentage gut filled by small larvae of Simulium vittatum Zett. after exposure to a range of availabilities of particles for 60 minutes.

INGESTION OF PARTICLES BY
SIMULIUM VITTATUM ZETT.

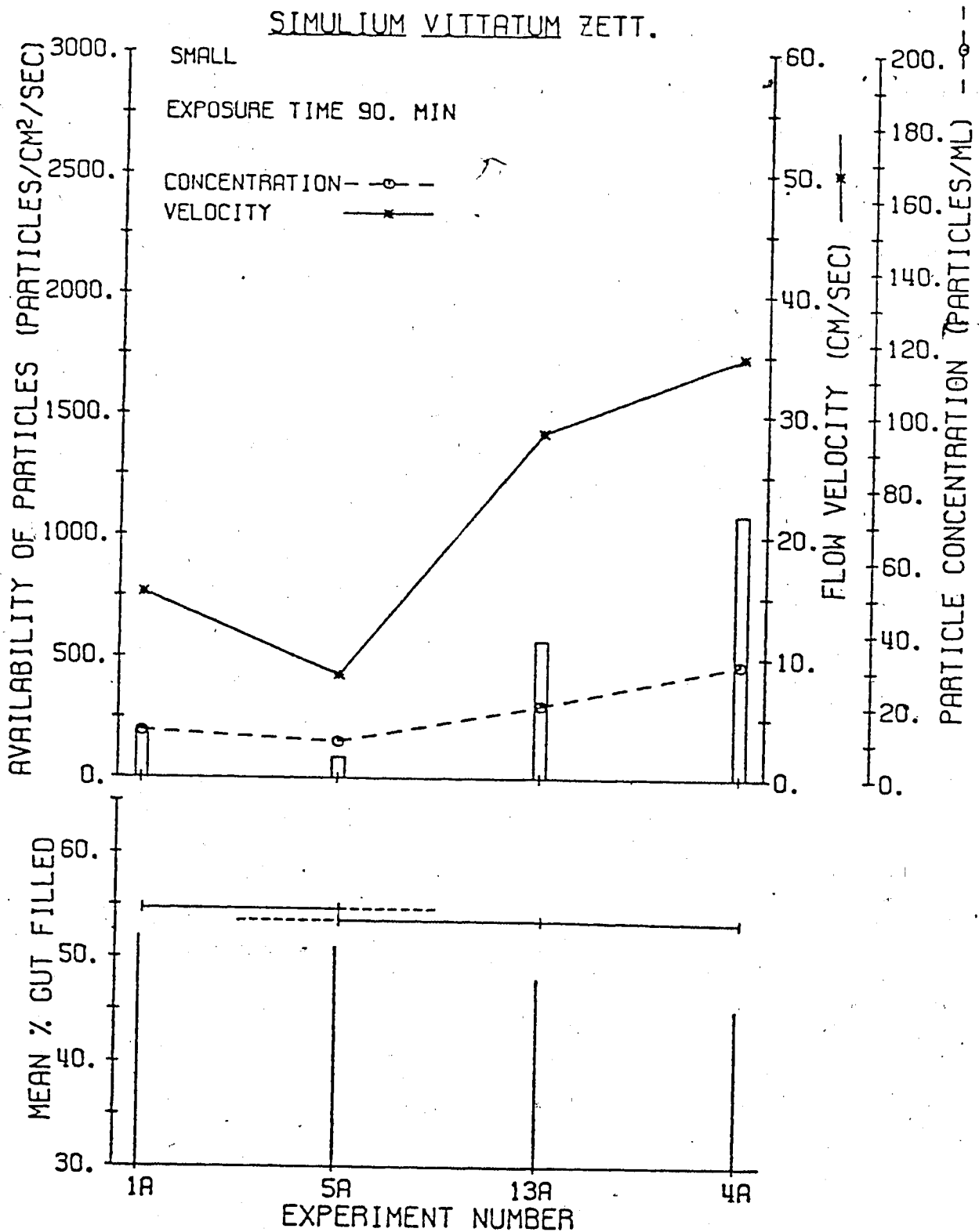

Fig. 2.31. Mean (arcsine) percentage gut filled by small larvae of Simulium vittatum Zett. after exposure to a range of availabilities of particles for 90 minutes.

845 and 2268. As in other classes of larvae, small larvae ingested well during experiment #4b, with a high availability, in fast velocity and moderately high [p] .

After 60 minutes (fig. 2.3k) small larvae ingested equally at all three availabilities to which they were exposed (564 - 2294). After 90 minutes (fig. 2.3l) they ingested most at availabilities of 85 and 196, and equally but less at availabilities of 85, 565, and 1087.

Large parasitized larvae. During 30 minutes (fig. 2.3m) large parasitized larvae ingested equally at lower availabilities of 49, 115, 165, and 266, and at higher availabilities of 1270 and 3075. They ingested less well at availabilities of 668, 845, and 2268. They ingested less than might be expected at availabilities of 175 (#6) and 402 (#1b). These results suggest that large parasitized larvae are more tolerant of faster velocities and higher [p] . This tolerance is also apparent in the results of #9a (after 60 minutes, fig. 2.3n) and #9b, but not in #4b in which velocity was fast but [p] lower.

After 60 minutes (fig. 2.3n) large parasitized larvae ingested most at availabilities of 86 and 2014, less at availabilities of over 500 - 2294. After 90 minutes (fig. 2.3o) large parasitized larvae ingested most at availabilities of 34, 184 and 85; less at an availability of 1086; and least at 196 and 565. Again, as in the other larval classes, large parasitized larvae did not ingest well during experiments #1a, b.

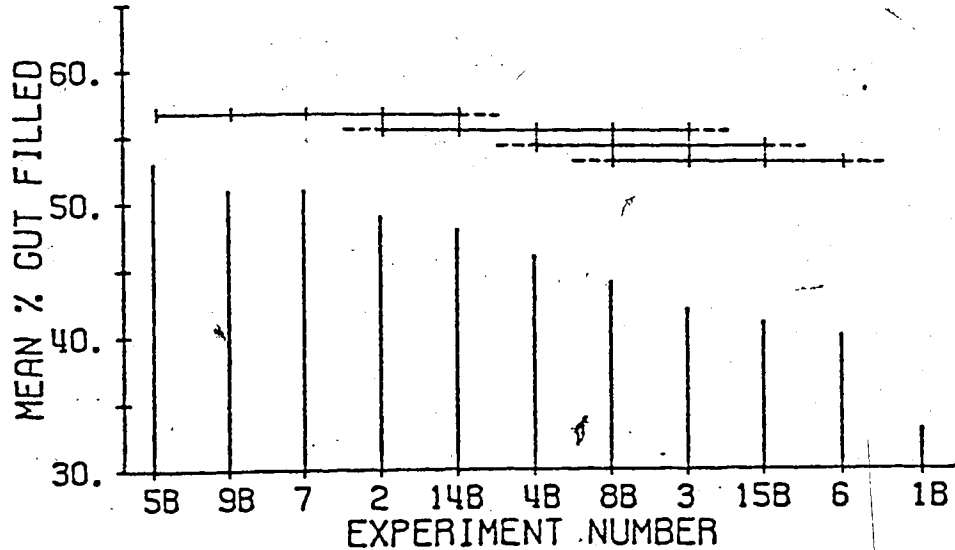
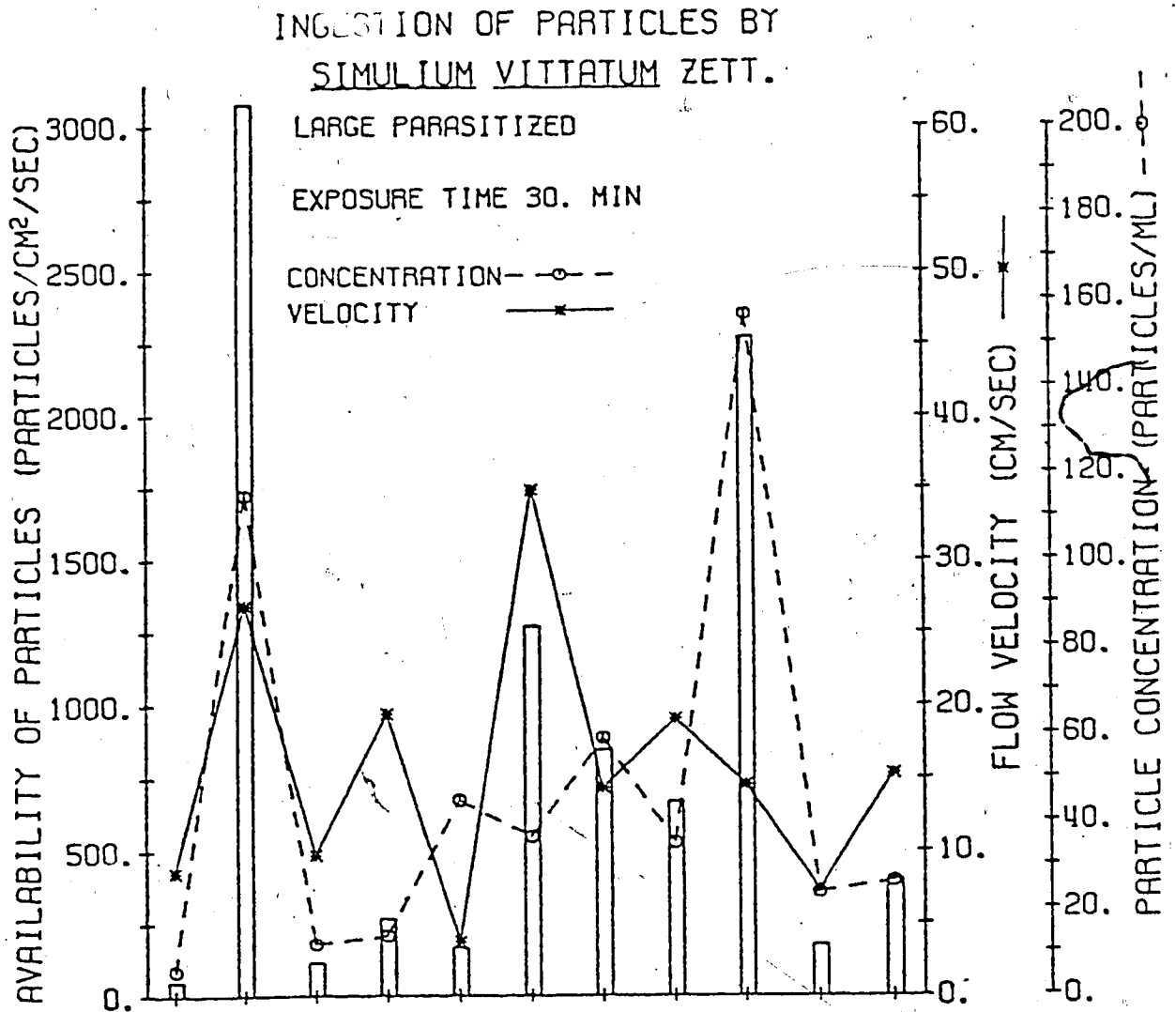

Fig. 2.3m. Mean (arcsine) percentage gut filled by large parasitized larvae of Simulium vittatum Zett. after exposure to a range of availabilities of particles for 30 minutes.

INGESTION OF PARTICLES BY
SIMULIUM VITTATUM ZETT.

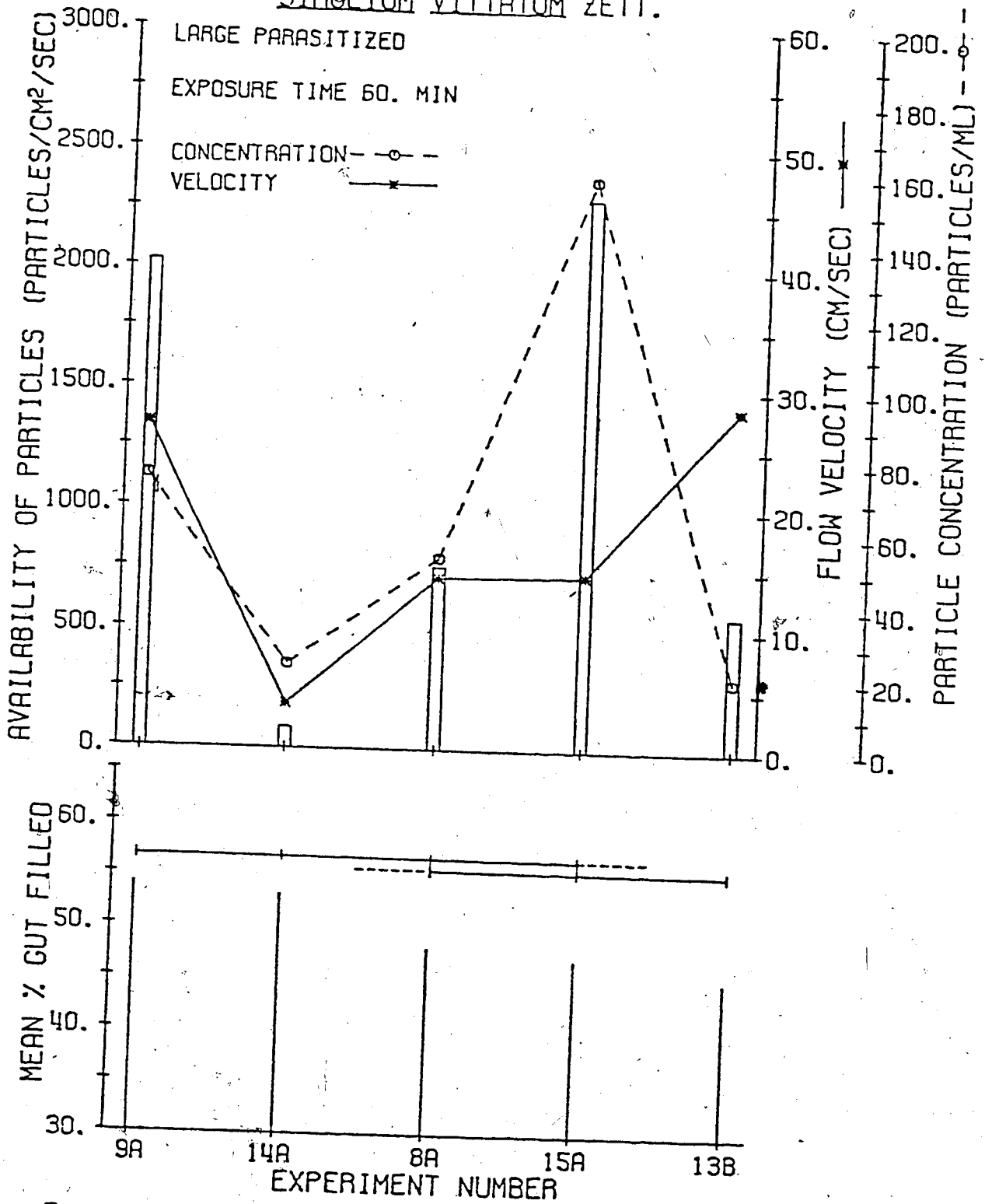

Fig. 2.3n. Mean (arcsine) percentage gut filled by large parasitized larvae of Simulium vittatum Zett. after exposure to a range of availabilities of particles for 60 minutes.

INGESTION OF PARTICLES BY
SIMULIUM VITTATUM ZETT.

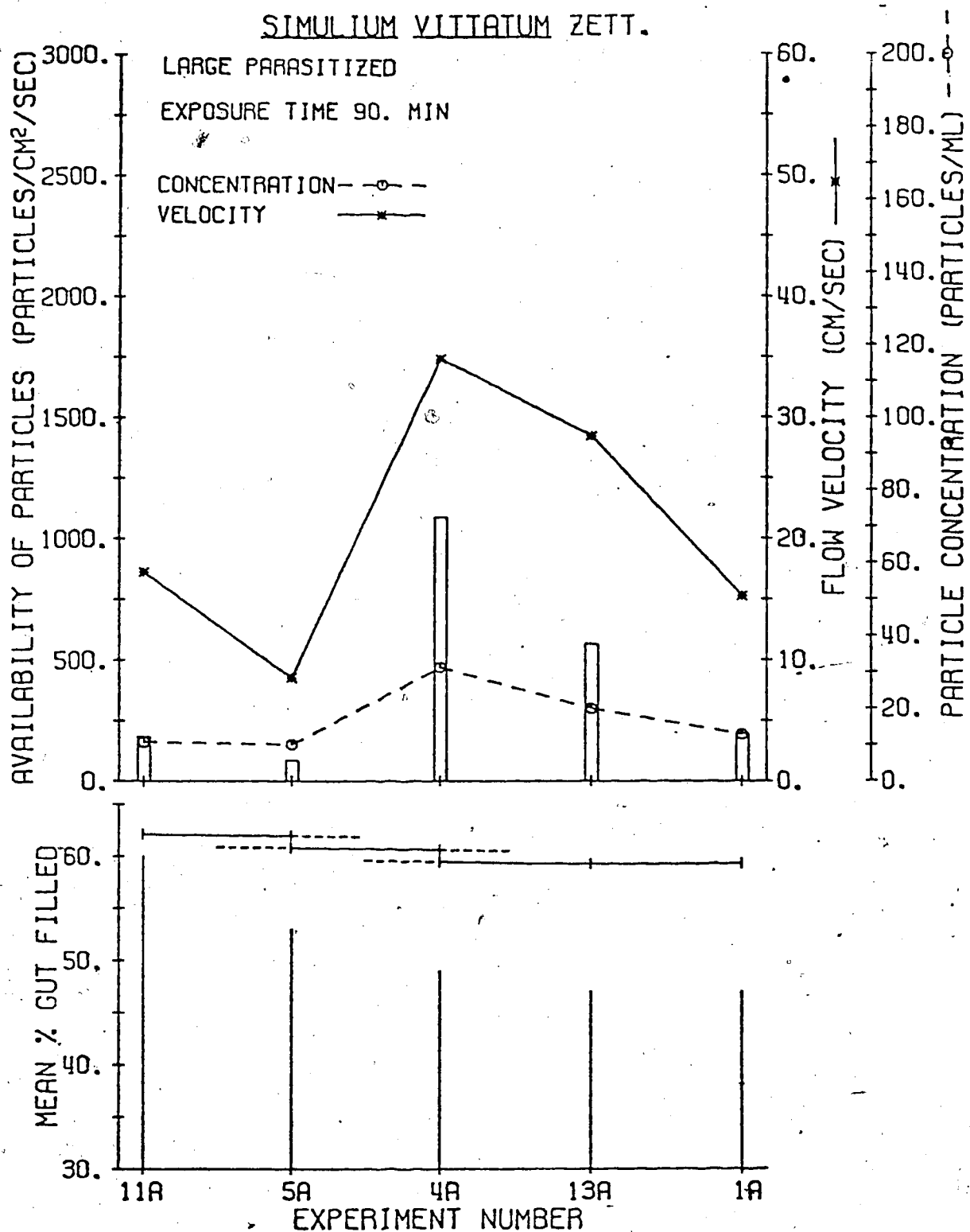

Fig. 2.30. Mean (arcsine) percentage gut filled by large parasitized larvae of Simulium vittatum Zett. after exposure to a range of availabilities of particles for 90 minutes.

iii) Comparison of ingestion after grouping experiments.

In comparisons of grouped experiments only one factor is considered at a time. Because the conditions of one factor vary over the conditions of a second factor, and because both factors influence ingestion, the comparisons are subject to bias. In a comparison between ingestion by larvae exposed to two conditions of one factor, for example, velocity, the conditions of the second factor, that is [p], may not be the same.

To determine separate influences of velocity and [p] on ingestion by larvae, comparisons on ingestion were made after grouping experiments according to velocity and according to [p]. Experiments were grouped according to velocity as follows:

- slow velocity, less than 10 cm/sec.
- moderate velocity, 10 - 16 cm/sec.
- fast velocity, greater than 16 cm/sec.

Experiments were grouped according to [p] as follows:

- low, less than 20 particles/ml.
- moderate, 20 - 80 particles/ml.
- high, more than 80 particles/ml.

The limits of these categories were chosen arbitrarily.

Comparisons of ingestion between larval classes after grouping according to velocity:

Comparisons of ingestion by larvae in each class in experiments grouped according to velocity show that after 30 minutes there are no differences (P***) in ingestion between classes of larvae exposed to slow velocities. Under moderate velocities, ingestion by larvae was similar between classes with the exception of small larvae which

ingested significantly less (P**) than other larvae. Under fast velocities medium larvae ingested significantly less (P*) than larvae of other classes.

Comparisons of ingestion within larval class after grouping according to velocity:

Within each larval class, at slow velocities, larvae ingested equally at all availabilities ([p] from 4 - 48/ml). At moderate velocities, larvae of all classes ingested less at higher [p] (except in #1a). At fast velocities [p] had no influence on ingestion with the exception of ingestion by medium larvae which was greater (P**) when larvae were exposed to lower [p] .

At 60 and 90 minutes, there is no difference in ingestion between larval classes when larvae were exposed to slow, medium, or fast velocities. There are too few experiments to make comparisons of ingestion within larval class of larvae exposed to the same velocity.

Comparisons of ingestion within larval class among velocities show that, after 30 minutes, medium and small larvae ingested significantly less in fast and moderate velocities than in slow velocities (P** and P*, respectively). Large larvae ingested significantly different (P**) amounts in all three velocities: most in slow velocity and least in moderate velocity. Large parasitized larvae ingested equally in slow and fast velocities, and least (P**) in moderate velocity.

At 60 and 90 minutes, large and medium larvae ingested equally in moderate and slow velocities and more than in fast velocity (P**, P*, respectively). Large parasitized larvae ingested equally in fast and moderate velocities. (There were not enough parasitized larvae feeding in slow velocities for reliable analysis.)

Comparisons of ingestion between larval classes after grouping according to particle concentration:

Comparisons of ingestion after grouping experiments according to [p] also showed that all classes of larvae tend to ingest proportionally the same amount within each time period when exposed to similar [p]. In only one case was there any significant difference in ingestion: large parasitized larvae ingested more than large healthy larvae when exposed to high mean [p] for 30 minutes (P*). This result is due to differences in ingestion which occurred in experiment #9b (sect. 2.3.3.2.i).

Comparisons of ingestion within larval class after grouping according to particle concentration:

Comparisons within larval class within time periods show that ingestion by large and medium larvae under low [p] is greater than that under moderate [p] (P***, P***, respectively), which is greater than that under high [p] (P***, P**, respectively). The same results occur for small and large parasitized larvae at 30 minutes and for large parasitized larvae at 60 minutes. However, there is no significant difference in ingestion by small larvae at 60 and 90 minutes, and by large parasitized larvae at 90 minutes when exposed to different [p]'s. The range of experimental conditions is not sufficient to consider

differences within [p] or between [p] 's within velocity.

iv) Ingestion within 'doubled' experiments.

Comparisons of ingestion, within larval classes were made between parts of each 'doubled' experiment (table 2.5). Velocity is the same for each part but time and [p] is not. In the shorter part of each pair of experiments, larvae were exposed to a higher mean [p]. Larvae of all classes except large parasitized larvae tended to ingest more the longer they were exposed to particles. However, in some doubled experiments large and small larvae, as well as large parasitized larvae, ingested similarly in both feeding periods despite 30 or 60 minute differences in exposure time. There were no differences in ingestion by large larvae in four experiments (#4a, b; #5a, b; #10a, b; #13a, b) and by small larvae in two experiments (#5a, b; #13a, b). Large parasitized larvae ingested significantly greater amounts during the longer time period in only two of the doubled experiments (#1a, b; #15a, b).

The longer exposure periods lead to a lower mean [p], and this in turn leads to greater ingestion. As shown in comparisons of ingestion within larval classes (sect. 2.3.3.2.ii), large parasitized larvae are not as sensitive to high [p] as are larvae of other classes, and ingest as well under high [p] for a shorter time as under lower [p] for a longer time. In experiments in which large and small larvae ingested equally in both time periods, [p] was very similar for both time periods and the larvae did not ingest more during the longer exposure period.

Table 2.5. Ingestion¹ by larvae of *Simulium vittatum* within 'doubled' experiments

Expt.	Time	Larval Class			
		Small (n)	Medium (n)	Large (n)	Large P. (n)
1a	90	52.35* (58)	51.97** (211)	45.79** (43)	47.45*** (212)
1b	30	47.24 (123)	43.03 (280)	30.95 (34)	33.30 (197)
4a	90	45.40 (19)	47.73** (218)	49.65 (38)	49.31 (44)
4b	30	45.46 (19)	41.82 (74)	47.12 (33)	46.21 (39)
5a	90	50.73 (50)	55.93*** (330)	53.13 (33)	52.99 (41)
5b	30	46.60 (48)	48.00 (311)	48.41 (34)	53.14 (42)
8a	60	43.98** (19)	54.42*** (355)	53.92*** (74)	48.47 (38)
8b	30	37.24 (19)	42.74 (325)	42.29 (73)	43.59 (38)
9a	60		46.52*** (289)	46.03** (67)	53.67 (36)
9b	60		41.32 (291)	40.72 (66)	51.39 (37)
10a	90		57.32*** (357)	57.02 (52)	
10b	30		47.80 (318)	55.74 (49)	
11a	90		60.66*** (384)	62.08*** (79)	60.19 (19)
11b	60		52.06 (279)	52.83 (73)	55.19 (15)
12a	90		58.53*** (357)	59.27*** (71)	
12b	60		48.71 (286)	49.60 (67)	
13a	90	47.75 (72)	47.46*** (250)	45.79 (57)	47.45 (35)
13b	60	45.79 (43)	43.72 (214)	44.66 (43)	44.85 (33)
14a	60	47.89 (16)	53.15*** (296)	52.45*** (80)	53.14 (23)
14b	30	49.09 (58)	45.42 (208)	45.03 (43)	40.41 (50)
15a	60	44.09*** (46)	46.97*** (270)	47.53*** (90)	46.71* (55)
15b	30	35.05 (26)	38.60 (254)	40.62 (86)	40.61 (53)

¹ Mean arcsine percentage gut filled.

*, **, *** denote significant differences in ingestion.

v) Comparison of mean percentage gut filled between larval classes.

Duncan's New Multiple Range Test was applied after analysis of variance was done to determine if the mean ingestion by larvae differed between classes for each experiment (Appendix G, Table II). The means tested are means of the arcsine of square root of percentage gut filled. This test of significance among means paralleled significance between variances according to anova 2, with two exceptions: in experiment #8b (30 minutes), there is no significance between mean ingestion by large and small larvae; and in #3 (30 minutes) the mean ingestion by large healthy larvae is greater (P**) than that of large parasitized larvae. Thus all classes of larvae, with few exceptions, ingest proportionally equal amounts when exposed to the same feeding conditions.

vi) Proportion of larvae which did not feed.

Numbers of unfed larvae in each class are considered according to feeding period. Samples with less than 18 larvae are considered too small for reliable analysis and are not included. The proportion of larvae which did not feed in each experiment is expressed as a percentage (figs. 2.4a - c and table 2.2). To determine whether the percentage of unfed larvae in each class varied between experiments and between classes, tests of independence using multiway-tables (G-test) were applied. Because some samples of small and large parasitized larvae were too small for reliable analysis, tests were carried out in two groups: large, medium, and small larvae; and large, medium, and large parasitized larvae. The results of the tests are presented in Appendix H.

In both sets of larval classes within each feeding period, there is significant association between all three factors: larval class, 'feeding'¹, and experimental conditions. There is significant association between the three pairs of factors: 1) feeding and experiment, 2) feeding and larval class, and 3) experiments and larval class. Thus the percentage of unfed larvae in each class is dependent on larval class and on experimental conditions. The G-test also shows that the interaction between these three factors is not significant, thus the association between any two factors does not vary with the third factor.

The association between factors was partitioned into components and analysed. Feeding within each larval class and the ratio of larval classes within those feeding were analysed according to Kullback (1968). When interaction between the three factors was negative, an alternative method of partitioning the data was carried out. The independence between larval class and experiment conditional on feeding, and between feeding and experiment conditional on larval class, was analysed for the two sets of larval classes for each time period. Feeding within larval class is dependent on experiment, with the exception of large parasitized larvae exposed for 60 minutes, and varied among larval classes (Appendix H). Variation of feeding over experiments was greatest among medium larvae and least among large parasitized larvae. Medium larvae are more sensitive to differences

¹ In this section, 'feeding' refers to the proportion of larvae in the population which fed. Thus an increase in feeding is an increase in the proportion of the population which ingested particles.

between experiments; large parasitized larvae, least sensitive.

The association of larval class and experiment, i.e. availability of particles, is greater among larvae which fed than among unfed larvae. This association is not a causal relationship but rather reflects changes in the population of larvae per class in the total population. Availability of particles was probably influenced to some extent by proportions of larval class in the flume populations. Although larvae in all classes ingest proportionally the same amount (sect. 2.3.3.2.), the absolute numbers of particles ingested varies with class. For example, if the particles are of similar size, large larvae require a greater number of particles to fill their guts than do small larvae. Thus differences in proportions of larval class comprising the total flume populations between experiments may be related to differences in rate of reduction of $[p]$. Evidence for this is the closer association of percentage of fed larvae to experiments rather than of unfed larvae to experiments. Yet there is no relationship between mean $[p]$ and the numbers of larvae in each class or total numbers of larvae in the flume (sect. 2.3.1.). Mean $[p]$ is determined by many factors and there is not sufficient evidence to show that the association of experiment (availability of particles) to numbers of larvae per class is real.

Where interaction between larval class, feeding, and experiment is negative, alternative partitioning showed significant interactions (Appendix G, 30 and 90 minutes). Differences among experiments influenced feeding differentially between larval class at 30 and 90

minutes. Again, there is significant association of experiments to feeding, conditional on larval class. This method of partitioning does not provide a means for subdividing into larval classes or into percentage of fed or unfed larvae.

The percentage of unfed larvae varies with class, that is, decreasing with increasing size of larvae (fig. 2.4a - c). Exceptions occur in #4b (30 min) in which a higher proportion of medium than small larvae did not feed; #6 and #14b (30 min), #8a and #13b (60 min) and #1a, #10a, and #12a (90 min) all in which a higher proportion of large than medium larvae did not feed; and in #7 (30 min) and #11b (60 min) in which a higher proportion of large parasitized larvae than healthy large larvae did not feed. In only two of these cases is the difference between percentages of unfed larvae significant: in #6 (P**) and #1a (P*, after rounding off) the percentage of unfed large larvae is greater than that of unfed medium larvae¹. In most cases, more than 50% of all small larvae did not feed, at least 15% more than any other class. Usually less than 20% of the large parasitized larvae did not feed.

When larvae were exposed to similar velocities and mean [p], but for different feeding periods, the percentage of unfed larvae in each class decreased with time (#4, #8, #10, #11, #12, #13, and #15). When larvae were exposed to similar velocities but different [p] and time, this percentage did not always decrease. In 'doubled' experiments where [p] is not similar, the mean [p] for the shorter feeding period is

¹ Test for equality of two percentages (Sokal and Rohlf 1969).

INGESTION OF PARTICLES BY
SIMULIUM VITTATUM

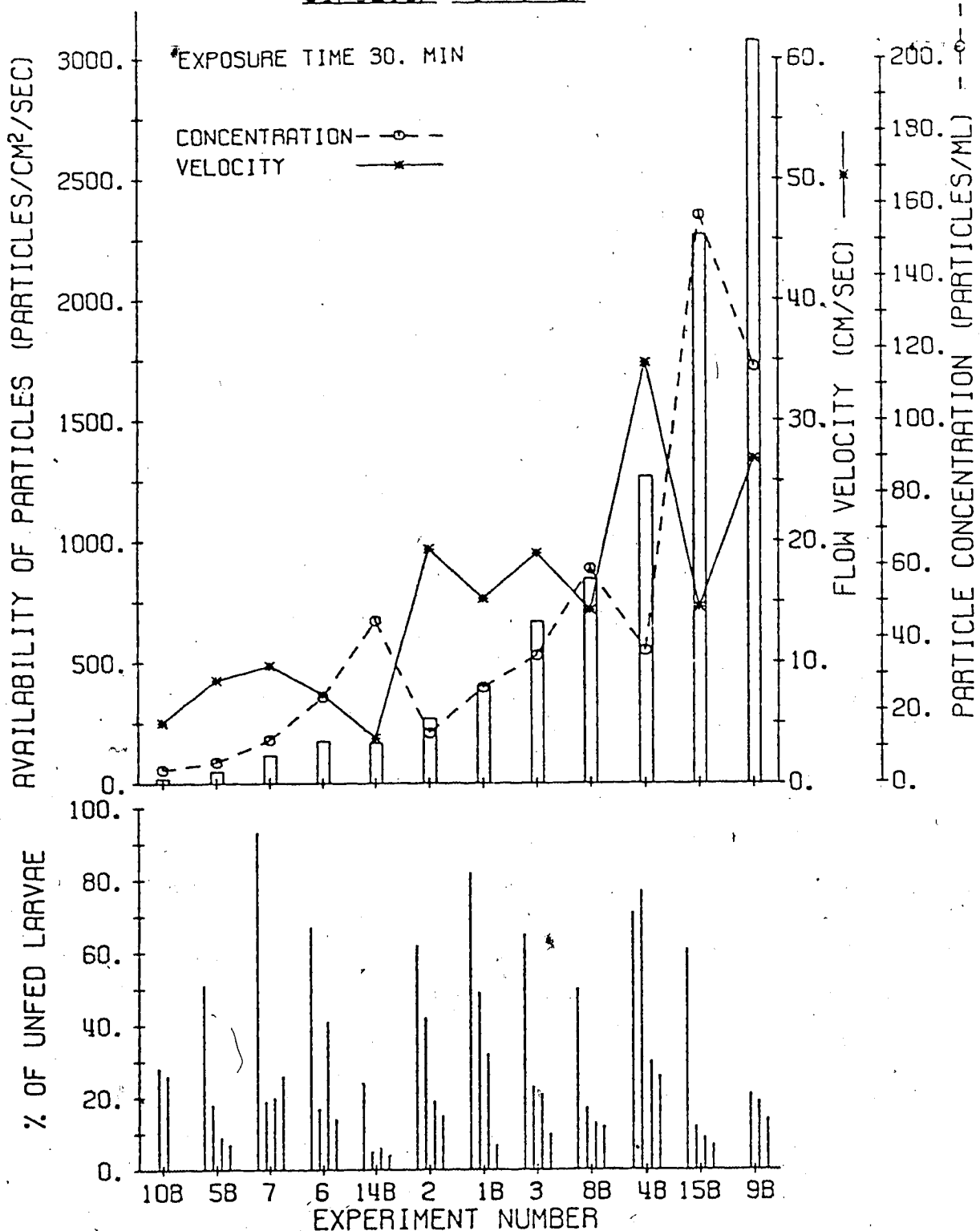

Fig. 2.4a. Percentage of larvae in each of 4 larval classes of Simulium vittatum Zett. which did not feed during exposure to a range of availabilities of particles for 30 minutes. [In figs. 2.4a - 2.4c, the 4 lines of percentage of unfed larvae for each experiment represent, from left to right, small, medium, large, and large parasitized larvae, respectively. In some of the experiments small and large parasitized larvae are not included (see text)].

INGESTION OF PARTICLES BY SIMULIUM VITTATUM ZETT.

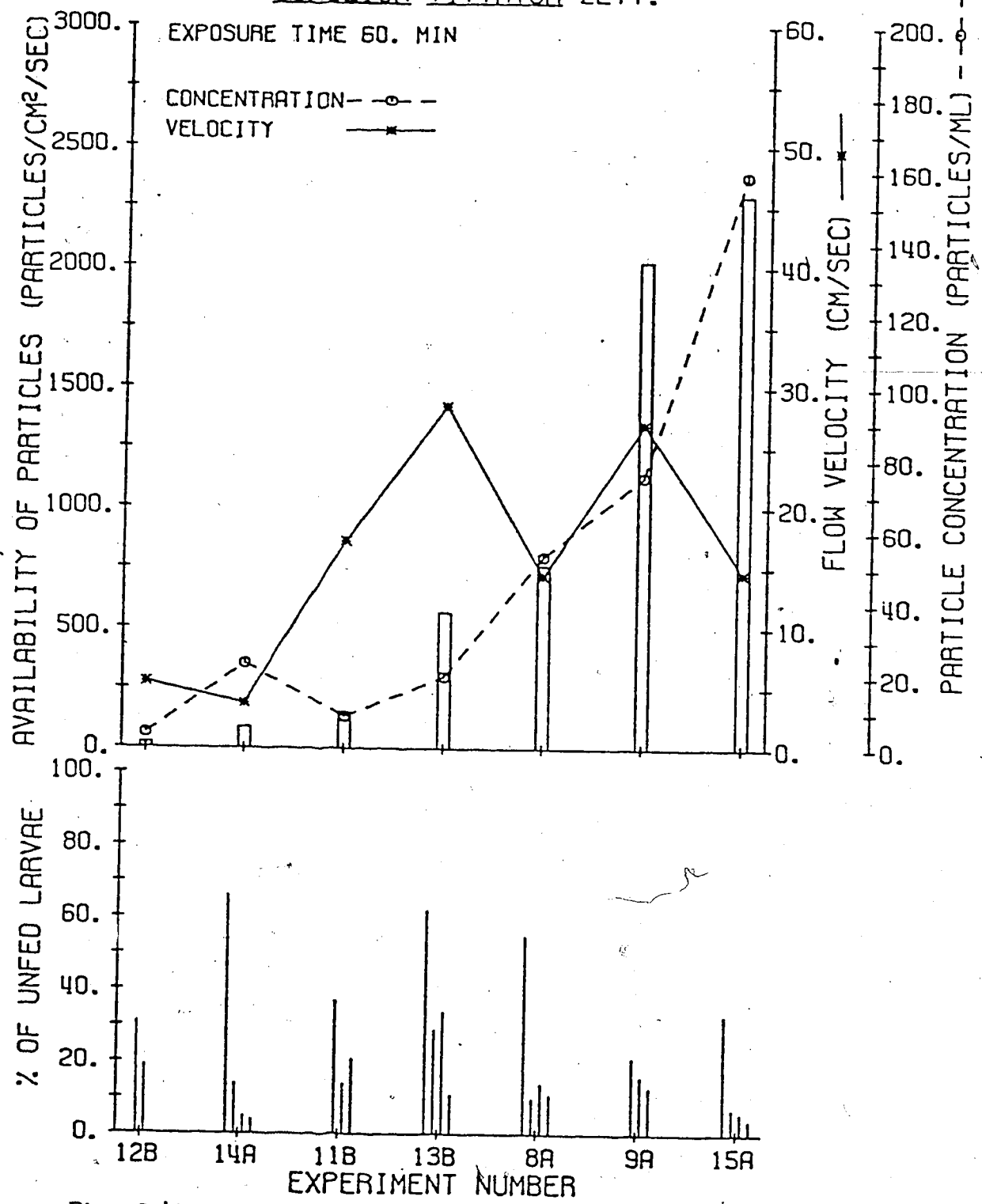

Fig. 2.4b. Percentage of larvae in each of 4 larval classes of Simulium vittatum Zett. which did not feed during exposure to a range of availabilities of particles for 60 minutes.

INGESTION OF PARTICLES BY
SIMULIUM VITTATUM ZETT.

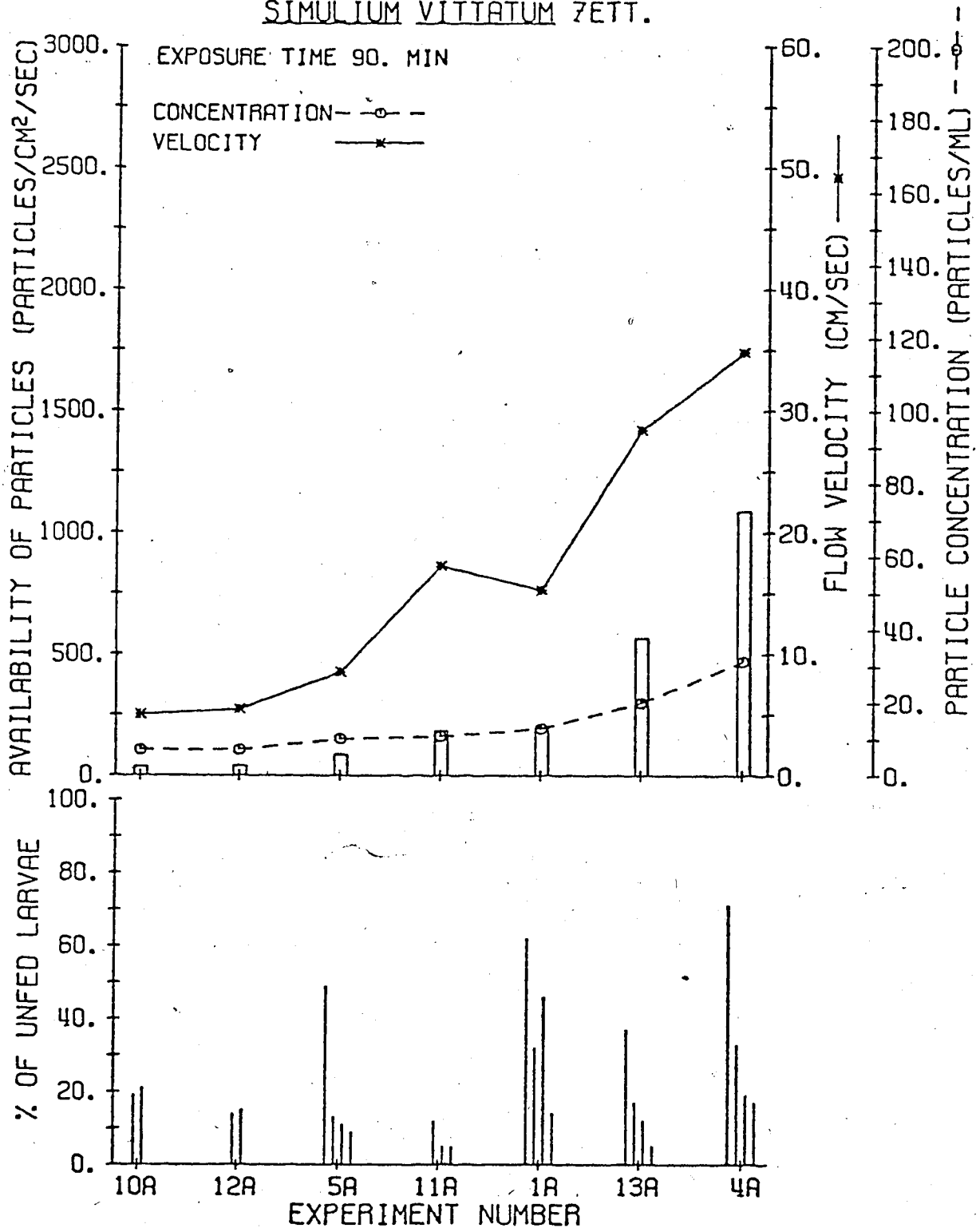

Fig. 2.4c. Percentage of larvae in each of 4 larval classes of Simulium vittatum Zett. which did not feed during exposure to a range of availabilities of particles for 90 minutes.

INGESTION OF PARTICLES BY
SIMULIUM VITTATUM ZETT.

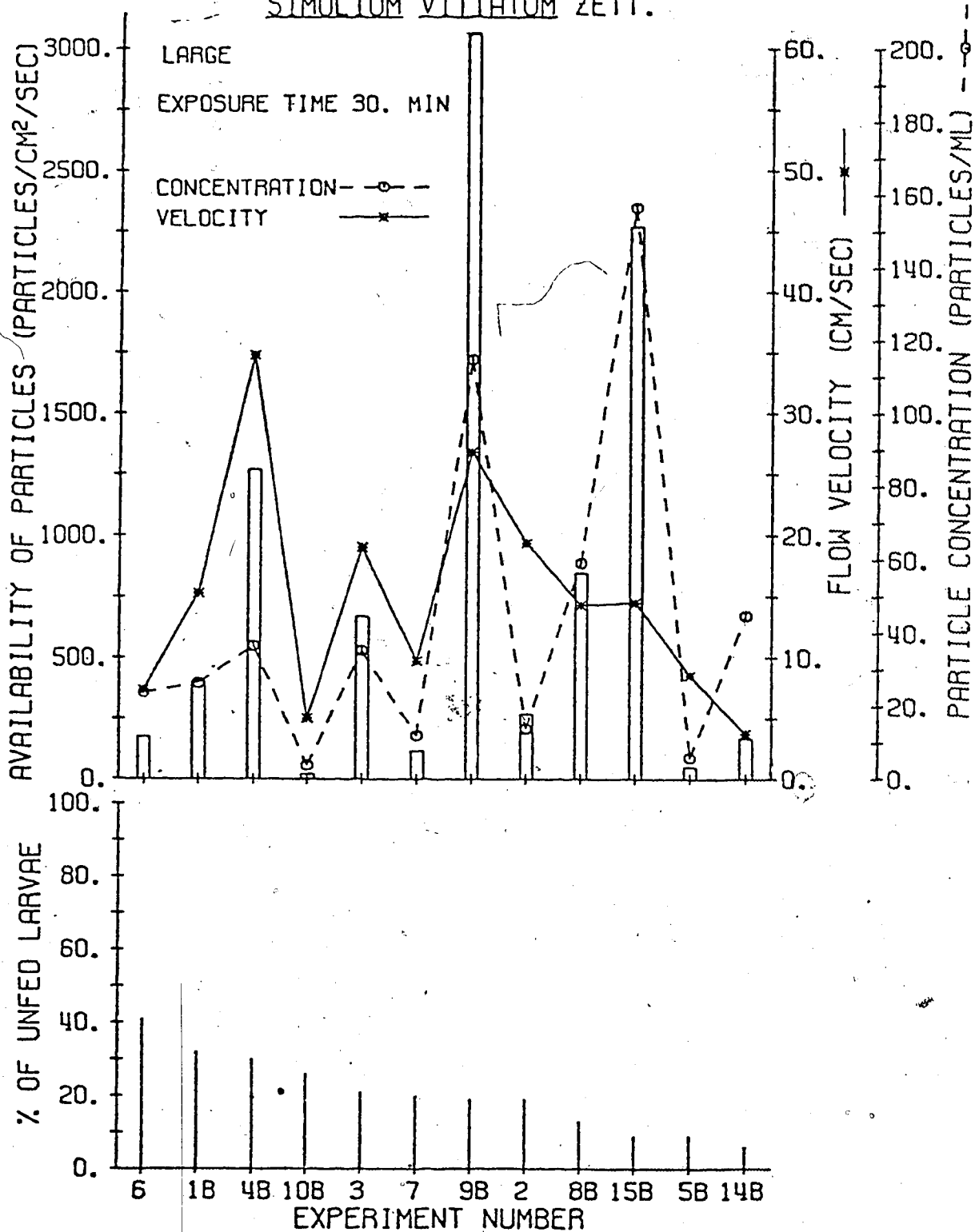

Fig. 2.4d. Percentage of large larvae of Simulium vittatum Zett. which did not feed during exposure to a range of availabilities of particles for 30 minutes.

INGESTION OF PARTICLES BY
SIMULIUM VITTATUM ZETT.

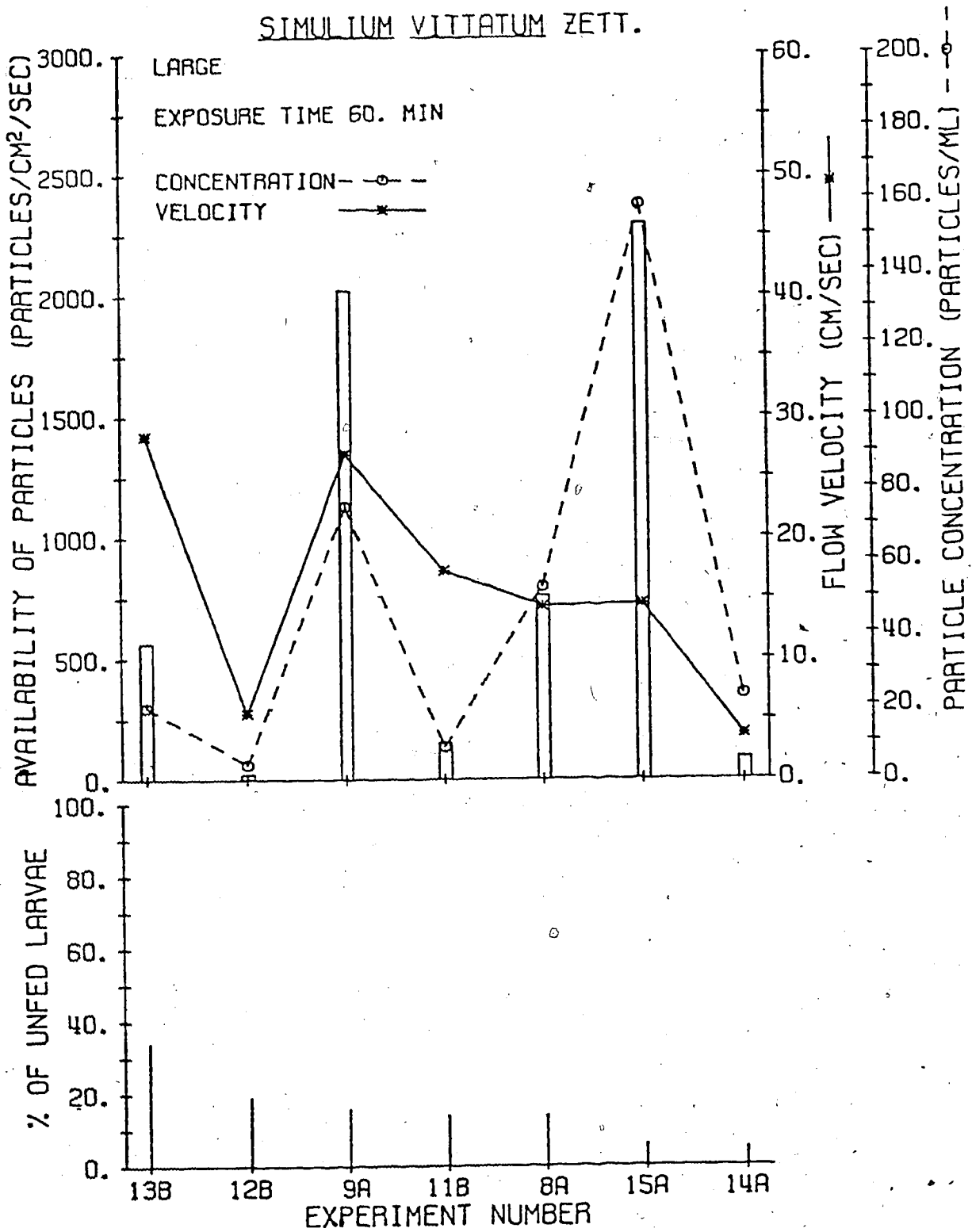

Fig. 2.4e. Percentage of large larvae of Simulium vittatum Zett. which did not feed during exposure to a range of availabilities of particles for 60 minutes.

INGESTION OF PARTICLES BY
SIMULIUM VITTATUM ZETT.

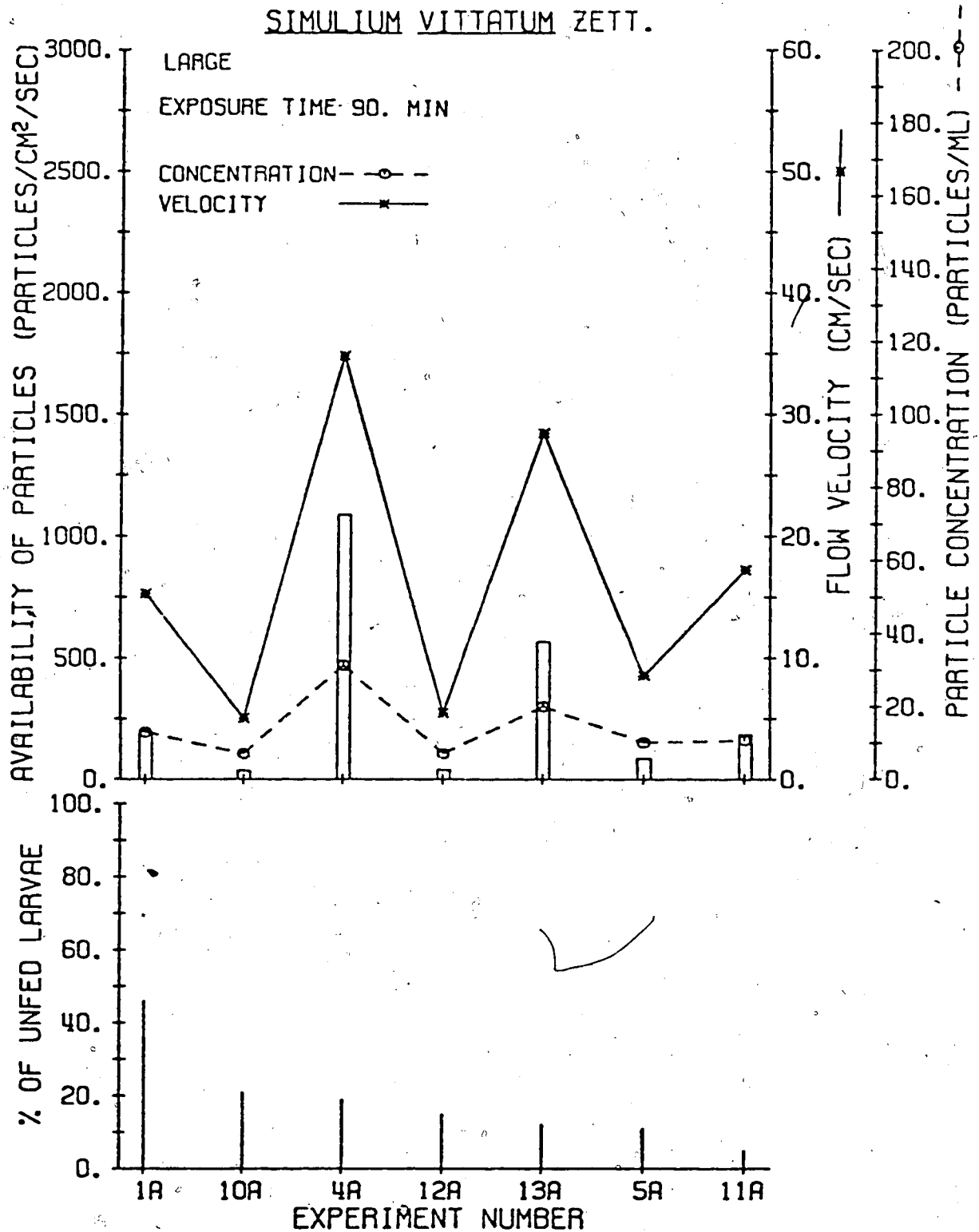

Fig. 2.4f. Percentage of large larvae of Simulium vittatum Zett. which did not feed during exposure to a range of availabilities of particles for 90 minutes.

INGESTION OF PARTICLES BY
SIMULIUM VITTATUM ZETT.

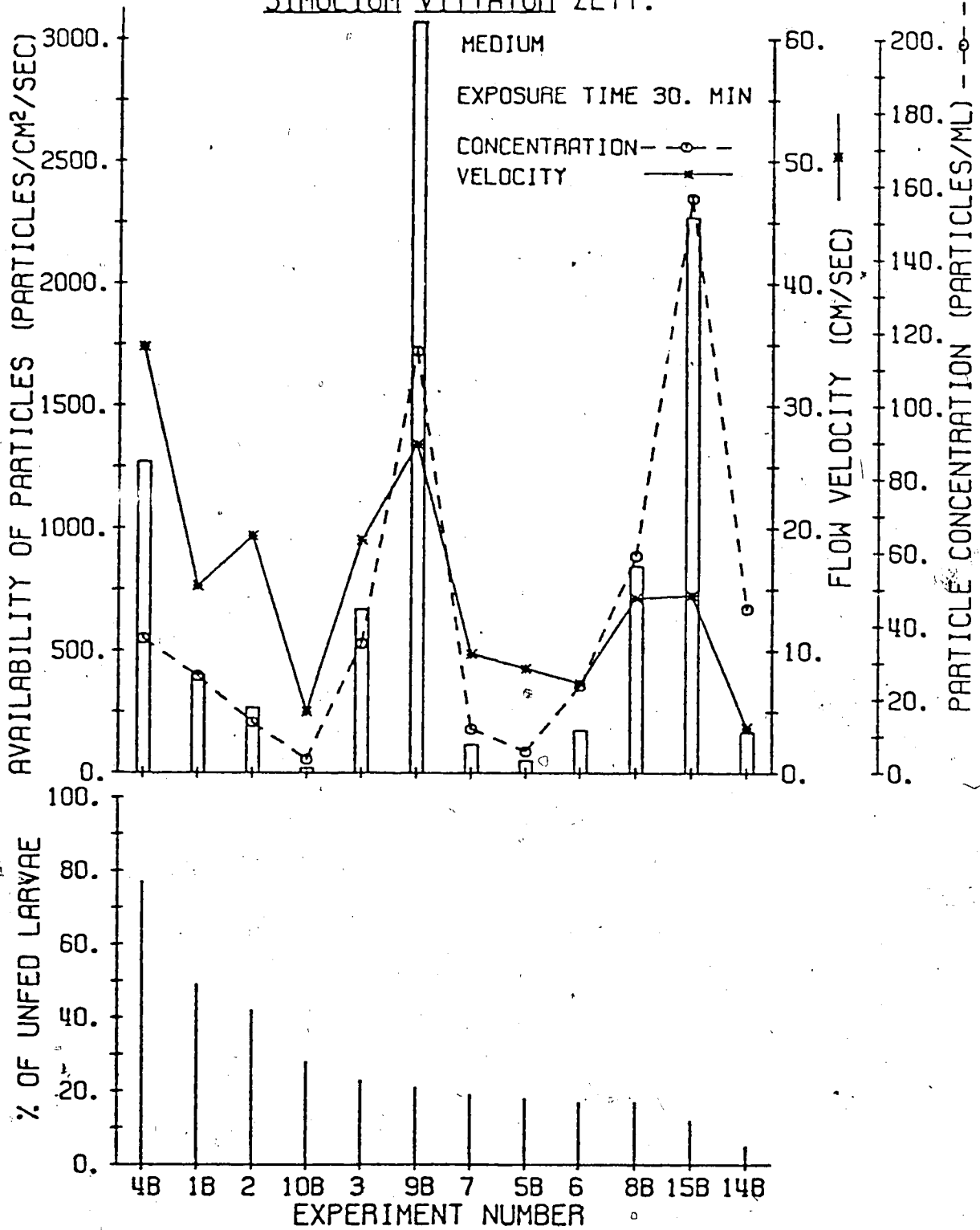

Fig. 25. Percentage of medium larvae of Simulium vittatum Zett. that did not feed during exposure to a range of availabilities of particles for 30 minutes.

INGESTION OF PARTICLES BY
SIMULIUM VITTATUM ZETT.

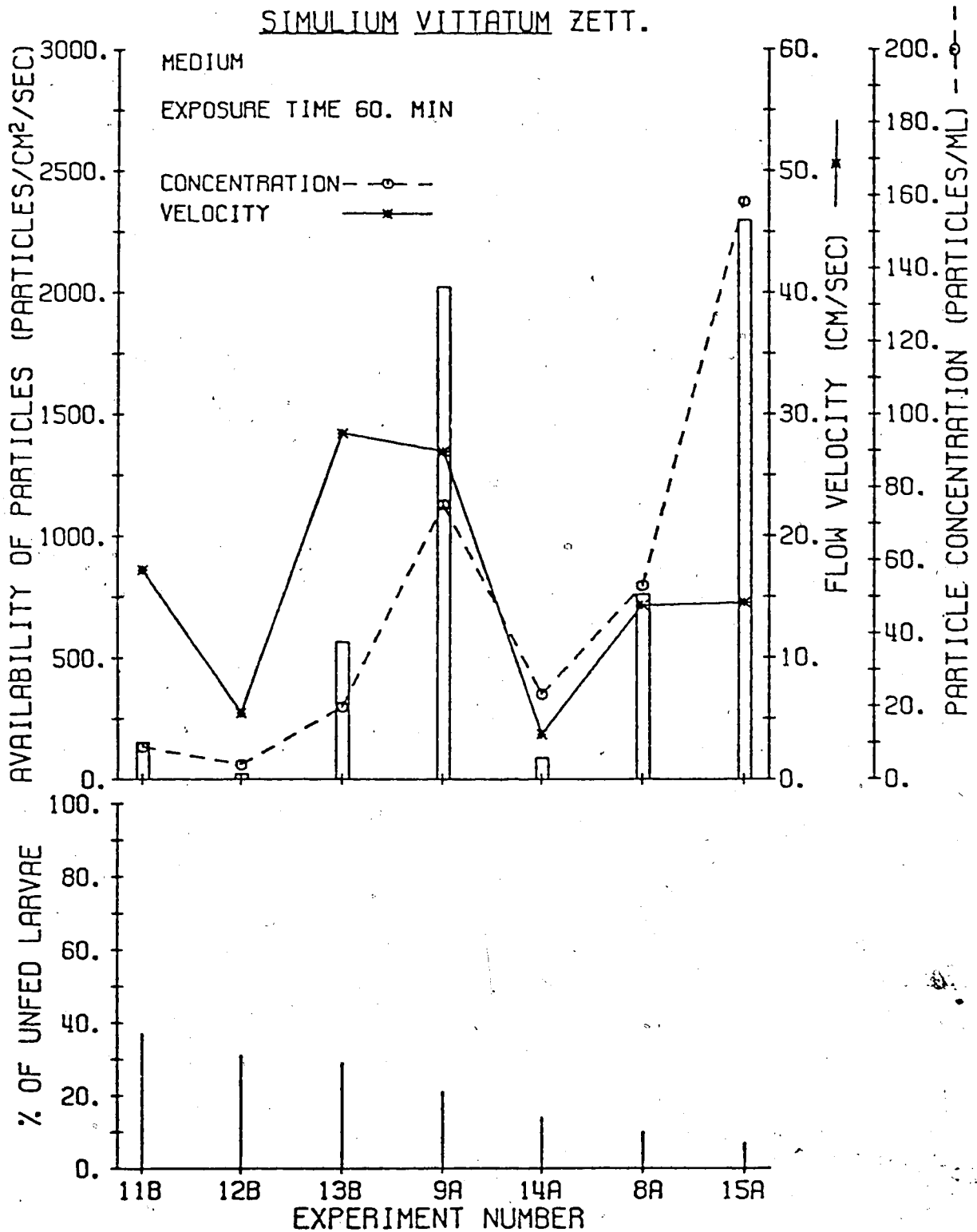

Fig. 2.4h. Percentage of medium larvae of Simulium vittatum Zett. which did not feed during exposure to a range of availabilities of particles for 60 minutes.

INGESTION OF PARTICLES BY
SIMULIUM VITTATUM ZETT.

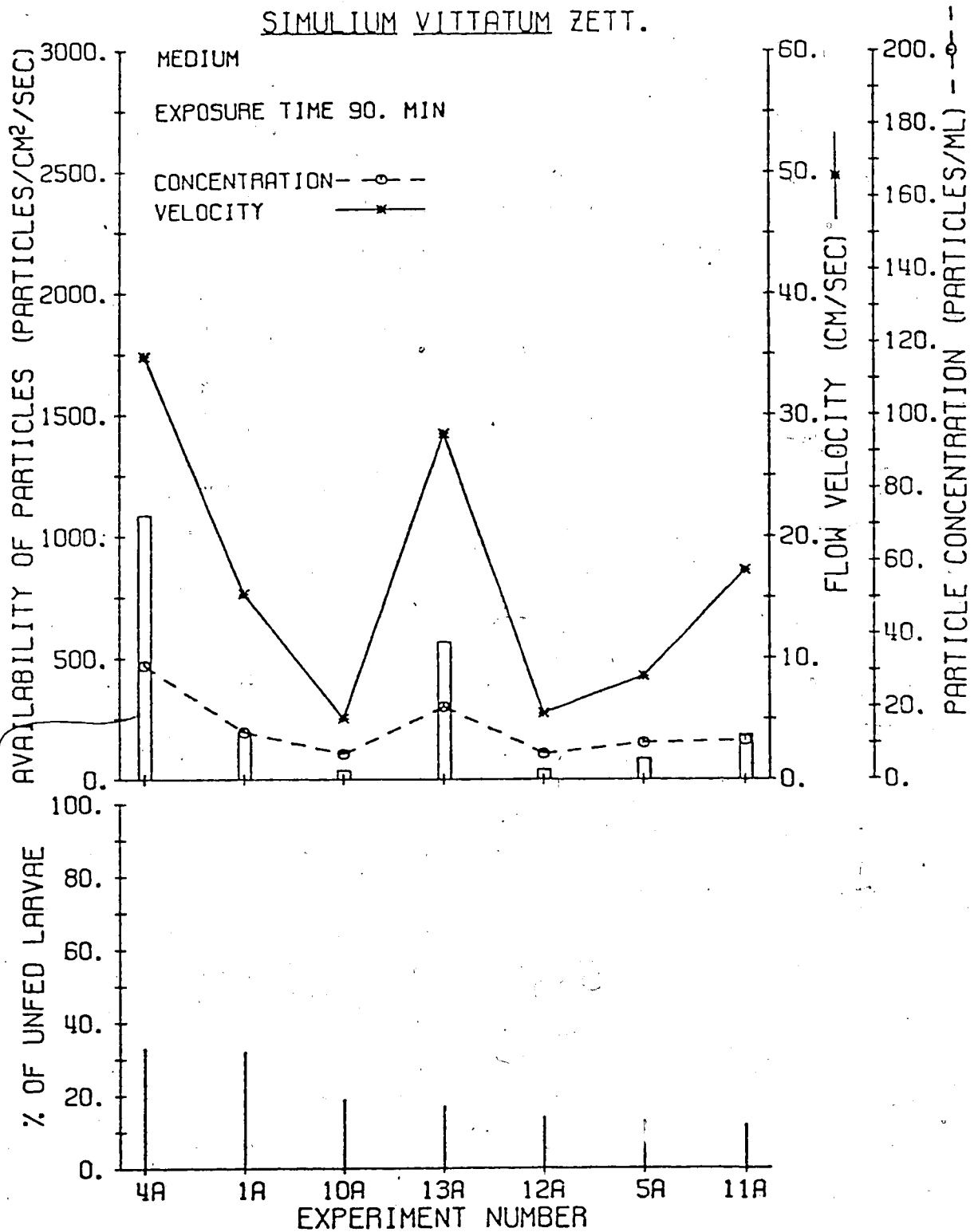

Fig. 2.41. Percentage of medium larvae of Simulium vittatum Zett. which did not feed during exposure to a range of availabilities of particles for 90 minutes.

INGESTION OF PARTICLES BY
SIMULIUM VITTATUM ZETT.

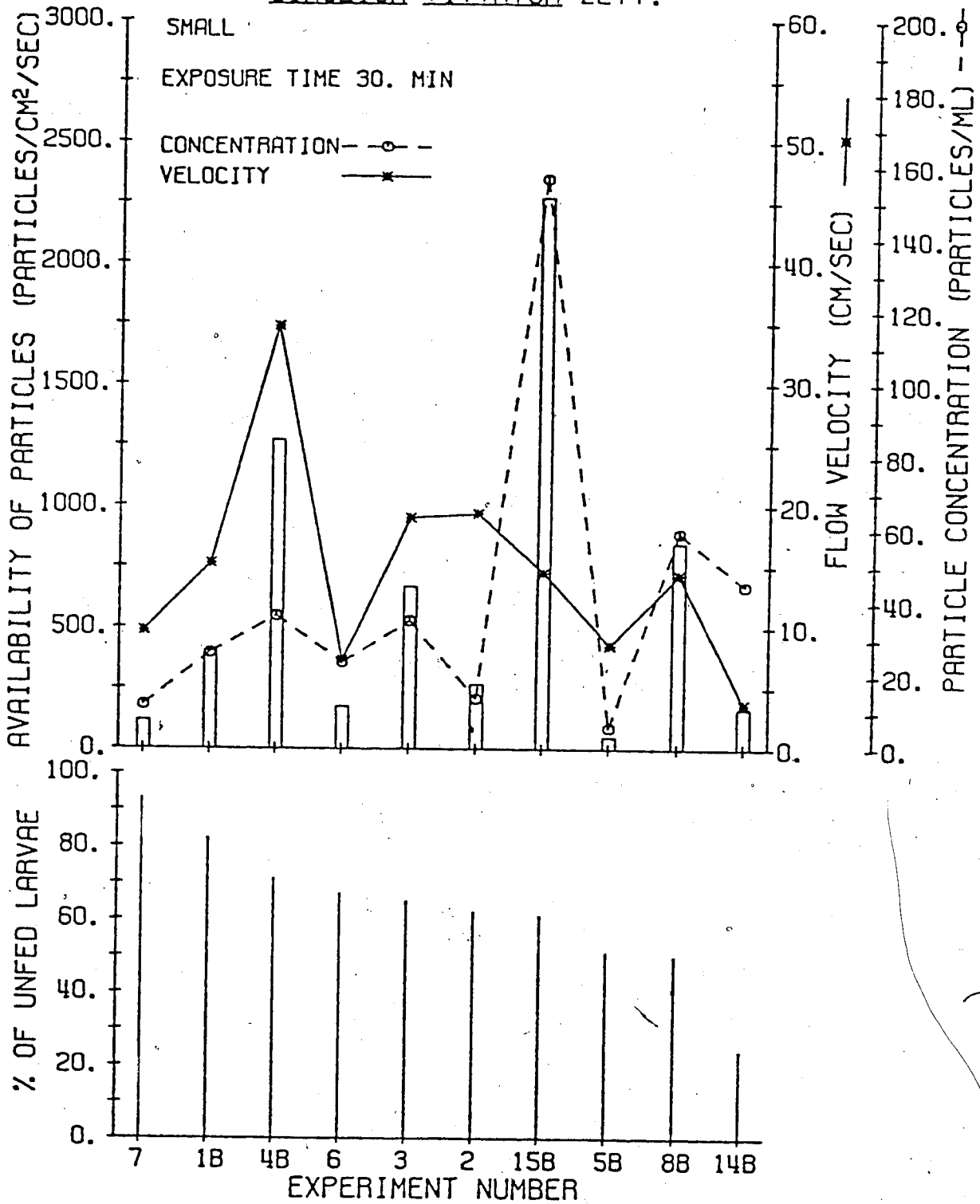

Fig. 2.4j. Percentage of small larvae of Simulium vittatum Zett. which did not feed during exposure to a range of availabilities of particles for 30 minutes.

INGESTION OF PARTICLES BY
SIMULIUM VITTATUM ZETT.

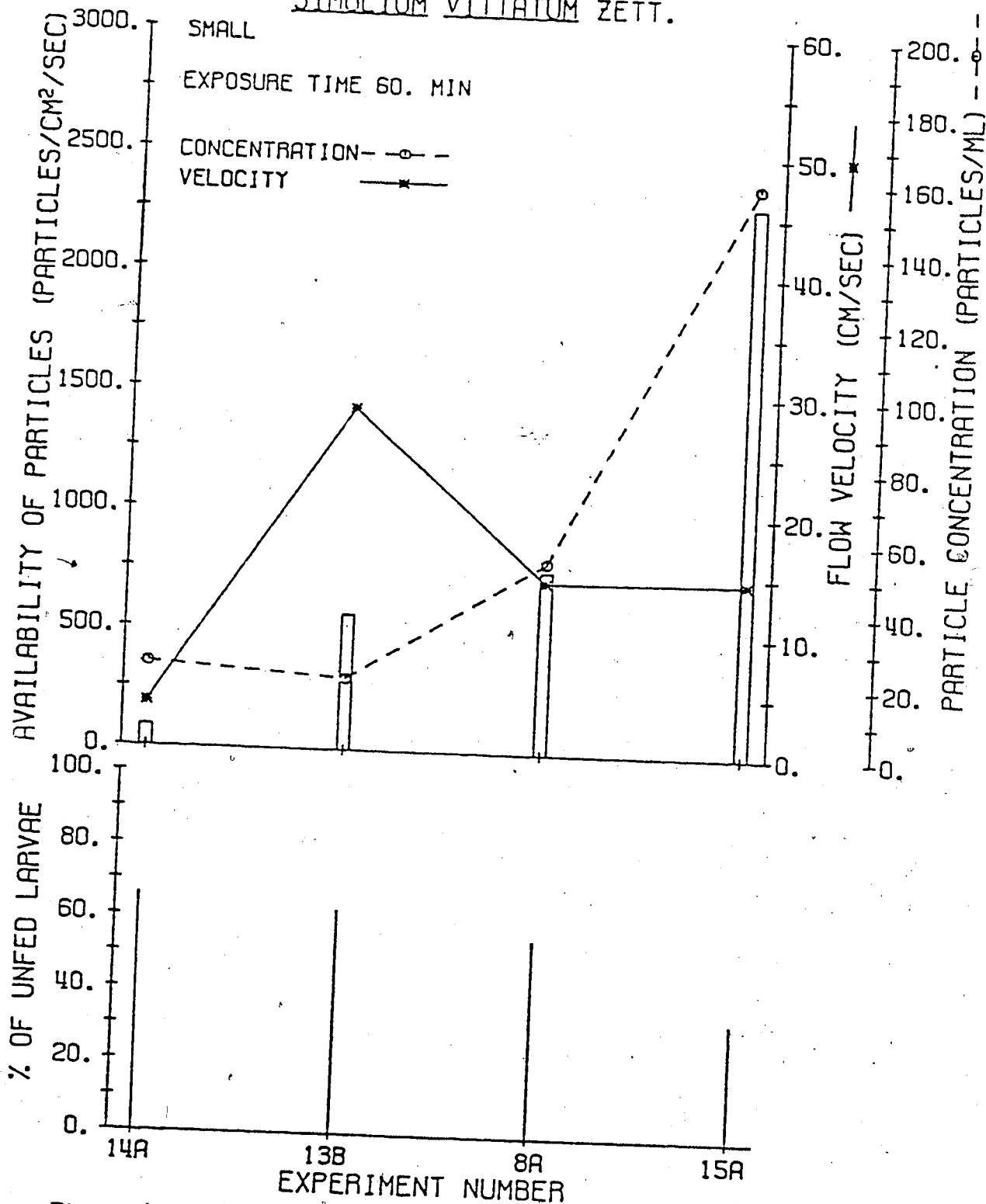

Fig. 2.4k. Percentage of small larvae of Simulium vittatum Zett. which did not feed during exposure to a range of availabilities of particles for 60 minutes.

INGESTION OF PARTICLES BY
SIMULIUM VITTATUM ZETT.

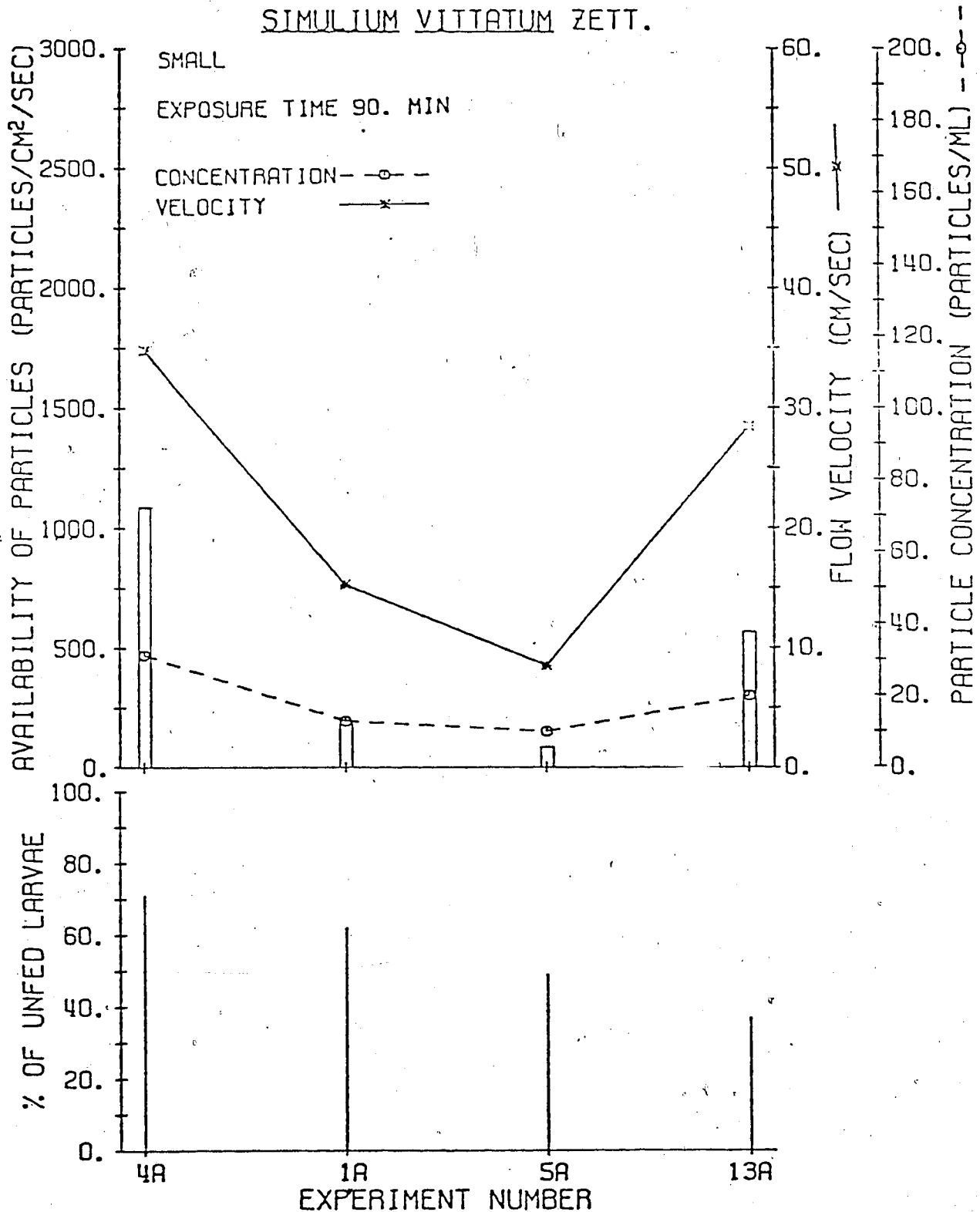

Fig. 2.41. Percentage of small larvae of Simulium vittatum Zett. which did not feed during exposure to a range of availabilities of particles for 90 minutes.

INGESTION OF PARTICLES BY
SIMULIUM VITTATUM ZETT.

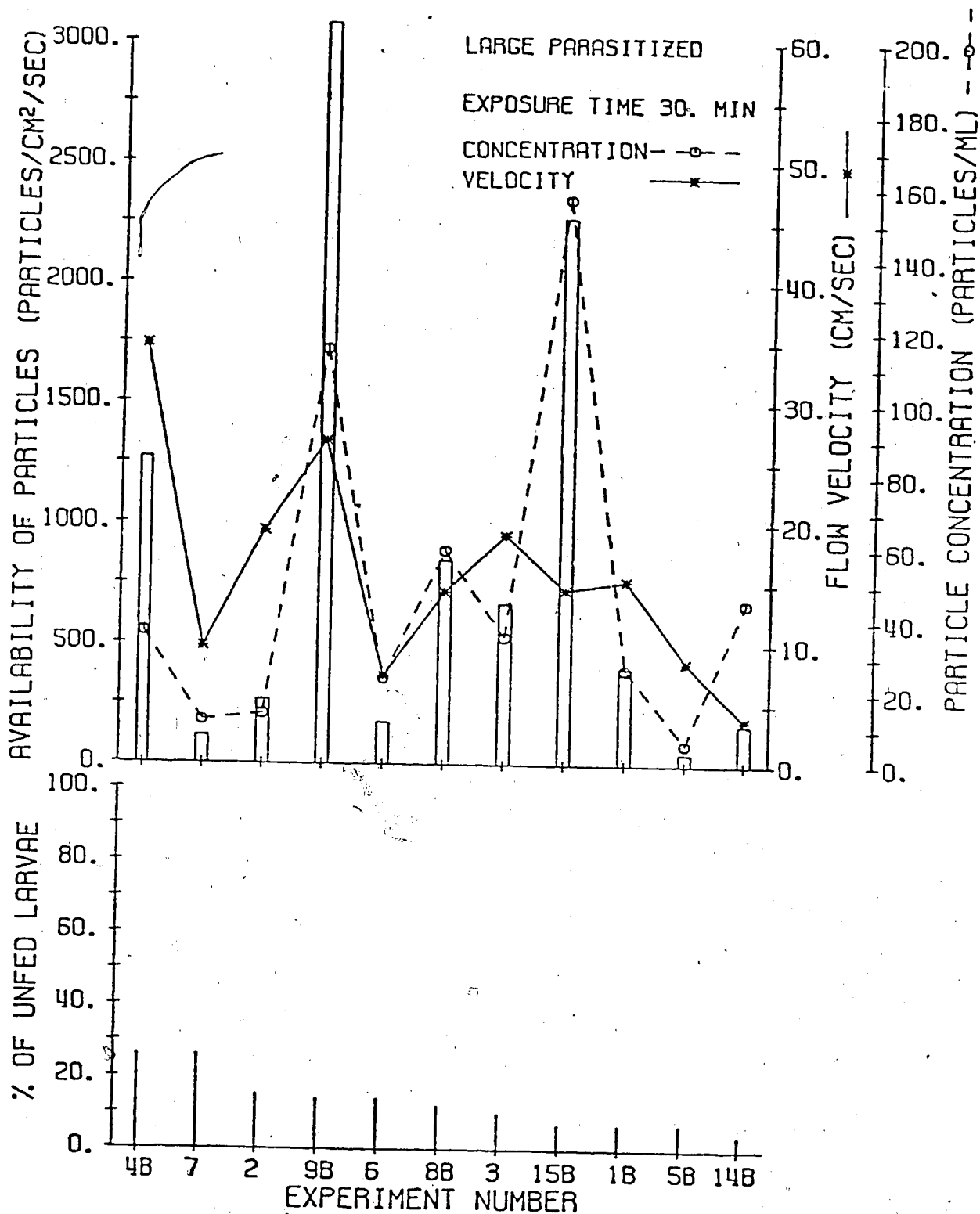

Fig. 2.4m. Percentage of large parasitized larvae of Simulium vittatum Zett. which did not feed during exposure to a range of availabilities of particles for 30 minutes.

INGESTION OF PARTICLES BY
SIMULIUM VITTATUM ZETT.

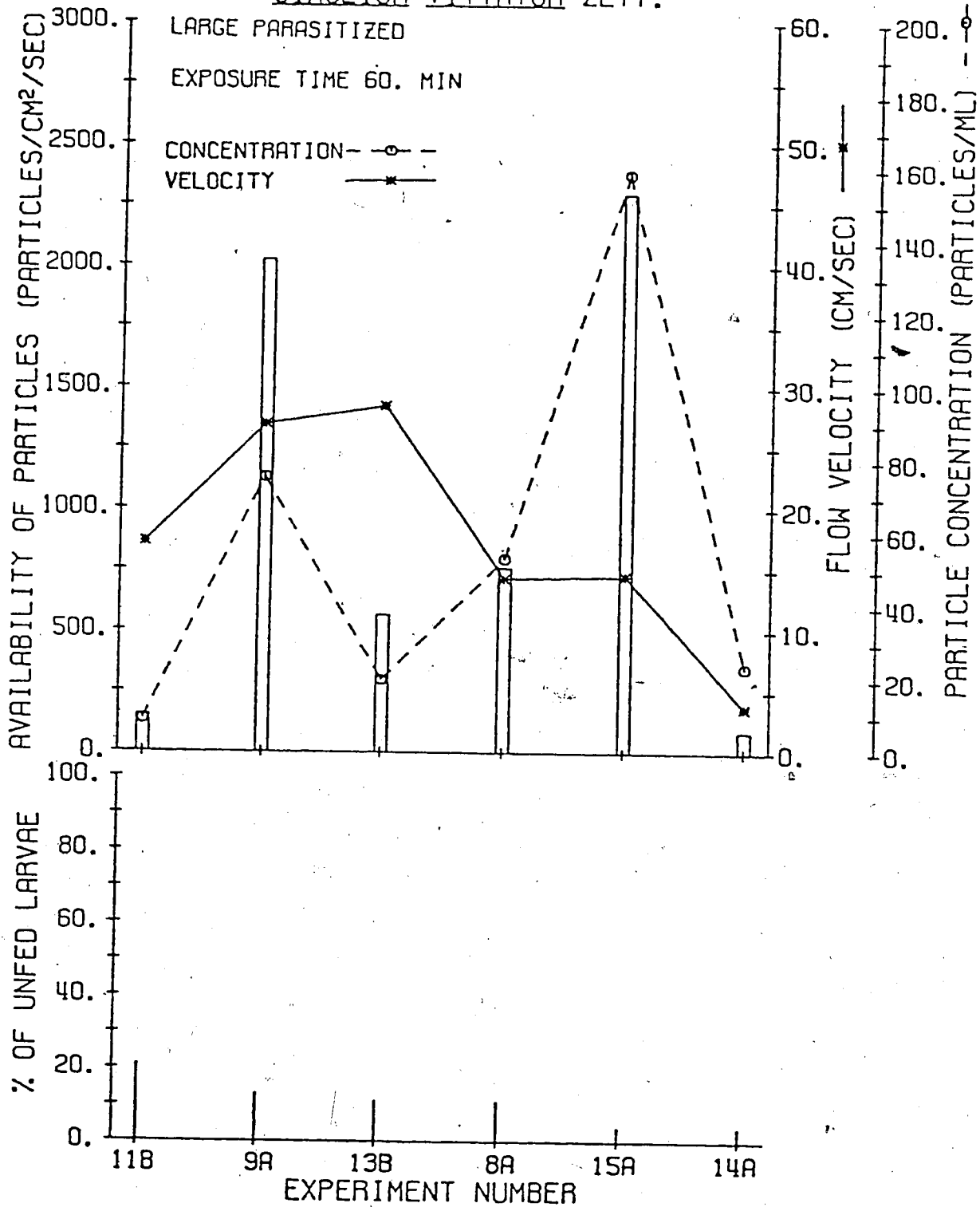

Fig. 2.4n. Percentage of large parasitized larvae of Simulium vittatum Zett. which did not feed during exposure to a range of availabilities of particles for 60 minutes.

INGESTION OF PARTICLES BY
SIMULIUM VITTATUM ZETT.

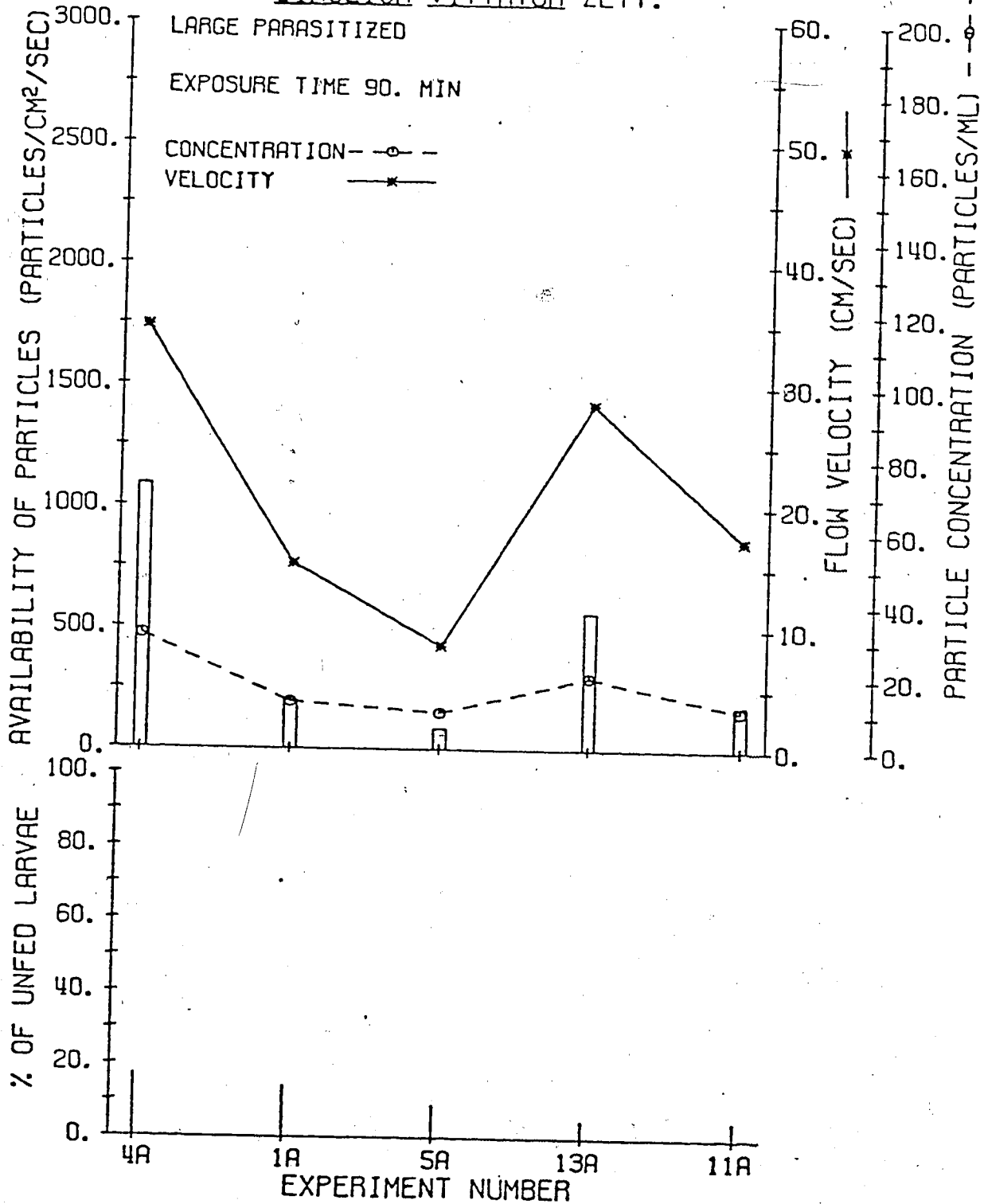

Fig. 2.40. Percentage of large parasitized larvae of Simulium vittatum Zett. which did not feed during exposure to a range of availabilities of particles for 90 minutes.

approximately twice that for the longer period, e.g. #1, #5, and #14. Under moderate or slow velocities a higher proportion of larvae in all classes fed during the shorter period (table 2.6; #1, #10, and #14). Exceptions occur in #9 in which velocity and mean [p] were high, and ingestion was low (sect. 2.3.3.2.). In experiment #1 a smaller proportion of large larvae fed during the longer feeding period; in #14 a smaller proportion of medium and small larvae fed during the longer feeding period.

Although the percentage of unfed larvae varies with class and tends to increase with decreasing size of larvae within each experiment, conditions of the experiments tend to influence similarly feeding among larval classes. Among the 30-minute experiments, the lowest percentage of unfed larvae in all classes occurred in experiment #14b (fig. 2.4d, g, j, m). In experiments #1b, #4b, and #5b a high percentage of unfed larvae occurred in all classes. In the 60- and 90-minute experiments, most larvae fed during #14a, #15a, #5a, #11a, and #12a for all classes, except small larvae in #14a (figs. 2.4e, f, h, i, and k, l, n, o). In experiments #12b, #13b, #11b, and #9a (60 minutes) and #1a, #10a, and #4a (90 minutes) a smaller proportion of larvae in all classes fed.

After 30 and 60 minutes, fewer larvae tended to feed under high velocities. However, when velocity is high, more larvae tend to feed when mean [p] is high, e.g. #9b, #15a, #15b. In some experiments larval feeding does not conform to this trend, especially among small and large parasitized larvae (#1b, #3, #4b) and some large larvae (#12b, #10b, #7).

Table 2.6. Percentage of unfed larvae in each of 4 larval classes of *Simulium vittatum* within 'doubled' experiments.

Expt.	Time (min)	Larval Class			
		Small (n)	Medium (n)	Large (n)	Large P. (n)
1a	90	61.80 (322) [†]	31.71 (410)	46.03 [†] (63)	13.97 [†] (229)
1b	30	81.99	48.53	31.74	7.42
4a	90	71.21 (66)	33.33 (327)	19.15 (47)	16.98 (53)
4b	30	71.21	77.37	30.18	26.41
5a	90	49.49 (99)	12.96 (378)	10.81 [†] (37)	8.89 [†] (45)
5b	30	50.01	17.94	8.82	6.67
8a	60	55.00 (40)	9.90 (394)	13.51 (84)	11.36 (44)
8b	30	50.00	17.30	13.09	11.63
9a	60		21.25 (369)	16.25 (80)	12.82 (37)
9b	30		21.35	18.51	13.25
10a	90		19.23 (442)	21.21 (66)	
10b	30		28.05	25.75	
11a	90		12.33 (438)	4.82 (83)	5.00 (20)
11b	60		36.73	14.12	21.05
12a	90		13.97 (417)	15.48 (84)	
12b	60		31.49	19.28	
13a	90	36.84 (114)	16.95 (301)	12.31 (65)	5.40 (37)
13b	60	62.28	29.37	33.84	10.81
14a	60	65.79 [†] (76)	13.91 [†] (344)	4.76 (96)	4.35 (23)
14b	30	23.68	5.08	5.99	4.35
15a	60	33.33 (69)	6.90 (290)	6.25 (96)	3.51 (57)
15b	30	61.32	12.41	9.47	7.02

n = total number of larvae in each class.

[†] denotes experiments in which a significantly ($P = 0.05$ or less) higher proportion of larvae fed during the shorter time period.

2.4. DISCUSSION

2.4.1. Parasitism

The increase in percentage parasitism from medium to large larvae and the absence of small parasitized larvae is probably due to two factors: mode of infection, and increase in exposure time to parasites. Furthermore, parasites are more difficult to detect in small larvae than in larger larvae.

Mode of infection of microsporidian parasites is probably ingestion. Strickland (1911) suggested that microsporidian infection must occur early in larval development, before the peritrophic membrane lines the mesenteron. However, Maurand (1975) states that oral transmission is not sufficient to explain the pattern of infection, and considers inheritance an important factor in infection by microsporidians.

Infective stage mermithid juveniles may enter the host either by being ingested or by penetrating the host's body wall. Strickland (1911), the first to describe mermithid parasitism of black flies in North America, suggested that oral infection was the probable mode of infection, but mentioned penetration of the host body wall as an alternative route. It has been generally accepted that infection among black flies is by ingestion of infective stage parasitic juveniles (Welch 1964, Welch and Poinar 1964, Chapman 1973, Dumbleton 1972). Strong evidence supporting this is provided by laboratory experiments in which *Simulium vittatum* larvae were exposed to infective

stage nematodes, including mermithids. Parasites were found first in the guts of the host larvae and later in the host's haemocoel, where they develop (Phelps and DeFoliart 1964, Webster 1973). Published reports of field observations of parasitism in natural populations do not mention parasites in small larvae. However, Molloy and Jamnback (1975) showed experimentally that *Neomesomermis fluminalis* (Welch) can infect *S. vittatum* by penetrating the body wall, and Bailey¹ (pers. comm.) has shown that all larval instars of *S. venustum* can be infected experimentally by *N. fluminalis* juveniles penetrating the host body wall. Field collections of *Prosimulium hirtipes* larvae have included parasitized first and second instars. Other studies suggest that infection is by penetration of the body wall (Bailey and Gordon 1977). Detection of mermithid parasitism of early instars is exceedingly difficult unless both host and parasite are alive. Mermithids are known to infect chironomid and mosquito larvae by penetrating the host body wall (Molloy and Jamnback 1975, Bailey and Gordon 1977).

Since black fly larvae are unselective feeders, it is possible that both methods of host infection occur. The period during which a larva can be infected extends over most of its larval stage. Juvenile nematode parasites were found in medium and large host larvae (Appendix E). In cases of multiple parasitism, nematodes are usually of different stages of development.

The proportion of parasitized larvae varies with experiments, with earlier experiments having less. Although all parasitized larvae

¹ Dr. P. Bailey, Department of Biology, Memorial University.

grouped into one class, it is realized that the different types, numbers, and stages of parasites will have different effects on the hosts.

2.4.2. Experimental design

Differences in ingestion by larvae under various conditions were tested using analysis of variance. Because percentages of gut filled during the experimental time period varied so much among larvae within each larval class, a mean percentage of gut filled is not a good estimate of ingestion. Means of percentage gut filled which include un-fed larvae would provide even less reliable estimates of ingestion since the proportion of larvae which did not feed varied greatly. In some cases it was as high as 80% of the larvae. Thus the use of means as a basis for comparison might lead to misleading interpretation of the experimental results. Further, it appears that feeding and extent of feeding, as opposed to non feeding, are two separate phenomena.

High variation in ingestion by larvae has been reported for larvae of several species (Davies and Syme 1958, Fredeen 1964, Chance 1969, Ladle et al 1972). It may be typical of the opportunistic nature of passive filter-feeding. Lack of feeding by some larvae for different periods is responsible for part of this variation.

The design of the experiments requires that particles be equally available to all larvae, at least within each class. If this requirement is not met, variation in either percentage gut filled or percentage of

unfed larvae will be partially due to variations in availability of particles rather than to behavioural variations of the larvae. Because flow in the flume is not laminar and because it is unlikely that particle distribution throughout the flume was uniform, availability of particles was probably not equal for all larvae in each class. However, the assumption that availability was equal is still reasonable. Flow in the flume was regular and mixing of particles in the water was rapid. Particles appeared at the exit of the test channel within 60 seconds after being added. Flow down the flume was examined by adding coloured fluids and suspensions at the entrance of the test channel; these moved steadily and smoothly downstream, moving more slowly close to the sides and bottom of the channel than in the mainstream. Differences in availability of particles to the larvae are therefore assumed to be small.

Ingestion by larvae in all classes during experiments #1a, b (fig. 2.3a, c) was less than expected, in comparison to the results of the other experiments. In addition, the mean percentage gut filled differed significantly between larval classes. This doubled. experiment differed from the others in being conducted late in the day (under artificial room lighting) when larvae may have been engaged in more non-feeding activities, and with 2-6 times the total number of larvae in the other experiments. Sommerman et al (1955) and Fredeen (1964) observed that the rate of development of larvae is reduced under crowded conditions. However, a density of 3000 larvae over the area of the flume is less than 2 larvae/cm², not a crowded population

compared to populations frequently occurring in the field. The presence of other larvae influences the availability of particles to a particular larva (sect. 2.3.1.). The presence of larvae in the water flow causes turbulence downstream from the larvae (sect. 1.4.2.). This increases mixing and therefore availability of particles to the larvae. With more larvae present, the availability of particles at the level of the larvae may be underestimated. Since larvae of *S. vittatum* ingest more rapidly under lower availabilities, this might explain the low level of ingestion.

The rate of reduction of [p] in #1a, b is greater than that occurring in other experiments. This is probably due to the larger number of larvae present, and to the greater amount of salivary silk produced. There was also a higher proportion of large parasitized larvae present, about 10 times that in other experiments. Because the rate of reduction of [p] is greater, the estimate of mean [p] available to the larvae is less satisfactory. Larvae exposed to an initially high [p] feed at first at a low level of efficiency, and might not take full advantage of the lower levels of [p] when they occurred.

2.4.3. Experimental conditions

The velocities to which larvae of *Simulium vittatum* were exposed in these experiments are slower than those reported in the literature (table 2.7). Discrepancies among reported measurements are due to difficulties in measuring velocities over a small area accurately (sect. 1.1.2.), differences in techniques used to record water flow,

Table 2.7. Records of water velocities in which larvae of *Simulium vittatum* have been found

Other spp. present	Velocity (cm/sec)	Flowmeter	Reference
	6 - 16	pitot tube	Anderson and Dicke 1960
	30 - 61		"
	45 - 152		"
	3 - 35 (lab.)	hot film	Text, sec. 2.3.1.
	40 (lab.)		Fredeen 1964
	3 - 152		Fredeen and Shemanchuck 1960
	60	pitot tube	Kurtak 1973
	20 - 40 (lab.)	transducer	Kurtak 1973
	5 - 35 (field expt)	-	Williams and Hynes 1976
<i>S. arcticum</i>	25 - 313	pitot tube	Peterson 1956
	10 - 30		Wolfe and Peterson 1960
<i>S. venustum</i>	17 (lab.)	pitot tube	Wu 1931
	36 - 113 "	"	Wu 1931
	25 - 55 "	"	Wu 1931
	52 - 132 "	"	Wu 1931
	17 - 84 "	"	Wu 1931
	183 "	"	Wu 1931

and the wide range of stream conditions in which *S. vittatum* normally occurs. Measurements recorded here were taken at the level of the larval heads, which ranged from 1.5 - 4.0 mm above the substratum, depending on the rate of flow. The range of velocity in which larvae of *S. vittatum* fed was from 3.7 - 35 cm/sec, as measured with a hot film flowmeter. These velocities differ from those determined by Kurtak (1973) for populations of *S. vittatum* in New York. Using a transducer system, Kurtak measured point velocities around larvae of several species of black flies. He measured a range of 20 - 40 cm/sec for feeding velocities for *S. vittatum* larvae. However, he conducted feeding experiments at velocities of 30, 50, and 70 cm/sec, and records a field velocity of 60 cm/sec (measured with a pitot tube) for *S. vittatum* populations. In 7 of the 10 species he studied, Kurtak records faster habitat velocities than experimental maximum feeding velocities.

Estimates of particle concentration are averages over depth of water in the flume and duration of experiment. Mixing of particles is more rapid in faster velocities, thus higher mean [p] occurred in faster velocities. It is assumed that the particles are more or less uniformly distributed in the water and therefore the water samples collected at the exit of the flume provide a reliable estimate of the concentration of particles to which the larvae were exposed (at times of collection of the water samples).

Attempts to measure [p] in water filtered by the larvae failed. Water samples were collected, by suction using a vacuum, at 9 stations

along the length and width of the flume at the level of the larval heads. Particles caught in the salivary secretion produced by larvae were differentially sucked into the water sample, and introduced a high degree of error in the estimates of particle concentration. Kurtak (1973) also found that suction for collecting samples of particle concentrations was unsatisfactory.

Because of the reduction in $[p]$ with time and because estimates of $[p]$ are mean values based on regression analyses, estimates of $[p]$ for shorter experiments are more representative of $[p]$'s to which the larvae were exposed than estimates for longer experiments.

The reduction in range of availability of particles for 60 and 90 minutes may account in part for the lack of difference in ingestion by small larvae between experiments. Furthermore, not only are medium and small larvae exposed to fewer particles suitable for their ingestion than are large larvae, they may also spend more time manipulating the larger particles caught in their fans. This may be a factor contributing to the lower percentage of small larvae which fed during the experiments.

2.4.4. Ingestion

2.4.4.1. Ingestion and availability of particles

The following generalizations can be made about ingestion by larvae of *Simulium vittatum* under the conditions of velocity and $[p]$ to which they were exposed:

- i) Relative to size of larvae, ingestion within each experiment is similar for all classes of larvae.

- ii) Above a certain level of availability of particles, ingestion by larvae increases with decreasing availability. Maximum ingestion occurs around an availability of 100 - 200 particles/cm²/sec. This applies whether the decrease in availability is due to a decrease in velocity or [p].
- iii) The proportion of unfed larvae in each larval class increases with decreasing size of larvae.
- iv) The proportion of unfed larvae in each class varies with availability of particles.

In two of the experiments, #1a and #1b, larval feeding did not fit these patterns. These experiments differed from the others in that they were carried out late at night (2300 hrs) and with a greater number of larvae in the flume (table 2.1, and sect. 2.4.2.).

2.4.4.2. Ingestion among larval classes

The lack of difference in percentage gut filled between larval class in any one time period agrees with the earlier reports of Fredeen (1964) on *Simulium venustum* and Ladle (1972) on *S. ornatum* and *S. equinum*, but not with those of Elouard and Elsen (1975) on *S. damnosum* and Mulla and Lacey (1976) on *S. vittatum*, *S. argus*, and *S. tescorum*. The rate at which the gut is filled depends on the availability of particles, size of the cephalic fans and mouthparts, and efficiency of filtering. Availability of particles varies with larval class because larvae filter water at different heights above the substratum (sect. 1.3.1.), and because the frontal area of the cephalic fans varies with the size of larva (table 2.8).

Peterson (1956) measured a frontal area of 1.34 mm^2 for cephalic fans of larvae ($n = 3$) of *S. vittatum*; Kurtak (1973), a frontal area of 1.16 and 1.13 mm^2 for 'later instar' larvae of two populations of *S. vittatum*.

The measurements of these authors are larger than measurements for large larvae in this study, but are still within the range of size of frontal area measured here. Larvae within the 'large' class of this study may include penultimate instars. Further, the size of larvae of the same instar varies seasonally and possibly geographically.

Table 2.8. Mean and relative sizes of cephalic fans and guts of larvae of *Simulium vittatum*

Larval class	Frontal area		Gut dimensions ³ (mm)			Relative ² volume	Feeding ratio ⁴
	both fans ¹ (mm^2)	relative ²	length	width	volume		
Large P.	1.59 ± 0.46	209	5.21 ± 0.77	0.22 ± 0.04	0.198	161	0.77
Large	0.79 ± 0.12^5	100	4.34 ± 0.39	0.19 ± 0.03	0.123	100	1.00
Medium	0.52 ± 0.04^5	68	3.50 ± 0.45	0.12 ± 0.03	0.040	32	0.47
Small	0.18 ± 0.02^5	24	2.17 ± 0.48	0.04 ± 0.02	0.003	2	0.08

¹ $n = 10$.

² based on size of large larvae arbitrarily chosen as 100.

³ $n = 30$.

⁴ Feeding ratio = relative gut volume/relative frontal area of both fans.

⁵ from Chance 1970a.

If the availability of particles is assumed to be similar for all classes, the feeding ratios indicate that small and medium larvae are less efficient than large larvae and parasitized larvae are less efficient than healthy ones (table 2.8). Small larvae were under

a disadvantage in being exposed to some particles too large for them to ingest readily. Because of the indirect method of estimating efficiencies of ingestion, these conclusions are tentative. Kurtak (1973) measured efficiencies of ingestion in larvae of several species of black flies, and found that efficiencies varied according to conditions under which larvae fed, but not according to size of larva when larvae were exposed to the same particle type.

The lack of difference in percentage gut filled among larval classes in these experiments does not agree with the results of Elouard and Elsen (1975) and Mulla and Lacey (1976). Elouard and Elsen measured the rate of movement of synthetic particles and charcoal particles through the guts of *Simulium damnosum* larvae. They determined that the rate of movement increased with age of larva. They demonstrated a linear relationship between larval instar and rate of movement of gut contents. However, the slope of the regression line of movement of gut contents against instar varied greatly depending on conditions under which the larvae fed, including time of day and concentration of particles available. Because movement of material through the guts is a direct measurement of ingestion, and increases with instar (and size of larva), they consider relative rates of ingestion, for example, percentage of gut filled, to vary with instar.

Elsen and Elouard (1975) experimented on larvae of *S. damnosum* in beakers of water through which air was bubbled, and to which particles were added at the beginning of each experiment. The velocity of water to which the larvae were exposed was not recorded and probably varied

between larvae depending on where in the beakers the larvae were attached. In another experiment carried out in natural watercourses, they demonstrated that rates of movement of gut contents increased when larvae were exposed to greater concentrations of particles and faster water velocities.

Mulla and Lacey (1976) studied the feeding behaviour of larvae of three species of black flies, *Simulium argus*, *Simulium tescorum* and *Simulium vittatum*. They found that the rate of movement of material through the gut was faster among early instars of all three species. Mulla and Lacey performed their experiments in natural watercourses. They did not estimate the concentration of particles to which the larvae were exposed, nor record how close to larvae they measured water velocity. Under natural conditions, it is possible that larvae of different instars were exposed to different availabilities of particles. They also found differences in rate of movement of gut contents between populations of larvae occurring in different watercourses. Temperature, water velocity, and probably concentration of particles, differed between these watercourses.

The variation of percentage gut filled within each larval class is high (Appendix F, table 2.4.), and thus may prevent real differences between percentage gut filled among experiments from being identified statistically. However, differences between means of arcsine percentage gut filled when tested using Duncan's New Multiple Range Test were not significant (sect. 2.3.2., Appendix G).

There is no evidence here of periods of peak feeding activity identified by Phelps and DeFoliart (1964) on field populations of *Simulium vittatum*. The present study took six weeks on an overwintering population in which the rate of development was reduced. Temperature of the water was below that for maximum rate of feeding (Webster 1973), but above that in which feeding is greatly reduced (Ladle et al 1972, Mansingh et al 1972).

2.4.4.3. Ingestion within larval class

Larvae in all classes ingest most particles at similar availabilities, 100 - 200 particles/cm²/sec. Both small and large parasitized larvae ingest equally when exposed to a wide range of availabilities. Among small larvae this may be because these larvae have a wider range of suitable attachment sites, or because they are exposed to lower particle availabilities. In natural watercourses small larvae of several species of black flies are found in area of flow slower than areas in which larger larvae occur (Maitland and Penn

Because of their size, small larvae are more protected by the boundary layer than are larvae of the other classes. They are exposed to slower velocities and less variations in current. They are also exposed to a smaller range of [p] 's since the distribution of particles in the water is dependent on velocity.

Another explanation for the lack of differences in ingestion by small larvae among experiments involves an alternative method of feeding. Black fly larvae scrape the substratum around their site of

attachment free of algae and accumulating materials. This behaviour has been reported several times (Chance 1970a) and has been considered both as an artifact of rearing conditions (Wu 1931), and as occurring only when larvae are exposed to adverse conditions (Badcock 1949, Zahar 1951). However, Peterson (1956) and Serra-Tosio (1967) maintained that it is a normal method of feeding. Recent observations carried out on larvae in a benthobservatory indicate that larvae spend a considerable part of their time scraping the substratum (Mokry 1975). Such feeding behaviour is less influenced by water velocity and [p] than filter-feeding and is perhaps used by small larvae to a greater extent than by larvae of other classes. Because particles became stuck in the salivary secretion produced by larvae for attachment, any larvae scraping the substratum would be exposed to a plentiful supply of particles. Small larvae, including first instars, however, do filter-feed.

The greater tolerance of large parasitized larvae to experimental conditions may be explained by the effects of parasitism. Little is known about the physiological effects of parasitism, however, Strickland (1913) observed that black fly larvae parasitized by mermithids tend to suffer a loss of muscle tissue and are sluggish. He reported that when larvae were transferred to new containers, they did not make any exploratory movements but began to feed almost immediately. They fed more often and became larger. (Parasitized larvae tend to have a retarded rate of development (Strickland 1911, 1913; Phelps and DeFoliart 1964; Peterson 1956; Maurand 1975).) If larvae sense the force of the current through their muscular system, as suggested by

Fortner (1937), parasitism may reduce their ability to sense the current and their response to it. As a result, parasitized larvae may accept a greater range of velocity and [p] than healthy larvae.

Large larvae spend more time feeding. Although they are more efficient than small and medium larvae, they require greater amounts of food. Parasitized larvae are less efficient than healthy and smaller larvae, and probably require even more food to support a parasite in addition to a larger size.

Maximum ingestion at low availability of particles is due to preference of the larvae for slow velocity and low [p]. At temperatures of 9 - 10°C larvae ingested most rapidly under concentrations of 4 - 40 particles (20 - 40 μm in diameter)/ml and at velocities of 5 - 10 cm/sec. These velocity values are much lower than those measured by Kurtak for the feeding activity of *S. vittatum* larvae. Several factors probably account for the differences: measurement technique, temperature of the water, and heterogeneity within the species.

With increasing availability of particles, ingestion by larvae is reduced. Fewer larvae may feed (sect. 2.4.4.6.). Under high [p] fans may become clogged with too many particles and therefore become less efficient. Larvae may also spend more time cleaning their fans and mouthparts. Particles are sometimes swept out of the fans before they are retained by the mouthparts (Chance 1970a). At fast velocities, particles may be travelling too fast to be caught by the fans. Kurtak described how the paths of particles travelling through the fans of

Simulium pictipes are dispersed in slow velocities but not in fast velocities.

Larvae of *Simulium vittatum* have a low velocity preference compared to that of other species studied. They are found in variety of habitats but generally in slow flowing water (Fredeen 1959, Anderson and Dicke 1960), and feed at lower velocities (Kurtak 1973). The range of availability of particles (of the size used in this study) at which larvae fed equally well not only reflects the cosmopolitan nature of this species, but also the range of particle concentrations occurring in natural waters.

Kurtak determined the efficiency of ingestion for 9 species of black fly larvae. This efficiency (defined in footnote, page 79) decreased with increasing velocity (of 20, 50, and 70 cm/sec) when larvae were exposed to particles of similar and larger diameters at similar or greater concentrations. Efficiency of ingestion varied with type of particle, with species, and with the population of *Simulium vittatum* studied. Most of his work was on larvae of *S. pictipes*, among which efficiency of ingestion also decreased with increasing [p].

Elouard and Elsen (1975) found that larvae of *Simulium damnosum* fed more rapidly when exposed to higher [p]'s (while maintained in beakers in which water was circulated slowly by means of an air stone) and more rapidly when exposed to faster velocities (in natural water-courses). Similarly, Mulla and Lacey (1976) found faster rates of ingestion by various *Simulium* larvae, including *S. vittatum*, when larvae were exposed to faster velocities.

However, neither Elouard and Elsen, nor Mulla and Lacey made precise measurements of both water velocity and $[p]$ for any experiment. Thus the availability of particles to which the larvae were exposed is not known. Conditions to which larvae were exposed and techniques of measurement differ between studies. Therefore detailed comparisons of the results of these studies are not possible, and the importance of any discrepancies in results is difficult to assess. These studies do show that rates of ingestion by larvae are dependent on conditions to which the larvae are exposed, and vary with species and possibly with age of larvae.

2.4.4.4. Ingestion within larval class among periods of feeding

Because feeding is measured on the basis of percentage gut filled, and because rate of progression of material through the gut is dependent on the rate of ingestion of substrate filtered material, the mean percentage gut filled is expected to be greater the longer larvae feed. However under the conditions of the 'doubled' experiments, efficiency of ingestion varies over the longer time period of each experiment because efficiency varies with $[p]$. When the second colour of particles was added to the water, larvae were suddenly exposed to a greatly increased $[p]$. The decrease in rate of ingestion results in a lower percentage gut filled over the longer period of time. Thus larvae feeding for 60 and 90 minutes will not ingest 2-3 times that ingested by larvae during 30 minutes.

Larvae which did not feed during the first period of a 'doubled' experiment will have less or no difference in percentage gut

filled between parts of the experiment. Larvae of classes with a wider tolerance to $[p]$, for example, large parasitized larvae, show less difference in ingestion between parts of 'doubled' experiments.

2.4.4.5. Ingestion under similar conditions

Comparisons of experiments in which either velocity or $[p]$ was similar show that medium larvae are more sensitive to differences in either velocity or $[p]$ than are larvae of the other classes. After 30 minutes medium larvae ingested more when exposed to 19 cm/sec and 35.15 particles/ml (availability of 668) than when exposed to 34.8 cm/sec and 36.5 particles/ml (availability of 1270) (fig. 2.3g, #3, #4b). There were no differences in ingestion among larvae of the other classes; these ingested equally well under 19 cm/sec as under 34.5 cm/sec. Similarly, medium larvae ingested more under 9.7 cm/sec and 11.9 particles/ml (availability of 115, #7) than under 19.4 cm/sec and 13.7 particles/ml (availability of 266, #2); larvae of other classes ingested equally well under both velocities.

During experiments with similar velocities but different $[p]$'s, large and medium larvae ingested more under lower $[p]$; small and large parasitized larvae ingested equally well under both $[p]$'s. After 60 minutes, large and medium larvae ingested more when exposed to lower $[p]$ in slower velocities (figs. 2.3e, h; #8a, #15a, #13b, #14a). However, after 90 minutes, large and medium larvae ingested more at faster velocity, 17.2 cm/sec, than at 8.5 cm/sec at $[p]$ of approximately 10 particles/ml (figs. 2.3e, h; #11a, #5a). In these experiments, the availability of particles at the faster velocity, 184, was closer to the optimal

availability than that at the slower velocity, 85,

Large parasitized larvae also ingested more at a slower velocity, 3.7 cm/sec, than at a higher velocity, 28.4 cm/sec, when exposed to similar [p] 's (#13b, 14a). In other comparisons, large parasitized and small larvae ingested similar amounts.

2.4.4.6. Proportions of larvae which did not feed

The percentage of unfed larvae varies with larval class and with conditions to which the larvae are exposed. The tests of independence show that feeding, and therefore lack of feeding, varies greatly with experiment and with larval class (sect. 2.3.3.2.vi). As in studies of ingestion, medium larvae are more sensitive to experimental conditions with respect to feeding than are other classes, and large parasitized larvae are least sensitive (sect. 2.3.3.2.vi).

Experimental conditions influenced feeding among all classes similarly. The percentage of unfed larvae in each class is dependent on availability of particles. In any one experiment, availability of particles is assumed to be equal for all larvae. Variations in particle distribution throughout the duration of an experiment probably did occur, however, due to differences in velocity of water; but this variation would depend on variations in velocity over the area of the flume and is expected to be small. If larvae did not feed simply because they were not exposed to particles (because of an uneven distribution in the water), the percentage of unfed larvae would be much less. The distribution of percentage gut filled (including larvae with

0% gut filled) would approximate a normal distribution more closely.

Rough estimates¹ of the numbers of particles to which larvae were exposed over the feeding periods range from 113,350 for large larvae under low particle availabilities to 5,900,000 for large larvae under high particle availabilities. Because of their smaller fans small larvae were exposed to approximately 24% of these numbers. Even at the low feeding efficiency of 1%², larvae of all classes had ample opportunity of ingesting at least some particles.

The influence of availability of particles on the percentage of unfed larvae is reflected in the decrease in proportion of unfed larvae with time. This decrease occurred when larvae are exposed to similar velocities and [p]'s. When larvae are exposed to slow velocity and moderate [p], the percentage of unfed larvae does not decrease with time for larvae of all classes. These differences as well as ones within doubled experiments are explained by the varying proportions of larvae in each class feeding for different times during some of the experimental period.

Availability of particles influences similarly both the proportion of the population that fed and the extent of feeding, in all classes of larvae. Although the percentage of unfed larvae varied among classes, high proportions of larvae in all classes did not feed in some

¹Estimate = vel. (mm/sec) X frontal area of both fans (mm²) X [p] (particles/ml) X duration of experiment (sec).

²Overall efficiency of feeding by individual black fly larvae ranges from 1 - 10% (Kurtak 1973).

experiments, and low proportions of larvae in all classes did not feed in other experiments. Larvae which fed, fed proportionally the same amount in all classes.

During the longer experiments in which a high proportion of larvae fed, they tended to ingest more. However, there is no significant correlation between the proportion of larvae which fed and the mean (arcsine) percentage gut filled. Although availability of particles influences both feeding and extent of feeding, other factors in addition to availability of particles must determine whether or not a larva feeds.

The results of the 90 minute experiments agree in part with those of Elouard and Elsen (1975). Under conditions in which larvae ingested at a greater rate, a larger proportion of the larvae of *S. damnosum* fed. However, Elouard and Elsen found no relationship between the percentage of unfed larvae and larval instar (or larval class).

There is little relationship between percentage gut-filled percentage of unfed larvae in each experiment for the 30 and 60 minute feeding periods. This suggests that the period during which larvae do not feed may extend up to 60 minutes or so but the proportion of larvae which do not feed at any one time in a population of larvae feeding for longer periods (i.e. under normal conditions) is more or less constant, although varying with conditions of feeding.

Differences in percentage unfed larvae with larval class is not a reflection of relative ingestion efficiencies of larvae since large parasitized larvae are less efficient at ingesting particles yet a

higher percentage of them fed. It is reasonable to assume that larvae with 0% gut filled did not ingest any particles because they were not filtering throughout their exposure to particles. Lack of feeding among larvae is a behavioral phenomenon rather than an artifact of the experimental design.

Although larvae have been considered to filter more or less continuously, in fact they do not feed all the time (Dethier 1966, Glötzel 1973). They spend time grooming themselves, cleaning their fans and mouthparts, and changing their site of attachment. Times larvae spend on various activities have never been measured in detail. They may spend as much time scraping the substratum and on other non-feeding activities as they do on filtering, although they never spend more than a few moments at a time on any one activity (Mokry 1975). The duration of periods larvae spend flicking (opening and closing) and cleaning their fans, and keeping their fans extended, varies greatly (Chance 1970a). The frequency of fan flicking is irregular, however, it does not appear to vary with class or between larvae with full guts and larvae with empty guts (Chance 1969).

Fredeen (1964) noted that a few larvae of *Simulium venustum* did not feed during his laboratory studies of larval diets. These unfed larvae pupated within a few hours. Larvae studied here were from an overwintering population in which pupation was delayed until spring. Mullá and Lacey (1976) also found larvae of *Simulium vittatum*, *S. argus* and *S. tescorum* which did not ingest synthetic particles over periods of 30 - 60 minutes. Elouard and Elsen (1975) reported that a

proportion of *S. damnosum* larvae did not feed during an experimental period of two hours. They attributed this to a non-uniform distribution of synthetic particles in the water or a lack of filtering.

The higher proportion of unfed small larvae than unfed larvae of other classes implies that these larvae either are exposed to lower availabilities of particles or they spend less time feeding. Because of their smaller size, small larvae filter a smaller volume of water and, in addition, are exposed to slower velocities and therefore lower particle availabilities. They may also spend less time filtering. Mókry (1975) observed that the first three instars of *Simulium venustum* normally spend more time migrating than later instar larvae.

Lack of feeding of varying periods of time contributes to the variation in average percentage gut filled. Other factors which contribute to this variation also contribute to the proportion of unfed larvae, including differences in behaviour between larvae, differences in efficiency of ingestion, and differences (if any) in availability of particles. Differences in feeding activity may also be a factor.

The failure of larvae to feed for periods of 90 minutes or more is important in connection with control programmes in which particulate formulations of larvicides are added to natural watercourses. If populations are exposed to a larvicide for only a few minutes, larvae which are not filtering will not be affected.

2.5. CONCLUSION

Larvae of *Simulium vittatum* ingest most rapidly when exposed to relatively low availabilities of particles, under water velocities of 5 - 10 cm/sec and particle concentrations of 4 - 40 particles/ml. Rate of gut filling decreases when larvae are exposed to faster velocities or higher particle concentrations. Rate of ingestion by larvae varies with larval size; however, rate of gut filling is equal unless larvae are exposed to fast velocities or high particle concentrations. This is of interest in connection with control programmes involving particulate larvicides. Since LD_{50} 's probably vary with larval size, all larvae may be equally susceptible to the same dosage of pesticide. If mixing of pesticides were uniform in the water, which Wallace et al. (1941) has shown does not occur, larvae of all sizes would likely be affected.

Larvae of *S. vittatum* do not feed continuously. Proportions of larvae of each class do not feed for various periods, extending up to 90 minutes and longer. The proportions of unfed larvae also vary with larval class, decreasing with increasing size of larva. Lack of feeding is a behavioural phenomenon rather than the result of a lack of opportunity to catch particles. This too must affect the success of larviciding programmes because larvae which are not filtering will not ingest particulate pesticides carried by the water.

Small larvae are apparently less sensitive to conditions to which they are exposed than larvae of other classes. They are less likely to

be affected by particulate pesticides carried by the water. If they feed extensively by scraping the substratum, they may be exposed to more or less pesticide, depending on the distribution of the pesticide on the substratum.

Parasitism decreases filtering efficiency, but higher proportions of parasitized larvae feed at any particular time. Thus parasitized larvae are probably more vulnerable to particulate larvicides than healthy larvae.

Medium larvae are most sensitive to conditions to which they are exposed. Large larvae are more efficient filterers.

Indirect evidence from one experiment (#1a, b) suggests that feeding activity varies over the 24 hour period and in larval *S. vittatum* is depressed at night.

These results are of importance in control programmes in which particulate insecticides are used. Reduced feeding efficiency under fast velocities and high particle concentrations will result in low levels of kill. Chemicals will be wasted unless they are administered effectively, for example, against *S. vittatum*, at relatively low concentrations over long periods of time, so that larvae are exposed for 60 minutes or longer.

Adults of *Simulium vittatum* are a nuisance when abundant, but the species is not a major pest species. Most black fly problems are caused by other species of black flies, the larvae of which may feed

most efficiently under different conditions. Since particulate formulations of insecticides are more effective and selective against black fly larvae than are other formulations (Chance 1970b), influence of velocity and particle concentration on larval feeding is of prime importance.

3.0. GENERAL CONCLUSION

Black fly larvae occupy the relatively harsh environment of a lotic habitat. They achieve this through adaptations which reduce the severity of lotic hazards and by taking advantage of special features of their environment.

The fundamental feature of lotic habitats is the flow of water. This creates a mechanical danger which lotic organisms must either avoid or overcome. Anatomical and behavioural adaptations enable black fly larvae to withstand the force of the current. The velocity gradient and substrate boundary layer provide larvae with protection from fast water velocities and at the same time allow larvae to feed without expending very much energy.

The passive filter-feeding behaviour of black fly larvae is a consequence of life in a lotic habitat. Larvae filter particles carried by the current. The rate at which larvae feed is determined by rate of water flow and concentration of available food.

4.0. LITERATURE CITED

- Alexander, R. McN. 1971. Animal mechanics. Sidgwick and Jackson, London. 346 pp.
- Alexander, R. McN. 1973. Size and shape. Studies in Biology no. 9. Edward Arnold, Ltd., London. 59 pp.
- Allan, W.H. 1961. Underwater flow visualization techniques. NAVWEPS REPORT 7778 NOTS Technical Publication 2759. U.S. Naval Ordnance Test Station. China Lake. 2700.
- Allen, K.R. 1951. The Horokiwi Stream. Fish. Bull. N.Z. 10. 331 pp.
- Allen, K.R. 1959. The distribution of stream bottom fauna. N.Z. ecol. Soc. 6: 5-8.
- Ambühl, H. 1959. Die Bedeutung der Strömung als ökologischer Faktor. Schweiz. Z. Hydrol. 21: 133-265.
- Ambühl, H. 1961. Die Strömung als physiologischer und ökologischer Faktor. Verh. int. Verein. theor. angew. Limnol. 14: 390-395.
- Ambühl, H. 1962. Die Besonderheiten der Wasserströmung in physikalischer, chemischer und biologischer Hinsicht. Schweiz. Z. Hydrol. 24: 367-382.
- Anderson, J.R. and R.J. Dicke. 1960. Ecology of the immature stages of some Wisconsin blackflies (Simuliidae: Diptera). Ann. ent. Soc. Amer. 53: 386-404.
- Badcock, R.M. 1949. Studies in stream life in tributaries of the Welsh Dee. J. Anim. Ecol. 18: 193-208.
- Bailey, C.M. and R. Gordon. 1977. Observations on the occurrence and collection of mermithid nematodes from black flies (Diptera: Simuliidae). Can. J. Zool. 55: 148-154.
- Barber, W.E. and N.R. Kevern. 1973. Ecological factors influencing macroinvertebrate standing crop distribution. Hydrobiologica 43: 53-75.
- Becker, C.D. 1973. Development of *Simulium (Psilozia) vittatum* Zett. (Diptera: Simuliidae) from larvae to adults at thermal increments from 17.0 to 27.0 C. Amer. midl. Nat. 89: 246-251.

- Bournaud, M. 1963. Le courant, facteur ecologique et éthologique de la vie aquatique. *Hydrobiologia* 21: 125-165.
- Bournaud, M. 1972. Influence de la vitesse de courant sur l'activité de locomotion des larves de *Micropterna testacea* (Gmel.) (Trichoptera, Limnephiliidae). *Ann. de Limnol.* 8: 141-216.
- Brundritt, J.K. 1971. A device for determining velocity of flow near the substrate. *Limnol. Oceanogr.* 16: 120-123.
- Carlsson, G. 1962. Studies on Scandinavian blackflies. *Opusc. ent. suppl.* 21. 279 pp.
- Carlsson, G. 1967. Environmental factors influencing black fly populations. *Bull. Wld Hlth Org.* 37: 139-150.
- Chance, M.M. 1969. Functional morphology of the mouthparts of black fly larvae (Diptera: Simuliidae). M.Sc. thesis, Univ. Alberta. 132 pp.
- Chance, M.M. 1970a. The functional morphology of the mouthparts of black fly larvae (Diptera: Simuliidae). *Quaest. ent.* 6: 245-284.
- Chance, M.M. 1970b. A review of chemical control methods for black fly larvae (Diptera: Simuliidae). *Quaest. ent.* 6: 287-292.
- Chapman, H.E. 1973. Assessment of the potential of some pathogens and parasites of biting flies. p. 71-77. In Hudson, A. (ed.) *Symposium on biting fly control and environmental quality.* University of Alberta, Edmonton, May 1972. Defence Research Board, Ottawa, DR 217.
- Chaston, I. 1968. Endogenous activity as a factor in invertebrate drift. *Arch. Hydrobiol.* 64: 324-334.
- Chutter, F.M. 1968. On the ecology of the fauna of stones in the current in a South African river supporting a very large *Simulium* (Diptera) population. *J. appl. Ecol.* 5: 531-561.
- Clemens, W.A. 1917. An ecological study of the mayfly *Chirotenetes*. *Univ. Toronto Stud. biol. Ser.* 17. 43 pp.

- Corbet, P.S. 1967. The diel oviposition periodicity of the black fly, *Simulium vittatum*. *Can. J. Zool.* 45: 583-584.
- Couvert, L. 1970. Studia morfologico delle capsule cefaliche delle larve di *Prosimulium conistylum* Rubsov and *Liponeura cinerascens* Loew. *Mem. Soc. ent. Ital.* 49: 159-188.
- Craig, D.A. 1974. The labrum and cephalic fans of larval Simuliidae (Diptera:Nematocera). *Can. J. Zool.* 52: 133-159.
- Crisp, D.J. and A.J. Southward. 1956. Demonstration of small scale water currents by means of milk. *Nature, London.* 178: 1076.
- Crisp, D.J. and A.J. Southward. 1961. Different types of cirral activity of barnacles. *Phil. Trans. R. Soc. Lond. B.* 243: 271-307.
- Cummins, K.W. 1962. An evaluation of some techniques for the collection and analysis of benthic samples with special emphasis on lotic waters. *Amer. midl. Nat.* 67: 477-504.
- Cummins, K.W. and G.H. Lauf. 1969. The influence of substrate particle size on the microdistribution of stream macrobenthos. *Hydrobiologia* 34: 145-181.
- Dadd, R.H. 1968. A method for comparing feeding rates in mosquito larvae. *Mosq. News* 28: 226-230.
- Dadd, R.H. 1970a. Comparison of rates of ingestion of particulate solids by *Culex pipiens* larvae: phagostimulant effect of water-soluble yeast extract. *Ent. exp. appl.* 13: 407-419.
- Dadd, R.H. 1970b. Relationship between filtering activity and ingestion of solids by larvae of the mosquito *Culex pipiens*: a method for assessing phagostimulant factors. *J. med. Ent.* 7: 708-712.
- Dadd, R.H. 1971. Effects of size and concentration of particles on rates of ingestion of latex particles by mosquito larvae. *Ann. ent. Soc. Amer.* 64: 687-692.
- Davies, D.M. and P.D. Syme. 1958. Three new Ontario black flies of the genus *Prosimulium* (Diptera:Simuliidae). II: Ecological observations and experiments. *Can. Ent.* 90: 744-759.

- Davies, L. 1961. Ecology of 2 *Prosimulium* species (Diptera) with reference to their ovarian cycles. *Can. Ent.* 93: 1113-1140.
- Davies, L. 1974. Evolution of larval head-fans in Simuliidae (Diptera) as inferred from the structure and biology of *Crozetia crozetensis* (Womersley) compared with other genera. *Zool. J. Linn. Soc.* 55: 193-224.
- Dethier, V.G. 1966. Feeding behaviour, p. 46-58. In Haskell, P.T. (ed.) *Insect behaviour. Symp. R. ent. Soc. Lond.* 3. 1113 pp.
- Dorier, A. and F. Vaillant. 1954. Observations et expériences relatives à la résistance au courant de divers invertébrés aquatiques. *Trav. Lab. Hydrobiol. Piscic. Univ. Grenoble* 45/6: 9-31.
- Downes, J.A. 1973. Biting flies: the necessity for a new systematics. p. 115-123. In Hudson, A. (ed.) *Symposium on biting fly control and environmental quality, University of Alberta, Edmonton, May 1972. Defence Research Board, Ottawa.* DR 217.
- Dumbleton, L.J. 1972. The genus *Autrosimulium* Tonnoir (Diptera: Simuliidae) with particular reference to the New Zealand fauna. *N.Z. J. Sci.* 15: 480-584.
- Edington, J.M. and L. Molyneux. 1960. Portable water velocity meter. *J. Sci. Instr.* 37: 455-457.
- Elliott, J.M. 1967. Invertebrates in a Dartmoor stream. *Arch. Hydrobiol.* 63: 202-237.
- Elliott, J.M. 1969. Diel periodicity in invertebrate drift and the effect of differential sampling periods. *Oikos* 20: 524-528.
- Elliott, J.M. 1970. The distances travelled by drifting invertebrates in a Lake District stream. *Oecologia* 6: 350-379.
- Elliott, J.M. 1971. Upstream movements of benthic invertebrates in a Lake District stream. *J. Anim. Ecol.* 40: 235-252.
- Elouard, J.M. and P. Elsen. 1975. Variation de l'absorption des particules alimentaires et de la vitesse du transit digestif au cours d'un nyctémère chez les larves du *Simulium dammosum* Theobald, 1903 (Diptera: Simuliidae). ORSTOM Report 623/1975 (unpublished).
- Eriksen, C.H. 1966. Benthic invertebrates and some substrate-current-oxygen inter-relationships. *Spec. Publ. Pymatuning Lab Ecol.* 4: 98-115.
- Fortner, G. 1937. Zur Ernährungsfrage der *Simulium* larva. *Zeitschr. Morph. u. Ökol. Tiere.* 32: 360-383.

- Fredeen, F.J.H. 1959. Rearing black flies in the laboratory (Diptera: Simuliidae). *Can. Ent.* 91: 73-83.
- Fredeen, F.J.H. 1960. Bacteria as a source of food for black-fly larvae. *Nature* 187: 963.
- Fredeen, F.J.H. 1964. Bacteria as food for black fly larvae (Diptera: Simuliidae) in laboratory culture and in natural streams. *Can. J. Zool.* 42: 527-548.
- Fredeen, F.J.H. and J. Shemanchuck. 1960. Black flies (Diptera: Simuliidae) of irrigation systems in Saskatchewan and Alberta. *Can. J. Zool.* 38: 723-735.
- Gessner, F. 1950. Die ökologische Bedeutung der Strömungsgeschwindigkeit fleissender Gewässer und ihre Messung auf kleinstem Raum. *Arch. Hydrobiol.* 43: 159-165.
- Glötzel, R. 1973. Populationsdynamik und Ernährungsbiologie von Simuliidenlarven in einem mit organischen Abwässern verunreinigten Gebirgsbachs. *Arch. Hydrobiol. suppl.* 42: 406-451.
- Grenier, P. 1949. Contribution à l'étude biologique des simuliides de France. *Physiologica comp. Oecol.* 1: 314 pp.
- Harrod, J.J. 1965. Effect of current speed on the cephalic fans of larvae of *Simulium ornatum* var. *nitidifrons* Edwards (Diptera: Simuliidae). *Hydrobiologia* 26: 8-12.
- Hersh, G.L. 1960. A method for the study of the water currents of invertebrate ciliary filter feeders. *Veliger* 2: 77-83.
- Hocking, B. and L.D. Pickering. 1954. Observations on the bionomics of some northern species of Simuliidae (Diptera). *Can. J. Zool.* 32: 89-119.
- Hora, S.L. 1927. The mechanism of the so-called 'posterior sucker' of a *Simulium* larva. *Nature, London.* 119: 599-600.
- Hubault, E. 1927. Contribution à l'étude des invertébrés torrenticoles. *Bull. biol. Fr. Belg. suppl.* 9: 390 pp.
- Hynes, H.B.N. 1970a. The ecology of running waters. Univ. Toronto Press, Toronto. 555 pp.
- Hynes, H.B.N. 1970b. The ecology of stream insects. *Ann. Rev. Ent.* 15: 25-42.

- Inman, D.L. 1949. Sorting of sediments in the light of fluid mechanics. *J. sed. Petr.* 19: 51-70.
- Jaag, O. and H. Ambühl. 1964. The effect of the current on the composition of biocenosis in flowing water streams. *Advances in water pollution research* 1: 31-49.
- Jørgensen, C.B. 1966. Biology of suspension feeding. Pergamon Press, London. 358 pp.
- Jørgensen, C.B. 1975. Comparative physiology of suspension feeding. *Ann. Rev. Physiol.* 37: 57-79.
- Kullback, S. 1968. Information theory and statistics. Dover Publications, Inc., New York. 399 pp.
- Kureck, A. 1969. Tagesrhythmen lappländischer Simuliiden (Diptera). *Oecologia* 2: 385-410.
- Kurtak, D.C. 1973. Observations on filter feeding by the larvae of black flies (Diptera: Simuliidae). Ph.D. thesis, Cornell University. 158 pp. University Microfilms, Ann Arbor, Michigan 74-7202.
- Ladle, M. 1972. Larval Simuliidae as detritus feeders in chalk streams. *Mem. Ist. Ital. Idrobiol. suppl.* 29: 429-439.
- Ladle, M., J.A. Bass and W.R. Jenkins. 1972. Studies on production and food consumption by the larval Simuliidae (Diptera) of a chalk stream. *Hydrobiologia* 30: 429-448.
- Lewis, D.J. 1953. Simuliidae in the Anglo-Egyptian Sudan. *Revue Zool. Bot. afr.* 48: 269-286.
- Lewis, D.J. and G.F. Bennett. 1975. The black flies (Diptera: Simuliidae) of insular Newfoundland. III. Factors affecting the distribution and migration of larval simuliids in small streams on the Avalon Peninsula. *Can. J. Zool.* 53: 114-123.
- Maitland, P.S. and M.M. Penney. 1967. The ecology of the Simuliidae in a Scottish river. *J. Anim. Ecol.* 36: 179-206.
- Mansingh, A., R.W. Steele and B.V. Helson. 1972. Hibernation in the black fly *Prosimulium mysticum*: quiescence or oligopause? *Can. J. Zool.* 50: 31-34.

- Mansingh, A. and R.W. Steele. 1973. Studies on insect dormancy. I. Physiology of hibernation in the larvae of the black fly *Prosimulium mysticum* Peterson. Can. J. Zool. 51: 611-618.
- Maurand, J. 1975. Les microsporidies des larvres de Simulies. Ann. Parasit. hum. comp. 50: 371-396.
- McConnell, W.J. and W.F. Sigler. 1959. Chlorophyll and productivity on a mountain river. Limn. Ocean. 4: 335-351.
- Mokry, J.E. 1975. Studies on the ecology and biology of blackfly larvae utilizing an *in situ* benthobservatory. Verh. internat. Verein. Limnol. 19: 1546-1549.
- Mokry, J.E. 1976. Laboratory studies on the larval biology of *Simulium venustum* Say. (Diptera:Simuliidae). Can. J. Zool. 54: 1657-1663.
- Molloy, D. and H. Jamnback. 1975. Laboratory transmission of mermithids parasitic in black flies. Mosq. News 35: 337-342.
- Mulla, M.S. and L.A. Lacey. 1976. Feeding rates of *Simulium* larvae on particles in natural stream (Diptera:Simuliidae). Env. Ent. 5: 283-287.
- Nauman, G. 1924. Notizen zur Ernährungsbiologie der limnischen Fauna. Arkiv. für Zool. 16: 1-14.
- Nevue, A. 1972. Introduction à l'étude de la faune des diptères à larvres aquatiques d'un ruisseau des Pyrénées Atlantiques, Le Lissuraga. Ann. Hydrobiol. 3: 173-196.
- Nevue, A. 1973a. Variations biometriques saisonnières chez les adults de quelques espèces de Simuliidae (Diptera:Nematocera). Archiv. Zool. expt. gén. 114: 261-270.
- Nevue, A. 1973b. Le cycle de développement des Simuliidae (Diptera: Nematocera) d'un ruisseau des Pyrénées Atlantiques, Le Lissuraga. Ann. Hydrobiol. 4: 51-75.
- Nevue, A. 1973c. Estimation de la production de populations larvaires du genre *Simulium* (Diptera:Nematocera). Ann. Hydrobiol. 4: 183-199.
- Pasternak, J. 1964. Chromosomal polymorphism in the black fly *Simulium vittatum* (Zett.). Can. J. Zool. 42: 135-158.

- Peterson, B.V. 1956. Observations on the biology of Utah black flies (Diptera:Simuliidae). *Can. Ent.* 88: 496-507.
- Peterson, B.V. 1960. Notes on some natural enemies of Utah black flies (Diptera:Simuliidae). *Can. Ent.* 92: 266-274.
- Phelps, R.J. and G.R. DeFoliart. 1964. Nematode parasitism of Simuliidae. *Res. Bull. Univ. Wisconsin (Sci. Ser.)* no. 245. 78 pp.
- Phillipson, J.A. 1956. A study of factors determining the distribution of larvae of the black fly, *Simulium ornatum* Mg. *Bull. ent. Res.* 47: 227-238.
- Phillipson, J.A. 1957. The effect of current speed on the distribution of larvae of the black fly, *Simulium variegatum* (Mg.) and *Simulium monticola* (Freid.) (Diptera). *Bull. ent. Res.* 48: 811-819.
- Puri, I.M. 1925. On the life history and structure of the early stages of Simuliidae (Diptera:Nematocera). I. *Parasitology* 17: 295-337.
- Raastad, J.E. and R. Mehl. 1973. Night activity of black flies (Diptera, Simuliidae) in Norway. *Norsk. ent. Tidssk.* 19: 173.
- Reisen, W.K. 1974. The ecology of Honey Creek. A preliminary evaluation of the influence of *Simulium* spp. (Diptera: Simuliidae) larval populations on the concentration of total suspended particles. *Ent. News* 85: 275-278.
- Rubtsov, I.A. 1965. (The early spring and winter fauna of Simuliidae.) *Zool. Zh.* 44: 1485-1496. (English summary).
- Rubtsov, I.A. 1966. Host-parasite interrelationships relationships. Responses of simuliids to microsporidia taken as example. *Zh. Obstich. Biol.* 27: 647-661. (English summary).
- Ruttner, R. 1963. *Fundamentals of limnology*. Transl. D.G. Frey and F.E.J. Fry. Univ. Toronto Press, Toronto. 295 pp.
- Schwoerbel, J. 1971. Produktionsbiologie Aspekte in Fließgewässern. *Verh. Dtsch. Zool. Ges.* 65: 57-65.
- Scott, D. 1958. Ecological studies on the Trichoptera of the River Dean, Cheshire. *Arch. Hydrobiol.* 54: 340-392.
- Serra-Tosio, B. 1967. La prise de nourriture chez la larve de *Prosimulium inflatum* Davies, 1957 (Diptera:Simuliidae). *Trav. Lab. Hydrobiol.* 57/58: 97-103.

- Shapiro, A.H. 1961. Shape and flow. Doubleday, Garden City, N.Y. 186 pp.
- Smith, C.D. 1969. The effects of temperature on certain life stages of Simuliidae (Diptera). M.Sc. thesis, University of Durham, England. 122 pp.
- Sokal, R.R. and F.J. Rohlf. 1969. Biometry. W.A. Freeman and Co., San Francisco. 776 pp.
- Sommerman, K.M., R.I. Sailer and C.O. Esselbaugh. 1955. Biology of Alaskan black flies. Ecol. Mon. 25: 345-385.
- Steel, R.G.D. and J.H. Torrie. 1960. Principles and procedures of statistics. McGraw Hill, Toronto. 481 pp.
- Strickland, H. 1911. Some parasites of *Simulium* larvae and their effect of the development of the host. Biol. Bull. 21: 302-338.
- Strickland, H. 1913. Some parasites of *Simulium* larvae and their possible economic value. Can. Ent. 45: 405-413.
- Thorup, J. 1974. Occurrence and size-distribution of Simuliidae (Diptera) in a Danish spring. Arch. Hydrobiol. 3: 316-335.
- Tonnoir, A. 1922. Notes sur la biologie des larves de *Simulium* (Diptera). Ann. de Biol. lac. 11: 163-172.
- Tonnoir, A. 1925. Australasian Simuliidae. Bull. ent. Res. 15: 213-255.
- Trivellato, D. and H. Décamps. 1968. Influence de quelques obstacles simples sur l'écoulement dans un 'ruisseau' expérimental. Ann. Limn. 4: 357-386.
- Ulfstrand, S. 1967. Microdistribution of benthic species (Ephemeroptera, Plecoptera, Trichoptera, Diptera: Simuliidae) in Lapland streams. Oikos 18: 293-310.
- Ulfstrand, S. 1968a. Benthic animal communities in Lapland streams. Oikos suppl. 10. 120 pp.
- Ulfstrand, S. 1968b. Life cycles of benthic insects on Lapland streams. (Ephemeroptera, Plecoptera, Trichoptera, Diptera: Simuliidae). Oikos 19: 167-190.

- Wallace, R.R., A.S. West, A.E.R. Downe and H.B.N. Hynes. 1973. The effects of experimental black fly (Diptera:Simuliidae) larviciding with Abate, Dursban and methoxychlor on stream invertebrates. *Can. Ent.* 105: 817-831.
- Webster, J.M. 1973. Manipulation of environment to facilitate use of nematodes in biocontrol of insects. *Exp. Parasit.* 33: 197-206.
- Welch, P.S. 1948. *Limnological methods*. McGraw-Hill Book Co., N.Y. 381 pp.
- Welch, H.E. 1964. Mermithid parasites of black flies. *Bull. Wld Hlth Org.* 34: 857-863.
- Welch, H.E. and G.O. Poinar, Jr. 1964. The role of nematodes in the regulation and control of insects of medical importance. *Proc. 12th int. Congr. Ent.* p. 732.
- Williams, D.D. and H.B.N. Hynes. 1976. Stream habitat selection by aerially colonizing invertebrates. *Can. J. Zool.* 54: 685-693.
- Wolfe, L.S. and D.G. Peterson. 1959. Blackflies (Diptera:Simuliidae) of the forests of Quebec. *Can. J. Zool.* 37: 137-159.
- Wolfe, L.S. and D.G. Peterson. 1960. Diurnal behaviour and biting habits of blackflies (Diptera:Simuliidae) in the forests of Quebec. *Can. J. Zool.* 38: 489-497.
- Wotton, R.S. 1976. Evidence that blackfly larvae can feed on particles of colloidal size. *Nature, London* 261: 697.
- Wu, Y.F. 1931. A contribution to the biology of *Simulium* (Diptera). *Michigan Academy of Science, Arts and Letters* 13: 543-599.
- Zahar, A.R. 1951. The ecology and distribution of black-flies (Simuliidae) in Southeast Scotland. *J. Anim. Ecol.* 20: 33-61.

5.0. APPENDIX

Appendix A. Flume velocity data and mean velocity vectors
at selected coordinates about larvae

Two-dimensional profiles:

Velocity Profile #18

Flume velocity data:

No. of readings: 328

No. of readings placed on grid: 327

Mean thoracic position of larva (mm) (X,Y): 0.228, 0.154

Mean head position of larva (mm) (X,Y): 0.395, 0.210

Magnification factor¹: 38.54

Film speed (fps): 24

Strobe speed (fpm): 25,000

Mean velocity vectors at selected coordinates about larva:

Axes coordinates (cm)		Vector components (cm)			
Y-axis	X-axis	X	Y	Vel. (cm/sec)	No. of readings
0.65	-0.195	6.369	-0.272	7.969	4
	-0.065	4.504	-0.151	5.634	15
	0.065	2.336	0.657	3.032	1
	0.195	3.552	-0.410	4.470	10
	0.324	3.253	0.147	4.071	11
	0.454	3.496	0.423	4.401	12
	0.584	3.265	0.603	4.150	8
0.195	-0.195	8.199	-0.849	10.304	9
	-0.065	7.007	-0.153	8.760	6
	0.065	6.412	-0.152	8.018	11
	0.195	7.033	-0.398	8.805	10
	0.324	4.703	0.653	5.935	11
	0.454	4.728	0.289	5.921	11
	0.584	4.980	0.348	6.240	16

¹ Magnification factor for digitizing.

Profile #18, cont'd.

Axis coordinates (cm)		Vector components (cm)				No. of readings
Y-axis	X-axis	X	Y	Vel. (cm/sec)		
0.324	-0.195	5.796	-0.020	7.245	7	
	-0.065	7.110	-0.601	8.919	10	
	0.065	7.391	-1.361	9.394	10	
	0.195	8.469	-1.240	10.700	8	
	0.324	7.478	-0.188	9.351	9	
	0.454	6.396	-0.074	7.995	9	
	0.584	1.803	1.805	3.189	13	
	0.714	5.085	1.254	6.548	1	
0.454	-0.195	8.375	-0.409	10.481	7	
	-0.065	7.247	-0.431	9.075	8	
	0.065	7.886	-0.343	9.866	11	
	0.195	9.105	0.263	11.386	10	
	0.324	7.750	0.886	9.750	5	
	0.454	7.679	-0.272	9.605	11	
	0.584	9.360	-1.084	11.779	11	
	0.714	7.936	-2.698	10.478	1	
0.584	-0.195	8.564	0.350	10.714	3	
	-0.065	8.022	-0.012	10.028	8	
	0.065	8.759	-1.505	11.109	11	
	0.195	8.787	-0.623	11.013	11	
	0.324	8.964	-1.628	11.389	8	
	0.454	7.711	-0.033	9.639	11	
	0.584	7.663	0.529	9.601	7	
	0.714	11.301	-1.445	14.241	1	
0.714	0.195	8.212	0.203	10.267	1	

Velocity Profile #19

Flume velocity data:

No. of readings: 259
 No. of readings on grid: 257
 Mean thoracic position (mm) (X,Y): 0.181, 0.190
 Mean head position (mm) (X,Y): 0.237, 0.312
 Magnification factor: 40.00
 Film speed (fps): 24
 Strobe speed (fpm): 25,000

Axes coordinates (cm)		Velocity components (cm)			
Y-axis	X-axis		Y	Vel. (cm/sec)	No. of readings
0.063	-0.438	1.766	-0.012	2.208	1
	-0.313	1.016	-0.219	1.299	2
	0.063	2.154	0.081	2.694	4
0.188	-0.563	2.629	-0.054	3.288	3
	-0.438	1.938	0.317	2.458	13
	-0.313	1.554	0.721	2.141	9
	-0.188	2.680	-0.029	3.350	2
	-0.063	2.567	0.118	3.213	12
	0.063	2.838	-0.014	3.548	16
	0.188	3.585	-0.142	4.485	6
0.313	-0.563	3.675	-0.088	4.595	9
	-0.438	2.975	-0.089	3.720	11
	-0.313	2.993	-0.027	3.741	16
	-0.188	3.733	0.455	4.701	9
	-0.063	3.734	0.100	4.669	15
	0.063	3.604	-0.062	4.506	13
	0.188	3.620	0.033	4.526	8
0.438	-0.563	3.525	-0.076	4.408	5
	-0.438	4.201	-0.089	5.253	12
	-0.313	4.539	0.100	5.675	11
	-0.188	4.430	0.027	5.538	15
	-0.063	4.989	0.098	6.239	9
	0.063	4.314	0.038	5.393	9
	0.188	4.479	0.003	5.936	8

Profile #19, cont'd.

Axes coordinates (cm)		Vector components (cm)			
Y-axis	X-axis	X	Y	Vel. (cm/sec)	No. of readings
0.563	-0.563	5.087	0.242	6.366	4
	-0.438	4.570	0.037	5.723	5
	-0.313	5.497	0.041	6.873	5
	-0.188	4.699	0.220	5.880	10
	-0.063	4.552	0.194	5.696	7
	0.063	5.502	0.018	6.878	5
	0.188	3.621	0.127	4.530	3

Velocity Profile #20

Flume velocity data:

No. of readings: 134

No. of readings on grid: 134

Mean thoracic position (mm) (X,Y): 0.186, 0.095

Mean head position (mm) (X,Y): 0.299, 0.055

Magnification factor: 40.00

Film speed (fps): 12

Strobe speed (fpm): 25,000

Axes coordinates (cm)		Vector components (cm)			
Y-axis	X-axis	X	Y	Vel. (cm/sec)	No. of readings
0.063	-0.438	2.695	-0.110	2.967	1
	-0.188	2.651	0.037	2.916	1
	-0.063	4.641	0.199	5.111	2
	-0.563	4.881	-0.152	5.372	3
	-0.438	4.971	-0.622	5.511	2
	-0.313	4.577	-0.453	5.060	3
	-0.188	4.801	-0.299	5.291	9
	-0.063	5.639	0.131	6.205	2
	0.063	4.171	0.044	4.588	8
	0.188	3.107	0.167	3.423	1

Profile #20, cont'd.

Axes coordinates (cm)		Vector components (cm)			
Y-axis	X-axis	X	Y	Vel. (cm/sec)	No. of readings
0.313	-0.688	5.708	-0.685	6.323	1
	-0.563	5.815	-0.144	6.399	4
	-0.438	5.919	-0.116	6.512	12
	-0.313	5.314	-0.189	5.580	8
	-0.188	5.784	-0.187	6.366	6
	-0.063	5.969	-0.165	6.569	6
	0.063	6.335	-0.556	6.995	3
	0.188	5.496	0.405	6.062	2
	0.313	5.961	-0.392	6.571	1
0.438	-0.688	5.642	-0.397	6.221	2
	-0.563	5.158	-0.146	5.676	2
	-0.438	7.220	-0.481	7.960	5
	-0.313	7.583	-0.383	8.351	6
	-0.188	6.710	-0.450	7.398	10
	-0.063	6.797	-0.276	7.483	4
	0.063	6.824	-0.307	7.514	7
	0.188	5.395	-0.230	5.940	1
0.563	-0.563	8.034	0.322	8.845	2
	-0.313	7.642	0.213	8.410	3
	-0.188	7.120	-0.001	7.832	6
	-0.063	6.920	0.155	7.614	5
	0.063	7.638	-0.127	8.403	3
	0.188	8.150	0.026	8.965	1
0.688	-0.188	6.874	0.309	7.569	1
	-0.063	8.612	0.826	9.516	1

Velocity profile #21

Flume velocity data:

No. of readings: 289
 No. of readings on grid: 202
 Mean thoracic position (mm) (X,Y): 0.399, 0.082
 Mean head position (mm) (X,Y): 0.666, 0.122
 Magnification factor: 27.10
 Film speed (fps): 12
 Strobe speed (fpm): 25,000

Axes coordinates (cm)		Velocity components (cm)			
Y-axis	X-axis	X	Y	Vel. (cm/sec)	No. of readings
0.092	-1.015	3.320	-4.585	6.226	1
	-0.830	6.577	-1.042	7.325	3
	-0.646	6.080	1.041	6.785	22
	-0.461	5.364	0.351	5.914	38
	-0.277	5.370	0.172	5.910	28
	-0.092	4.879	1.193	5.525	30
	0.092	4.492	2.654	5.740	7
0.277	-0.830	10.658	-3.056	12.200	1
	-0.646	6.398	-1.286	7.179	7
	-0.461	5.403	-0.128	6.035	25
	-0.277	4.026	0.367	4.446	20
	-0.092	6.141	1.015	6.848	13
	0.092	4.567	1.883	5.434	3
0.461	-0.830	5.365	-4.268	7.542	1
	-0.646	6.559	-2.030	7.552	
	-0.461	4.371	-0.861	4.901	2
	-0.277	5.658	-1.119	6.344	2

Three-dimensional profiles:

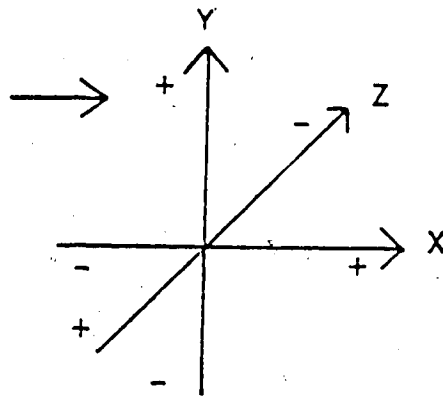

Fig. A.1. Axes of three dimensional velocity profiles. Negative and positive signs indicate position of larva and position and direction of vectors with respect to position of larval site of attachment (0,0,0). Arrow indicates direction of water flow.

Velocity Profile #22

Flume velocity data:

No. of readings: 97
 No. of readings placed on grid: 95
 Mean thoracic position (mm) (X,Y,Z): 3.41, 1.20, -0.57.
 Mean head position (mm) (X,Y,Z): 5.37, 2.05, -0.52.
 Actual image magnification factor: 22.37
 Prism image magnification: 18.16
 Mean angle of camera axis to tank bottom: 90.0
 Film speed (fps): 24
 Strobe speed (fpm): 25,000

Mean velocity vectors at selected coordinates about larva:

Axes coordinates (mm)			Vector components (mm)					No. of readings
Z-axis	Y-axis	X-axis	X	Y	Z	Vel. (mm/sec)		
-0.50	0.50	-3.50	443.41	9.04	-124.26	460.58	1	
		-2.50	434.52	45.40	-79.11	443.99	1	
		-1.50	397.85	54.85	-59.96	406.07	1	
	1.50	-1.50	376.02	33.63	-46.76	380.41	1	
		1.50	387.75	34.23	-47.67	392.63	1	
	2.50	-3.50	411.00	48.19	-67.15	419.23	1	
		-1.50	429.68	44.59	-94.28	442.19	2	
		0.50	415.22	53.62	-67.65	424.00	2	
		3.50	308.27	105.69	-39.78	328.30	1	
		4.50	323.14	-9.06	-4.11	323.29	1	
-1.50	0.50	-0.50	364.87	43.99	-42.52	369.96	1	
		-2.50	431.75	50.62	-107.45	447.79	2	
-1.50	1.50	-1.50	394.24	36.34	-39.38	397.87	1	
		0.50	369.76	81.39	-153.17	408.43	1	
		4.50	358.63	4.03	-61.08	363.82	1	
-1.50	2.50	-3.50	438.43	3.53	-91.48	447.89	1	
		-2.50	412.62	15.33	-69.47	418.71	2	
		-1.50	425.28	74.72	-108.31	445.17	1	
		-0.50	366.96	62.92	-26.43	373.25	1	
		0.50	389.09	43.42	-61.24	396.27	2	
		1.50	391.09	39.55	-81.01	401.35	1	
		2.50	360.06	30.74	-19.40	361.89	1	
	4.50	356.12	62.18	-32.32	362.95	1		

Profile #22, cont'd.

Z-axis	Y-axis	X-axis	X	Y	Z	Vel. (mm/sec)	No. of readings
-1.50	3.50	1.50	380	59.15	-61.02	389.39	1
		4.50	339.88	45.45	-44.10	345.73	2
		5.50	379.38	57.30	-47.14	386.57	1
-2.50	3.50	-1.50	462.15	29.07	-32.02	464.16	1
		-0.50	488.31	48.63	-63.53	494.82	1
		0.50	385.70	34.31	-51.11	390.58	1
		2.50	386.93	60.26	-50.15	394.79	5
		4.50	328.38	61.58	-59.86	339.42	3
		7.50	388.03	38.54	-45.89	392.63	1
-3.50	0.50	3.50	335.36	43.00	-40.41	340.51	1
-3.50	1.50	-2.50	377.96	-19.28	-86.35	388.18	1
		-1.50	445.66	36.44	-59.60	451.10	1
		0.50	437.00	31.13	-94.58	448.20	1
		3.50	369.19	137.38	-121.04	412.10	1
		4.50	343.44	14.43	-49.16	347.24	1
		6.50	319.01	26.36	-66.72	326.98	1
-3.50	2.50	-3.50	429.75	25.27	-142.88	453.58	1
		-2.50	301.85	2.34	-43.53	304.98	2
		1.50	368.02	42.78	-91.91	381.73	3
		2.50	406.67	31.78	-64.34	412.95	2
		5.50	368.75	57.08	-80.42	381.71	1
		6.50	328.99	31.48	-59.90	335.88	1
		7.50	292.87	38.20	-69.76	303.47	1
		8.50	355.19	22.08	-35.78	357.67	1
	3.50	-1.50	464.30	43.47	-67.22	471.15	1
		3.50	403.58	12.57	-27.03	404.68	1
		5.50	378.77	63.30	21.63	384.63	1
7.50		330.30	19.92	22.24	331.65	1	
-4.50	1.50	-0.50	293.76	26.69	-97.50	310.66	1
-4.50	2.50	-2.50	424.60	11.28	-66.88	429.98	2
		-1.50	424.04	-5.19	-107.29	437.43	1
		-0.50	455.74	18.67	-68.70	461.27	1
		5.50	350.19	14.17	-62.79	356.05	1
		6.50	382.66	34.29	-37.16	385.98	1
		7.50	128.58	56.53	-47.34	336.75	1
-4.50	3.50	4.50	345.87	-18.67	-29.78	347.65	1

Velocity Profile #23a

Flume velocity data:

No. of readings: 145
 No. of readings placed on grid: 128
 Mean thoracic position (mm) (X,Y,Z): 2.79, 0.75, 0.07
 Mean head position (mm) (X,Y,Z): 4.45, 1.07, -0.03
 Actual image magnification factor: 24.04
 Prism image magnification: 20.29
 Mean angle of camera axis to tank bottom: 96.3
 Film speed (fps): 12
 Strobe speed (fpm): 19,400

Axes coordinates (mm)			Vector components (mm)					No. of readings
Z-axis	Y-axis	X-axis	X	Y	Z	Vel. (mm/sec)		
-3.50	0.50	-4.50	104.90	-1.00	-5.60	105.06	1	
		4.50	143.30	9.82	-8.25	143.88	1	
		6.50	65.11	-2.76	2.10	65.20	1	
-3.50	1.50	-4.50	113.23	-8.55	-27.25	116.90	1	
		-3.50	119.51	8.95	-21.75	121.80	1	
		-2.50	135.19	1.20	-0.14	135.19	1	
		-1.50	151.67	18.18	-15.45	153.53	1	
	1.50	121.92	9.08	3.60	122.31	1		
-3.50	2.50	4.50	156.25	8.77	-29.82	159.32	1	
-3.50	3.50	6.50	125.77	33.04	-6.18	130.18	1	
-2.50	0.50	-1.50	119.91	10.19	-34.40	121.20	1	
		-0.50	136.57	-1.94	-0.80	136.59	1	
		0.50	70.25	-1.81	-2.29	70.31	1	
		1.50	73.07	3.13	-3.58	73.23	2	
		2.50	106.42	0.80	-11.38	107.03	2	
		3.50	154.83	0.24	-17.05	155.76	1	
		5.50	80.70	6.20	3.61	81.02	2	
6.50	51.80	0.47	5.00	52.05	3			
-2.50	1.50	-1.50	105.74	-5.37	-17.94	107.38	1	
		-0.50	146.62	-10.35	-33.12	150.67	1	
		1.50	116.04	2.62	9.09	116.42	2	
		6.50	99.95	6.89	-7.82	100.49	1	

Profile #23a, cont'd.

Z-axis	Y-axis	X-axis	X	Y	Z	Vel. (mm/sec)	No. of readings
-2.50	2.50	-1.50	184.84	5.60	-17.50	185.75	1
-2.50	3.50	-2.50	181.29	1.69	-32.58	384.20	1
		4.50	159.26	27.96	-14.46	153.92	1
-1.50	1.50	-3.50	144.92	4.43	-19.61	140.31	1
		-2.50	149.67	-7.54	-13.67	150.48	1
		0.50	129.74	10.55	-8.98	130.48	1
		1.50	99.92	0.50	-12.39	100.68	3
		2.50	117.91	6.30	-12.08	118.69	1
		4.50	119.58	-0.33	-5.79	119.72	2
		5.50	67.02	2.56	6.41	67.37	8
		6.50	42.03	0.97	7.78	42.76	4
		7.50	49.67	4.82	9.19	50.74	1
-1.50	1.50	9.50	138.98	6.41	-4.50	139.20	1
-1.50	2.50	-3.50	114.37	1.39	-7.54	114.62	1
		1.50	154.59	19.78	-22.32	157.44	1
		2.50	141.94	24.48	-16.79	145.01	1
		3.50	142.23	3.74	-35.77	146.71	1
		4.50	135.11	24.90	-12.54	137.96	1
		6.50	151.00	-0.03	-4.58	151.07	1
-1.50	3.50	-4.50	137.70	-4.11	-25.23	140.05	1
		-1.50	121.77	7.26	-19.96	123.61	1
		4.50	150.26	27.96	-14.46	153.52	1
-0.50	0.50	-1.50	117.55	6.14	-27.37	120.85	3
		-0.50	28.78	3.08	-16.15	33.14	1
		4.50	78.00	-1.99	-4.79	78.17	1
		6.50	39.43	2.25	15.45	42.43	1
-0.50	1.50	1.50	154.60	11.12	-20.45	156.34	2
		2.50	127.93	-3.85	-14.16	128.77	1
		3.50	181.39	30.53	-31.87	186.68	1
		6.50	74.22	1.01	-23.11	77.74	1
		8.50	127.73	3.92	-2.07	127.80	1
-0.50	2.50	-3.50	125.29	-8.73	-17.86	126.85	2
		0.50	146.87	16.43	-12.70	148.33	2
		1.50	186.38	13.22	-9.33	187.08	1
		2.50	155.27	14.28	-8.33	156.15	3
		3.50	49.70	1.37	0.70	49.72	1
		4.50	142.89	11.26	-19.86	144.71	2

cont'd.

Profile #23a, cont'd.

Z-axis	Y-axis	X-axis	X	Y	Z	Vel. (mm/sec)	No. of readings
-0.50	3.50	-4.50	111.16	-3.44	-13.23	112.00	1
		-2.50	137.40	9.45	-22.15	139.49	1
		2.50	137.80	15.43	-16.33	139.63	2
-0.50	4.50	4.50	175.26	26.95	-3.33	177.35	1
		5.50	157.79	10.68	-9.22	158.42	1
		7.50	142.69	14.76	-7.36	143.64	1
		8.50	135.20	5.07	-5.37	135.40	1
0.50	0.50	2.50	157.10	18.15	-27.68	160.55	1
0.50	1.50	-1.50	169.12	16.06	-31.98	172.86	1
		-0.50	149.32	4.52	-20.53	150.80	1
		1.50	56.68	3.12	-2.67	54.83	1
		2.50	152.15	3.50	-4.53	152.48	2
		3.50	150.55	14.51	-5.22	151.34	1
		5.50	58.43	6.21	-0.72	58.77	2
0.50	2.50	-0.50	163.54	13.91	-23.26	165.77	3
		4.50	60.51	23.10	-72.60	97.34	1
		5.50	148.04	12.39	-11.10	148.97	2
0.50	3.50	2.50	100.25	5.71	-16.34	101.78	1
		4.50	148.87	4.25	-18.49	150.07	2
		5.50	158.83	18.04	-11.71	160.28	1
		7.50	142.32	30.27	-24.55	147.56	1
0.50	4.50	2.50	159.58	8.82	-20.25	161.10	1
		3.50	152.81	-18.58	9.78	154.24	1
		6.50	162.79	11.60	-0.63	163.20	1
1.50	1.50	-1.50	163.33	26.96	-1.67	165.55	1
		-0.50	171.15	15.46	-1.53	171.86	1
		-0.50	121.84	2.60	-23.57	124.13	1
		1.50	151.11	15.57	-5.11	151.99	1
		3.50	148.40	17.08	-22.63	151.09	1
1.50	2.50	2.50	188.54	19.78	-10.75	189.87	1
		4.50	151.55	2.78	1.65	151.59	1
		5.50	130.12	14.06	22.73	132.85	1
1.50	3.50	1.50	134.77	21.26	-32.43	140.24	1
		3.50	131.47	4.35	-9.38	131.88	1

Velocity Profile #23b

Flume velocity data:

No. of readings: 145

No. of readings placed on grid: 141

Mean thoracic position (mm) (X,Y,Z): 2.79, 0.75, 0.07

Mean head position (mm) (X,Y,Z): 4.45, 1.07, -0.03

Actual image magnification factor: 24.04

Prism image magnification: 20.29

Mean angle of camera axis to tank bottom: 96.3

Film speed (fps): 12

Strobe speed (fpm): 19,400

Axes coordinates (mm)			Vector components (mm)					No. of readings
Z-axis	Y-axis	X-axis	X	Y	Z	Vel. (mm/sec)		
1.00	-1.00	-1.00	28.75	2.11	-16.76	33.34	1	
1.00	1.00	-1.00	167.87	19.49	-11.73	169.40	3	
		1.00	119.74	6.45	-12.97	120.61	4	
		3.00	152.07	11.35	-14.92	153.22	5	
		5.00	58.43	6.21	-0.72	58.77	2	
1.00	3.00	-1.00	163.54	13.91	-23.26	165.77	3	
		1.00	134.77	21.26	-32.43	140.24	1	
		3.00	140.10	9.95	-12.15	140.98	3	
		5.00	136.85	11.41	-14.90	138.14	8	
		7.00	142.32	30.27	-24.55	147.56	1	
1.00	5.00	3.00	156.19	-4.88	-5.24	156.36	2	
		7.00	162.79	11.60	-0.63	163.20	1	
-1.00	-1.00	-3.00	80.53	-1.36	-8.02	80.94	2	
		-1.00	77.09	5.64	-13.63	78.49	2	
		1.00	49.76	4.33	-0.17	49.95	3	
		5.00	36.99	0.92	10.05	38.34	2	
-1.00	1.00	-3.00	144.92	4.43	-19.61	146.31	1	
		-1.00	106.22	2.79	-22.38	108.59	5	
		1.00	123.12	5.72	-14.51	124.10	6	
		3.00	142.41	11.00	-19.37	144.14	3	
			77.57	1.62	3.17	77.65	11	
			47.35	1.71	4.67	47.61	7	
			133.35	5.17	-3.29	133.49	2	

Profile #23b, cont'd.

Z-axis	Y-axis	X-axis	X	Y	Z	Vel. (mm/sec)	No. of readings
-1.00	3.00	-5.00	124.43	-3.77	-19.23	125.96	2
		-3.00	125.58	-1.66	-16.35	126.65	4
		-1.00	121.77	7.26	-19.96	123.61	1
		1.00	156.00	14.68	-14.39	157.35	5
		3.00	125.28	9.76	-11.90	126.22	7
		5.00	141.13	17.72	-16.58	143.20	6
		7.00	151.00	-0.03	-4.58	151.07	1
-1.00	5.00	5.00	166.52	18.82	-6.28	167.70	2
		7.00	142.69	14.76	-7.38	143.64	1
		9.00	135.20	5.07	-5.37	135.40	1
-3.00	-1.00	-1.00	43.99	2.78	-9.92	45.18	1
		1.00	46.89	0.99	0.52	46.90	2
-3.00	1.00	-5.00	109.07	-4.78	-16.68	110.44	2
		-3.00	127.35	5.07	-10.94	127.92	2
		-1.00	132.10	2.14	-16.34	133.13	5
		1.00	95.07	3.13	-5.21	95.26	6
		3.00	122.56	0.62	-13.27	123.28	3
		5.00	101.57	7.41	-0.35	101.84	3
		7.00	64.09	1.11	1.86	64.13	5
-3.00	3.00	-3.00	181.29	1.69	-32.58	184.20	1
		-1.00	184.84	5.60	-17.50	185.75	1
		5.00	156.25	8.77	-29.82	159.32	1
		7.00	125.77	33.04	-6.18	130.18	1

Appendix B. Calculation of mean concentration of particles, $[p]$,
to which larvae were exposed

The area under the curve of the plot of particle/ml against time represents the mean concentration of particles, $[p]$, to which larvae are exposed. An estimate of this concentration is the \bar{Y} of $[p]$ plotted against time (fig. A.1). Since

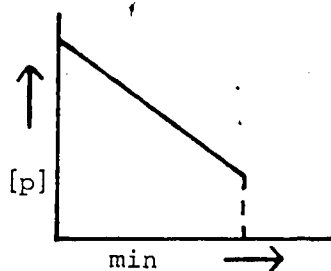

$Y = a + bX$ where Y is $[p]$,
 a is the Y intercept, b is the
slope, and X is time, then

$$\bar{Y} = a + \frac{bX}{2}$$

Fig. B.1. $[p]$ plot against time.

In 'doubled' experiments where:

- 1 refers to the curve based on the first type of particle added, and
- 2 refers to the curve based on the second type of particle added,
- 3 refers to the curve based on both types of particles present during the 2nd period (fig. A.2).

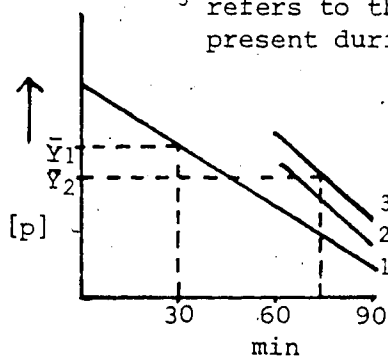

\bar{Y}_1 = estimate of mean $[p]$ for the 1st
time period (t_1), (e.g. 60 min),

\bar{Y}_2 = estimate of mean $[p]$ for the 2nd
time period (t_2), (e.g. 30 min, and
is based on curve 3.

Fig. B.2. $[p]$ plot against time, 'doubled' experiment.

cont'd

Appendix B, cont'd.

Estimate for the longer (e.g. 90 min) feeding period:

$$\bar{Y}_3 = \frac{(\bar{Y}_1 \times t_1) + (\bar{Y}_2 \times t_2)}{t_1 + t_2}$$

Estimate for the shorter period = \bar{Y}_2

Appendix C. Estimates of mean concentration of particles
for each experiment

Expt.	Regression of [p] against time				[P]	[P]	Weight particle added ³ (mgm)	
	L	Y int.	slope	F no.	\bar{Y}	estimate calculated ¹		estimate (approximate ²)
1a		11.90	-0.1942	38.52 **	6.08	12.83	12.64	1.0g
1b		87.35	-0.8135	600.62***	26.34	26.34	26.07	1.0r
2	L	1.2478	-0.0081	43.15 *	1.1262	13.73	13.23	1.0g
3		43.29	-0.5423	166.53 **	35.15	35.15	34.46	1.0r
4a	L	1.5425	-0.0029	9.28 *	1.4567	31.25	28.71	1.0r
4b		72.66	-0.4822	12.04 †	36.50	36.50	29.60	1.0g
5a	L	1.4163	-0.0108	13.77 †	1.0839	10.02	7.80	1.0r
5b	L	1.9778	-0.0164	8.96 †	0.7463	5.79	5.32	1.0g
6	L	1.6555	-0.0186	424.49 **	1.3761	23.77	22.44	1.0r
7	L	1.4816	-0.0271	540.79 **	1.0753	11.89	11.02	2.0g
8a	L	1.8297	-0.0105	6.69 †	1.6731	53.10	46.52	2.0r
8b		69.87	-0.2398	0.83	59.08	59.08	55.07	2.0g
9a	L	1.6782	-0.0045	6.47 †	1.5513	75.16	63.82	2.0g
9b		141.16	-0.5871	0.55	114.74	114.74	104.89	2.0r
10a	L	1.3509	-0.0140	35.71 **	0.9298	6.88	8.20	2.0r
10b		8.11	-0.0598	2.76	3.63	3.63	3.60	2.0g
11a	L	1.3299	-0.0111	42.29 *	1.1634	10.69	10.84	0.5r
11b	L	1.4129	-0.0078	9.07 †	0.9443	8.80	8.85	0.5g
12a	L	1.2623	-0.0159	163.46 **	1.1245	7.02	7.15	0.5r
12b	L	1.3461	-0.0124	52.86 *	0.6021	4.00	3.91	0.5g
13a	L	1.3721	-0.0048	8.32	1.2998	19.88	19.08	0.5r
13b	L	1.6040	-0.0051	188.20 **	1.2977	19.85	18.98	0.5g
14a	L	0.6098	-0.0198	16.34 *	0.3128	23.34	20.23	4.0g
14b	L	1.8250	-0.0039	1.01	1.6496	44.63	45.33	4.0r
15a	L	2.4720	-0.0062	17.52 *	2.1944	156.43	144.95	4.0r
15b	L	2.3270	-0.0082	69.14 **	2.2041	158.22	151.70	4.0g

L = logarithmic transformation applied.

Y int. = Y intercept.

¹ = calculated as in Appendix B.

² = area under curve of plot of [p] (raw data) with time (included for comparison with calcul. [p] estimate).

³ = g = green particles (diameter of 30 μ - 40 μ)
r = red particles (diameter of 20 μ - 30 μ)

† = significant at level of P = 0.1.

*, **, *** = as in text

$$F = \frac{\text{explained sum of squares}}{\text{unexplained sum of squares}} = \frac{\sum \hat{y}^2}{\sum d^2_{Y.X}}$$

Appendix D. Numbers of larvae of *Simulium vittatum* in each class
and total numbers of larvae examined in each experiment

Expt.	Larval Class				Total numbers	
	Small	Medium	Large	Large P.	Examined	In flume ¹
1	322	410	63	229	1094	3000
2	98	254	43	52	447	450
3	110	341	19	29	500	520
4	66	327	55	53	501	520
5	97	379	37	45	558	980
6	12	250	37	58	357	360
7	43	344	44	38	469	530
8	38	394	84	43	559	680
9	5	363	81	37	486	510
10	12	442	66	16	536	770
11	76	439	85	20	620	700
12	69	417	83	11	581	620
13	114	303	65	37	519	830
14	76	344	84	23	527	1600
15	69	290	96	57	512	1500

¹ Rounded off to nearest 10.

Appendix E. Parasitism of larvae of *Simulium vittatum*¹

Table I. Large parasitized larvae

Expt.	Nematodes ²				Proto.	Multiple Para.		Total para.	Percent para. by nematodes	Percent para. by microsp.
	s	w	g	Sum		Proto.+ N.	>1 N.			
1	11	84	120	215	8	3	3	229	59.39	2.21
2	3	19	25	47	4	1		52	49.47	4.21
3	3	6	15	24	4		1	29	50.00	8.53
4		12	28	40	7	1	5	53	40.00	7.00
5		14	21	35	3	2	5	45	42.68	3.66
6	1	32	19	52	3	1	2	58	54.77	3.16
7	1	19	15	35	2		1	38	43.75	2.50
8	3	18	18	39	4		1	44	30.71	3.15
9	4	16	11	31	6			37	26.27	5.08
10	1	9	3	13	3			16	15.85	3.66
11		7	9	16	3			19	14.95	2.80
12		5	4	9	2			11	6.12	1.36
13	3	17	7	27	5	1	4	37	26.42	4.90
14	2	10	5	17	2		3	22	17.00	2.00
15	5	28	13	46	9		2	57	31.29	6.12
Sum	37	296	313	646	65	9	27	747		
				27						
				673						

Percentage parasitized with nematodes: 91.13%
 Percentage parasitized with protozoans: 11.11%
 Percentage large larvae parasitized: 44.37%

Table II. Medium parasitized larvae

Expt.	Nematodes ²				Proto.	Multiple Para.		Total para.	Percent para. by nematodes	Percent para. by microsp.
	s	w	g	Sum		Proto.+ N.	>1 N.			
1	8	13	11	32	2	1		35	7.16	0.04
2	6	7	2	15	3			18	5.51	0.01
3	3	2	1	6	3			9	1.21	0.85
4		2		2	3			5	0.60	0.90
5	2	5	2	9			2	11	2.31	-
6		4	1	5	1		6	12	1.91	0.38
7	1	1	1	3	1		2	6	0.86	0.29
8	4	2	1	7	2	1		10	2.30	0.66
9	1			1				1	0.27	-
10										-
11		2		2	3			5	0.56	0.84
12				1	1			1	0.33	-
13	3	1	1	5	3			8	1.61	0.97
14	5	5	2	12	2		1	15	3.51	0.58
15	8	7	2	17	3			21	5.33	0.94
Sum	41	51	25	117	26	2	11	157		
				11						
				130						

Percentage parasitized with nematodes: 82.80%
 Percentage parasitized with protozoans: 36.94%
 Percentage medium larvae parasitized: 2.70%
 Percentage total population examined parasitized: 10.96%

¹Collected from a tributary of the Sturgeon River, nr. St. Albert, Alberta, in September and November, 1973.

²s = small, w = white, and g = green nematodes

Appendix F. Numbers of larvae of *Simulium vittatum* in each class
with mean (arcsine) percentage gut filled.

The results of one experiment are presented on each of the following 26 pages. Larval class is shown above each histogram, followed by the number of the experiment. N = number of larvae in each class; hatched bar = number of unfed larvae (0% gut filled); the number above each hatched bar is the number of unfed larvae.

Small discrepancies in number of larvae of any class between parts a and b of doubled experiments are because some larvae were damaged during examination, and had to be discarded.

SMALL 1A
N=322

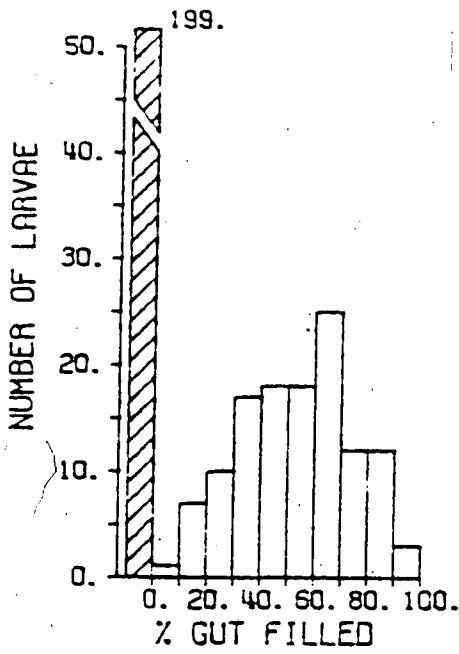

MEDIUM 1A
N=410

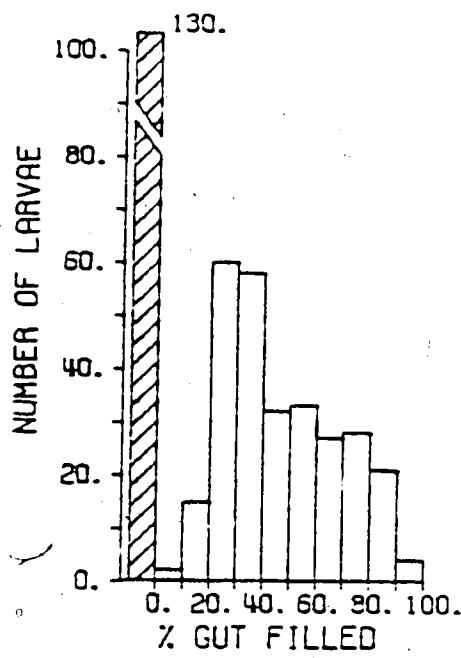

LARGE 1A
N= 63

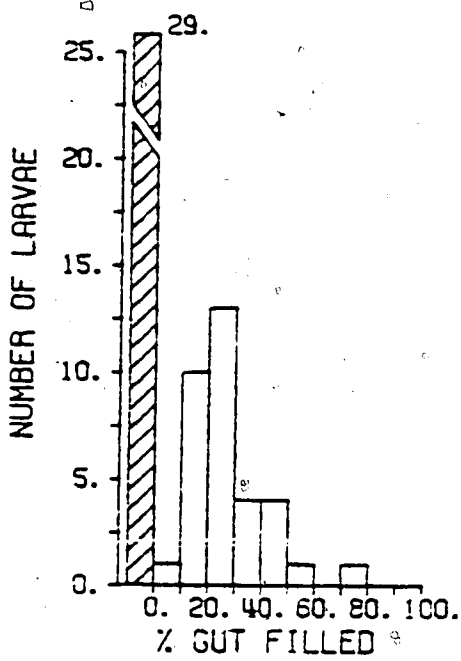

LARGE P. 1A
N=229

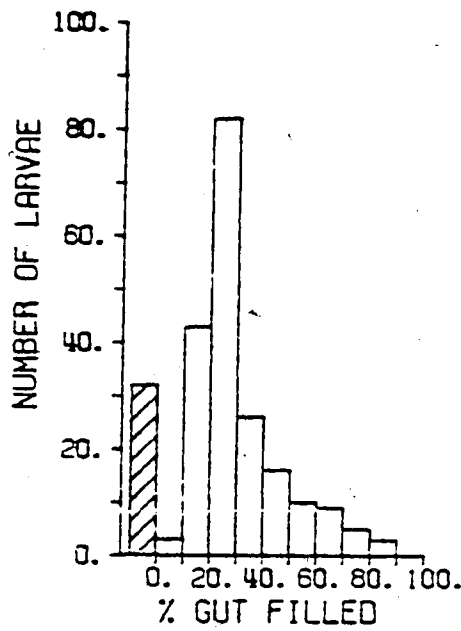

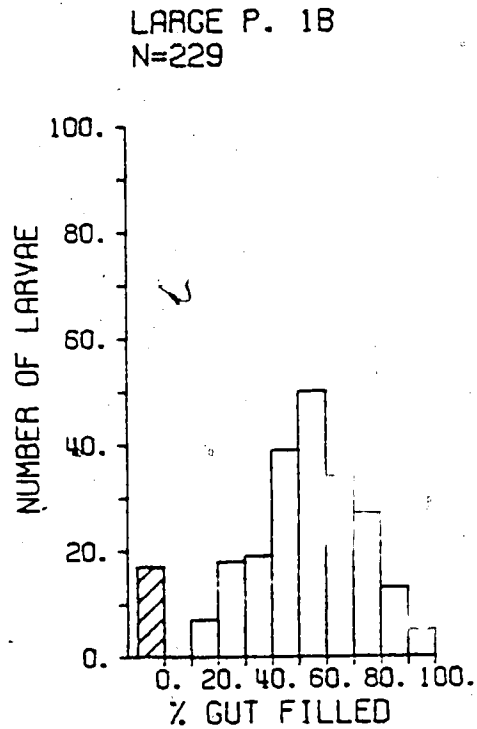
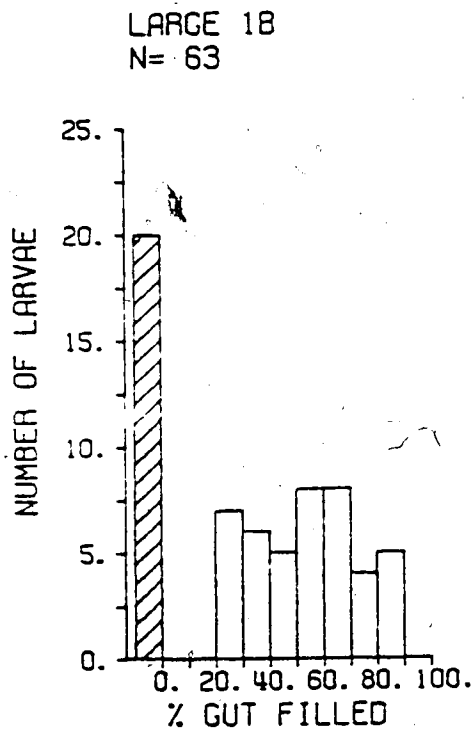
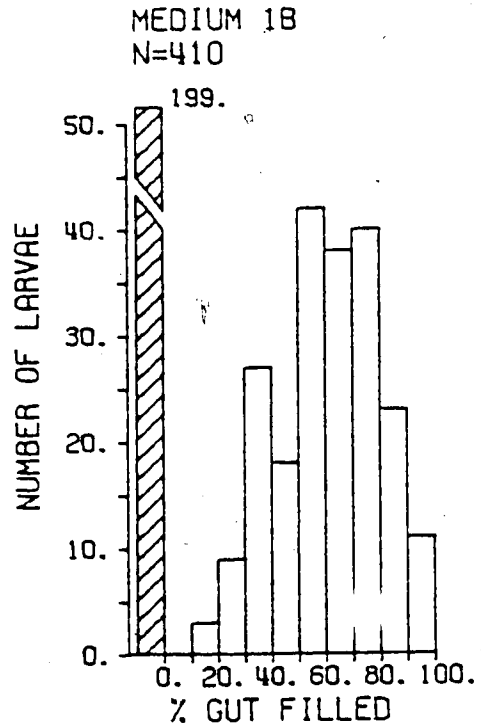
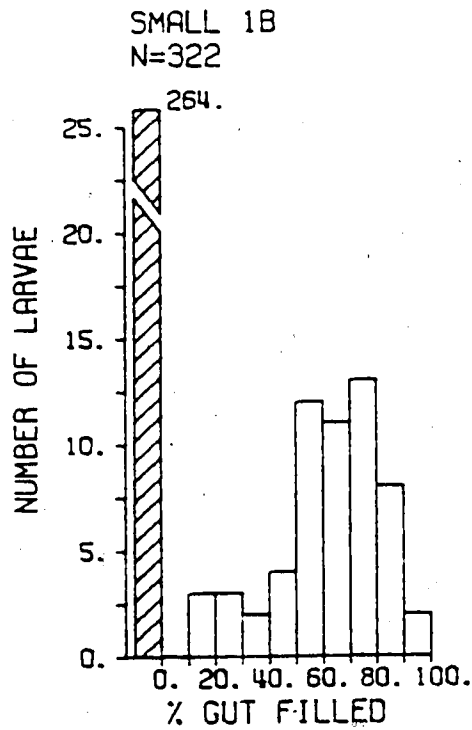

Appendix F, cont'd.

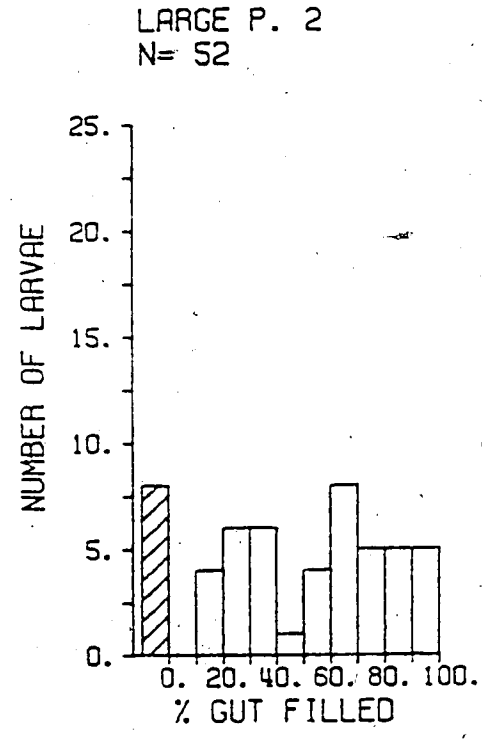
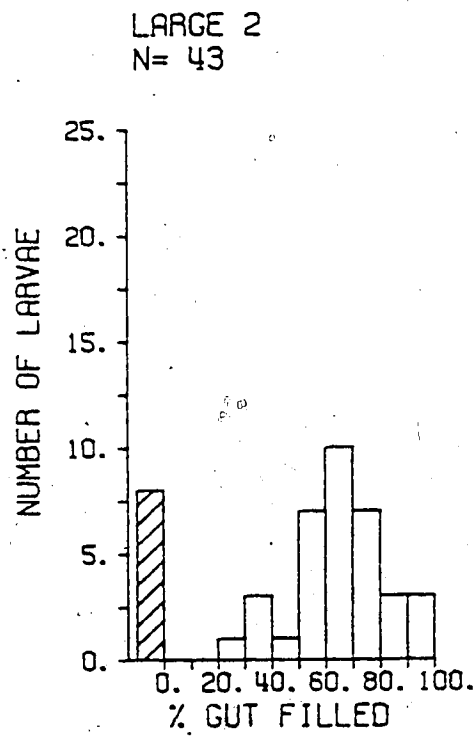
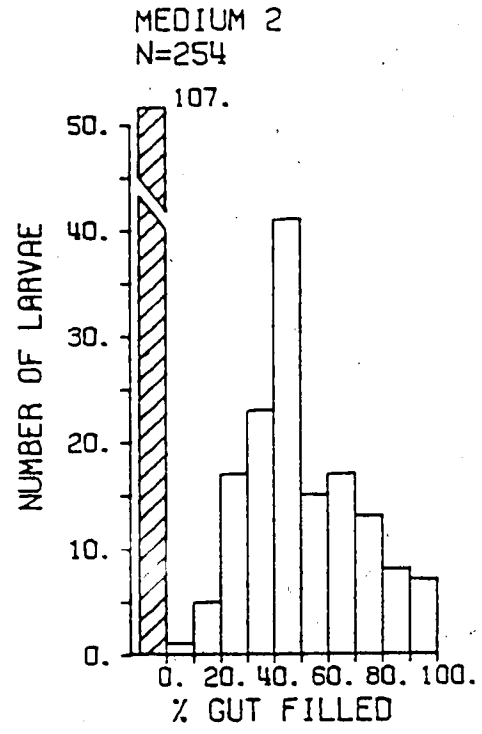
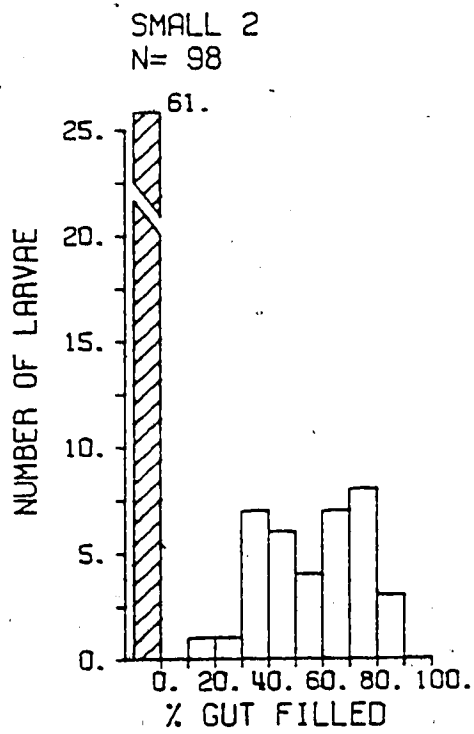

cont'd.

Appendix F, cont'd.

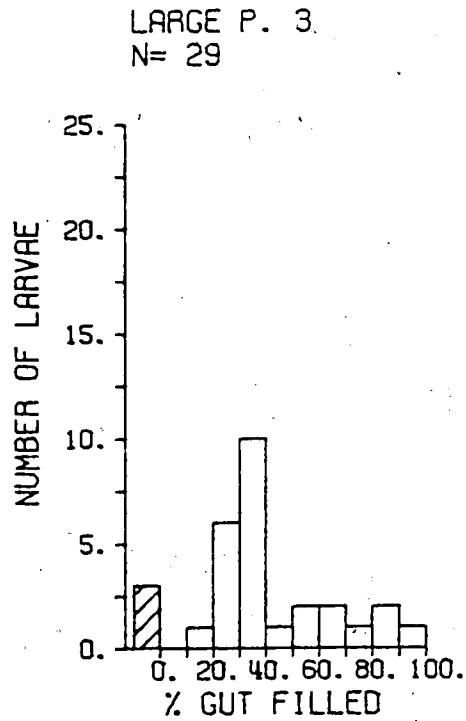
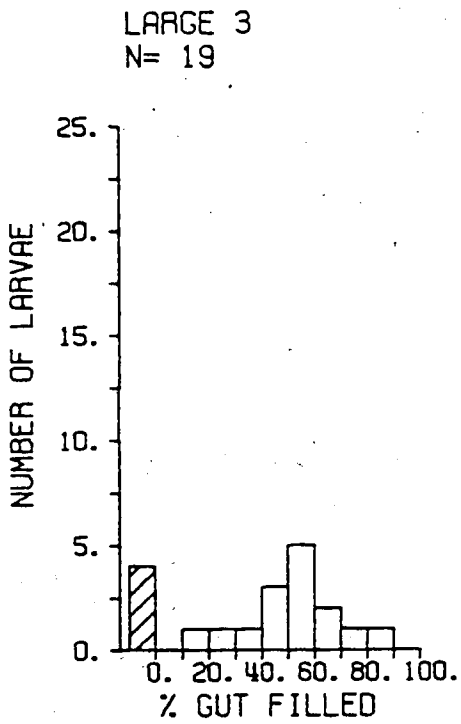
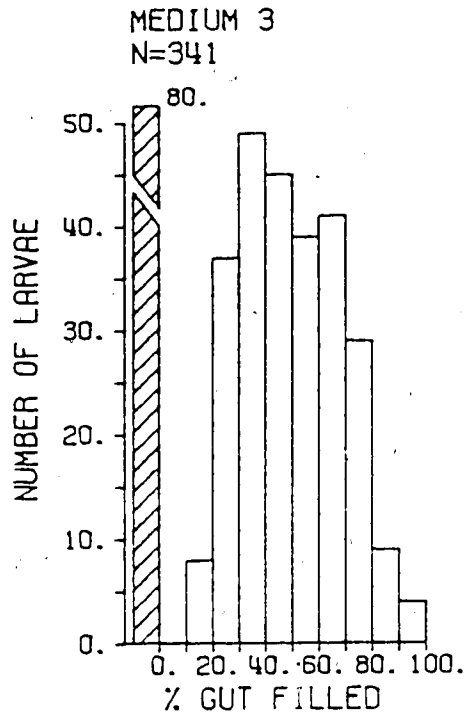
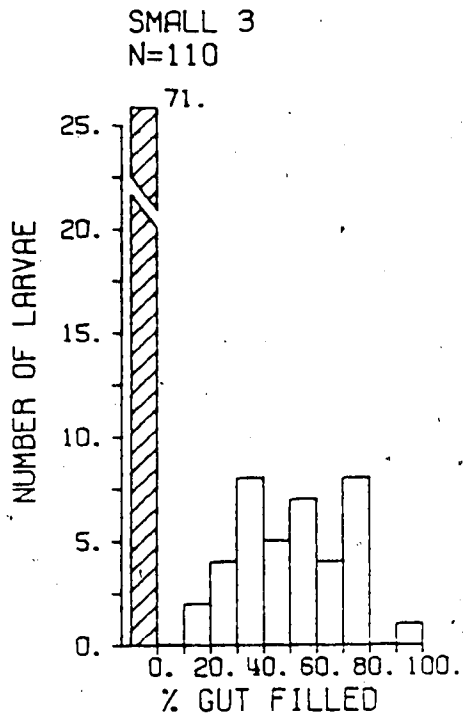

cont'd.

Appendix F, cont'd.

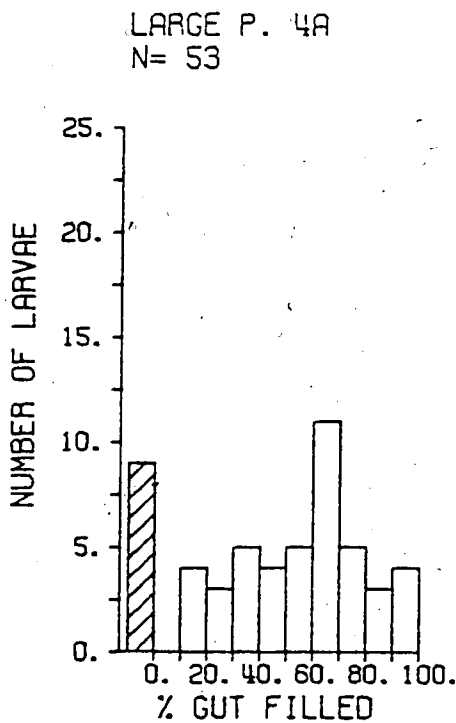
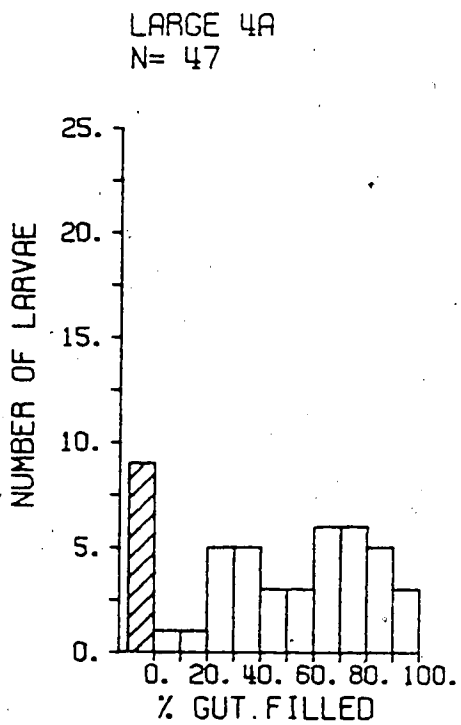
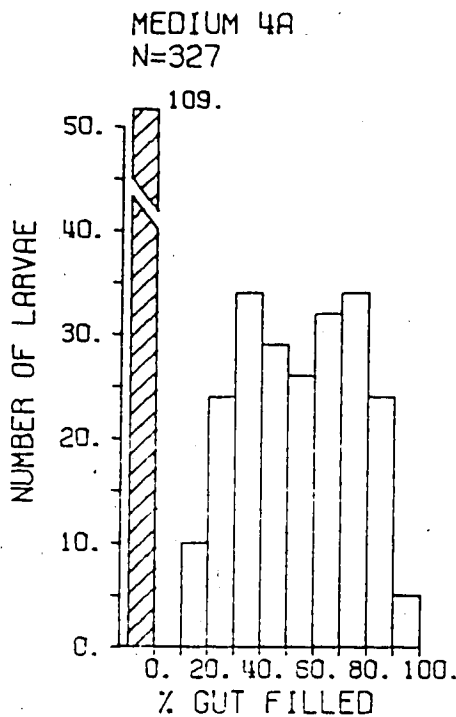
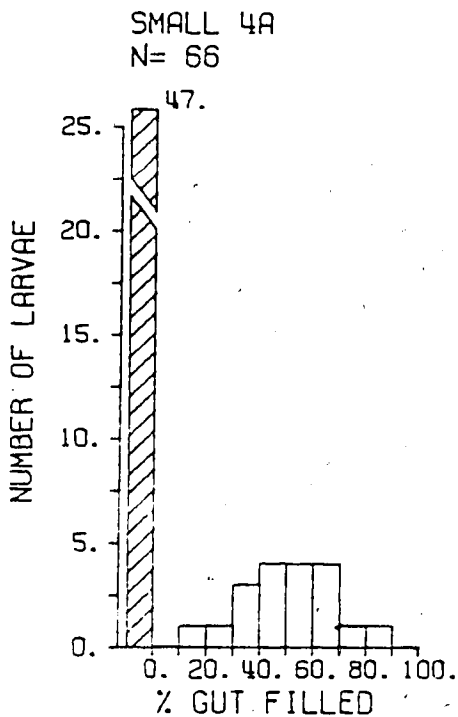

cont'd.

Appendix F, cont'd.

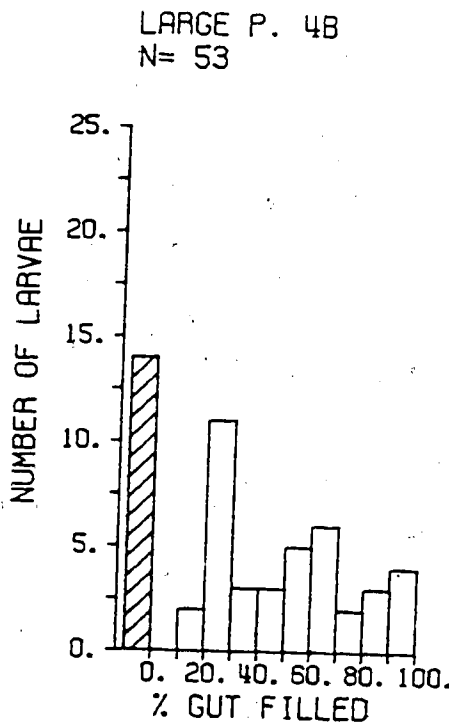
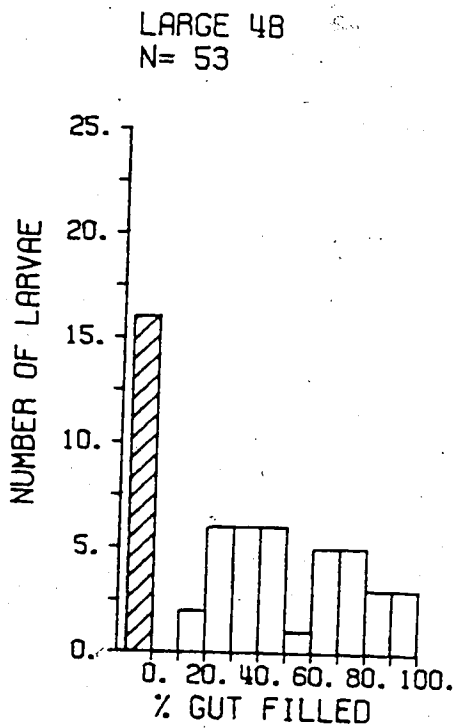
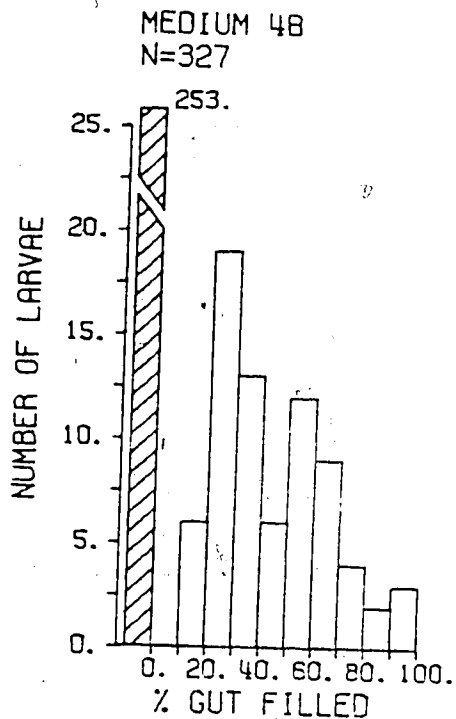
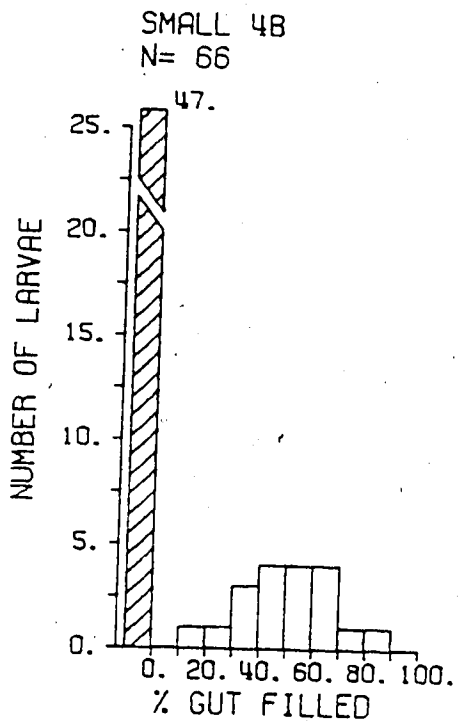

cont'd.

Appendix F, cont'd.

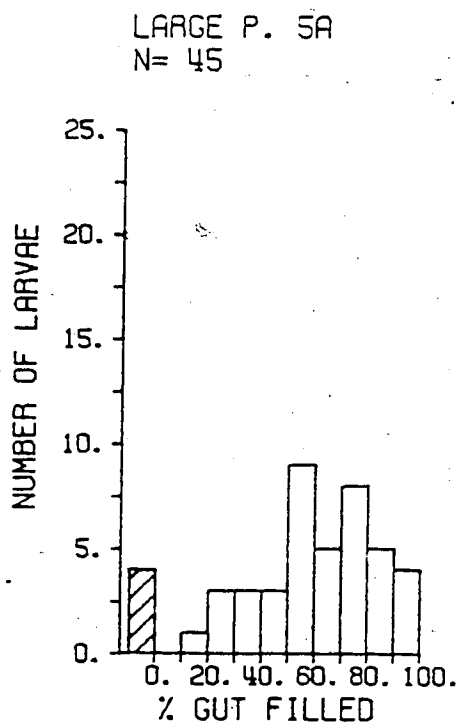
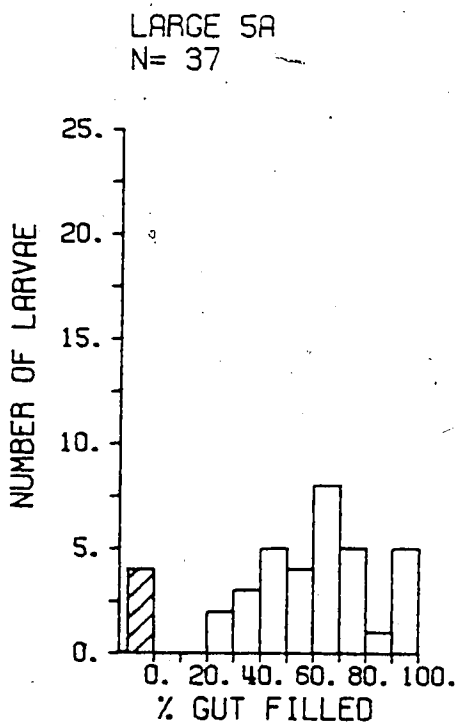
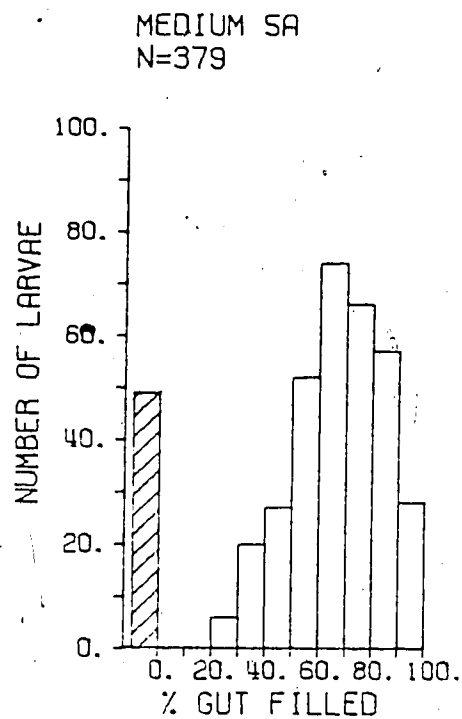
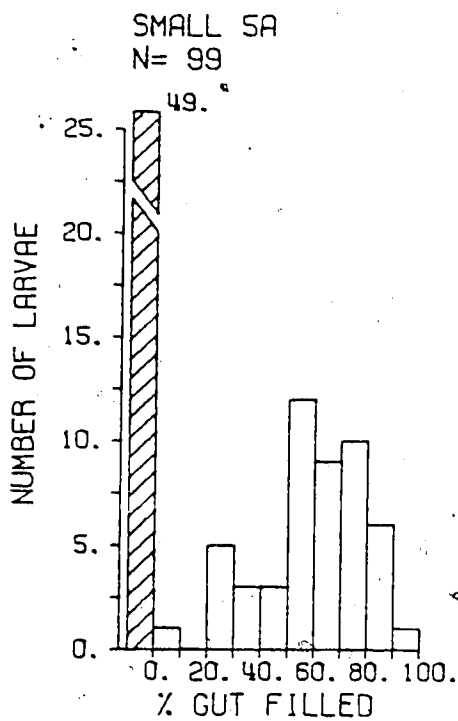

cont'd.

Appendix F, cont'd.

SMALL SB
N= 97

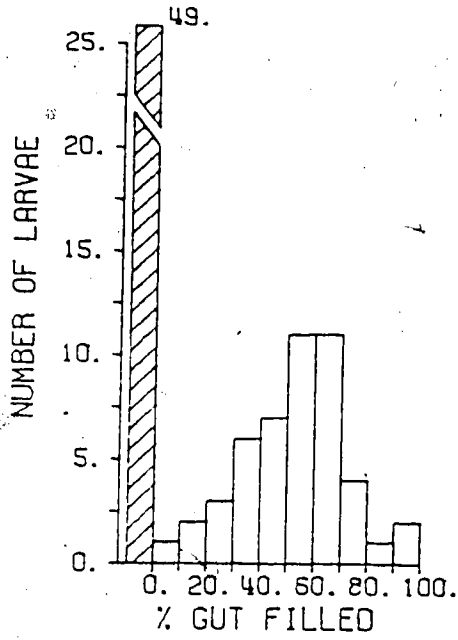

MEDIUM SB
N=379

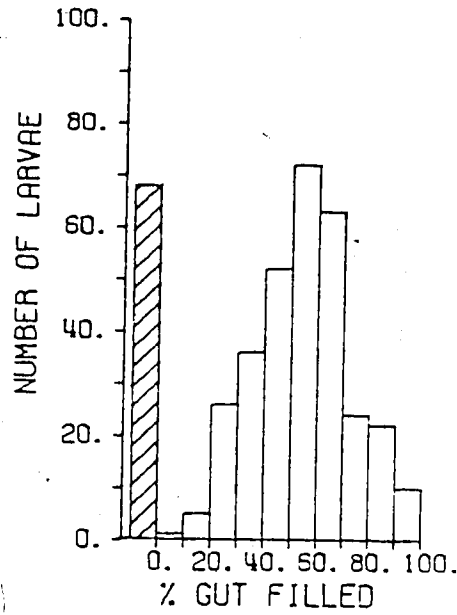

LARGE SB
N= 37

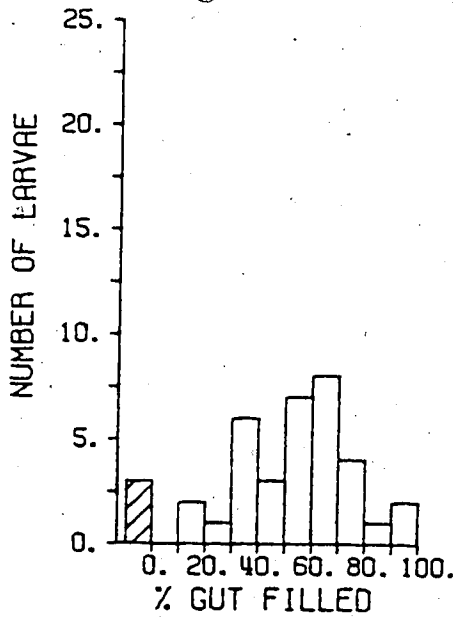

LARGE P. SB
N= 45

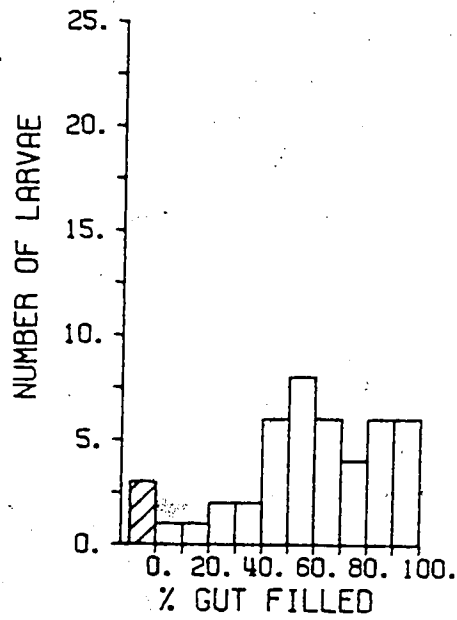

cont'd.

Appendix F, cont'd.

MEDIUM 6
N=250

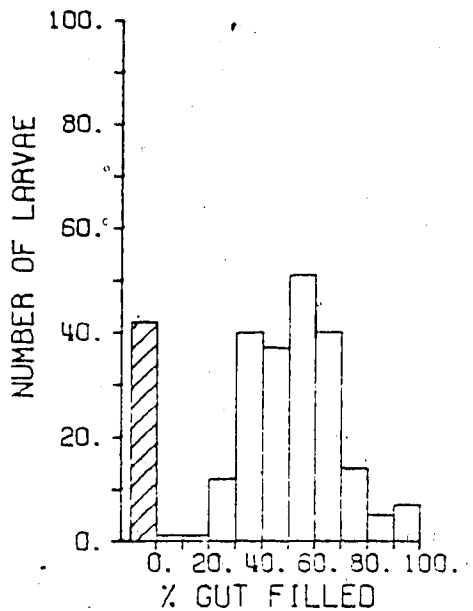

LARGE 6
N= 37

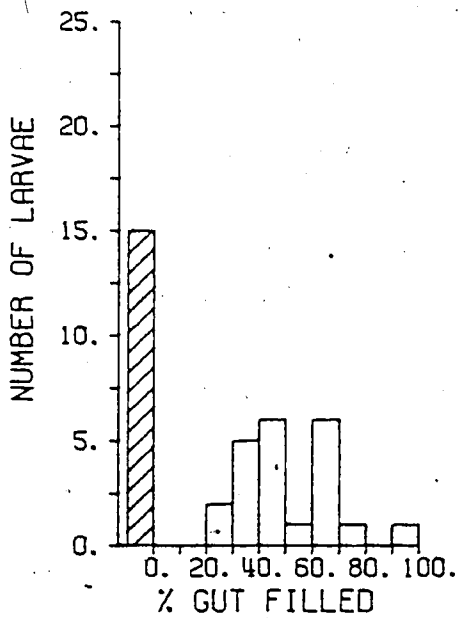

LARGE P. 6
N= 58

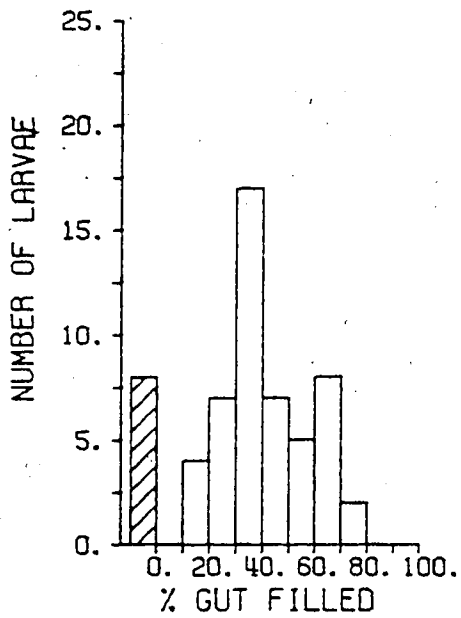

cont'd.

Appendix F, cont'd.

MEDIUM 7
N=344

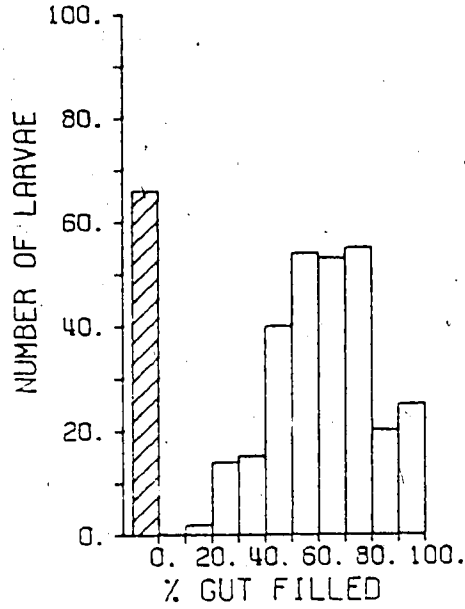

LARGE 7
N= 42

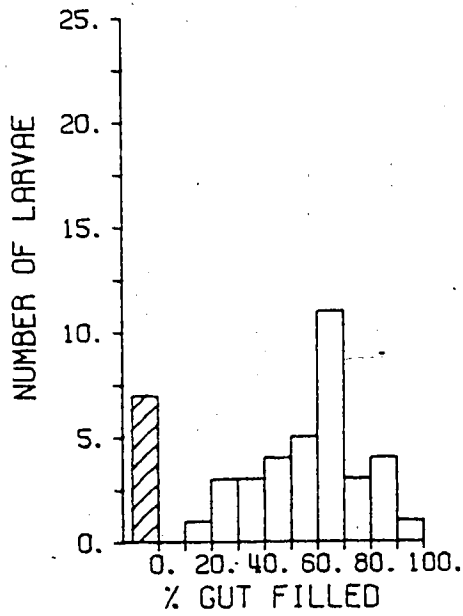

LARGE P. 7
N= 38

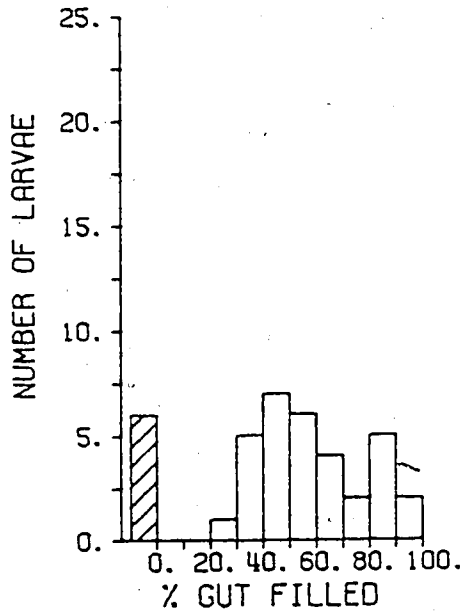

cont'd.

Appendix F, cont'd.

SMALL 8A
N= 40

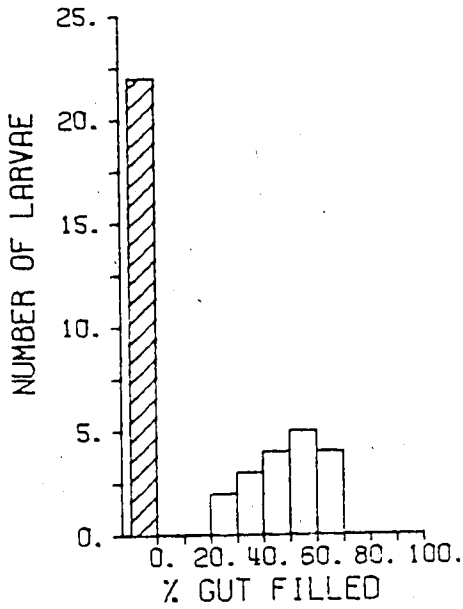

MEDIUM 8A
N=394

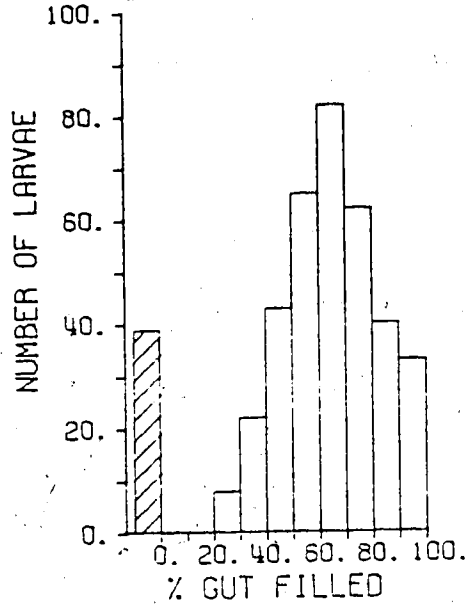

LARGE 8A
N= 84

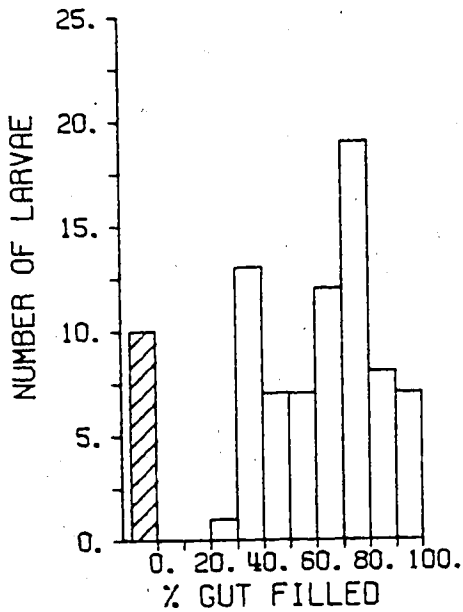

LARGE P. 8A
N= 44

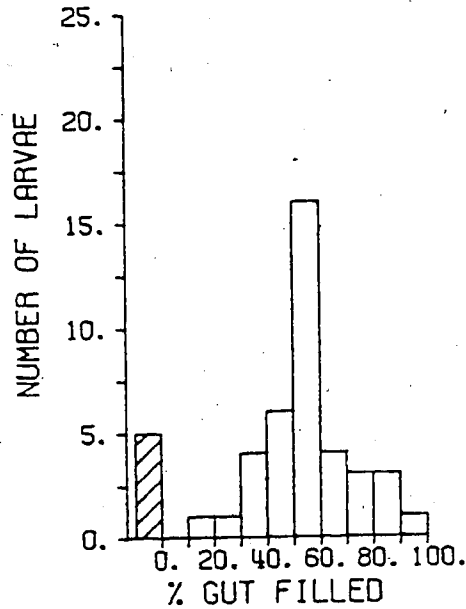

cont'd.

Appendix F, cont'd

SMALL 88
N= 38

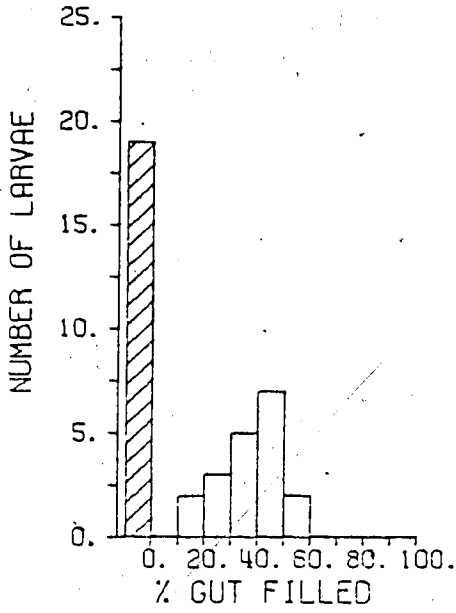

MEDIUM 88
N=393

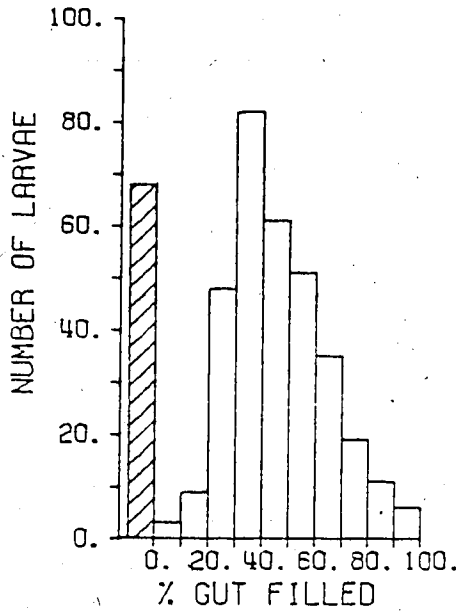

LARGE 88
N= 84

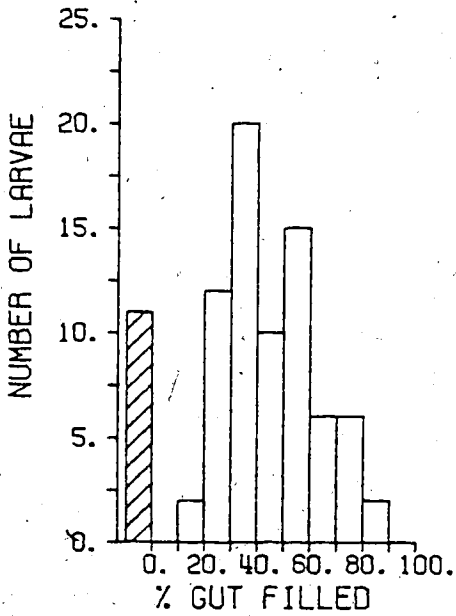

LARGE P. 88
N= 43

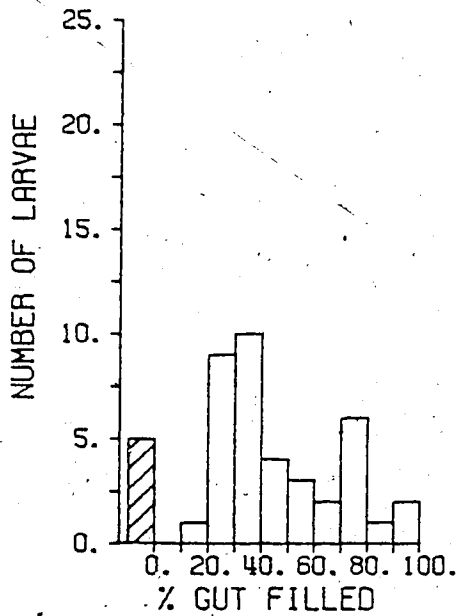

cont'd.

Appendix F, cont'd.

MEDIUM 9A
N=363

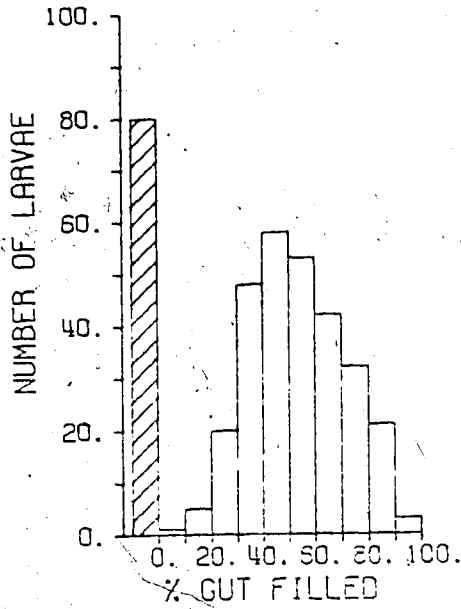

LARGE 9A
N= 80

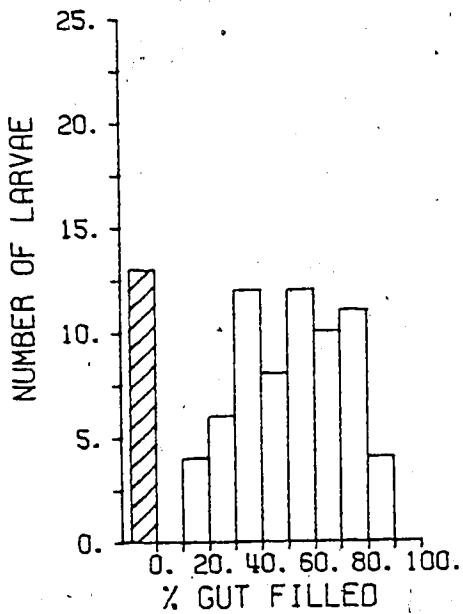

LARGE P. 9A
N= 37

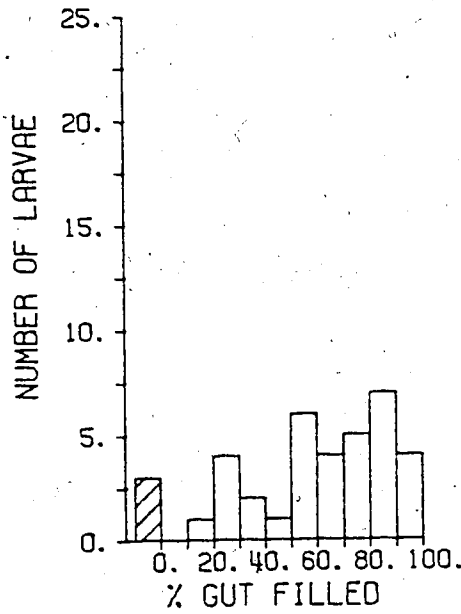

cont'd.

Appendix F, cont'd.

MEDIUM 9B
N=369

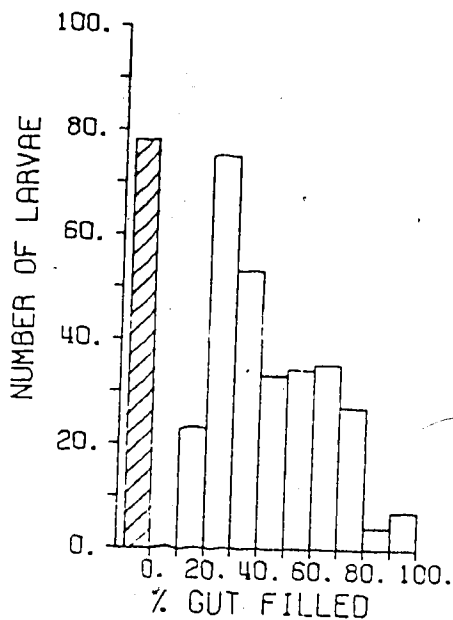

LARGE 9B
N= 81

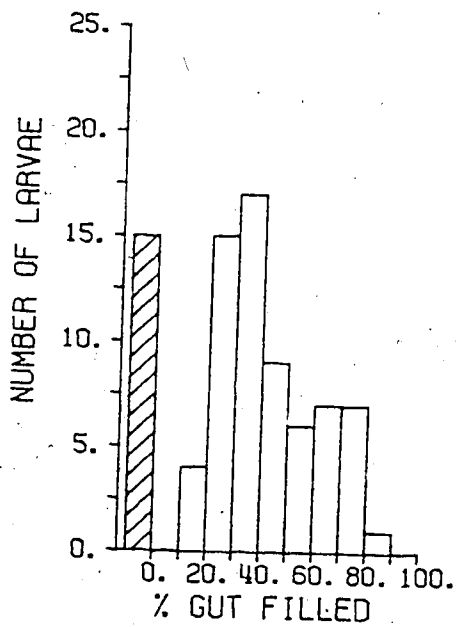

LARGE P. 9B
N= 37

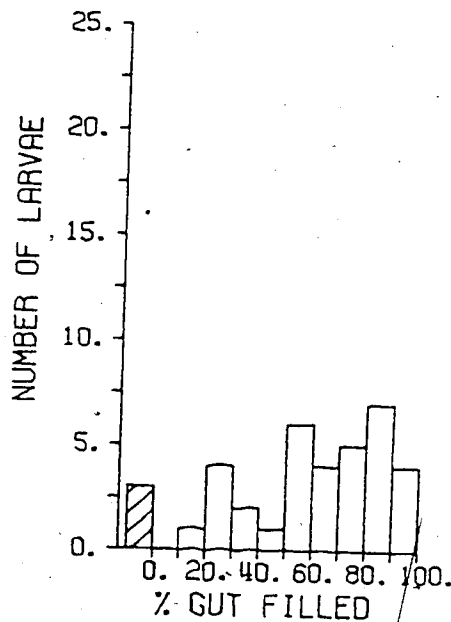

cont'd.

Appendix F, cont'd.

MEDIUM 10A
N=442

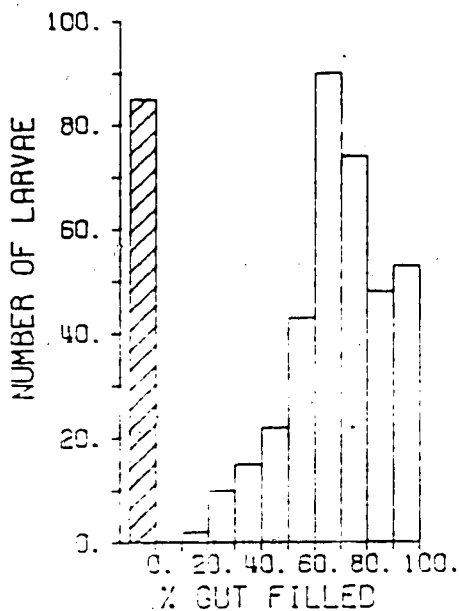

LARGE 10A
N= 66

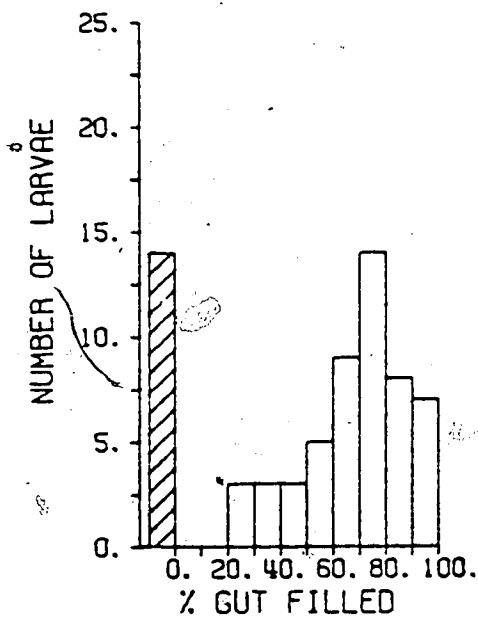

cont'd.

Appendix F, cont'd.

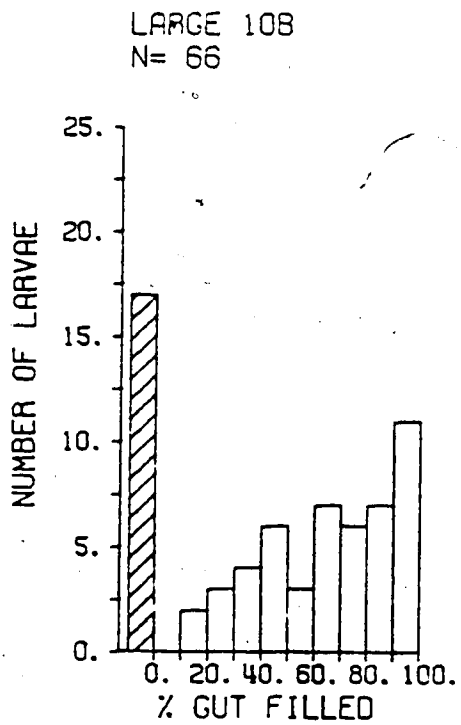
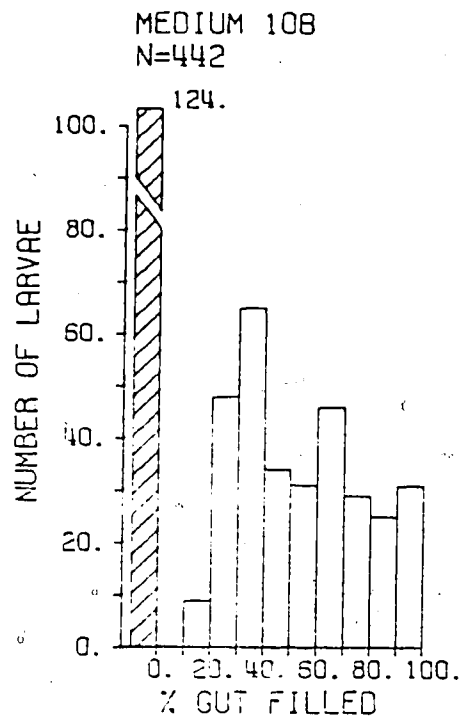

cont'd.

Appendix F, cont'd.

MEDIUM 11A
N=438

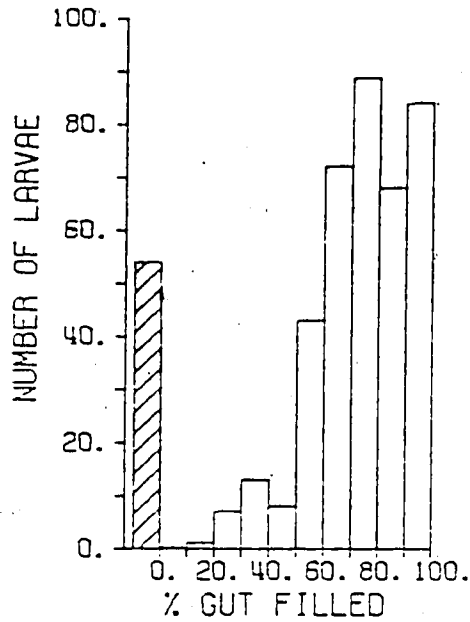

LARGE 11A
N= 83

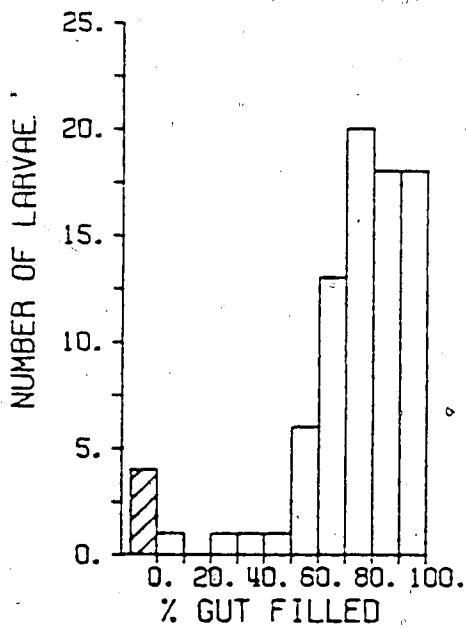

LARGE P. 11A
N= 20

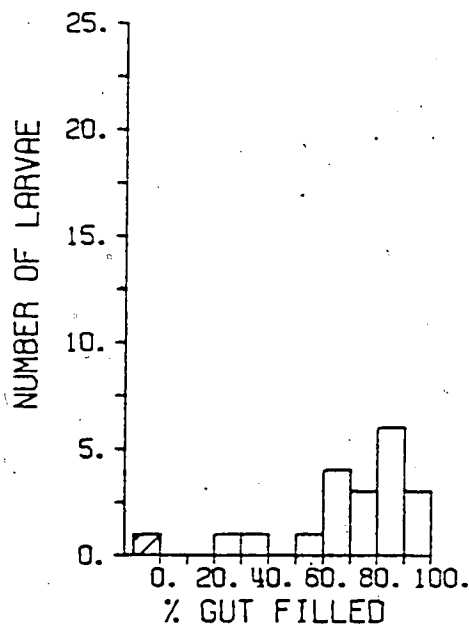

Appendix F, cont'd.

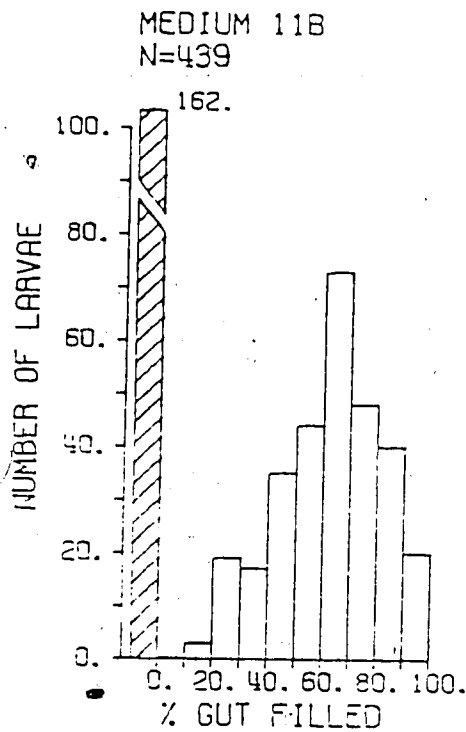

LARGE 11B
N= 85

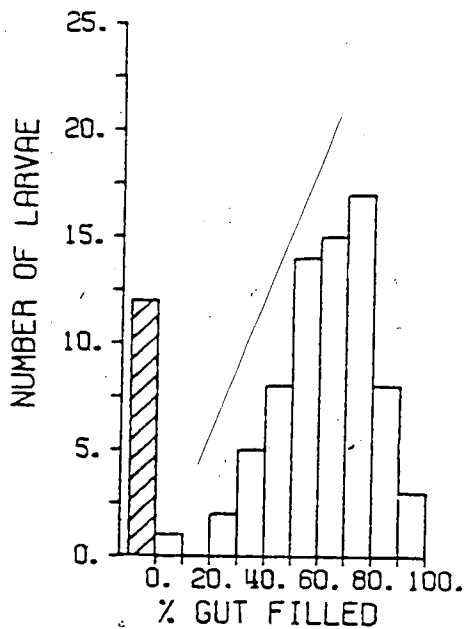

LARGE P. 11B
N= 19

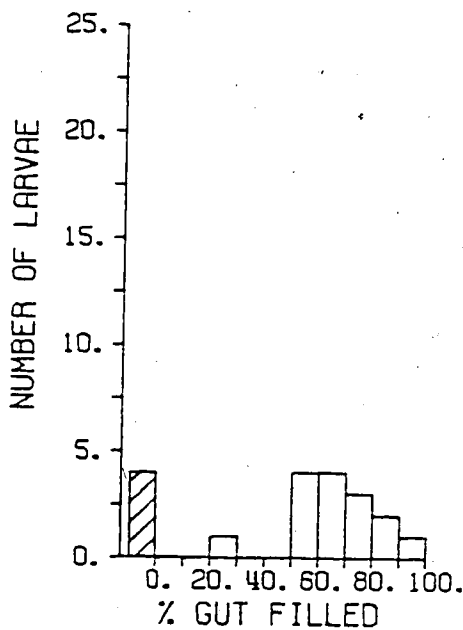

cont'd.

Appendix F, cont'd.

MEDIUM 12A
N=415

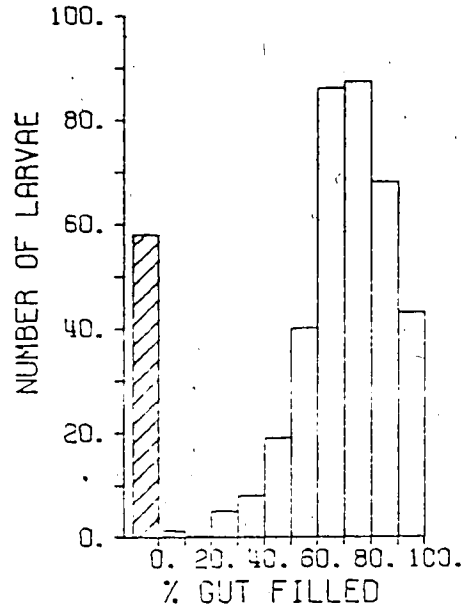

LARGE 12A
N= 84

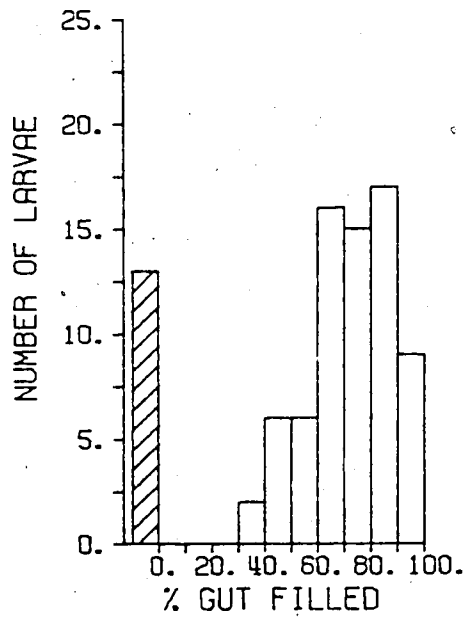

cont'd.

Appendix F, cont'd.

MEDIUM 12B
N=417

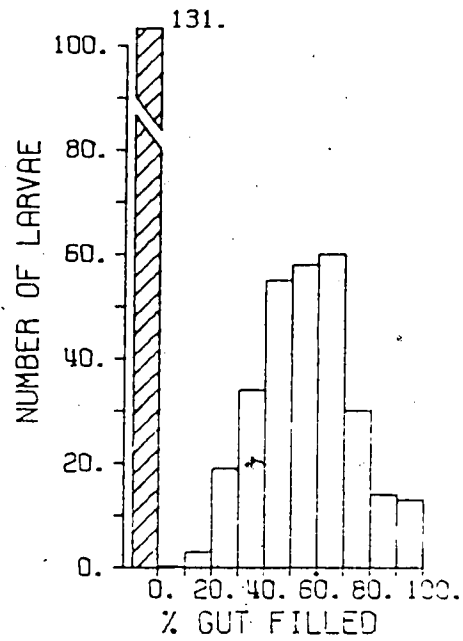

LARGE 12B
N= 83

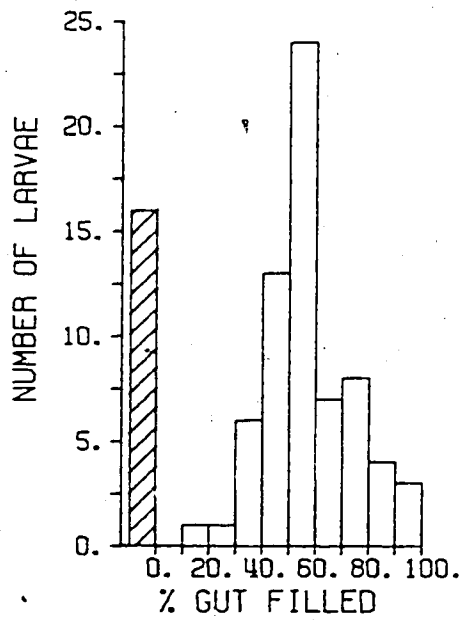

cont'd.

Appendix F, cont'd.

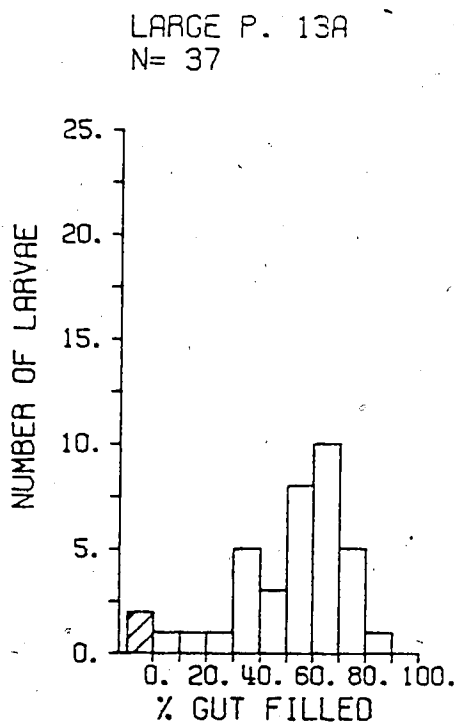
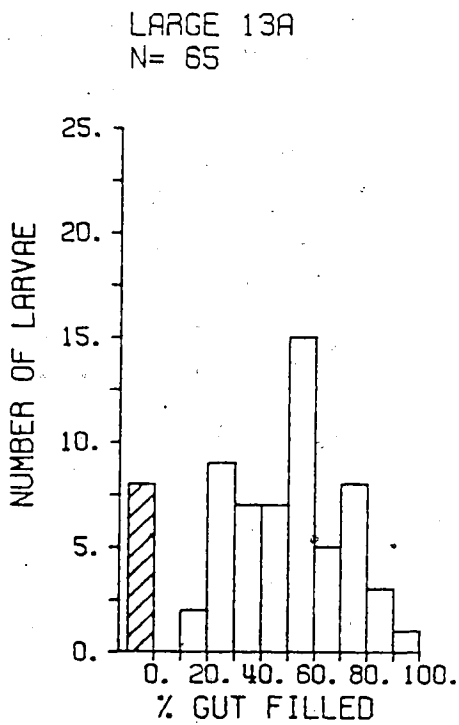
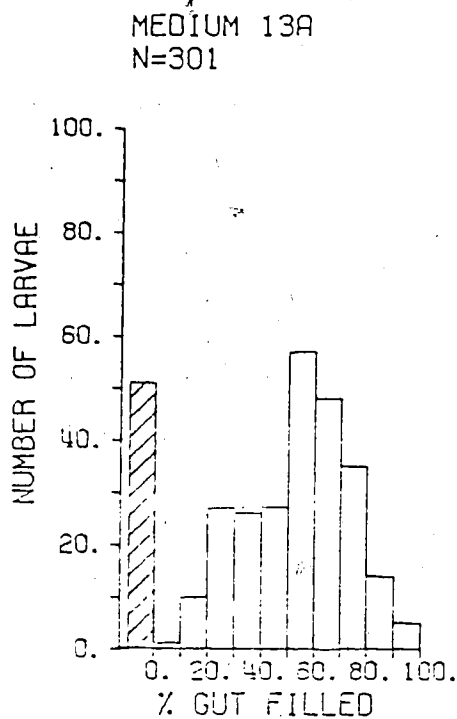
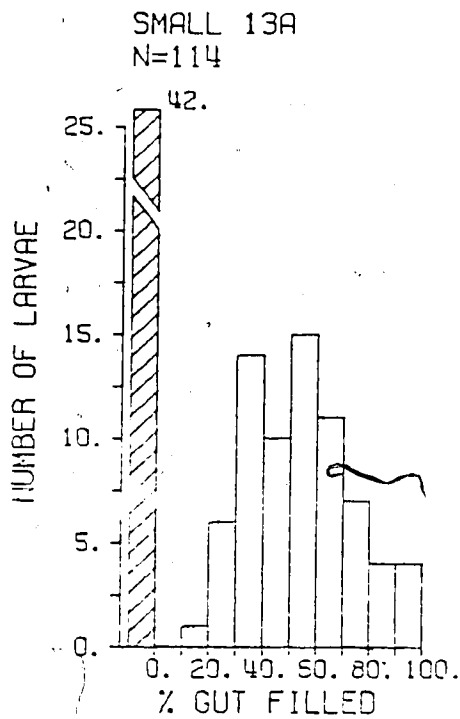

cont'd.

Appendix F, cont'd.

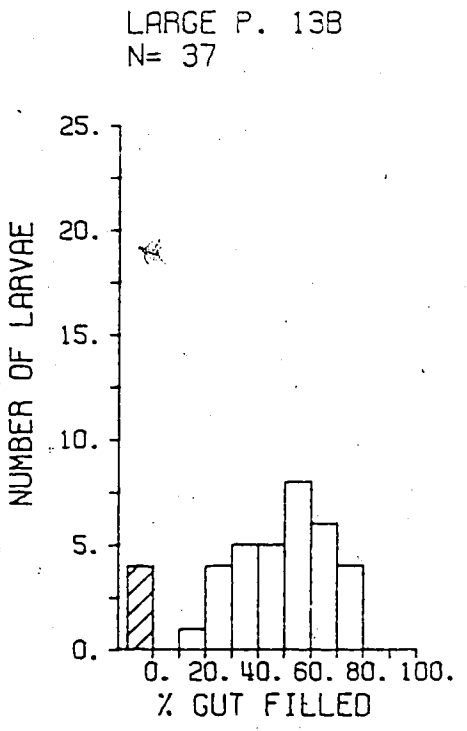
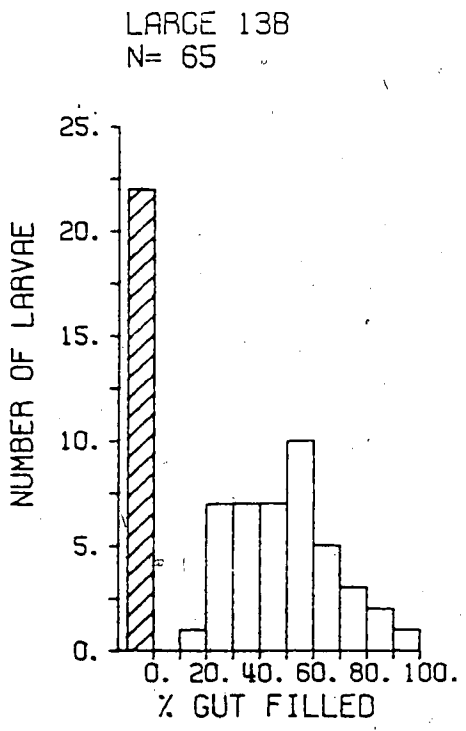
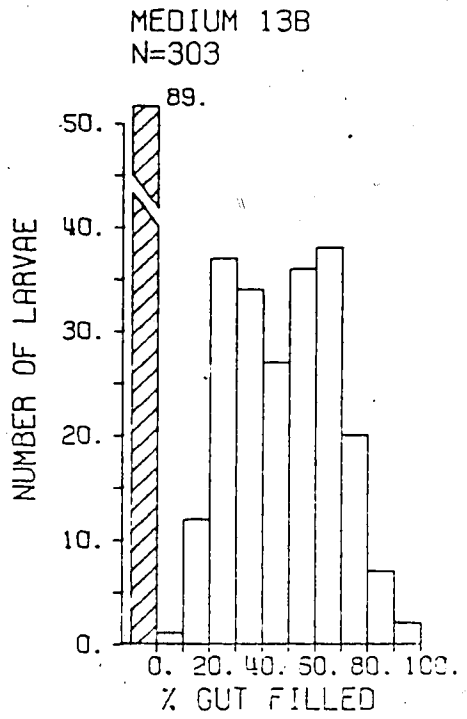
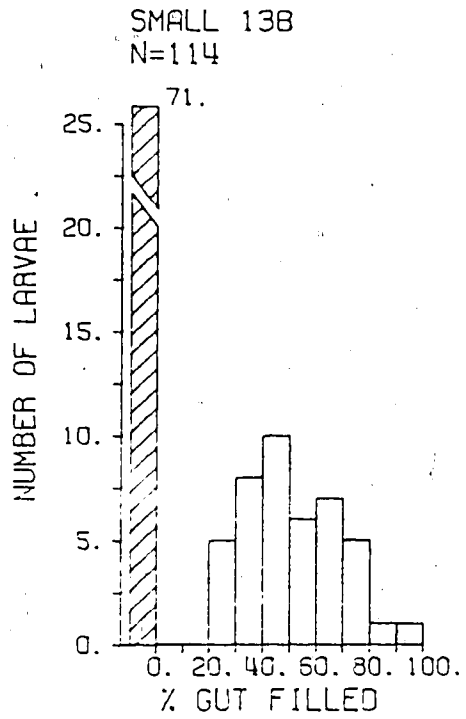

cont'd.

Appendix F, cont'd.

SMALL 14A
N= 76

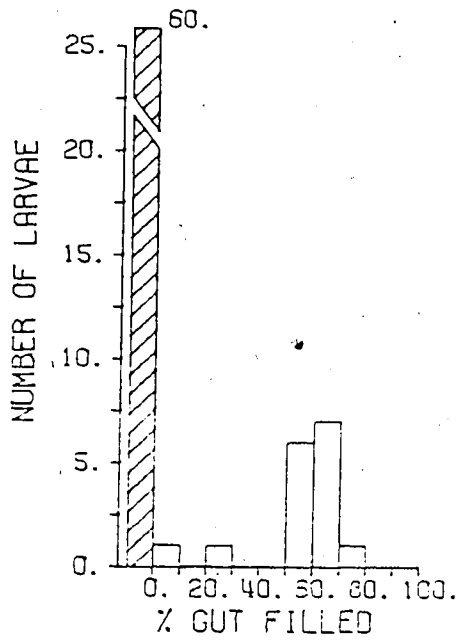

MEDIUM 14A
N=344

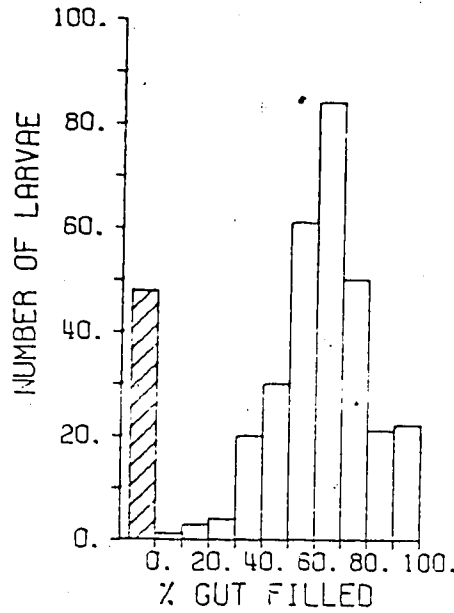

LARGE 14A
N= 84

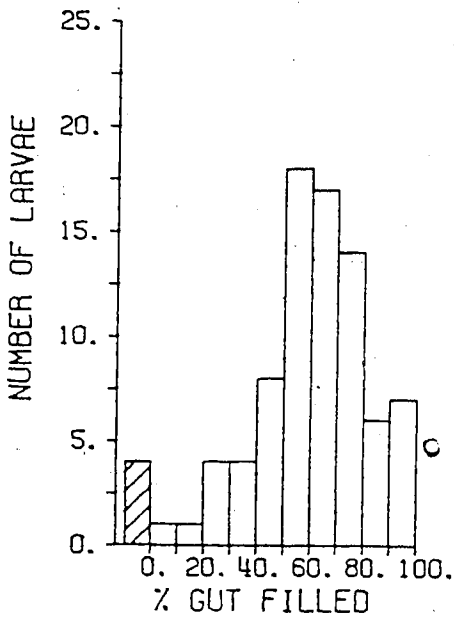

LARGE P. 14A
N= 23

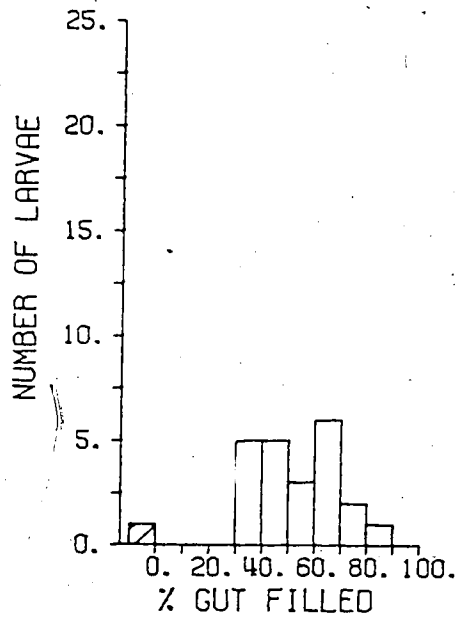

cont'd.

Appendix F, cont'd.

SMALL 14B
N= 76

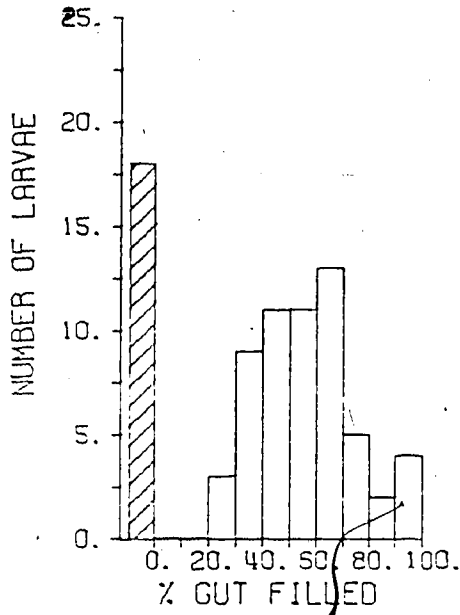

MEDIUM 14B
N=345

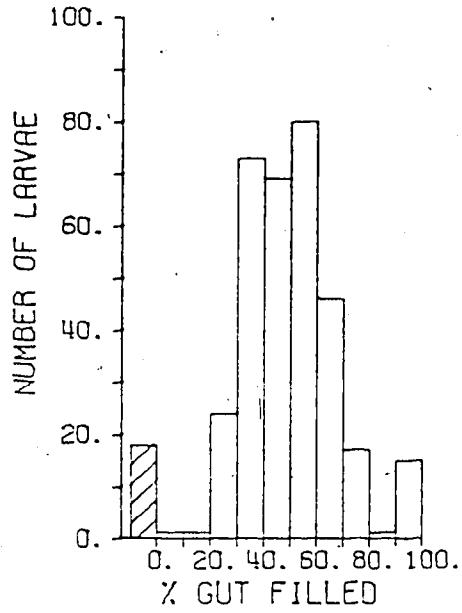

LARGE 14B
N= 79

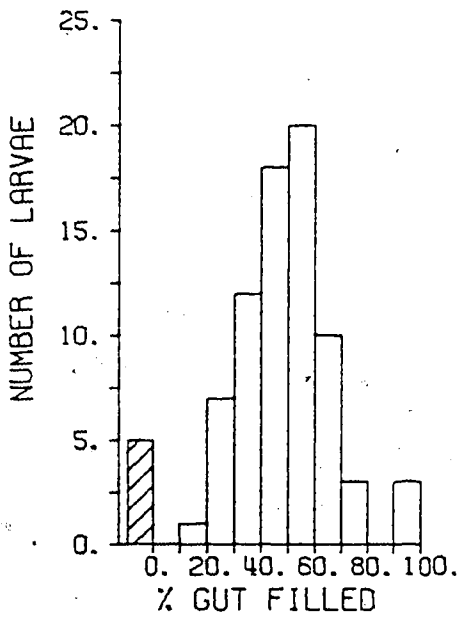

LARGE P. 14B
N= 23

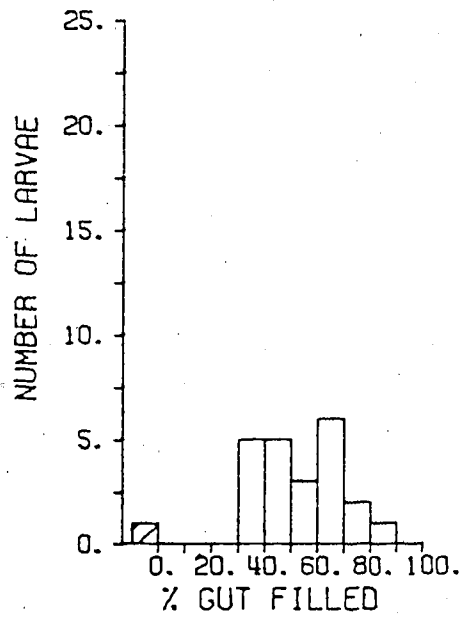

cont'd.

Appendix F, cont'd.

SMALL 15A
N= 69

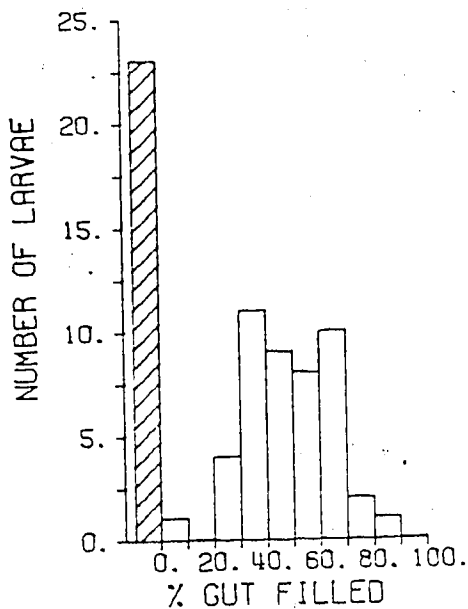

MEDIUM 15A
N=290

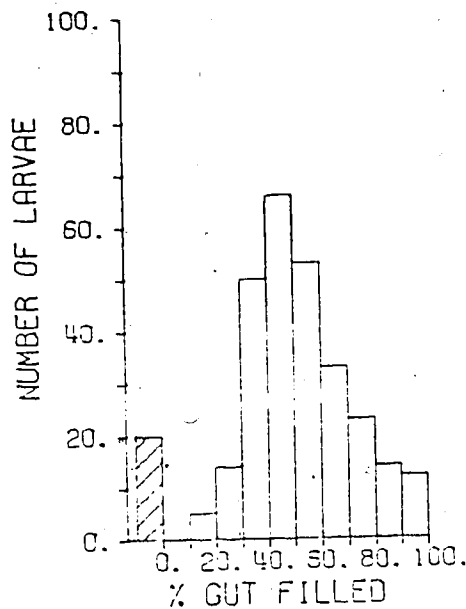

LARGE 15A
N= 96

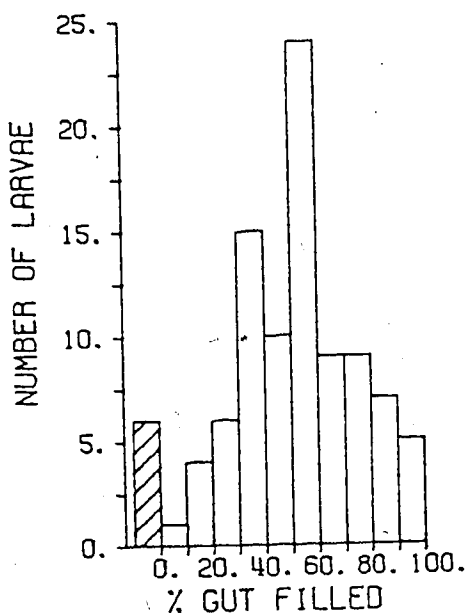

LARGE P. 15A
N= 57

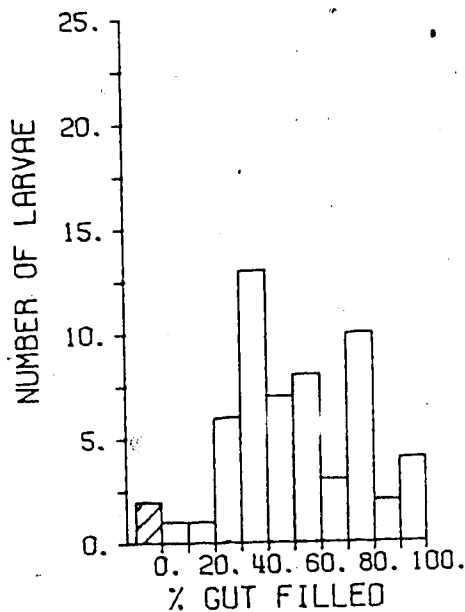

cont'd.

Appendix F, cont'd.

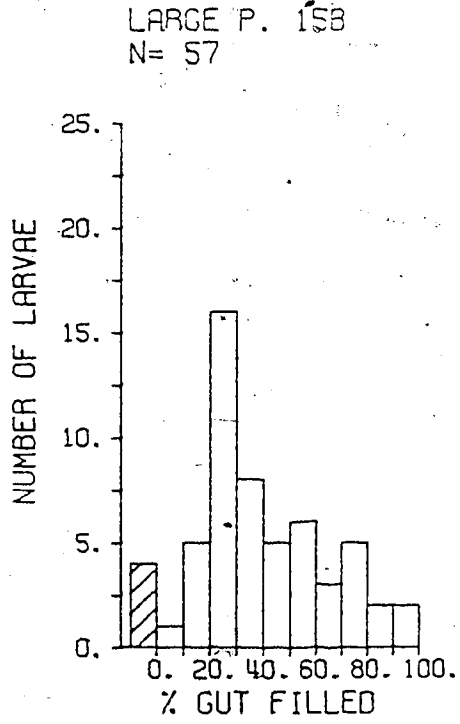
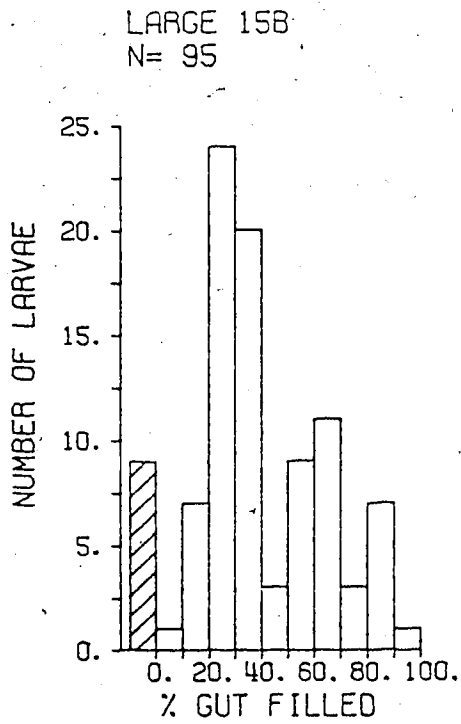
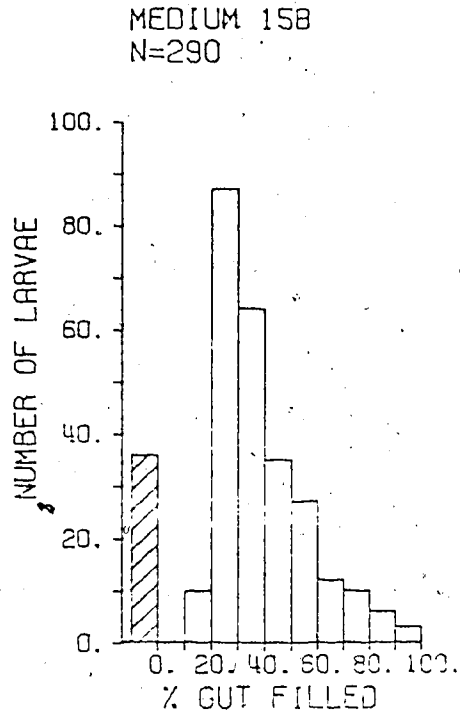
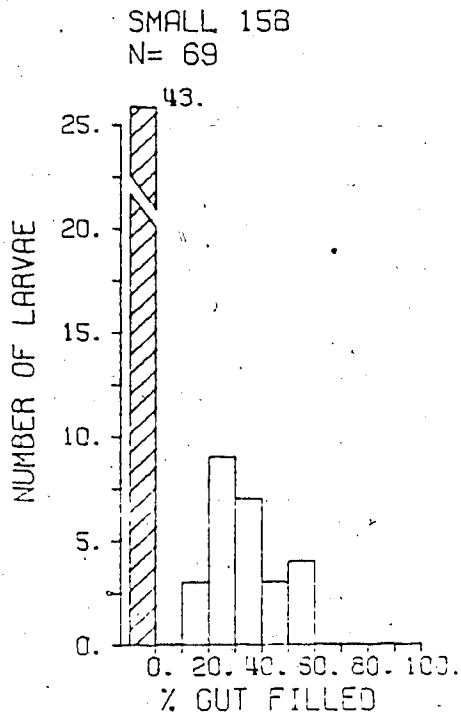

Appendix G.

Table I. Mean (arcsine) percentage gut filled of larvae
of *Simulium vittatum*¹

Expt. No.	Time (min)	Larval Class			
		Small (n)	Medium (n)	Large (n)	Large p. (n)
10b	30	--	47.80 (318)	55.74 (49)	--
5b		46.60 (48)	48.00 (311)	48.41 (34)	53.14 (42)
7		--	52.83 (278)	49.88 (35)	50.58 (28)
6		--	46.70 (208)	45.52 (22)	40.04 (50)
14b		49.09 (58)	45.42 (327)	45.03 (79)	47.51 (22)
2		48.88 (37)	45.49 (147)	54.46 (35)	49.40 (44)
1b		47.24 (58)	43.03 (211)	30.95 (43)	33.30 (212)
3		45.22 (39)	44.84 (261)	--	41.63 (26)
8b		37.24 (19)	42.74 (325)	42.29 (73)	43.59 (38)
4b		45.46 (19)	41.82 (74)	47.12 (33)	46.21 (39)
15b		35.05 (26)	38.60 (254)	40.62 (86)	40.46 (53)
9b		--	41.32 (291)	40.72 (66)	51.39 (32)
12b	60	--	48.71 (286)	49.60 (67)	--
14a		--	53.15 (296)	52.45 (80)	52.77 (23)
11b		--	52.06 (279)	52.83 (73)	--
13b		45.79 (43)	43.72 (214)	44.66 (43)	44.85 (33)
8a		43.98 (19)	54.42 (355)	53.92 (74)	48.47 (38)
9a		--	46.53 (289)	46.03 (67)	53.67 (36)
15a		44.09 (46)	46.97 (270)	47.53 (90)	46.71 (55)
10a	90	--	57.32 (357)	57.02 (52)	--
12a		--	58.53 (357)	59.27 (71)	--
5a		50.73 (50)	55.93 (330)	53.13 (33)	52.99 (41)
11a		--	60.66 (384)	62.08 (79)	60.19 (19)
1a		52.35 (123)	51.97 (280)	47.14 (34)	47.19 (197)
13a		47.75 (72)	47.46 (250)	45.79 (57)	47.45 (35)
4a		45.40 (19)	47.73 (218)	49.65 (38)	49.35 (44)

¹ Grouped according to time and availability of particles (p. 92).

Appendix G.

Table II. Differences between means of (arcsine) percentage gut filled by larvae of *Simulium vittatum* determined by Duncan's New Multiple Range Test

Expt.	Test ¹	LSR _{0.05}	LSR _{0.01}	$ \bar{x} - \bar{x} $	Signif.	Class with greater \bar{x}
1a	L,M	3.988	5.198	4.83	*	M
	L,S	5.727	7.120	5.21	insig.	
	M,S	3.519	4.625	0.38	insig.	
	L,Lp	0.38	0.456	0.03	insig.	
1b	L,M	4.615	6.099	12.08	**	M
	L,S	5.906	7.343	16.29	**	S
	M,S	4.809	6.319	4.19	insig.	
2	L,M	4.491	5.902	8.97	**	L
	L,S	5.777	7.592	5.58	insig.	
	M,S	4.375	5.757	3.39	insig.	
	L,Lp	6.662	8.836	5.06	insig.	
3	L,M	6.196	8.142	0.02	insig.	
	L,S	7.120	9.344	0.39	insig.	
	M,S	3.952	5.194	0.37	insig.	
	L,Lp	1.819	3.199	3.20	**	L †
4a	L,M	4.766	6.263	1.92	insig.	
	L,S	8.970	11.152	4.19	insig.	
	M,S	6.384	8.391	2.27	insig.	
	L,Lp	6.764	8.889	0.30	insig.	
4b	L,M	5.689	7.535	5.35	insig.	
	L,S	7.615	10.007	1.71	insig.	
	M,S	6.478	8.589	3.64	insig.	
	L,Lp	7.341	9.650	0.96	insig.	

¹ L = large larvae, M = medium larvae, S = small larvae, Lp = large parasitized larvae.

† denotes those tests which differ in significance from the results of analysis of variance (fig. 2, 3a, b, c).

* = probability of 0.05 or less, ** = probability of 0.01 or less.

cont'd.

Appendix G. Table II, cont'd.

Expt.	Test ¹	LSR _{0.05}	LSR _{0.01}	$ \bar{x} - \bar{x} $	Signif.	Class with greater \bar{x}
5a	L,M	4.105	5.395	2.80	insig.	
	L,S	5.740	7.544	2.40	insig.	
	M,S	3.394	4.477	5.20	**	M
	L,Lp				(assumed insig.)	
5b	L,M	4.124	5.420	0.41	insig.	
	L,S	4.898	6.089	1.81	insig.	
	M,S	1.657	2.178	1.40	insig.	
	L,Lp	6.630	8.715	2.73	insig.	
6	L,M	4.579	6.018	1.18	insig.	
	L,Lp	5.178	6.926	5.48	*	L
7	L,M	4.279	5.715	2.95	insig.	
	L,Lp	6.106	8.115	0.70	insig.	
8a	L,M	2.918	3.836	0.45	insig.	
	L,S	6.229	8.258	9.99	**	L
	M,S	5.488	7.213	10.44	**	M
	L,Lp	4.712	6.325	5.50	*	L
8b	L,M	2.799	3.679	0.45	insig.	
	L,S	5.161	6.654	5.05	insig.	+
	M,S	8.682	10.794	5.50	insig.	
	L,Lp	4.644	6.152	1.30	insig.	
9a	L,M	3.021	3.970	0.50	insig.	
	L,Lp	5.734	6.772	7.64	**	Lp
9b	L,M	3.309	4.349	0.68	insig.	
	L,Lp	6.597	7.407	10.62	**	Lp
10a	L,M	4.502	6.021	7.94	**	L
	L,Lp	9.768	12.990	2.65	insig.	
10b	L,M	3.525	4.633	0.30	insig.	
	L,Lp	7.946	10.560	1.33	insig.	
11a	L,M	3.013	3.959	1.42	insig.	
	L,Lp	6.231	8.241	1.89	insig.	
11b	L,M	3.085	4.054	0.77	insig.	
	L,Lp	6.443	8.538	2.36	insig.	

cont'd.

Appendix G. Table II, cont'd.

Expt.	Test ¹	LSR _{0.05}	LSR _{0.01}	$ \bar{x} - \bar{x} $	Signif.	Class with greater \bar{x}
12a	L,M	8.726	11.468	0.74	insig.	
12b	L,M	2.586	3.398	0.89	insig.	
13a	L,M	3.522	4.629	1.96	insig.	
	L,S	5.063	6.295	1.96	insig.	
	M,S	3.185	4.185	0.29	insig.	
	L,Lp	5.061	6.710	1.66	insig.	
13b	L,M	3.878	5.096	0.94	insig.	
	L,S	4.995	6.564	1.13	insig.	
	M,S	3.883	5.103	2.07	insig.	
14a	L,M	2.844	3.737	0.70	insig.	
	L,S	6.167	8.105	4.56	insig.	
	M,S	5.596	7.355	5.26	insig.	
	L,Lp	5.842	6.900	0.69	insig.	
14b	L,M	2.705	3.555	0.39	insig.	
	L,S	3.589	4.461	4.06	*	S
	M,S	2.993	3.934	3.67	*	S
	L,Lp	4.763	6.298	2.48	insig.	
15a	L,M	2.810	3.694	2.02	insig.	
	L,S	5.895	7.329	5.57	insig.	
	M,S	5.920	7.781	3.55	insig.	
	L,Lp	4.781	6.284	0.16	insig.	
15b	L,M	2.857	3.755	0.56	insig.	
	L,S	5.083	6.320	3.44	insig.	
	M,S	3.562	4.681	2.88	insig.	
	L,Lp	4.732	6.256	0.82	insig.	

Appendix H. Tests of independence (G-test) between feeding
larval class, and experiments

Large, medium and small larvae. 30-minute experiments.

Test	G	df	P
F x E x C	1859.6	47	***
F x E	862.4	9	***
C x E	461.0	18	***
F x C	549.0	27	***
interaction	-12.8	18	insig.
	<u>1859.6</u>	<u>47</u>	

Conditional independence of C over F:

	448.2	36	***
unfed	218.2	18	***
fed	<u>229.6</u>	<u>18</u>	***
	447.8	36	

Independence over E, of C x F: $862.4 + 1310.6$, $df = 40$, ***

Conditional independence of F over C:

	849.2	27	***
Large	42.6	9	***
Medium	689.4	9	***
Small	<u>117.4</u>	<u>9</u>	***
	849.4	27	

Independence over E, of C x F: $849.6 + 461.0 = 1310.6$, $df = 40$, ***

Partitioning for negative interaction:

F x E int.	53315.0	9	***
(F x E), C int.	-52465.4	18	***
Condit. ind. F over C:	<u>849.6</u>	<u>27</u>	
C x E int.	51504.4	18	
(C x E), F int.	-51056.2	18	
Condit. ind. C over F:	<u>448.2</u>	<u>36</u>	

F = feeding, C = larval class, E = experiments, int. = interaction
abc

$G = 2 \sum f_{ijk} \ln (f_{ijk})$; $df = abc - a - b - c + 2$ (Sokal and Rohlf 1969).

*** = Probability of 0.001 or less, ** = Probability of 0.01 or less,

* = Probability of 0.05 or less.

Appendix H, cont'd.

Large, medium and small larvae. 60-minute experiments.

Test	G	df	P
F x E x C	441.0	17	***
F x E	122.8	3	**
C x E	58.8	6	***
F x C	252.0	2	***
interaction	7.4	6	insig.
	<u>441.0</u>	<u>17</u>	

Conditional independence C over F:

	66.2	12	***
unfed	16.2	6	*
fed	49.6	6	***
	<u>65.8</u>	<u>12</u>	

Independence over E, of F x C: $122.8 + 65.8 = 189.0$, $df = 15$, ***

Conditional independence F over C: --

	130.2	9	***
Large	29.6	3	***
Medium	67.6	3	***
Small	32.6	3	***
	<u>129.8</u>	<u>9</u>	

Independence over E, of F x C: $130.2 + 58.8 = 188.8$, $df = 15$, ***

cont'd.

Appendix H, cont'd.

Large, medium and small larvae. 90-minute experiments.

Test	G	df	P
F x C x E	454.6	17	***
F x E	130.8	3	***
C x E	136.6	6	***
F x C	198.8	6	***
interaction	<u>-11.6</u>	<u>6</u>	insig.
	454.6	17	

Conditional independence C over F:

	125.0	12	***
unfed	44.0	6	***
fed	<u>81.4</u>	<u>6</u>	***
	125.4	12	

Independence over E, of F x C: $125.0 + 130.8 = 255.8$, df = 15, ***

Conditional independence F over C:

	119.2	9	***
Large	25.0	3	***
Medium ,	64.8	3	***
Small	<u>29.4</u>	<u>3</u>	***
	119.2	9	

Independence over E, of F x C: $119.2 + 136.6 = 255.8$, df = 15, ***

Partitioning for negative interaction:

F x E int.	25035.2	3	***
(E x F), C int.	<u>-24916.0</u>	<u>6</u>	***
Condit. ind. F over C:	119.2	9	***
E x C int.	24196.2	6	***
(E x C), F int.	<u>-24071.1</u>	<u>6</u>	***
Condit. ind. C over F:	125.2	12	***

cont'd.

Appendix H, cont'd.

Large, medium, and large parasitized larvae. 30-minute experiments

Test	G	df	p
F x E x C	1306.8	57	***
F x E	608.0	11	***
C x E	437.0	22	***
F x C	105.8	2	***
interaction	<u>156.0</u>	<u>22</u>	***
	1306.8	57	

Conditional independence C over F:

	593.0	44	***
unfed	52.6	22	***
fed	<u>540.4</u>	<u>22</u>	***
	593.1	44	

Independence over E, of F x C: $608.0 + 593.0 = 1201.0$, df = 55, ***

Conditional independence F over C:

	764.0	33	***
Large	44.8	11	***
Medium	697.2	11	***
Large P.	<u>22.0</u>	<u>11</u>	*
	764.0	33	

Independence over E of F x C: $437.0 + 764.0 = 1201.0$, df = 55, ***

cont'd.

Appendix H, cont'd

Large, medium, and large parasitized larvae. 60-minute experiments.

Test	G	df	P
F x E x C	148.2	22	***
F x E	101.4	4	***
C x E	27.0	8	***
F x C	10.2	2	***
interaction	<u>9.6</u>	<u>8</u>	insig.
	148.2	22	

Conditional independence of C over F:

	36.6	16	***
unfed	9.8	8	insig.
fed	<u>26.8</u>	<u>8</u>	***
	36.6	16	

Independence over E, of F x C: $36.6 + 101.4 = 138.0$, $df = 20$, ***

Conditional independence of F over C:

	111.0	12	***
Large	30.4	4	***
Medium	76.2	4	***
Large P.	<u>4.4</u>	<u>4</u>	insig.
	111.0	12	

Independence over E, of F x C: $111.0 + 27.0 = 138.0$, $df = 20$, ***

cont'd.

Appendix H, cont'd.

Large, Medium, and large parasitized larvae. 90-minute experiments.

Test	G	df	P
F x E x C	410.6	22	***
F x E	100.8	4	***
C x E	251.8	8	***
F x C	17.0	2	***
interaction	<u>41.0</u>	<u>8</u>	***
	410.6	22	

Conditional independence of C over F:

	292.8	16	***
unfed	31.6	8	***
fed	<u>261.4</u>	<u>8</u>	***
	293.0	16	

Independence over E, of F x C: $293.0 + 100.8 = 393.6$, df = 20, ***

Conditional independence of F over C:

	141.8	12	***
Large	43.0	4	***
Medium	94.4	4	***
Large P.	<u>5.2</u>	<u>4</u>	insig.
	142.6	12	

Independence over E, of F x C: $141.8 + 251.8 = 393.6$, df = 20, ***