

1-315-03611-5



National Library of Canada

Bibliothèque nationale du Canada

Canadian Theses Division

Division des thèses canadiennes

Ottawa, Canada
K1A 0N4

51586

PERMISSION TO MICROFILM — AUTORISATION DE MICROFILMER

• Please print or type — Écrire en lettres moulées ou dactylographier

Full Name of Author — Nom complet de l'auteur

David Edward Somers

Date of Birth — Date de naissance

14 December 1954

Country of Birth — Lieu de naissance

U.S.A.

Permanent Address — Résidence fixe

1262 Orchardview Rd Seven Hills, Ohio 44131 U.S.A

Title of Thesis — Titre de la thèse

An Investigation into the Environmental Control of Cold Acclimation in High Arctic Populations of *Salix arctica* and *Saxifraga oppositifolia*

University — Université

U of Alberta

Degree for which thesis was presented — Grade pour lequel cette thèse fut présentée

M.Sc.

Year this degree conferred — Année d'obtention de ce grade

1981

Name of Supervisor — Nom du directeur de thèse

L.C. Bliss

Permission is hereby granted to the NATIONAL LIBRARY OF CANADA to microfilm this thesis and to lend or sell copies of the film.

L'autorisation est, par la présente, accordée à la BIBLIOTHÈQUE NATIONALE DU CANADA de microfilmer cette thèse et de prêter ou de vendre des exemplaires du film.

The author reserves other publication rights, and neither the thesis nor extensive extracts from it may be printed or otherwise reproduced without the author's written permission.

L'auteur se réserve les autres droits de publication; ni la thèse ni de longs extraits de celle-ci ne doivent être imprimés ou autrement reproduits sans l'autorisation écrite de l'auteur.

Date

1 April 1981

Signature

David E Somers



National Library of Canada
Collections Development Branch

Canadian Theses on
Microfiche Service

Bibliothèque nationale du Canada
Direction du développement des collections

Service des thèses canadiennes
sur microfiche

NOTICE

The quality of this microfiche is heavily dependent upon the quality of the original thesis submitted for microfilming. Every effort has been made to ensure the highest quality of reproduction possible.

If pages are missing, contact the university which granted the degree.

Some pages may have indistinct print especially if the original pages were typed with a poor typewriter ribbon or if the university sent us a poor photocopy.

Previously copyrighted materials (journal articles, published tests, etc.) are not filmed.

Reproduction in full or in part of this film is governed by the Canadian Copyright Act, R.S.C. 1970, c. C-30. Please read the authorization forms which accompany this thesis.

**THIS DISSERTATION
HAS BEEN MICROFILMED
EXACTLY AS RECEIVED**

AVIS

La qualité de cette microfiche dépend grandement de la qualité de la thèse soumise au microfilmage. Nous avons tout fait pour assurer une qualité supérieure de reproduction.

S'il manque des pages, veuillez communiquer avec l'université qui a conféré le grade.

La qualité d'impression de certaines pages peut laisser à désirer, surtout si les pages originales ont été dactylographiées à l'aide d'un ruban usé ou si l'université nous a fait parvenir une photocopie de mauvaise qualité.

Les documents qui font déjà l'objet d'un droit d'auteur (articles de revue, examens publiés, etc.) ne sont pas microfilmés.

La reproduction, même partielle, de ce microfilm est soumise à la Loi canadienne sur le droit d'auteur, SRC 1970, c. C-30. Veuillez prendre connaissance des formules d'autorisation qui accompagnent cette thèse.

**LA THÈSE A ÉTÉ
MICROFILMÉE TELLE QUE
NOUS L'AVONS REÇUE**

THE UNIVERSITY OF ALBERTA

An Investigation into the Environmental Control of Cold
Acclimation in High Arctic Populations of *Salix arctica* and
Saxifraga oppositifolia

by

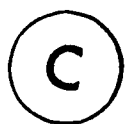

David Edward Somers

A THESIS

SUBMITTED TO THE FACULTY OF GRADUATE STUDIES AND RESEARCH
IN PARTIAL FULFILMENT OF THE REQUIREMENTS FOR THE DEGREE
OF MASTER OF SCIENCE

IN

PLANT ECOLOGY

BOTANY

EDMONTON, ALBERTA

SPRING, 1981

THE UNIVERSITY OF ALBERTA

RELEASE FORM

NAME OF AUTHOR David Edward Somers
TITLE OF THESIS An Investigation into the Environmental
Control of Cold Acclimation in High
Arctic Populations of *Salix arctica* and
Saxifraga oppositifolia
DEGREE FOR WHICH THESIS WAS PRESENTED MASTER OF SCIENCE
YEAR THIS DEGREE GRANTED SPRING, 1981

Permission is hereby granted to THE UNIVERSITY OF ALBERTA LIBRARY to reproduce single copies of this thesis and to lend or sell such copies for private, scholarly or scientific research purposes only.

The author reserves other publication rights, and neither the thesis nor extensive extracts from it may be printed or otherwise reproduced without the author's written permission.

(SIGNED)

David E. Somers

PERMANENT ADDRESS:

*1262 Orchard View Rd.
Seven Hills, Ohio 44131
U.S.A.*

DATED

13 March 1981

THE UNIVERSITY OF ALBERTA
FACULTY OF GRADUATE STUDIES AND RESEARCH

The undersigned certify that they have read, and recommend to the Faculty of Graduate Studies and Research, for acceptance, a thesis entitled "An Investigation into the Environmental Control of Cold Acclimation in High Arctic Populations of *Salix arctica* and *Saxifraga oppositifolia*" submitted by David Edward Somers in partial fulfilment of the requirements for the degree of MASTER OF SCIENCE in PHYSIOLOGICAL ECOLOGY.

... *Laurence Bliss* ...

Supervisor

... *John Heddinott* ...

... *Jama M. Mayo* ...

... *Kenneth O'Higgins* ...

Date... *13 March 1981* ...

Abstract

On Truelove Lowland, Devon Island, N.W.T., high arctic populations of *Salix arctica* and *Saxifraga oppositifolia* were studied to determine if the environmental cues involved in cold acclimation in these species differ from those which induce hardiness in temperate plants. Field treatments altered the quality, intensity or duration of radiation received by the plants. Measurements of seasonal changes in the red:far-red and red:blue ratios at this latitude (75°N) were compared to predictions from a radiation model. Leaf and shoot cold hardiness, along with leaf water potential were sampled throughout the growing season. Studies were continued in the laboratory under controlled environments.

Growth under a reduced red:far-red ratio (-red) or an increased red:blue ratio (-blue) light regime did not affect the cold hardiness of *Salix arctica* leaves. The mean seasonal LT 50 (\pm SEM) for the combined treatments was $-8.6 \pm .4^{\circ}\text{C}$. Short days accelerated leaf senescence and may have slightly increased leaf hardiness (-12.5°C) prior to senescence, after which cold tolerance decreased (-6.4°C). Increased internal solute concentration associated with senescence may have caused the brief increase. Under controlled conditions, leaf hardiness was estimated to be near -7°C .

Stem hardiness (LT 50) of field plants with no signs of senescence was between -15° and -18°C . At the same time, plants undergoing leaf senescence were tolerant to near

-27°C. Stems survived to <-44°C by completion of senescence, even when held at +5°C under continuous light. Dormant plants held at -10°C survived immersion in liquid nitrogen, but hardiness decreased to near -12°C during active growth and increased to <-20°C as leaf senescence began; with no change in environmental conditions. Although short days and a far-red night treatment both induced greater hardiness earlier than normal, endogenous factors appear to control cold acclimation in the field, possibly through increased sensitivity to low temperatures (+5 to -5°C), which act to initiate the metabolic and physical changes necessary for very low temperature survival. Despite shifts in the red:far-red ratio near the end of the growing season, there was no evidence that plants used these changes to cue cold acclimation or dormancy.

Endogenous control of dormancy and cold acclimation was also implicated in *Saxifraga oppositifolia*. Plants became cold hardy to near -40°C while maintained at +5°C at the end of a normal growing season. Untreated field plants were hardy to between -15° and -19°C during most of the season, and to near -9°C under controlled environments. The greater tolerance of the field plants may have been due to lower root temperatures and slight water stress. Short days accelerated senescence of second-year leaves and hastened increased hardiness.

Leaf water potential of *Salix arctica* in the field was generally above -1.40 MPa. Under controlled conditions, leaf

water potential ranged between -0.7 and -1.0 MPa. Osmotic potential was low (-1.85 to -2.11 MPa) and probably contributes to the maintenance of leaf cold hardiness. Turgor was high in mature leaves (1.10 to 1.20 MPa), but low values in expanding leaves (0.3 MPa) suggests high cell wall plasticity at this time. The hastening of senescence through short days may have caused the marked decrease in water potential near the end of the field studies.

Under controlled conditions, leaf water potential of *Saxifraga oppositifolia* was in the same range as *Salix arctica*. Osmotic potential was generally between -1.20 and -1.40 MPa, and turgor remained near 0.4 MPa throughout the study. The treatments did not significantly affect the water relations of *Saxifraga oppositifolia*. In the field, leaf water potentials were often between -1.0 and -1.40 MPa. The short day plants had much lower values (<-1.80 MPa). Increased root resistance and decreased stomatal resistance may have been the cause.

Acknowledgements

Dr. L.C. Bliss provided the opportunity for travel and study in the Arctic, as well as contributing financially to this study, and I greatly appreciated his assistance in both areas. His efforts in maintaining contact over the many miles from Seattle, and concern and support for the continued progress on this thesis were a great help. My other committee members (Drs. J. Hoddinott, J. M. Mayo and K. Higginbotham) are also appreciated for their editorial comments and encouragement. Dr. J. Hoddinott served admirably as my "surrogate" supervisor. Dr. J. M. Mayo was invaluable, not only for our many conversations on cold hardiness and water relations, but for the other numerous discussions which ranged from the esoteric to the down-to-earth.

The Boreal Institute for Northern Studies provided additional financing of this study and their aid was appreciated. The Department of Botany gave financial assistance in the forms of a teaching assistantship, demonstratorship and summer stipends.

Phil Wright willingly gave of his time to aid in my search for a suitable, portable low temperature bath, and his success surmounted a major obstacle at the beginning of this work. Art McKinnon, through the Department of Microbiology, kindly loaned me the bath for field and laboratory use. I also appreciated John Konkin's efforts in keeping my growth chambers running.

A large number of other people have contributed, directly and indirectly, to this work and a few deserve special mention: thanks to Bruce Pattison, for his able assistance in the field, particularly for meeting the challenge of thermocouple psychrometry; to Dave Hackett, who's poetic pen and ready wit enlivened the long hours in the Parcoll; to the inimitable Peter Nosko, who contributed to my arctic experience in more ways than I can mention here and was personally responsible for some unforgettable moments (thanks also for his help in data collection); and to Ward Elcock for his efficient running of the camp.

I am particularly grateful to Leni Honsaker and Dr. Walter Moser whose translations provided my access to relevant German literature. Doug Whitfield was very helpful during the construction of the narrow waveband sensors, aided me with FORTRAN, and offered some welcome constructive criticism of the radiation model. John Campbell contributed in a myriad of small ways which added up to a significant effect on my progress and completion of this study. His readiness to listen and advise, and even his role as devil's advocate were much appreciated. Bill Russell, George Davis, Bill Lee and Sylvia L'Hirondelle were all very helpful with various aspects of computer use; from the deciphering of FORTRAN to the more efficient use of TEXTFORM. A special thanks to the budding basement botanists for their support and enthusiasm during the final stages of this thesis.

Table of Contents

Chapter	Page
I. Introduction	1
A. Hardiness in Temperate, Alpine and Arctic Regions	1
B. Cold Acclimation Mechanism - A Working Model	4
C. The Problem and Approach	10
II. Materials and Methods	16
A. Plant materials	16
B. General Materials and Methods	17
1. Cold hardiness technique	17
2. Water relations	26
C. Field Studies	27
1. Site description	27
2. Experimental treatments	29
3. Phenology	36
4. Environmental measurements	36
5. Sampling frequency	40
D. Controlled Environment Studies	41
1. Experimental treatments	41
2. Sampling frequency	44
III. Results and Discussion	45
A. Environmental Characterization of Field Site ...	45
1. Radiation	45
2. Temperature and Vapor Pressure Deficit ...	59
3. Soils: Depth of Thaw	63

B. Effects of Treatments on Local Plant Environment	66
1. Radiation	66
2. Temperature	72
3. Wind	85
4. Soil Moisture	87
C. <u>Salix arctica</u>	88
1. Field Phenology	88
2. Field Cold Hardiness	99
3. Controlled Environment Phenology	113
4. Lab Cold Hardiness	117
5. Synthesis	124
6. Field Water Relations	129
7. Controlled Environment Water Relations ..	142
8. Synthesis	147
D. <u>Saxifraga oppositifolia</u>	151
1. Phenology	151
2. Cold Hardiness	155
3. Field Water Relations	165
4. Controlled Environment Water Relations ..	172
5. Synthesis	176
IV. Summary and Conclusions	180
V. Literature Cited	186
VI. Appendices	207
Appendix 1	208
Appendix 2	211
Appendix 3	214

List of Tables

Table 1. Experimental and control growth regimes used in the controlled environment studies.....	42
Table 2. Treatment comparisons of mean leaf, soil surface and subsurface temperatures obtained from thermocouple spot readings.....	75
Table 3. Comparison of wind speeds beside and beneath dome treatments.....	86
Table 4. Cold hardiness of <i>Salix arctica</i> stems in relation to phenology.....	126
Table 5. Cold hardiness of <i>Saxifraga oppositifolia</i> in response to the controlled environment treatments....	162
Table 6. Summary of the results of this study in relation to the seasonal pattern of cold acclimation in <i>Salix arctica</i> and <i>Saxifraga oppositifolia</i>	185

List of Figures

- Fig. 1. The correlation between stress temperature and the reduction of triphenyl tetrazolium chloride (TTC) by *Salix arctica* leaf tissue.....20
- Fig. 2. Correlation between the post-freezing survival of *Salix arctica* stem tissue and the percentage reduction of TTC.....21
- Fig. 3. Correlation between post-freezing survival of *Salix arctica* leaf disks after one week in Hoagland's solution and the percentage reduction of TTC.....23
- Fig. 4. Correlation between post-freezing survival of *Saxifraga oppositifolia* stem sections and percentage reduction of TTC.....25
- Fig. 5. Location of (A) the 1978 field site, (B) Base Camp and (C) the I.B.P. Intensive Raised Beach site on Truelove Lowland, Devon Island.....28
- Fig. 6. Transmittance characteristics of the red and blue filters between 400-730 nm.....31
- Fig. 7. A representative Plexiglass dome and color filter used to alter the light regime of the underlying plant.....33
- Fig. 8. Bucket arrangement used to artificially shorten days.....34
- Fig. 9. Arrangement of treatments within the study site...35
- Fig. 10. Representative spectra of the growth chambers used in the laboratory treatments shown in Table 1....43
- Fig. 11. Total global radiation (280-2800 nm) recorded at the 1978 field site and presented as 5 day means...46

Fig. 12. Measured diurnal variation in zeta between 21 July and 29 July 1978.....	48
Fig. 13. Measured diurnal variation in zeta between 29 July and 22 August 1978.....	49
Fig. 14. Predicted diurnal variation in zeta at latitude 75°33'N, longitude 84°40'W on 6 July and 6 August.....	52
Fig. 15. Measured diurnal variation in red:blue ratios between 29 July and 22 August.....	56
Fig. 16. Predicted diurnal variation in red:blue ratios at latitude 75°33'N, longitude 84°40'W on 6 July and 6 August.....	58
Fig. 17. Variation in air temperature during July and August presented as 5 day means.....	60
Fig. 18. Variation in vapor pressure deficit (VPD) during July and August presented as 5 day means.....	62
Fig. 19. Development of active layer in relation to the receding snow front.....	64
Fig. 20. Accumulated degree events for <i>Salix arctica</i> leaf temperatures.....	73
Fig. 21. Accumulated degree events for <i>Saxifraga oppositifolia</i> leaf temperatures.....	74
Fig. 22. Accumulated degree events for <i>Salix arctica</i> soil surface (0 cm) temperatures.....	77
Fig. 23. Accumulated degree events for <i>Saxifraga oppositifolia</i> soil surface (0 cm) temperatures.....	78
Fig. 24. Accumulated degree evnts for <i>Salix arctica</i> soil (-5 cm) temperatures.....	79
Fig. 25. Accumulated degree events for <i>Saxifraga</i>	

<i>oppositifolia</i> soil (-5 cm) temperatures.....	80
Fig. 26. Comparison between beneath and beside dome variation in 1978 soil moisture.....	89
Fig. 27. Effects of experimental field treatments on the phenology of <i>Salix arctica</i> during 1978.....	90
Fig. 28. Hypothetical changes in phytochrome photoequilibria (\emptyset).....	94
Fig. 29. Effects of the field treatments on the cold hardiness of <i>Salix arctica</i> leaf tissue.....	100
Fig. 30. Cold hardiness of <i>Salix arctica</i> stem tissue during early August 1978.....	111
Fig. 31. Effects of the laboratory treatments on the phenology of <i>Salix arctica</i>	114
Fig. 32. Effects of the laboratory treatments on the cold hardiness of <i>Salix arctica</i> stem tissue.....	118
Fig. 33. Diurnal variation in leaf water potential of <i>Salix arctica</i> control plants under field conditions..	130
Fig. 34. Effects of field treatments on the total leaf water potential of <i>Salix arctica</i>	135
Fig. 35. Effects of controlled environment treatments on the total leaf water potential of <i>Salix arctica</i>	143
Fig. 36. Effects of experimental field treatments on the, phenology of <i>Saxifraga oppositifolia</i> during 1978.....	152
Fig. 37. Cold hardiness of <i>Saxifraga oppositifolia</i> as affected by the the different field treatments.....	156
Fig. 38. Diurnal variation in leaf water potential of <i>Saxifraga oppositifolia</i> under field conditions.....	166

Fig. 39. Effects of field treatments on the total leaf water potential of *Saxifraga oppositifolia*.....169

Fig. 40. Effects of controlled environment treatments on the leaf water potential of *Saxifraga oppositifolia*..173

Fig. 41. Transmittance characteristics on the wideband filter used in the blue sensor.....209

Fig. 42. Internal design of the wave-length selective light sensors.....210

Fig. 43. Cosine response of the 660 nm, 730 nm, and 400-500 nm sensors.....212

Fig. 44. Cosine response of the ISCO spectroradiometer...213

Fig. 45. The ratio of global radiation at a given albedo to global radiation at an albedo of 0.....220

I. Introduction

A. Hardiness in Temperate, Alpine and Arctic Regions

Winter cold tolerance is an obvious necessity to plants which grow in the High Arctic. Mean air temperatures during January and February are generally between -30° and -35°C , with minimum air temperatures often -45° to -50°C (Savile 1972, Courtin and Labine 1977). Although extremely low temperatures do not often occur in the northern temperate zone, numerous woody species in this area are capable of surviving to -50°C and below. In some species, immersion in liquid nitrogen (-196°C) is tolerated (Sakai and Weiser 1973, George et al. 1974). These results suggest that extreme winter cold is not the limiting factor which precludes survival in the Arctic, and that the structural and biochemical changes required for low temperature tolerance are not unique to arctic species.

Similarly, summer cold hardiness in arctic plants, while unquestionably necessary to a certain degree, is not a feature required from only far northern (or southern) species. High mountain plants, most notably those of the afroalpine, regularly experience diurnal fluctuations in temperature which are often greater than those seen by arctic plants. The phrase "summer every day, winter every night" is used to describe the afroalpine environment where daytime air temperatures often rise to $>10^{\circ}\text{C}$ and fall nightly to near -5°C (Hedberg 1964). Leaf and soil

temperatures range much higher due to very high insolation. In contrast, continuous illumination at low sun angles during the arctic summer results in a reduced diurnal fluctuation of air temperature (ca. $<10^{\circ}\text{C}$). Throughout the growing season air (and leaf) temperatures rarely fall below 0°C (Warren Wilson 1957, Courtin and Labine 1977)

No determinations of cold hardiness of afroalpine species have been made. A variety of alpine species from Japan were tested for summer cold tolerance and most showed slight damage to leaves between -5° and -7°C . On *Vaccinium vitis-idaea*, *Rhododendron aureum*, *Salix pauciflora* and *Diappensia lapponica*, leaves were completely killed between -9° and -12°C , and the same occurred in *Ledum palustre* at -7°C . Stems of the same species were only slightly more cold hardy (Sakai and Otsuka 1970). Kainmüller (1975), working in the Karwendel mountains, reported heavy damage to the summer leaves of *Saxifraga oppositifolia*, *Silene acaulis*, *Carex firma* and *Soldanella alpina* at temperatures from -6° to -8°C . Buds of *Saxifraga* and *Silene* were frost tolerant to between -10° and -15°C , and the rhizomes were killed at -20° to -25°C . Ulmer (1937 in Biebl 1968) reported alpine herbs and dwarf shrubs to be frost hardy to between -3° and -6°C during the summer. Similarly, Pisek and Schiessel (1947 in Biebl 1968) found values for conifers and dwarf shrubs at timberline to be between -3° and -5°C .

A limited amount of investigation into the summer coldhardiness of arctic plants has shown lethal temperatures

to be very similar to those of alpine species. Biebl (1968) reported on the July frost tolerance of 20 arctic species from Godhavn, West Greenland (69° N) and found the leaves of most species to be killed or greatly damaged between -5° and -10°C. *Salix glauca* and *Vaccinium uliginosum* did not survive -6°C, while *Dryas integrifolia* and *Betula nana* were killed at -8°C. *Empetrum hermaphroditum*, *Diappensia lapponica* and *Saxifraga caespitosa* were undamaged at -8°C but killed at or above -12°C. In another work, Sakai noted that *Salix rotundifolia* from Barrow, Alaska (71°N) could resist freezing injury to only -5°C in late July (Sakai and Otsuka 1970). All the above studies suggest that there is no fundamental difference between arctic and alpine species with respect to the level of summer cold hardiness attained by the plants. Most of the minor discrepancies between studies can probably be accounted for by differences in hardiness assessment techniques.

The singular problem confronting arctic plants, then, is not in the attainment of unusual degrees of winter or summer cold hardiness. Rather it is in making the transition from summer activity to winter dormancy under the unique arctic conditions. A brief review of the cold acclimation processes of temperate plants will provide a background for comparison.

B. Cold Acclimation Mechanism - A Working Model

A model of cold acclimation for deciduous woody plants was put forth by Weiser (1970), based largely on work with *Cornus stolonifera*, and it has received relatively good support to the present time (Li et al. 1965, Hurst et al. 1967, van Huystee et al. 1967, Fuchigami et al. 1971b, McKenzie et al. 1974a,b,c, Chen et al. 1975, Chen and Li 1977, Harrison et al. 1978a). Weiser postulated a two stage process of acclimation. The first stage involves a photoperiodic stimulus received at above freezing temperatures for a few weeks which induces a limited degree of hardiness. This is followed by periods of frost or low temperature to attain the final hardiness level. Increasingly low temperatures can often increase the degree of hardiness induced by this second stage of acclimation.

Short days (8-9 h light/16-15 h darkness) are the first stage of acclimation. Short days (SD) alone were found to increase cold hardiness in *C. stolonifera* from -3° to -17°C (Harrison et al. 1978a). Despite previous reports of the necessity of growth cessation or bud dormancy before any cold acclimation can occur (van Huystee et al. 1967, Fuchigami 1971b), Harrison et al. (1978a) showed that a significant increase in hardiness through SD induction was possible at any time during the growing season. Similarly, bud dormancy was not found to be a prerequisite to SD induced hardening in *Acer negundo* and *Viburnum plicatum* (Irving and Lanphear 1967a). However, growth cessation, if

not necessary in all species, is still thought to be closely correlated with the ability to harden (e.g. Levitt 1972).

Later work implicated phytochrome as the pigment system mediating, through the leaves, the hardiness increase which occurs in the stem (Williams et al. 1972, McKenzie et al. 1974a). Production of translocatable hardiness inhibitors by long day leaves (Irving and Lanphear 1967b) or hardiness promoters by short day leaves (Fuchigami et al. 1971a, Howell and Weiser 1970) has been suggested to be at least partially responsible for the increase in stem hardiness (Weiser 1970). Presumably a light activated shift in the proportion of Pfr¹ to Ptot² initiates the production of these factors. A photosynthetic role for light during the hardening process has been suggested (e.g. Alden and Hermann 1971), but is probably linked more to the necessity for maintaining photosynthetic reserves to power the metabolic processes known to occur during hardening than to the need for photosynthesis *per se*.

Without a subsequent decrease in temperature, the degree of hardiness induced by short days will not increase. The second stage of acclimation involves low temperatures (-5° to +5°C) lasting from several days to weeks (Larcher et al. 1973). Under natural conditions the occurrence of below freezing minimum temperatures is often well correlated with a sharp increase in hardiness (Tumanov and Krasavtsev 1959, van Huystee et al. 1967, Howell and Weiser 1970, Harrison et

¹Pfr: amount of phytochrome in the far-red absorbing form.

²Ptot: total amount of phytochrome.

al. 1978a). Most workers expose the test plants to slightly below freezing temperatures (-2° to -5°C) for short periods of time (1-2 h) per day to obtain an increase in hardiness (McKenzie et al. 1974a, Wilkinson 1977, Harrison et al. 1978a), though a subfreezing period may not necessarily be required (Sakai 1966, Howell and Weiser 1970). More important than a freezing period may be the degree of difference between the current environmental temperature and the hardening temperature (Sakai 1966, Chen and Li 1978). The final degree of hardiness attained through low temperature acclimation varies with the species, ranging for temperate species from -35°C in *Cercis canadensis* (George et al. 1974) to -196°C in *C. stolonifera*, *Salix* spp., *Populus nigra* and others (Sakai 1966, Sakai 1970, Sakai 1973, Sakai and Weiser 1973, Harrison et al. 1978a). In the attainment of high degrees of cold resistance the rate of cooling is important, and deeper levels of resistance have been attained in woody species hardened under conditions of controlled cooling than under field conditions (Tumanov and Krasavtsev 1959).

There are exceptions to and constraints upon the general application of Weiser's (1970) model as outlined above. Hardiness can be increased by water stress (Alden and Hermann 1971, Wildung et al. 1973, Chen et al. 1975, Chen et al. 1977, Chen and Li 1978), and by low temperature alone (Krasavtsev 1969, Howell and Weiser 1970, Gusta and Weiser 1972, Irving and Lanphear 1967a). Chen and Li (1978) have

shown the combined effects of short days, low temperatures and water stress to be additive in increasing the hardiness of *C. stolonifera* seedlings. Other evidence suggests that while acclimation is most rapid when short days are followed by frost, low temperatures alone, over a longer time period, can induce the same level of hardiness (Howell and Weiser 1970).

The inability to harden plants at any time during the year, as well as the tendency for some plants to acclimate at the end of the season under noninductive conditions (long days, warm temperatures), has led to the speculation that endogenous rhythms are involved (Siminovitch et al. 1967, Schwarz 1970, Weiser 1970, Levitt 1972). *Cornus stolonifera* could not be acclimated early in the growing season (van Huystee et al. 1967) and Levitt (1972) suggested that freezing tolerance was inversely related to development. Later work with *C. stolonifera* showed that the frost induction stage of acclimation could not increase hardiness to below that obtained with short days until later in the growing period (Harrison et al. 1978a). Their results support earlier contentions that endogenous rhythms influence the physiologic state of the plant and its response to potentially inductive daylengths and temperatures (McKenzie et al. 1974a).

On the other hand, an endogenously controlled hardiness increase in the absence of external stimuli appears to occur in some species. Apple plants under long days and warm

temperatures increased slightly in frost tolerance at the end of the normal season (for field plants) (Howell and Weiser 1970). *Pinus cembra* and *Rhododendron ferrugineum* under constant warm temperatures and natural light conditions showed seasonal variation in hardiness comparable to field plants. A second year of the same treatment resulted in a reduced amplitude of freezing tolerance. Under constant short days the plants maintained a high resistance to low temperature damage throughout the year (Schwarz 1970).

Only a few of the numerous physiological changes involved in the cold acclimation of a plant or cell are relevant here. The nature of the biochemical mechanisms of freezing injury and frost resistance have been recently reviewed by a number of workers (Siminovitch et al. 1967, Mazur 1969, Weiser 1970, Alden and Hermann 1971, Levitt 1972, Heber and Santarius 1973, Burke et al. 1976, Heber and Santarius 1976).

An increase in solute concentration, especially sugars, has in many cases been correlated with an increase in cold hardiness (e.g. Levitt 1956 in Levitt 1972, Sakai 1962 in Sakai and Yoshida 1968, Alden and Hermann 1971, Sakai and Yoshida 1968, Heber and Santarius 1973). In this regard, it is interesting to note that subarctic populations of *Dactylis glomerata*, from Norway, had significantly higher fructosan levels in the leaf sheaths than Portugal populations (Eagles 1967). This may be related to the greater cold resistance in the northern populations (Cooper

1964). Other compounds such as proteins and amino acids (especially proline) have been implicated as cryoprotectants on occasion, but results have not been consistently correlative with hardiness (e.g. Yoshida and Sakai 1968, Levitt 1972).

The ability to survive dehydration is necessary for any cold hardy tissue. Freeze-dehydration occurs when, during the temperature decrease, intercellular water freezes first, resulting in a decreased vapor pressure outside the cell and subsequent diffusion of the intracellular water down the water potential gradient and through the cell membrane to freeze in the intercellular spaces (see Levitt 1972). Intercellular water freezes first because of lower solute concentrations. The loss of intracellular water increases the solute concentration resulting in a decreased vapor pressure which, as water continues to leave, eventually comes into equilibrium with the vapor pressure of the intercellular ice. The final degree of dehydration is dependent on the temperature and the water binding properties of the cell constituents.

A few studies have found a decrease in water potential and/or water content in woody species undergoing cold acclimation. In light of the freeze-dehydration phenomenon this is not unexpected. However, it is the short day treatment which causes the initial change in water relations, not freezing temperatures. Under short days, which induced the first stage of cold acclimation, the stem

water content and leaf water potential decreased and root resistance increased in *C. stolonifera* (McKenzie et al. 1974b, Parsons 1978). Similarly, in *Ledum groenlandicum* a decrease in relative water content and water potential of the evergreen leaves resulted under a short day/night frost regime (Wilkinson 1977). Possibly, short days induce the production or release of a translocatable factor (hormone) which results in the change in water relations seen in these studies (McKenzie et al. 1974b).

C. The Problem and Approach

The above brief review of the cold acclimation process allows arctic conditions and plants to be viewed in the context of temperate plant responses to the temperate environment. The major difference between the two areas with respect to Weiser's (1970) two stage cold acclimation model is the absence of the short day photoperiod during the period of dormancy and hardening in the Arctic. This obviously precludes the use of a shortened day for the induction of the first stage of cold acclimation. Although at lower arctic latitudes a shortened day (relative to the continuous light which normally prevails) may, theoretically, be used as a cue by plants, no such conditions occurred at the site of the present study.

At a latitude of 75°33' N, True Love Lowland sees the sun continuously above the horizon between 29 April and 17

August (Whitfield, unpub. data). Between this period the growing season on Truelove comes and goes. Svoboda (1977) reported the actual growing season (break of dormancy to 50% leaf coloration) of raised beach communities over a 3 year period (1970-1972) to be 60 days at the longest, occurring between 20 June and 18 August. Since at least one week (Chen and Li 1978) and generally two or more weeks (Harrison et al. 1978a) are required for the effects of short days to become manifest, it is apparent that continuous light would still be present at the time necessary to induce hardiness and dormancy by mid-August.

A second difference between temperate and arctic conditions is the presence during the arctic summer of temperatures low enough to possibly serve as the low temperature condition for the second stage of acclimation. Although air temperature does not regularly fall below 0°C, it can do so at any time during the season. Most often air temperatures are between 0° and 5°C, with plant and air temperatures very similar on overcast days. If arctic plants required the same magnitude of temperature difference between normal growing temperatures and hardiness inducing temperatures as temperate species do during active growth (ca. 10-15°C), the plants on Truelove would be waiting until early to mid-September, when temperatures are ca. -5° to -10°C, before becoming dormant. That this does not happen indicates that dormancy, and presumably some degree of cold hardening, occurs at near normal growing temperatures. It is

possible that only a slight increase above the regular summer hardiness occurs at this time (dormancy) and deeper levels come about as the temperature drops. Conversely, a very large increase in hardiness may be coincident with the onset of dormancy, with only deeper levels induced by extremely low (e.g. -50°C) temperatures.

Although Weiser's (1970) model may not be applicable to arctic plants in its classical form, the same mechanisms may be operating in different ways. The phytochrome-mediated increase in hardiness has been implicated in some species to be triggered by short days (McKenzie et al. 1974a, Williams et al. 1972), and could conceivably arise instead through a shift in the red(660 nm):far-red(730 nm) ratio (i.e. zeta) of the incident light. A concomittant shift in the Pfr:Ptot ratio (\emptyset) of the tissue would then initiate the same responses as done by short days.

McKenzie et al. (1974a) suggested a change in zeta as a possible cue for hardiness induction in *Cornus stolonifera*. Holmes and Smith (1975, 1977a,b) first demonstrated (through actual measurements) that the daily shift in magnitude of zeta, from sunrise to sunset, was potentially large enough to be used by the plant in photoperiodic timing. Recent work in plant growth and development has shown that plants can indeed respond in a measurable way to simulations of naturally occurring zeta ratios (Morgan and Smith 1976, 1978, 1979).

In light of the above information the following

objectives were proposed:

1. To elucidate the nature and mode of the environmental cues (if any) involved in the cold acclimation of two high arctic species with two different growth strategies.
2. To determine to what degree these plants are cold hardy, both during the growing season and during dormancy.
3. To examine leaf water potential in relation to hardiness and the arctic environment in general.

Salix arctica Pall. was of interest since it is one of the few woody deciduous species in the High Arctic, and has one of the widest tolerance ranges of all arctic species (Svoboda 1977). It provided an example of a plant with a unique growth strategy for the area and could be directly compared with woody deciduous temperate plants for which phytochrome-mediated control of cold acclimation has already been implicated.

Saxifraga oppositifolia L., in contrast to *Salix arctica*, is an ubiquitous winter green chameophyte of arctic and alpine areas. It is often the first species to break dormancy and flower at melt out.

The basic approach was to alter the radiation environments of field plants *in situ* in an attempt to induce premature hardiness and/or dormancy. An environment of reduced red light, resulting in a low zeta, was created for one set of plants to simulate the spectral energy distribution which naturally occurs at low sun angles (e.g.

Holmes and Smith 1977a). If plants were receptive to a marked decrease in zeta, which might normally occur near the end of the season as the sun approaches the horizon, this treatment could induce hardiness earlier than that which occurs in the controls.

Mayo et al. (1977) suggested that seasonal changes in blue light might trigger physiological changes in arctic species. Johnson and Salisbury (1967) found a marked decrease in the red:blue light ratio at sunset. Therefore, a blue poor regime was established to check if onset of hardiness might depend on the detection of changes in the red:blue ratio.

Biebl (1967) artificially darkened arctic plants during the summer to simulate 8 h days, and demonstrated a slight hardiness increase in *Betula nana* leaves. A third treatment, short days, was established to test for the same response in the present two species. Also, the treatment allowed the response of the study plants to be compared to the well-known effects of short days on temperate woody species.

To allow the separation of any phytochrome-mediated effects from those resulting from reduced photosynthesis and possibly starvation, a neutral density filter was used over one set of plants which passed all wavelengths equally, but reduced total PAR³ by approximately the same amount as the other filter treatments.

Through the above approach it was hoped that a better

³PAR: photosynthetically active radiation (400-700 nm).

understanding of cold acclimation in arctic regions would be gained.

II. Materials and Methods

A. Plant materials

Salix arctica Pall. and *Saxifraga oppositifolia* L. were obtained from Truelove Lowland, Devon Island, NWT (75°33'N, 84°40'W) during the summers of 1978 and 1979 for use in both the field and controlled environment aspects of this study.

The plants used during the 1978 season were located along the cushion plant-moss community as described by Muc and Bliss (1977). Saxifrage brought back to the University of Alberta for controlled environment work, was obtained from the same area, while willow was collected from the immediately adjacent hummocky sedge-moss meadow (Muc and Bliss 1977). Where possible, the original soil was retained with the plant, and sterile sand was added supplementally.

After transport to the University of Alberta, the potted plants were immediately placed into a +3°C chamber with continuous darkness, while a hardening off regime was prepared. After 6 days, the plants were transferred to a controlled environment chamber (Environmental Growth Chambers) and maintained under 5°C for 8 h and -1°C for 16 h d⁻¹. An 8 h photoperiod was given with the 5°C temperature period. The plants were removed after 12 d to a continuous -4°C regime in darkness, and one month later transferred to a -10°C continuous darkness chamber until dehardening 6.5 mon later.

Plant material collected in 1979 was obtained from within and around the study site of 1978.

B. General Materials and Methods

1. Cold hardiness technique

a. Temperature stress.

Leafy stem sections of *Salix arctica* and shoot tips of *Saxifraga oppositifolia* were tested for cold hardiness by subjection to a gradual lowering of tissue temperature at a rate of 4°C h^{-1} . Tissue samples from both species were separately wrapped in moist cheesecloth to prevent supercooling, and further sealed in aluminum foil to avoid dehydration (McKenzie and Weiser 1975). Fine wire thermocouples (ca. 0.3 mm diameter) were wrapped with samples to monitor changes in temperature. Each aluminum wrapped packet was placed in a separate 20 x 150 mm test tube which was immersed in a 5°C ethanol-filled Haake FK2 temperature circulator (Haake Inc.). Power was supplied by an Onan 5 kW diesel generator. The 1979 material was stressed using a Polytemp model 90C temperature circulator (Polyscience Corp.). The bath temperature was lowered through a motor driven gear assembly which provided a steady decrease in tissue temperature of 4°C h^{-1} . At 5° increments, one sample of each species was removed after being held at the desired temperature for at least 5 min, and immediately placed in a cool environment ($3-7^{\circ}\text{C}$) to thaw for 20 to 24 h. The range of temperature stress using the bath was between

+5 and -45°C.

b. Stress evaluation.

Survival temperature and, therefore, cold hardiness of the tissue was determined by applying a modification of the technique developed by Steponkus and Lanphear (1967). Tissue samples from each stress temperature, weighing 50 ± 5 mg, were placed in 18 x 150 mm test tubes, and 3 ml of 0.6% (w/v) triphenyl tetrazolium chloride (TTC) in 0.05M Na_2HPO_4 - KH_2PO_4 buffer (pH 7.4) + 0.05% (v/v) wetting agent (Triton X) were added. Willow stem sections were cut to 2 cm or less and the outer bark slit when determined to be necessary to allow solution infiltration. Whole leaves and leaf sections of *Salix* and the shoot tips of *Saxifraga* were used to test non-woody material. After infiltration under vacuum for 5-10 minutes, the tissue was incubated at 30°C for 15 h. The TTC solution was drained off, the tissue rinsed once in distilled water and 7 ml of 95% (v/v) ethanol were added. The reduced dye was extracted by boiling leaf tissue for 5 minutes and woody material for 10 minutes. After cooling, each sample was brought to 10 ml with 95% ethanol and the absorbance at 530 nm was measured using a Spectronic 20 spectrophotometer (Bausch and Lomb). The above techniques were identical for both controlled environment and field situations.

The absorbance at each temperature treatment was expressed as a percentage of the absorbance of the control

(either 5 or 0°C) and plotted as a function of temperature (Fig. 1). To correlate TTC reduction with killing temperature, *Salix* stem sections (with attached leaves) and *Saxifraga* from each stress temperature were placed in sterile sand on a mist bench, and survivorship and growth were recorded over a 2 week period. These correlation tests were conducted subsequent to field studies, during the controlled environment phase of the study, since it was impractical to carry out the tests in the field. The *Saxifraga* cuttings were first treated with 0.3 % IBA (3-indolylbutyric acid), and both species were watered periodically with one quarter strength Hoagland's solution (Hoagland and Arnon 1938 in Salisbury and Ross 1978).

The results of the correlation tests with respect to *Salix* stem tissue are shown in Fig. 2. If 50% or more of the stressed stem sections were alive after 4 weeks, *Salix* was considered to have survived that temperature. As a result, the 70% absorbance value was taken to correspond with 50% shoot survival, and it was from this value that the survival temperature was interpolated (Fig. 2):

Some of the anomalous points may be a result of differences in survival temperature between first year shoots, and older woody shoots. This distinction (differential survival) was not noted until later in the tests.

The attempts to correlate TTC reduction in *Salix* leaf tissue with survival of the leaves attached to the stem

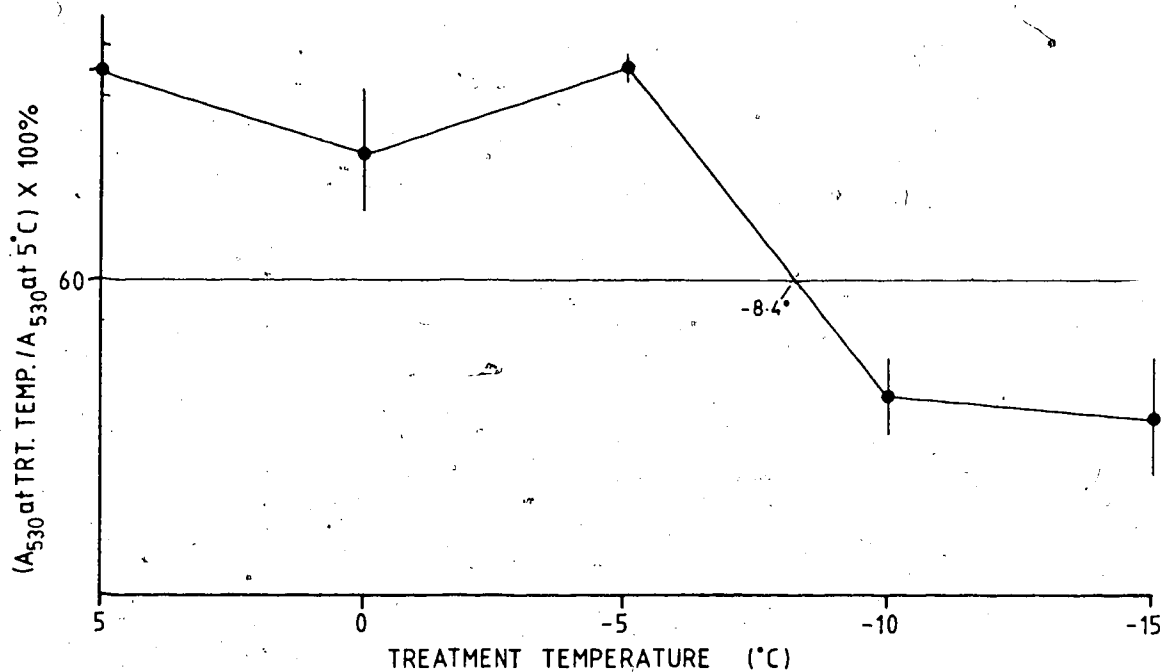

Fig. 1. The correlation between stress temperature and the reduction of triphenyl tetrazolium chloride (TTC) by *Salix arctica* leaf tissue. TTC reduction is expressed, for a given sample, as the percentage absorbance of light at 530 nm relative to the control sample (5°C). Vertical bars indicate standard error of the mean (n=3). The lethal temperature for *Salix* leaf tissue was found to be correlated with the 50% absorbance value, which in this case occurred at -8.4°C. The above test was conducted 17 July 1978.

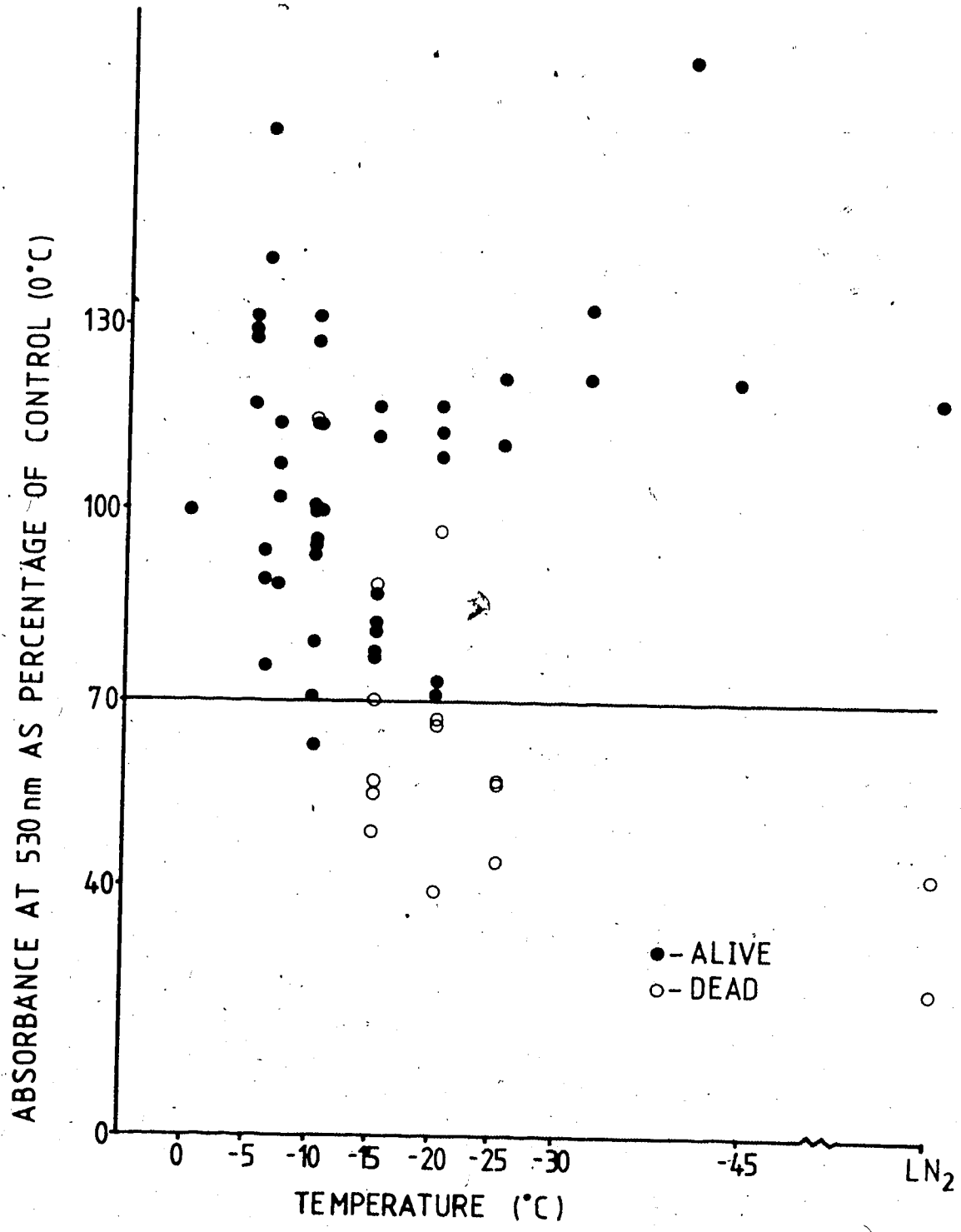

Fig. 2. Correlation between the post-freezing survival of *Salix arctica* stem tissue after 2 weeks in moist sand and the percentage reduction of TTC.

sections were unsuccessful. In all but one case, the leaves abscised soon after placement in the sand, including leaves from the control cuttings (5°C). In the latter case, the leaves remained somewhat longer than those stressed to lower temperatures, but still abscised much sooner than leaves from the same stem which later developed from buds and were retained for the life of the cutting. For this reason, a browning test, modelled after Davis (1980), was used as the primary standard against which TTC reduction was compared. This test was considered to be a reliable measure of post-freezing survivorship by Stergios and Howell (1973).

For this method, 7 mm diameter leaf disks were excised with a sharpened cork borer from previously stressed tissue, and floated on full strength Hoagland's solution within a 5 cm diameter Petri dish. Ten disks were used from each stress temperature. In most cases the remaining portion of the leaf was then used for the TTC test, as described earlier. After 7 days, dead tissue had turned a dark brownish-green, while healthy tissue remained as green as the unstressed controls. The disks were maintained under a 16 h/18°C:8 h/12°C temperature regime, at a continuous illumination of ca. 40 $\mu\text{E m}^{-2}\text{s}^{-1}$ PAR (400-700 nm). If 50% or more of the disks were alive after 7 days, the leaves were considered to have survived that temperature. These results were paired with the corresponding absorbance values from the TTC test to obtain a calibration of the TTC method as shown in Fig. 3. In this way an absorbance value corresponding to an LT 50

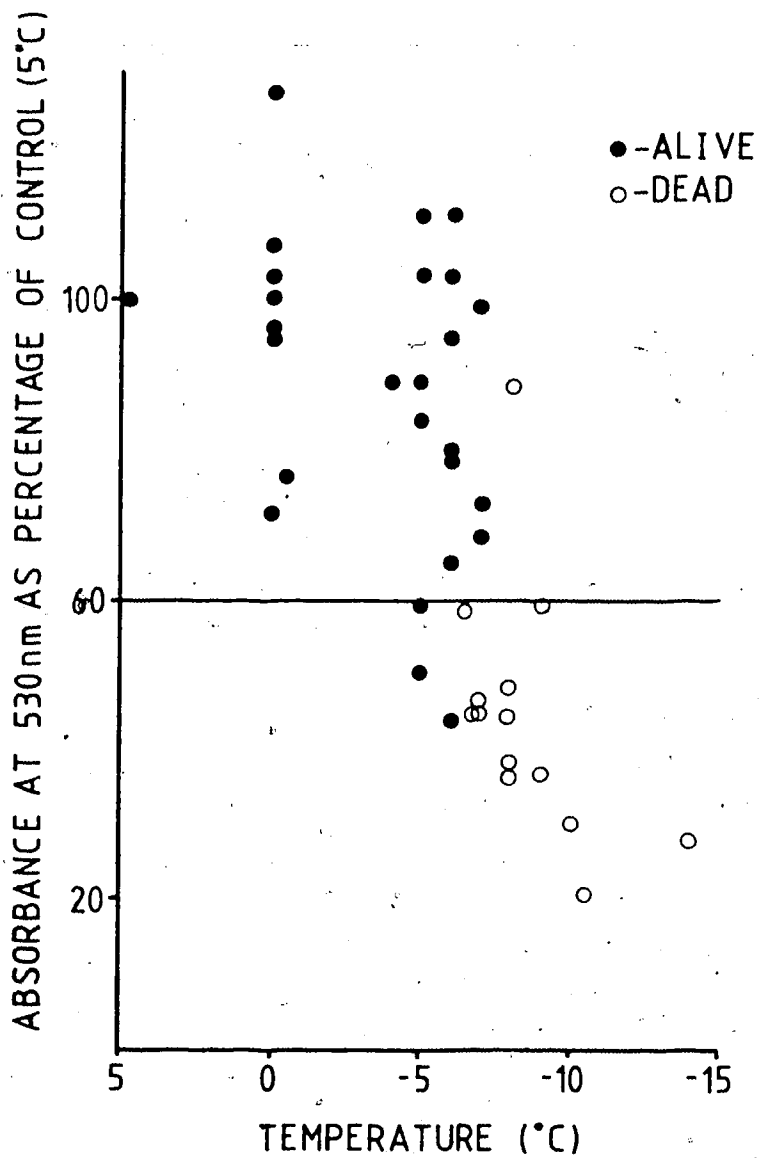

Fig. 3. Correlation between post-freezing survival of *Salix arctica* leaf disks after one week in Hoagland's solution and the percentage reduction of TTC.

(temperature at which 50% of the tissue is killed) was determined. Fig. 3 shows a fairly good correlation between the 60% reduction value and 50% or more survival of leaf disks after one week. Tissue with absorbance values greater than 60% of the control generally survived the effects of the cold treatment for at least a week, while those with values below 60% were viable at the time of the assay, but died during the following week. Thus, the 60% reduction value was taken as the killing point of *Salix* leaf tissue.

Saxifraga was able to be rooted much in the same way as *Salix* stem sections. Fig. 4 shows the results of the TTC-rooting correlation tests. The 60% reduction value was chosen to correspond with post-freezing survival of 50% of the cuttings after 2 weeks. The results of this correlation test were not as conclusive as desired. During sampling only the terminal bud and surrounding live leaves were used in the TTC test, while survivorship of the cuttings was assessed by evidence of any sign of new growth from the shoot or maintenance of health of the terminal bud. Hence, the same shoots were not sampled for the TTC and rooting tests. In some cases, when the terminal bud of the cutting died, axillary buds grew and the cutting was considered alive. There is evidence from previous work (Kainmüller 1975, Larcher 1975) that cold hardiness varies between organs of *Saxifraga oppositifolia*. Thus, some problems can be expected when a sample of one portion of the shoot is used as an indicator of total above ground cold hardiness.

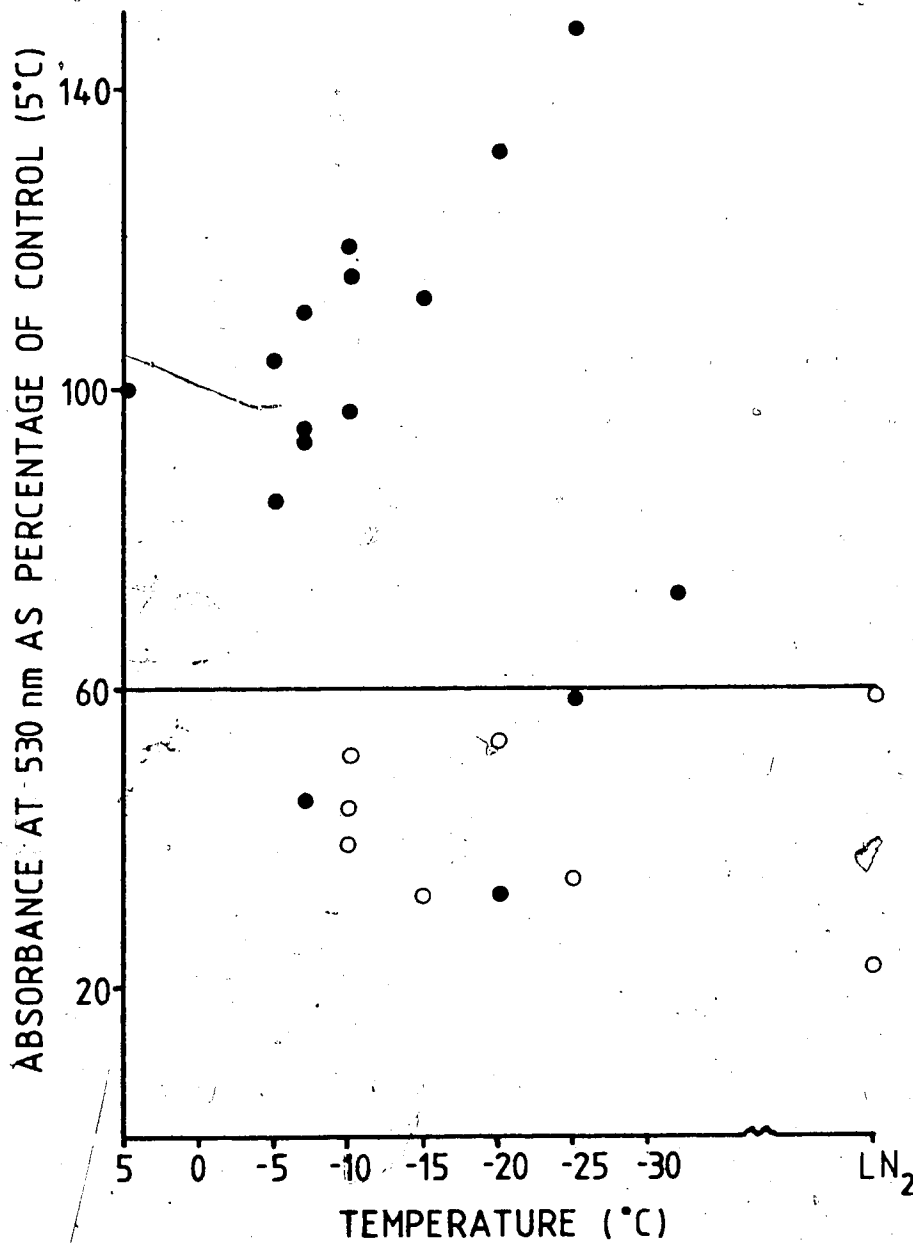

Fig. 4. Correlation between post-freezing survival of *Saxifraga oppositifolia* stem sections after 2 weeks in moist sand and percentage reduction of TTC.

2. Water relations

a. Thermocouple psychrometry.

Total leaf water potential (ψ_t) and the component potentials of turgor (ψ_p) and combined osmotic and matric ($\psi_{os} + \psi_m$) were determined using Spanner-type psychrometers modelled after Mayo (1974). A Wescor MJ55 psychrometric microvoltmeter was used to measure peak deflection after the application of a 20 s 8.0 ma current. One 5 mm diameter *Salix* leaf disk or a sample of 2-3 individual *Saxifraga* leaves was loaded into each 4.8 x 2 mm sample chamber and placed into a constant temperature bath to equilibrate for 5 or 6 h. Under field conditions, the temperature of the equilibration bath ranged between 5.0 and 12.5°C, with the rate of temperature change occurring very slowly. In controlled environment studies, the temperature bath varied slightly about 20°C. In both cases, replicate readings were taken 30 min apart until two values were within 0.1 μ volts in agreement. This was usually achieved within three readings.

During the controlled environment studies, component potentials were obtained by tightly wrapping the sample chambers with aluminum foil followed by immersion into liquid nitrogen (-196°C) for 10 minutes. The rapid freezing and thawing destroys membrane integrity and the pressure potential (ψ_p) goes to zero. After rewarming, the chamber was reloaded into the psychrometer and allowed to equilibrate for 5-6 hours. Since $\psi_t = \psi_{os} + \psi_m + \psi_p$, the initial

cell turgor pressure was obtained by $\psi_p = \psi_t - (\psi_{os} + \psi_m)$, where the combined osmotic and matric potential ($\psi_{os} + \psi_m$) obtained through the freeze-thaw treatment, is subtracted from the initial total water potential (ψ_t).

C. Field Studies

1. Site description

The field portion of this study was conducted during the summer of 1978 on Truelove Lowland, Devon Island, NWT (75°33'N; 84°40'W)(Fig. 5). The 43 km² lowland is bounded on the south and east by steep, 300 m high cliffs, and on the north and west by ocean. Truelove is one in a series of north coastal lowlands, all of which resulted from postglacial rebound after ice retreat. Deglaciation of Truelove Lowland occurred about 9450 yr B.P. (Barr 1971), and as a result of uplift, shallow lakes, formed by isolation of lagoons, and meadows (filled in lakes) are prevalent today. In addition, raised beach ridges occur in a regular sequence across the lowland, and provide much drier habitats due to their composition of coarse textured sands and gravels and slightly higher elevation (1 to >5 m). The ridges also impede drainage of lakes and meadows (Bliss 1977). Further information can be found in Bliss (1977).

Sedge-moss meadows comprise 41% of the lowland, while beach ridges total 11.4%. It is within these areas that *Salix arctica* and *Saxifraga oppositifolia* are most commonly found. Details of the plant communities occurring on the

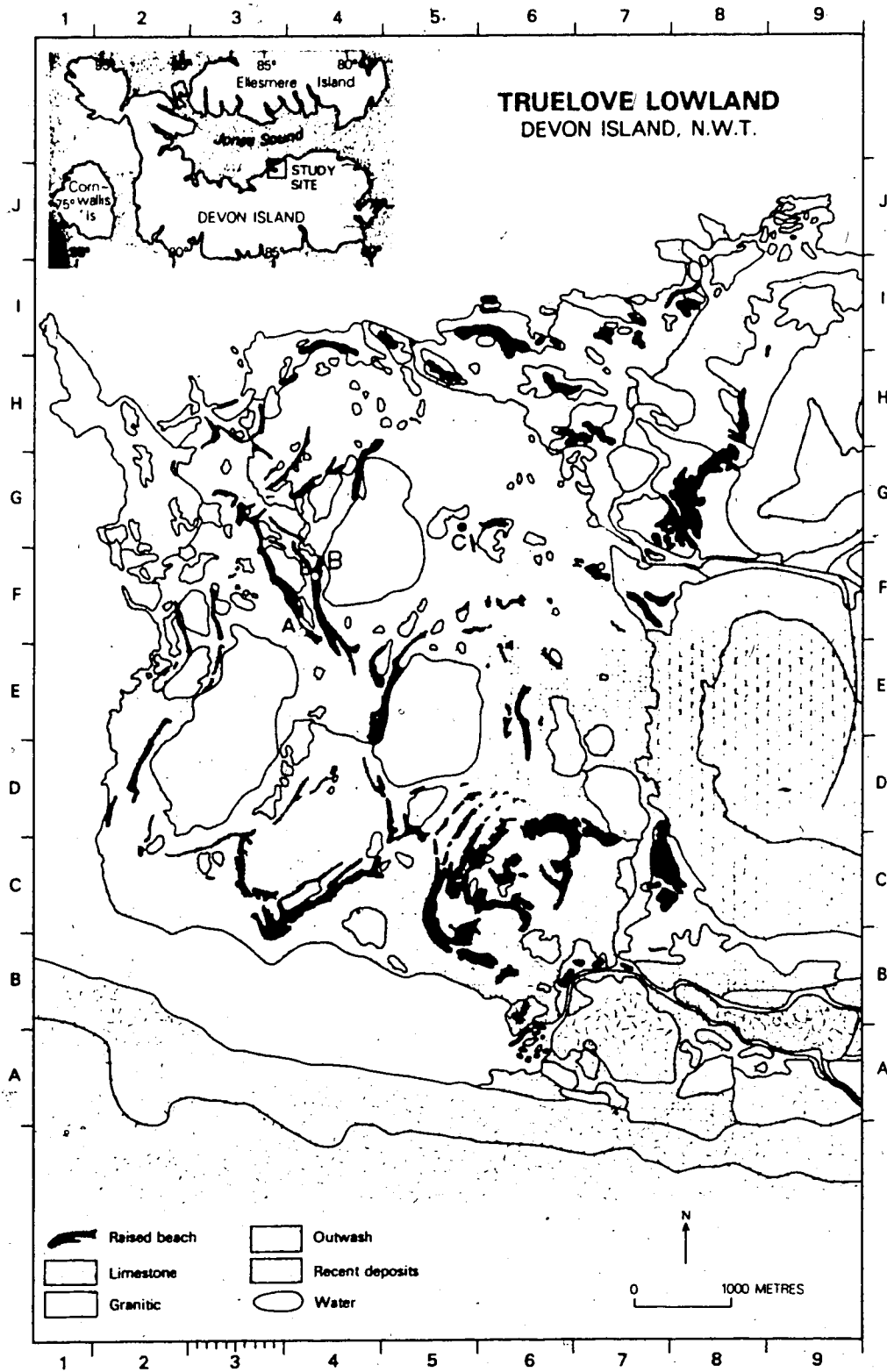

Fig. 5. Location of (A) the 1978 field site, (B) Base Camp and (C) the I.B.P. Intensive Raised Beach site on Truelove Lowland, Devon Island.

lowland can be found in Muc and Bliss (1977). Of importance here, is only how the distribution of the two species is related to the major community types. Although, *Salix arctica* is not a dominant component of any plant community, it is found commonly throughout the lowland, ranging in habitat from scree slopes to hummocky sedge-moss meadows. In the latter, willow is commonly limited to the hummocks which are elevated above the wetter hollows. *Saxifraga oppositifolia* is generally absent from meadows and wetter areas, but is very common in cushion plant-lichen and cushion plant-moss communities found along the crests and upper to lower slopes of raised beach ridges. Here it may codominate with *Dryas integrifolia*, and *Salix arctica* is also common (Muc and Bliss 1977). The local abundance of *Salix* and *Saxifraga* on beach ridge slopes made these areas a natural choice for the study of the two species.

The study site was 0.7 km SW of base camp (Fig. 5) and located along the midslope and slope base of a west-facing beach ridge. On 3 July, plants just beginning growth were chosen and the experimental treatments established. Fifteen individuals of each species were selected, with 3 plants of each species subjected to one of the five treatments. The 30 plants were spread 30 m along the length of the beach ridge and 15 m from slope base to midslope.

2. Experimental treatments

Three types of light filtering regimes were

established. Fig. 6 presents the quantum flux density as a function of wavelength for the two regimes which altered light quality. There is a relatively steady increase in quantum flux in unfiltered sunlight with increasing wavelength, and the red:far-red ratio⁴ (R:FR) (660:730 nm) is 1.00. The red:blue ratio (660:450) is 1.56. Under the red colored filter (Cinetuf #722 Deep Amber, Strand Century) essentially all of the blue light (400-500 nm) was eliminated, while a R:FR ratio of 1.00 was maintained. Between 400-730 nm, transmittance through this filter was 49% of full sunlight. This was termed the -blue (minus blue) treatment.

The -red treatment consisted of a blue filter (Cinetuf #763 Pale Blue) which passed most of the blue light, but significantly decreased the R:FR ratio to .62. Transmittance was 59% of full sunlight between 400 and 730 nm. A QSM-2500 quantaspectrometer (Tehtum Instruments) was used for the quantum flux determinations under clear sky conditions on 19 May 1978 between 1400-1500 h CST.

A third regime involved the use of two layers of cheesecloth as a neutral density (ND) filter. This resulted in a uniform reduction in sunlight transmittance across the visible light range, with a total transmittance of 63% of full sunlight. This regime was established in the attempt to separate any phytochrome mediated effects from those resulting from reduced photosynthesis.

⁴zeta will be used throughout when referring to the red:far-red ratio

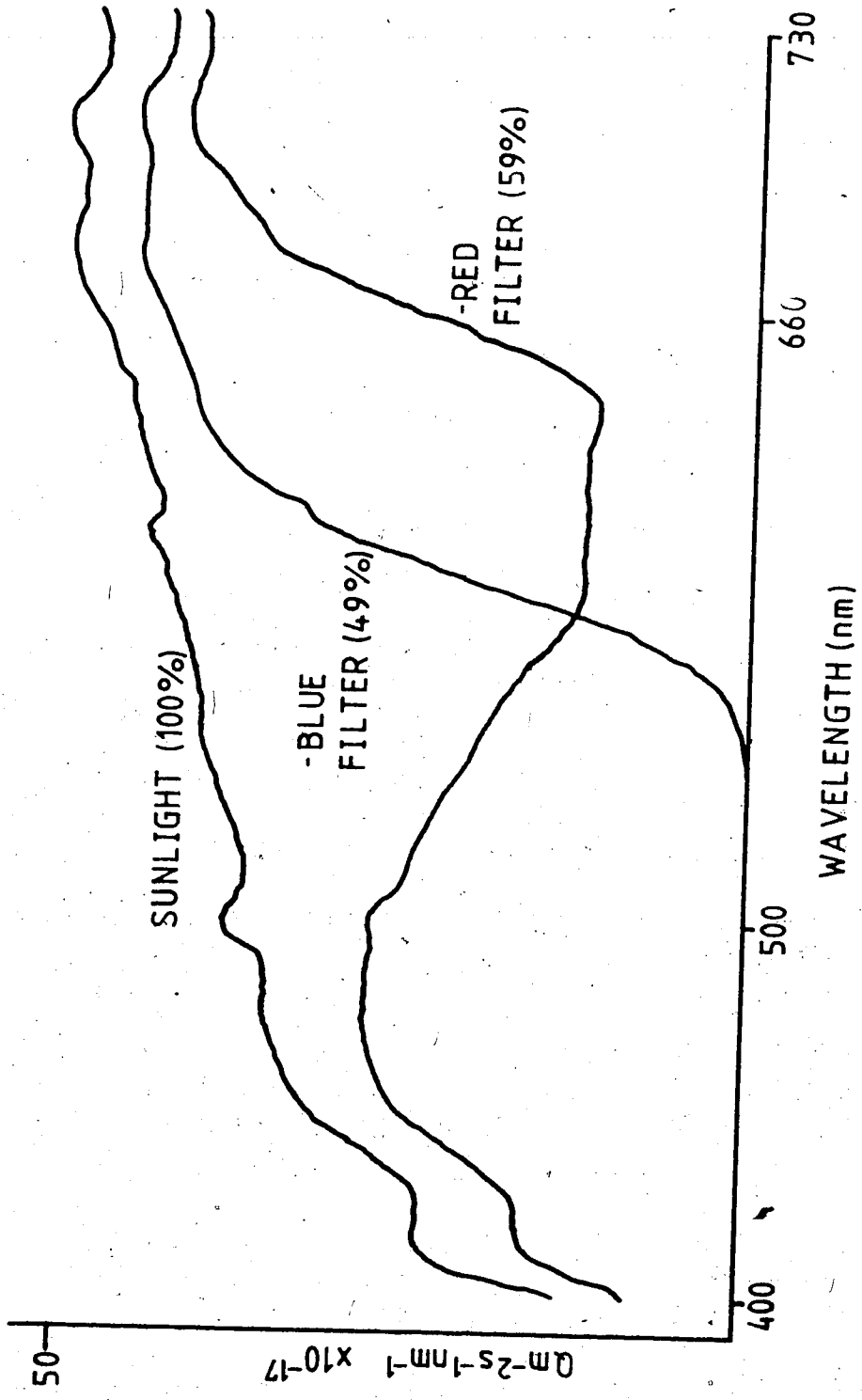

Fig. 6. Transmittance characteristics of the red and blue filters between 400-730 nm. The percentage of total radiation transmitted by each filter is given in parentheses. Full sunlight is shown for comparison.

The above treatments were applied by placing a 32 cm diameter Plexiglass dome over each plant with each dome receiving an external layer of the appropriate filter material. As shown in Fig. 7, a single sheet of the Cinetuf filter was pressed against the dome surface and held fast with epoxy. Each dome was suspended between 5-10 cm above the plant to allow air movement and to reduce the greenhouse effect. To guard against unfiltered light penetration at low sun angles, side shields were erected where necessary. The neutral density filters were constructed by epoxying 2 layers of cheesecloth to the internal surface to avoid soilage of the white surface. The treatments were initiated 2-3 July 1978.

The fourth treatment was one of shortened daylength (SD). An 8:16 h day:night cycle was established on 7 July 1978 through the daily covering and uncovering of the plants at 1700 and 0900 h CDT. The bucket arrangement shown in Fig. 8 was secured using metal stakes and a heavy rock on top, and insured against light penetration. The large foil covered bucket helped avoid internal heat buildup, while the black surface of the inner bucket reduced internal reflections of any penetrating light.

A fifth set of plants served as a control and were untreated, but sampled as often as the other plants. The treatment and the control plants were situated within the site as shown in Fig. 9.



Fig. 7. A representative Plexiglass dome and color filter used to alter the light regime of the underlying plant. The dome was raised slightly to allow air movement, and side shields were erected when necessary to avoid unfiltered light penetration at low sun angles.

COLOURED PICTURE



Fig. 8. Bucket arrangement used to artificially shorten days. The inner small black pail attenuated internal light reflections, while the larger foil covered pail reduced heat buildup.

COLOURED PICTURE

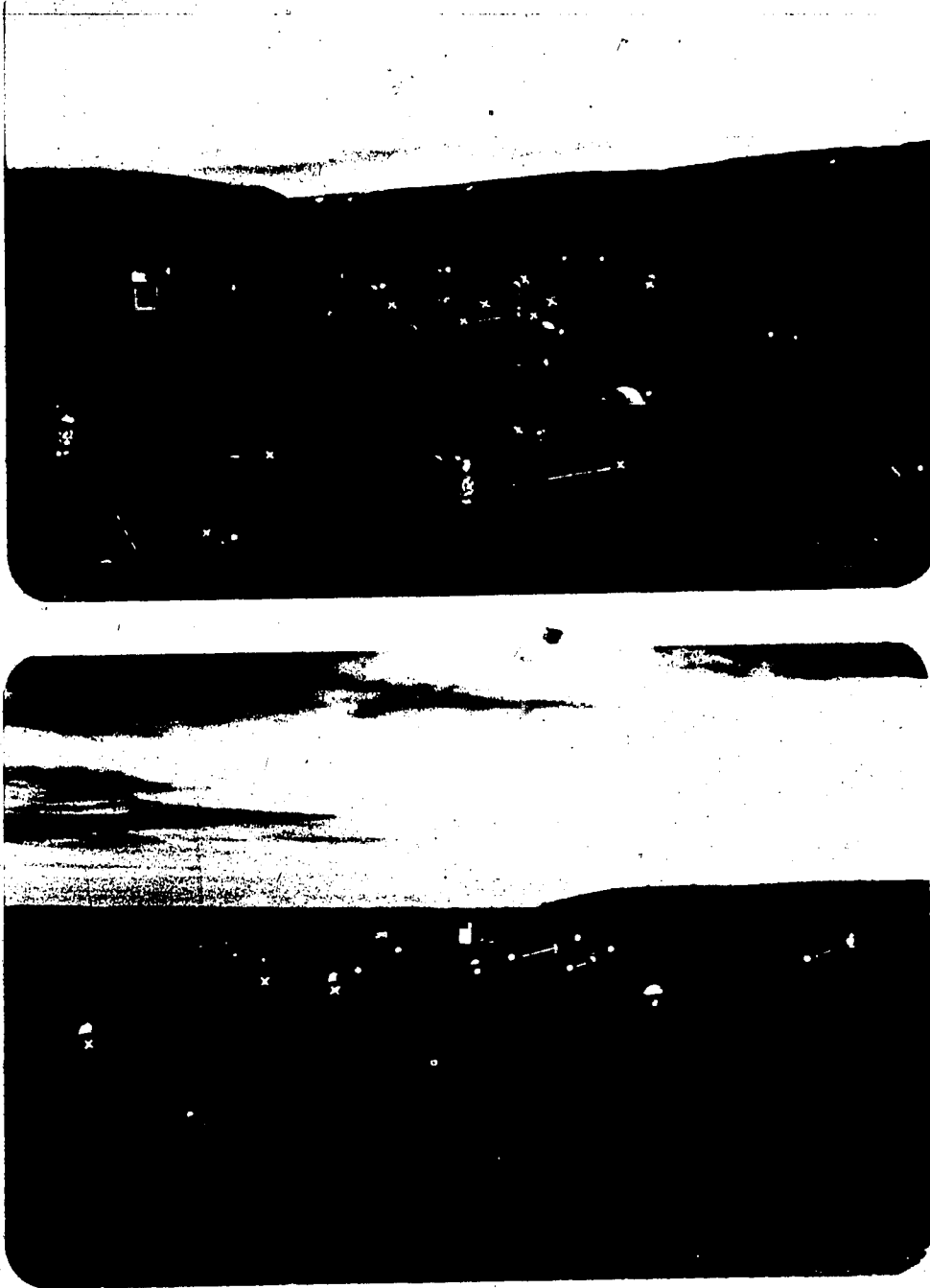

Fig. 9. Arrangement of treatments within the study site. White dots indicate *Saxifraga oppositifolia* plants and white crosses mark *Salix arctica* plants. Lines associate short day plants with their covers. Upper photo taken looking southeast; lower photo is towards northwest.

3. Phenology

A qualitative record of plant phenology was kept for all treatments during the 1978 season. Every second day each plant was observed and the following features were noted when applicable: occurrence of bud break, date of full leaf expansion, shoot expansion, anthesis, leaf senescence and fruit development.

Full leaf expansion in *Salix arctica* was taken to be when no further changes in leaf size were evident. With *Saxifraga oppositifolia*, extension of the growing shoot tips occurred after the tips greened up, and the dates of both events were recorded. Leaf senescence, for both species, was defined as the first sign of leaf yellowing. Anthesis in both species was taken to be when anther dehiscence was evident or, in the case of *Saxifraga*, when the flowers were fully open. Fruit development was only recorded for willow, and was defined as the date when the swelling of pistils began. In all of the above, the average date for each event is reported based on the three replicates per treatment.

4. Environmental measurements

a. Radiation.

Total incoming shortwave radiation (280-2800 nm) was recorded between 3 July and 21 August 1978 with a Robitzsch bimetallic strip actinograph (Belfort Instrument Co. Model 51850). To obtain information on the relative changes in red (660 nm), far-red (730 nm) and blue (400-500 nm) light

throughout the season and on a daily basis, three special light sensors were constructed. All were designed using a cosine-corrected sensor head with a diffusing filter as outlined by Kerr, Thurtell and Tanner (1967). A Sharp silicon blue cell SBC-2020 (Sharp Electronics Corporation) with maximum sensitivity around 560 nm was used as the primary light sensing element. To obtain a narrow waveband response centered in the red portion of the spectrum, a narrow band interference filter with a nominal peak transmittance of 40% at 664 nm and a half peak height bandwidth of 11 nm was placed between the diffusing disk and silicon blue cell. In the same way, a far-red sensor was obtained with a narrow band interference filter with a peak transmittance of 40% at 729 nm and a half peak height bandwidth of 9 nm. The blue sensor used a broad band interference filter with peak transmittance of 75% at approximately 460 nm, with a half peak height bandwidth of about 55 nm. The transmittance characteristics of this filter are shown in Appendix 1a. All three interference filters were purchased from Rolyn Optics Co. The internal design of the sensors is shown in Appendix 1b.

A quantum sensor (Lambda Instruments Corp.), receptive to the 400-700 nm waveband, was used to obtain spot readings of photosynthetically active radiation. The three specialized light sensors were also used on a spot reading basis throughout the season.

b. Temperature, humidity and precipitation.

A hair element type hygrothermograph (Belfort Instrument Co. Model 5-594), placed at ground level within an aluminum louvered shelter, recorded air temperature and humidity at the study site on a continuous basis from 1 July to 21 August 1978. Once a day the hygrothermograph was calibrated against a sling psychrometer. Precipitation was recorded at base camp, 0.7 km NE of the study site, with a Taylor Clear-Vu rain gauge.

Daily monitoring of air, leaf and soil temperatures of a representative plant from each treatment, for both species, was conducted throughout the season to determine whether the four experimental conditions were affecting the microenvironment of the test plants in ways other than the intended shifts in light quality, intensity or duration. Soil temperatures at 0 and -5 cm were measured using thermocouples (sensor diameter ca. 2.5-3.0 mm). The thermocouples were read at least once daily with a microvoltmeter and electronic reference junction (Wescor Instruments Model MJ55). At the same time, air temperature 10 cm from the ground surface was recorded from a thermocouple (sensor diameter ca. 1.0-1.5 mm) shielded from direct radiation by a whitened aluminum shield. A third set of thermocouples was used to measure leaf temperature. Three thermocouples (sensor diameter ca. 0.25-0.30 mm) were connected in parallel and attached to three different leaves on the plant to obtain an average leaf temperature. The leaf

thermocouple clips were modified after Fry (1965) and described by Addison (1973). The soil, air and leaf thermocouple temperatures were all recorded within a few minutes of each other for any given plant.

c. Wind.

To determine the effect of the presence of the Plexiglass domes on wind velocity at the plant level, a hot wire anemometer (Hastings-Raydist Model RB-1) with an omni-directional probe was used to compare dome wind velocities inside and outside the domes. Ten readings were taken 10 s apart to prevent bias during periods of variable wind speed. The tests were conducted by placing the probe beside the plant under the dome for the first 10 readings, and at the same level outside the dome for another 10 readings. In some cases the outside values were collected first. The distance between the first and second set of readings was usually between 30 and 40 cm. In the few instances where the wind velocity shifted markedly between the two sets of readings resulting in an obvious difference between the data sets independent of the dome presence, the sampling was repeated.

d. Soil.

The soil was described by Walker and Peters (1977) as a Brunisolic Static Cryosol. Soil moisture was determined

gravimetrically on a weekly basis, both under and beside the treatment domes to assess the effect of their presence on water availability. Domes under which soil sampling occurred were not used for plant sampling. Because of the stoniness of this soil, the larger stones and pebbles were arbitrarily removed before the final soil dry weight was determined. This was done to avoid unrepresentatively low values which would result from the stones. These are physiologically "dry" areas of mass and volume from the point of view of utilization by the plant. The sample depths ranged between the top 4 and 7 cm. Samples were dried at ca. 90°C for ca. 36 h.

The active layer was measured daily until depth exceeded 30 cm. Since the study site was located between the midslope and foot of a beach ridge, the daily position of the receding snow front was recorded along with active layer depth.

5. Sampling frequency

Successful cold hardiness tests were conducted in the field between 17 July and 16 August 1978. *Salix* leaf tissue from all treatments was sampled weekly throughout this period, and stem tissue was sampled biweekly from 31 July to 16 August. Due to limited amounts of plant tissue, *Saxifraga* was only sampled three times; on 24 July and 7 and 14 August.

Water potential of *Salix* and *Saxifraga* leaf tissue was

etermined every 3 to 7 days from between 4 July and 17 August. A single *Salix* leaf disk, or sample of 2 to 3 *Saxifraga* leaves was loaded into the psychrometer sample chambers, sealed and returned to base camp to equilibrate in a water bath. Four samples from each of the 5 treatments were taken per species. Sampling of the two species was on alternate days due to a limited number of psychrometers.

D. Controlled Environment Studies

1. Experimental treatments

Characteristics of the experimental and control regimes are shown in Table 1. *Salix* and *Saxifraga* plants were dehardened from -10°C by 4 days at -3°C in darkness, followed by 3 days at 1°C and continuous illumination (ca. $200 \mu\text{E} \cdot \text{m}^{-2} \cdot \text{s}^{-1}$). All plants were maintained under control conditions (Table 1) for 25 days until leaf expansion was completed in *Salix*. Four plants of each species were then transferred to one of three experimental treatments. Studies of cold hardiness and water potential were conducted with these plants for 35 days and subsequently rehardened and stored at -3°C .

Fig. 10 shows representative spectra from each of the regimes. For the control, short day and far-red (day) regimes, a combination of cool white VHO fluorescent lamps (1500 ma) and 60 W incandescent bulbs were used along with 400 W high pressure sodium lamps and 400 W metal halide

Table 1. Characteristics of experimental and control growth regimes used in the laboratory studies of *Salix arctica* and *Saxifraga oppositifolia*.

Treatment	Air Temperature			PAR ($\mu\text{E m}^{-2}\text{s}^{-1}$)	R:FR ratio		
Control	15 h 10°C	6 h 3°C	3 h transition	15 h 500-520 (590)?	9 h 190-220	15 h 1.62-1.73	9 h 1.36-1.49
	15 h 10°C	3 h 3°C	3 h -2°C	15 h 490	9 h 200		24 h 1.65
Far red night	15 h 12°C	5 h 4°C	4 h transition	15 h 490	9 h ca. 20	15 h 1.73	9 h 0.57
	15 h 10°C	6 h 3°C	3 h transition	15 h 500-520 (590)?	9 h 0	15 h 1.62-1.73	

PAR: photosynthetically active radiation (400-700 nm)
 ? : indicates isolated extremes

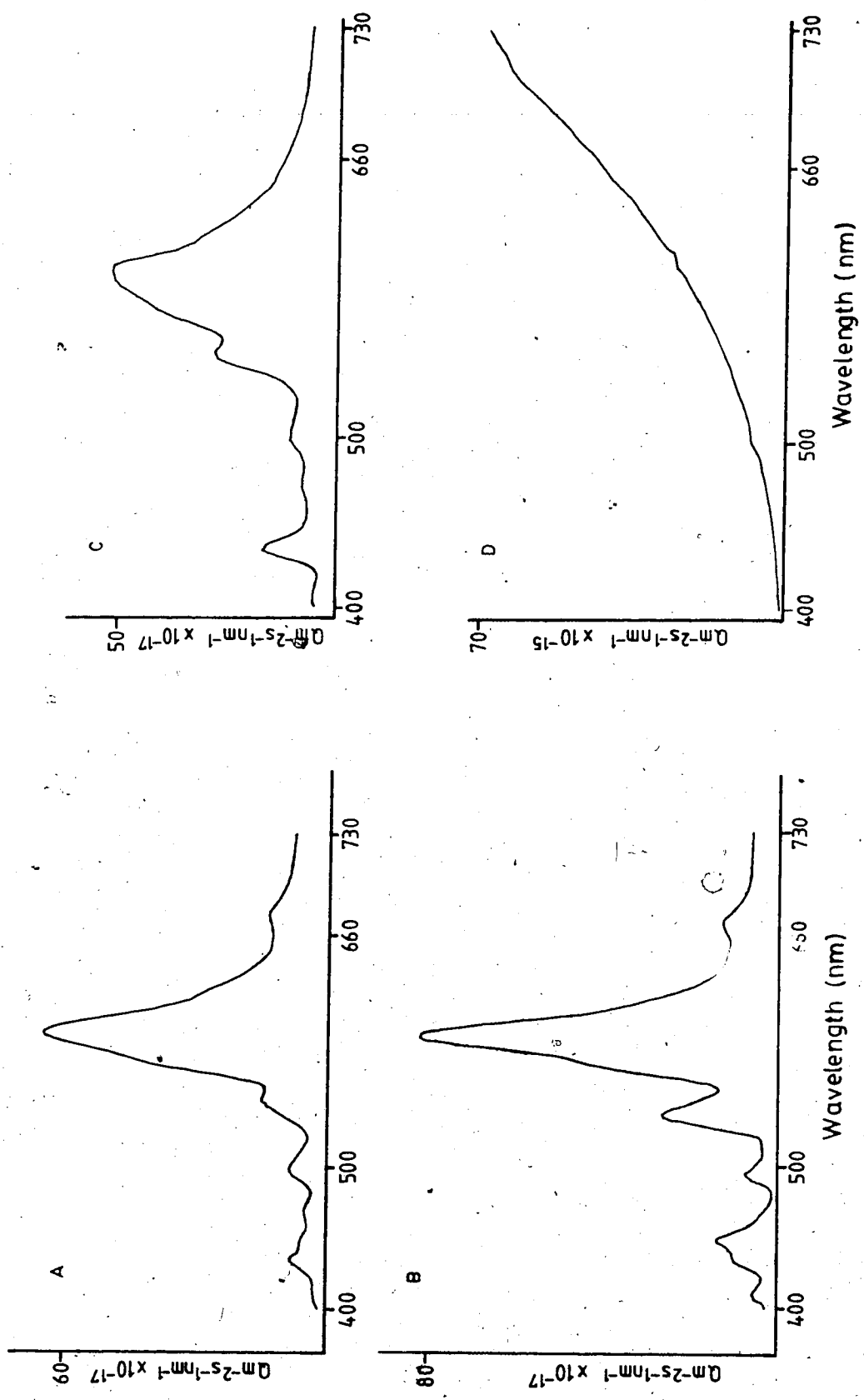

Fig. 10. Representative spectra of the growth chambers used in the laboratory treatments outlined in Table 1. A= control and short day; B= frost treated; C= far-red (day); D= far-red (night). Note changes in scale.

lamps. With the exception of fluorescent lights, the same lamp types were used in the frost regime. Incandescent bulbs created the low red:far-red ratio for the far-red (night) conditions.

2. Sampling frequency

The cold hardiness of *Salix* and *Saxifraga* was tested at 2 week intervals for 4 weeks before beginning the experimental treatments. Two additional tests were conducted during the treatment period before rehardening and storage. Fresh plant material from near the 1978 study site became available at this time and 3 cold hardiness tests were conducted before rehardening. These latter plants were continuously maintained at 5°C and continuous illumination.

Water potential of *Salix* and *Saxifraga* was monitored weekly or biweekly during the 2 month period of plant activity. A minimum of 4 samples from each of the 4 treatments was taken per species. Sampling of the two species alternated because of a limited number of psychrometers.

III. Results and Discussion

A. Environmental Characterization of Field Site

1. Radiation

Figure 11 presents five day means of the seasonal variation in global radiation during the 1978 field season. In comparison, the base camp data from 1971-1973 (Courtin and Labine, unpublished data) indicate that the available short wave radiation in 1978 was not unlike previous years. As the season progresses, a general reduction in radiation is evident in all cases. This is to be expected past the summer solstice, as the sun occurs increasingly lower in the sky. The between year variation is largely a function of cloud cover, which in turn has been suggested to be dependent on time of snowmelt over the land and the breakup of sea ice (Courtin and Labine 1977). Even with the expected yearly variation in cloud cover, the 1978 season fits well among the results of the previous years. The tendency toward slightly lower values may be a result of the use of an Eppley black and white pyranometer (Model 8-48) in the collection of the 1971-1973 data, which was situated at the base camp (Courtin and Labine 1977) 0.7 km from the 1978 field site (Fig. 5, p. 28). Although the distance between the sites is probably insignificant, the Eppley pyranometer is more sensitive to low intensity radiation than the actinograph and this would tend to result, on the average, in slightly higher amounts of recorded shortwave radiation.

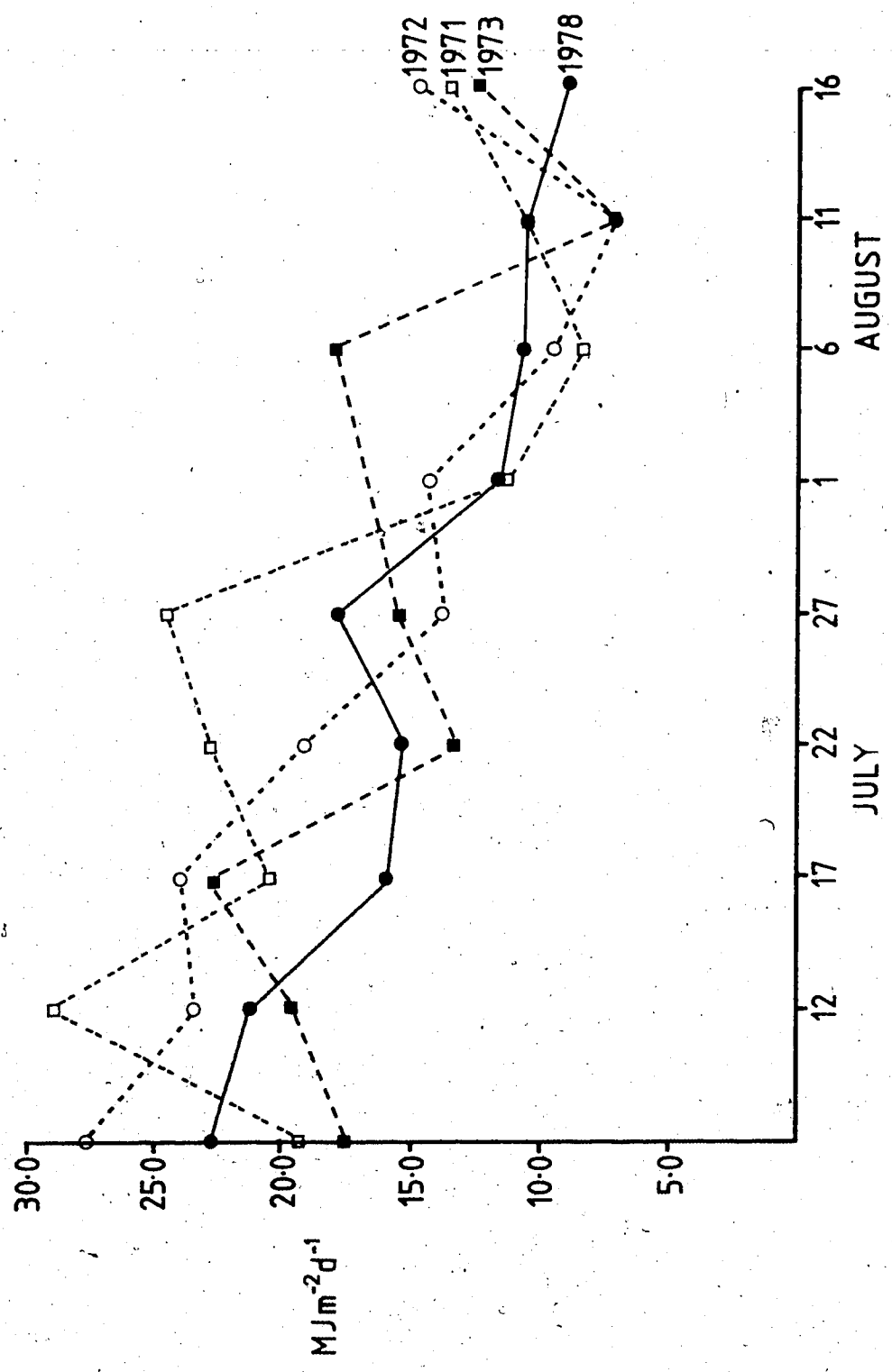

Fig. 11. Total global radiation (280-2800 nm) recorded at the 1978 field site and presented as 5 day means. Base Camp data from 1971-1973 are shown for comparison (Courtin and Labine unpub. data).

Taking this into account would move the 1978 data into even closer alignment with the previous years.

From Figure 11 one can obtain an estimate of the amount of photosynthetically active radiation (PAR) received by the plants. Various authors have determined the ratio of PAR to global radiation to be between 0.47 and 0.50 (Szeicz 1974, Stanhill and Fuchs 1977, Addison and Bliss 1980). These values are remarkably constant over a wide range of latitudes (12°N - 77°N) and atmospheric conditions, with most variation resulting from changes in atmospheric turbidity and water content. In addition, overcast skies result in slightly higher (0.51-0.52) ratios due to infrared attenuation, and low sun angles (solar elevation $<10^{\circ}$) also tend to produce slightly larger ratios, probably a result of an increased diffuse radiation component (Szeicz 1974).

Therefore, a value of 0.50 can conveniently be applied to the data in Figure 11, and, since the relative position of each year will remain the same, one can conclude that the amount of PAR available in 1978 was very similar to previous years.

There is some evidence that diurnal fluctuations of zeta (R:FR ratio) occur in a regular manner (Figs. 12 and 13). From 21-29 July zeta ranged from 0.90 to 1.20, with the majority of values less than 1.00 occurring between 2200 and 0100 hr CDT (Fig. 12). Since the population variances were too different, zeta values between 2200 and 0400 hr were compared to the values between 0800 and 1800 hr using the

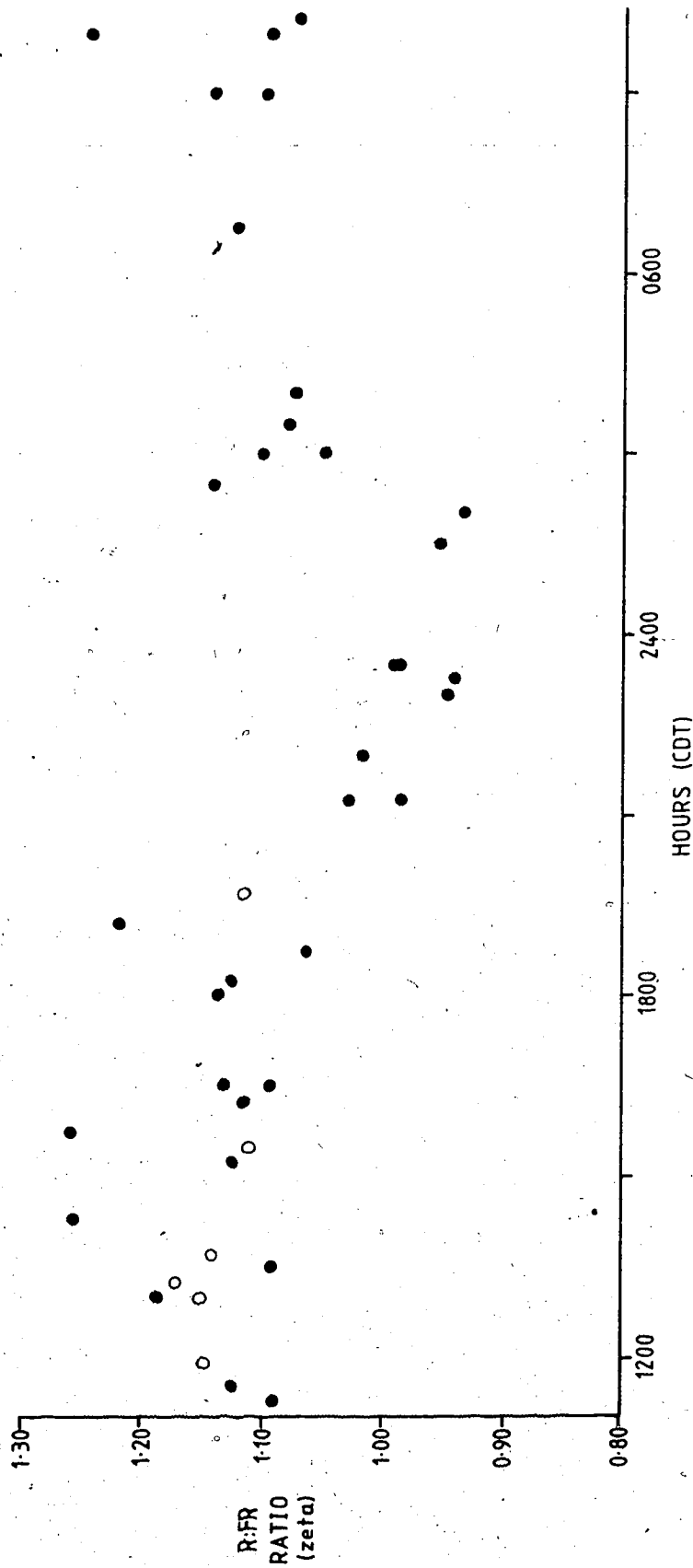

Fig. 13. Measured diurnal variation in zeta between 29 July and 22 August 1978. One anomalous direct beam (○) reading at 2030 h has been omitted. Most measurements were made under overcast or obscured sun conditions (●).

Mann-Whitney test (Conover 1971). The "night" readings were significantly different ($p < 0.01$). A clearer example was seen between 29 July and 22 August (Fig. 13). No values above 1.00 occurred between 2200 and 0200 hr and from 0300 to 2100 hr all readings were greater than 1.05. The mean R:FR ratio between 2100 and 0500 hr (1.02) was compared to the mean value between 0900 and 1700 hr (1.14) using the t-test (Dixon and Masse 1977). The two samples differed very significantly ($p < 0.01$). Thus, coincidence of minimum zeta values with minimum solar elevations is clear.

The great majority of the data are from overcast or obscured sun sky conditions, since cloud cover was most frequent near the end of the season. In addition, these conditions eliminated concerns regarding the cosine response of the sensors at low sun angles, as deviations from Lambert's cosine law were increasingly significant at solar elevations less than 10-15° (Fig. 43; Appendix 2). Difficulties in calibrating the sensors to correct for these deviations resulted in uncertainty in the soundness of direct solar beam values at low sun angles. Therefore, these values were omitted from both of the above figures.

Some workers at arctic (Teeri 1974, 1976) and temperate (Holmes and Smith 1977a) latitudes have raised the question of whether diurnal and/or seasonal variations in zeta can act as an environmental cue for certain physiological responses in plants. The above results suggest that during late July and August in the High Arctic, variations in zeta

do occur on a 24 hour cycle. However, whether the differences are of sufficient magnitude to elicit a response or whether seasonal shifts occur in zeta is unclear. The question in regard to magnitude will be considered later.

Due to the lack of early season data it was not possible to determine whether a seasonal shift in zeta occurred. However, a model allowing the calculation of spectral solar irradiance was used to determine whether a seasonal cueing mechanism could, theoretically, be in operation at arctic latitudes. As well, the model provided a check on the absolute magnitudes and relative daily shifts of zeta as reported in Figures 12 and 13.

The model (Leckner 1978) allows the calculation of the spectral distribution of solar radiation at the earth's surface, and takes into account the various scattering and absorptive phenomena. The details of the model and the application to the prediction of zeta values on Truelove are given in Appendix 3.

The results of the model suggest that diurnal variation in zeta near the end of the summer may be large enough to act as a photoperiodic cueing mechanism ($\Delta zeta = 0.27$) (Fig. 14). The large difference between the minimum zeta of 6 July and the minimum of 6 August results from an additional drop in solar elevation between the two dates of only 5°. The minimum solar elevation on 6 July is ca. 8° and for 6 August it is ca. 3°. This is supported by previous work which has found large zeta shifts corresponding to small changes in

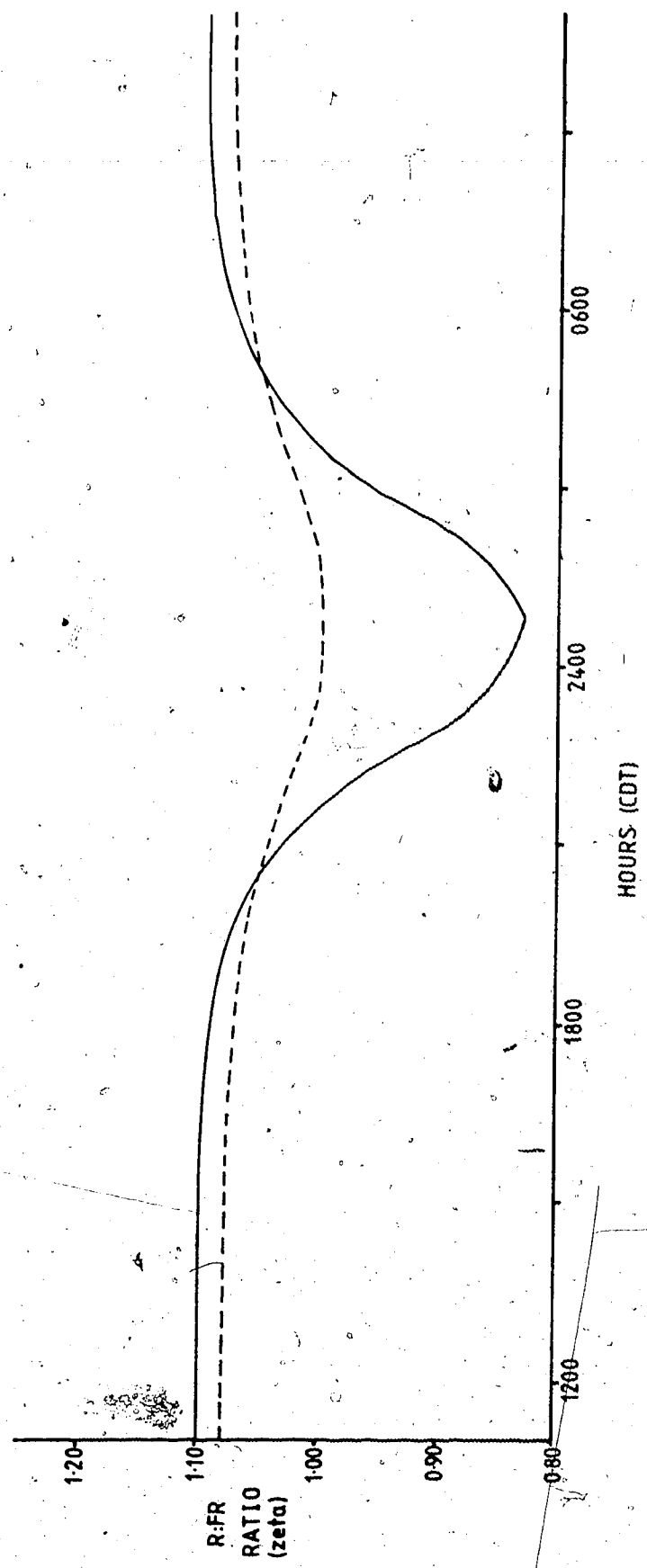

Fig. 14. Predicted diurnal variation in zeta at latitude 75°33' N, longitude 84°40' W on 6 July (---) and 6 August (—). Calculations are based on a model of clear sky diffuse and direct radiation (Leckner 1978). Variables of water vapor pathlength, ozone concentration and turbidity are as given in Appendix 3.

solar elevation near sundown (Holmes and McCartney 1976, Holmes and Smith 1977a)

There is the possibility, also, that the seasonal shift in zeta between July and August, most pronounced near 2400 h ($\Delta zeta=0.17$), is large enough to be used by plants as a photoperiodic cue.

Despite differences in sky conditions, the predicted red:far-red ratios are very similar to the measured values taken during August with regard to both absolute values and degree of diurnal variation (compare Fig. 13 and 14). The theoretical values range from 1.10 to 0.83 ($\Delta zeta=0.27$) while the August measurements fell between ca. 1.15 and 0.94 ($\Delta zeta=0.21$).

It is important to note that the majority of 1978 zeta measurements were made under conditions of obscured sun, while clear skies were assumed for the model. This latter assumption is unrealistic, since the mean monthly cloudiness at 75°N 80°W is 63% in July and 72% in August (Vowinckel 1962). The possible effects of overcast skies on zeta are considered in more detail in Appendix 3. In general, lower transmittance of 730 nm light would be expected due to weak absorption by cloud water at that wavelength (Gates and Shaw 1960, McCartney and Unsworth 1978). In addition, higher reflectance of 660 nm light from snow (Krinov 1953) and the subsequent reflectance from the clouds contributes to the occurrence of higher zeta under cloudy skies. The prevalence of red light absorbing sedges and grasses (Krinov 1953) on

the Lowland would mitigate somewhat the effects of the surrounding snow covered sea ice, but the net effect would likely still be a higher component of reflected red light. Therefore, greater zeta values than those predicted for clear skies would be expected, and this is what was found (compare Figs. 13 and 14). Errors in the assumptions of ozone concentration, turbidity and water vapor pathlength (see Appendix 3) as well as seasonal variations in these parameters, may also account for some of the discrepancy between actual and predicted values, and for the scatter in the radiation measurements.

The above results are not supported by previous high arctic work. Both Mayo et al. (1977) and Addison (1977a) concluded that diurnal and seasonal shifts in zeta on Truelove Lowland and King Christian Island were not large enough to be able to be used by plants as cues for flowering or, presumably, for cold acclimation. Addison (1977a) reported a maximum zeta shift of 0.10 on 6 August. Mayo et al. (1977) found similar results throughout the summers of 1971 and 1972, but the shifts were not consistently in the same direction. Both studies reported $\Delta zeta$ to be approximately one half of that found in 1978 ($\Delta zeta = 0.10$ vs. 0.21). Part of the discrepancy may be due to the use of the ISCO Spectroradiometer in the former studies for the measurement of 650 and 725 nm wavelengths. The cosine response of this instrument drops sharply with an angle of incidence $< 70^\circ$ from normal (Fig. 44; Appendix 2), resulting

in unrealistically low values. Although the response is very similar at both wavelengths, the reduction in the absolute magnitude of the readings may result in increased error when zeta is calculated, especially when data are recorded or rounded to the nearest integer, as was often done with the Truelove measurements. A difference of 1 unit when the measurements have values of 5 or 6 units is more significant than when the values are in the 50 or 60 range. In addition, a slight error in the angle of the sensor head relative to the sun could result in significant differences in zeta, due to the sharp drop in cosine response at low sun angles and due to the great dependence of zeta on slight changes in sun angle at low solar elevations.

Despite the differences between data, it is clear that the magnitude of zeta shifts is less in the Arctic than at lower latitudes. Measurements from latitude 52°N, during January, have shown a diurnal variation in zeta of ca. 0.50, more than twice the value found during August 1978 (Holmes and McCartney 1976, Holmes and Smith 1977a). Thus, plants at high latitudes would need to be very sensitive to small changes in zeta in order for a phytochrome based cueing mechanism to work. Evidence from other, unrelated, physiological work that this is possible is presented in the later section on treatment effects.

The nature of the diurnal shift in red:blue ratios is not clear, although there appear to be differences between low and high sun angles, as found with zeta (Fig. 15). These

results contrast with those predicted from the radiation model, (Leckner 1978; Appendix 3) which show a very marked increase in the red:blue ratio with decreasing solar elevation (Fig. 16).

At high solar elevations, the differences between the predicted and actual results are not major. Between 0800 and 1700 hr the predicted values range from 1.30-1.60, while during the same time, the actual measurements were between 1.45-1.70. The blue sensor recorded quanta from between 400-500 nm, while the median value of 450 nm was used for the model. The rapid decline in quantum flux density from 450-400 nm (Fig. 6, p. 31) may have resulted in 450 nm being too large of a wavelength to be representative of the 400-500 nm waveband. Hence, the predicted values would be too small.

The wide scattering of the Truelove data at low sun angles suggests that variations in cloud conditions had strong effects on red:blue ratios. This may have been due to different amounts of exposed blue sky and/or variable cloud thickness. In addition, at low sun angles much higher red:blue ratios were predicted than were obtained (maximum predicted=5.5; maximum obtained=2.0). As discussed in Appendix 3, assuming a spectral composition of the overcast sky equivalent to the diffuse component of the clear sky results in much smaller red:blue ratios ($R:BL=0.47-0.68$). With partly cloudy skies, this could result in lower red:blue ratios than under clear conditions. Also, a

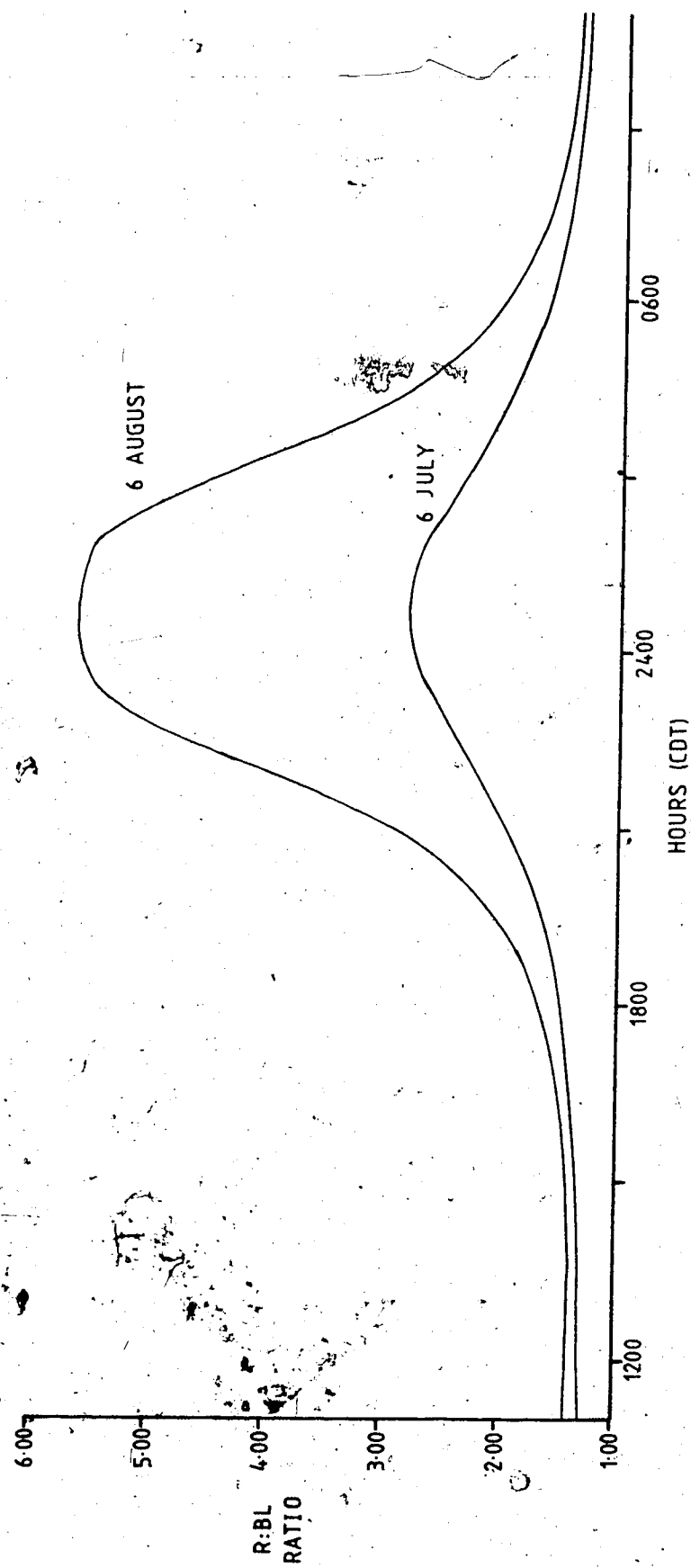

Fig. 16. Predicted diurnal variation in red:blue (660:450) ratios at latitude 75° 33' N; longitude 84° 40' W on 6 July and 6 August. Calculations are based on a model of clear sky diffuse and direct radiation (Leckner 1978). Variables of ozone concentration and turbidity are as given in Appendix 3.

prevalence of snow as the primary reflecting surface decreases direct beam red:blue ratios by a factor of 0.84 (see Appendix 3), and may also explain the lower ratios in comparison to the predictions.

Results similar to the predicted values have been reported from lower latitudes (Johnson and Salisbury 1967). Gates (1966) also showed the increase in the red:blue ratio with increasing air mass. There is some information which has implicated the interactions of red, far-red and blue light to be important in flowering, but actual red:blue ratios were not calculated (Brown and Klein 1971, Sawhney 1977a,b,c). The greater variation in red:blue ratios near 2400 hr during August suggests that the values are affected by very low sun angles. Whether the shifts are large enough or regular enough, as suggested by the model, to provide plants with a potential cueing mechanism remains unclear.

2. Temperature and Vapor Pressure Deficit

The seasonal variation in air temperature is presented as five day means and shown in Fig. 17. Along with the 1978 data are the results of measurements from 1970-1973 obtained from the Intensive Raised Beach study site of the I.B.P. (Courtin and Labine, unpublished data). This site was ca. 2 km east of the 1978 field site (Fig. 5). Although the average temperatures during the first half of the 1978 season are somewhat lower than the previous years, results

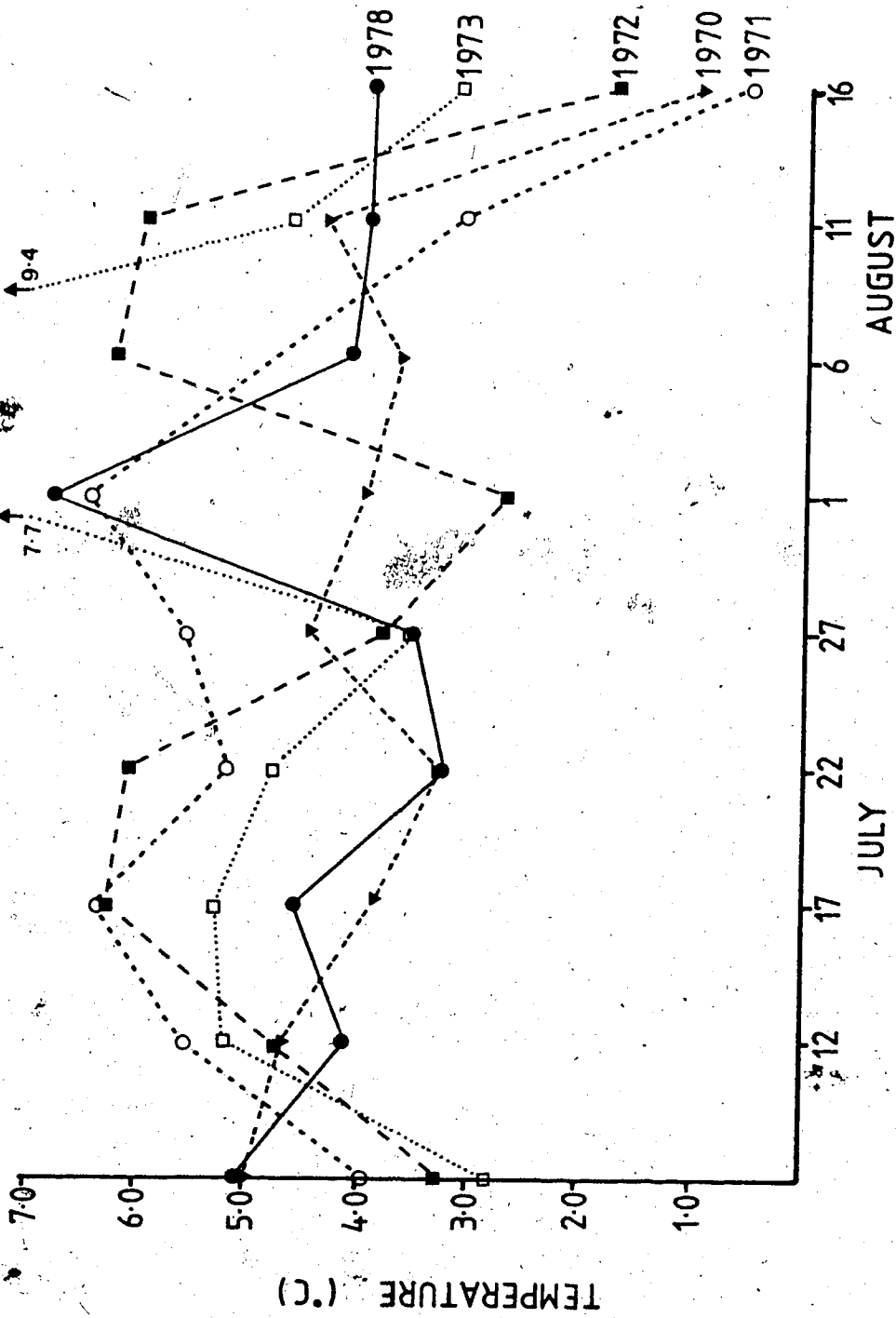

Fig. 17. Variation in air temperature during July and August presented as 5-day means. Data from 1970-1973 were taken at the I.B.P. Intensive Raised Beach site (Courtin and Labine unpub. data). The 1978 field site was ca. 2 km west of the I.B.P. area.

from the latter weeks agree better. Air temperatures remained higher at the end of the 1978 season than during the early 1970's on Truelove. A chinook during 1-3 August 1978 accounts for the sharp increase in average temperature during that time, while Labine (1974) reported clear weather as the reason for the unusually high temperatures in early August 1973.

In general, the 1978 field data fit well among the results from 1970-1973, especially considering the amount of variation from year to year at the I.B.P. site and the distance of ca. 2 km between the sites. Courtin and Labine (1977) reported that the area adjacent to the mouth of Gully River, within which the I.B.P. site lay, was generally warmer than most other places on the Lowland, especially early in the season. This fact, together with the close proximity of Phalarope Lake to the 1978 field site, could account for the slightly lower temperatures at the study area.

During the field season, the lowest recorded temperature was -1°C on 27 July, and on only two other occasions did the temperature drop to 0°C . The maximum air temperature (11°C) occurred on 1 August during the chinook. From Figure 17 it is clear that, excepting the chinook, mean daily temperatures were between 3°C and 5°C during the growing season.

Vapor pressure deficit (VPD) (Fig. 18) exhibited moderately large fluctuations on a weekly and yearly basis.

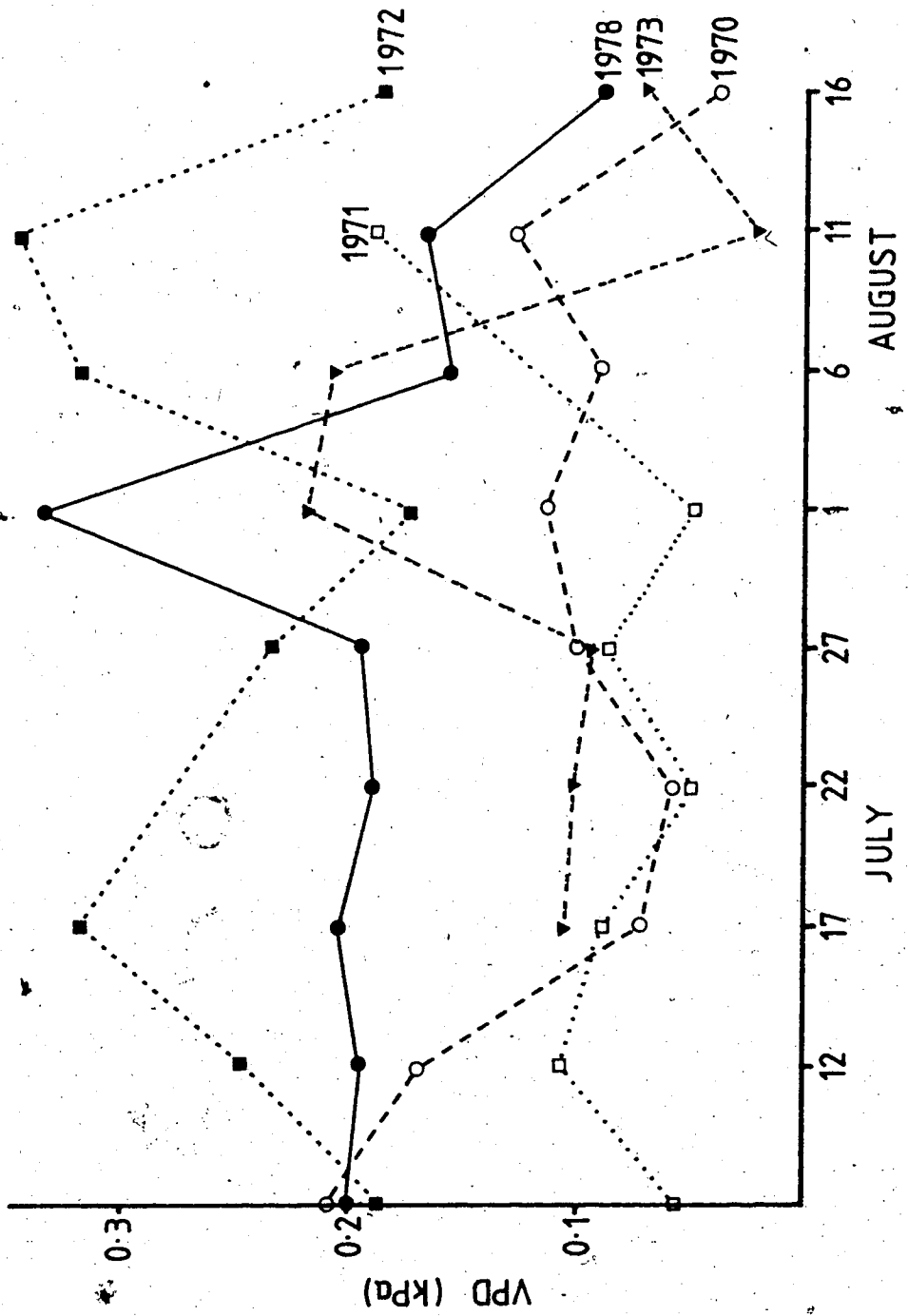

Fig. 18. Variation in vapor pressure deficit (VPD) during July and August presented as 5 day means. Data from 1970-1973 were taken at the I.B.P. Intensive Raised Beach site (Courtin and Labine unpub. data) The 1978 field site was ca. 2 km west of the I.B.P. area.

The 1970-1973 data are from Courtin and Labine (unpublished data). Results suggest that conditions may have been slightly drier at the 1978 site than most years at the I.B.P. site. Courtin and Labine (1977) suggested that the higher VPD's in 1972 may have been a result of cooler conditions and lower precipitation (21.8 mm). This may also explain the 1978 data, with slightly lower weekly mean temperature (Fig. 17) and lower precipitation (21.9 mm) than most I.B.P. years.

In any case, the differences are probably insignificant since the actual VPD's are quite small (.05-0.3 kPa), indicating a relatively moist environment. In summary, the temperature and atmospheric moisture conditions of 1978 were not unlike previous years at Truelove in that no grossly anomalous weather conditions prevailed which could cast doubt on the validity of the experimental results as they might be applied in a general way.

3. Soils: Depth of Thaw

By 10 July the depth of thaw within the study area had exceeded 25 cm (Fig. 19), which is the approximate maximum depth of plant rooting on beach ridge slopes (Svoboda 1977). At midslope, thaw was more rapid and to greater depths than at the slope base. Svoboda (1977) reported a range of 40-70 cm for beach ridge slope active layers throughout the Lowland, and shallower depths (25 cm) for the transition

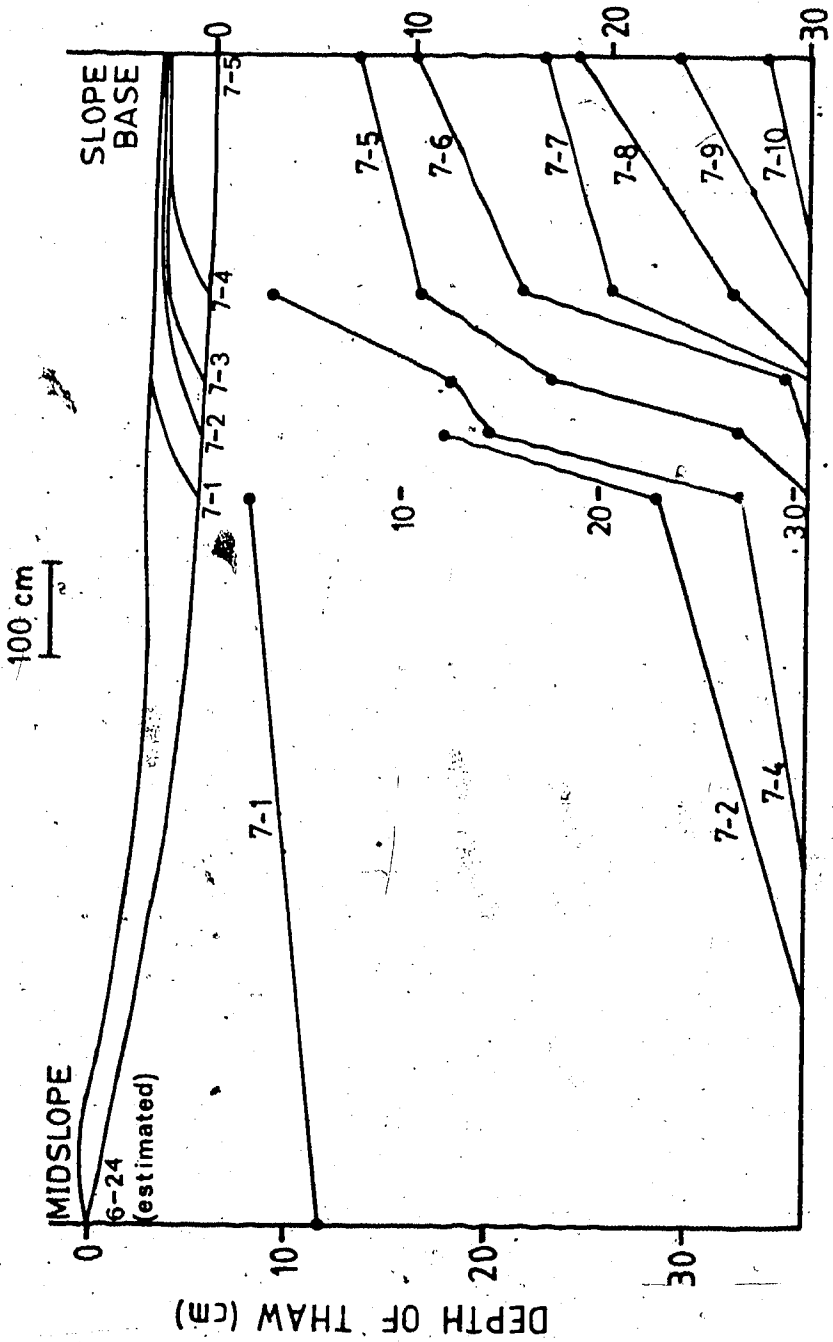

Fig. 19. Development of active layer in relation to the receding snow front. A diagrammatic view of the beach ridge, from midslope to slope base, shows the relative positions of snow fronts on each sampling date. The mean depth of thaw along the slope is also shown for each sampling date (n=3-7). Below 30 cm, depth of thaw is linearly extrapolated to 40 cm, the minimum active layer found for beach ridge slopes by Svoboda (1977).

zones to a meadow. The decrease in active layer with decreasing slope position has been attributed to increasing amounts of soil moisture and increasing amounts of organic material as the sedge meadow at the slope base is approached (Courtin and Labine 1977). The greater amount of organic material provides more thermal insulation, and the higher water content results in more thermal inertia than the drier, more vegetationally depauperate, ridge crest and midslope. The same reasons can account for the different rates of thaw. At the 1978 midslope position more than 20 cm thawed in one day (1-2 July) while at the slope base 5 days were required to thaw the same amount (Fig. 19).

The seven day lag between a thaw depth of 25 cm at midslope, and an equivalent thaw at the slope base is probably insignificant to the results of this study. The aspect of plant growth potentially most affected by the differences would be phenology. From Fig. 19 it is apparent that the various treatment replicates which were spread along the slope became snowfree at different times. It should be noted that snow melt near the slope base was more patchy than indicated in the idealized snow recession. However, there were only differences of 2 to 3 days between the various plants becoming active, which is probably an unimportant difference in terms of cold hardiness. Phenology will be considered further in a later section.

B. Effects of Treatments on Local Plant Environment

1. Radiation

The spectral distribution of sunlight filtered through the different light quality altering treatments is shown in Fig. 6. Implicit in the use of these filters and the resultant shifts in light quality was the assumption that the magnitude of the shifts (i.e. $\zeta=1.00$ to 0.62) would be sufficient to induce a physiological response with respect to cold hardiness and dormancy. Unfortunately, no previous work relating dormancy or cold hardiness to the effects of differences in daytime ζ values has been conducted. Earlier workers who have examined the role of the phytochrome system in the induction of cold hardiness have only considered end of day light effects by short (15-30 min) applications of red ($\zeta=15-17$) or far-red (ζ not given) light (Williams et al. 1972, McKenzie et al. 1974a). The daytime ζ values were not reported, and the end-of-day light treatment was more extreme than that which occurs naturally.

More recently, Morgan and Smith (1978, 1979) examined the effects of different daytime ζ values on development of various plant species. Each light environment differed only in the amount of FR irradiance (PAR constant) given during the 16 hr day, resulting in a range in ζ values from $3.8-0.16$. The phytochrome photoequilibrium ($\emptyset=Pfr/Ptot$) corresponding to each ζ value was obtained from Smith and

Holmes (1977). It was found that the stem extension rate in a number of species was linearly related to θ (Morgan and Smith 1979). This implies that slight changes in θ , resulting from changes in zeta, can result in directly proportional changes in certain morphological traits.

Morgan and Smith have only been concerned with morphological traits in their work, especially in relation to natural shading. The direct extrapolation of their work to cold hardiness and dormancy is not valid. It is almost certainly not the case that, for example, a decrease in zeta results in a linear decrease in plant cold hardiness. More likely a threshold mechanism would be involved, similar to that described by Mohr (1972) for mustard lipoxygenase synthesis and hypocotyl elongation. However, their work shows that there is the potential for the plant to translate small changes in zeta (and therefore in θ) to molecular changes which eventually result in morphological or physiological differences. This provides evidence that the naturally occurring zeta shifts noted earlier ($\Delta zeta = 0.21$) could, theoretically, be of sufficient magnitude to cue the onset of cold acclimation and dormancy. Of course, there is a lower limit of sensitivity to zeta shifts, below which the plant will not respond. This is necessary to avoid the unadaptive triggering of responses by irregular variation in zeta values. Changing weather conditions (e.g. cloud and rain) and overstorey vegetation are two examples of the causes of this type of variation. Therefore, to be useful to

the plant, the shift must be larger than the daily small fluctuations in R:FR ratio which occur randomly.

It is suggested that the zeta shifts created by the treatments were of sufficient magnitude to be effective in cold hardiness and dormancy induction if a phytochrome based cueing was present in the two species. The mean (n=63) July red:far-red ratio at Truelove was 1.12 (range: 0.89-1.54), while the -red filter mean (n=62) was 0.62 (range: 0.48-0.88). The wide range in values resulted from changing sun angle. These values fall within the range where a small change in zeta results in a relatively large change in θ (Smith and Holmes 1977). The phytochrome photoequilibria corresponding to these zeta values, taken from Smith and Holmes (1977), are 0.56 (range: 0.53-0.61) and 0.44 (range: 0.43-0.52), respectively.

Additional support comes from Figs. 13 and 14 from the field site characterization section. Near season's end, the minimum measured zeta values ranged between 0.90-0.95, while the minimum predicted zeta was near 0.83. Both are well above the mean of 0.62 found under the -red treatment. Therefore, the treatment created an environment where red:far-red ratios were well below any natural low value which might function as a threshold for cold hardiness induction at 75° latitude.

The -blue light treatment established a mean July red:blue ratio of 11.57 (range: 7.71-15.89) compared to the corresponding value of 1.70 (range: 1.13-2.33) for

unfiltered sunlight. Figs. 15 and 16 demonstrate the adequacy of the treatment if photocontrol of cold hardiness, via blue light, is operating in *Salix* or *Saxifraga*. Fig. 15 (p. 57) shows that, during August, the maximum red:blue ratios ranged between 2.00 and 2.40, while the predicted ratios ranged up to 5.4 on 6 August. As with the -red treatment, the -blue values were more extreme than the measured and predicted red:blue ratios.

Two effects expected from the short day (SD) treatments were reduced photosynthesis, and early induction of dormancy with increased cold hardiness. However, it has been well established that cold acclimation is an energy requiring process and plants severely depleted in photosynthate cannot harden (Weiser 1970, Alden and Hermann 1971). Since it was possible, due to the short (8 hr) days, that the plants might suffer photosynthetically and respond abnormally, the neutral density (ND) filter treatment was established. As reported in the Methods, the ND filter only transmitted 63% of PAR. From actinograph records, and using a PAR:SW radiation ratio of 0.50 (Szeicz 1974), the amount of PAR incident each day at the field site between 0900-1700 hr CDT was determined and compared to the total PAR received per day, thereby allowing the calculation of the percentage of total PAR available to the SD plants. A mean value of $60.3 \pm 1.1\%$ (range: 48.4-67.3%) was found and compares very well with the 63% transmittance of the ND filter. However, a short period of high intensity light may not be comparable

to a long period of low intensity light, even though the total energy inputs are the same. This is due to light saturation, the point above which additional illumination results in no additional photosynthesis, and to light compensation, the intensity below which respiration exceeds photosynthesis. As a consequence, it is possible that a large amount of the energy considered available to the SD plants was above light saturation, and as well the ND filter may have increased the period for which those plants were operating below light compensation.

Measurements of the light saturation and compensation points of *Salix arctica* and *Saxifraga oppositifolia* are necessary to test the previous considerations. Unfortunately this information is not available for *Saxifraga*. Zalenskij, et al. (1971) reported light saturation of ca. 50,000 lux at 17°C for *Salix arctica* from Western Taimyr. From Tieszen (1973) and Hartgerink (1975) one obtains from 50,000 lux values of 381 cal cm⁻² min⁻¹ and 833 μE m⁻² s⁻¹ as equivalents. From actinograph records it was found that PAR was above the *Salix* light compensation point 33% of the time during which the SD plants were uncovered. However, other factors may have limited photosynthesis apart from light intensity. Tieszen (1975) reported a midday depression in photosynthesis for *Salix pulchra* when the air temperature exceeded ca. 15°C. It was not uncommon for air temperatures under the domes to be above 15°C and 3-6°C warmer than the air surrounding the SD and control plants on clear, calm

days. Hence, the plants with higher air temperatures may have experienced greater VPD's and a greater midday drop in photosynthesis than the open SD and control plants. Therefore, occasions of light saturation in the SD plants may not have been very significant in view of the possible reduction of photosynthesis under the domes.

The second consideration was the possibility of a more frequent drop of light intensity below the compensation point for plants under the treatment domes. Tieszen (1975) reported light compensation for *Salix pulchra* at $14.0 \text{ J m}^{-2}\text{s}^{-1}$ (ca. $22 \text{ } \mu\text{E m}^{-2}\text{s}^{-1}$). Assuming this value to be similar for *Salix arctica*, spot readings of PAR taken during 1978 between 1100-0200 hr show that irradiance below light compensation did not occur beneath the domes until early August, well after the effects of short days became manifest (see Phenology). Consequently, it is unlikely that the dome covered plants suffered significantly from reduced PAR at "night".

Although there is still the uncertainty as to what degree light saturation limited photosynthesis in the SD plants, the fact remains that the total available PAR was essentially the same for all treatments (49-63% transmittance). Consequently, it is suggested that any differences between treatments resulting from changes in light quantity or quality were due to mediation through pigments other than chlorophyll (e.g. phytochrome).

2. Temperature

Figs. 20 and 21 present *Salix* and *Saxifraga* leaf temperatures as degree event accumulations from the thermocouple spot readings. The degree event accumulation was modified from the degree-day concept to allow the use of data obtained at irregular intervals. Although most readings were taken once a day during late morning, occasionally only afternoon temperatures were recorded or temperatures during both the morning and afternoon were read. There were no late night readings. Although the arbitrariness of leaf temperature sampling results in there being little use for the data as an absolute measure of average daily or seasonal leaf temperature, the fact that readings from each treatment were taken within 5-10 min of each other allows the data to be used comparatively. Theoretically, if the treatments had no differential effects on leaf temperature, each curve in Figs. 20 and 21 would roughly coincide, with differences due to variations in leaf angle, local microclimate or the thermocouple-leaf contact (Warren Wilson 1957).

It is apparent that the treatments had little significant effect on *Salix* leaf temperature throughout the season, with the possible exception of the neutral density filter (Fig. 20). There were no significant differences between any mean *Salix* leaf temperatures at the 5% level (Table 2). Similarly, comparisons between *Saxifraga* treatments show no significant differences (Table 2), although temperatures were generally lower under the SD and

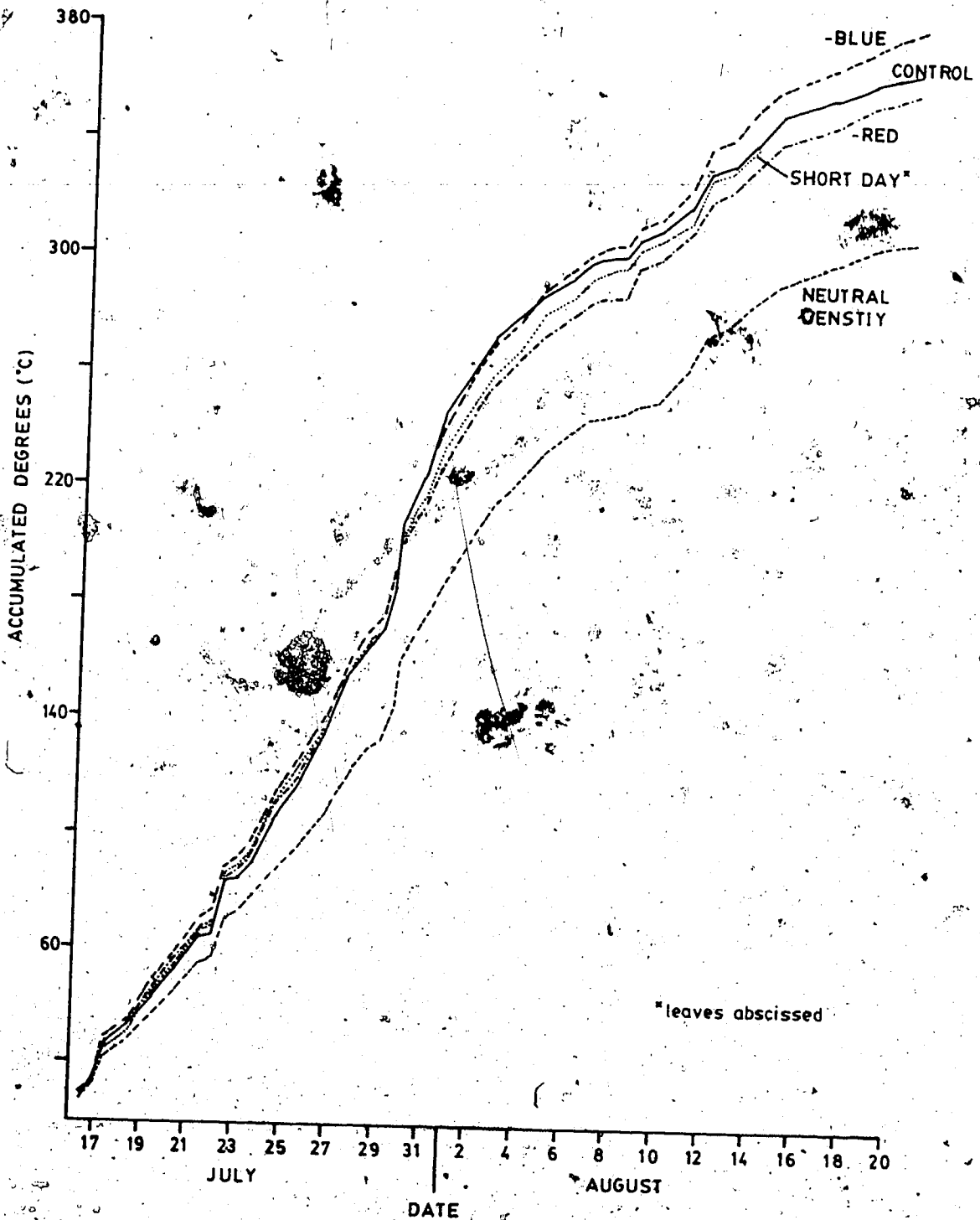

Fig. 20. Accumulated degree events for *Salix arctica* leaf temperatures. The degree event accumulation at a given date is the sum of all thermocouple spot readings of leaf temperature for that treatment up to that date. See text for further discussion.

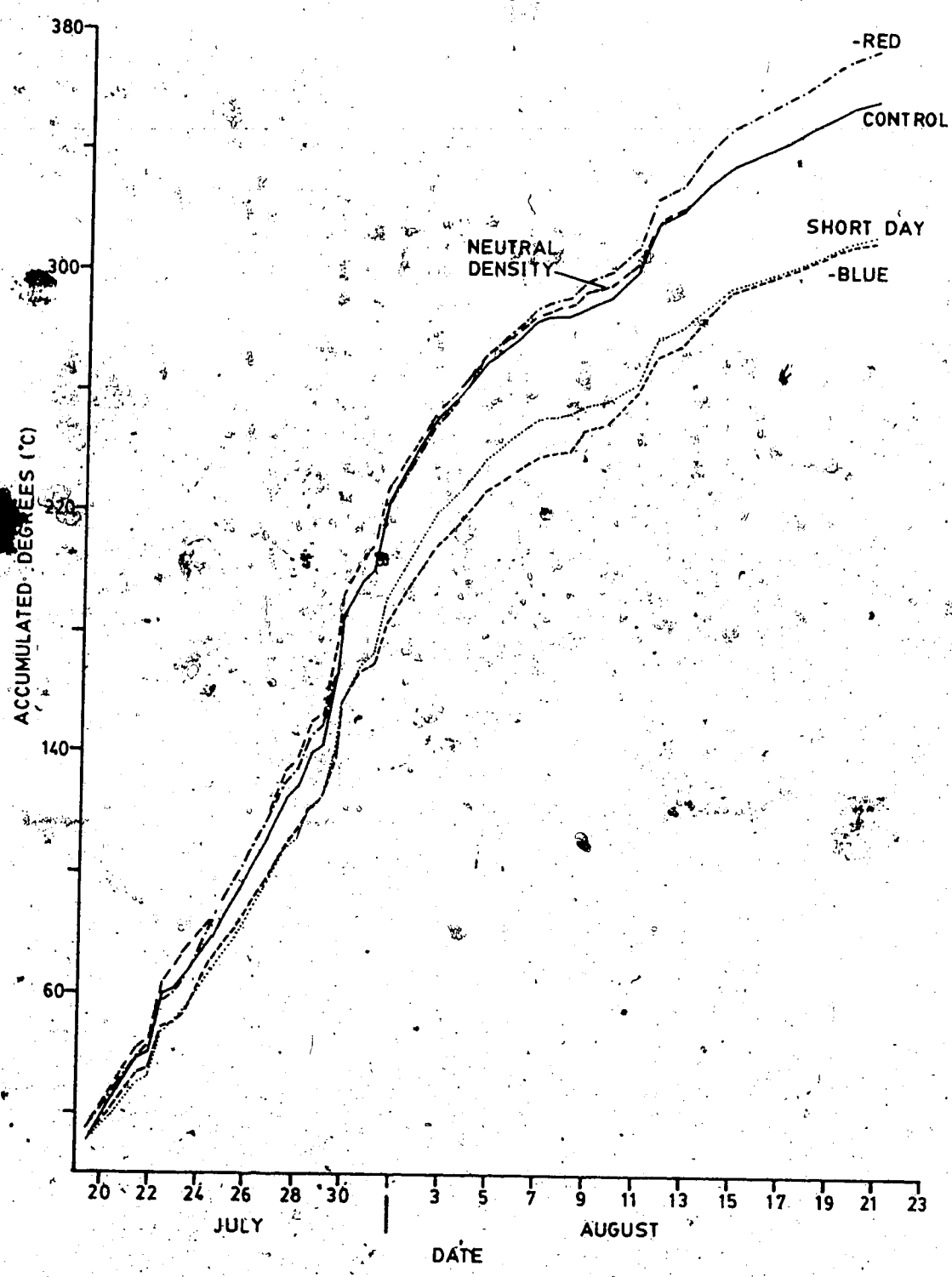

Fig. 21. Accumulated degree events for *Saxifraga oppositifolia* leaf temperatures. See Fig. 20 and text for further explanation.

Table 2. Treatment comparisons of mean leaf, soil surface and subsurface (-5 cm) temperatures (°C) for *Salix arctica* and *Saxifraga oppositifolia* obtained from thermocouple spot readings. Sample size: n=63 (soil), n=40 (*saxifraga* leaves), n=44 (willow leaves except SD (n=3)). Values with a common underline are not significantly different at the 5% level. Analysis of variance was used for comparisons of mean leaf temperatures in both species and for the soil surface temperature data of willow. Due to heteroscedasticity, the Kruskal-Wallis test was employed for the subsurface data and for the *Saxifraga* soil surface results. The STP method of nonparametric multiple comparisons (Sokal and Rohlf 1969) was used to partition the means into significantly different groups. Abbreviations are: CO=control; SD=short day; ND=neutral density; -R=minus red light; -B=minus blue light.

	<i>Salix arctica</i>				<i>Saxifraga oppositifolia</i>				
Leaf	8.9	8.6	8.3	8.1	9.4	8.9	8.9	7.8	7.8
	SD	-B	CO	-R	-R	ND	CO	SD	-B
Soil (0 cm)	8.3	8.2	7.8	7.9	10.6	8.0	7.6	7.5	6.0
	CO	-B	SD	-R	-R	SD	CO	ND	-B
Soil (-5 cm)	6.0	5.1	4.5	4.4	5.2	5.2	5.2	5.1	5.1
	CO	-R	SD	-B	CO	ND	-R	SD	SD

-blue treatments (Fig. 21).

At the soil surface, the ND filter again resulted in slightly lower temperatures for *Salix* (Fig. 22), though not significant at the 5% level (Table 2). For *Saxifraga*, the soil surface temperature under the -red dome was generally well above the other treatments, while the -blue dome gave the lowest temperatures (Fig. 23). Under the -red filter, the soil surface was significantly warmer than all but the SD treatment (Table 2).

The results at -5 cm were very different between the two species (Figs. 24 and 25). Although the mean temperature difference was only 2.0°C between the control and the ND filter, in *Salix*, the control differed significantly from all but the -red treatment (Table 2). The other significant differences between *Salix* treatments are contrasted by the *Saxifraga* results, where all the treatments, except -blue, had essentially the same temperature (Fig. 25, Table 2).

It is difficult to account for the differences between treatments as the result of different radiation environments. One would expect that at least the control and SD results would be very close, since very few readings were taken when the SD plants were covered, and the remaining readings were taken under the same prevailing weather conditions. This holds fairly well, since only at the -5 cm level do the two differ significantly in the case of *Salix* (Table 2). The difference here may be due to the small hummock on which the control plant grew, allowing a warmer

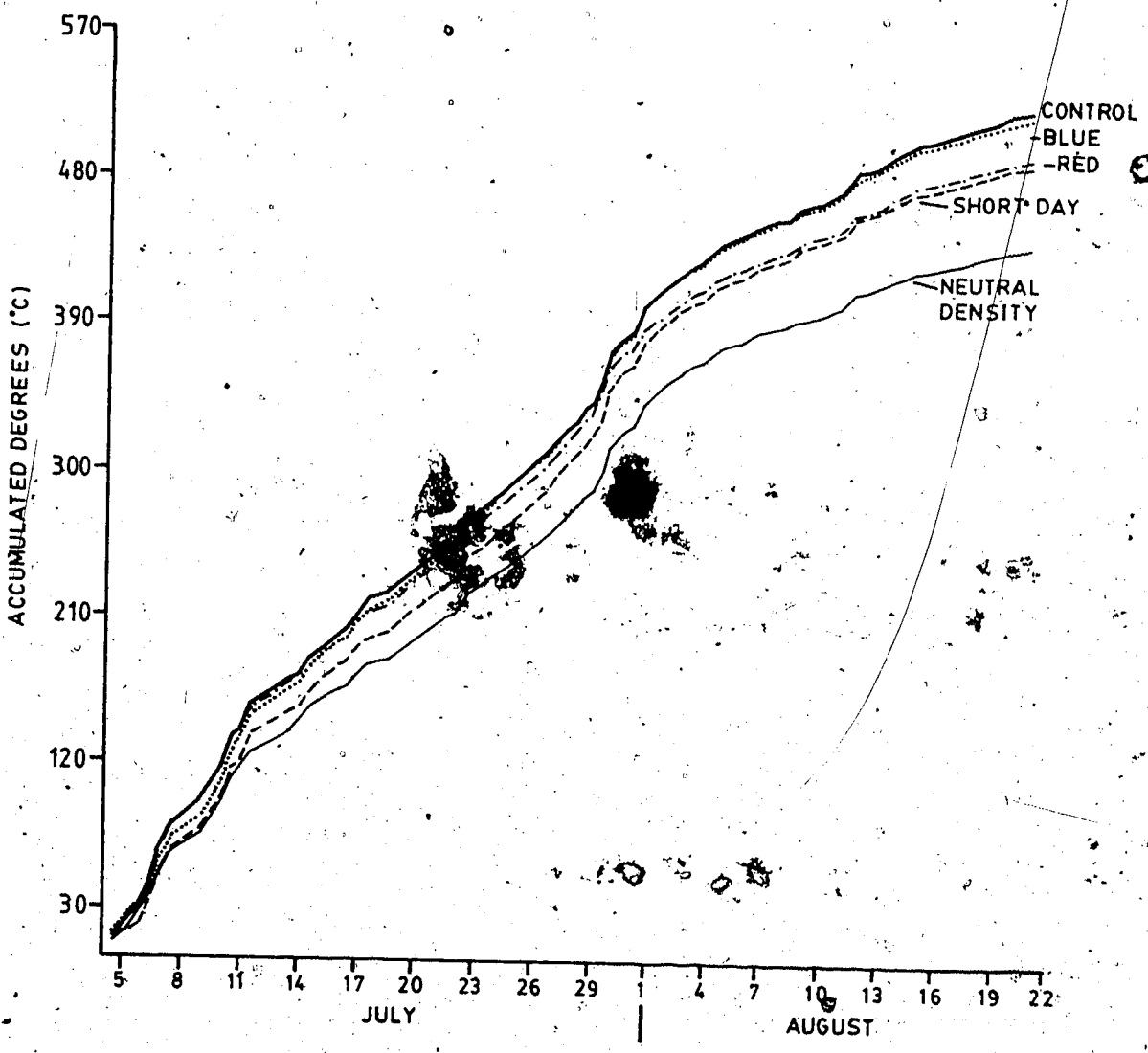

Fig. 22. Accumulated degree events for *Salix arctica* soil surface (0 cm) temperatures. See Fig. 20 and text for further explanation.

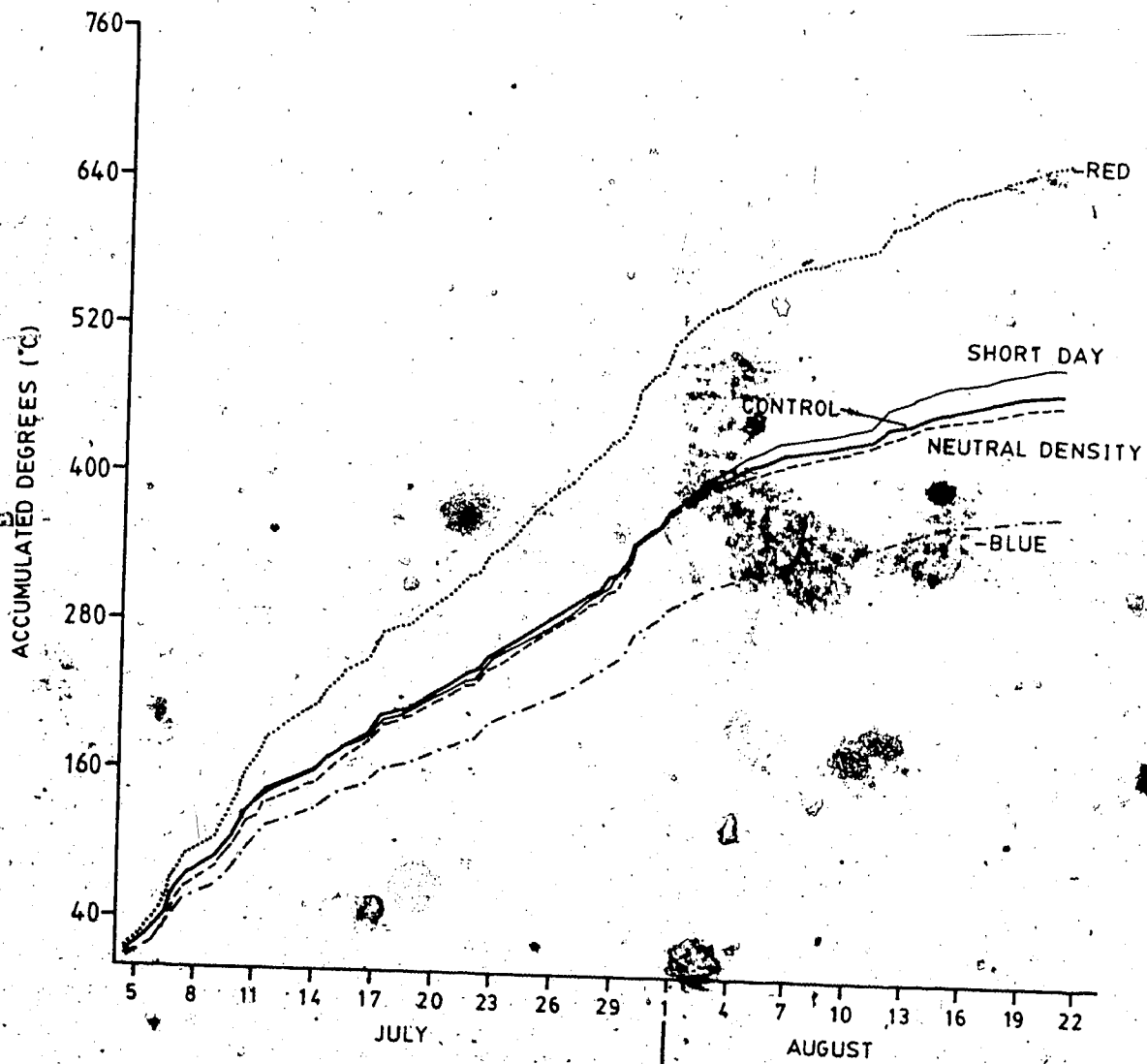

Fig. 23. Accumulated degree events for *Saxifraga oppositifolia* soil surface (0 cm) temperatures. See Fig. 20 and text for further explanation.

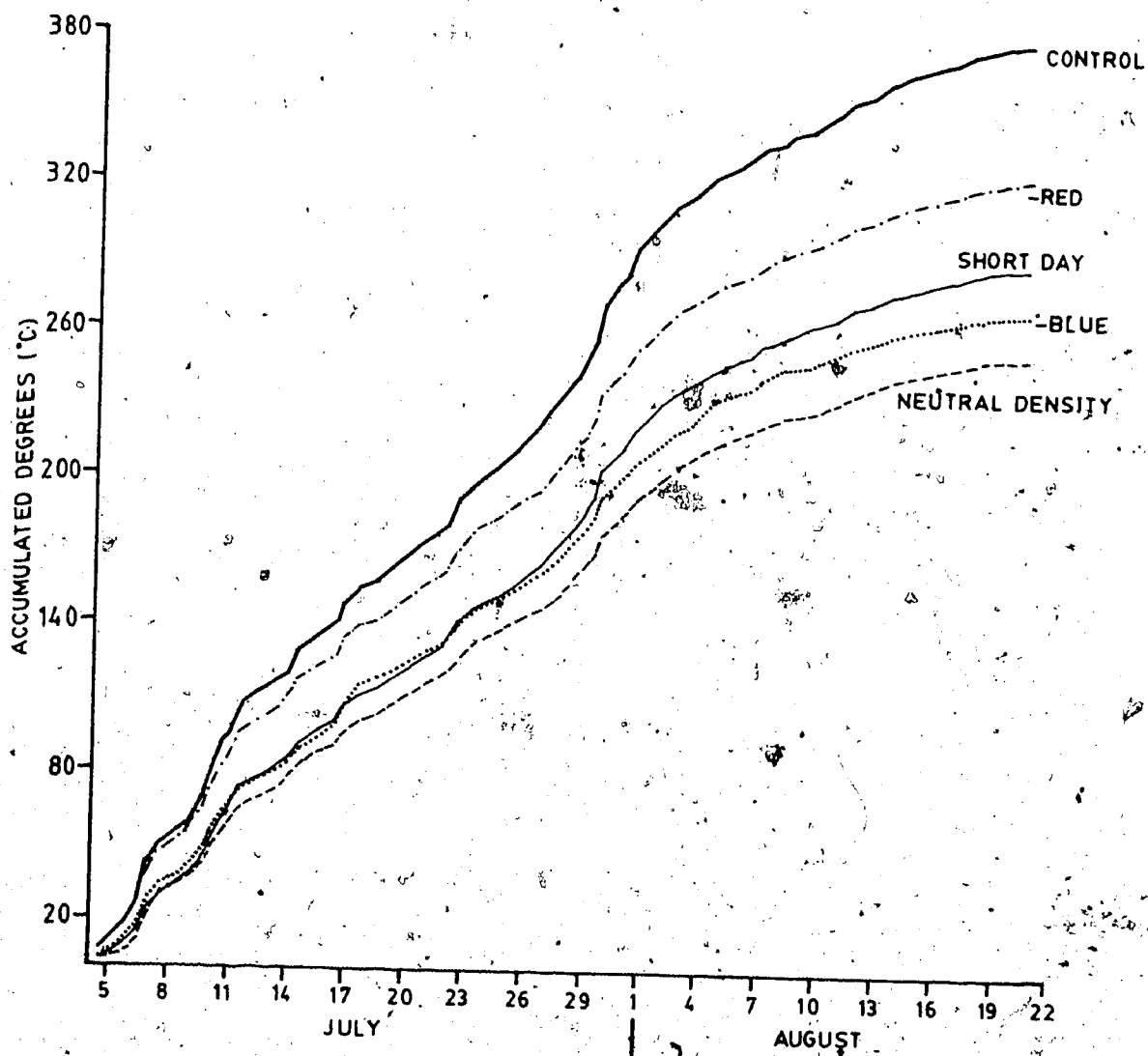

Fig. 24. Accumulated degree events for *Salix arctica* soil (-5 cm) temperatures. See Fig. 20 and text for further explanation.

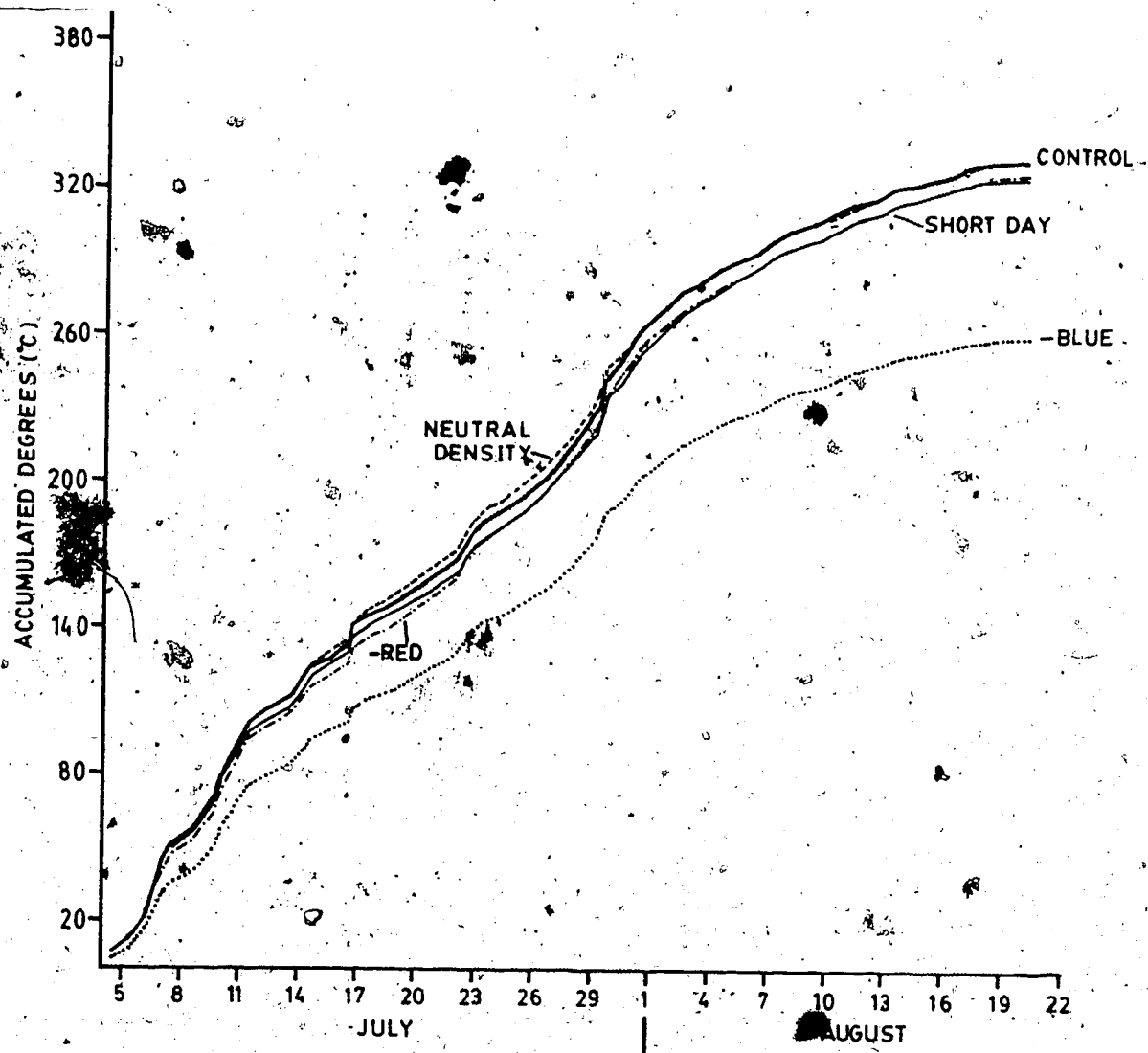

Fig. 25. Accumulated degree events for *Saxifraga oppositifolia* soil (-5 cm) temperatures. See Fig. 20 and text for further explanation.

root environment than plants on flat ground. Also the thermocouples entered the hummock from the south-facing slope, possibly allowing more heat conduction along the wire than normal. Different microtopography may also account for the differences found between other treatments at the soil surface and subsurface.

Morphological differences may be responsible for the different order of warmest to coolest treatments found between species. For example, for *Salix*, the warmest soil surfaces were under the -blue treatment and the control, while for *Saxifraga* it was the -red and the SD conditions (Table 2). Also, the ND filter produced the lowest mean temperatures at all levels for *Salix*, while it was the -blue treatment which resulted in the same for *Saxifraga*. However, it is difficult to understand how, for example, the cushion plant growth form of saxifrage allows a red light deficient radiation environment to warm the soil beneath the plant significantly more than a blue light deficient environment. More difficult to explain is how the -red treatment resulted in a significantly warmer soil surface than the control, which had full insolation (Table 2). Similar problems arise when considering other pairs of differences.

It is suggested that the majority of temperature differences found between treatments was due to different microtopographies and/or microenvironments and, possibly, a result of slight differences in sensor placement. This is not to say that the presence of the domes had no effect on

leaf, soil surface and subsurface temperatures. Rather, that their presence enhanced the effects of the local microenvironment more so in some cases than others. For example, consider a plant occurring in a small depression. It normally has slightly higher temperatures than neighboring flat ground plants, as a result of reduced wind and reradiation from surrounding hummocks. If it were covered with a dome, the result would likely be even higher leaf and soil temperatures regardless of the filter color. In the present case, then, one would not expect any order to the pattern of temperature changes resulting from the domes. With *Saxifraga* all three -red domes would not be expected to consistently have higher soil surface temperatures than the -blue filters, as the results indicate. Unfortunately, only one representative of each treatment was sampled per species and this hypothesis cannot be tested. However, given the difference in order of the heating effects of the same treatments between the two species, and given the known microtopographic heterogeneity of the surface of the field site, it is suggested that consistent differences in temperature did not result from direct effects of the different radiation environments created by the domes.

Apart from the question of consistent statistically significant differences in temperature is the question of biologically significant differences in temperature. It is possible that unusual differences in leaf and/or root temperature could set up an imbalance between photosynthesis

and respiration, resulting in effects like photosynthate depletion and low biomass production, which could complicate the interpretation of treatment effects on cold hardiness and water relations.

Differences in leaf temperature between treatments were probably not great enough to cause significantly different amounts of plant production. Billings et al. (1971), working with *Oxyria digyna* reported only moderate variation in net photosynthesis with temperatures down to 10°C. Tieszen (1978) stated that net assimilation in species from Barrow (including *S. pulchra*) was only slightly inhibited by low temperature, and was much more closely linked to irradiance. He found that *S. pulchra* fixed at ca. 80% of maximum at 3°C (Tieszen 1975). Warren Wilson (1957) observed, however, that photosynthesis is very temperature dependent near 0°C and Pisek et al. (1973) summarized results from numerous alpine studies which indicate that photosynthesis near 0°C is often between 30-40% of maximum. In the present case leaf temperatures were rarely near zero, except at "night" when reduced light resulted in low photosynthesis regardless of temperature. Although the data from Table 2 are not a fair representation of mean daily temperature, they do indicate that leaf temperatures were often between 5-10°C, since most readings were gathered in late morning or early afternoon, when with high light intensities, assimilation was maximal.

Some studies have noted strong correlations between soil temperatures and shoot growth (Bliss 1966, Dennis and

Johnson 1970), although there has been little quantification of this. McCown (1973) reported a 300-500% increase in aboveground annual production when a buried, heated pipeline increased summer soil temperatures in Alaskan tundra 10-15°C above normal. The majority of the increase was due to the stimulation of herbaceous dicots and grasses. Woody dicots responded less markedly, with *Populus balsamifera* in heated soil adding 80 cm of growth compared to 40 cm for plants with unheated roots. These results suggest that the comparatively minor differences in subsurface temperature found between treatments in this study (maximum mean difference of 2°C; Table 2) were probably insignificant in their effects on plant production as far as water relations and cold acclimation are concerned.

It is unlikely that the slight differences in temperature between treatments may have affected the degree of cold hardiness of the plants. Most research supports a two stage process of cold acclimation in woody plants (Weiser 1970; see Introduction) which first involves weeks of long, warm days followed by short photoperiods and warm days with cool nights. Periods of frost bring about the second acclimation stage. In work with temperate plants, the warm temperature regime consists of a 20°C/15°C thermoperiod, while a 15°C/5°C thermoperiod serves for the cool temperature treatment (McKenzie et al. 1974a, Wilkinson 1977, Harrison et al. 1978a). These treatments are well above the temperatures high arctic plants normally

experience (Warren Wilson 1957, Courtin and Labine 1977). Since the temperatures that induce increased levels of cold hardiness in *Salix arctica* and *Saxifraga oppositifolia* are probably very similar to those which are successful in other woody plants ($<10^{\circ}\text{C}$) (see *Salix* cold hardiness results), it is assumed that treatment differences in temperature were insignificant.

3. Wind

Wind speeds at ground level were often significantly lower under the treatment domes than speeds found beside them (Table 3). On two occasions (WN3 and SR3) velocities were higher under the domes, but this probably resulted from a drop in the external wind speed after the under dome readings were made. The nonsignificant differences (Table 3) may be due to the domes having been high enough off the ground to allow close to normal air movement.

In all instances, however, the differences caused by the domes were probably not biologically significant. Of concern here is the effect of wind on leaf temperature, evaporation and gas exchange (Lewis and Callaghan 1976).

Warren Wilson (1959) concluded that the effect of wind on arctic-alpine vegetation was more due to cooling than to evaporative stress. He found that leaf temperatures may be reduced by 7°C due to wind. Other work has shown that wind speeds of ca. $0.9\text{-}1.3\text{ m s}^{-1}$ resulted in heat loss twice that

Table 3. Comparison of wind speeds beside and beneath dome treatments. The sensor was 1-3 cm above ground. Data were collected on various dates and results between treatments are not comparable. W=willow; S=saxifrage; -R=minus red; -B=minus blue; N=neutral density. Pairs were tested by Students t-test or Mann-Whitney U test and significance at the 0.05 (*) or 0.01 (**) level is shown. Sample size is n=10 except n=5 where indicated (1).

=====			
Wind Speed (m s ⁻¹)			
Treatment	Beside Dome	Under Dome	Significance Level

W-R1	0.57	0.46	**
W-R2	2.48	1.56	**
W-R3	0.73	0.49	**
W-B1	0.31	0.12	**
W-B2	1.83	0.56	**
W-B3	0.97	1.06	ns
WN1	1.04	1.11	ns
WN2	0.83	0.89	ns
WN3	1.34	1.80	*
S-B1	1.55	1.28	**
S-B2	0.59	0.38	*1
S-B3	1.96	1.35	**
S-R1	0.72	0.63	ns
S-R2	1.28	1.49	ns
S-R3	1.20	1.57	**
SN1	1.69	1.29	**
SN2	0.81	0.38	**
SN3	1.68	1.27	**

found in a calm period, while at ca. 9 m s^{-1} heat loss was three times that during a calm period (Powell 1961 in Corbet 1972). However, in the previous section it was concluded that temperature differences between treatments were insignificant, and most of the readings were taken with some wind present.

It is difficult to assess whether reduced wind under the domes was favorable to gas exchange and leaf water status, due to the lack of porometry data. At relatively high wind speeds (15 m s^{-1}) *Rhododendron ferrugineum* exhibited a 40-50% reduction in transpiration and a 30-40% reduction in photosynthesis. Transpiration in *Pinus cembra* was relatively unaffected (Caldwell 1970). These differences were attributed to different habitats, with *Rhododendron* occupying more sheltered areas and *Pinus* found on windswept ridges.

Unfortunately, no information is available on the interaction of leaf resistance and wind velocities for the two species under study. However, in light of the relatively low velocities at ground level and the successful growth of the plants at the site, it is unlikely that the domes created a significantly more favorable environment through the slight lowering of average wind speeds.

4. Soil Moisture

In only one instance was the soil moisture under the

domes found to be significantly higher than that outside the domes (Fig. 26). This suggests that, in general, covered plants did not experience abnormally dry soils resulting from protection from precipitation or unusually wet soils from decreased evaporation. Although the soil dried significantly during the first half of July as the moisture from snow melt was depleted, rain replenished the deficit and maintained relatively moist soils throughout the rest of the season. Plants occurring near the crest of the ridge may have experienced drier soils than those near the slope base, where the soil moisture samples were obtained. Whether this resulted in midslope plants being significantly more stressed than those farther down is uncertain.

C. Salix arctica

1. Field Phenology

Only the short day treatment appeared to have any significant effect on the phenology of *Salix arctica* (Fig. 27). Leaf and flower bud break occurred within a period of 3-4 days for all plants, regardless of treatment. The period from flower bud break to flower senescence was very similar in those treatments where the process was completed. The -blue, control, -red, and short day plants averaged 27, 23, 22 and 20 days, respectively (Fig. 27). Under the neutral density regime, the shoots with flowers were cut for cold hardiness tests and therefore the flowers were unable to complete development.

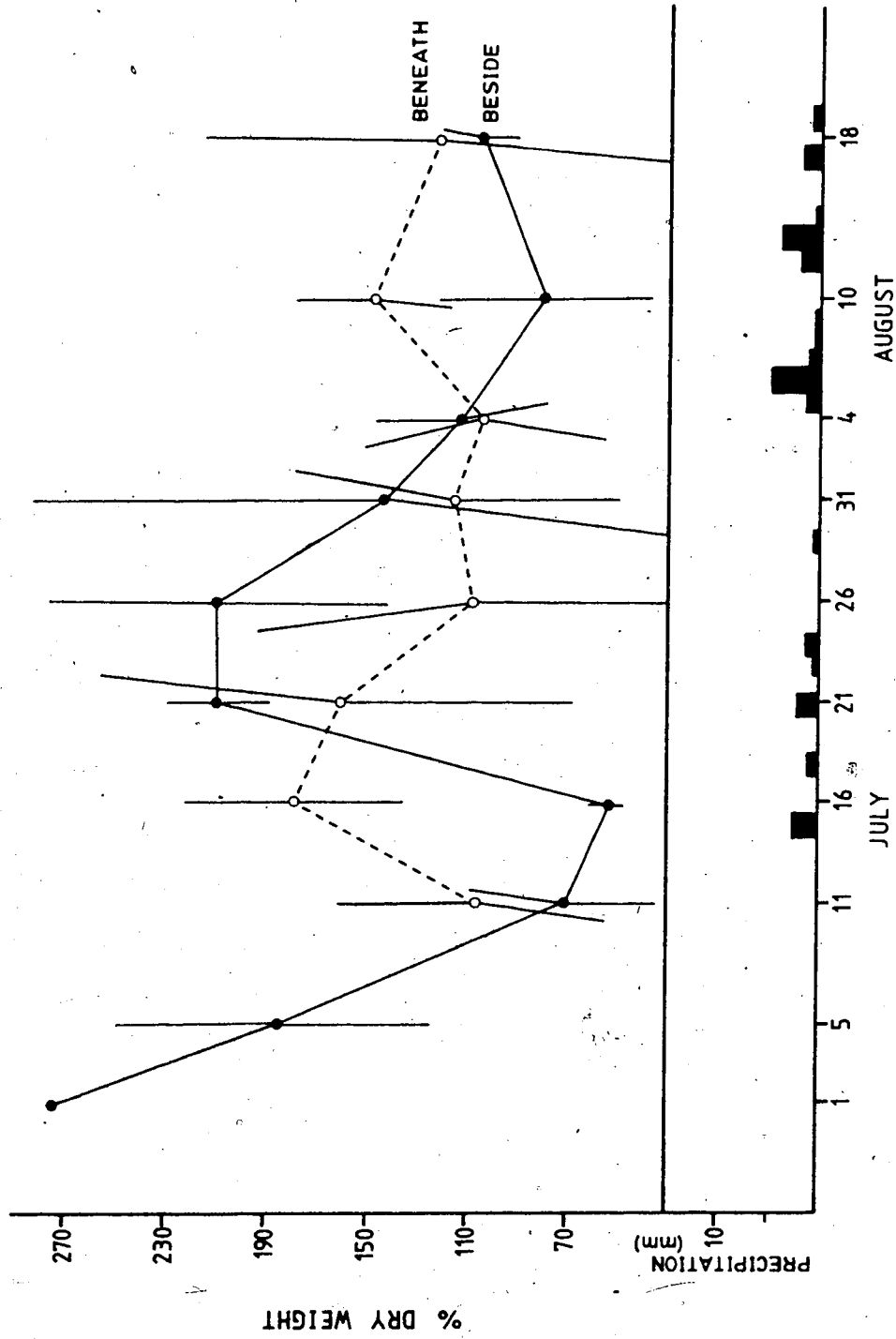

Fig. 26. Comparison between beneath and beside dome variation in 1978 soil moisture. Bars indicate 95% confidence limits. Precipitation (mm) is also shown.

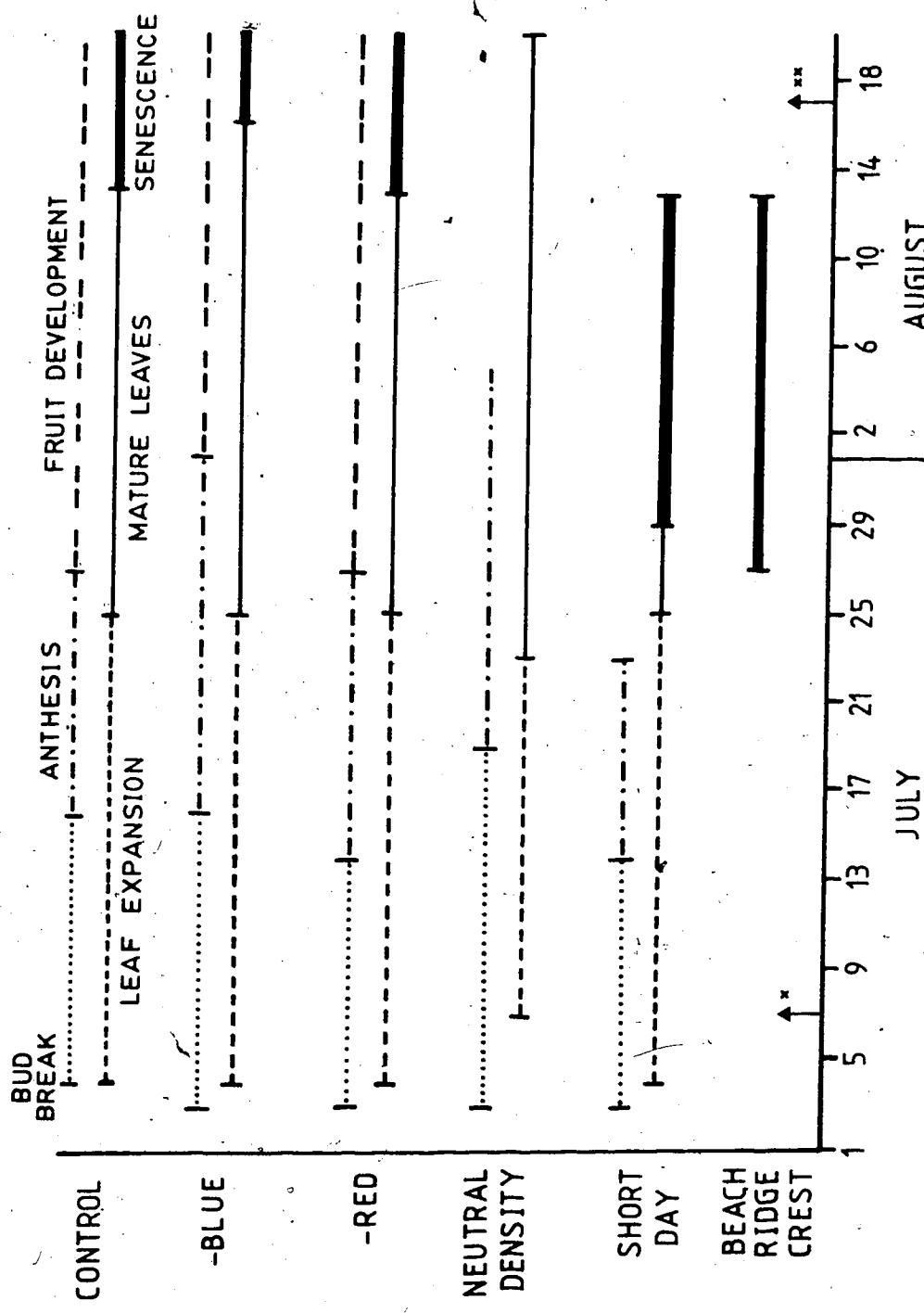

Fig. 27. Effects of experimental treatments on the phenology of *Salix arctica* during 1978. Clipping of the flowering shoots for cold hardiness tests terminated the observations of phenology under the neutral density regime. The beach ridge crest results are explained in the text. (x): initiation of short days; (xx): first sunset.

Although the flowering period under short days may have been shortened slightly relative to the other treatments, the main effect of shortened days was a very early leaf senescence (Fig. 27). The period of leaf expansion appeared to be unaffected by any of the treatments, but leaf senescence began only 4-6 days after completion of expansion for the SD plants, and 5 to 14 days later, all the leaves were yellow. Plants subject to the other treatments ranged from 21 to 30 days after completion of leaf expansion before the first signs of leaf senescence appeared, and the great majority of leaves were still green when observations ended on 20 August. It is clear that the short day treatment greatly accelerated the senescence of *Salix arctica* leaves.

It has been well established that leaf abscission and onset of dormancy in many woody plants is promoted by short days (Wareing 1956, Vaartaja 1959, Vince-Prue 1975). Biebl (1967) induced premature leaf fall in *Salix glauca* at Godhavn (69°N) through artificially shortened days (8 h). In other species of willow it has been shown that short photoperiods can induce cessation of extension growth, apex abortion, leaf senescence, flower bud formation and the formation of resting structures (Alvim 1973 in Alvim et al. 1979, Juntilla 1976, Juntilla 1980a,b). Juntilla (1980a), working in Norway, found that the critical photoperiod for apical growth cessation in *Salix pentandra* seedlings was longer (22 h) for northern ecotypes (69°N) than for southern ecotypes (15-16 h at 59°N). Similarly, flower bud formation

in clones of *S. pentandra* from 49°N occurred under photoperiods of 18 h or less, while 69°N ecotypes formed flower buds under 24 h photoperiods (Juntilla 1980b). It was not noted whether flower buds were formed under SD conditions at Truelove.

While short days induced apical growth cessation and dormancy in seedlings of *S. pentandra* and *Salix caprea*, the same responses occurred in old *S. pentandra* trees growing under natural conditions and continuous days at 69°N. Juntilla (1976) concluded that the natural photoperiod did not seem to regulate apical growth cessation in older individuals of *S. pentandra*. The same conclusion appears reasonable for *Salix arctica* with respect to leaf abscission. Fig. 27 shows that while the first, very brief, sunset did not occur until 17 August, by then leaf senescence had begun for plants under all treatments. Therefore, apical growth had undoubtedly ceased by mid-August in plants subject to 24 h daylength, and the development of dormancy had begun. The different light quality environments had no effect on *Salix arctica* phenology, implying that a high irradiance response (HIR) is not being used by the plants to cue leaf fall. The HIR is characterized by the induction of morphogenic or physiologic changes, mediated through phytochrome, by extended periods of irradiance. On the other hand, the marked effect of short days in accelerating leaf senescence indicates that the low energy phytochrome system may be involved, possibly through

a threshold mechanism. Previous work involving night-breaks with red and/or far-red light during dormancy induction by short days has shown a red/far-red reversibility of effects (Williams et al. 1972, Vince-Prue 1975). Day extension experiments with red and far-red light have shown similar results (McKenzie et al. 1974a, Vince-Prue 1975). Since reversibility of effects is a characteristic of the low energy phytochrome system, the results of these workers indicate that it may be this system that is mediating the short day response.

Even if leaf fall and dormancy can be induced by short days through phytochrome mediation, this mechanism is obviously not the one used by the plant under natural conditions at 75°N. Other species have been found (e.g. *Liquidambar styraciflua* and *Aesculus hippocastanum*) in which dormancy is accelerated by short days, but is still eventually attained under long days (Downs and Borthwick 1956, Vince-Prue 1975). This appears to be the case for *Salix arctica*. The question of photosynthate depletion as a factor in the observed short day response on Truelove was addressed in an earlier section. It is considered that sufficient photosynthetically active light was available, relative to the other treatments, to allow enough photosynthate production for the short day plants to function normally.

A way in which the results of Fig. 27 can be reconciled is presented in Fig. 28. The hypothetical daily changes in θ

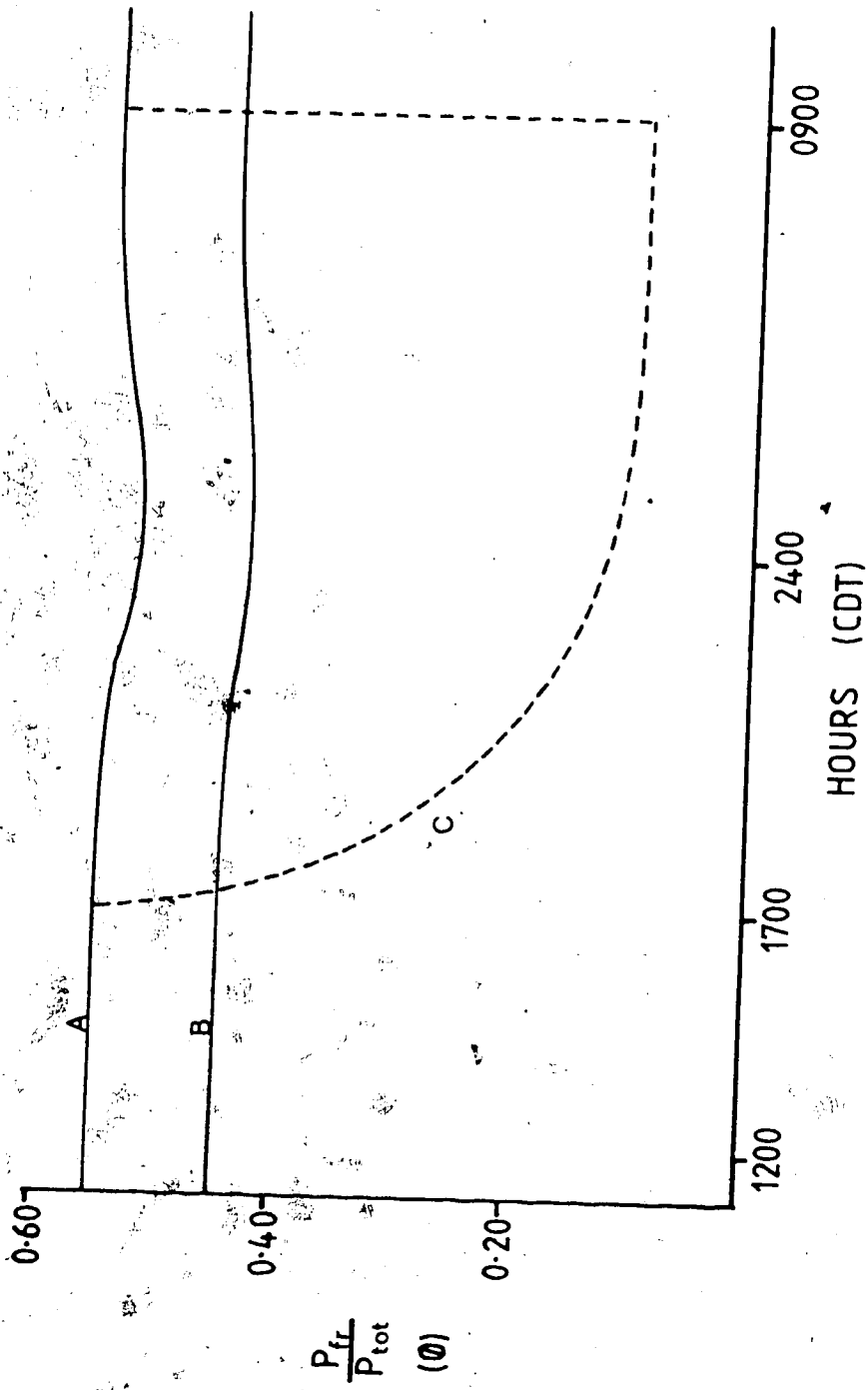

Fig. 28. Hypothetical changes in phytochrome photoequilibria (θ) under (A) continuous illumination on 6 August at 75°N, (B) the same illumination through a -red filter and (C) the short day treatment (8 h light:16 h dark). Modified from Holmes and Wagner (1980).

are shown for natural light and the -red light treatment. These were obtained by applying the relationship between quantum flux ratio and phytochrome photoequilibrium from Smith and Holmes (1977) to the predicted zeta values for 6 August (Fig. 14). Superimposed on these is the probable decrease in \emptyset occurring in short day plants as their time in darkness increases (Holmes and Wagner 1980). It can be seen that a much lower phytochrome photoequilibrium may be obtained during 16 h of darkness than during daylight, since even at low solar elevations and through a -red filter the sun is an effective red light source, relative to total darkness. In this way, a very low threshold value of Pfr may be achieved through long nights, while the phytochrome photoequilibria resulting from daylight may be too large to trigger a response. An alternate possibility is that it is the rate of change in \emptyset which is important (Holmes and Smith 1977a, Holmes and Wagner 1980). The covering of the plant in effect "turns off" the red light (the sun) and results in a rapid drop in the phytochrome photoequilibria (Smith 1975, Holmes and Wagner 1980). Pfr disappearance (through decay and/or reversion) has a half-life ranging from between 30 min and 3 h. Temperature is an important factor in the rate of disappearance (Frankland 1972). It is clear that within a short time after onset of darkness the Pfr level can fall to a low level, implying a rapid rate of change in \emptyset . In addition, a very rapid increase in \emptyset occurs with the uncovering of plants as the red light is "turned on" (Fig.

28). Phytochrome phototransformation kinetics indicate an establishment of phytochrome photoequilibria 10-15 s after a shift in zeta (Smith and Holmes 1977, Holmes 1975 *in* Holmes and Wagner 1980). The rate of change in θ in going from darkness to light would be greater than any naturally occurring rates found during the growing season at 75°N.

It is possible that the response of *Salix arctica* to short days is a "relict" system within the plant; one which was adaptive to its genetic ancestors which grew at lower latitudes, and may still be operational in lower latitude alpine populations of *S. arctica*. It most certainly occurs at lower latitudes in other *Salix* species (Alvim 1973 *in* Alvim et al. 1979, Juntilla 1976, Juntilla 1980a,b). At high latitudes, the absence of sufficiently short days (ie. correct Pfr threshold) before the occurrence of lethal temperatures would make the system unadaptive and likely fatal to plants which relied on it. It is apparent from the failure of the light quality treatments to induce early senescence and dormancy that an upward shift of the Pfr threshold has not occurred in high arctic populations. There is evidence that some kind of internal regulation, which may involve an endogenous rhythm (Bünning 1973), is operative. This is seen in the phenology of *Salix* plants growing on the beach ridge crest, upslope from the study site.

A small group of 3 or 4 *Salix arctica* plants on the ridge crest were watered daily from 9 July to the end of their growing season. This was done to insure adequate

moisture, as some workers have reported drought as a factor responsible for early growth cessation (Zahner et al. 1964, Perry 1971). Despite daily watering, leaf senescence in these plants began in late July at approximately the same time as the SD plants (Fig. 27). Some of the other, unwatered, individuals of *Salix* on the beach ridge began leaf yellowing at the same time, suggesting either that moisture was not a controlling factor for these plants, or that the degree of watering was insufficient to prevent water stress induced dormancy. By mid-August, the watered plants in the beach crest had completed leaf senescence, while the lower leaves on the control plants near the slope base were just beginning to yellow; a difference of ca. 17 d. Both sets of plants experienced very similar radiation and temperature environments, and in the absence of differences in water stress, the time of snow release (and emergence from dormancy) remains as the major difference between the two groups.

The mean time period between bud break and the first signs of leaf senescence in the control plants was 38 d. In the -blue, -red, and short day plants it was 40, 35 and 25 d, respectively. Only one of the three neutral density plants had begun to senesce when seasonal observations were ended 44 d after bud burst. If all but the short day results are combined, the mean period between bud break and senescence is 40 d. Using this value one can extrapolate back to the approximate point at which the ridge crest

plants began seasonal growth. This 40 d period may be shorter or longer some years depending on how temperature affects the hormonal interactions which are presumably involved in the endogenous rhythm.

In the present case, 40 d prior to 27 July is 17 June. Although 1978 phenological observations did not begin until 2 July, more complete records from Truelove are available from previous years. Svoboda (1977) reported snow melt on the Base Camp raised beach crest to have occurred on 18 June and 13 June during 1970 and 1971, respectively. *Salix* leaf bud break occurs 5-7 d (this study) or 7-10 d (Svoboda 1974) after snow release. This wide range of time leaves 17 June as a very plausible date for leaf bud break in 1978 if the early portion of the season was similar to 1970 or 1971. The patchiness of snow melt could account for the variability between ridge crest plants in the emergence from dormancy, which would later be manifest as the differences in the beginning of leaf senescence mentioned earlier.

Other workers have reported evidence that some arctic and subarctic species, including willow, exhibit a "biologically fixed" (Muc 1977) growing season which suggests an internal regulation of leaf senescence and dormancy onset. Schulz (1949 *in* Wareing 1956) found subarctic species of *Salix*, *Betula*, *Ribes* and *Vaccinium* formed winter resting buds under continuous illumination while species of those genera from lower latitudes could not. Individuals of *Salix arctica* transplanted from NE

Greenland (70-78°N) to Denmark (ca. 56°N) and cultured there for several years, initiated leaf senescence during June and began a new leafing after a short rest period (Sørensen 1941). Muc (1977) and Svoboda (1977), working on Truelove, alluded to evidence for a relatively fixed actual growing season (bud break to 50% leaf coloration), which was species specific and independent of the potential growing season (snow melt to mean temperature below 0°C). Hartgerink found evidence for the same with *Dryas integrifolia* (Mayo, personal communication). The phenological data presented earlier tend to support the concept of a biologically fixed growing period for high latitude populations of *Salix arctica*. The mechanism of regulation is, presumably, through seasonal changes in the internal concentrations of hormones relative to each other.

2. Field Cold Hardiness

a. Leaves.

There appears to have been little or no effect of the treatments on the cold hardiness of *Salix arctica* leaves (Fig. 29). Between mid-July and mid-August hardiness in the leaves of the control plants increased from a low of -8.4°C to a maximum of -13.8°C. Trends among the treatments are not as clear. Throughout the season the plants subjected to a -red environment ranged only slightly in hardiness (2.5°C), but in an evenly fluctuating pattern. Cold tolerance began

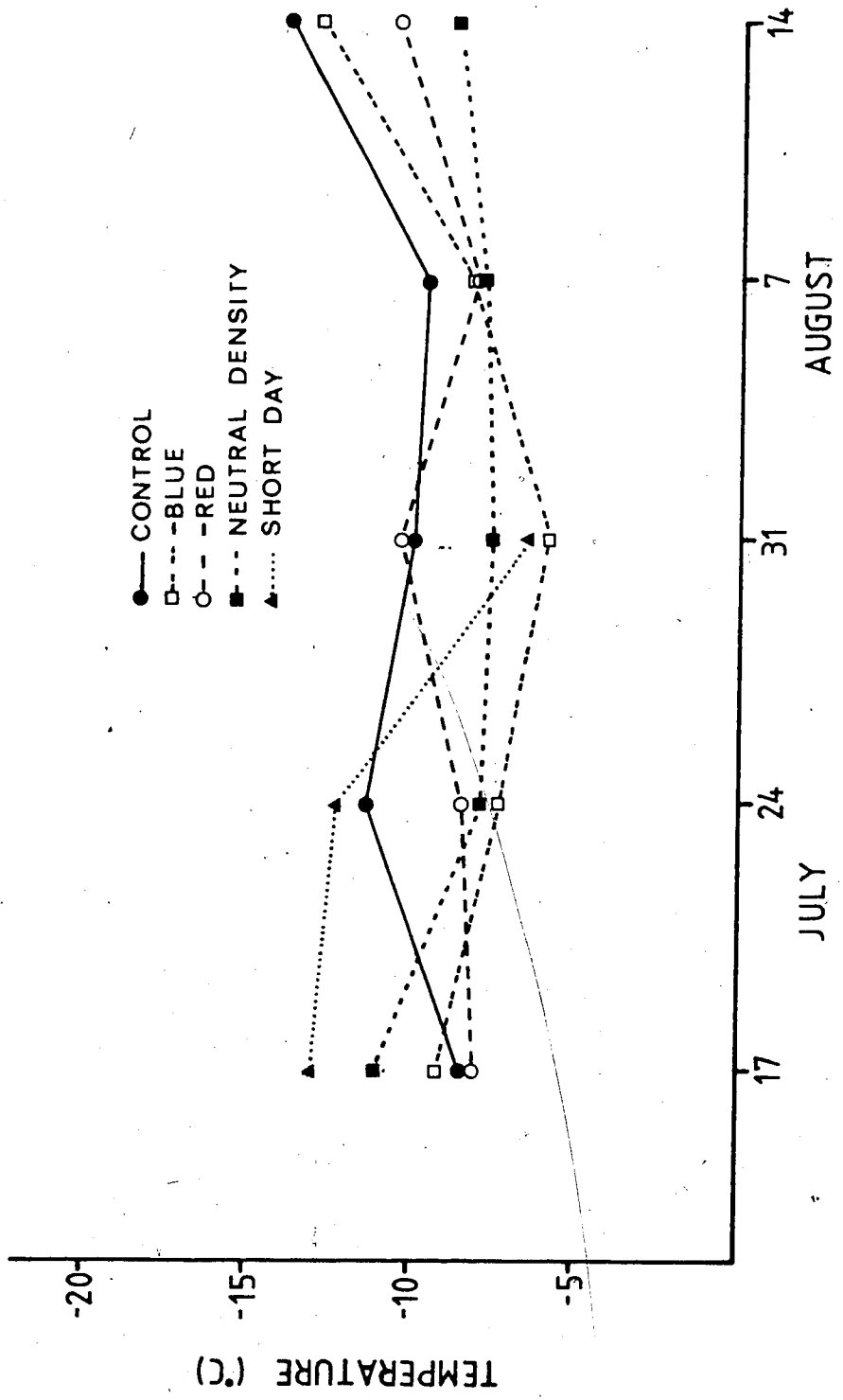

Fig. 29. Effects of the field treatments on the cold hardiness of *Salix arctica* leaf tissue. Abscission of leaves from short day plants ended further testing of those plants. Samples for each treatment were taken from three plants.

at -8.0°C , with an increase to -10.3°C at the end of July, and a decrease again to -8.0°C before the final increase to -10.5°C in mid-August. Plants under the neutral density filter dropped in hardiness from -11.0°C in mid-July to -7.8°C two weeks later, and remained at that level throughout the rest of the sampling season (Fig. 29).

Both the -red and neutral density treatments resulted in a seasonal range in cold tolerance less than that of the control plants (2.5°C and 3.5°C , respectively), and with no discernible pattern. This suggests that the observed variation resulted from limited resolution due to a certain amount of "noise" in the TTC test for this particular tissue. Steponkus and Lanphear (1967), in their original refinement of the TTC method, stated that with *Hedera helix* a standard error of the mean (SEM) of 1.5°C was routinely achieved. Based on this, even with a very large sample size a 95% confidence interval around any point was ca. ± 2 SEM or $\pm 3.0^{\circ}\text{C}$. To apply this confidence interval to the present case is not statistically sound, but in the absence of the means to derive a confidence interval from the field data, it can serve at least as a rough measure of the resolution of the TTC test and as a guideline to aid in the decision of significant differences. Therefore, no resolution of the lethal temperature better than $\pm 3^{\circ}\text{C}$ can be expected with willow leaf tissue. The same also holds for stem tissue.

If this criterion is applied to the remaining two treatments (-blue and short days), there is some evidence

for a real change in leaf cold hardiness. From mid-July to the beginning of August (2 weeks), the leaf cold hardiness of the short day plants decreased from -12.9°C to -6.4°C . Plants subject to the -blue treatment decreased in hardiness from -9.1°C in mid-July to -5.8°C two weeks later, and then increased to -12.9°C by the last sampling (Fig. 29). In both cases a net change of $>6^{\circ}\text{C}$ occurred over a period of two weeks.

The initially high cold tolerance of the SD treated leaves and the subsequent sharp drop may have resulted from a conflict between processes involved in leaf growth and expansion, and the process of leaf senescence. Actively expanding leaves import assimilates (Salisbury and Ross 1978) and this results, for a time, in higher cell solute concentrations than the mature leaf. Also, during senescence, the solute content of the leaves increases as the breakdown of more complex compounds occurs and their translocation to perennating structures (e.g. roots, stems, buds) takes place (Oland 1963, Zimmerman 1964, Pate 1975, Beevers 1976). As well, many studies have shown the presence of osmotically active cell solutes to result in a depression of the freezing point to about -5°C to -7°C , and in exceptional cases to -10°C to -12°C (Sakai 1962 *in* Levitt 1972, Levitt 1972, Larcher et al. 1973). If solute translocation was occurring in the short day plants from mid- to late July, an increase in leaf freezing tolerance may have resulted from the temporarily higher solute

concentrations (e.g. amino acids) in the leaf. It is evident that senescence was induced abnormally early in the SD plants (Fig. 27) and it is possible that opposing processes were occurring in the plants. On the one hand, the normal sequence of leaf development, beginning with bud break, involves influx of solutes. At the same time, the shortened photoperiod induced the onset of senescence which involves the efflux of solutes. Whether the efflux and influx of solutes were occurring concomitantly is unknown, but either alone or both together may explain the increased freezing tolerance 1-2 weeks before the first visible signs of yellowing. The apparent decline in hardiness at the end of July may have resulted from either a loss in ability of the leaf to withstand otherwise tolerable low temperatures, or the failure of the TTC test to remain an accurate indicator of hardiness. Both features could be a result of the changes in metabolism known to occur in senescing leaves. This includes, at least in the later stages of senescence, a decline in the respiration rate (Beevers 1976). Because TTC can act as an electron acceptor for the various dehydrogenases in the tricarboxylic acid cycle, a decrease in respiration would result in a decreased reduction of the dye.

With respect to the -blue treatment it is difficult to account for a drop in frost tolerance as a result of an environment deficient in blue light (Fig. 29). It is probable that the observed changes (from -9.1° to -5.8°C)

are simply variations around a relatively stable value of ca. -7.0° to -8.0°C . However, the apparent rise in tolerance to -12.9°C may be a result of the beginning of natural leaf senescence. The same is probably true of the similar increases seen in the control (-13.8°C) and red treated (-10.5°C) plants. These increases in hardiness coincided with the visible onset of senescence, unlike the case with the SD plants where a decline in hardiness occurred with visible leaf yellowing. The conflicting processes which may have been occurring in the SD plants may offer an explanation for the differences between these two sets of plants.

As mentioned above, an increase in the cell solute concentrations associated with senescence may confer an additional amount of hardiness in the form of freezing avoidance through freezing point depression. While the accumulation of amino acids during leaf senescence is well established (Beevers 1976), total amino acid content has not been consistently related to increased frost tolerance (Levitt 1972). But the fact that it has been reported by some investigators (Wilding et al. 1960, Paulsen 1968) and that, in particular, the amino acid proline has been found by some to accumulate in hardening tissue (Parker 1958, Durzan 1968, Levitt 1972), at least allows for the possibility that the depressed killing temperature may have been related to the amino acid content in the senescing willow leaves. Russel (1940) studied seasonal changes in the

carbohydrate content of *Oxyria digyna* on Jan Mayen Island. He found a considerable increase in the sugar content in the aboveground tissue and suggested a relationship to cold hardiness. A test on 31 July of the remaining green leaves of the ridge crest plants, which were two weeks ahead of those at the slope base, resulted in a LT 50 of -14.0°C , and supports the above contentions.

Plants under the neutral density regime displayed no evidence of an increase in hardiness in mid-August like that found in the other plants (Fig. 29). From Fig. 27 it is apparent that the process of leaf senescence in these plants was later than in the other treatments. Therefore, the accumulation and export of amino acids may have not yet begun to any significant degree by the time of the last cold hardiness sampling (14 August). Hence, an increase in frost tolerance would not be evident, and this was found to be the case.

With the exception of the short-day treatment, the mean seasonal LT 50 for each set of plants was determined. The results from the final sampling date were excluded in the case of the control, -blue and -red treatments because the effects of increased cell solutes may have been involved. Based on these data, the mean killing temperature ($\pm\text{SEM}$) for the leaves of the control, -red, -blue and neutral density plants was $-9.8\pm.6^{\circ}$, $-8.7\pm.5^{\circ}$, $-7.8\pm.7^{\circ}$ and $-8.6\pm.8^{\circ}\text{C}$; respectively (from Fig. 29; $n=4$). The largest mean difference between any two groups is 2°C , and given the

resolving power of the TTC test it can be concluded that these differences are not significant. If all the groups (excepting short days) are pooled, the mean value for the cold hardiness of arctic willow leaves is $-8.6 \pm .4^{\circ}\text{C}$. The effect of short days appears to have been indirect, through acceleration of senescence.

It is not surprising to find that the treatments had no effects on the cold hardiness of willow leaves. There is no advantage to deciduous leaves becoming cold hardy in response to changes in light quality. Instead they generally act as receptors of a cue and source of translocatable factors which move to the stem and prepare perennating structures for conditions in the weeks ahead which are lethal to tissue in an active state of growth. The leaves are shed well before severely cold conditions set in, as part of the preparation. Although there may be periods of mild frost at any time during the growing season in the High Arctic, the unpredictability of frost precludes any environmental cue other than temperature from being useful as a warning. This response to temperature would need to be quite rapid to avoid damage. However, air temperatures rarely drop below -5°C during the growing season at these latitudes, and the degree of summer hardiness found for *Salix arctica* is probably more than adequate.

The leaf cold hardiness was not determined during the controlled environment portion of the study, but the results of determining the correlation between TTC reduction and

leaf disk survival (Fig. 3) afforded a direct check on the field observations. Plants used in deriving the correlation were grown under a 16 h/12°C 8 h/4°C regime with continuous light. Under these conditions a cold hardiness of -7°C was determined directly from leaf disk survivorship results. This value is slightly lower than the field results (-8.6°C) but within the range of resolution of the TTC test.

The results of this study compare favorably with those of other workers if the the different testing conditions are taken into account. Biebl (1967) reported the cold resistance of *Betula nana* and *Salix glauca* leaves at Godhavn, Greenland (latitude 69°N) to be -4°C for both species. After 17 days of short day (8 h) treatment the cold hardiness of *B. nana* increased to -6°C while *Salix* remained unchanged. Premature leaf coloring (red for *Betula*; yellow for *Salix*) was noted in both. Biebl (1968) also studied the July frost tolerance of 20 arctic species from Godhavn, and found the leaves of most plants to be killed or greatly damaged at temperatures between -5° and -10°C (see Introduction). *Salix pauciflora*, a prostrate willow native to the alpine of northern Japan, was found to survive leaf temperatures from -5° to -9°C, with slight to moderate browning (Sakai and Otsuka 1970).

While the results of these studies were similar to this work, some of the discrepancies may be due to differences in the method of injury assesment and to differences in definition. Biebl (1967) held the tissue at each test

temperature for 24 h before thawing at room temperature and observing the degree of injury after 3-5 days. He considered the "resistance limit" to have occurred if the amount of injury exceeded 5-10%. Similarly, survival of *Salix pauciflora* was based on a visual browning test; normal, slight, medium or killed. Freezing resistance was reported as the lowest temperature at which no injury occurred (Sakai and Otsuka 1970). In contrast, *Salix arctica* shoots from Truelove were stressed at a rate of decreasing temperature of $-4^{\circ}\text{C h}^{-1}$ and assessment of survival was ultimately based on the 50% survival of leaf disks floated on Hoagland's solution. Thus, the two previous workers were more conservative in their estimation of survival.

Visual assessment of survivorship is fairly subjective and the post-treatment conditions were probably not as favorable in the two previously mentioned studies as in this one. It seems likely that leaf disks floating on a nutrient rich medium with high (30°C) temperature and constant light will continue to live longer than leaves still attached to the plant and maintained at room temperature (Biebl 1967) or in a greenhouse (Sakai and Otsuka 1970). If this is so, then the leaf disk method would tend to overestimate leaf cold hardiness relative to the temperature that field plants could survive, given that post-treatment conditions in the field are less than ideal. The use of intact plants by Biebl (1967) and Sakai and Otsuka (1970) may have approximated natural conditions more closely, and therefore may be closer

to estimating actual field survival temperatures, despite the subjectivity of the visual browning test.

On the other hand, both studies used more rigorous definitions for "freezing resistance". If the temperature at which 50% of the tissue is dead is taken as defining the cold hardiness or freezing resistance, rather than 5-10% prominent injury or no injury, then the survival temperatures of the leaves of the willows from Greenland and Japan would very likely drop to near the -7° to -9°C found in this study. An additional point is that Sakai, using the same "injury free" definition of resistance as earlier, found the freezing resistance of *Salix rotundifolia* from Barrow, Alaska (71°N) to be "about -5°C " in late July (Sakai and Otsuka 1970). He did not state whether it was leaf or stem tissue. If it was leaf tissue, the above "correction" for definition would put the results into the same temperature range as arctic willow.

b. Stems.

Although the majority of the field work dealt with the cold hardiness of leaves, some stem tissue was tested near the end of the season. Plants from the beach ridge crest were compared with plants growing in the beach ridge-meadow transition zone, with the goal of determining whether differences in phenology correlated with different degrees of stem cold hardiness. Plants from the ridge crest had significant signs of leaf senescence (yellowing) at the time

of the first cold hardiness test (31 July) and were entirely yellow by the last test (15 August). The transition zone plants had very little or no yellowing by 15 August. The results indicate that an increase in hardiness accompanies the onset of leaf senescence and the development of dormancy (Fig. 30).

Willow from the ridge crest maintained a fairly constant and high level of stem cold hardiness, with values that ranged from between -26° to -28°C . Plants in the transition zone appeared to be hardy to -15° or -18°C , except for one anomalously high value of $<-25^{\circ}\text{C}$ in early August (Fig. 30). It is difficult to account for this latter point since there were no significant changes in the environment at this time which might temporarily increase hardiness. There was, however, a fair amount of variation in absorbance values at the 0°C (control) temperature in this particular test, and it is likely that the mean value was not accurately representing the actual activity of the tissue at that temperature. The -5° and -10°C stressed tissue showed much higher activity relative to the control (122% and 108%, respectively). Therefore, due to uncertainty, the 9 August value was ignored and the hardiness level during early to mid-August was taken to be between -15° and -18°C for transition zone willow.

Since transition zone plants lag behind the ridge crest willow, phenologically, by approximately three weeks, the stage in the seasonal cycle of activity appears to affect

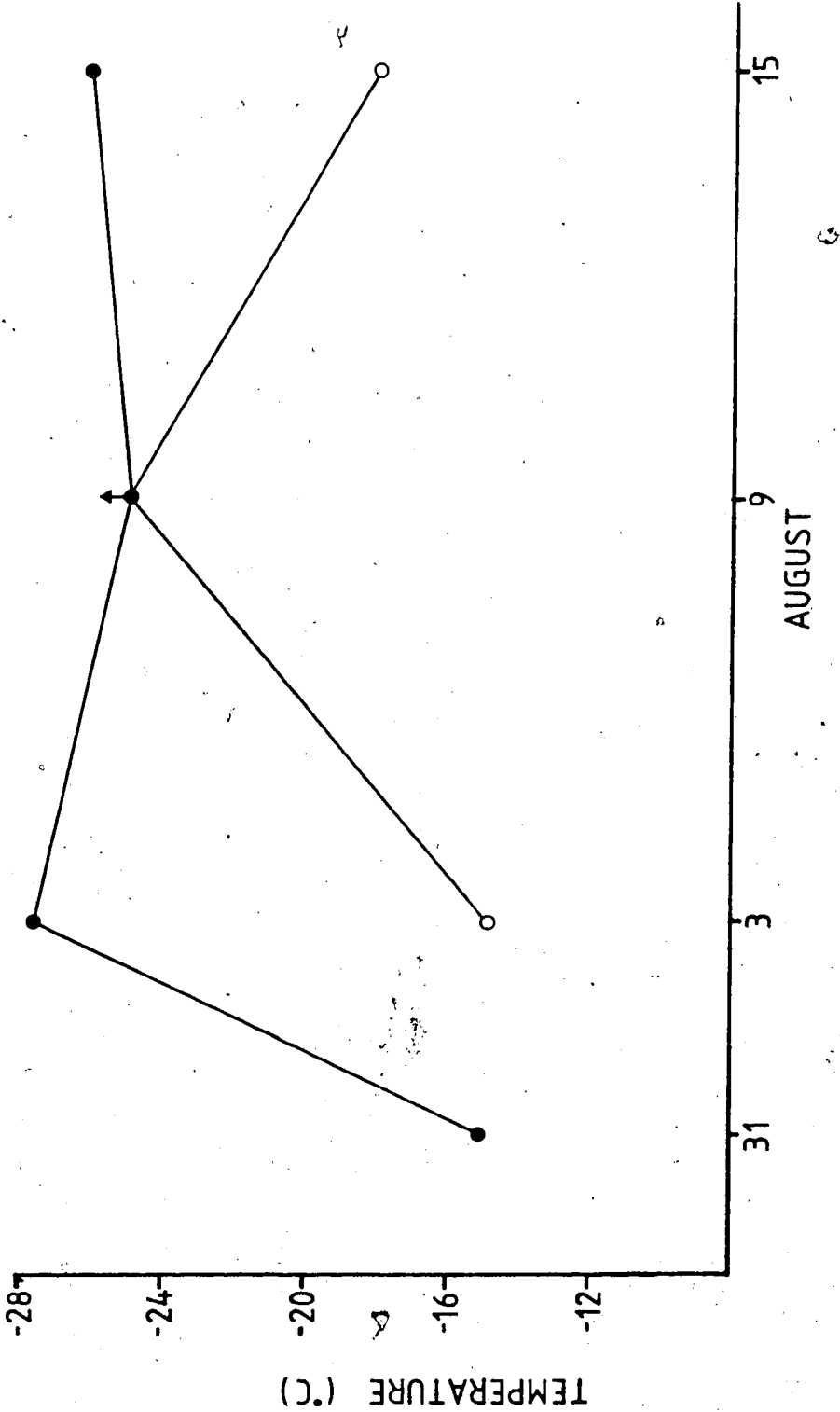

Fig. 30. Cold hardiness of *Salix arctica* stem tissue during early August 1978. Plants from the beach ridge crest (●) began and finished leaf senescence (leaf yellowing) during the period shown. Willow from the slope base (○) showed no signs of yellowing during the same time period. Arrow indicates a hardiness level greater than the lowest temperature tested.

the level of stem cold hardiness in arctic willow. There is some evidence that cold acclimation is influenced by internal rhythms alone (Howell and Weiser 1970) or rhythms along with photoperiod and/or temperature (Schwarz 1970, Siminovitch et al. 1967, McKenzie et al. 1974a, Harrison et al. 1978a).

While the discussion of the involvement of endogenous factors in the cold acclimation of *Salix arctica* is deferred to the results of the lab studies, the question of the effect of water stress on cold hardiness is relevant here.

Water stress has been shown to increase cold hardiness in apple roots (Wildung et al. 1973) and *Cornus stolonifera* stems (Li and Weiser 1971, Chen et al. 1975, Chen et al. 1977). In the latter species, water stressed plants under either long day (16 h) or short day (8 h) photoperiods showed, after 21 days, an increase in stem frost hardiness of 8° to 10°C relative to the controls (Parsons and Li 1979). Beach ridge crests on Truelove have been shown to be particularly low in soil moisture, especially as the growing season progresses and the water from snow melt is lost through evapotranspiration (Svoboda 1974, Svoboda 1977). Plants on beach ridge crests have often been found to have extremely low leaf water potentials (e.g. -2.5 to -3.5 MPa for *Dryas integrifolia*) (Addison 1977b). Moisture conditions in the sedge meadow, near the transition zone, are very favorable to plant growth throughout the growing season (Muc 1977) and leaf water potentials of *Carex stans* remained near -1 MPa (Addison 1977b). Hence, the ridge crest plants may

have experienced water stress which could have caused an increase in stem cold hardiness relative to the transition zone plants. Although tissue samples from the ridge crest were largely chosen from the plants receiving daily watering (see Phenology), it is not known whether the amount of water applied each day was sufficient to avoid stress. Since no further work was done in this area, it is unclear whether cold hardiness is induced by water stress in *Salix arctica* and adds to the apparent natural increase which occurs as dormancy begins.

3. Controlled Environment Phenology

Only the short day treatment had any apparent effect on the phenology of *Salix arctica* (Fig. 31). Since all plants were kept under control conditions (10°C/3°C) until leaf expansion was complete, the treatments were only able to visibly effect leaf senescence. Plants under short days showed the first signs of leaf yellowing 11 days after the treatment was begun, while plants subject to the remaining treatments began to senesce 4 days later (Fig. 31).

Senescence also occurred more rapidly under short days, with completion (100% yellowing) 15 days after initiation. The control and frost treatments took 20 days for the same process.

The process of senescence appeared to be drawn out in plants subjected to a far-red night (Fig. 31). If, for leaf

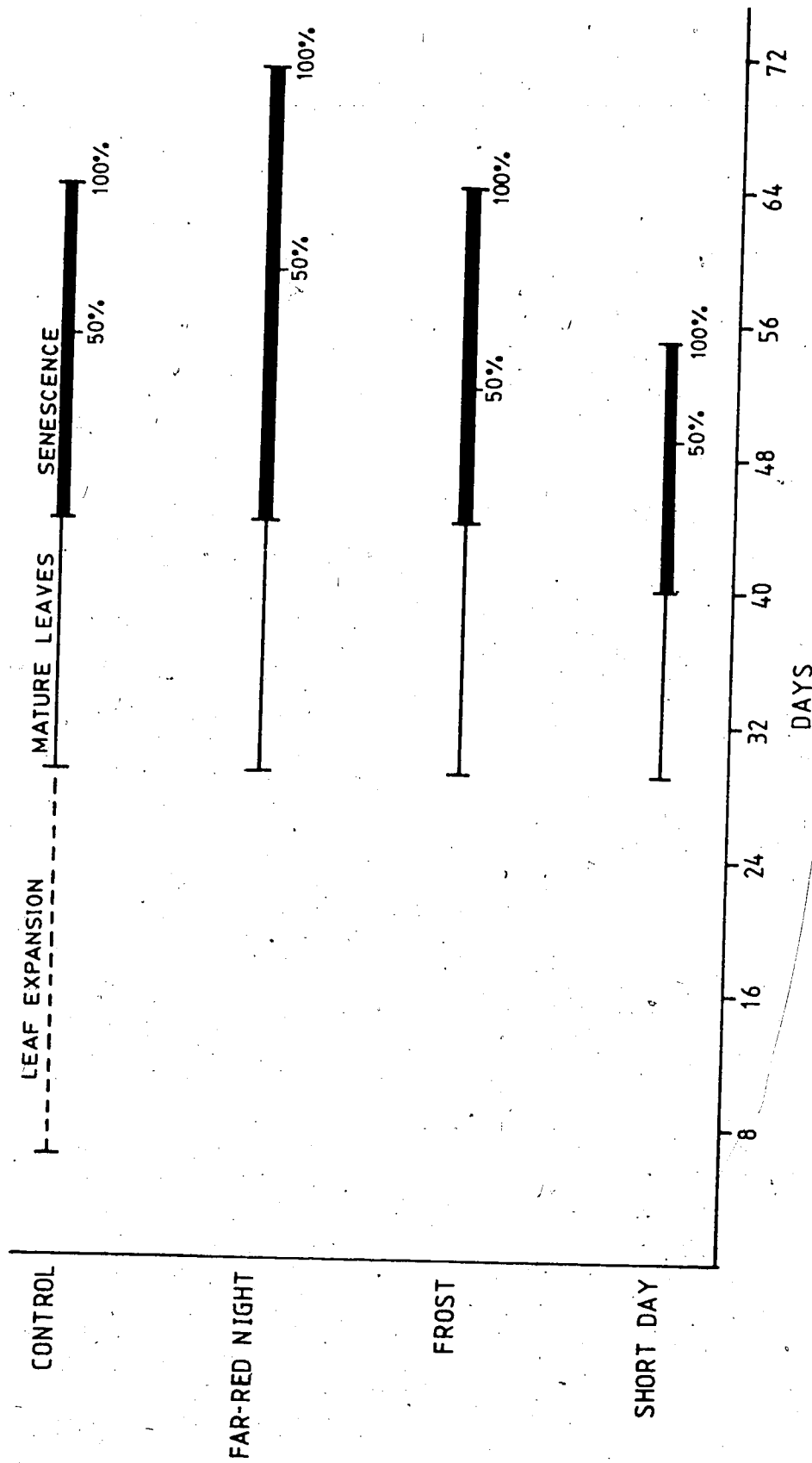

Fig. 31. Effects of the laboratory treatments on the phenology of *Salix arctica*. Leaf expansion for all plants occurred under control conditions, and plants were subsequently transferred to the appropriate treatment.

senescence, a period of far-red light can substitute for the period of inductive darkness, as it does in some flowering plants (Cumming 1969), then the results are the reverse of the predictions. However, of the four far-red treated plants, one had an anomalously delayed rate of senescence relative to the other three. Even after changing conditions to a 7°C/0°C prehardening cycle this plant still retained ca. 50% green leaves, while all the plants from the other treatments were 100% yellow. If this one plant is ignored the time of 100% yellowing in the far-red treatment occurred at about the same time as the controls.

There still remains a discrepancy between the results of the far-red treatment and short day treatment, since senescence was not accelerated in the former as in the latter. Far-red light ($\zeta=0.57$) was ineffective as a substitute for the inductive dark period of the short day treatment. Possibly ζ was not low enough or the period of treatment was not long enough. Cumming (1969) found that when the dark periods were substituted with far-red light ($\zeta=0.41$) 72 h rather than 12 h were required to obtain the same percentage flowering. In the present case, the short days only advanced senescence by about 4 or 5 days, and natural senescence may have begun before changes induced by far red light could be seen.

Therefore, the above data support a phytochrome-mediated induction of leaf senescence triggered by short days, as suggested by the field results. However, in the

field, the short day plants began to senesce 15 days before the controls, while only 4 days separated short day and control plants in the controlled environment. Also, in the field the first signs of leaf yellowing occurred 20 days after the short day treatment had begun, compared to 11 days in the controlled environment. These results reflect the different times during the growing season when the treatments were initiated, and indicate that short day induced senescence will not begin until a certain developmental stage is reached. Even though the field treatment began soon after bud break, senescence did not start until about 6 days after leaf expansion had finished. Since the stimulus (short days) had been present all along (20 days), this may mark the earliest time in development when the potential for phytochrome-mediated senescence occurs. It appears that the completion of leaf expansion is necessary before the plant is completely responsive to the short day stimulus. The controlled environment results, however, suggest that some internal changes during leaf development occur when short days are given during leaf expansion. Plants under continuous light during expansion required 11 days of short days (vs. 6 days in the field) after completion of expansion before yellowing began. It may also be for this reason that only 4 days separated the beginning of senescence under short days and control treatments in the lab, while the field control plants lagged 20 days behind the short day treated plants.

Evidence for an endogenously controlled cycle of dormancy and growth was obtained with 3 plants maintained under continuous light and warm temperatures for 10 mon. During this time all 3 plants went through 2 cycles of growth and dormancy, with the periods of activity much longer and the periods of inactivity much shorter than normally occurs in the field. After 21 short days at 1°C , the plants were placed under continuous light at 20°C for 2 mon. The temperature was then lowered to 14°C . From the initiation of the high temperatures, the plants grew for 5-7 mon, after which the leaves senesced. Often leaf senescence did not proceed in the "normal" way (green to yellow), but became brownish and necrotic directly from the green state. After 2-4 wks of dormancy, bud break occurred (temperature: 10° to 12°C) and a new activity period ensued for ca. 4 mon. Unlike the previous period, bud break began before all the older leaves were completely senescent.

The performance of the plants under the growth chamber conditions tends to support the conclusions reached from the field experiments.

4. Lab Cold Hardiness

a. Stem.

Salix arctica maintained in a dormant state at -10°C for seven months survived liquid nitrogen after slow cooling from -10°C to -25°C at 4°h^{-1} (Fig. 32). Similar results have

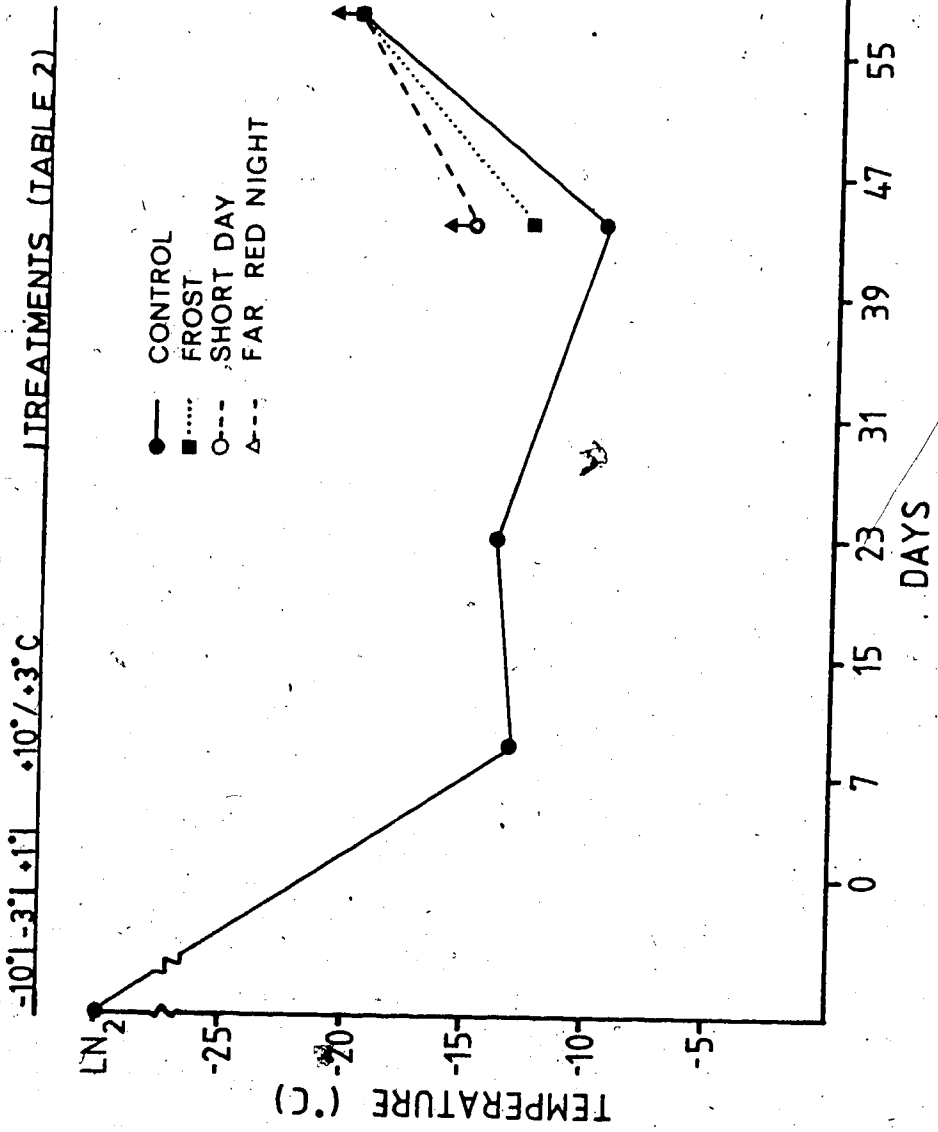

Fig. 32. Effects of laboratory treatments on the cold hardness of *Salix arctica* stem tissue. Arrows indicate a hardness level greater than the lowest temperature tested. The x-axis shows the number of days after the beginning of above freezing air temperatures.

been reported for other deciduous woody plants such as *Cornus stolonifera* (Harrison et al. 1978b), *Betula platyphylla* and *Salix sachalinensis* (Sakai 1973). In these previous cases, slow prefreezing to -15° or -20°C allowed the tissue to survive rapid freezing to -150° or -196°C . In *Salix arctica* this level of hardiness was quickly lost as active growth (bud break and leaf expansion) began. During leaf expansion, the LT 50 for stem tissue was around -13.5°C (Fig. 32). There appeared to be little change up to the beginning of leaf senescence (44 days) after bud break where stem hardiness was near -10°C . Within two weeks frost hardiness of the control plants increased to below -20°C without any change in the light or temperature environment. At this time ca. 50% leaf yellowing had occurred.

The short day and far-red treatments appeared to hasten the natural increase in hardiness by at least two weeks (Fig. 32). Plants under these two regimes became frost tolerant to below -15°C while exposed to above freezing temperatures. Willow exposed to a short frost at night was similar in hardiness to the controls over the period tested.

The minimum natural increase in stem cold hardiness near the end of the growing season of between $7-10^{\circ}\text{C}$ in arctic willow supports the contentions of other workers that endogenous rhythms are involved in cold acclimation in at least some species. Howell and Weiser (1970) found a slight increase (5°C) in the cold hardiness of apple under noninductive conditions of long days and warm temperatures.

They interpreted this as being associated with an endogenous growth cycle or changes in environmental stimuli other than temperature or daylength. Siminovitch et al. (1967, 1975) suggested that the biochemical (increases in phospholipids, soluble protein and RNA content) and structural (cell membrane augmentation) changes that occur during autumn cold hardening in *Robinia pseudoacacia*, are due to either seasonal rhythms and/or photoperiod. Schwarz (1970) concluded that internal rhythms control freezing tolerance in *Pinus cembra* and *Rhododendron ferruginum*. Supporting this are results from *Cornus stolonifera*. Harrison et al. (1978a) reported that during July through August frost treatment given after short days was unable to increase cold acclimation in dogwood past the -17°C induced by short days alone. During September and later months the same treatments increased tolerance to below -80°C .

The observed increase in stem cold hardiness of arctic willow may have been due to one of at least two processes involving rhythms. Firstly, an endogenous rhythm, completely independent of the action of any external stimuli, may begin with spring growth and after a set number of days trigger internal changes which result in hardening. A second, related, possibility is that an endogenous rhythm may control the plant's responsiveness to certain environmental stimuli (e.g. temperature) such that its occurrence at the end of the year results in increased hardening, while the same stimulus received early in the year has no effect.

The second view is supported by results from this study and others. Neither the short day nor far-red treatments would have caused a significant increase in hardness earlier than the natural hardening if an endogenous rhythm completely independent from external stimuli was operative. As well, it is likely that the FR and SD treatments affected the plants through a similar phytochrome-mediated process, as suggested for phenology (see Phenology sections). Cumming (1969) showed with *Chenopodium rubrum* that light with a low R:FR ratio and of sufficient energy to allow some photosynthesis was able to bring about induction of flowering when it completely replaced the darkness of a short day treatment. This was exactly what was found from the far-red treatment in this study, except the technique was applied to cold hardness induction rather than flowering. McKenzie et al. (1974a) reported phytochrome to be involved in cold acclimation of *Cornus stolonifera* by short days. It is possible that a very similar system exists in *Salix arctica*.

In fact, the present evidence points to the likelihood that the well supported, two-stage, cold acclimation hypothesis which Weiser (1970) has advanced to explain cold tolerance in deciduous woody trees may be valid for arctic willow in a somewhat modified form. In Weiser's scheme, the first stage involves a degree of acclimation induced by short days and relatively warm temperatures. The second stage requires low temperatures or even frost to follow the

short day treatment to attain a greater degree of hardiness (Weiser 1970, Harrison et al. 1978a). The sequence of these events is not immutable, however, as recently shown by Chen and Li (1978). Their results with *Cornus stolonifera* show that 8 h short days, low temperature (5°C/5°C day/night) and water stress independently induced greater degrees of cold hardiness (relative to the controls) and that different combinations of these factors increased hardiness as the sum of the effects of the individual factors. They concluded that each method triggered independent mechanisms of frost hardiness induction.

The above findings provide a ready explanation for the willow results. Firstly, the short day and far-red treatments may have triggered a phytochrome-mediated cold acclimation of at least 5-6°C. In comparison, *Cornus stolonifera* hardened an additional 12-13°C under short days and noninductive temperatures (Harrison et al. 1978a), and the same conditions added 15°C to the hardiness of apple (Howell and Weiser 1970). It is not known whether the short day treatment given at any time during the growing season would have increased willow hardiness, as was found with red-osier dogwood (Harrison et al. 1978a).

Secondly, low temperatures may have, a few weeks later, caused an increase in hardiness through a separate mechanism. The failure of low temperatures alone to increase hardiness early in the growing season is known for a number of species (Weiser 1970, Levitt 1972), including willow

(Sakai and Otsuka 1970). Temperatures below 10°C (usually 0-5°C) are the most conducive to hardening (Alden and Hermann 1971, Levitt 1972, Larcher et al. 1973), yet *Salix pauciflora* exposed to near freezing temperatures in July and August showed no change in stem hardness (-5°C) (Sakai and Otsuka 1970). The same temperatures in October increased hardness to -90°C. Results like these have lent support to the idea that the ability to develop freezing tolerance is inversely proportional to the stage of plant development (or phenology) (Levitt 1972). Harrison et al. (1978a), working with *Cornus stolonifera*, could not increase hardness with frost treatments until the end of the normal growing season. Their findings support the concept of seasonal variation in sensitivity to environmental stimuli. Hence, the marked change in cold hardness as a result of the frost treatment (Fig. 32) from -12.5°C to below -20°C in two weeks may be a manifestation of the seasonality in responsiveness of arctic willow to cold temperature.

It also appears likely that the frost treatment (-2°C) was unnecessarily low, and that the diurnal fluctuation of the control conditions (10°C/3°C) may have been sufficient to trigger cold acclimation. As noted above, temperatures, between 10°C and 0°C are generally most conducive to hardening when given at the proper time. The six hours of 3°C experienced daily by the control plants may have induced cold acclimation at the end of the growing season through a physiological change in the plant's responsiveness to a cold

temperature stimulus. This would explain the change in hardness in the absence of any apparent change in the environment; the stimulus had been present all along (low temperature), only a change in plant response made the difference. This can also explain why the cold treated plants and control plants followed so closely together in the development of cold hardness.

Therefore, it appears that when internal conditions are favorable low temperature can increase hardness in arctic willow, but not as early as in plants subjected to short days. This is supported by other work which has shown that although short days can induce early cold hardness, low temperatures under long days will eventually result in the same degree of hardness (Weiser 1968, Howell and Weiser 1970). Unfortunately, due to limited research material, the lower limit of plant hardness was not achieved at the end of the season and it is not known whether the short day (and far-red) and cold treated plants achieved the same level of tolerance.

5. Synthesis

Under field conditions it is apparent that the short day triggered mechanism of hardness induction is not used by the plant. The field results indicate that ridge crest plants in various stages of senescence had hardened to -27°C under continuous daylight. Since the transition zone plants

under the same radiation environment were only hardy to ca. -17°C it appears that the downward shift in zeta which accompanies lower sun angles near the end of the year (Figs. 13 and 14, pp.49, 52) is not sufficient to trigger an increase in hardiness, as occurred with the controlled environment tested plants grown under a far-red night. The large difference between the minimum observed field zeta (0.95) and that used in the controlled environment (0.57) may be the reason.

On the other hand, both the ridge crest and slope base plants may have increased slightly in stem hardiness due to lower zeta values in early August. This could help explain the difference between stem hardiness of the field plants (-17°C) and control plants grown in a controlled environment (-13.5°C). The difference in hardiness levels (3.5°C), however, is probably not significant and zeta shifts appear to play no role in cold acclimation at these latitudes in *Salix arctica*.

The higher level of tolerance in the crest plants may have been due to an earlier onset of receptiveness to the low temperature stimulus and/or due to the effects of water stress. All three (zeta shift, low temperature, and water stress) may have been involved in the development of cold tolerance in the ridge crest plants, with effects of each adding to the rest (see Chen and Li 1978).

Table 4 presents additional evidence for the case of hardiness development through low temperature alone. In

Table 4. Cold hardiness of *Salix arctica* stems in relation to phenology. Plants were collected in early August 1979 from near the 1978 study site and flown to Edmonton for testing.

Sampling Date	Hardiness Level (°C)	Phenological State
16 August	<-20	leaves green
26 August	<-32	leaves yellow-green
8 September	<-44	all leaves yellow

early August 1979, plants from the 1978 study site were collected, flown back to Edmonton, and on 10 August, placed in a constant 5°C environment with continuous light. There was no sign of leaf senescence at this time, nor six days later when hardiness was found to be below -20°C. In this test it was noticed that only older stems had survived the treatment, and first year shoots had been killed.

By 26 August leaf senescence (yellowing) had begun and hardiness was below the limit of the temperature bath (-32°C). By placing the bath in a -10°C room, the tissue was stressed to -44°C on 8 September, and survived. At this time all leaves were yellow (Table 4). Similar results involving extreme stem hardiness at above freezing temperatures were reported by Sakai (1973). He found *Salix dasycladus* and *Salix tedeburiana*, native to northern regions of Japan, to survive at least -50°C when tested in October before any frost occurrence.

There is a problem in understanding why the stem hardiness of the 1979 end-of-season plants was so much greater than those tested in the field on 16 August 1978 (<-44°C vs. -27°C). The phenology of both sets of plants appeared to be the same (complete leaf senescence) at the

time of the final sampling dates, and the air temperatures were also very similar. Between 11-16 August 1978 the mean air temperature at the study site was 4°C with a range between 2-7°C. This is quite close to the constant 5°C environment of the growth chamber plants. The environments appeared similar enough to preclude that any differences in temperatures would amount to a change in hardiness of -17°C.

There are at least two possible explanations for the discrepancy. One is that the plant root system was damaged during the 1979 transfer from the field and a disruption in the hormonal balance involved in hardening resulted. There is evidence that an interaction between gibberellins (GA) and abscisic acid (ABA) controls the degree of cold hardiness in some plants. ABA acts as a promoter and GA as an inhibitor of cold acclimation (Irving and Lanphear 1968, Irving 1969, Alden and Hermann 1971, Spomer 1979). Gibberellins have been found to be mobilized in significant amounts from the roots (Salisbury and Ross 1978), although *de novo* synthesis may not actually occur there. ABA is generally produced in the leaves. Damage to the root system could decrease GA levels enough to cause an increase in cold tolerance which would result from the amount of ABA appearing proportionately higher. Although this explanation is somewhat simplistic, it points to the very real possibility of a hormone imbalance through root damage. That root damage did occur is certain, since *Salix arctica* can have a very extensive, often interconnected, root system

which is impossible to avoid cutting when transplanting.

The second possibility arises from the difficulty of determining if both sets of plants were actually at the same stage in the hardening process, since estimates based on phenology (amount of leaf yellowing) are subjective. In addition, the degree of cold tolerance has been found to increase quite rapidly at the season's end. Howell and Weiser (1970) reported a 15°C increase in hardiness in apple over a two week period, while *Cornus stolonifera* increased 30°C in seven days under natural conditions in early November (Harrison et al. 1978a). Thus, the 1979 plants may have been in a slightly more advanced stage of hardiness development relative to the 1978 field plants, whereas both sets were assumed to be at the same stage based on phenology. The inaccuracy of the phenological cues makes this assumption questionable.

In summary, it is suggested, based on the above field and controlled environment results, that the cold acclimation mechanism presently used by *Salix arctica* involves an endogenous rhythm that regulates the sensitivity and responsiveness of the plant to temperature such that the regularly occurring low temperatures (3° to 8°C) common to the High Arctic become inductive to cold acclimation only when an internal balance of hormones is correct. These "correct" hormone levels have evolved so they do not occur too early in the season and limit the growing season such that starvation occurs during the winter, nor too late and

expose active tissue to lethal temperatures. The hormone concentrations would probably not be the same as "normal" amounts found in temperate plants because of the significantly cooler arctic environment (Spomer 1979).

The key event in determining when cold acclimation can occur appears to be snow release. Presumably, a relatively fixed chain of events occurs within the plant, following the beginning of active growth, which leads to a "readiness-to-harden" condition after a certain period of time. The fact that arctic willow can respond to changes in light quality and daylength appears irrelevant in view of the processes which are actually involved in successful cold acclimation. This phenomenon is probably a relict system which was adaptive to and inherited from the low latitude ancestors of *Salix arctica* and which still may be adaptive to present day *Salix* species at lower latitudes.

6. Field Water Relations

There was no evidence of diurnal variation in the leaf water potential of *Salix arctica* early in the growing season (Fig. 33). Values ranged from a high of -0.96 MPa at 0400 h to a low of -1.26 MPa at 2400 h. The difference of 0.3 MPa is insignificant based on the 95% confidence limits.

Studies of the daily course of leaf water potentials in arctic species (including *Salix pulchra*) from Barrow, Alaska have shown a distinct drop in water potential (ca. 0.7 MPa)

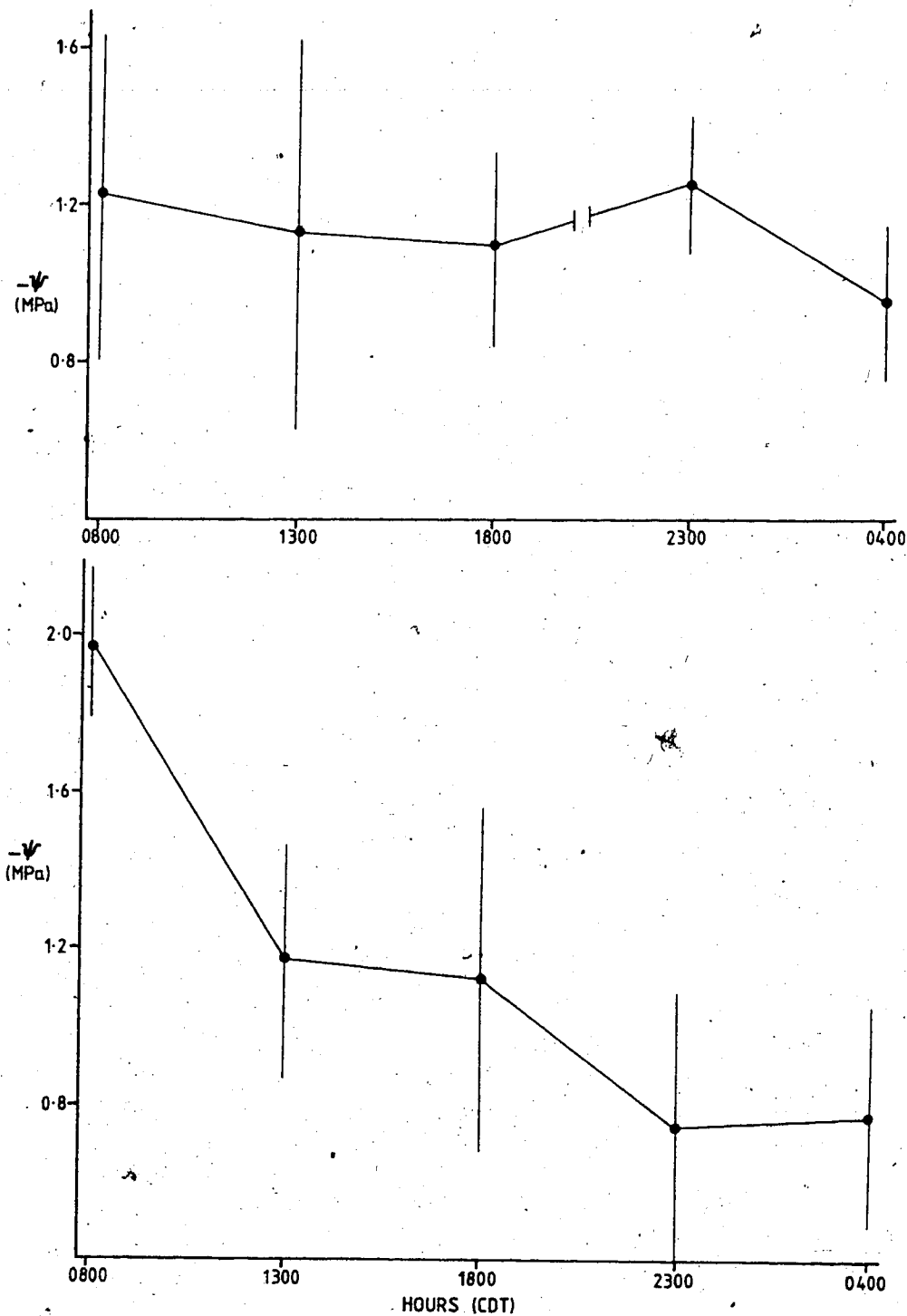

Fig. 33. Diurnal variation in leaf water potential of *Salix arctica* control plants under field conditions. Upper figure shows results from 5 (left) and 7 (right), July. Lower figure is based on 1 August data. Bars show 95% confidence limits ($n=3-5$).

near solar noon (Stoner and Miller 1975). This type of response may be expected if transpirational losses are more rapid than water delivery to the leaves. This is most likely to occur when leaf temperatures are highest and the vapor pressure gradient between leaf and air is the greatest (ie. noon). The absence of this unimodal pattern early in the season at Truelove suggests a different stomatal behavior.

Pronounced diurnal periodicity in light intensity was occurring on the lowland in early July due to very clear skies. Under these conditions, midday leaf temperatures 10-15°C above ambient often occurred, and a unimodality in transpiration and water potential would be expected.

Therefore, the absence of diurnal fluctuations in water potential is not, in this case, caused by unusual weather conditions.

The plants used in these early tests had not fully completed leaf expansion. It is possible that the stomata were not fully functional at the time of sampling (i.e. partially closed), and not reactive to environmental stimuli (e.g. light, temperature). This could result in constant and relatively high leaf resistance and, therefore, a relatively unvarying leaf water potential. Numerous workers have found diffusive resistance to be low during leaf expansion, with resistance increasing with increasing age (Solárová 1972, Jordan et al. 1975, Woodward and Rawson 1976, Rawson and Woodward 1976, Davis et al. 1977). These results have generally been interpreted as a gradual loss in the ability

of the stomata to fully open and do not support the above results. However, most studies have been conducted with agricultural forbs and graminoids, which may behave differently from woody deciduous plants. A report of the stomata of oak (*Quercus rubra*) and maple (*Acer rubrum*) showed an initial period of high stomatal resistance which was independent of light intensity during the first one to two weeks of leaf expansion (Turner and Heichel 1977).

Subsequently, response to light intensity developed and a drop in the minimum diffusive resistance occurred. A similar condition of high leaf resistance and absence of light response during leaf expansion in *Salix arctica* could explain the relatively constant water potentials noted above. The lack of porometry data precluded the testing of this idea.

Although bulk water potentials of -1.0 to -1.3 MPa (Fig. 33) are low for expanding leaves, in comparison to other studies (Boyer 1968), these values may be a reflection of the resistance to water flux through the plant and indicate the potential difference necessary to supply water to the leaves at a rate which will allow expansion to occur (Boyer 1968).

In early August a second diurnal curve was determined for *Salix arctica* (Fig. 33). Except for the reading at 0800 h the results were very similar to those from early July. The highest water potential occurred at 2400 h (-0.74 MPa) and the lowest (excluding 0800 h) was -1.17 MPa at 1300 h.

The unusually low early morning value of -1.97 MPa is difficult to explain, particularly since it differs significantly from the other results at the 95% level. One would expect the lowest leaf water potential to occur near midday when leaf temperatures are highest, VPD largest and consequently, transpiration the greatest.

In some species, generally under conditions of low to moderate water stress, increased leaf temperatures do result in decreased leaf resistance and increased transpiration (Hofstra and Hesketh 1969, Schulze et al. 1973, Batanouny 1974, Ehleringer and Miller 1975, Hall et al. 1976). However, with increasing water stress the relationship often reverses with increasing leaf temperature inducing stomatal closure and a drop in transpiration (Schulze et al. 1973, Batanouny 1974, Hall et al. 1976). If the leaf water stress results from the inability of the plant to supply water under conditions of high evaporative demand, then stomatal closure allows recharging of the leaf and a rise in water potential. This could account for a lower leaf water potential earlier or later than midday. To explain the present results it would be necessary to know the water potential below which leaf resistance begins to rise sharply (threshold potential; Hsiao 1973). Although the factors responsible for stomatal closure are varied (light, temperature, carbon dioxide concentration, bulk leaf water potential, humidity) and their interactions uncertain (Schulze et al. 1973, Hsiao 1973), threshold potentials have

been determined for a number of species and have allowed the development of a quantitative relationship between stomatal opening and leaf water status (Hsiao 1973).

Stoner and Miller (1975) reported a threshold potential of -1.40 MPa for *Salix pulchra* from Barrow, Alaska and complete stomatal closure at -2.0 MPa. Although it is not entirely justified to use the results of *S. pulchra* to interpret the response of *Salix arctica*, a threshold potential of -1.40 MPa is among the lowest reported (Hsiao 1973, Miller et al. 1978) and it is likely that the actual threshold potential of *Salix arctica* is not much, if at all, lower. With this assumption, the stomata of *Salix arctica* would be entirely closed at a leaf water potential of -1.96 MPa, implying some type of environmental stress (e.g. large vapor pressure gradient, low soil moisture). If these conditions were present at 0800 h, the leaf water potential at 1300 h should have been just as low, if not lower. This follows because on 31 July, air temperature at 1300 h was 9°C with a relative humidity of 63%, compared to 5°C and 76% at 0800 h. The total incoming solar radiation was 60% higher at 1300 h than at 0800 h, suggesting that higher leaf temperatures occurred in the afternoon. Obviously the potential for water loss was much greater at 1300 h, yet the leaf water potential was significantly lower. A good biological explanation is lacking, and in the absence of further data the results remain inconclusive.

Fig. 34 presents the seasonal variation in total leaf

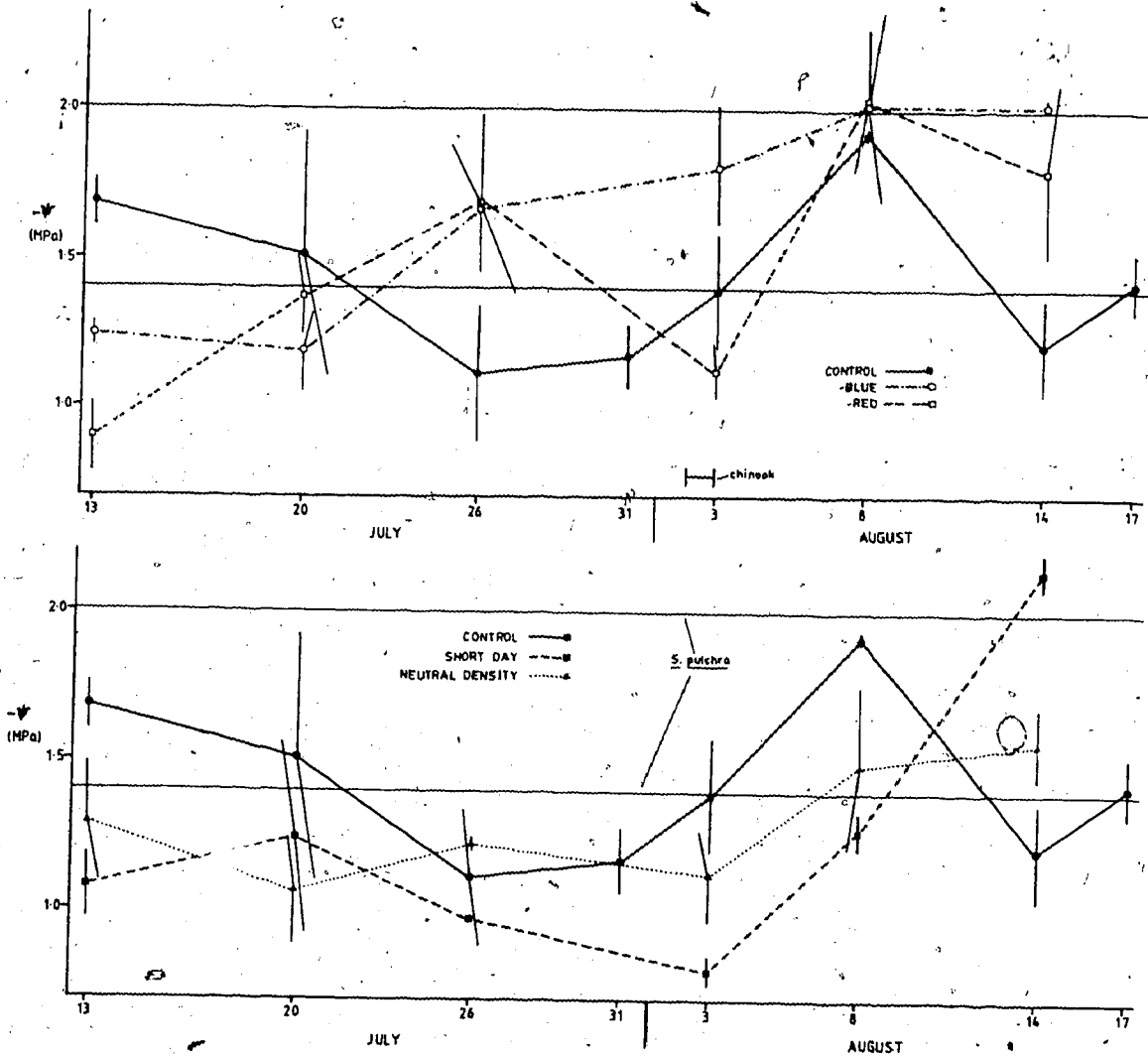

Fig. 34. Effects of field treatments on the total leaf water potential of *Salix arctica*. The threshold potential (-1.4 MPa) and point of complete stomatal closure (-2.0 MPa) of *Salix pulchra* are shown for comparison. All tissue was collected at 1300 h CDT, except on 17 August (0800 h). Bars indicate the standard error of the mean (n=1-4).

water potential for all treatments. With the exception of the short day plants, none of the treatments appeared to have significantly affected the water relations of *Salix arctica*. There was a trend towards a decreasing water potential throughout the season in some, but not all, plants. This is typified by the -blue treatment in which leaf water potential gradually dropped from -1.24 MPa in mid-July to -2.01 MPa in mid-August. Plants under the -red, neutral density and short day treatments exhibited similar trends, but differed greatly in detail.

The neutral density (ND) plants showed the least variation in midday leaf water potential, varying between -1.10 and -1.30 MPa through early August (Fig. 34). Only near the end of the season was there a modest decrease to -1.56 MPa. Often moisture was seen trapped between the inside dome surface and the two layers of cheesecloth underlying the surface, and this may have been sufficient to significantly raise the humidity of the air above the plant. Also, the cheesecloth absorbed condensation. Fig. 20 shows that leaf temperatures under the ND filter were often lower than the other treatments, although the differences did not appear statistically significant because of the large seasonal variation in temperature for any given treatment (Table 2, p. 75). The diffuse light created by the cheesecloth may have been the cause of the lower temperatures. Therefore, it is plausible that moist cheesecloth and lower leaf temperature created a local

environment which buffered daily changes in humidity and contributed to the maintenance of a relatively high and unvarying leaf water potential, through reduced transpiration. A reduction in transpiration would mean less depletion in the local soil moisture and possibly a less drastic drop in leaf water potential near the end of the season, relative to the other plants. Adding to this is the fact that the neutral density treatments were, in general, slightly closer to the slope base than the other treatments and the soil water regime there was probably more favorable for a longer period of time.

The high midday water potentials exhibited by the short day plants up to early August may have resulted from the daily 16 h covering of the plants (Fig. 34). Stomatal closure during darkness is a well-known response in most plants (Meidner and Mansfield 1968, Hsiao 1973). Under constant illumination, many arctic plants photosynthesize throughout the summer (Mayo et al. 1977, Tieszen 1978), and the stomata remain open. Consequently, transpiration occurs continuously. In contrast, the stomata of the short day treated *Salix arctica* were very likely closed during darkness, which allowed leaf water potential to rise above that of the other treatments. Leaf tissue samples were obtained 4 hours after the short day plants were uncovered, and the effects of 16 hours of tissue rehydration may have still been present at this time. A second possibility, considered further in the Synthesis, is stomatal closure in

senescent leaves.

The rapid drop in water potential over the next 11 days probably resulted from increasing leaf senescence, increasing root resistances and/or decreasing soil moisture. Short day plants at this time (3 August) had begun leaf yellowing (Fig. 27). Tyree et al. (1978) and others (Dixon 1914, Knipling 1967, Kassam and Elston 1974, Roberts and Knoerr 1977) have reported older leaves in many deciduous woody plants to have lower osmotic potentials than younger leaves. The increase in solutes often noted in senescing leaves (Pate 1975, Beevers 1976) may contribute to a decrease in osmotic potential. If, concomitantly, there is an increase in root resistance, total leaf water potential might drop significantly. Parsons (1978) found significantly higher root resistances in *Cornus stolonifera* subjected to short days, relative to long day controls, and suggested that this may be partially responsible for the decreased stem water content found during acclimation (e.g. McKenzie et al. 1974b). A similar increase in root resistance and solute concentration may have occurred in short day treated *Salix arctica*. Another possibility is a break in the water supply between leaf and stem, as many of the leaves at the last sampling were only loosely attached to the plant.

The midday leaf water potentials of plants exposed to the -red and -blue treatments were very similar throughout the season with the exception of 3 August (Fig. 34). The bulk leaf water potential of plants grown under -red light

decreased from -0.89 MPa to -1.51 MPa during mid to late July, and rose to -1.12 MPa on 3 August. Through mid August midday values decreased sharply to between -1.80 and -2.00 MPa (Fig. 34). -Blue treated plants exhibited a fairly steady decrease in total leaf water potential as the season progressed, ranging from -1.10 to -2.01 MPa.

It is not clear why the only major difference between the effects of the two treatments occurred during a chinook. At the time of sampling the relative humidity was unusually low (44%) with fairly high air temperature (10°C). This resulted in a vapor pressure deficit of 0.69 kPa. The vapor pressure gradient between the air and leaves was probably very similar, since global radiation was very low (heavy overcast) and leaf temperatures were close to air temperatures. Spot readings taken at 1100 h showed that leaf and air temperatures differed by about 0.5°C. Moderately high winds (5.5 m s⁻¹) coupled with a high vapor pressure gradient may have caused stomatal closure, resulting in slightly increased leaf water potentials in the -red treated plants.

The -blue treatment appeared unaffected by the chinook, relative to the previous sampling date (26 July: clear, calm weather conditions). The well known effect of blue light in producing stomatal opening (Meidner and Mansfield 1968) is not evident in this case, since the response is in the wrong direction. In addition, blue light has been found to be effective at very low light intensities (1.3 J m⁻²s⁻¹) and

is probably not important in the normal opening and closing mechanism (Meidner and Mansfield 1968, Zelitch 1967).

An alternate, very tentative, explanation is that prolonged growth in an environment deficient in blue light disrupted normal stomatal function, possibly causing them to be less responsive to closure-inducing conditions.

Voskresenskaya (1972, 1979) reported that plants grown in red light preferentially accumulate carbohydrate (especially starch) in contrast to plants grown under blue light, where nucleic acids and proteins are favored. Also, less active chloroplasts with easily disrupted membrane systems are formed under prolonged red light treatment. This may have impaired stomatal function.

Since there were no other signs of detrimental effects of a high red-low blue light environment (e.g. premature leaf senescence, very pale leaves), the above suggestion remains tentative at best. However, with the majority of the results of the -red and -blue light treatments in close agreement throughout the season, it is clear that the two environments produced no long term differences in leaf water potential which were mediated through a phytochrome system.

The midday leaf water potential of the control plants remained relatively stable throughout July (Fig. 34). The low value obtained on 13 July (-1.68 MPa) may have resulted from low soil moisture, as there had been no precipitation for two weeks (Fig. 26). With more rain, midday leaf water potentials generally remained below -1.40 MPa (threshold

potential of *Salix pulchra*; Stoner and Miller 1975). Assuming, as before, that *Salix arctica* and *S. pulchra* have similar threshold potentials, it appears that the plants rarely experienced significant water stress throughout the season. A major exception occurred on 8 August, with a mean midday leaf water potential of -1.92 MPa (Fig. 34). Weather conditions at this time were not unusually stressful, and there appears no clear reason for such low values, particularly since the two subsequent tests showed much higher bulk water potentials. If this point was in error, midday leaf water potentials remained relatively constant to near the end of the season.

The problem of variability in the data lies partially in the poor performance of the psychrometers at low temperatures ($< 10^{\circ}\text{C}$). The range of voltage output over a given range of water potentials becomes much smaller at low temperatures, and consequently resolution becomes much poorer. At 5°C a difference of 0.2 μvolts can mean a 0.4 MPa difference. At 15°C the same difference corresponds to ca. 0.1 MPa. Compounding the temperature problem is the change in sensitivity and performance of an individual psychrometer over time. Although an attempt was made to address both problems through the use of calibration curves at different temperatures and times, questionable assumptions such as a linearity of change between different times and temperatures were necessarily made, which introduced an unknown amount of error.

7. Controlled Environment Water Relations

Throughout the growth chamber experiments the bulk leaf water potential of the control plants remained fairly constant (Fig. 35). From two weeks after bud break (i.e. during leaf expansion) to well into leaf senescence, the mean leaf water potentials ranged between -0.71 to -0.98 MPa. None of the values differed significantly at the 95% level.

In the control plants, the osmotic component of leaf water potential decreased markedly as the leaves matured and began to senesce. The mean value during expansion was -1.23 MPa, while just prior to and during senescence (24-34 d later) the osmotic potential averaged -2.10 MPa. Turgor pressure also increased as senescence approached, as directly implied by an unchanging total water potential under conditions of decreasing osmotic potential (Fig. 35). The mean pressure potential appeared low during leaf expansion (0.32 MPa), but increased to between 1.14 and 1.23 MPa in mature and senescing leaves.

The far-red, short day and frost treatments did not appear to affect any component of leaf water potential in a significant way (Fig. 35). There is the suggestion of an increase in bulk leaf water potential in the short day plants, from -0.72 to -0.45 MPa, but these values do not significantly differ from the other treatments sampled at the same time. On day 38 the mean leaf water potentials were -0.98, -0.86, -0.84 and -0.72 MPa for the control, frost

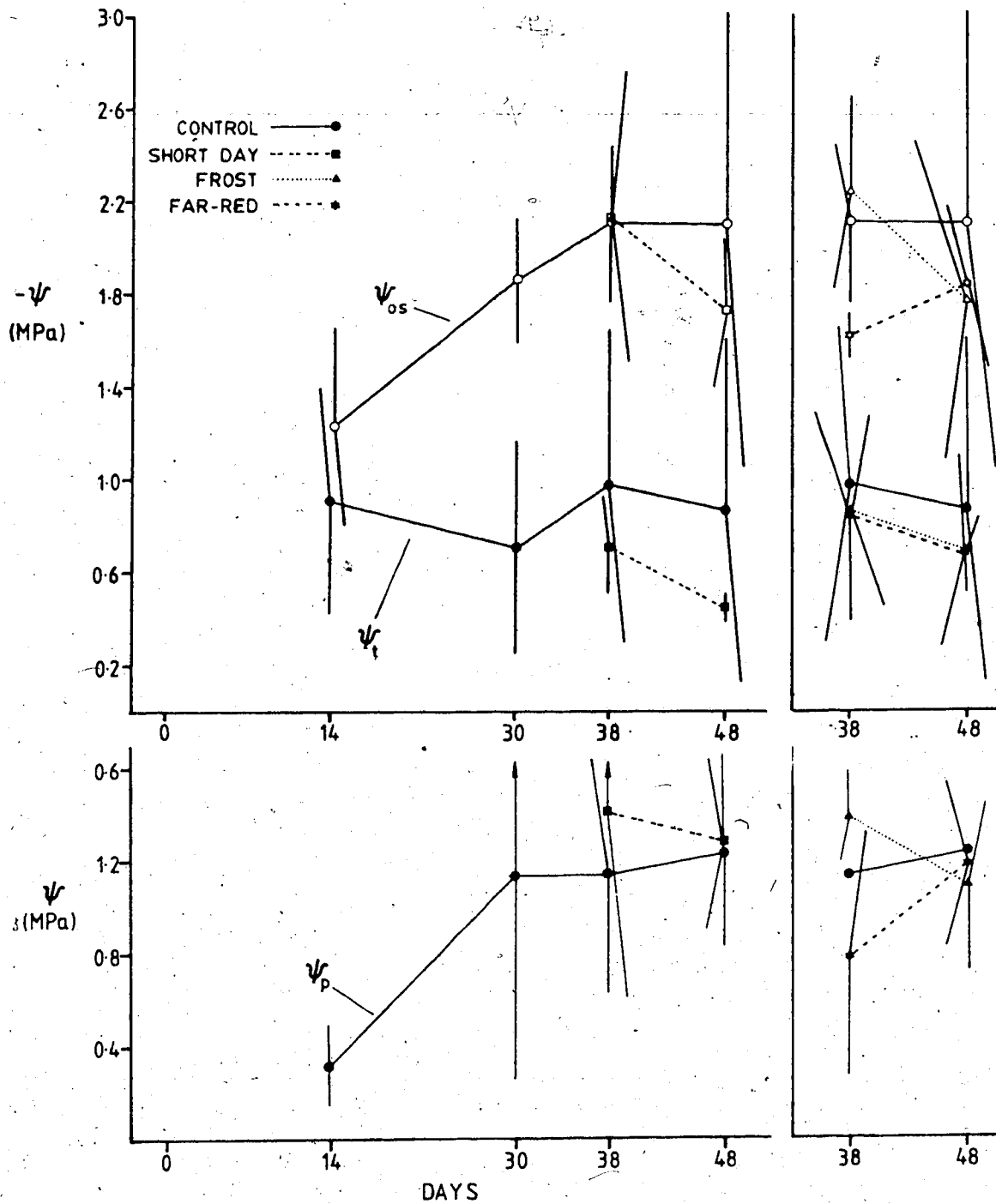

Fig. 35. Effects of controlled environment treatments on the leaf water potential of *Salix arctica*. Day 0 marks beginning of above freezing temperatures. In upper figure, closed symbols indicate total leaf water potential; open symbols show osmotic potential. Turgor is shown in lower figure. 95% confidence limits are given ($n=2-4$).

treated, far-red and short day plants; respectively. Ten days later the water status of all the treatments was essentially unchanged. The mean leaf water potentials had increased 0.10 to 0.27 MPa in all cases, but the changes were insignificant.

The mean osmotic components of the SD and frost treated plants may have increased as leaf senescence progressed (by 0.40 and 0.47 MPa; respectively), but the variation in results was too great to permit statistical significance. Over the 10 day period, the far-red plants showed a statistically insignificant decrease in mean osmotic potential (0.22 MPa). The lack of any effect of the treatments is apparent in the fact that after 19 days the mean leaf osmotic potentials of all the plants were within 0.11 MPa of each other. The greatest difference (0.37 MPa) was between the control and short day plants (-2.10 and -1.73 MPa; respectively). No differences were statistically significant. At the time of the last sampling the plants were in stages of senescence ranging from 1/2 to 3/4 yellowed leaves (short day) to 1/4 or less (far-red treatment).

The mean turgor pressure of the SD plants did not significantly change between the two sets of readings (1.41 MPa to 1.28 MPa). The frost treated and far-red plants showed large apparent changes in magnitude (0.31 and 0.40 MPa; respectively) but were also statistically insignificant because of wide variation in values. The final set of

readings for the control and all the treatments was within a 0.20 MPa range, between 1.08 and 1.28 MPa (Fig. 35).

In some cases the wide confidence intervals disallowed comparisons which otherwise appeared important. It was later noted that some of the dispersion between readings was not due to problems with psychrometers or other procedural difficulties, but to between-plant variation within a given treatment. For example, two psychrometers used to sample plant #3, subjected to daily frost, gave readings of -0.63 and -0.64 MPa. A second plant, under the same conditions, gave water potentials of -1.08 MPa from two different psychrometers. The two data sets combined resulted in much wider confidence limits than would occur from either set alone.

Although this sort of disparity was not the rule, damage during transplanting, particularly to the roots, is probably one important factor partially responsible for variation in water potential. Another is the difference in general vigor between plants, noted particularly in *Saxifraga oppositifolia*, both in the field and in growth chamber studies.

Despite such problems, a clear distinction was found between the osmotic and turgor potentials of expanding leaves, and the same component potentials in mature or senescent leaves. The low mean turgor in expanding leaves (0.32 MPa) implies that the threshold turgor was low and, therefore, that the cell wall plasticity was high. Threshold

turgor is the pressure potential that must be exceeded for cell growth (through irreversible wall extension) to occur (Hsiao 1973). Because leaf expansion was occurring, the mean threshold turgor must have been less than 0.32 MPa. This value is somewhat lower than found in previous studies.

Turgor pressure of 0.4 to 0.8 MPa were associated with leaf enlargement and hypocotyl growth in cultivated species (corn, soybean, sunflower, oats) (Cleland 1967, Boyer 1968, Boyer 1970, Meyer and Boyer 1972).

The water potential of the expanding leaves was also low (-0.91 MPa) in comparison to the agricultural species mentioned above (> -0.4 MPa). Since the steepness of the water potential gradient between the water supply and the tissue depends on the resistance to water flow (Boyer 1968), it appears that this resistance in *Salix arctica* tissue is fairly high. The insignificant changes in mean bulk water potential of the control plants throughout the growing period suggest a relatively constant water flow resistance during that time. The radiation and temperature environments cycled regularly and the soil was well watered. If, while the mean osmotic potential of the leaves decreased, the resistance to internal water flow remained the same, then turgor would necessarily increase and return the potential gradient to near -0.90 MPa. This assumes little or no change in water loss to the atmosphere.

The low osmotic potentials (-1.85 to -2.11 MPa) which prevailed in *Salix arctica* leaves during the growing period

may have been sufficient, along with adequate resistance to a limited amount of freeze-dehydration stress, to account for the degree of frost hardiness measured in the leaf tissue. Levitt (1957, 1959, 1972) reported his results on the effects of infiltrated sugars on the hardiness of cabbage and found a calculated killing temperature (based on the osmotic potentials of the cell sap) of -9°C for tissue with cell osmotic potentials between -1.86 and -2.00 MPa. These values are very close to those found in the present growth chamber experiments, both with respect to the leaf osmotic potentials and leaf cold hardiness. Cold hardiness of willow leaves was estimated from leaf disk survival tests to be -7.0°C under growth chamber conditions. However, Levitt's results could only be used as support for the present study if the degree of tolerance to freeze-dehydration stress was the same in cabbage and *Salix arctica*. The above osmotic potentials do not protect tissue through simple freezing point depression.

8. Synthesis

The absence of significant changes in the total leaf water potential of the growth chamber control plants suggests that the field grown controls behaved similarly, and therefore the 8 August data were probably erroneous.

The mean leaf water potential of plants in the field during the last month, excluding the 8 August data, was

lower (-1.30 MPa) than in the plants grown in the growth chamber (-0.87 MPa). In both cases visible leaf senescence was evident at the time of the last sampling. A greater resistance to water flow in the field plants, together with a greater evaporative demand, may have contributed towards a lower leaf water potential throughout the season. If the threshold potential of *Salix pulchra* (-1.40 MPa) is applied, the field plants were operating, on the average, just below threshold level. Although root resistances of some arctic and alpine species have been found to be unaffected by changes in soil temperature (Stoner and Miller 1975, McNaughton et al. 1974), these studies tested herbaceous plants only. However, higher evaporative demand alone may have accounted for the differences between the two sets of plants.

The osmotic potentials from the field plants were not reported because the results were often incomplete (psychrometer failure), contradictory, or obviously wrong (e.g. negative turgor). The problems were probably partially related to the field use of liquid propane (which left an odiferous residue) for the freeze/thaw procedure. However, the osmotic potentials of the control plants which did produce results were generally between -1.50 and -2.20 MPa. These values are in the same range as the growth chamber plants, and allow the same conjecture, mentioned earlier, that leaf cold hardiness in *Salix arctica* may be due to a combination of slight freezing point depression and a certain degree of dehydration tolerance (Levitt 1972).

Whether the maintenance of a high solute concentration was specifically selected for as a mechanism for increasing frost tolerance, or is simply the fortuitous result of other physiological constraints (e.g. carbon fixation exceeding translocation) is unknown.

With the possible exception of the short day regime, none of the treatments affected the leaf water potential in ways that could be clearly associated with cold hardiness or to the operation of a phytochrome-mediated system. Under both ~~field and growth chamber~~ conditions, the short day plants tended to have similar or slightly higher leaf water potentials than the controls. This appeared most clearly during the early to middle period of leaf senescence. The field plants on 3 August and the growth chamber plants on the last sampling date were at approximately the same phenological state and both showed high leaf water potentials relative to previous samplings. Subsequently, the field plants dropped rapidly in water potential, probably due to disruption of water flow and leaf abscission. Previous research with deciduous trees has shown a significant increase in leaf resistance (through stomatal closure) with the onset of leaf senescence (Gee and Federer 1972, Hinckley et al. 1978) and this may explain a rise in leaf water potential near the end of cold acclimation by short days in *Cornus stolonifera* (Parsons 1978). A similar increase in leaf resistance in *Salix arctica* under short days may account for the brief increase in leaf water

potential of the senescing leaves, seen in the growth chamber and field studies. A limited amount of porometry data does not support this idea. The stomatal resistance of green leaves from untreated plants in the controlled environment chamber was very low ($3.5 \pm 1.1 \text{ s cm}^{-1}$; 95% confidence limit) near the end of the growing period. At the same time, two senescent leaves (yellow-red) had slightly higher stomatal resistances (6.5 and 5.4 s cm^{-1}). Assuming the same results from leaves senescing under short days, this slight change does not compare well with the reports of the above workers, who found increases of 40 s cm^{-1} or more. Further readings from senescent leaves of *Salix arctica* are necessary for more meaningful comparisons.

It would be expected that as leaf senescence progressed in the controls and other treatments, the pattern of leaf water potential would be similar to that of the SD plants. However, in the field, the -red and -blue treatments showed much lower leaf water potentials than the control plants while at approximately the same phenological state. There is no clear explanation for this except that, as mentioned earlier, soil moisture may have been limiting near the end of the growing season for plants sheltered from the rain by the domes. Also, the control plants and neutral density regime were further down slope, near the meadow, and may have been under more favorable moisture conditions at the end of the season.

In general, the water relations of *Salix arctica* appear

to be affected more by the state of phenology than by any other factor. Short days hastened senescence which resulted, at first, in slightly increased leaf water potentials, followed by lower water potentials, probably through disrupted water flow. Throughout the growing season, field plants near the ridge slope-meadow transition zone probably experienced no severe midday water stress, to the extent that stomata closed completely. Conditions were not optimal in the field, though, since higher water potentials were found in well watered plants under controlled environments.

D. Saxifraga oppositifolia

1. Phenology

The effects of the field treatments on *Saxifraga oppositifolia* were very similar to those found for *Salix arctica*. None of the four treatments appeared to significantly affect flowering phenology in saxifrage (Fig. 36). The time period between the greening of the shoot tips to the senescence of the second year leaves was similar for all except the short day treatment. The control, -red, -blue, neutral density and short day treated plants averaged 37, 39, 38, 41 and 23 days, respectively. In addition to the shorter growing period, plants under short days did not exhibit shoot expansion (Fig. 36).

These results point to the same explanation offered for the *Salix* data. *Saxifraga oppositifolia* is often the first species to flower after snow melt, since dormancy

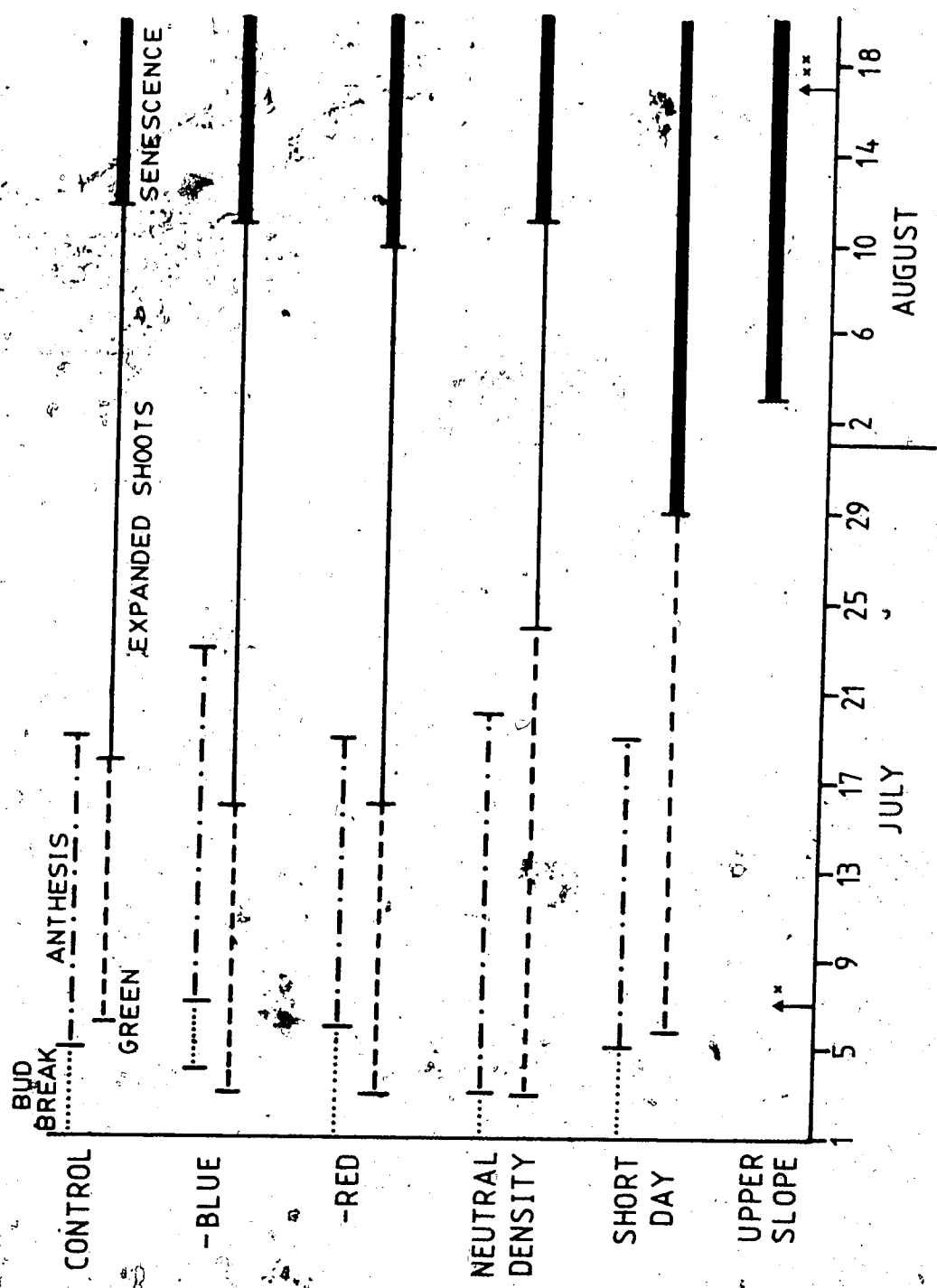

Fig. 36. Effects of experimental treatments on the phenology of *Saxifraga oppositifolia* during 1978. The upper slope results are explained in the text. (x): initiation of short days; (xx): first sunset.

breaks at -2°C and flowering can occur at 0°C (Svoboda 1977, Parker 1977). The period of activity (ca. 39 d) in this species appears to be very similar to that of arctic willow. As the SD plants had a shorter growth period, it is suggested that a "relict" phytochrome-mediated system for anticipating winter may exist in arctic populations and even be functional in lower latitude alpine populations. *Oxyria digyna* was found to exhibit ecotypic variation in photoperiod with respect to flowering (Mooney and Billings 1961) and the same may be true in *S. oppositifolia* (and *Salix arctica*) with regard to dormancy.

A small group of saxifrage plants was watered on a daily basis, as with willow on the ridge crest, but were situated on the upper slope of the beach ridge. The first signs of leaf senescence occurred on 3 August, 7 d after the watered willows (Fig. 36). Since the estimated period of activity is the same in the two species (40 d for willow and 39 d for saxifrage), the saxifrage plants may have simply become snow free at a later date than the *Salix*. This is likely because the saxifrage was slightly downslope from the crest and in a small depression. Thirty-nine days prior to 3 August is 24 June, and with 3-5 days needed for flowering and shoot tip greening, the approximate time of snow release was 20 June. This is plausible given the rate of snow melt recorded for the lower part of the slope in early July 1978 (Fig. 19).

The field data support the hypothesis presented earlier

that a biologically fixed growing period occurs within at least some high arctic plants and that the response elicited by short days may be a relict retained from lower latitude populations where such a system is still adaptive.

Unfortunately the leaf senescence phenology observed for plants grown in the controlled environment was quite different from and contradictory to the field results. Essentially all the plants (control, far-red night, and frost treated), except those under short days, had evidence of senescence of second year leaves at the time of the establishment of the treatments (29 d after thaw). The short day plants began senescence 11 days later. It is obvious that, in this case, the treatments played no role in the onset of senescence, since leaf yellowing had begun the same day or before the experimental regimes were set up. Also, the rate at which the plants attained 100% yellowing was often quite variable (10-15 d), even between plants within the same treatment. Possibly the air temperature was too high (10°C), accelerating the senescence of the second year leaves, independent of the treatment effects. Also, the light intensity may have been too high over an extended period of time, also accelerating senescence. It was noted that *Salix arctica* under the same conditions often developed reddish-green leaves which are not normally seen in the field. This may have been an increase in anthocyanin in response to high light.

Due to the inconsistent response and uncertainty of the

cause, no interpretation of the phenology of the controlled environment grown saxifrage is attempted.

2. Cold Hardiness

Due to a shortage of plant material only three tests were able to be conducted during the 1978 season. Only shoot tips were used in the tests and consequently a heavy amount of destructive sampling was involved to obtain the 50 mg of tissue needed for each test.

Fig. 37 presents the results of those tests. The hardiness level remained high under all treatments except the -blue during the three week period between 24 July and 13 August. The control plants ranged between -15° and -18.6°C . The neutral density treatment gave similar results. The short day treated and -red treated plants were consistently more hardy than the lowest test temperatures of -15° or -20°C .

In the absence of data from lower stress temperatures it is difficult to separate the effects of the SD and -red treatments from the control and ND regimes. As noted in the discussion of *Salix arctica* cold tolerance, short days have been found to be effective in increasing the degree of cold hardiness in a number of woody plants (Weiser 1970). Since this implies a phytochrome-mediated mechanism of hardiness development, the shift in zeta created by the -red dome may have triggered a similar increase in hardiness. The

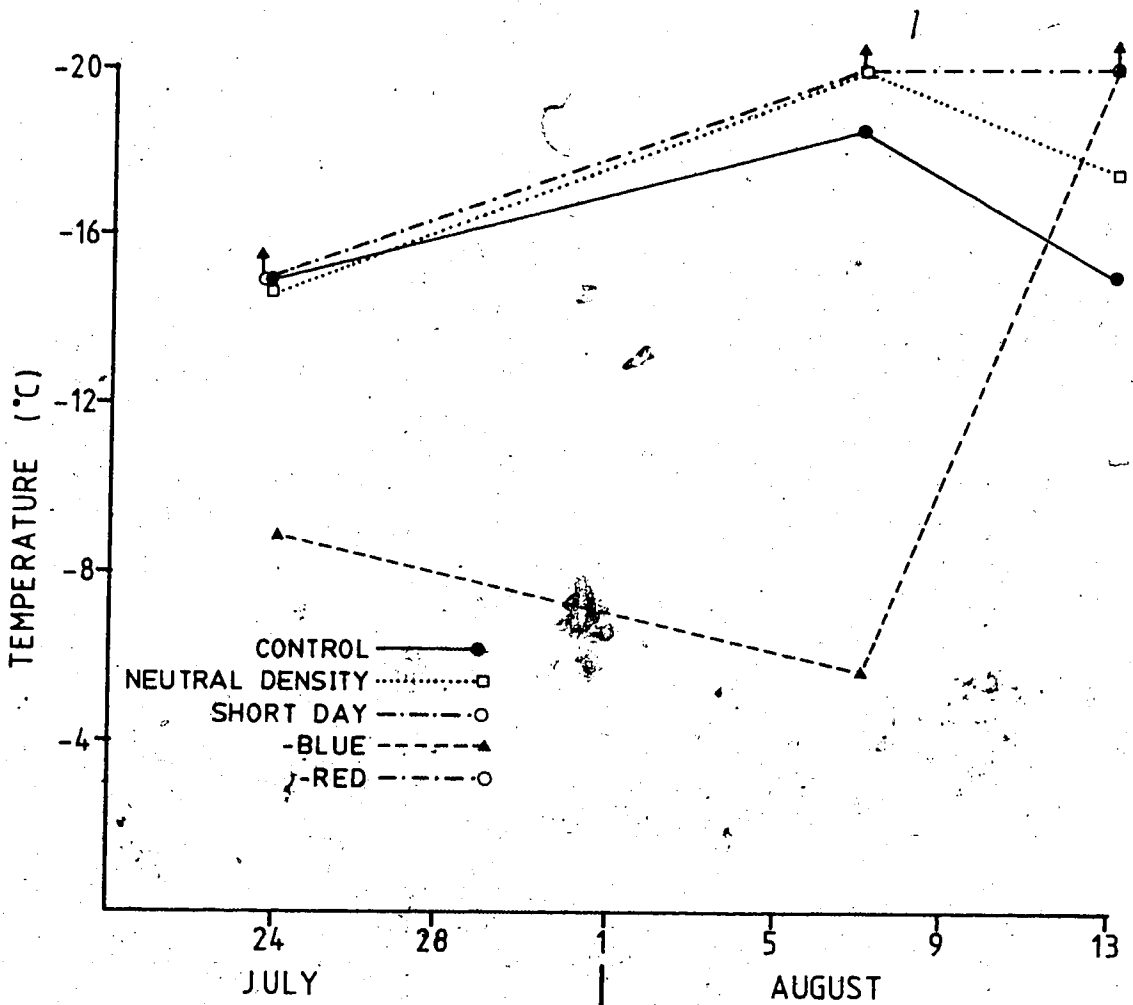

Fig. 37. Cold hardiness of *Saxifraga oppositifolia* as affected by the different field treatments. Arrows indicate a level of hardiness greater than the lowest temperature tested. The short day and -red treated plants exhibited the same pattern of hardiness for the first two trials. There was insufficient material to test short day plants a third time.

possibility of this occurring was discussed in the section on radiation. However, the lower limit of temperature tolerance was not established for these two treatments and their effectiveness in increasing cold hardiness remains unclear.

The -blue treatment appeared to decrease cold tolerance markedly, relative to the other treatments (Fig. 37).

Between 24 July and 7 August, hardiness was between -8.8° and -5.6°C . In the next week, an increase in hardiness to below -20°C was noted. The apparent increase in frost tolerance of more than 14°C in one week in the absence of any significant temperature changes cannot be explained by any known cold hardiness mechanism. It is suggested that the unusually poor cold tolerance exhibited by the -blue treated plants was a secondary effect resulting from a long term high red light-low blue light environment.

Plants which have been photosynthesizing under red light ($\Delta\lambda=670-680\text{ nm}$) for a prolonged time period preferentially accumulate carbohydrate (particularly starch). Under blue light ($\Delta\lambda=460-470\text{ nm}$) biosynthesis of protein, nucleic acids, phospho-organic compounds (e.g. ATP) and chlorophyll is activated, and carbohydrate synthesis is inhibited (Voskresenskaya 1972, 1979). Less active chloroplasts are formed under red light and there is limited gas exchange, weak photophosphorylation, and reduced electron transport. As well, growth under red light limits biosynthesis of enzymes that are important in carbon

metabolism inside and outside the chloroplasts, therefore upsetting normal photosynthesis. Transfer of red light grown plants to blue light will reverse these effects

(Voskresenskaya 1972, 1979).

This general decrease in the efficiency of carbon metabolism and shift in emphasis during synthesis when plants are grown under red light may account for the poor cold tolerance that was found. Cold acclimation is an active metabolic process which has been found to involve an increase in soluble proteins, nucleic acids, sugars, and changes in membrane composition and structure (Siminovitch et al. 1968, Mazur 1969, Weiser 1970, Levitt 1972). Plants developing in an environment poor in blue light may lack the proper amount or types of these substances which would normally allow greater low temperature resistance. Obviously the decreased level of blue light was not detrimental enough to entirely disrupt normal development, since a phenology similar to that of the control was observed (Fig. 36).

However, the possibility of a decrease in hardiness due to internal changes in the leaves cannot be ruled out. For example, there may have occurred a decrease in membrane permeability to water which would not seriously affect normal cell function, but significantly restrict rapid water efflux during freezing. This is essential in order for the cell to avoid intracellular damage by ice crystals. This might occur as an indirect result of reduced protein or nucleic acid content.

There is indirect evidence for the direct effect of blue light on changes in membrane permeability. Differences in cell membrane permeability have been suggested as an explanation for the polar transport of auxin (Raven 1975, Goldsmith 1977). Since there is evidence that blue light can inhibit polar auxin transport (Dennison 1979) and also that the blue light photoreceptor is located in the cell membrane or near the cell wall (Voskresenskaya 1972, Dennison 1979), it is possible that permeability of the plasma membrane to auxin is directly controlled by blue light (Dennison 1979). How the effect of blue light on auxin transport can affect cold tolerance is obscure, but the example serves to illustrate the possibility of photocontrol of membrane permeability. Whether this is the reason for the low cold hardiness found in *Saxifraga oppositifolia* under a blue poor environment is not known.

The rapid rise in hardiness in the -blue light plants between 7 August and 13 August may have been due to endogenously controlled metabolic changes accompanying the beginning of senescence (second year leaves) and dormancy, as suggested for *Salix arctica*. However, the control plants did not increase in hardiness despite a phenological state similar to the -blue treated plants. Possibly the end-of-season changes which occurred in plants under the -blue treatment were sufficient only to restore the degree of cold hardiness back to normal, and that *Saxifraga oppositifolia* does not undergo a natural increase in

hardiness as early as *Salix arctica*. Therefore, greater cold tolerance would not yet be evident by 13 August.

That higher degrees of tolerance do eventually develop is clear from the fact that monthly mean soil surface temperatures during the winter on Truelove descend to -35° or -40°C (Courtin and Labine 1977). Kainmüller (1975) showed that alpine populations of *Saxifraga oppositifolia* undergo a marked increase in cold hardiness as the growing season ends. She found that during the summer the potential cold resistance of leaf tissue was between -5° and -10°C , while in October the same tissue survived slow cooling to -50°C or lower. The shoots were resistant to between -15° and -20°C during the growing season and reached -60°C or lower in the winter. Both tissues were less resistant by about 5° when stressed by rapid freezing. She did not consider what the mechanism of hardiness increase might be.

The results of Kainmüller (1975) compare favorably with those of this study. Since the absorbance of the TTC dye was correlated with regrowth from the stressed stem, and not with survival of leaves *per se*, the test as used in this work actually evaluated the cold hardiness of the stem and buds. Hence the -15° to -20°C range reported by Kainmüller for potential shoot cold hardiness is essentially the same range illustrated in Fig. 36 (excluding the blue treatment).

The controlled environment results indicate a lesser degree of hardiness than that found under field conditions

(Table 5). Plants which had been stored at -10°C were hardy to below -25°C , but did not survive immersion in liquid nitrogen. Kainmüller reported alpine *Saxifraga oppositifolia* to be cold hardy to below -196°C during the winter. This suggests that the failure to find the same in this case may have resulted from a poor choice of shoots, since it is difficult to select live from dead shoots when the plant is in the frozen state. Also, -10°C may not be cold enough to develop a very low degree of tolerance in this species.

During the growing season, the control plants were hardy to between -8° and -10°C . Most plants subjected to the various treatments exhibited similar degrees of cold tolerance. The exception is the short day plants which were cold hardy to below -20°C at the time of the last test (Table 5).

Short days may have caused an early increase in hardiness in a manner similar to that which occurs in other species (Weiser 1970) and as suggested for *Salix arctica*. Unlike the results with arctic willow, the far-red treatment failed to increase hardiness in *Saxifraga oppositifolia*. This may have resulted from a difference in the phytochrome threshold point or the requirement for a longer induction period to obtain the same degree of response as that which occurred under short days (Cumming 1969).

The lower hardiness levels of the controlled environment grown plants in comparison to the field results is difficult to explain. Water stress has been shown to cause a slight increase in hardiness (Chen et al. 1977) and

Table 5. Cold hardiness ($^{\circ}\text{C}$) of *Saxifraga oppositifolia* in response to the laboratory treatments. The left column indicates the number of days of above freezing air temperature. The temperature and light regime for each treatment are given in Table 1. Plants on day -6 were from a constant -10°C environment. The treatments were started on day 29. Values given as a temperature range are from direct observations of shoot survival two weeks after temperature stress.

Day	Treatment			
	Control	Short day	Far red	Frost
-6	<-25			
23	-8.4			
44	-9.4	between -10 and -15	between -10 and -15	-9.3
58	between -10 and -15	<-20	between -10 and -15	between -10 and -15

the growth chamber plants had a more favorable moisture regime than the field plants (compare Figs. 39 and 40). There were greater differences in leaf water potential between the different field treatments than between the control plants from the growth chamber and the field control plants, whereas the magnitude of hardiness differences was greater between field and lab control plants than between different field treatments. However, hardiness is not linearly related to water stress. With red osier dogwood, Chen et al. (1977) found a significant increase in hardiness (from -3° to -6°C) as water potential decreased from -0.5 to -1.4 MPa, and a similar increase when water potential further decreased to -1.7 MPa (-6° to -11°C). It is

possible, then, that the field plants experienced a slight hardiness increase because of water stress.

Higher shoot temperatures were probably not responsible for the lower hardiness of the controlled environment plants. Plants receiving nightly frosts, which field plants rarely experienced, appeared no more cold hardy than the controls (Table 5). One important difference between field and controlled environment plants, though, may have been root temperature. The field plants had daily mean subsurface (-5 cm) root zone temperatures between 4-5°C (Table 2, p. 75), with values probably dropping a few more degrees at "night". Although the soil temperatures of the controlled environment plants were not measured, they were very likely near the 10°C air temperature which persisted 16 h each day. It is quite possible that a 5 to 6°C increase in root temperature, relative to the shoots, could result in significant hormonal changes in plants adapted to cold temperatures (see Spomer 1979). In particular, gibberellic acid (GA) may be translocated from the roots in significant amounts (Salisbury and Ross 1978), and has been found to be involved in the decrease of cold hardiness (Irving and Lanphear 1968, Alden and Hermann 1971). If the GA levels became abnormally high in the shoots due to increased transport from unusually warm roots, a decrease in hardiness might occur. Since hormones may act primarily on altering membrane permeability (Trewavas 1976), a decrease in the membrane permeability to water would result in increased

intracellular damage through ice formation. Cytokinins may also be involved. Artificial cytokinin (kinetin) has been found to greatly reduce the water permeability of roots (Tal and Imber 1971, Collins and Kerrigan 1974, Collins 1974). Higher than normal cytokinin concentrations in the shoots, through increased production in the roots, may decrease permeability to water efflux and increase the danger of intracellular ice formation.

Although this line of reasoning remains very speculative, a decrease in hardiness resulting from high root temperatures and a subsequent hormone imbalance in the shoots, remains the most plausible explanation for the differences between the field and controlled environment results.

There is evidence that, like *Salix arctica*, the development of greater hardiness is, to a certain extent, through an internal regulation mechanism. As with arctic willow, individuals of *Saxifraga oppositifolia* were obtained from Truelove near the end of the 1979 growing season, returned to Edmonton, and placed in a +5°C environment with continuous light. Tissue tested on 16 August was hardy to below -20°C, and tolerant to below -32°C by 26 August. On 9 September all tissue was killed at -44°C and survived -40°C very poorly.

Since these low temperatures (-32°C) were not survived by either the 1978 field plants or the controlled environment plants, and yet the light and temperature

conditions were similar, it is apparent that an endogenously controlled increase in hardiness occurred. This possibility was considered in greater detail in the discussion of *Salix arctica* cold hardiness. The inability of *Saxifraga oppositifolia* to survive below -40°C when maintained at 5°C indicates that a further level of hardening must occur, probably through exposure to lower temperatures (see Weiser 1970 and Introduction). However, a natural increase in cold hardiness to near -40°C in the absence of frost is certainly sufficient protection against rapid temperature drops that might accompany the approaching arctic winter.

3. Field Water Relations

Diurnal variation in early season leaf water potential was absent in *Saxifraga oppositifolia* (Fig. 38). Mean values ranged between -0.76 MPa and -1.18 MPa, and none was significantly different at the 95% level. Later in the season (1 August) leaf water potential was generally lower (Fig. 38). At that time there was an indication of a drop in water potential near midday, although the difference was not statistically significant. In August, the highest mean values were found at 2300 and 0400 h (-1.04 and -0.94 MPa; respectively) and the lowest water potentials were near midday (-1.66 MPa).

Leaves of *Saxifraga oppositifolia* persist for two years before senescence (Svoboda 1974). Second year leaves were

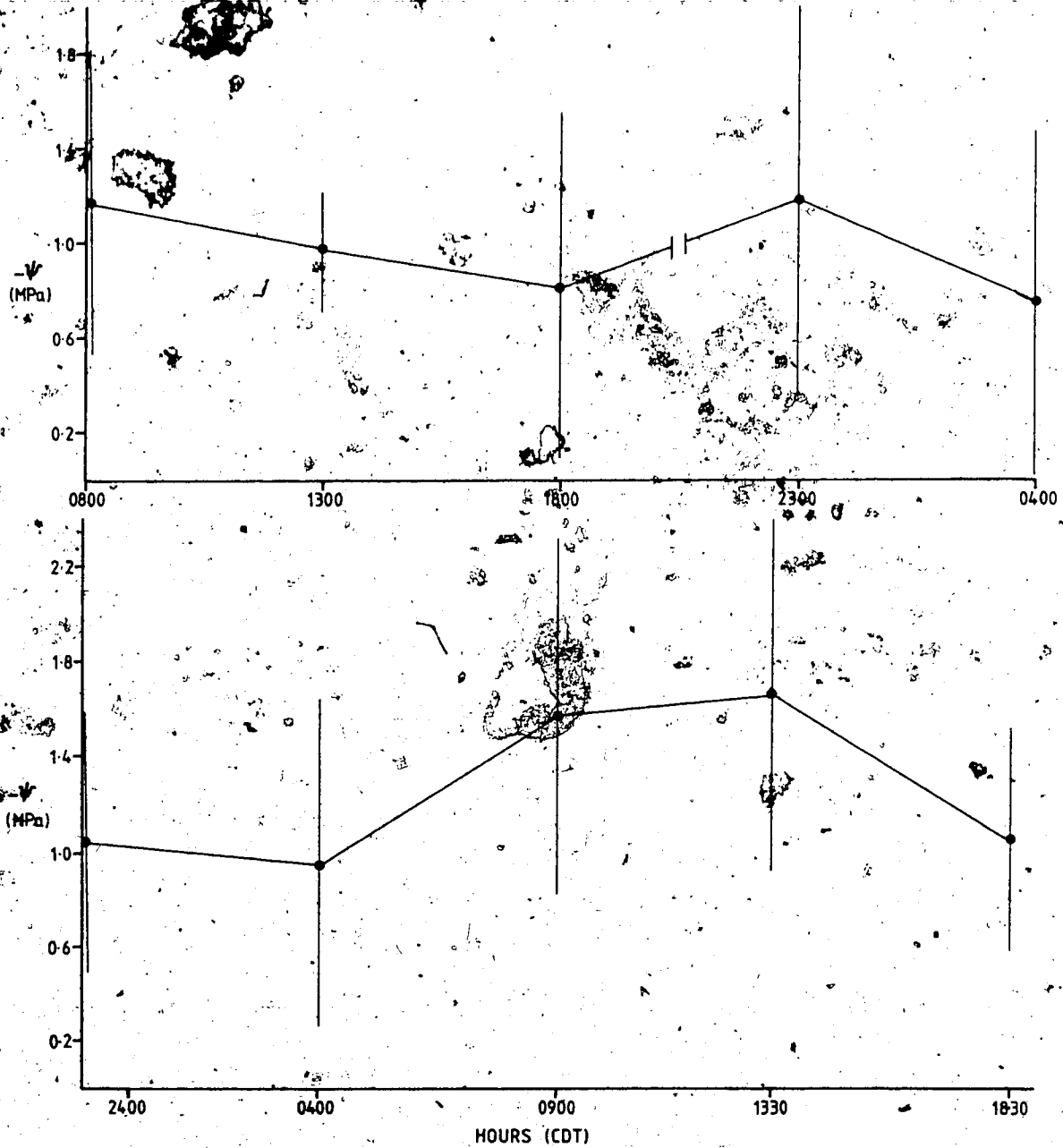

Fig. 38. Diurnal variation in leaf water potential of *Saxifraga oppositifolia* under field conditions. Upper figure shows results from 5 (left) and 7 (right) July. Lower figure is based on 15 August data. Bars show 95% confidence limits (n=4).

necessarily used in the early season sampling, since little or no new growth was yet present. The absence of pronounced diurnal variation in water potential in early July, under conditions of strong variation in light intensity and leaf temperature, suggests that soil moisture was high and internal resistance to water flow was low. A second possibility is that the stomata of second year leaves are relatively insensitive to variation in light intensity and vapor pressure gradients, which would result in little diurnal change in leaf water potential. A comparison of current and one-year old leaves of *Pinus sylvestris* showed older leaves to exhibit less of a leaf water deficit with increasing water stress (Sands and Rutter 1958). Other studies with conifers have found a pattern of increasing minimum leaf resistance with age in some species (Waggoner and Turner 1971 in Hinckley et al. 1978, Running 1976), which would tend to mitigate the effects that fluctuations in vapor pressure gradient would have on leaf water potential.

In early August, the slight drop in mean leaf water potential (ca. 0.6 MPa) at midday suggest that a reduction in soil moisture had occurred by then. The control plants were located at midslope, rather than near the slope base, and drier conditions likely prevailed at their location. Teeri (1972, 1973) reported diurnal fluctuations (about 0.6 MPa), similar to those found here, for beach ridge populations of *Saxifraga oppositifolia* from Truelove. He

found minimum leaf water potentials to occur in early afternoon, as was seen in this study.

Only the short day treatment appeared to affect the mean midday water potential of the plants (Fig. 39). With the exception of the post-chinook sample (4 August), the mean leaf water potential under short days always occurred between -1.85 MPa and -2.15 MPa. The implications of these results are discussed later together with the controlled environment results.

In contrast, none of the other treatments showed mean values in that range. The neutral density filter appeared to create an environment under which the plants varied little in water potential. Values ranged only between -1.19 MPa in mid-July to -1.45 MPa in mid-August (Fig. 39). The buffering effects that the cheesecloth may have had on the humidity and light environment under the ND domes were discussed earlier with respect to willow, and the same appears relevant to *Saxifraga oppositifolia*.

The -red and -blue treated plants fluctuated more widely (ca. 0.5 to 0.6 MPa), but revealed no differences between the seasonal patterns of leaf water potential that could be accounted for by anything but natural differences between plants and microsites. Both treatments began and ended the season with mean leaf water potentials within 0.1 MPa and had essentially identical mean values on two other occasions (Fig. 39). The control plants exhibited wider fluctuation in mean leaf water potential throughout the

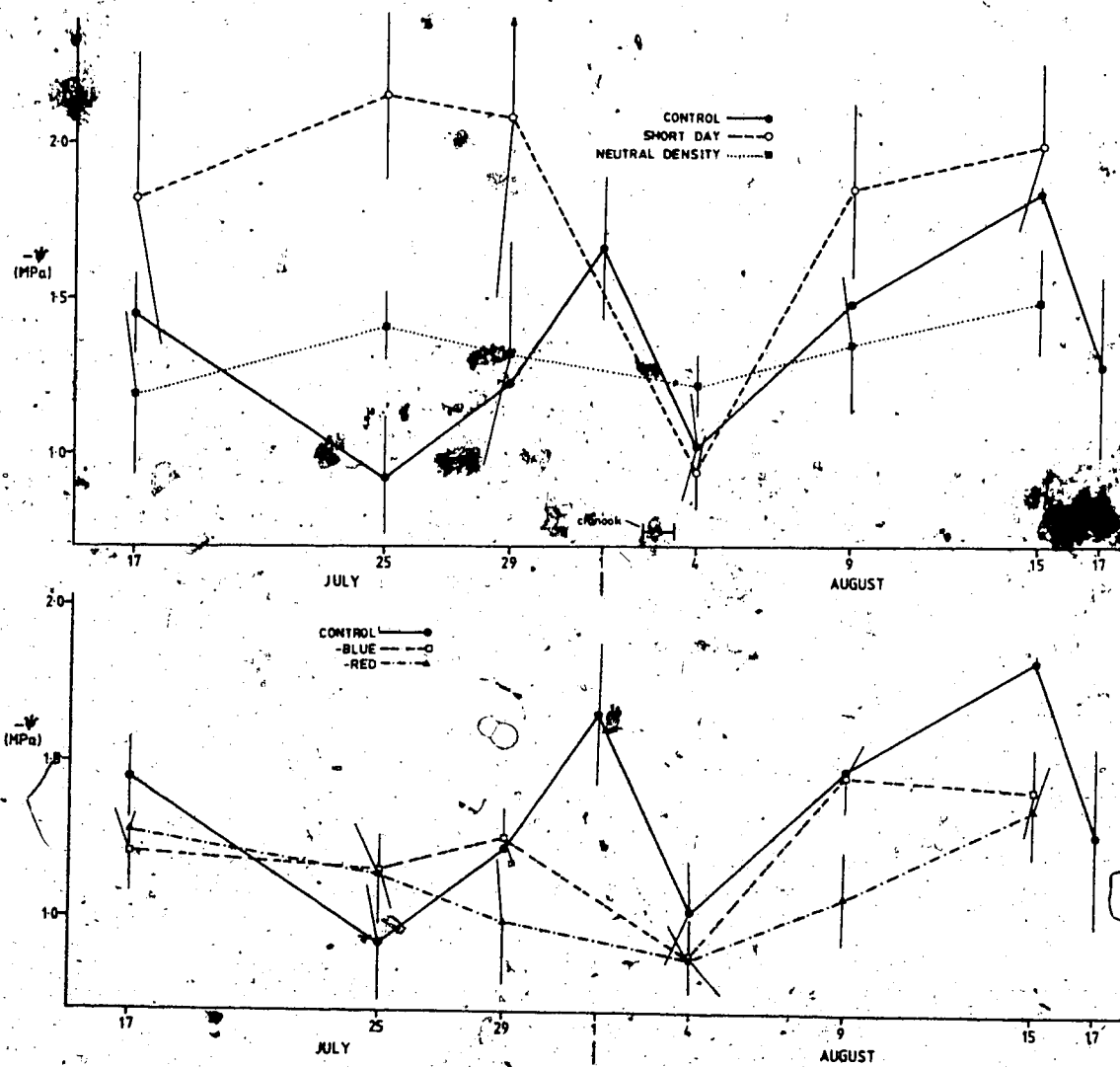

Fig. 39: Effects of field treatments on the total leaf water potential of *Saxifraga oppositifolia*. All tissue was collected at 1300 h CDT, except on 17 August (0800). Bars indicate standard error of the mean (n=1-4).

season than seen in most other treatments. The highest mean midday water potential (-0.92 MPa) occurred in late July, and the lowest was in mid-August (-1.84 MPa). It is only near the end of the season that the midday leaf water potential of the control plants may be considered very much different from the dome treatments. The 1 August value was part of the diurnal curve determination, and with no comparative samples from the other treatments at that time it cannot be known whether or not those plants also decreased in water potential. This instance illustrates that the assumption of linearity in the relationship between two points that is implied when straight lines are drawn is not necessarily valid.

The slightly lower end-of-season water potential (-1.82 MPa) in the control plants may be largely a reflection of the mid-slope position of these plants (i.e. drier soil), relative to the other treatments down slope. The higher earlier morning value found two days later (-1.28 MPa) suggests that a partial recharge of tissue could still occur this late in the season, indicating that soil moisture was not entirely depleted. Recent rains probably helped, and relative humidity was 94% at the time of sampling. Also, a sort of twilight occurred during the "night" at this time which would be conducive to stomatal closure and tissue rehydration.

The chinook of 2-3 August resulted in higher leaf water potentials in most treatments than at any other time of the

year (Fig. 39). At the 4 August sampling the plants still exhibited signs of the stomatal closure which must have occurred during the chinook. At 1300 h, approximately 17 hours after conditions returned to normal (i.e. 70% RH and 6°C), relatively high water potentials were evident. Teeri (1972) reported on the effects of a 46-h chinook in 1969 and found the leaf water potential of beach ridge plants of *Saxifraga oppositifolia* dropped to -1.7 MPa at the end of the wind, compared to -0.5 MPa prior to the stress. It is possible that the 17 h post-chinook period was adequate for recovery. A delay in the opening of stomata after tissue rehydration would explain the high water potentials. This was seen in tobacco and other species where stomata remained nearly closed for up to 48 h after the turgor of previously water stressed leaves had been re-established (Fischer et al. 1970, Fischer, 1970).

The leaf water potential of the short day plants was unusually high (-0.94 MPa) on 4 August relative to any other sampling date during the season (Fig. 39). It is possible that normal stomatal function had been disrupted by the short days, resulting in a reduced stomatal response to stress conditions (i.e. remaining open) and lower leaf water potentials. However, the prolonged period of low humidity (ca. 28 h) and high air temperatures (10°) may have been sufficient to induce closure and allow the tissue to hydrate.

A second possibility lies in an increase in the

internal resistance to water flow as a result of short days. Short days have been implicated in the increase in root resistance and reduced stem hydration in *Cornus stolonifera* (Parsons 1978, McKenzie et al. 1974b). The same treatment decreased relative water content and leaf water potential in *Ledum groenlandicum* (Wilkinson 1977). In this case, reduced midday water potential would regularly occur as a result of the inability of the plant to deliver water rapidly enough to replace transpirational loss. Prolonged closure of stomata during the chinook could have allowed sufficient rehydration to be still evident at the next midday sampling 17 h later.

4. Controlled Environment Water Relations

The bulk leaf water potential of the control plants did not significantly change throughout the 62 day sampling period (Fig. 40). After two days of above freezing temperatures, the mean leaf water potential was -0.95 MPa, and 60 days later the mean value was -0.97 MPa. During that time, mean water potentials ranged between -1.17 and -0.72 MPa..

The frozen tissue showed significantly lower total water potentials (-3.05 MPa) at the 95% level. This was as expected for cold hardy tissue in the frozen state, since cell dehydration accompanies the freezing of cold hardy plants (freeze dehydration) (Levitt 1972).

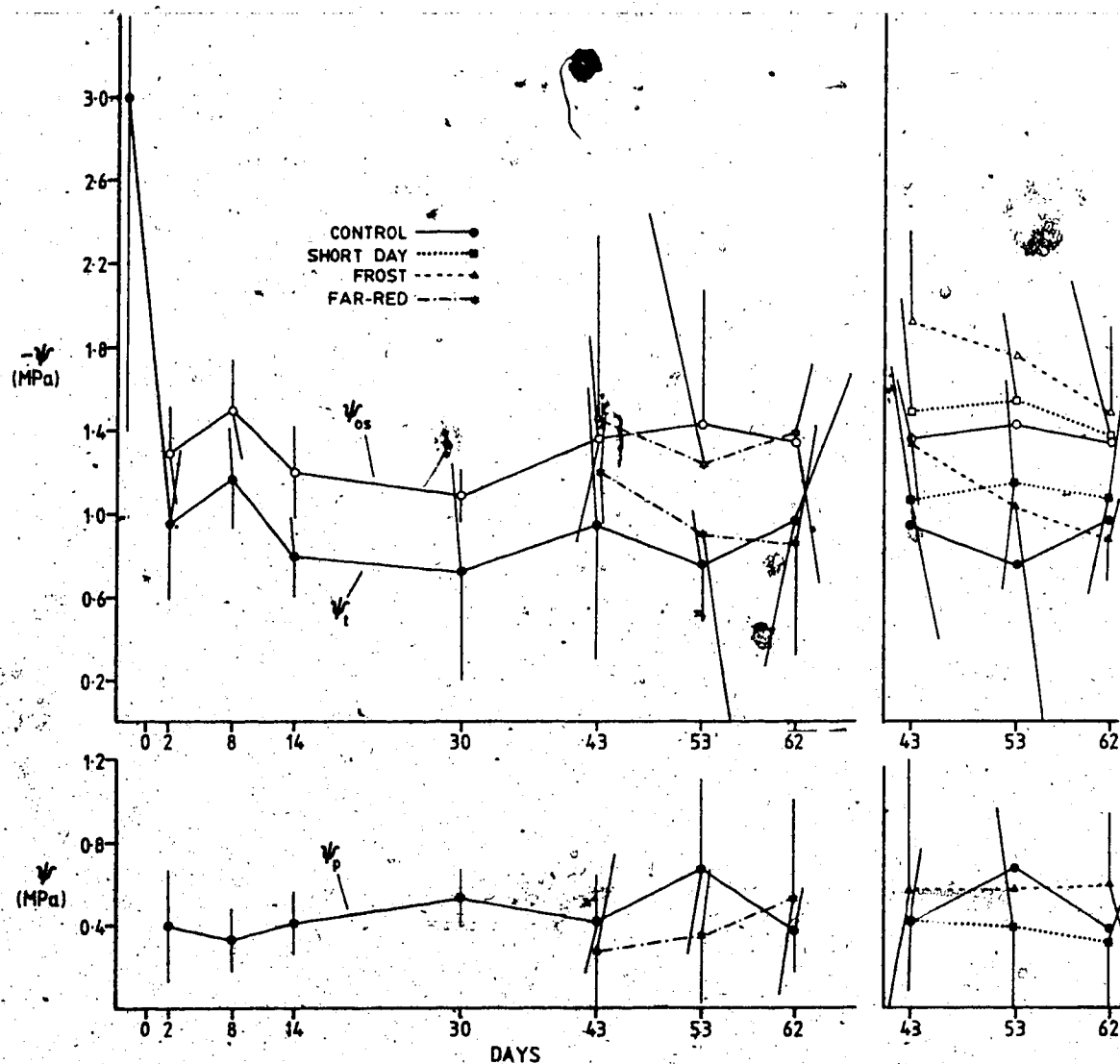

Fig. 40. Effects of controlled environment treatments on the leaf water potential of *Saxifraga oppositifolia*. Day 0 marks the beginning of above freezing temperatures. In the upper figure, closed symbols indicate total leaf water potential; open symbols show osmotic potential. Turgor is shown in lower figure. 95% confidence limits are given (n=2-4).

Osmotic potentials in controls remained insignificantly different from each other (Fig. 40). Mean values were between -1.09 and -1.50 MPa, with most data occurring between the -1.20 and -1.40 MPa range. Turgor remained relatively unchanged, as the plants began and ended the growing period with ca. 0.4 MPa of pressure. Mean values ranged between 0.33 and 0.68 MPa.

The far-red, frost and short day regimes did not significantly affect the mean leaf water potential of *Saxifraga oppositifolia* after 33 days of treatment (Fig. 40). Both the far-red and frost treated plants appeared, at first, to have slightly lower values than the controls, but by the end of the study all three sets of plants were within 0.1 MPa of each other. The short day plants remained near -1.10 MPa during the 19 day sampling period and was also within 0.1 MPa of the control at the end of the testing.

The osmotic potentials of the treatment plants often averaged lower than the control plants, but were not significantly different at the 95% level (Fig. 40). The mean osmotic potential of the frost treated plants increased from -1.91 MPa after 2 weeks of treatment to -1.47 MPa 19 days later. The short day plants changed little from the first to last sampling (-1.48 to -1.37 MPa), and the far-red treatment showed almost identical values. At the end of the study, the mean osmotic potentials were -1.47 , -1.39 , -1.37 and -1.34 MPa for the cold, far-red, short day and control treatments, respectively.

Turgor in all three treatments was similar to that found in the control plants (Fig. 40). The mean pressure potential of the cold treated plants remained near 0.6 MPa throughout the study. Short day plants also appeared unchanged as mean values ranged between 0.42 and 0.32 MPa. Plants under far-red treatment showed a mean pressure potential of 0.28 MPa at the first sampling and 0.53 MPa on the last day. All treatments were within 0.22 MPa of the control when the trials ended and no results were significantly different at the 95% level.

It is clear that the treatments did not affect the water relations of *Saxifraga oppositifolia* in a significant way. However, the low osmotic potential of -1.1 MPa seen in the frost treated plants after 14 days of treatment, while not statistically different, may have indicated that metabolic adjustment to the short periods of freezing was occurring. Siminovitch et al. (1975) suggested that the increase in unsaturated fatty acids often observed in herbaceous plants grown at low temperatures is simply a result of metabolic processes (required for hardening) occurring at low temperatures, and not a cause of increased hardness in itself. In a similar way, metabolic changes may have been induced by freezing temperatures in *Saxifraga oppositifolia* (not necessarily changes in fatty acids) which resulted in a temporary increase in leaf osmotic potential. No change in cold hardiness was noted at this time (Table 5), but, as noted above, the changes need not cause an

increase in cold tolerance. A return to "normal" osmotic concentrations may have occurred after adjustments to the colder environment were completed, and would explain the later convergence with results from the other treatments.

5. Synthesis

In comparison to the well-watered plants grown under controlled environments, the field plants showed lower mean water potentials. This was as expected and is supported by Teeri's (1972, 1973) work with the same species near the same site on Truelove. He often found the leaf water potential of beach ridge populations to be below -1.0 MPa, and stress to -2.5 and -3.5 MPa occurred during drought. Plants in controlled environment chambers were able to be maintained at water potentials above -1.0 MPa, which he considered to be nonstress conditions. Very similar results are seen from Figs. 39 and 40.

Teeri (1973) also noted that net photosynthesis continued to be positive to the mean leaf water potential of -2.5 MPa. Beach ridge populations were not used in the present study, but the response of the midslope plants which were used was probably more similar to Teeri's beach ridge plants than to the meadow and snowbank populations he also studied. Thus, it is likely that water was not limiting to the 1978 control and treatment plants with respect to photosynthesis, despite the often low water potentials.

The growth chamber results reinforce the contention that the field treatments (excluding short day plants) were ineffective in altering the water relations of *Saxifraga oppositifolia*. The relatively unchanging water potential in the plants throughout the sampling period suggests that with adequate soil moisture *Saxifraga oppositifolia* can maintain a high leaf water potential, despite the obvious phenological changes (e.g. leaf yellowing) which occurred near the end of the testing, under all treatments. Teeri (1972) reported high leaf water potentials (ca. -0.5 MPa) in early to mid-August 1969, and much lower values earlier in the year. His results suggest that soil moisture availability played the major role in determining leaf water potential, assuming no other stressful conditions prevailed (e.g. chinook).

The very low water potentials exhibited by the short day plants in the field were not seen during the growth chamber studies. In some cases, the mean differences between short day and control plants differed by 0.1 to 0.4 MPa. In the field, the short day treatment was begun 7 July, and 18 days later the difference between the control and SD plants was 1.28 MPa. The same period of treatment under a controlled environment produced a 0.2-0.3 MPa difference between the two plant sets. The low field values might be the result of position on the beach ridge slope. However, from Fig. 9 it is evident that while the short day plants were near a midslope position, the control plants were not

any closer to the slope base. It is not likely that soil moisture was different enough between the locations of the two sets of plants to account for the wide discrepancy in results. Short days may have directly affected plant response to water, possibly through changes in stomata and/or root resistance, to the extent that only under stress conditions would the effects become manifest. If stomatal resistance was decreased (and transpiration increased) under short day treatment, then significant water stress could occur at midday when leaf temperatures were high and soil moisture limiting. As noted above, the field plants were apparently under some degree of water stress at most times, since leaf water potentials were generally less than -1.0 MPa, and this was presumably due to limitations in soil moisture. In the controlled environment, the radiation load (and therefore the vapor pressure gradient) was low and soil moisture high. A similar decrease in stomatal resistance would not have resulted in the same degree of leaf water stress as in the field because the rate of water loss at the leaf would be lower and could be matched by replacement by the root, even if resistance was slightly higher.

Parsons (1978) reported a decrease in stomatal resistance and an increase in transpiration in SD treated *C. stolonifera* relative to long day controls. Also, root resistance increased in SD plants. The net result was lower leaf water potentials in the SD plants (ca. 0.1 MPa) throughout most of the study. Although in this study the

differences between short day and control plants grown under controlled conditions were not significantly different, the magnitude of the differences was comparable to that found by Parsons (1978). Loveys et al. (1974) found a similar photoperiodically induced increase in stomatal conductance of *Betula lutea*.

With the present evidence and support from previous workers it appears that the short day treatment may have induced a decrease in stomatal resistance and possibly increased root resistance.

IV. Summary and Conclusions

The relatively low osmotic potentials (-1.85 to -2.11 MPa) maintained by *Salix arctica* under a controlled environment, along with a certain degree of freeze dehydration tolerance, is probably responsible for the level of leaf cold hardiness seen during the season (LT 50 = $-8.6 \pm 0.9^{\circ}\text{C}$ (95% confidence interval)). Under the same conditions, turgor is low during leaf expansion (ca. 0.3 MPa), but increases in mature leaves (1.10 to 1.20 MPa). Total leaf water potential is greater than -1.0 MPa when moisture is not limiting, and implies that the field plants were under some degree of stress throughout most of the season. In the field, leaf water potential is generally higher than the assumed threshold potential of -1.40 MPa, indicating that midday water stress was not excessive. Controlled environment studies showed a maintenance of high leaf water potential into the early stages of whole plant leaf senescence, and the results from the short day field studies suggest that an individual leaf retains a favorable water status until its final stages of senescence and abscission.

Relative to willow, *Saxifraga oppositifolia* maintained low turgor (between 0.3 and 0.5 MPa) and high osmotic potential (-1.10 to -1.50 MPa) under controlled environment conditions throughout the growing period. Total leaf water potential was very similar in the two species, generally occurring between -0.7 and -1.0 MPa. While well watered,

there was no clear evidence of decreased leaf water potential in *Saxifraga oppositifolia* when cold hardiness increased. Under short days, the leaf water potential of controlled environment plants remained unchanged throughout the study, although an increase in hardiness occurred near the end. The water potential of the control plants was only slightly higher (0.1 MPa). The much lower water potentials of the short day field treatments may have been a combination of short days (increased root resistance and/or stomatal opening) and water stress; the latter factor being absent in the growth chamber studies. The role of short days in the induction of decreased water potential in *Saxifraga oppositifolia* remains uncertain.

There were no clear indications that *Salix arctica* and *Saxifraga oppositifolia* initiate cold acclimation or dormancy through the perception of seasonal changes in the radiation environment on Truelove Lowland. This was so despite evidence (model predictions supported by data) which suggested that seasonal shifts in zeta can act in such a role. The 3.5°C difference in stem hardiness between *Salix arctica* grown in a controlled environment (-13.5°C) and the field controls in mid-August (-17°C) may have resulted through a triggering of the first acclimation stage by a low zeta occurring a few weeks earlier, but the difference is too small to be sure of its significance.

Short days were found to be effective in the induction of early dormancy (as indicated by premature leaf

senescence) and stem and shoot cold hardiness in *Salix arctica* and *Saxifraga oppositifolia*. Willow showed an increase in stem hardiness of at least 5° to 6°C (-10°C to <-15°C) under short days and when the inductive darkness of short days was replaced by far-red light. There was no effect of short days on leaf cold hardiness in the field, except possibly indirectly through the hastening of senescence. The mean seasonal leaf cold hardiness in the field was $-8.6 \pm .9^\circ\text{C}$ (95% confidence interval). Controlled environment studies showed a leaf hardiness value of -7°C .

Saxifraga oppositifolia exhibited an increased shoot hardiness of at least 8 to 10°C only under short days. The absence of induction under a far-red night may be due to a requirement for a longer treatment period to obtain the same response as with short days. In the field, shoots were hardy to between -15° and -18.6°C , while controlled environment studies showed hardiness between -9° and -10°C . The discrepancy may have been due to higher root temperatures in the growth chamber material, resulting in a hormonal imbalance.

The short day results in both species point to the presence of a phytochrome-mediated system of triggering cold acclimation, identical to that found for temperate species (see Weiser 1970). However, there is no opportunity for this system to come into play in the High Arctic and it apparently remains a relict within the two species, inherited from low latitude ancestors where it presumably

was (and possibly still is) adaptive.

In both species increased hardiness and dormancy occurred under field or simulated field conditions with no apparent environmental change. *Salix arctica*, under regularly cycling temperatures (10°C/3°C), showed a natural increase in stem hardiness of at least 7° to 10°C after growing for 58 days. Under controlled environment conditions (continuous light and +5°C), recently transplanted *Salix arctica* attained a stem cold hardiness to below -44°C and *Saxifraga oppositifolia* survived to between -32° and -40°C. These high levels of cold tolerance were observed at the time (September) when field plants were regularly experiencing below freezing temperatures, and increased stem hardiness would be necessary. An endogenously controlled increase in cold hardiness is implicated from these results. When fully hardened, *Salix arctica* survived immersion in liquid nitrogen (-196°C). Tropical willows have survived -50° to -70°C when properly hardened, and the present results lend support to the contention that willows are genetically preadapted to withstand very low temperatures (Sakai 1970). Previous studies (Kainmüller 1975) have shown *Saxifraga oppositifolia* to have the same ability to survive extremely low temperatures (-196°C).

Growth cessation and dormancy are also under endogenous control. In *Salix arctica*, the control plants twice initiated senescence under conditions normally conducive to growth and dormancy during 10 months of continuous light and

warm temperatures. Similarly, *Saxifraga oppositifolia* exhibited senescence of second year leaves under controlled environment conditions, independent of light and temperature changes. With *Salix arctica* in particular, the endogenously controlled hardiness increase appears to be correlated with leaf senescence and the process of becoming dormant, though cause and effect were not shown.

The low temperatures normally present during the arctic summer may be the factor responsible for the marked increase in hardiness in *Salix arctica* and *Saxifraga oppositifolia* at the end of the season. Endogenous changes in hormone balance (presumably ABA, GA and cytokinins) may create a readiness-to-harden condition coincident with leaf senescence and dormancy in which the plant is responsive to low temperatures (ca. 5°C) as a stimulus for the induction of cold hardiness. Earlier in the season the same temperatures would be ineffective. Perception of short days is only useful as a warning of cold temperatures ahead. If cold temperatures precede short days, as in the Arctic, the usefulness of this cue is gone and temperature is left as the sole external factor involved in the development of cold acclimation.

Table 6 summarizes the findings of this work. The results support the above scheme as a modification of the standard two-stage acclimation model (Weiser 1970) to a one-stage process involving decreasing temperature.

Table 6. Summary of the results of this study in relation to the seasonal pattern of cold acclimation in *Salix arctica* and *Salix fraga oppositifolia*.

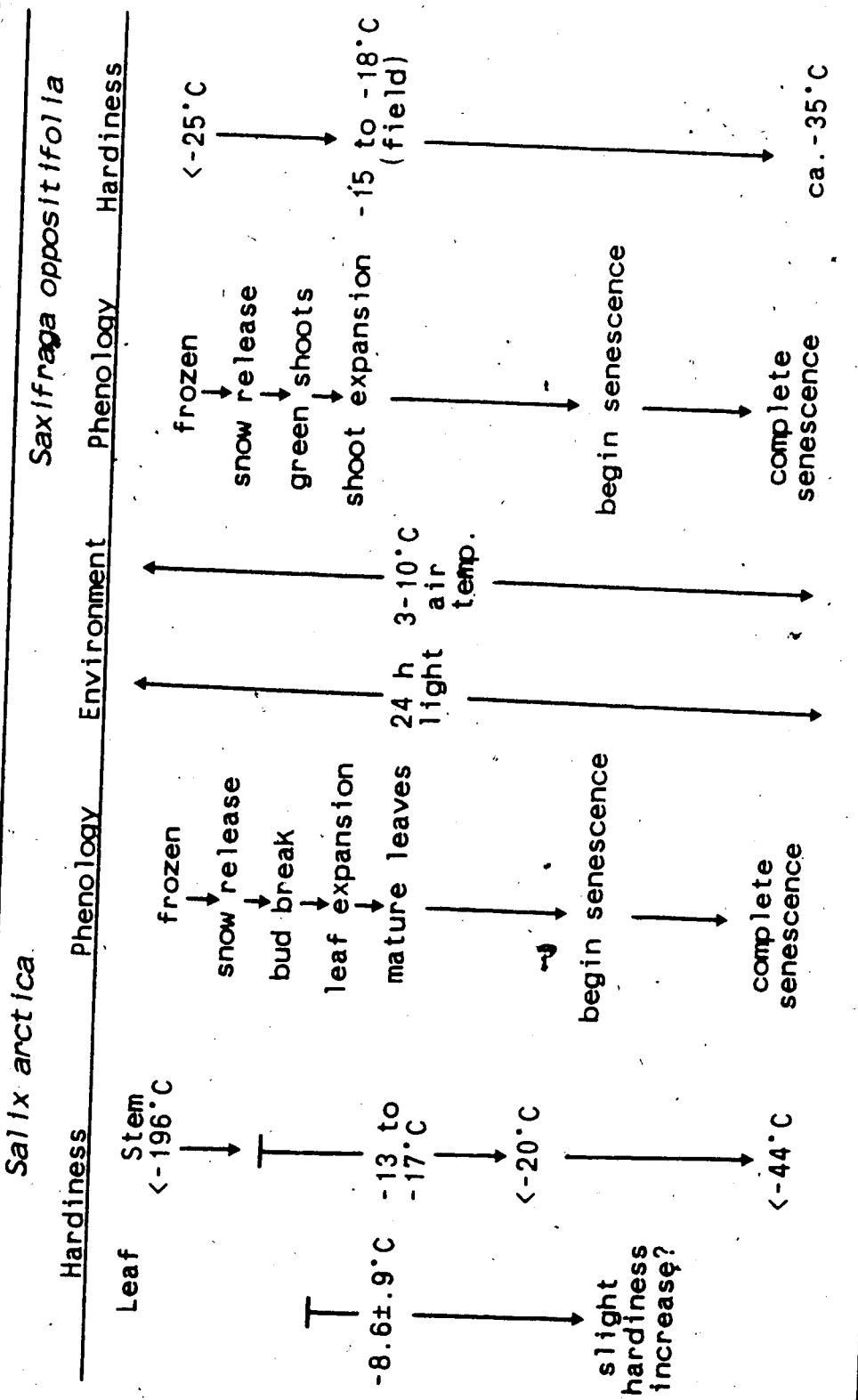

V. Literature Cited

- Addison, P.A. 1973. Studies on evapotranspiration and energy budgets in the High Arctic: a comparison of hydric and xeric microenvironments on Devon Island, N.W.T. M.Sc. thesis, Laurentian University, Sudbury.
- Addison, P.A. 1977a. Autecological studies of *Luzula confusa*: A plant response to the High Arctic environment on King Christian Island, N.W.T. Ph.D. thesis, University of Alberta.
- Addison, P.A. 1977b. Studies on evapotranspiration and energy budgets on Truelove Lowland. pp. 281-300. In: Truelove Lowland, Devon Island, Canada: A High Arctic Ecosystem. L.C. Bliss (ed.) University of Alberta Press, Edmonton.
- Addison, P.A. and L.C. Bliss. 1980. Summer climate, microclimate and energy budget of a polar semidesert on King Christian Island, N.W.T., Canada. *Arctic and Alpine Res.* 12:161-170.
- Alden, J. and R.K. Hermann. 1971. Aspects of the cold hardiness mechanism in plants. *Bot. Rev.* 37:37-142.
- Alvim, R. 1973. Studies on endogenous hormones in relation to dormancy in woody plants. Ph.D. dissertation. University of Wales, U.K.
- Alvim, R., P.F. Saunders and R.S. Barros. 1979. Abscisic acid and the photoperiod induction of dormancy in *Salix viminalis*. *Plant Physiol.* 63:774-777.
- Angström, A. 1961. Techniques of determining turbidity of the atmosphere. *Tellus* 13:214-223.
- Archer, M.D. 1978. The fraction of solar energy available for direct conversion process. *Solar Energy* 20:167-169.
- Arnulf, A. and J. Bricard. 1957. Transmission by haze and fog in the spectral region 0.35 to 10 microns. *J. Opt.*

- Soc. Amer. 47:491-498.
- Barr, W. 1971. Postglacial isostatic movement in northeastern Devon Island: a reappraisal. *Arctic* 24:249-268.
- Batanouny, K.H. 1974. Eco-physiological studies on desert plants IX. Types of transpiration curves of *Zilla spinosa* (Prantl) under natural conditions. *Flora* 163:1-6.
- Beevers, L. 1976. Senescence. pp. 771-794. In: *Plant Biochemistry*, 3rd ed. J. Bonner and J.E. Varner (eds.). Academic Press, New York.
- Biebl, R. 1967. Kurztageinflüsse auf arktische Pflanzen während der arktischen Langetage. *Planta* 75:77-84.
- Biebl, R. 1968. Über Wärmehaushalt und Temperaturresistenz arktischer Pflanzen in Westgrönland. *Flora* 157:327-354.
- Billings, W.D., P.J. Godfrey, B.F. Chabot and D.P. Bourque. 1971. Metabolic acclimation to temperature in arctic and alpine ecotypes of *Oxyria digyna*. *Arctic and Alpine Res.* 3:277-289.
- Bliss, L.C. 1966. Plant productivity in alpine microenvironments on Mt. Washington, New Hampshire. *Ecol. Monogr.* 36:125-155.
- Bliss, L.C. 1977. Introduction. pp. 1-11. In: Truelove Lowland, Devon Island, Canada: A High Arctic Ecosystem. L.C. Bliss (ed.) University of Alberta Press, Edmonton.
- Boyer, J.S. 1968. Relationship of water potential to growth of leaves. *Plant Physiol.* 43:1056-1062.
- Boyer, J.S. 1970. Leaf enlargement and metabolic rates in corn, soybean and sunflower at various leaf water potentials. *Plant Physiol.* 46:233-235.
- Brown, J.A.M. and W.H. Klein. 1971. Photomorphogenesis in *Arabidopsis thaliana* L. Heynh. Threshold intensities and

- blue-far-red threshold intensities in floral induction. *Plant Physiol.* 47:393-399.
- Bünning, E. 1973. *The physiological clock*. 3rd ed. Academic Press, New York.
- Burke, M.J., L.V. Gusta, H.A. Quamme, C.J. Weiser and P.H. Li. 1976. Freezing and injury in plants. *Ann. Rev. Plant Physiol.* 27:507-528.
- Caldwell, M.M. 1970. Plant gas exchange at high wind speeds. *Plant. Physiol.* 46:535-537.
- Chen, P.M. and P.H. Li. 1977. Induction of frost hardiness in stem cortical tissues of *Cornus stolonifera* Michx. by water stress. II. Biochemical changes. *Plant Physiol.* 59:240-243.
- Chen, H.H. and P.H. Li. 1978. Interactions of low temperature, water stress and short days in the induction of stem frost hardiness in red osier dogwood. *Plant Physiol.* 62:833-835.
- Chen, P., P.H. Li and M.J. Burke. 1977. Induction of frost hardiness in stem cortical tissues of *Cornus stolonifera* Michx. by water stress. I. Unfrozen water in cortical tissues and water status in plants and soil. *Plant Physiol.* 59:236-239.
- Chen P., P.H. Li, C.J. Weiser. 1975. Induction of frost hardiness in red osier dogwood stems by water stress. *Hortscience* 10:372-374.
- Cleland, R. 1967. A dual role of turgor pressure in auxin-induced cell elongation in *Avena* coleoptiles. *Planta* 77:182-191
- Collins, J.C. 1974. Hormonal control of ion and water transport in the excised maize root. pp. 441-443. *In: Membrane Transport in Plants*. U. Zimmerman and J. Dainty (eds.). Springer-Verlag, New York.
- Collins, J.C. and A.P. Kerrigan. 1974. The effect of kinetin and abscisic acid on water and ion transport in isolated

- maize roots. *New Phytol.* 73:309-314.
- Conover, W.J. 1971. *Practical nonparametric statistics*. Wiley, New York.
- Corbet, P.S. 1972. The microclimate of arctic plants and animals, on land and in fresh water. *Acta Arctica* 18:1-43.
- Cooper, J.P. 1964. Climatic variation in forage grasses. I. Leaf development in climatic races of *Lolium* and *Dactylis*. *J. Appl. Ecol.* 1:45-61.
- Courtin, G.M. and C.L. Labine. 1977. Microclimatological studies on Truelove Lowland. pp. 73-106. *In: Truelove Lowland, Devon Island, Canada: A High Arctic Ecosystem*. L.C. Bliss (ed.) University of Alberta Press, Edmonton.
- Cumming, B.G. 1969. Photoperiodism and rhythmic flower induction: complete substitution of inductive darkness by light. *Can. J. Bot.* 47:1241-1250.
- Davis, S.D., C.H.M. vanBavel and K.J. McCree. 1977. Effect of leaf ageing upon stomatal resistance in bean plants. *Crop Sci.* 17:640-645.
- Dennis, J.G. and P.L. Johnson. 1970. Shoot and rhizome-root standing crops of tundra vegetation at Barrow, Alaska. *Arctic and Alpine Res.* 2:253-266.
- Dennison, D.S. 1979. Phototropism. pp. 506-566. *In: Encyclopedia of Plant Physiology, New Series, vol. 7. Physiology of Movements*. W. Haupt and M.E. Feinlab (eds.). Springer-Verlag, New York.
- Dixon, H.H. 1914. *Transpiration and ascent of sap in plants*. Macmillan and Co., London.
- Dixon, W.J. and F.J. Massey, jr. 1969. *Introduction to statistical analysis*. 3rd ed. McGraw-Hill Co., New York.
- Downs, R.J. and H.A. Borthwick. 1956. Effects of photoperiod on growth of trees. *Bot. Gaz.* 117:310-326.

- Durzan, C.J. 1968. Nitrogen metabolism of *Picea glauca*. I. Seasonal changes of free amino acids in buds, shoot apices, and leaves and the metabolism of uniformly labelled ^{14}C -L-arginine by buds during the onset of dormancy. *Can. J. Bot.* 46:909-919.
- Eagles, C.F. 1967. Variation in the soluble carbohydrate content of climatic races of *Dactylis glomerata* (cocksfoot) at different temperatures. *Ann. Bot.* 31:645-651.
- Ehleringer, J.R. and P.C. Miller. 1975. Water relations of selected plant species in the alpine tundra, Colorado. *Ecology* 56:370-380.
- Fischer, R.A. 1970. After-effect of water stress on stomatal opening potential. II. Possible causes. *J. Exp. Bot.* 21:386-404.
- Fischer, R.A., T.C. Hsiao and R.M. Hagan. 1970. After-effect of water stress on stomatal opening. I. Techniques and magnitudes. *J. Exp. Bot.* 21:371-385.
- Fischer, W.H. 1967. Some atmospheric turbidity measurements in Antarctica. *J. Appl. Met.* 6:958-959.
- Frankland, B. 1972. Biosynthesis and dark transformations of phytochrome. pp. 195-225. In: *Phytochrome*. K. Mitrakos and W. Shropshire Jr. (eds.). Academic Press, New York.
- Fry, K.E. 1965. A study of transpiration and photosynthesis in relation to stomatal resistance and internal water potential in Douglas fir. Ph.D. thesis, University of Washington, Seattle.
- Fuchigami, L.H., D.R. Evert and C.J. Weiser. 1971a. A translocatable cold hardiness promoter. *Plant Physiol.* 47:164-167.
- Fuchigami, L.H., C.J. Weiser, D.R. Evert. 1971b. Induction of cold acclimation in *Cornus stolonifera* Michx. *Plant Physiol.* 47:98-103.
- Gates, D.M. 1966. Spectral distribution of solar radiation

at the earth's surface. *Science* 151:523-529.

Gates, D.M. and C.C. Shaw. 1960. Infrared transmission of clouds. *J. Opt. Soc. Amer.* 50:876-882.

Gee, G.W. and C.A. Federer. 1972. Stomatal resistance during senescence of hardwood leaves. *Water. Resour. Res.* 8:1456-1460.

George, M.F., M.J. Burke, H.M. Pellet, and A.G. Johnson. 1974. Low temperature exotherms and woody plant distribution. *Hortscience* 9:519-522.

Goldsmith, M.H.M. 1977. The polar transport of auxin. *Ann. Rev. Plant Physiol.* 28:439-478.

Gusta, L.V. and C.J. Weiser. 1972. Nucleic acid and protein changes in relation to cold acclimation and freezing injury of Korean boxwood leaves. *Plant Physiol.* 49:91-96.

Hall, A.E., E.-D. Schulze and O.L. Lange. 1976. Current perspectives of steady-state stomatal response to environment, pp. 169-188. *In: Water and Plant Life.* O.L. Lange, L. Rappen, E.-D. Schulze (eds.). *Ecological Studies.* vol. 19. Springer-Verlag, New York.

Harrison, L.C., C.J. Weiser and M.J. Burke. 1978a. Environmental and seasonal factors affecting the frost-induced stage of cold acclimation in *Cornus stolonifera* Michx. *Plant Physiol.* 62:894-898.

Harrison, L.C., C.J. Weiser and M.J. Burke. 1978b. Freezing of water in red-osier dogwood stems in relation to cold hardiness. *Plant Physiol.* 62:899-901.

Hartgerink, A.P. 1975. controlled environment studies on net assimilation and water relations of arctic *Dryas integrifolia*. M.Sc. thesis, University of Alberta, Edmonton.

Hedberg, O. 1964. Features of afroalpine plant ecology. *Acta. Phytogeogr. Suec.* 49:1-144.

- Heber, U. and K.A. Santarius. 1973. Cell death by cold and heat and resistance to extreme temperatures. Mechanisms of hardening and dehardening. pp. 232-263. *In: Temperature and Life*. H. Precht, J. Christophersen, H. Hensel and W. Larcher (eds.). Springer-Verlag, New York.
- Heber, U. and K.A. Santarius. 1976. Water stress during freezing. pp. 253-267. *In: Water and Plant Life*. O.L. Lange, L. Kappen and E.-D. Schulze (eds.). Springer-Verlag, New York.
- Hinckley, T.M., J.P. Lassoie and S.W. Running. 1978. Temporal and spatial variations in the water status of forest trees. *For. Sci. Monogr.* 20:1-72.
- Hoagland, D.R. and D.I. Arnon. 1938. The water-culture method for growing plants without soil. University of California Agricultural Experimental Station Circular #347.
- Hofstra, G. and J.D. Hesketh. 1969. The effect of temperature on stomatal aperture in different species. *Can. J. Bot.* 47:1307-1310.
- Holmes, M.G. 1975. Studies of the ecological significance of phytochrome. Ph.D. thesis, University of Nottingham.
- Holmes, M.G. and H.A. McCartney. 1976. Spectral energy distribution in the natural environment and its implications for phytochrome function. pp. 467-476. *In: Light and Plant Development*. H. Smith (ed.). Butterworths, Toronto.
- Holmes, M.G. and H. Smith. 1975. The function of phytochrome in plants growing in the natural environment. *Nature* 254:512-514.
- Holmes, M.G. and H. Smith. 1977a. The function of phytochrome in the natural environment - I. Characterization of daylight for studies in photomorphogenesis and photoperiodism. *Photochem. and Photobiol.* 25:533-538.
- Holmes, M.G. and H. Smith. 1977b. The function of phytochrome in the natural environment - IV. Light

- quality and plant development. Photochem. and Photobiol. 25:551-557.
- Holmes, M.G. and E. Wagner 1980. A re-evaluation of phytochrome involvement in time measurement in plants. J. Theor. Biol. 83:255-265.
- Howell, G.S. and C.J. Weiser. 1970. The environmental control of cold acclimation in apple. Plant Physiol. 45:390-394.
- Hsiao, T.C. 1973. Plant responses to water stress. Ann. Rev. Plant Physiol. 24:519-570.
- Hurst, C., T.C. Hall and C.J. Weiser. 1967. Reception of the light stimulus for cold acclimation in *Cornus stolonifera* Michx. Hortscience 2:164-166.
- Irving, R.M. 1969. Characterization and role of an endogenous inhibitor in the induction of cold hardiness on *Acer negundo*. Plant Physiol. 44:801-805.
- Irving, R.M. and F.O. Lanphear. 1967a. Environmental control of cold hardiness in woody plants. Plant Physiol. 42:1191-1196.
- Irving, R.M. and F.O. Lanphear. 1967b. The long day leaf as a source of cold hardiness inhibitors. Plant Physiol. 42:1384-1388.
- Irving, R.M. and F.O. Lanphear. 1968. Regulation of cold hardiness in *Acer negundo*. Plant Physiol. 43:9-13.
- Johnson, T.B. and F.B. Salisbury. 1967. Ratio of blue to red light: a brief increase following sunset. Science 155:1663-1665.
- Jordan, W.R., K.W. Brown, and J.C. Thomas. 1975. Leaf age as a determinant in stomatal control of water loss from cotton during water stress. Plant Physiol. 56:595-599.
- Juntilla, O. 1976. Apical growth cessation and shoot tip abscission in *Salix*. Physiol. Plant. 38:278-286.

- Juntilla, O. 1980a. Effect of photoperiod and temperature on apical growth cessation in two ecotypes of *Salix* and *Betula*. *Physiol. Plant.* 48:347-352.
- Juntilla, O. 1980b. Flower bud differentiation in *Salix pentandra* as affected by photoperiod, temperature and growth regulators. *Physiol. Plant.* 49:127-134.
- Kainmüller, C. 1975. Temperaturresistenz von Hochgebirgspflanzen. *Sitz. Ber. Oesterr. Akad. Wiss. math. nat. Kl. Nr. 7.* pp. 67-75.
- Kassam, A.H. and J.F. Elston. 1974. Seasonal changes in the status of water and tissue characteristics of leaves of *Vicia faba* L. *Ann Bot.* 38:419-429.
- Kerr, J.P., G.W. Thurtell and C.B. Tanner. 1967. An integrating pyranometer for climatological observer stations and mesoscale networks. *J. Appl. Met.* 6:688-694.
- Knipling, E.B. 1967. Effects of leaf aging on water deficit-water potential relationships of dogwood leaves growing in two environments. *Physiol. Plant.* 20:65-72.
- Krasavtsev, O.A. 1969. Effect of prolonged frost on woody plants. *Sov. Plant. Physiol.* 16:188-194.
- Krinov, E.L. 1953. Spectral reflective properties of natural formations. *National Res. Council Canada Tech. Trans.* 439. G. Belkov, translator. *Laboratoriia Aerometodov, Akad. Nauk SSR. Moscow, 1947.*
- Kuhn, M. 1972. Spektrale Transparenz der antarktischen Atmosphäre, Teil II: Messergebnisse und Analyse. *Arch. Met. Geophys. Bioklm.* 20:299-344.
- Labine, C.L. 1974. Measurement and computer simulation of microclimate differences between a polar desert plateau and a nearly coastal lowland. M.Sc. thesis, University of Guelph, Guelph.
- Landsberg, P.T. and J.R. Mallinson. 1975. 11th I.E.E.E. Photovoltaic Specialist Conference.

- Larcher, W. 1975. *Physiological Plant Ecology*. M.A. Bieder-Thorson, translator. Springer-Verlag, New York.
- Larcher, W., U. Heber and K.A. Santarius. 1973. Limiting temperatures for life functions. pp. 195-263. *In: Temperature and Life*. H. Precht, J. Christophersen, H. Hensel and W. Larcher (eds.). Springer-Verlag, New York.
- Leckner, B. 1978. The spectral distribution of solar radiation at the earth's surface - elements of a model. *Solar. Energ.* 20:147-150.
- Levitt, J. 1956. *The hardiness of plants*. Academic Press, New York.
- Levitt, J. 1957. The role of cell sap concentration in frost hardiness. *Plant Physiol.* 32:237-239.
- Levitt, J. 1959. Effects of artificial increases in sugar content on frost hardiness. *Plant. Physiol.* 34:401-402.
- Levitt, J. 1972. *Responses of Plants to Environmental Stresses*. Academic Press, New York.
- Lewis, M.C. and T.V. Callaghan. 1976. Tundra. pp. 399-433. *In: Vegetation and the Atmosphere*. vol. 2. Case Studies. J.L. Monteith (ed.). Academic Press, New York.
- Li, P.H. and C.J. Weiser. 1974. Increasing cold resistance of stem sections of *Cornus stolonifera* by artificial dehydration. *Cryobiology* 8:108-111.
- Li, P.H., C.J. Weiser and R. van Huystee. 1965. Changes in metabolites of red osier dogwood during cold acclimation. *Proc. Amer. Soc. Hort. Sci.* 86:723-730.
- List, R.J. 1949. *Smithsonian Meteorological Tables*. 6th rev. ed. Smithsonian Institution Press, City of Washington.
- Loferski, J.J. 1956. Theoretical considerations governing the choice of the optimum semiconductor for photovoltaic solar energy conversion. *J. Appl. Phys.* 27:777-784.

- Loveys, B.R., A.C. Leopold and P.E. Kriedmann. 1974. Abscisic acid metabolism and stomatal physiology in *Betula lutea* following alteration in photoperiod. *Ann. Bot.* 38:85-92.
- Mayo, J. 1974. A thermocouple psychrometer for field and laboratory use. *Can. J. Plant Sci.* 54:597-598.
- Mayo, J., A.P. Hartgerink, D.G. Despain, R.G. Thompson, E.M. van Zinderen Bakker, Jr. and S.D. Nelson. 1977. Gas exchange studies of *Carex* and *Dryas*, Truelove Lowland. pp. 265-280. In: Truelove Lowland, Devon Island, Canada: A High Arctic Ecosystem. L.C. Bliss (ed.) University of Alberta Press, Edmonton.
- Mazur, P. 1969. Freezing injury in plants. *Ann. Rev. Plant Physiol.* 20:419-448.
- McCartney, H.A. and M.H. Unsworth. 1978. Spectral distribution of solar radiation. I: direct radiation. *Quart. J. Roy. Met. Soc.* 104:699-718.
- McClatchey, R.A., R.W. Fenn, J.E.A. Selby, F.E. Volz and J.S. Garing. 1972. Optical properties of the atmosphere. 3rd ed. Air Force Cambridge Research Laboratories. AFCRL-72-0497.
- McCown, B.H. 1973. The influence of soil temperature on plant growth and survival in Alaska. *Proc. Symp. Oil Resource Develop. Impact North. Plant Comm.* B.H. McCown and D.R. Simpson (eds.). University of Alaska.
- McKenzie, J.S. and C.J. Weiser. 1975. Technique to inoculate woody plant stem sections with ice during artificial freezing. *Can. J. Plant Sci.* 55:651-653.
- McKenzie, J.S., C.J. Weiser and M.J. Burke. 1974a. Effects of red and far-red light on the initiation of cold acclimation in *Cornus stolonifera* Michx. *Plant Physiol.* 53:783-789.
- McKenzie, J.S., C.J. Weiser and P.H. Li. 1974b. Changes in water relations of *Cornus stolonifera* during cold acclimation. *J. Amer. Soc. Hort. Sci.* 99:223-228.

- McKenzie, J.S., C.J. Weiser, E.J. Stadelmann and M.J. Burke. 1974c. Water permeability and cold hardiness of cortex cells in *Cornus stolonifera* Michx. - A preliminary report. *Plant Physiol.* 54:173-176.
- McNaughton, S.J., R.S. Campbell, R.A. Freyer, J.E. Mylroie and K.D. Rodland. 1974. Photosynthetic properties and root chilling responses of altitudinal ecotypes of *Typha latifolia* L. *Ecology* 55:168-172.
- Meidner, H. and T.A. Mansfield. 1968. *Physiology of Stomata*. McGraw-Hill, New York.
- Meyer, R.F. and J.S. Boyer. 1972. Sensitivity of cell division and cell elongation to low water potentials in soybean hypocotyls. *Planta* 108:77-87.
- Middleton, W.E.K. 1954. The color of the overcast sky. *J. Opt. Soc. Amer.* 44:793-798.
- Miller, P.C., W.A. Stoner and J.R. Ehleringer. 1978. Some aspects of water relations of arctic and alpine regions. pp. 343-357. *In: Vegetation and Production Ecology of an Alaskan Arctic Tundra*. L.L. Tieszen (ed.). Springer-Verlag, New York.
- Mohr, H. 1972. *Lectures on Photomorphogenesis*. Springer-Verlag, New York.
- Mooney, H.A. and W.D. Billings. 1961. Comparative physiological ecology of arctic and alpine populations of *Oxyria digyna*. *Ecol. Monogr.* 31:1-29.
- Morgan, D.C. and H. Smith. 1976. Linear relationship between phytochrome photoequilibrium and growth in plants under simulated natural radiation. *Nature* 262:210-211.
- Morgan, D.C. and H. Smith. 1978. The relationship between phytochrome photoequilibrium and development in light grown *Chenopodium album* *Planta* 142:187-193.
- Morgan, D.C. and H. Smith. 1979. A systematic relationship between phytochrome-controlled development and species habitat for plants grown in simulated natural radiation.

Planta 145:253-258.

- Muc, M. 1977. Ecology and primary production of sedge-moss meadow communities, Truelove Lowland. pp. 157-184. In: Truelove Lowland, Devon Island, Canada: A High Arctic Ecosystem. L.C. Bliss (ed.) University of Alberta Press, Edmonton.
- Muc, M. and L.C. Bliss. 1977. Plant communities of Truelove Lowland. pp. 143-154. In: Truelove Lowland, Devon Island, Canada: A High Arctic Ecosystem. L.C. Bliss (ed.) University of Alberta Press, Edmonton.
- Oland, K. 1963. Changes in the content of dry matter and major nutrient elements of apple foliage during senescence and abscission. *Physiol. Plant.* 16:682-694.
- Parker, G.R. 1977. The flowering phenology of common vascular plants at Bailey Pt., Melville Island, N.W.T. *Can. Field Nat.* 91:81-83.
- Parker, J. 1958. Changes in sugars and nitrogenous compounds of tree bark from summer to winter. *Naturwissenschaften* 45:139.
- Parsons, L.R. 1978. Water relations, stomatal behavior and root conductivity of red osier dogwood during acclimation to freezing temperatures. *Plant Physiol.* 62:64-70.
- Parsons, L.R. and P.H. Li. 1979. Changes in frost hardiness of stem cortical tissues of *Cornus stolonifera* Michx. after recovery from water stress. *Plant Physiol.* 64:351-353.
- Paulsen, G.M. 1968. Effect of photoperiod and temperature on cold hardening in winter wheat. *Crop Sci.* 8:29-32.
- Pate, J.S. 1975. Exchange of solutes between phloem and xylem and circulation in the whole plant. pp. 451-473. In: *Encyclopedia of Plant Physiology, New Series*. vol. 1. Transport in Plants. I. Phloem Transport. M.H. Zimmermann and J.A. Milburn (eds.). Springer-Verlag, New York.

- Perry, T.O. 1971. Dormancy of trees in winter. *Science* 171:24-36.
- Pisek, A., W. Larcher, A. Vegis and K. Napp-Zinn. 1973. The normal temperature range, pp.102-194. *In: Temperature and Life*. H. Precht, J. Christophersen, H. Hensel, W. Larcher (eds.). Springer-Verlag, New York.
- Pisek, A. und Schiessel. 1946. Die Temperaturbeeinflussbarkeit der Frosthärte von Nadelhölzern und Zwergsträuchern an der alpinen Waldgrenze. *Ber. d. naturwiss.-mediz. Ver. Innsbruck* 47:33-52.
- Powell, J.M. 1961. The vegetation and micro-climate of the Lake Hazen area, northern Ellesmere Island, N.W.T. Defence Research Board of Canada. Dep. Nat. Def. D. Phys. R(G) Hazen 14, 112 pp.
- Raven, J.A. 1975. Transport of indoleacetic acid in plant cells in relation to pH and electrical potential gradients and its significance for polar IAA transport. *New Phytol.* 74:163-172.
- Rawson, H.M. and R.G. Woodward. 1976. Photosynthesis and transpiration in dicotyledonous plants. I. Expanding leaves of tobacco and sunflower. *Aust. J. Plant Physiol.* 3:247-256.
- Roberts, S.W. and K.R. Knoerr. 1977. Components of water potential estimated from xylem pressure measurements in five tree species. *Oecologia* 28:191-202.
- Robinson, N. (ed.). 1966. *Solar Radiation*. Elsevier, New York.
- Running, S.W. 1976. Environmental control of leaf water conductance in conifers. *Can. J. For. Res.* 6:104-112.
- Russel, R. Scott. 1940. Physiological and ecological studies on an arctic vegetation. III. Observations on carbon assimilation, carbohydrate storage and stomatal movement in relation to the growth of plants on Jan Mayen Island. *J. Ecol.* 28:289-309.

- Sakai, A. 1962. Studies on the frost-hardiness of woody plants. I. The causal relation between sugar content and frost-hardiness. Contr. Inst. Low Temp. Sci. Ser. B11, 1-40.
- Sakai, A. 1966. Studies of frost hardiness in woody plants. II. Effect of temperature on hardening. Plant Physiol. 41:353-359.
- Sakai, A. 1970. Freezing resistance in willows from different climates. Ecology 51:485-491.
- Sakai, A. 1973. Characteristics of winter hardiness in extremely hardy twigs of woody plants. Plant Cell Physiol. 14:1-9.
- Sakai, A. and K. Otsuka. 1970. Freezing resistance of alpine plants. Ecology 51:665-671.
- Sakai, A. and C.J. Weiser. 1973. Freezing resistance of trees in N. America with reference to tree regions. Ecology 54:118-126.
- Sakai, A. and S. Yoshida. 1968. The role of sugar and related compounds in variations of freezing resistance. Cryobiology 5:160-174.
- Salisbury, F.B. and C.W. Ross. 1978. Plant Physiology 2nd. ed. Wadsworth-Pub. Co. Belmont, Ca.
- Sands, K. and A.J. Rutter. 1958. The relation of leaf water deficit to soil moisture tension in *Pinus sylvestris* L. II. Variation in the relation caused by developmental and environmental factors. New Phytol. 57:50-65.
- Savile, D.B.O. 1972. Arctic Adaptations in Plants. Plant Res. Inst. Monograph No. 6. Canada Dept. of Agriculture, Ottawa.
- Sawhney, R. 1977a. Nature of light requirement for the flowering of *Chenopodium rubrum* L. (ecotype 60°47' N). I. Induction of flowering in continuous light. Planta 133:107-109.

- Sawhney, R. 1977b. Nature of light requirement for the flowering of *Chenopodium rubrum* L. (ecotype 60°47'N). II. Post-induction light period. *Planta* 133:103-106.
- Sawhney, R. 1977c. Nature of light requirement for the flowering of *Chenopodium rubrum* L. (ecotype 60°47'N). I. Pre-induction period. *Planta* 133:97-102.
- Schulze, G.A. 1949. Reactions of woody species on a continuous summer day. *Doklady Akad. Nauk. S.S.S.R.* 66:985-988.
- Schulze, E.-D., O.L. Lange, L. Kappen, U. Buschbom and M. Evenari. 1973. Stomatal responses to changes in temperature at increasing water stress. *Planta* 110:29-42.
- Schwarz, W. 1970. Der Einfluss der Photoperiode auf das Austreiben die Frosthärte und die Hitzeresistenz von Zirben und Alpenrosen. *Flora* 159:258-285.
- Selby, J.E.A. and R.A. McClatchey. 1975. Atmospheric transmittance from 0.25 to 28.5 μm . Computer code LOWTRAN 3, Air Force Cambridge Research Laboratories, AFCL-TR-75-0255.
- Siminovitch, D., F. Gfeller and B. Rheaume. 1967. The multiple character of the biochemical mechanism of freezing resistance of plant cells. pp. 93-117. In: *Cellular Injury and Resistance in Freezing Organisms*. E. Asahina (ed.). Inst. Low Temp. Sci. Hokkaido University, Sapporo.
- Siminovitch, D., J. Singh and I.A. de la Roche. 1975. Studies on membranes in plant cells resistant to extreme freezing. I. Augmentation of phospholipids and membrane substance without changes in unsaturation of fatty acids during hardening of black locust bark. *Cryobiology* 12:144-153.
- Smith, H. 1975. *Phytochrome and Photomorphogenesis*. McGraw-Hill, London.
- Smith, H. and M.G. Holmes. 1977. The function of phytochrome in the natural environment - III. Measurement and

calculation of phytochrome photoequilibria. *Photochem. and Photobiol.* 25:547-550.

Sokal, R.R. and F.J. Rohlf. 1969. *Biometry; the principles and practice of statistics in biological research.* W.H. Freeman, San Francisco.

Solárová, J. 1973. changes in minimal diffusive resistances of leaf epidermes during aging of primary leaves of *Phaseolus vulgaris* L. *Biol. Plant.* 15:237-240.

Sørensen, T. 1941. Temperature relations and phenology of the northeast Greenland flowering plants. *Medd. om Grønland* 125:1-305.

Spomer, G. 1979. Prospects of hormonal mechanisms in cold adaptations of arctic plants. pp. 311-322. *In: Comparative Mechanisms of Cold Adaptations.* L.S. Underwood, L.L. Tieszen, A.B. Callahan and G.E. Folk (eds.). Academic Press, New York.

Stanhill, G. and M. Fuchs. 1977. The relative flux density of photosynthetically active radiation. *J. Appl. Ecol.* 14:317-322.

Steponkus, P.L. and F.O. Lanphear. 1967. Refinement of the triphenyl tetrazolium chloride method of determining cold injury. *Plant Physiol.* 42:1423-1426.

Stergios, B.G. and G.S. Howell, Jr. 1973. Evaluation of viability tests on cold stressed plants. *J. Am. Soc. Hort. Sci.* 98:325-330.

Stoner, W.A. and P.C. Miller. 1975. Water relations of plant species in the wet coastal tundra at Barrow, Alaska. *Arctic and Alpine Res.* 7:109-124.

Svoboda, J. 1974. Primary Production Processes within polar semi-desert vegetation, Truelove Lowland, Devon Island, N.W.T. Canada. Ph.D. thesis, University of Alberta, Edmonton.

Svoboda, J. 1977. Ecology and primary production of raised beach communities, Truelove Lowland. pp. 185-216. *In:*

Truelove Lowland, Devon Island, Canada: A High Arctic Ecosystem. L.C. Bliss (ed.) University of Alberta Press, Edmonton.

Szeicz, G. 1974. Solar radiation for plant growth. *J. Appl. Ecol.* 11:617-636.

Tal, M. and O. Imber. 1971. Abnormal stomatal behavior and hormonal imbalance in flacca, a wilted mutant of tomato. III. Hormonal effects on the water status in the plant. *Plant Physiol.* 47:840-850.

Teeri, J.A. 1972. Microenvironmental adaptations of local populations of *Saxifraga oppositifolia* in the High Arctic. Ph.D. thesis, Duke University, Durham.

Teeri, J.A. 1973. Polar desert adaptations of a high arctic plant species. *Science* 179:496-497.

Teeri, J.A. 1974. Periodic control of flowering of a high arctic plant species by fluctuating light regimes. *Arctic and Alpine Res.* 6:275-280.

Teeri, J.A. 1976. Phytotron analysis of a photoperiodic response in a high arctic plant species. *Ecology* 57:374-379.

Thekaekara, M.P. 1973. Solar energy outside the earth's atmosphere. *Solar Energy* 14:109-127.

Tieszen, L.L. 1973. Photosynthesis and respiration in arctic tundra grasses: field light intensity and temperature responses. *Arctic and Alpine Res.* 5:239-251.

Tieszen, L.L. 1975. CO₂ exchange in the alaskan arctic tundra: seasonal changes in the rate of photosynthesis of four species. *Photosynthetica* 9:376-390.

Tieszen, L.L. 1978. Photosynthesis in the principle Barrow, Alaska species: a summary of field and laboratory responses. pp. 241-268. *In: Vegetation and Production Ecology of an Alaskan Arctic Tundra.* L.L. Tieszen (ed.). Springer-Verlag, New York.

- Trewavas, A.J. 1976. Plant growth substances. pp. 249-298.
In: Molecular Aspects of Gene Expression in Plants. J.A. Bryant (ed.). Academic Press, New York.
- Tumanov, I.I. and O.A. Krasavtsev. 1959. Hardening of northern woody plants by temperatures below zero. Soviet Plant Physiol. 6:663-673.
- Turner, N.C. and G.H. Heichel. 1977. Stomatal development and seasonal changes in diffusive resistance of primary and regrowth foliage of red oak (*Quercus rubra* L.) and red maple (*Acer rubrum* L.). New Phytol. 78:71-81.
- Tyree, M.T., N.S. Cheung, M.E. MacGregor and A.J.B. Talbot. 1978. The characteristics of seasonal and ontogenetic changes in the tissue-water relations of *Acer*, *Populus*, *Tsuga* and *Picea*. Can. J. Bot. 56:635-647.
- Ulmer, W. 1937. Über den Jahresgang der Frosthärte einiger immergrüner Arten der alpinen Stufe, sowie der Zirbe und Fichte. Jahrb. wiss. Bot. 64:553-592.
- Vaartaja, O. 1959. Evidence of photoperiodic ecotypes in trees. Ecol. Monogr. 29:91-111.
- van Huystee, R.B., C.J. Weiser and P.H. Li. 1967. Cold acclimation in *Cornus stolonifera* under natural and controlled photoperiod and temperature. Bot. Gaz. 128:200-205.
- Vince-Prue, D. 1975. Photoperiodism in Plants. McGraw-Hill, London.
- Voskresenskaya, N.P. 1972. Blue light and carbon metabolism. Ann. Rev. Plant Physiol. 23:219-234.
- Voskresenskaya, N.P. 1979. Effects of light quality on carbon metabolism. pp. 176-180. In: Encyclopedia of Plant Physiology, New Series. vol. 6. Photosynthesis II. M. Gibbs and E. Latzko (eds.). Springer-Verlag, New York.
- Vowinckel, E. 1962. Cloud amount and type over the Arctic. Arctic Meteorology Research Group, Publication in

Meteorology No. 51. Dept. of Meteorology, McGill University.

- Vowinckel, E. and S. Orvig. 1962. Insolation and absorbed solar radiation at the ground in the Arctic. Arctic Meteorology Research Group, Publication in Meteorology No. 53. Dept. of Meteorology, McGill University.
- Waggoner, P.W. and N.C. Turner. 1971. Transpiration and its control by stomata in a pine forest. Conn. Agric. Exp. Stn. Bull. 726.
- Walker, B.D. and T.W. Peters. 1977. Soils of Truelove Lowland and plateau. pp. 31-62. *In*: Truelove Lowland, Devon Island, Canada: A High Arctic Ecosystem. L.C. Bliss (ed.) University of Alberta Press, Edmonton.
- Wareing, P.F. 1956. Photoperiodism in woody plants. *Ann. Rev. Plant Physiol.* 7:191-214.
- Warren Wilson, J. 1957. Observations on the temperatures of arctic plants and their environments. *J. Ecol.* 45:499-531.
- Warren Wilson, J. 1959. Notes on wind and its effects on arctic and alpine vegetation. *J. Ecol.* 47:415-427.
- Weiser, C.J. 1968. Endogenous control of cold acclimation in woody plants. *Cryobiology* 4:277.
- Weiser, C.J. 1970. Cold resistance and injury in woody plants. *Science* 169:1269-1278.
- Welch, R.M., S.K. Cox and J.M. Davis. 1980. Solar radiation and clouds. *Meteorological Monographs* 17:39. Amer. Met. Soc., Boston.
- Wilding, M.D., M.A. Stahmann and D. Smith. 1960. Free amino acids in alfalfa as related to cold hardiness. *Plant. Physiol.* 35:726-732.
- Wildung, D.K., C.J. Weiser and H.M. Pellet. 1973. Temperature and moisture effects on hardening of apple

- roots. Hortscience 8:53-55.
- Wilkinson, A.J. 1977. Physiological aspects of the cold hardiness of *Ledum groenlandicum*. M.Sc. thesis, University of Alberta, Edmonton.
- Williams, B.J. Jr., N.E. Pellett and R.M. Klein. 1972. Phytochrome control of growth cessation and initiation of cold acclimation in selected woody plants. Plant Physiol. 50:262-265.
- Woodward, R.G. and H.M. Rawson. 1976. Photosynthesis and transpiration in dicotyledonous plants. II. Expanding and senescing leaves of soybean. Austral. J. Plant Physiol. 3:257-267.
- Zahner, R., J.E. Lotan and W.D. Baughman. 1964. Earlywood-latewood features of red pine grown under simulated drought and irrigation. Forest Sci. 10:361-370.
- Zalenskij, O.V., V.M. Shvetsova and V.L.Voznessenskij. 1971. Photosynthesis of some plants of Western Taimyr. pp. 182-186. In: Tundra Biome Proceedings IV. International meeting on the biological productivity of tundra. Leningrad U.S.S.R. October 1971. F.E. Wielgolaski and Th. Rosswall (eds.).
- Zelitch, I. 1969. Stomatal control. Ann. Rev. Plant Physiol. 20:329-350.
- Zimmermann, M.H. 1964. The formation of wood in forest trees. Academic Press, New York.

VI. Appendices

Appendix 1

a. Transmittance characteristics of the broadband (400-500 nm) filter.

b. Design of special light sensors.

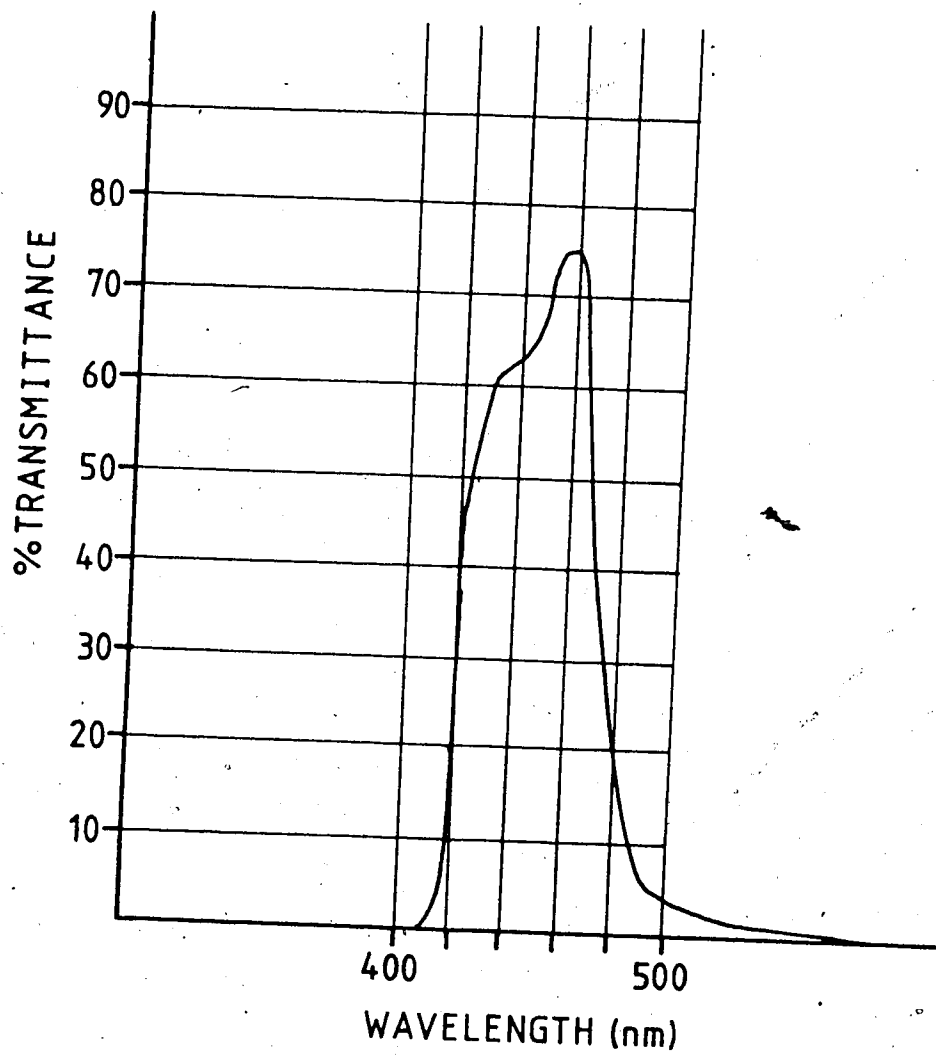

Fig. 41. Transmittance characteristics of the wideband filter used in the blue sensor.

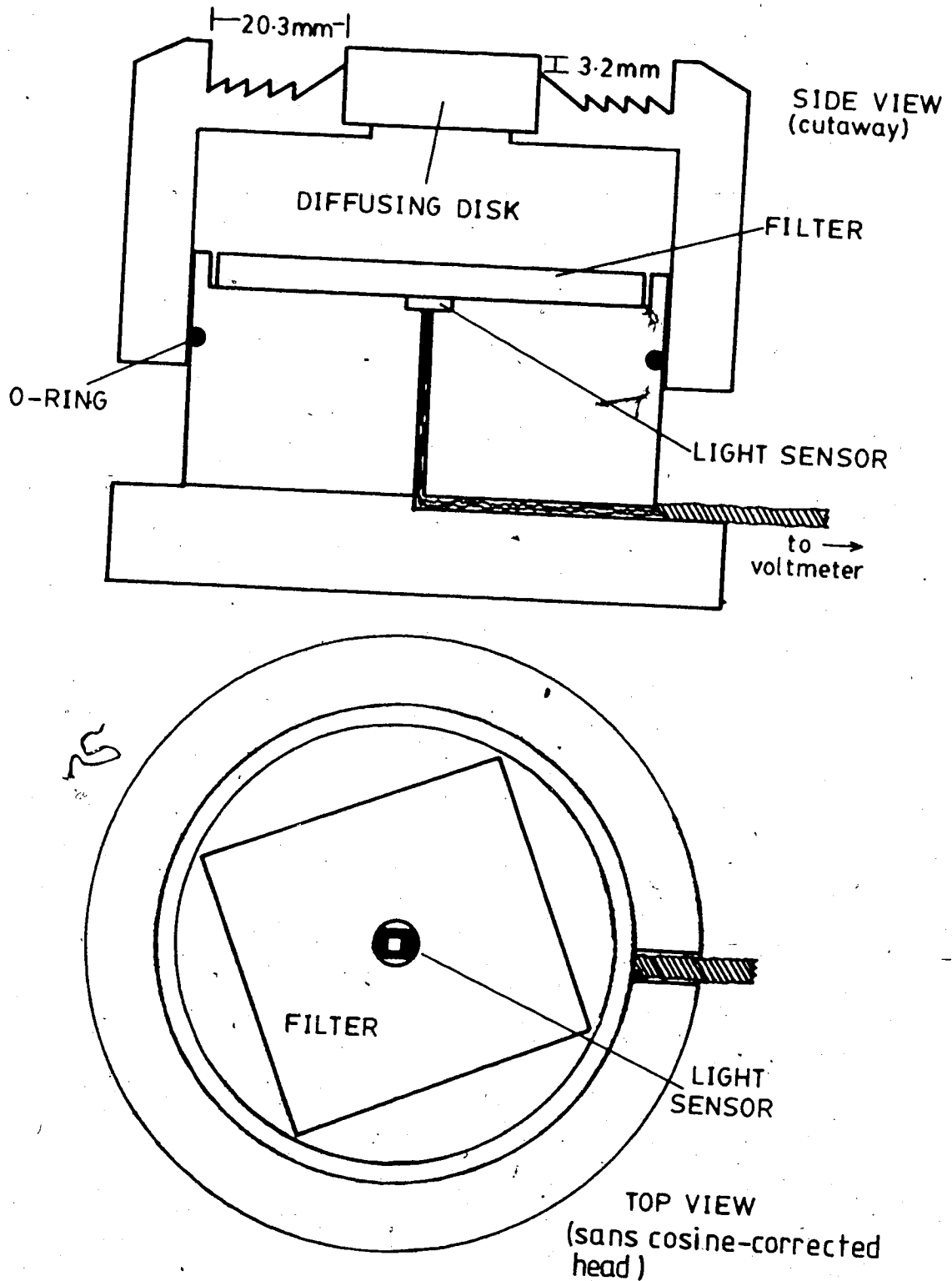

Fig. 42. Internal design of the wavelength-selective light sensors. In the side view, the cosine-corrected sensor head is shown at an intermediate position above the filter and solar cell. The two design parameters critical to a good cosine response are shown. Scale is 1:1.

Appendix 2

Cosine response of the narrow waveband light sensors.

Cosine response of the ISCO spectroradiometer.

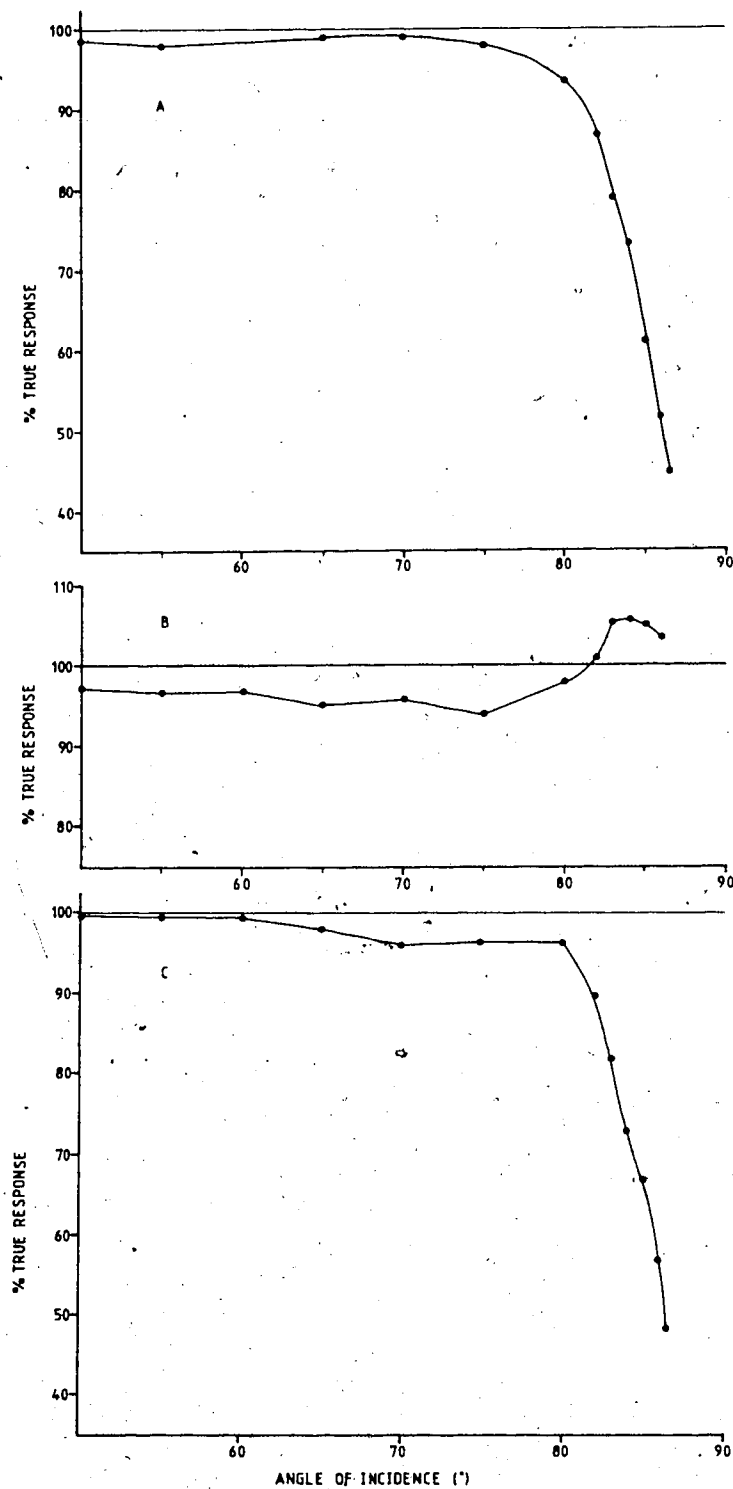

Fig. 43. Cosine response of the A) 660 nm, B) 730 nm and C) 400-500 nm sensors, expressed as percentage of true response.

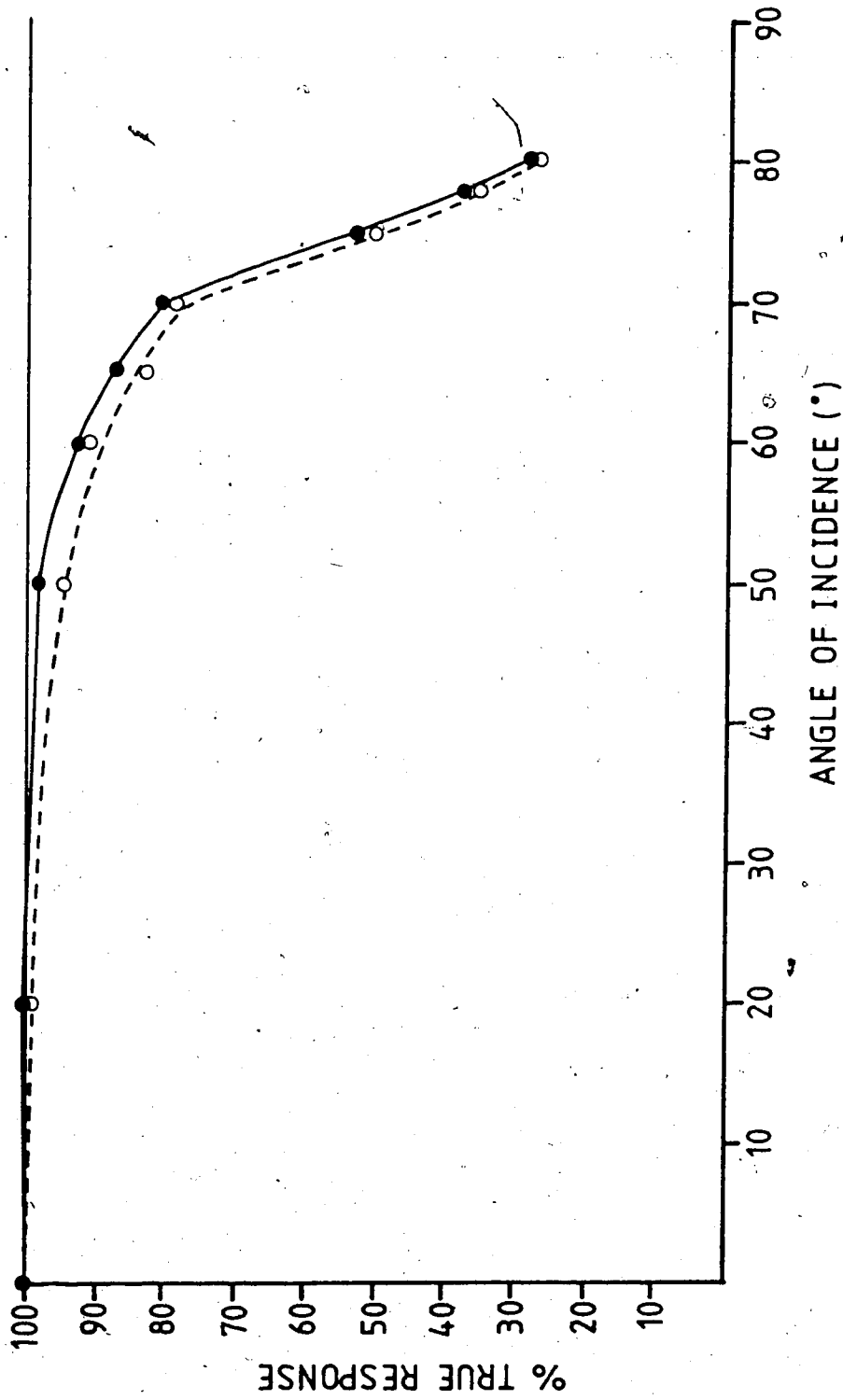

Fig. 44. Cosine response of the ISCO spectroradiometer at 660 (●) and 730 (○) nm wavelengths, expressed as percentage of true response.

Appendix 3

Application of a radiation model to the calculation of zeta and red:blue ratios in the High Arctic.

The Model Applied to Arctic Conditions

Leckner (1978) deals with the elements of his radiation model by considering each spectral transmittance function in turn. The same will be done here as they apply to the 660 nm and 730 nm wavelengths under arctic conditions.

At a given wavelength λ_j , the radiation incident on a plane normal to the sun's rays at the bottom of the atmosphere is

$$(1) \quad E_j = E_{oi} \omega_{oi} \omega_{gi} \omega_w \omega_{ri} \omega_{ai}$$

The red and far-red values of E_{oi} , the extraterrestrial irradiance, were obtained from Thekaekera (1973). The spectral transmittance functions of Rayleigh scattering (ω_r), ozone absorption (ω_{oz}), uniformly mixed gases absorption (of carbon dioxide, oxygen, etc.) (ω_g), water absorption (ω_w) and aerosal attenuation (ω_a), are all functions of relative air mass (m) as well as wavelength. The calculated hourly solar zenith angles at Truelove were obtained from Whitfield (unpub. data). Values of relative air mass corresponding to the solar zenith angles were obtained from List (1949).

The Rayleigh scattering transmittance function used was

$$\omega_r = \exp\{-0.008735 \lambda^{-4.06} mP/P_o\} \quad (\text{Leckner 1978})$$

where $P_o = 101.3$ kPa and P was the average air pressure at base camp during July and August of 1978 (100.2 kPa). Day to day variations in air pressure had very little effect on predicted zeta values.

The ozone absorption coefficients, k , were obtained

from Leckner (1978) for use in the transmittance function

$$\omega_{oz} = \exp\{-k(\lambda)\epsilon\}.$$

The amount of atmospheric ozone, ϵ , expressed as cm at normal temperature and pressure, varies seasonally, particularly at high latitudes. However, based on the values compiled by Robinson (1966), the approximate variation in ozone between July and August at 75° N is only 10%, which results in a maximum difference of 2% in the final red:far-red ratios. Therefore a constant value of 0.31 was used in the calculations.

The combination of a paucity of arctic data and locally varying conditions makes the calculation of the transmission function for aerosol scattering approximate at best. The expression used, $\omega_a = \exp\{-\rho\lambda^{-\alpha}\}$, contains a wavelength coefficient, α , and a turbidity coefficient, ρ . In keeping with Leckner (1978), an α of 1.3 was used, as recommended by Angström (1961), and adopted for the Angström method of measuring the turbidity coefficient. However, Leckner (1978) notes the wide range in reported values for α , and McCartney and Unsworth (1978) have tabulated means and ranges of α from a variety of sites. These include values well above (3.3) and well below (-0.5) that used here. The value of 1.3, therefore, is necessarily an approximation.

The turbidity coefficient, ρ , is basically a function of haze and aerosol particles, and involves both scattering and absorption of light (Angström 1961). Consequently, values tend to be higher in populated areas and lower in

cleaner, isolated areas. Although Vowinckel and Orvig (1962) in their calculation of arctic insolation discounted aerosol attenuation altogether due to the supposed very clean arctic atmosphere, other researchers have quoted a variety of values for both arctic (Angström 1961, Robinson 1966) and Antarctic (Fischer 1967, Kuhn 1972) environments. The value of 0.035 used here was obtained from Figure 2 in Angström (1961) for a latitude of 75° N. Although this value is somewhat arbitrary due to the absence of actual data from Truelove, it fits well among results of other arctic and Antarctic studies. Robinson (1966) gives a range of 0.009-0.094 for ρ , with an average value of 0.047 at latitude 70° N. Antarctic results are generally lower, possibly due to the greater isolation. Fischer (1967) cites values of 0.022 and 0.014 at McMurdo station (77° S) and 0.037 on the open sea at 71° S.

Leckner (1978) follows the work of McClatchey et. al. (1972) and Selby and McClatchey (1975) in obtaining the transmittance functions for water absorption,

$$\omega_w = \exp\{-(0.3k_w X_w m)/(1+25.25k_w X_w m)\}.$$

Here k_w is the effective absorption coefficient of water vapor and X_w is the pathlength for water vapor in $g\ cm^{-2}$. Since there is no absorption by water at 660 nm, this function was only applicable to far-red light. A k_w value of .87 was obtained from Leckner (1978) for 730 nm.

Again, another unknown seasonal variable, X_w , had to be estimated from either average tabular values or standard

meteorological data. In the former case, Robinson (1966) lists 1.80 cm as the average amount of precipitable water at 70° N, and this value was used for predictions of zeta in August ($X_w=1.43$). Leckner (1978) provides an alternate method for determining X_w using relative humidity and absolute temperature, and this was used to calculate zeta in July. There is danger, in using data from local ground conditions to estimate the water content of the entire atmosphere above. Using met data from the hygromograph, a value of 1.22 cm of precipitable water ($X_w=0.97$) was used for early July. With more open ocean water in August it is likely that the total precipitable water was less in July, and if Robinson's estimate of 1.80 cm ($X_w=1.43$) is used for August the effects of assuming higher atmospheric water content can be tested. Thus, an X_w of 0.97 and 1.43 was used for July and August, respectively. The effect (Fig. 14) was to shift zeta upward by 0.02 (1.8%) in August.

The transmittance function for absorption by atmospheric gases (ω_g) is unity for 660 and 730 nm since no absorption occurs in the visible wavelengths.

The direct solar radiations was calculated (Equation (1)) for 660 and 730 nm for a range of air mass values (1.62-15.36) corresponding to the range of zenith angles occurring on Truelove during July and Early August (ca. 52-87°). The calculated diffuse sky radiation was added to these results.

The diffuse sky radiation D above a non-reflecting

ground, was determined for red and far-red light from

$$D = KE \cos z$$

where $E = E_{oi} \omega_{oi} \omega_{gi} \omega_{wi} - E_i$.

The given zenith angle is z and $K=0.5$ (Leckner 1978). From the sum of the direct and diffuse components, the ratio of predicted red and far-red radiation was determined for all relevant sun angles. The results were first converted from energy units ($W m^{-2} nm^{-1}$) to quanta ($\mu E m^{-2} s^{-1}$) before zeta was calculated. The ratios are found in Figure 14 of the Results and Discussion.

The assumption of a non-reflecting ground (albedo(A)=0) is, of course, not valid, particularly for an area where there is snow and sea ice present during much of the summer. However, the overall effect of this assumption on zeta may be small. Assuming an albedo of 0.6 for "normal" snow, Robinson (1966) shows that an underestimate in global radiation of ca. 6.6% will result if an albedo of zero is used instead (Fig. 45). Because it is a ratio, the difference disappears when zeta is calculated, if one assumes an equal reflectance of snow for red and far-red light. Krinov (1953) reported essentially equal reflectances (r) for all wavelengths in the 400-840 nm waveband for snow with a thin film of ice ($r=0.76$ for 660 and 730 nm). Dry snow with a crust was more variable, with the albedo depending on the azimuth and angle of view relative to the sun. In the extreme case the red and far-red reflectances differed by .23 ($r_{660}=0.65$, $r_{730}=0.42$) (Krinov 1953). This would

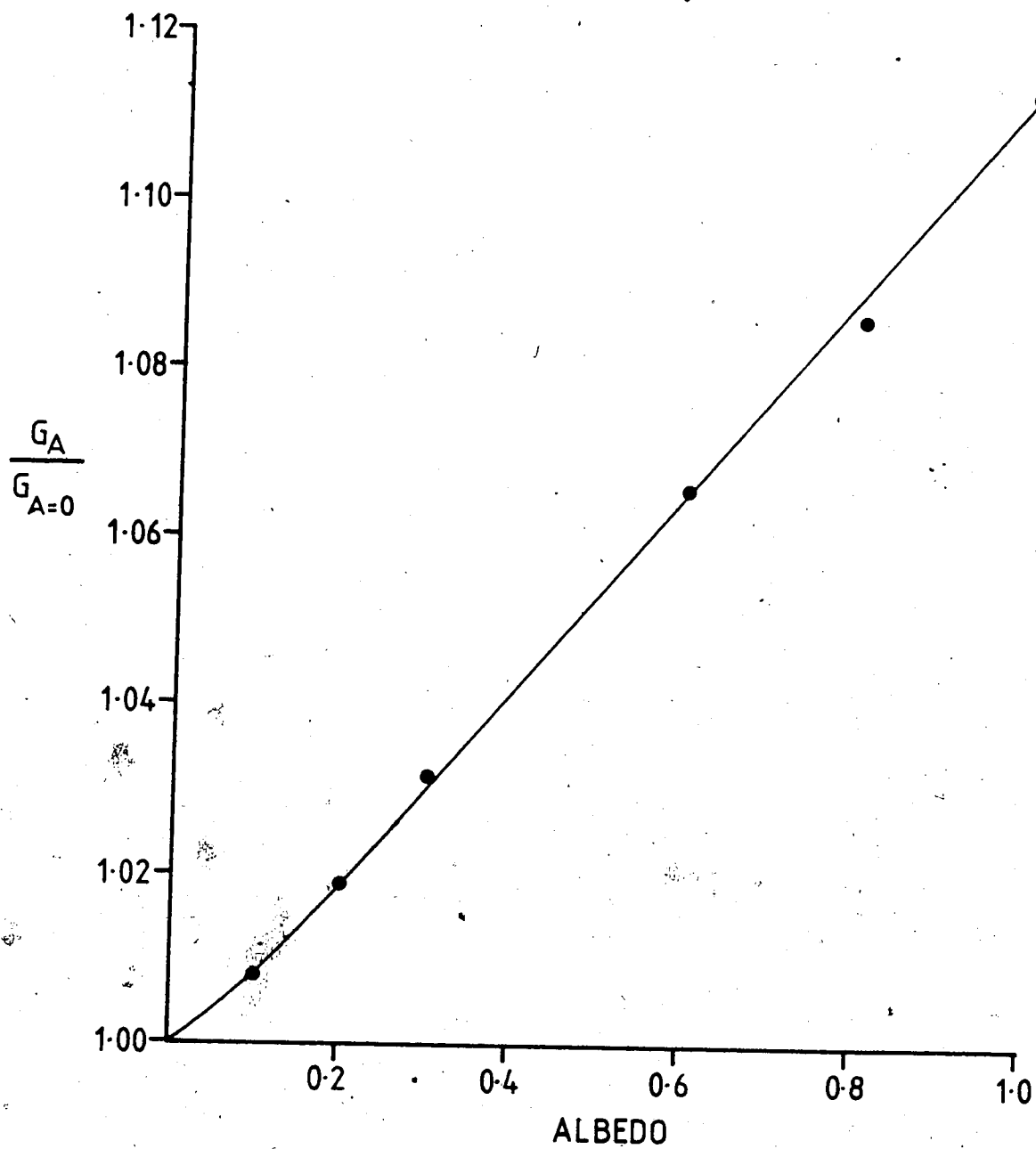

Fig. 45. The ratio of global radiation at a given albedo (A) to global radiation at $A=0$ ($G_A/G_{A=0}$) as a function of albedo for $\rho = 0.035$. Modified from Robinson (1966).

result in an increase in zeta relative to the values predicted from $A=0$. An error of greater magnitude, but causing a decrease in zeta, occurs if a sedge meadow is considered the primary reflecting surface, due to the higher albedo of grasses and sedges in the far-red region ($r_{660}=0.121$, $r_{750}=0.459$) (Krinov 1953). Using these values as the extreme examples, it is clear from Fig. 45 that increasing albedo from 0.12 to 0.46 results in an increase in global radiation of only ca. 4.5% when $\rho=0.035$. Therefore, it appears that, on the average, the differences in albedo of snow and sedges are insignificant with respect to the effects on zeta. Reflectances in the red and far-red range were very similar ($\Delta r=0.10$) for surfaces such as dry limestone, talus and cliffs, suggesting that little effect on zeta would result from these surfaces alone.

It is difficult to assess the relative contributions of the immediate vegetation, the surrounding ocean ice and the plateau on the red and far-red ratios. However, the magnitudes of possible error are small, and sometimes in opposite directions, so it is likely that the effects of spectral variation in albedo on global radiation are also small, under clear skies.

The above model does not take into account the radiation conditions under cloudy or overcast skies, or in fogs. There have been few reports of the spectral distribution under overcast skies (Archer 1978), and results from fogs and partly cloudy skies are variable (Arnulf and

Bricard 1957, Gates and Shaw 1960).

Loferski (1956) modified a 7000 K black body spectrum to use as an approximation of the spectral composition of an overcast sky. This results in a zeta of 1.09; the effects of changing sun angle are unclear. Others have assumed that the overcast sky has the same spectral quality as the diffuse radiation component on a clear day (Landsberg and Mallison 1975 cited by Archer 1978). This assumption gives a range of zeta much higher in magnitude and less in amplitude than obtained under clear skies (zeta=1.41-1.33 for $m=1.62-15.36$, respectively). Middleton (1954) developed a theory for the spectral irradiance of the overcast sky in terms of water droplet size and concentration, cloud thickness and incident radiation. He found the albedo of the ground to significantly affect the spectral composition of the overcast sky. Assuming stratus or stratocumulus cloud 1000m thick and composed of 10^8 drops per m^3 , each with an average radius of 7 microns (Welch et al. 1980), the effect of the ground albedo can be approximated according to Middleton (1954). In the case of snow covered ground, with $r_{660}=0.650$ and $r_{730}=0.420$, zeta is increased by a factor of 1.34. With sedge meadow below ($r_{660}=0.121$ and $r_{730}=0.459$) zeta is decreased by a factor of 0.73. The two factors are almost reciprocals. As mentioned earlier in regard to diffuse light, it is difficult to determine the relative importance of the two opposing tendencies on zeta. This is partially due to seasonally varying amounts of snow and vegetation, and

partially due to variation in cloud cover and type. The problem is considered again in the Results and Discussion.

A final consideration is the transmission of red and far-red light through hazes and fogs. Light fogs were common on the lowland, particularly at low sun angles (late night and early morning). Arnulf and Bricard (1957) found that transmission increased with wavelength in hazes, with poorest transmission between 400-550 nm. This suggests that a decrease in zeta would occur under hazy conditions relative to clear skies, though the amount of shift is unknown and not easily predicted. For fogs, transmission often decreased with increasing wavelength, though the type of fog was an important factor (Arnulf and Bricard 1957). In some cases the reverse relationship was true. It is impossible to state categorically whether transmittance in fogs is greater at 660 or 730 nm, since the relative transmittances reverse depending on conditions. In addition, at these wavelengths, the absolute differences in the transmission characteristics of fogs were often very small (see Arnulf and Bricard 1957), and this result together with the above facts makes any prediction of the effects of fogs on zeta uncertain.

The calculation of red:blue ratios (660:450 nm) proceeds in much the same way as that outlined for zeta determinations. The results are shown in Figure 16 of the Results and Discussion. The ozone absorption coefficient for

450 nm was taken from Leckner (1978) and water and gas absorption at this wavelength is absent. An important difference from the 660 and 730 nm wavelengths is the increasing importance of diffuse sky radiation with decreasing solar elevation. At a zenith angle (z) of 52° , diffuse radiation is 17.5% of the global radiation at 450 nm. By $z=81^\circ$ the percentage is 33% and it increases sharply to 79% at $z=87^\circ$. In contrast, the diffuse component of red and far-red radiation at $z=87^\circ$ are 9.9 and 6.4% of global radiation, respectively. With diffuse light contributing so heavily to global radiation at 430 nm, the albedo of the ground is likely an important factor. However, the albedos of snow and meadows are similar at the wavelengths of 450 and 660 nm. The albedo of snow varies with sun angle, but the maximum difference between the two wavelengths is only 0.11 ($r_{450}=0.740$; $r_{660}=0.630$). For sedge meadows, the absolute magnitudes as well as the relative differences are less ($r_{450}=0.047$; $r_{660}=0.121$). As before, the effects of these differences on red:blue ratios are in opposite directions; a prevalence of snow results in decreased red:blue values, while expanses of meadow favor higher ratios. On the latter point, it is likely that the increase in the red:blue values would be quite small due to the low albedo of sedges and the consequently very small amount of secondarily scattered radiation. Because of the uncertainty of the relative contributions of reflected radiation from snow and sedge, the amount and direction of change in red:blue ratios that

occurred due to secondary scattering is unclear.

Under cloudy skies, the predicted variation in red:blue ratios can be very different depending on the choice of assumptions. Because of the large contribution of diffuse light to the total incoming 450 nm radiation, the assumption that the spectral distribution of the overcast sky is the same as the diffuse component under clear skies (Landsberg and Mallison in Archer 1978) results in very much reduced red:blue ratios, both in magnitude and range. Between the zenith angles of 52° to 87° , the red:blue ratios range from 0.41 to 0.68. The values from Figure 16 range from 1.31 to 5.57. If Middleton's (1954) model of the overcast sky is used and assuming the same cloud parameters as earlier, direct beam red blue:ratios are reduced by a factor of 0.84 when snow is the primary reflecting surface, and increased by a factor of 1.06 when sedge predominates.

The trend under overcast skies might be towards a reduction in red:blue ratios, relative to clear skies, because the effect of snow is more pronounced than that of sedges, and the albedo of sedges is very small for both wavelengths (see above). Also, if there is any validity to the Landsberg and Mallison assumption, the ratios would be further reduced. More discussion is found in the Results and Discussion.