

Short Conceptual Overview

Guanqun Chen, Michael S. Greer and Randall J. Weselake*

Plant phospholipase A: advances in molecular biology, biochemistry, and cellular function

Abstract: Plant phospholipase As (PLAs) are a complex group of enzymes that catalyze the release of free fatty acids from phospholipids. Plant PLAs can be grouped into three families, PLA₁, PLA₂, and patatin-like PLA, that catalyze the hydrolysis of acyl groups from the *sn-1* and/or *sn-2* position. Each family is composed of multiple isoforms of phospholipases that differ in structural, catalytic, and physiological characteristics. In this review, recently acquired information on molecular, biochemical, and functional aspects of plant PLAs will be discussed.

Keywords: lipid biosynthesis; phospholipase; plant development; signal transduction; stress response.

*Corresponding author: **Randall J. Weselake**, Alberta Innovates Phytola Centre, Department of Agricultural, Food and Nutritional Science, 410 Agriculture/Forestry Centre, University of Alberta, Edmonton, Alberta, Canada T6G 2P5, e-mail: randall.weselake@ualberta.ca

Guanqun Chen and Michael S. Greer: Alberta Innovates Phytola Centre, Department of Agricultural, Food and Nutritional Science, 410 Agriculture/Forestry Centre, University of Alberta, Edmonton, Alberta, Canada T6G 2P5

Introduction

Enzymes of the phospholipase A (PLA) family catalyze the hydrolysis of acyl groups from phospholipids to produce free fatty acids and lysophospholipids. PLAs represent one of the earliest enzymes to be characterized, which traces back to the identification of lytic actions of snake venom at the end of the 19th century (1). Plants possess a complex and diverse set of PLA enzymes that differ in nucleotide sequence, protein structure, enzymatic properties, cellular functions, and anthropocentric applications (2–7). Here, we review the functions of plant PLAs, with particular focus on information acquired in the past 3 years.

Plant PLA genes and proteins

Defined by the bond that they work on, plants have three families of PLAs. PLA₁ and PLA₂ enzymes catalyze the hydrolysis of acyl groups from the *sn-1* and *sn-2* position, respectively, and patatin-like PLAs (pPLAs) exhibit activity toward both positions (Figure 1). It should be noted that this generally accepted classification system is convenient, but is neither very accurate nor broad enough to cover all enzymes with PLA activity. For instance, oleosin has recently been shown to be a bifunctional enzyme with both monoacylglycerol acyltransferase and PLA activities (8). Also, a lecithin:cholesterol acyltransferase (LCAT)-like PLA, which is not a pPLA, shows both PLA₁ and PLA₂ activities, with a preference for acyl groups at the *sn-2* position (9). In this review, this LCAT-PLA will be included in the discussion of the PLA₁ family, as it is the closest homologue of LCAT-PLA₁. Oleosin and other multifunctional enzymes with PLA activities will not be included in this review.

Fourteen genes encoding PLA_s have been identified in *Arabidopsis*, which can be divided into five classes based on the presence of particular N-terminal stretches and sequence similarities in the catalytic region (Table 1). All known plant PLA_s have molecular masses of 45–50 kDa, contain a conserved GX SXG motif, and have a catalytic triad composed of a serine, an aspartic acid, and a histidine residue (3). In contrast, their cellular localizations are diverse (4, 10–12). AtPLA₁-I α 1 is localized to cytoplasmatic lipid bodies that are often associated with chloroplasts, whereas the other six class I PLA_s are targeted to plastids (10–14). All four class II PLA_s are predicted to be localized to the cytosol, which has been demonstrated experimentally for AtPLA₁-II γ and AtPLA₁-II δ (4, 15, 16). AtPLA₁-III and AtPA-PLA₁ are localized to the mitochondria and vacuolar membranes, respectively (17, 18). The transcription of PLA₁ genes can be diverse as well. PLA₁ transcripts can generally be detected in almost all plant organs, but the individual isoforms vary considerably in their temporal or tissue specificity (11–15, 19). For example, AtPLA₁-III is highly expressed in seedlings.

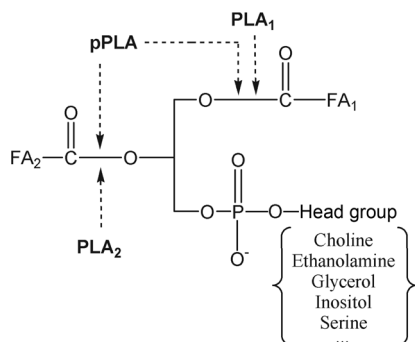

Figure 1 Positional specificity of plant phospholipase As (PLAs) on phospholipids. FA, fatty acyl chain; pPLA, patatin-like PLA. Some plant PLAs can also use glycolipids, lysophospholipids, and neutral glycerolipids as substrates (Table 1).

The carnation *PLA₁-II* is expressed in 4- to 5-day-old roots, whereas *LCAT-PLA* is expressed in both roots and developing siliques (9, 17, 19).

Plants have a relatively much simpler and less complex pool of ‘real’ PLA₂s (phospholipases that have only PLA₂ activity but no PLA₁ activity) compared with plant PLA₁s, and those from animals and other sources. Only four soluble PLA₂s have been identified in *Arabidopsis* (AtPLA₂-α, -β, -γ, and -δ) (6). Similar to animal secretory PLA₂s (*sPLA₂*s), all four of these PLA₂s have low molecular masses of 13–18 kDa. All of these plant *sPLA₂*s also contain a catalytic site DACCxxHDxC motif with a well-conserved histidine-aspartate dyad, and a calcium-binding loop (YGKYCGxxxxGC) (20). Regarding protein localization, AtPLA₂-α is localized to the Golgi, AtPLA₂-β and AtPLA₂-δ are localized to the endoplasmic reticulum, and AtPLA₂-γ is localized to both the endoplasmic reticulum and the Golgi (21–23). A recent study indicates that AtPLA₂-α can also be localized to the nucleus in the presence of AtMYB30 (24). The transcripts of *AtsPLA₂*s are tissue specific: *sPLA₂-α* is expressed in most tissues with the exception of siliques; the expression of *sPLA₂-β* can be detected in flowers and siliques but not in maturing seeds; *sPLA₂-δ* and -γ are only expressed in floral tissues (20, 25, 26). Recently, Kim et al. (23) used RT-PCR to compare the expression profiles of all four *AtsPLA₂*s in pollen. *AtsPLA₂-β*, -γ, and -δ, but not *AtsPLA₂-α*, were expressed in pollen, potentially indicating an important role for class II but not class I *sPLA₂*s in pollen development. Environmental conditions can also affect *sPLA₂* expression. For example, the expression of *Citrus sinensis sPLA₂-α* and *sPLA₂-β* exhibited diurnal rhythmicity in leaf and fruit tissues, suggesting accompanying daily cycle changes in second messengers (27).

Patatins are a group of vacuolar non-specific lipid hydrolases in tubers of solanaceous plants with combined

PLA₁, PLA₂, and galactolipase activities. *Arabidopsis* has 10 pPLA enzymes that can be divided into three classes based on their genomic sequences (Table 1). AtpPLA-I has a molecular mass of 156 kDa, which is much larger than the other AtpPLAs (averaging 45 kDa) (28). Class I and II pPLAs have a catalytic dyad, composed of a typical serine hydrolase motif of GX SXG, and a conserved aspartic acid within a patatin domain. The class III pPLAs, conversely, have a hydrolase motif sequence of GXGXG (5, 29, 30). The localizations of the six AtpPLAs have all been identified. AtpPLA-I is localized in the chloroplasts; pPLA-IIδ, ε, and γ are localized to the cytoplasm and associate with membranes such as plasma or endoplasmic reticulum membrane. pPLA-IIIβ associates with the plasma membrane, and pPLA-IIIδ is localized to both the plasma and intracellular membranes (28, 29, 31, 32). Similar to *sPLA₂*s, pPLAs have a range of expression profiles among different plant tissues (Table 1). For instance, *AtpPLA-IIγ* is expressed preferentially in flowers and siliques, but *AtpPLA-IIε* is mainly expressed in roots (28). *AtpPLA-IIIα* has the highest expression level in siliques, whereas the other three *AtpPLA-II*s are expressed predominantly in roots (31).

Enzymatic properties of plant PLAs

The enzymatic properties of several plant PLAs have been studied through recombinant expression in yeast or *Escherichia coli*. These enzymes exhibit a broad range of calcium dependencies, substrate specificities, and pH and temperature optimums.

In general, all the characterized PLA₁s are calcium independent, can use phosphatidylcholine (PC) as substrate, and prefer a pH in the range of 5.0–7.5. Individual PLA₁s, however, exhibit different catalytic properties. For instance, all AtPLA₁-I and AtPLA₁-III can use monogalactosyldiacylglycerol (MGDG), digalactosyldiacylglycerol (DGDG), and triacylglycerol (TAG) as substrates in addition to PC; however, AtLCAT-PLA₁ cannot catalyze the hydrolysis of non-phospholipid substrates (11, 17, 33). AtLCAT-PLA, a homologue of animal lysosomal PLA₂ (group XV), can use phospholipids but not lysophospholipids as substrates (9, 34).

The catalytic properties of the four *AtsPLA₂*s have been extensively characterized. As shown in Table 1, *AtsPLA₂-α*, -β, -δ, and -γ are all calcium dependent and can use PC and phosphatidylethanolamine (PE) as substrate; however, their optimal pH vary from 8.5 to 9.0, 6.0 to 7.0, 7.0 to 9.0, and 8.0 to 9.0, respectively (20, 35). Recently, *sPLA₂*s have also been characterized in other

Table 1 *Arabidopsis* phospholipases (AtPLAs).

Family ^a	Class	Gene ID (name)	Tissue-specific transcripts ^b	Protein location ^c	Substrate preference ^d	Representative physiological roles	References
PLA ₁	I	<i>At1g05800</i> (<i>AtPLA₁-1α1</i>)	L>Sd>St>F	LB	DAG>PC>MAG, TAG	Jasmonate formation, stress	(10–12, 49)
	I	<i>At2g31690</i> (<i>AtPLA₁-1α2</i>)	F>St>Sd, no L	P	DAG>MAG>PC>TAG	Senescence, stress	(10, 11, 14, 49)
	I	<i>At2g44810</i> (<i>AtPLA₁-1β1</i>)	F>>St, L, Sd	P	PC>DAG>MAG>TAG	Jasmonate formation, stress	(10, 11, 13)
	I	<i>At4g16820</i> (<i>AtPLA₁-1β2</i>)	F>Sd>>L>St	P	DAG>TAG>MAG>PC	Stress	(10–12, 49)
	I	<i>At1g06800</i> (<i>AtPLA₁-1γ1</i>)	L>Sd>F>St	P	TAG>DAG, MAG, PC	Jasmonate formation, stress	(11, 12, 49)
	I	<i>At2g30550</i> (<i>AtPLA₁-1γ2</i>)	St>L>Sd>F	P	TAG, DAG, MAG, PC	Stress	(11, 12, 49)
	I	<i>At1g51440</i> (<i>AtPLA₁-1γ3</i>)	F>L>>St>Sd	P	MAG>DAG>TAG>PC	Stress	(11, 12, 49)
	II	<i>At1g06250</i> (<i>AtPLA₁-11α</i>)	–	C	–	–	(4)
	II	<i>At2g31100</i> (<i>AtPLA₁-11β</i>)	–	C	–	–	(4)
	II	<i>At4g18550</i> (<i>AtPLA₁-11γ</i>)	St, Sd, Si>>F	C	DAG>MAG>LPC>>MGDG>PC>TAG	Storage oil metabolism	(4, 16)
	II	<i>At2g42690</i> (<i>AtPLA₁-11δ</i>)	–	C	PC>MAG>TAG	UV-B, Se	(4, 15)
	III	<i>At1g30370</i> (<i>AtPLA₁-111</i>)	Sd	M	LPC>MAG, PA>PC, PE>MGDG, DGDG>TAG, DAG	Seed germination, root development	(17)
	sPLA ₂	I	<i>At1g31480</i> (<i>AtPA-PLA₁</i>)	Rt>St, Sd, L>F	VM	–	Shoot gravitropism
I		<i>At3g03310</i> (<i>AtLCAT-PLA₁</i>)	–	es	PC>PE>PA>LPC	–	(33)
I		<i>At4g19860</i> (<i>AtLCAT-PLA₁</i>)	Rt>Si>L>St>F	C	PC>PA>PE>PG>PS	–	(9)
II		<i>At2g06925</i> (<i>AtsPLA₂-α</i>)	F, L, St, Rt	G, N	PE>PC	Protein trafficking, root	(20, 22, 24, 35)
II		<i>At2g19690</i> (<i>AtsPLA₂-β</i>)	F, Si	ER	PE>PC	Auxin signaling	(20, 21, 35)
II		<i>At4g29460</i> (<i>AtsPLA₂-γ</i>)	F	ER, G	PE>PC	Pollen development	(20, 23, 35)
II		<i>At4g29470</i> (<i>AtsPLA₂-δ</i>)	F	ER	PE>PC	Pollen development	(20, 23, 35)
I		<i>At1g61850</i> (<i>AtpPLA-1</i>)	Sh>Rt, F>>L	CHL	MGDG>DGDG>PG>>PI>PC	Jasmonate formation, stress	(28, 39)
II		<i>At2g26560</i> (<i>AtpPLA-11α</i>)	Rt>>F, L	mem	MAG>DAG>PE>PC	Oxylipin formation, stress	(30, 32)
II		<i>At5g43590</i> (<i>AtpPLA-11β</i>)	–	n	–	–	–
pPLA	II	<i>At4g37050</i> (<i>AtpPLA-11γ</i>)	F>Rt, St>L	PM, ER	PG>MGDG, DGDG>PC>PI	Root development, stress	(28, 32, 40)
	II	<i>At4g37070</i> (<i>AtpPLA-11ε</i>)	Rt	PM, ER	PG>MGDG>DGDG>PI>PC	Root development, stress	(28, 32, 40)
	II	<i>At4g37060</i> (<i>AtpPLA-11δ</i>)	Rt, L	PM, ER	PG>MGDG, PI>DGDG>PC	Root development, stress	(28, 32, 40)
	III	<i>At2g39220</i> (<i>AtpPLA-111α</i>)	Si>Rt>F, St, L	–	–	–	(31)
	III	<i>At3g54950</i> (<i>AtpPLA-111β</i>)	Rt>L>St>>F, Si	PM	PG, DGDG>PS, PA, MGDG, PE, PC	Cell elongation, cellulose, lipid	(31)
	III	<i>At4g29800</i> (<i>AtpPLA-111γ</i>)	Rt	–	–	–	(31)
	III	<i>At3g63200</i> (<i>AtpPLA-111δ</i>)	Rt>F>Si>>St	PM, IM	PC	Lipid synthesis	(29, 31)

^asPLA₂, secretory PLA₂; pPLA, patatin-related PLA.

^bF, flower; L, leave; Rt, root; S, seed; Sd, seedling; Sh, shoot; Si, silique; St, stem.

^cEnzyme locations demonstrated experimentally were labeled with capital letters. Predicted locations were marked with italic lowercase letters. C, cytosol; CHL, chloroplast; ER, endoplasmic reticulum; ES, extracellular space; G, Golgi apparatus; IM, intracellular membranes; LB, lipid bodies that are often associated with chloroplasts; M, mitochondria; MEM, membranes; N, nucleus; P, plastids; PM, plasma membrane; VM, vacuolar membranes.

^dSubstrate specificity may vary in different reactions conditions. Please check the references for the detailed reaction conditions. DAG, diacylglycerol; DGDG, digalactosyldiacylglycerol; LPC, lysophosphatidylcholine; MAG, monoacylglycerol; MGDG, monogalactosyldiacylglycerol; PA, phosphatidic acid; PC, phosphatidylcholine; PE, phosphatidylethanolamine; PG, phosphatidylglycerol; PI, phosphatidylinositol; PS, phosphatidylserine; TAG, triacylglycerol.

plants, including tobacco, soybean, and wheat (36–38). Interestingly, a purified tobacco class II sPLA₂, Nt1-PLA₂, showed both PLA₁ and PLA₂ activities (37). The authors used non-radiolabeled substrates in their enzyme assays, and then labeled the released fatty acids with 9-anthryldiazomethane for high-performance liquid chromatography analysis. As PLA₁ activity has never been reported for other plant sPLA₂s, it would be interesting to verify this result directly using radiolabeled substrates.

All three classes of pPLAs are capable of catalyzing the hydrolysis of phospholipids and other glycerolipids at both the *sn-1* and *sn-2* positions (3, 5, 29). AtpPLA-I, the only class I pPLA, preferentially catalyzes the hydrolysis of phosphatidic acid (PA) and phosphatidylserine (PS) at the *sn-2* position, and phosphatidylinositol (PI), PC, PE, and phosphatidylglycerol (PG) at the *sn-1* position. Furthermore, AtpPLA-I catalyzes the hydrolysis of MGDG four times faster than PG (39). Surveying class II pPLAs, AtpPLA-II α showed strong PLA₁ activity toward PC and PE; strong PLA₂ activity toward PG, PI, PA, and PS; and strong hydroxylase activity toward other membrane glycolipids, including MGDG, DGDG, and even oxidized glycolipids (30). AtpPLA-II γ , -II ϵ , and -II δ can act on glycolipids and phospholipids, but not on TAG (40). To describe class III pPLAs, AtpPLA-III β can catalyze the hydrolysis of phospholipids and glycolipids but not neutral lipids, and PA is the preferred substrate. AtpPLA-III δ has five times greater PLA₂ activity than PLA₁ activity when PC is used as a substrate. Although its activity toward other lipid classes has not been described, it would not be surprising if this enzyme could catalyze the hydrolysis of glycolipids and other phospholipids. Interestingly, both AtpPLA-III β and -III δ have thioesterase activity (29, 31).

Biological roles of plant PLAs

PLAs are involved in a wide range of cellular processes, many of which are believed to be linked to the accumulation of free fatty acids and lysophospholipids as either signaling molecules or building blocks in lipid metabolism (3, 4, 41). Here, we summarize the physiological aspects of plant PLAs with a focus on their recently identified roles (Table 1). Although some animal PLAs also have functions in signaling transduction and lipid metabolism, we cannot find similar biological roles of plant PLAs and their animal counterparts [for the functions of animal PLAs, please see ref. (42)].

During the past decade, substantial advances have been made toward understanding the biological functions

of plant PLA_s. Among class I PLA_s, AtPLA₁-I α 1, AtPLA₁-I β 1, and AtPLA₁-I γ 1 are important for jasmonic acid production (10, 12, 13). Class II PLA_s have numerous important roles, including ultraviolet B-induced defense signaling (AtPLA₁-II δ), onset of senescence (*Dianthus caryophyllus* PLA₁-II δ), seedling establishment (AtPLA₁-II γ), and also cell development and tissue growth (*Capsicum annuum* PLA₁-II γ) (15, 19, 43). The sole class III AtPLA₁, AtPLA₁-III, plays an important role in seed viability and longevity. Also, *AtPLA₁-III*-overexpressing lines possess significantly longer roots than the *atpla₁-iii* knockout or wild-type seedlings. Also, AtPLA₁-III may help protect and/or maintain seed contents that are important for germination, as *AtPLA₁-III*-overexpressing seeds showed a strong tolerance to accelerated-aging treatments (17). Regarding other PLA_s, AtPA-PLA₁ plays an important role in the early phases of shoot gravitropism (44). Although the enzymatic properties of AtLCAT-PLA₁ and AtLCAT-PLA have been reported, their functions in plants remain to be explored (9, 33).

Compared with other plant PLAs, sPLA₂s have been most extensively studied. To date, sPLA₂ enzymes have been shown to be involved in numerous developmental processes (4, 21, 22, 24, 26). For example, AtsPLA₂- α is required for the trafficking of PIN-FORMED proteins (auxin efflux transporters) to the plasma membrane, and may negatively regulate AtMYB30-mediated pathogen defense (22, 24). AtsPLA₂- β produces second messengers to enhance light-induced stomatal opening and also contributes to cell elongation and shoot gravitropism through the auxin signaling pathway (21, 26, 45). Additionally, all three class II sPLA₂s play critical roles in pollen development and pollen tube growth, most likely by modulating membrane deformation and enabling membrane trafficking (23).

Recent studies with transgenic plants indicate that the 10 plant pPLAs have unique yet overlapping functions. AtpPLA-I contributes to basal, but not pathogen- or wound-induced jasmonic acid production (39). Class II pPLAs modulate oxylipin formation (AtpPLA-II α), water loss (AtpPLA-II α), root development (AtpPLA-II γ and AtpPLA-II ϵ), and stress responses (AtpPLA-II α , AtpPLA-II α , and AtpPLA-II γ) (30, 40, 46–48). None of these pPLAs, however, are involved in providing free fatty acids for jasmonic acid biosynthesis (39). Among class III pPLAs, AtpPLA-III β was found to be involved in cell elongation, cellulose accumulation, and lipid metabolism (31). In T-DNA insertional knockout mutants of the four pPLA-IIIs, only the *ppla-iii δ* knockout mutant seeds had significantly lower oil contents. Conversely, when *pPLA-III δ* was overexpressed in *Arabidopsis*, the mutant had increased TAG

content, without detrimental effect on overall seed yield per plant (29). As AtpPLA-III β and AtpPLA-III δ have been reported to be involved in seed acyl lipid biosynthesis, further functional studies of lipid-hydrolyzing enzymes from other plants, particularly class III pPLAs, could better our understanding of lipid metabolism.

Conclusions and perspectives

Our understanding of plant PLAs has increased substantially over the past decade. A comprehensive and complex collection of PLAs have been identified, and further shown to exhibit a broad range of catalytic properties and biological functions. Some important questions, however, still remain. Further studies are

necessary to elucidate the precise role(s) of each individual PLA in the phospholipid signaling networks, the upstream and downstream targets of lipid products generated by plant PLAs, and the functions of PLAs in lipid metabolism.

Acknowledgments: This work is part of the European Commission Seventh Framework Programme-sponsored project: Industrial Crops producing value Oils for Novel chemicals (ICON). RJW is grateful for the support provided by AVAC Ltd., Alberta Enterprise and Advanced Education, Alberta Innovates Bio Solutions, the Canada Foundation for Innovation, and the Canada Research Chairs Program.

Received May 7, 2013; accepted June 25, 2013

References

- Stephens JWW, Myers W. The action of cobra poison on the blood: a contribution to the study of passive immunity. *J Pathol Bacteriol* 1898; 5: 279–301.
- Wang X. Plant phospholipases. *Annu Rev Plant Physiol Plant Mol Biol* 2001; 52: 211–31.
- Chen G, Snyder CL, Greer MS, Weselake RJ. Biology and biochemistry of plant phospholipases. *Crit Rev Plant Sci* 2011; 30: 239–58.
- Ryu SB. Phospholipid-derived signaling mediated by phospholipase A in plants. *Trends Plant Sci* 2004; 9: 229–35.
- Scherer GFE, Ryu SB, Wang XM, Matos AR, Heitz T. Patatin-related phospholipase A: nomenclature, subfamilies and functions in plants. *Trends Plant Sci* 2010; 15: 693–700.
- Wang G, Ryu S, Wang X. Plant phospholipases: an overview. *Methods Mol Biol* 2012; 861: 123–37.
- Casado V, Martin D, Torres C, Reglero G. Phospholipases in food industry: a review. *Methods Mol Biol* 2012; 861: 495–523.
- Parthibane V, Rajakumari S, Venkateshwari V, Iyappan R, Rajasekharan R. Oleosin is bifunctional enzyme that has both monoacylglycerol acyltransferase and phospholipase activities. *J Biol Chem* 2012; 287: 1946–54.
- Chen G, Greer MS, Lager I, Yilmaz JL, Mietkiewska E, Carlsson AS, Stymne S, Weselake RJ. Identification and characterization of an LCAT-like Arabidopsis thaliana gene encoding a novel phospholipase A. *FEBS Lett* 2012; 586: 373–7.
- Ellinger D, Stingl N, Kubigsteltig II, Bals T, Juenger M, Pollmann S, Berger S, Schuenemann D, Mueller MJ. Dongle and defective in anther Dehiscence1 lipases are not essential for wound- and pathogen-induced jasmonate biosynthesis: redundant lipases contribute to jasmonate formation. *Plant Physiol* 2010; 153: 114–27.
- Seo YS, Kim EY, Kim JH, Kim WT. Enzymatic characterization of class I DAD1-like acyl hydrolase members targeted to chloroplast in Arabidopsis. *FEBS Lett* 2009; 583: 2301–7.
- Hyun Y, Choi S, Hwang HJ, Yu J, Nam SJ, Ko J, Park JY, Seo YS, Kim EY, Ryu SB, Kim WT, Lee YH, Kang H, Lee I. Cooperation and functional diversification of two closely related galactolipase genes for jasmonate biosynthesis. *Dev Cell* 2008; 14: 183–92.
- Ishiguro S, Kawai-Oda A, Ueda J, Nishida I, Okada K. The defective in anther dehiscence1 gene encodes a novel phospholipase A₁ catalyzing the initial step of jasmonic acid biosynthesis, which synchronizes pollen maturation, anther dehiscence, and flower opening in Arabidopsis. *Plant Cell* 2001; 13: 2191–209.
- Padham AK, Hopkins MT, Wang TW, McNamara LM, Lo M, Richardson LGL, Smith MD, Taylor CA, Thompson JE. Characterization of a plastid triacylglycerol lipase from Arabidopsis. *Plant Physiol* 2007; 143: 1372–84.
- Lo M, Taylor C, Wang L, Nowack L, Wang TW, Thompson J. Characterization of an ultraviolet B-induced lipase in Arabidopsis. *Plant Physiol* 2004; 135: 947–58.
- Kim EY, Seo YS, Kim WT. AtDSEL, an Arabidopsis cytosolic DAD1-like acylhydrolase, is involved in negative regulation of storage oil mobilization during seedling establishment. *J Plant Physiol* 2011; 168: 1705–9.
- Seo YS, Kim EY, Kim WT. The Arabidopsis sn-1-specific mitochondrial acylhydrolase AtDLAH is positively correlated with seed viability. *J Exp Bot* 2011; 62: 5683–98.
- Morita MT, Kato T, Nagafusa K, Saito C, Ueda T, Nakano A, Tasaka M. Involvement of the vacuoles of the endodermis in the early process of shoot gravitropism in Arabidopsis. *Plant Cell* 2002; 14: 47–56.
- Seo YS, Kim EY, Mang HG, Kim WT. Heterologous expression, and biochemical and cellular characterization of CaPLA₁ encoding a hot pepper phospholipase A1 homolog. *Plant J* 2008; 53: 895–908.
- Lee HY, Bahn SC, Shin JS, Hwang I, Back K, Doelling JH, Ryu SB. Multiple forms of secretory phospholipase A₂ in plants. *Prog Lipid Res* 2005; 44: 52–67.

21. Seo J, Lee HY, Choi H, Choi Y, Lee Y, Kim YW, Ryu SB. Phospholipase A₂-b mediates light-induced stomatal opening in Arabidopsis. *J Exp Bot* 2008; 59: 3587–94.
22. Lee OR, Kim SJ, Kim HJ, Hong JK, Ryu SB, Lee SH, Ganguly A, Cho HT. Phospholipase A₂ is required for PIN-FORMED protein trafficking to the plasma membrane in the Arabidopsis root. *Plant Cell* 2010; 22: 1812–25.
23. Kim HJ, Ok SH, Bahn SC, Jang J, Oh SA, Park SK, Twell D, Ryu SB, Shin JS. Endoplasmic reticulum- and Golgi-localized phospholipase A₂ plays critical roles in Arabidopsis pollen development and germination. *Plant Cell* 2011; 23: 94–110.
24. Froidure S, Canonne J, Daniel X, Jauneau A, Briere C, Roby D, Rivas S. AtsPLA₂-α nuclear relocalization by the Arabidopsis transcription factor AtMYB30 leads to repression of the plant defense response. *Proc Natl Acad Sci USA* 2010; 107: 15281–6.
25. Ryu SB, Lee HY, Doelling JH, Palta JP. Characterization of a cDNA encoding Arabidopsis secretory phospholipase A₂-α, an enzyme that generates bioactive lysophospholipids and free fatty acids. *BBA – Mol Cell Biol L* 2005; 1736: 144–51.
26. Lee HY, Bahn SC, Kang Y-M, Lee KH, Kim HJ, Noh EK, Palta JP, Shin JS, Ryu SB. Secretory low molecular weight phospholipase A₂ plays important roles in cell elongation and shoot gravitropism in Arabidopsis. *Plant Cell* 2003; 15: 1990–2002.
27. Liao HL, Burns JK. Light controls phospholipase A₂-α and -β gene expression in *Citrus sinensis*. *J Exp Bot* 2010; 61: 2469–78.
28. Holk A, Rietz S, Zahn M, Quader H, Scherer GFE. Molecular identification of cytosolic, patatin-related phospholipases A from Arabidopsis with potential functions in plant signal transduction. *Plant Physiol* 2002; 130: 90–101.
29. Li M, Bahn SC, Fan C, Li J, Phan T, Ortiz M, Roth M, Welti R, Jaworski J, Wang X. Patatin-related phospholipase pPLA-IIIδ increases seed oil content with long chain fatty acids in Arabidopsis. *Plant Physiol* 2013; 162: 39–51.
30. Yang WY, Zheng Y, Bahn SC, Pan XQ, Li MY, Vu HS, Roth MR, Scheu B, Welti R, Hong YY, Wang XM. The patatin-containing phospholipase A pPLA-IIα modulates oxylipin formation and water loss in Arabidopsis thaliana. *Mol Plant* 2012; 5: 452–60.
31. Li MY, Bahn SC, Guo L, Musgrave W, Berg H, Welti R, Wang XM. Patatin-related phospholipase pPLA-IIIβ-induced changes in lipid metabolism alter cellulose content and cell elongation in Arabidopsis. *Plant Cell* 2011; 23: 1107–23.
32. La Camera S, Geoffroy P, Samaha H, Ndiaye A, Rahim G, Legrand M, Heitz T. A pathogen-inducible patatin-like lipid acyl hydrolase facilitates fungal and bacterial host colonization in Arabidopsis. *Plant J* 2005; 44: 810–25.
33. Noiriél A, Benveniste P, Banas A, Stymne S, Bouvier-Nave P. Expression in yeast of a novel phospholipase A₁ cDNA from Arabidopsis thaliana. *Eur J Biochem* 2004; 3752–64.
34. Shayman JA, Kelly R, Kollmeyer J, He Y, Abe A. Group XV phospholipase A₂, a lysosomal phospholipase A₂. *Prog Lipid Res* 2011; 50: 1–13.
35. Mansfeld J, Ulbrich-Hofmann R. Secretory phospholipase A₂-α from Arabidopsis thaliana: functional parameters and substrate preference. *Chem Phys Lipids* 2007; 150: 156–66.
36. Mariani ME, Villarreal MA, Cheung F, Leiva EPM, Madoery RR, Fidelio GD. In silico and in vitro characterization of phospholipase A₂ isoforms from soybean (*Glycine max*). *Biochimie* 2012; 94: 2608–19.
37. Fujikawa Y, Fujikawa R, Iijima N, Esaka M. Characterization of secretory phospholipase A₂ with phospholipase A₁ activity in tobacco, *Nicotiana tabacum* (L.). *Lipids* 2012; 47: 303–12.
38. Verlotto A, Liberatore MT, Cattivelli L, Trono D. Secretory phospholipases A₂ in durum wheat (*Triticum durum* Desf.): gene expression, enzymatic activity, and relation to drought stress adaptation. *Int J Mol Sci* 2013; 14: 5146–69.
39. Yang W, Devaiah SP, Pan X, Isaac G, Welti R, Wang X. AtPLAI is an acyl hydrolase involved in basal jasmonic acid production and Arabidopsis resistance to *Botrytis cinerea*. *J Biol Chem* 2007; 282: 18116–28.
40. Rietz S, Dermendjiev G, Oppermann E, Tafesse FG, Effendi Y, Holk A, Parker JE, Teige M, Scherer GF. Roles of Arabidopsis patatin-related phospholipases A in root development are related to auxin responses and phosphate deficiency. *Mol Plant* 2010; 3: 524–38.
41. Scherer GFE. Phospholipase A in plant signal transduction. *Lipid Signal Plants* 2010; 6: 3–22.
42. Dennis EA, Cao J, Hsu YH, Magriotti V, Kokotos G. Phospholipase A₂ enzymes: physical structure, biological function, disease implication, chemical inhibition, and therapeutic intervention. *Chem Rev* 2011; 111: 6130–85.
43. Hong YW, Wang TW, Hudak KA, Schade F, Froese CD, Thompson JE. An ethylene-induced cDNA encoding a lipase expressed at the onset of senescence. *Proc Natl Acad Sci USA* 2000; 97: 8717–22.
44. Kato T, Morita MT, Fukaki H, Yamauchi Y, Uehara M, Niihama M, Tasaka M. SGR2, a phospholipase-like protein, and ZIG/SGR4, a SNARE, are involved in the shoot gravitropism of Arabidopsis. *Plant Cell* 2002; 14: 33–46.
45. Scherer GFE. Secondary messengers and phospholipase A₂ in auxin signal transduction. *Plant Mol Biol* 2002; 49: 357–72.
46. Ackermann EJ, Kempner ES, Dennis EA. Ca²⁺-independent cytosolic phospholipase A₂ from macrophage-like P388D₁ cells – isolation and characterization. *J Biol Chem* 1994; 269: 9227–33.
47. La Camera S, Balague C, Gobel C, Geoffroy P, Legrand M, Feussner I, Roby D, Heitz T. The Arabidopsis patatin-like protein 2 (PLP2) plays an essential role in cell death execution and differentially affects biosynthesis of oxylipins and resistance to pathogens. *Mol Plant Microbe Interact* 2009; 22: 469–81.
48. Cacas JL, Vailliau F, Davoine C, Ennar N, Agnel JP, Tronchet M, Ponchet M, Blein JP, Roby D, Triantaphylides C, Montillet JL. The combined action of 9 lipoxygenase and galactolipase is sufficient to bring about programmed cell death during tobacco hypersensitive response. *Plant Cell and Environ* 2005; 28: 1367–78.
49. Ellinger D, Kubigsteltig II. Involvement of DAD1-like lipases in response to salt and osmotic stress in Arabidopsis thaliana. *Plant Signal Behav* 2010; 5: 1269–71.

Copyright of Biomolecular Concepts is the property of De Gruyter and its content may not be copied or emailed to multiple sites or posted to a listserv without the copyright holder's express written permission. However, users may print, download, or email articles for individual use.