

3395

NATIONAL LIBRARY

BIBLIOTHÈQUE NATIONALE

OTTAWA



OTTAWA

NAME OF AUTHOR.....JOHN...MANN.....
 TITLE OF THESIS.....THE ERYTHROCYTE A. ATP-ase SYSTEM.....

 UNIVERSITY.....UNIVERSITY OF ALBERTA.....
 DEGREE.....PH.D.....YEAR GRANTED.....1968.....

Permission is hereby granted to THE NATIONAL LIBRARY OF CANADA to microfilm this thesis and to lend or sell copies of the film.

The author reserves other publication rights, and neither the thesis nor extensive extracts from it may be printed or otherwise reproduced without the author's written permission.

(Signed).....*J. Mann*.....:

PERMANENT ADDRESS:

11, MIDDLETON PLACE,
 LOUGHBOROUGH.....
 LEICS.,.....
 ENGLAND.

DATED.....20th Feb.....1969

THE UNIVERSITY OF ALBERTA

SOME PROPERTIES OF THE MEMBRANE ATP-ASE SYSTEM
OF THE HUMAN ERYTHROCYTE

by



JOHN MANN

A THESIS

SUBMITTED TO THE FACULTY OF GRADUATE STUDIES
IN PARTIAL FULFILMENT OF THE REQUIREMENTS FOR THE DEGREE
OF DOCTOR OF PHILOSOPHY

DEPARTMENT OF BIOCHEMISTRY

EDMONTON, ALBERTA

July, 1968

UNIVERSITY OF ALBERTA
FACULTY OF GRADUATE STUDIES

The undersigned certify that they have read,
and recommend to the Faculty of Graduate Studies for
acceptance, a thesis entitled "Some Properties of the
Membrane ATP-ase System of the Human Erythrocyte",
submitted by John Mann in partial fulfilment of the
requirements for the degree of Doctor of Philosophy.

H.P. Collier

Supervisor

Edward Bell

Paul M. Henderson

G.R. Johnson

Robert T. Weed

External Examiner

Date 14th August, 1968

ABSTRACT

This investigation involves an attempt to correlate some properties of the membrane ATP-ase system of the human erythrocyte with present knowledge of the cation transport system of these cells.

The membranes (ghosts) were prepared by hypotonic haemolysis of the red cells, followed by repeated washing to remove haemoglobin and cytoplasmic constituents. The activity of the membrane consisted of two components: the first required the presence of Mg ions and was not inhibited by the cardiac glycosides (glycoside-insensitive ATP-ase); the second required the presence of both Na and K in addition to Mg and was completely inhibited by cardiac glycosides (glycoside-sensitive ATP-ase).

The interaction of the glycoside-sensitive ATP-ase of erythrocyte ghosts with Na and K was found not to obey Michaelis-Menten kinetics, but to be more adequately described by an allosteric effect of these ions, or by an alternative mechanism involving multiple binding sites for these ions consistent with recent kinetic data describing the active transport of these ions. There appeared to be no interaction between the cardiac glycoside ouabain and Na, but under conditions whereby the Na:K ratio was kept constant, a competitive inhibition of K activation by ouabain was observed. Unlike erythrocytes, erythrocyte ghosts do not appear to bind the glycosides with the same tenacity, probably due to some loss of necessary protein during their preparation. The effects of Mg and ATP upon the ATP-ase system appeared to

conform with Michaelis-Menten kinetics.

Like the active transport system, the ATP-ase system was inhibited by Ca only when this ion was located inside the cell membrane. Since both the ouabain-sensitive and ouabain-insensitive components of the ATP-ase system were inhibited by 'internal' Ca, it implies that there is no spatial asymmetry of the system.

The membrane p-nitrophenyl phosphatase was found to have many properties in common with the ATP-ase system, consistent with the phosphatase acting as part of the cation pump. Such similarities as Mg dependence and K activation, the latter being specifically inhibited by ouabain, were found. Both enzymes were inhibited by Ca and by NaF, and each enzyme showed a mutual inhibition by the substrate of the other. The most marked difference between the systems was in their pH optima. Despite the similarities, the phosphatase cannot definitely be concluded to be a component of the transport system.

Treatment of the ghosts with Triton X-100 yielded a soluble preparation containing cation-independent ATP-ase and p-nitrophenyl phosphatase activity but no cation-dependent activity. A soluble preparation was not obtained with other detergents and n-butanol, although all of these agents, and certain other organic reagents, had a common effect upon the properties of the ATP-ase system: namely, an activation of the ouabain-insensitive component prior to loss of activity. The results have suggested that an intact lipoprotein network is necessary for cation-dependent ATP-ase and cation pump activity.

An extension of the work with Ca to its effect upon the suppression of the osmotic haemolysis of erythrocytes indicates that this effect is probably due to a direct action of Ca upon the membrane, rather than through a selective loss of K from the cell of the type produced by Valinomycin.

ACKNOWLEDGEMENTS

The author wishes to express his sincere thanks to Professor H. B. Collier for his advice and direction during this work, to the Medical Research Council of Canada for their generous financial assistance, and to Mrs. Laura Randall for the typing of this thesis.

TABLE OF CONTENTS

	<u>Page</u>
ABSTRACT	ii
ACKNOWLEDGEMENTS.	v
LIST OF TABLES	vii
LIST OF ILLUSTRATIONS	x
LIST OF ABBREVIATIONS	xv
I. HISTORICAL INTRODUCTION	1
II. INTRODUCTION TO THE THESIS PROJECT.	18
III. METHODOLOGY	22
Enzyme Preparation and Assays	22
Accuracy and Validity of the ATP-ase Assay Methods	30
IV. RESULTS	39
Section I. Interaction of Erythrocyte Membrane ATP-ase with Na, K, Mg, ATP and Ouabain	46
Section II. The Effect of Calcium upon the ATP-ase Activity of Reconstituted Cells	71
The Effect of Calcium upon the Osmotic Haemolysis of Erythrocytes.	78
Section III. A comparison of Erythrocyte Membrane ATP-ase and Erythrocyte Membrane Phosphatase	91
Section IV. Solubilisation of Erythrocyte Membrane ATP-ase Activity. The Effect of Certain Detergents and Organic Reagents upon the Properties of the ATP-ase.	117
Section V. The Effect of Miscellaneous Inhibitors upon Erythrocyte Membrane ATP-ase Activity	129
V. DISCUSSION OF THE RESULTS	138
BIBLIOGRAPHY.	158

LIST OF TABLES

<u>Table</u>	<u>Page</u>
I. Comparison of Three Blank Systems	32
II. Recovery of Phosphate in the Presence of Solubilised Ghost Protein	32
III. Recovery of Phosphate in the Presence of ATP.	33
IV. Comparison of ATP-ase Activity Determined by the SLS-Method and the TCA-Method	35
V. Comparison of ATP-ase Activity Determined by the SLS-Method and the TCA-Method	35
VI. Comparison of the ATP-ase Activity Determined by Phosphate Estimation and by NADH Oxidation	36
VII. Variability of Several Parameters of the Ghost Preparation	42
VIII A. The Effect of 'Ageing' upon the ATP-ase Activity of Red Cell Ghosts	44
VIII B. The Effect of 'Ageing' upon the ATP-ase Activity of Red Cell Ghosts	44
IX. The Effect of Increasing the Tonicity upon the ATP-ase Activity of Red Cell Ghosts	47
X. The Effect of Potassium Concentration upon the Inhibition by Ouabain of the Glycoside-Sensitive ATP-ase Activity of Red Cell Ghosts	56
XI. The Effect of Sodium Concentration upon the Inhibition by Ouabain of the Glycoside-Sensitive ATP-ase Activity of Red Cell Ghosts	56
XII. The Effect of a High Sodium Concentration Relative to Potassium Concentration upon the Inhibition by Ouabain of the Glycoside-Sensitive ATP-ase of Red Cell Ghosts.	58
XIII. The Effect of Potassium upon the Binding of Ouabain to Red Cell Ghosts.	62
XIV. The Effect of the Time of Addition of Ouabain upon the Inhibition of Red Cell Ghost ATP-ase Activity.	64
XV. Km Values of ATP for Red Cell Ghost ATP-ase at Various Concentrations of Magnesium.	68

<u>Table</u>	<u>Page</u>
XVI. Km Values of Magnesium for Red Cell Ghost ATP-ase at Various Concentrations of ATP . . .	68
XVII. The Hydrolysis of ATP by Reconstituted Cells .	72
XVIII. The Effect of 'Internal' Calcium upon the ATP-ase Activity of Reconstituted Cells and Related Data	76
XIX. The Effect of 'External' Calcium upon the ATP-ase Activity of Reconstituted Cells. . . .	76
XX. The Effect of 'Internal' Calcium at Two Different Levels of Magnesium upon the ATP-ase Activity of Reconstituted Cells. . . .	79
XXI. The Effect of Different Calcium Concentrations and of Magnesium upon the Osmotic Haemolysis of Erythrocytes	83
XXII. The Effect of EDTA upon the Osmotic Haemolysis of Erythrocytes in the Presence of Calcium . .	83
XXIII. The Effect of Washing upon the Osmotic Haemolysis of Erythrocytes in the Presence and Absence of 0.8 mM Calcium	84
XXIV. The Effect of Calcium upon Various Parameters During the Osmotic Haemolysis of Erythrocytes.	87
XXV. The Effect of Valinomycin upon the Osmotic Haemolysis and Mean Cell Volume of Erythrocytes	89
XXVI. The Effect of Lowering the ATP Concentration Below the Magnesium Concentration upon the Inhibition of Red Cell Ghost ATP-ase Activity by 0.3 mM Sodium Fluoride.	103
XXVII. The Effect of Lowering the Magnesium Concentration Below the ATP Concentration upon the Inhibition of Red Cell Ghost ATP-ase Activity by 0.3 mM Sodium Fluoride.	103
XXVIII. The Effect of Added Phosphate upon the Amount of Inhibition by 0.3 mM Sodium Fluoride of Red Cell Ghost ATP-ase Activity.	104
XXIX. The Effect of Calcium upon the Amount of Inhibition Produced by 0.3 mM Sodium Fluoride of Red Cell Ghost ATP-ase Activity	104

<u>Table</u>	<u>Page</u>
XXX. The Effect of Magnesium Concentration upon the Inhibition of Red Cell Ghost Phosphatase Activity by Sodium Fluoride . . .	107
XXXI. The Effect of PNPP upon the ATP-ase Activity of Red Cell Ghosts	109
XXXII. The Effect of Heat in the Presence of Calcium upon the ATP-ase Activity of Red Cell Ghosts	114
XXXIII. The Effect of Prolonged Exposure of Red Cell Ghosts to SLS upon the ATP-ase Activity of the Ghosts.	122
XXXIV. Solubilisation of Ghost ATP-ase with Triton X-100.	124
XXXV. The Effect of Dialysis of Red Cell Ghosts upon their ATP-ase Activity	125
XXXVI. The Effect of the Length of Preincubation of Red Cell Ghosts with Ethacrynic Acid upon the ATP-ase Activity	132
XXXVII. The Effect of GSH upon the Inhibition of Red Cell Ghost ATP-ase Activity by o-phthaldialdehyde	133
XXXVIII. Irreversibility of the Inhibition by o-phthalidialdehyde of Red Cell Ghost ATP-ase Activity.	133
XXXIX. The Effect of Dimethyl Phthalate upon the ATP-ase Activity of Red Cell Ghosts	134

LIST OF ILLUSTRATIONS

<u>Figure</u>	<u>Page</u>
1. Diagrammatic Representation of the Molecular Model for a Sodium Pump Proposed by L.J. Opit and J.S. Charnock (46)	14
2. Diagrammatic Representation of the Allosteric Model for Membrane Pumps Proposed by O. Jardetzky (58).	16
3. The Effect of NADH Concentration upon the Absorbance of the Reaction Mixture	36
4. The Effect of Enzyme Concentration upon the Rate of Oxidation of NADH by Red Cell Membrane ATP-ase in the Coupled System.	37
5. The Effect of ADP upon the Absorbance of the ATP-ase Reaction Mixture Containing the PK-LDH System in the Presence of Triton X-100	37
6A.&B. The Time Course of Phosphate Liberation by (A) Red Cell Ghosts and (B) Reconstituted Cells	40
7. The Time Course of p-nitrophenol Liberation from p-nitrophenyl Phosphate by Red Cell Ghosts	41
8. The Effect of Enzyme Concentration upon the Rate of Liberation of p-nitrophenol from p-nitrophenol Phosphate by Red Cell Ghosts	41
9. The Effect of Sodium Concentration upon the Ouabain-Sensitive ATP-ase Activity of Red Cell Ghosts in the Presence of Low Ouabain Concentrations	48
10. A Double Reciprocal Plot of the Effect of Sodium Concentration upon the Ouabain-Sensitive ATP-ase Activity of Red Cell Ghosts in the Presence of Low Ouabain Concentrations	50
11. Hill Plots of the Ouabain-Sensitive ATP-ase Activity Expressed as a Function of Sodium Concentration.	50
12. The Effect of Sodium Concentration upon the Ouabain-Sensitive ATP-ase Activity of Red Cell Ghosts in the Presence of Low Ouabain Concentrations	52

<u>Figure</u>	<u>Page</u>
13. The Effect of Sodium Concentration at Various Potassium Concentrations upon the Ouabain-Sensitive ATP-ase Activity of Red Cell Ghosts	53
14. Hill Plots of the Ouabain-Sensitive ATP-ase Activity of Red Cell Ghosts as a Function of Sodium Concentration at Various Potassium Concentrations	53
15. The Effect of Potassium Concentration upon the Ouabain-Sensitive ATP-ase Activity of Red Cell Ghosts in the Presence of Low Ouabain Concentration.	54
16. A Double Reciprocal Plot of the Effect of Sodium Concentration upon the Ouabain-Sensitive ATP-ase Activity of Red Cell Ghosts at Low Ouabain Concentrations.	55
17. Hill Plots of Ouabain-Sensitive ATP-ase Activity as a Function of Potassium Concentration.	55
18. The Lineweaver-Burk Analysis of Ouabain Inhibition of the Ouabain-Sensitive ATP-ase Activity of Red Cell Ghosts in the Presence of a Constant Na:K Ratio of 7:1	59
19A. B.&C. The Effect of Magnesium Concentration upon the ATP-ase Activity of Red Cell Ghosts at Various ATP Concentrations	65
20A.B. C.&D. The Effect of ATP Concentration upon the ATP-ase Activity of Red Cell Ghosts at Various Mg Concentrations.	66
21. The Effect of Mg:ATP Ratio as a Function of ATP Concentration upon the Ouabain-Sensitive ATP-ase Activity of Red Cell Ghosts.	67
22. The Effect of ATP:Mg Ratio as a Function of Magnesium Concentration upon the Ouabain-Sensitive ATP-ase Activity of Red Cell Ghosts.	67
23. The Effect of ATP Concentration at Various pH Values upon the ATP-ase Activity of Red Cell Ghosts.	70
24. Progress Curve of Phosphate Formation and ATP Loss in Reconstituted Cells.	74
25. The Effect of 'Internal' Calcium upon the ATP-ase Activity of Reconstituted Ghosts	77

<u>Figure</u>	<u>Page</u>
26. The Effect of 'External' Calcium upon the ATP-ase Activity of Reconstituted Ghosts	77
27. The Effect of Calcium upon the Osmotic Haemolysis of Erythrocytes	82
28. The Effect of Calcium upon the Amount of Potassium Released from Red Cells at Various Stages of Haemolysis	88
29. The Effect of Calcium upon the Relationship between the Amount of Haemolysis and the Packed Volume of the Cell Suspension	88
30. The Effect of Washing upon the ATP-ase and Phosphatase Activity of Red Cell Ghosts.	92
31. The Effect of Washing upon the ATP-ase Activity of 'Intact' Red Cell Ghosts	93
32. The Effect of Magnesium Concentration upon the ATP-ase Activity of Red Cell Ghosts.	94
33. The Effect of Magnesium Concentration upon the Phosphatase Activity of Red Cell Ghosts.	94
34. The Effect of Potassium Concentration upon the ATP-ase Activity of Red Cell Ghosts.	96
35. The Effect of Potassium Concentration upon the Phosphatase Activity of Red Cell Ghosts.	96
36. The Effect of Sodium Concentration upon the ATP-ase Activity of Red Cell Ghosts.	97
37. The Effect of Sodium Concentration upon the Phosphatase Activity of Red Cell Ghosts.	97
38. The Effect of Ouabain upon the ATP-ase Activity of Red Cell Ghosts.	99
39. The Effect of Ouabain upon the Phosphatase Activity of Red Cell Ghosts.	99
40. The Effect of Calcium upon the ATP-ase Activity of Red Cell Ghosts	100
41. The Effect of Calcium upon the Phosphatase Activity of Red Cell Ghosts.	100
42. The Effect of Sodium Fluoride upon the ATP-ase Activity of Red Cell Ghosts.	102

<u>Figure</u>	<u>Page</u>
43. The Effect of Magnesium Concentration upon the Inhibition of Red Cell Ghost ATP-ase by Sodium Fluoride.	102
44. The Effect of Sodium Fluoride upon the Phosphatase Activity of Red Cell Ghosts.	106
45. The Effect of pH upon the ATP-ase Activity of Red Cell Ghosts	108
46. The Effect of pH upon the Phosphatase Activity of Red Cell Ghosts.	108
47. Inhibition of Red Cell Total ATP-ase Activity by p-nitrophenyl Phosphate	109
48. Inhibition of the Phosphatase Activity of Red Cell Ghosts by ATP	111
49. The Effect of Heat upon the ATP-ase and Phosphatase Activity of Red Cell Ghosts.	112
50. Arrhenius Plot for the ATP-ase Activity of Red Cell Membranes	115
51. Arrhenius Plot for the Phosphatase Activity of Red Cell Membranes.	116
52. The Effect of Tween 20 upon the ATP-ase Activity of Red Cell Ghosts.	118
53. The Effect of Triton X-100 upon the ATP-ase Activity of Red Cell Ghosts.	118
54. The Effect of Sodium Lauryl Sulphate upon the ATP-ase Activity of Red Cell Ghosts.	119
55. The Effect of n-butanol upon the ATP-ase Activity of Red Cell Ghosts.	119
56. The Effect of Calcium in the Presence of Sodium Lauryl Sulphate upon the ATP-ase Activity of Red Cell Ghosts.	120
57. The Effect of Urea upon the ATP-ase Activity of Red Cell Ghosts	126
58. The Effect of Dioxane upon the ATP-ase Activity of Red Cell Ghosts.	126
59. The Effect of Dimethyl Sulphoxide upon the ATP-ase Activity of Red Cell Ghosts.	128

<u>Figure</u>		<u>Page</u>
60.	The Effect of Ethylene Glycol upon the ATP-ase Activity of Red Cell Ghosts.	128
61.	The Effect of Ethacrynic Acid upon the ATP-ase Activity of Red Cell Ghosts.	131
62.	The Effect of o-phthaldialdehyde upon the ATP-ase Activity of Red Cell Ghosts.	131
63.	The Effect of Chlorpromazine upon the ATP-ase Activity of Red Cell Ghosts.	136

LIST OF ABBREVIATIONS

ADP	adenosine diphosphate
AMP	adenosine monophosphate
ATP	adenosine triphosphate
ATP-ase	adenosine triphosphatase (ATP phospho- hydrolase E.C. 3.6.1.4.)
Chol. Cl.	choline chloride
CoA	coenzyme A
CTP	cytidine triphosphate
DMSO	dimethyl sulphoxide
DNP	dinitrophenol
EDTA	ethylenediaminetetra-acetate
G-3-P	glyceraldehyde-3-phosphate
GSH	reduced glutathione
GTP	guanosine triphosphate
HEPES	N-2-hydroxyethylpiperazine-N'-2-ethane- sulphonic acid, pK = 7.55
ITP	inosine triphosphate
LDH	lactic dehydrogenase
MES	2(N-morpholine)ethanesulphonic acid - pK = 6.15
NAD	nicotinamide adenine dinucleotide
NADH	reduced nicotinamide adenine dinucleotide
OI-ATP-ase	ouabain-insensitive ATP-ase (glycoside- insensitive)
OS-ATP-ase	ouabain-sensitive ATP-ase (glycoside- sensitive)
PCMB	p-chloromercuribenzoate
PEP	phosphoenol pyruvate

3-PGA	3-phosphoglyceric acid
1-3-PGA	1,3-diphosphoglyceric acid
Phosphatase	p-nitrophenyl phosphatase
Pi	inorganic phosphate
PK	pyruvate kinase
PNP	p-nitrophenol
PNPP	p-nitrophenol phosphate
PDA	o-phthaldialdehyde
-SH	sulphydryl group
SLS	sodium lauryl sulphate
TES	N-tris(hydroxymethyl)-methyl-2-amino ethanesulphonic acid, pK = 7.5
TCA	trichloroacetic acid
TRIS	tris(hydroxymethyl)aminomethane, pK = 8.1
TX-100	Triton X-100
UTP	uridine triphosphate

I. HISTORICAL INTRODUCTION

It is now generally accepted that the human erythrocyte and probably most other cells contain an ATP-ase system concerned with maintaining the ionic composition of the cell by transporting Na ions out of and K ions into the cell.

The plasma, the natural environment of the red cell, contains a high concentration of Na relative to K, whereas within the cell these concentrations are almost reversed. Since small anions are able to diffuse freely across the cell membrane, the cell must be able to keep Na out in order to prevent the colloid osmotic pressure of haemoglobin anions inside the cell from producing haemolysis. This can be done by either having a membrane impermeable to Na and K or by having a permeable membrane in which the diffusion of these ions down their concentration gradients is offset by an opposite migration.

Prior to 1940 it was generally believed that the erythrocyte membrane was in fact impermeable to cations, and the anomalous distribution of Na and K ions inside the cell was thought to arise at some stage in the nucleated precursor and to be perpetuated by the impermeability of the membrane thereafter. Early evidence of an active transport of Na and K ions in erythrocytes stemmed from the observation that cells stored at 0°C lose K and gain Na. Upon rewarming the cells this loss was reversed, K passing back into the cells accompanied by an extrusion of Na. Removal of glucose or inhibition of glycolysis prevented this reversal. Indeed,

addition of glycolytic inhibitors to cells maintained at 37°C, or removal of glucose, produces a loss of K in these cells, a similar situation to that of cells stored at 0°C (1,2).

The rate of entry of K into cold-stored cells rises sharply as the K concentration in the external medium is increased to about 10 mM, after which the influx increases more slowly and linearly with the external K concentrations. The two components of this curve could be described by the sum of a Michaelis-Menten adsorption mechanism plus a linear influx. The Michaelis component which describes the active movement of K ions into the cell is markedly lowered by the absence of glucose. The linear influx of K, independent of glucose, would be a downhill movement of K. Similarly, the Na efflux was divisible into two components: an active efflux dependent upon the presence of glucose and significantly upon the presence of K outside the cell membrane; and a passive movement independent of an energy supply (4, 5). The dependence of Na extrusion upon external K supports the hypothesis that the two ions are probably transported by a common carrier type of mechanism.

The observation that cardiac glycosides specifically inhibit active cation fluxes in erythrocytes has greatly facilitated the investigation of active transport (6,7). The glycosides have little or no effect upon the passive movement of Na and K or upon the energy production within

the cell. A direct action of these compounds upon the transport mechanism rather than upon the energy supply was supported by the observation that raising the concentration of K outside the cells overcomes to some extent the inhibition of active transport produced by the glycosides.

Speculation that the active movement of Na and K was accomplished at the expense of high-energy phosphate bonds was soon confirmed. A parallel decline of ATP and K in cells poisoned with iodoacetate, and a concomitant rise of ATP and K during the re-warming of cold-stored cells in the presence of glucose was observed (8). More direct evidence came from experiments in which the reversal of haemolysis technique was used. This method allows the introduction of non-penetrating substances into the erythrocyte by haemolysing the cells in a hypotonic solution containing the substance to be introduced. Upon restoring the medium to isotonic conditions the cell "re-seals" itself and still behaves like a normal cell with respect to cation movements, provided suitable substrates are present within the cell membrane. Cells into which ATP was introduced were now able to actively transport Na and K even though they were no longer capable of glycolysis (9,10). The other nucleotide triphosphates, CTP, UTP, GTP and ITP could not support active transport in this way (11). Thus ATP would appear to be the energy

source of the cation pump in erythrocytes.

The discovery of active transport led inevitably to the search for an enzyme in the red cell membrane which could hydrolyse ATP. The early investigations (12,13,14) did indeed show that the membrane contained an ATP-ase, but at that time the activity of the enzyme could not be correlated with the active transport of Na and K. After it was found that homogenates of crab nerve tissue contained an ATP-ase which, significantly, was stimulated by the presence of Na and K and inhibited by the cardiac glycosides (15), further investigation of erythrocyte ATP-ase took place.

The membranes used in these investigations were prepared by hypotonic haemolysis of the red cells, followed by repeated washing of the membrane to remove haemoglobin and cytoplasmic constituents. The ATP-ase activity of the membrane was found to consist of two components (16,17): the first component required the presence of Mg ions and was not inhibited by cardiac glycosides; the second component required the presence of both Na and K in addition to Mg ions, and was completely inhibited by cardiac glycosides at concentrations comparable to those which inhibit active transport. The enzyme system was entirely dependent upon the presence of Mg as had been found previously for active transport. Calcium ions could not replace Mg, but in the presence of Mg they exerted a dual action: an

activation of the glycoside-insensitive fraction at low concentrations (0.001-0.5 mM) followed by an inhibition at higher concentrations, and an inhibition of the glycoside-sensitive component (glycoside-inhibitable) at all concentrations (17). The dependence of Ca-inhibition upon the Mg:Ca ratio suggests that it may be due to a Mg-Ca competition. This was later shown to be classical competitive inhibition between Mg:ATP and Ca:ATP, assuming a 1:1 complex of Mg:ATP to be the substrate of the enzyme (18). The 1:1 ratio was based on the observation that maximum activity was obtained when Mg and ATP were in this ratio (39).

When the concentration of Na or K, at any fixed concentration of the other ion, required to produce half-maximal activation of the transport system was compared to the concentration required to produce half-maximal activation of the ATP-ase, they were found to be almost identical (16,17). The actual optimal concentration of the alkali metal ions was found to depend upon the Na:K ratio rather than upon the concentration of each individual ion. An excess of either Na or K produced an inhibition, perhaps due to replacement of one ion by the other at its active site. There is evidence for this hypothesis in the crab nerve system (19). Furthermore the inhibitory effects of low concentrations of cardiac glycosides upon ATP-ase activity could be overcome by raising the K-concentration (17).

ATP was the nucleotide triphosphate most readily hydrolysed by the membrane enzyme. ITP was utilised at about 10% the rate of ATP, whilst GTP and UTP were not hydrolysed at all (20). ADP is hydrolysed at about half the rate of ATP (16). The phosphomonoester, p-nitrophenyl phosphate, is also hydrolysed by the membrane. The fact that this Mg-dependent reaction is activated by K and inhibited by high concentrations of cardiac glycosides has led to speculation that it might be part of the ATP-ase system (21,22).

Excellent correlation was obtained when the structure-activity relationship of the cardiac glycosides upon the active transport and upon the ATP-ase were examined (16,17). Both systems showed numerous parallels including: the more pronounced activity of the glycosides as compared to their genins; the dependence upon the unsaturated lactone ring and on its position (weaker action of allo compounds); the quantitatively weaker, but qualitatively digitalis-like action of simple lactones not possessing a steroid nucleus; the weakening action of epimerisation at C₃; and in the order of potency of the various glycosides, genins and lactones.

The metabolic inhibitors azide, acetate, DNP, cyanide and iodine, which do not inhibit the active transport of Na and K, had no effect upon the ATP-ase (20). The enzyme is however inhibited by sulphhydryl blocking agents (23). Those

reagents which react only with the most readily available -SH groups such as NEM and IAA do not inhibit the enzyme, whilst the more powerful inhibitors chloromerodrin and HgCl_2 block the transport ATP-ase only after 10-20% of the total -SH groups have been inhibited (23).

Further evidence for the involvement of the membrane ATP-ase in the transport of Na and K has been obtained by studying the erythrocytes from different species. For example, two distinct species of sheep exist; one species having erythrocytes with a high internal K concentration (HK cells), and the other species a low internal concentration of K in their erythrocytes (LK cells) (24). The ATP-ase of the HK cells was found to be about four times as active as that of the LK cells, the same ratio that had previously been found for the transport of K in these cells.

The relationship between the two components of the ATP-ase, the glycoside-sensitive and the glycoside-insensitive component is still not clear. It has been suggested that they may be either two distinct enzymes (20) or two forms of the same enzyme in which the glycoside-insensitive component may be glycoside-sensitive material which has become desensitised to Na and K during the course of preparation. The K_m of ATP, which is similar for both components, favours the existence of one binding site for ATP and thus one enzyme (24). However, the decrease in the glycoside-sensitive:glycoside-insensitive ratio during the course of

'ageing' suggests a loss of sensitivity to Na and K (17). The ratio of the two components also depends upon the method of preparation (16,17,25), but rarely occurs in a ratio greater than 7:3 for sensitive:insensitive material. Recently some success has been reported in separating those components by NaI extraction (26) and by ultrasonication (27). This may perhaps indicate the existence of two separate enzymes.

"In vivo" the two sides of the red cell membranes are bathed by solutions differing markedly in their cation composition. The external surface of the membrane is surrounded by a fluid rich in Na from which K ions are pumped into the cell, and the internal surface of the membrane by a fluid rich in K ions from which Na ions are pumped out of the cell. If the membrane ATP-ase is responsible for the active transport of Na and K it must therefore be stimulated by Na ions on the inside of the membrane and by K ions at the external surface. In order to test this hypothesis cells containing ATP and varying amounts of Na and K were prepared by the reversal of haemolysis technique (28,29). By suspending them in suitable media both internal and external concentrations of cation were readily controlled.

The rate of ATP hydrolysis within the cell was found to be dependent upon the internal Na concentration, rising to a maximum rate as the Na concentration was increased to 100

m.mole/litre cells. This Na-dependent ATP hydrolysis only occurred, however, if K was present in the external medium. Both the external Na concentration, and as far as could be determined, the internal K concentration, had no effect upon the rate of hydrolysis of ATP. Thus it appears that the membrane ATP-ase is controlled by the internal concentration of Na and the external concentration of K, the location from which these ions are actively transported. External K could be replaced by other alkali metal cations in the following increasing order of effectiveness, Li, Rb and Cs. Since the cardiac glycosides are competitive to some extent with K ions, it seems likely therefore that these drugs act also at the external surface of the membrane. This has in fact been established only in the case of the squid axon (30).

The exact number of Na and K ions actively transported across the membrane for each mole of ATP hydrolysed is still a matter of some controversy. The ratio of Na:K transported has variously been reported as 2:1 (31), 3:2 (32,33), whilst evidence for a 1:1 ratio has also been presented (34). A Na:ATP ratio of 3:1 has been established under a variety of cation gradients; i.e. whether Na is pumped 'uphill', 'on the level', or 'downhill' (37,41). Most recent evidence also suggests that the K:ATP ratio is nearer 2 than 3 (36,37,41). When the recently discovered phenomenon of K-K exchange across the membrane was taken into account, a value of 1.8:1 was obtained for the Na:K ratio (35). Despite the variations cited, most evidence would suggest that fewer K ions are

taken up by the cell than Na ions expelled.

It has been calculated that approximately 30% of the ATP produced in erythrocytes may be devoted to the active transport of Na and K ions (38). Since the pump can use such significant quantities of ATP, it is reasonable to assume that the pump may exert some control over the energy production of the cell. In respiring slices of kidney, brain or liver, inhibition of active transport by cardiac glycosides results in a decreased oxygen uptake by the tissue (39,40). In erythrocytes, it has been found that the lactate production shows the same dependency upon the presence of K ions and upon the amount of internal Na as does the transport system and the ATP-ase (41). There is evidence that phosphoglycerate kinase may be the key enzyme through which the pump can control energy production within the cell (41). The membrane ATP-ase is envisaged as producing a compartmentalised form of ADP which specifically reacts with phosphoglycerate kinase, also present as part of the membrane. When linked to triosephosphate dehydrogenase, another membrane bound enzyme, the system would constitute an ATP generating system for the pump according to the following scheme:

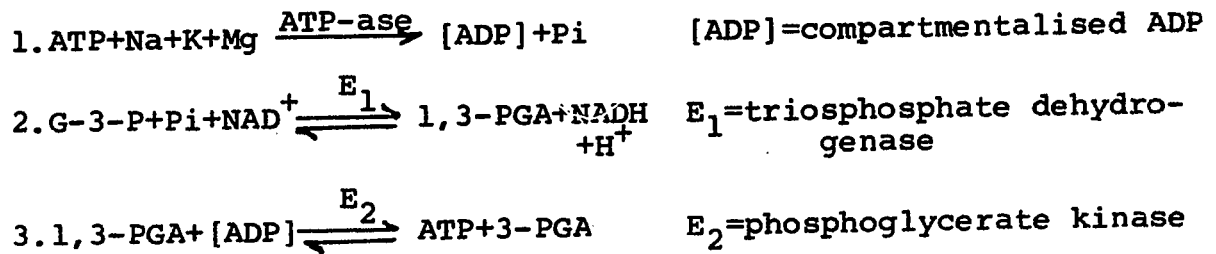

The molecular mechanism by which the hydrolysis of ATP results in the active transport of Na and K ions is still obscure. Several hypothetical mechanisms have been suggested, most of which postulate a two-stage reaction. The initial step might be a Na-dependent phosphorylation of an acceptor molecule, possibly the enzyme itself, followed by a K-dependent dephosphorylation (3,4,43,44,45,46). Two of the models for a cation pump will be considered in more detail later in this section.

Attempts to identify a phosphorylated intermediate concerned with the active transport of Na and K in the erythrocyte have so far been unsuccessful. Labelling of membrane protein with ^{32}P during the hydrolysis of AT^{32}P does occur. The labelling is Mg-dependent, enhanced by Na, and inhibited by Ca, but no turnover of this label has yet been demonstrated (47). The relatively low activity of erythrocyte ATP-ase may account for these difficulties. More success has been obtained using ATP-ase preparations from kidney cortex or brain microsomal tissue, which have similar properties to erythrocyte membrane ATP-ase. With these preparations, it was found that transfer of the terminal phosphate of AT^{32}P to a protein component of the preparation was enhanced by the presence of Na ions, and that upon the subsequent addition of K ions, a reduction in the amount of labelling occurred. No enhancement of labelling occurred with K alone. The cardiac glycoside ouabain reduced the dephosphorylation of the labelled protein produced by the addition of K, but also inhibited to some extent the Na-dependent labelling (48,49).

Accumulating evidence indicates that phosphorylation of the protein involves the formation of a high-energy acyl phosphate (49,50). Evidence for this suggestion is based upon the observation that inorganic phosphate is formed upon treatment of the phosphorylated protein with alkali or hydroxylamine. Some doubt has been raised as to whether the intermediate of the transport ATP-ase can be an acyl phosphate because of the inability of hydroxylamine even at high concentration to inhibit the enzyme (51,52). However, it now appears that hydroxylamine will inhibit the ATP-ase, but only if small amounts of Ca ($10^{-8}M - 10^{-5}M$) are also present (53). Recently the phosphorylated moiety in brain tissue has been identified as a γ -carboxyl group of a glutamic acid residue (49).

Although it is now generally accepted that the Na-K activated ATP-ase present in many cell membranes is intimately connected with the translocation of Na and K across the cell membrane, the actual means by which this is accomplished still remains a matter of speculation.

Many schemes which have been proposed to conform with the present knowledge of the ATP-ase reaction involve a two-stage mechanism of the type proposed by Post and co-workers (54,55).

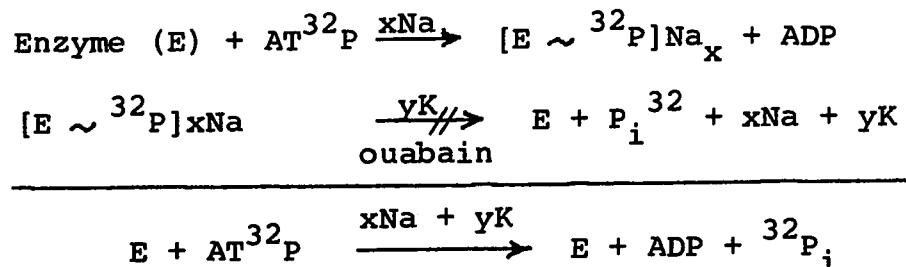

The nature of the phosphorylated complex seems to be protein (48,49,50) and not lipid (56,57) as has previously been suggested. Although the above scheme shows phosphorylation of the enzyme, the phosphorylated complex may be a non-enzymatic carrier. The fundamental question as to whether the ATP-ase is at the same time both the 'engine' and the transport system or whether they are separate entities, remains unanswered. Thus the translocation of Na and K may be accomplished by rotation of a single enzyme or conformational changes occurring in the enzyme during the course of its catalytic activity, or by a system containing a transphosphorylating enzyme or enzymes and a phosphatase. The catalytic activity of the latter system might be associated with the synthesis and breakdown of a non-enzymatic Na-K carrier which traverses the membrane by diffusion. Thus far, however, no chemical compound has been described which would have the properties of a carrier required to transport Na and K.

Two interesting models for membrane pumps have been described recently. Opit (46) has proposed a molecular mechanism consistent with the Danielli-Davson membrane model, the inner protein layer of which would contain the ATP-ase (Fig. 1A). The inner protein is visualised as a highly ordered, polarizable chain with many surface-oriented cationic and anionic groups, among which a smaller number of amino acid residues would constitute the active centre of the enzyme. Initially the amount of Na and K bound to the cationic sites would merely depend upon the concentration of each species

Fig. 1. Diagrammatic Representation of the Molecular Model for a Na Pump Proposed by L.J.Opit and J.S.Charnock (46)

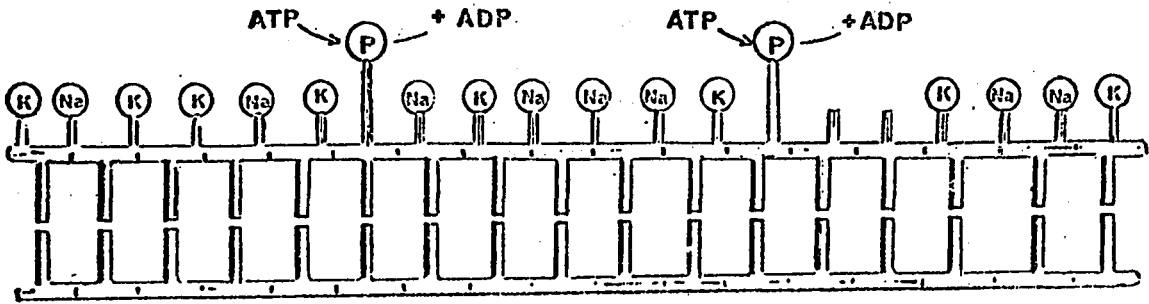

A - Representation of a unit segment of membrane showing the associated pairs of Na and K with the anionic sites and phosphorylation of the active site.

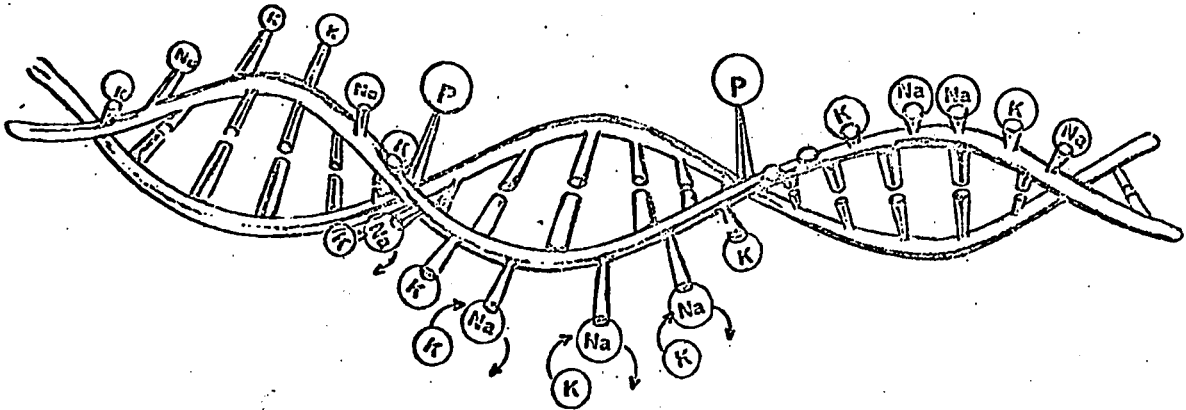

B - Representation of the rotation of the protein layers with exchange of K for Na.

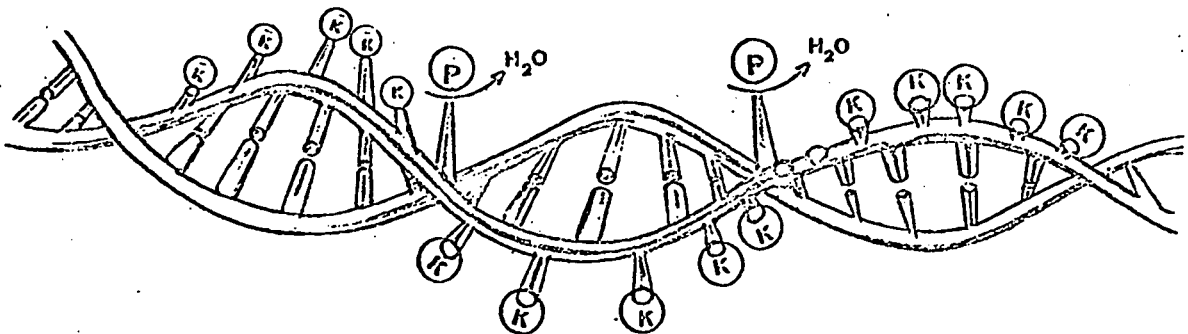

C - Representation of the attack on the phosphorylated centre following the K for Na exchange.

present. To operate the pump, a sufficient number of Na ions must be bound to cause a redistribution of electron density along the macromolecule and formation of the phosphorylated intermediate at the active site. Formation of the intermediate induces a further change in electron density along the protein chain producing an elongation of the inner protein layer and a rotation of these molecules about the central lipid core of the membrane, thus exposing the Na-bound sites to the outside (Fig. 1B). Because of the phosphorylation and conformational changes of the protein, a preference for K at the cation sites is now displayed and Na exchanges for K extracellularly. Adsorption of K at the cation sites causes a further redistribution in the electron density rendering the phosphorylated sites susceptible to hydrolysis (Fig. 1C) which in turn allows the protein to return to its original conformation, thereby transporting K ions to the inside of the cell where they can be exchanged for Na.

An alternative allosteric model in which a polymer molecule acts as the pump has been proposed by Jardetzky (58) (Fig. 2). The macromolecule would contain a cavity in the interior of the molecule large enough to admit a small molecule like Na or K, and be able to assume two different configurations such that the cavity is open to one side of the membrane in one configuration and open to the other in the alternative configuration. Na ions would bind to specific binding sites in the cavity when it is exposed to the interior of the cell, triggering a phosphorylation of the pump at

Fig.2. Diagrammatic Representation of the Allosteric Model for Membrane Pumps Proposed by O. Jardetzky (58)

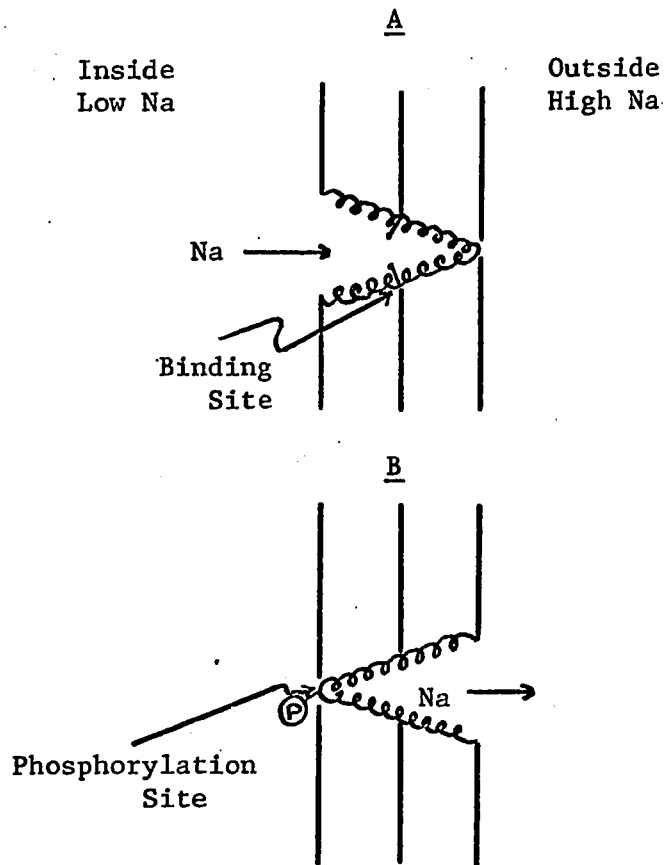

Longitudinal section of the allosteric pump. A, Na-form, B, K-form.

either a nearby or distant site, resulting in the allosteric rearrangement in which the cavity is now exposed to the outside. As a result of the rearrangement, the affinity of the binding site for Na is now lowered, and since the volume of the molecular compartment is small, the Na concentration in it is in effect greater than in the surrounding medium, thus allowing Na to diffuse out of the cavity. Replacement of Na by K in the cavity would trigger dephosphorylation and rearrangement of the macromolecule to expose the cavity to the inside of the cell. Jardetzky suggests that changes of 2-3Å in the positions of the polypeptide chains of the macromolecule would be sufficient for such a mechanism, changes of such magnitude having been observed during oxygen binding to haemoglobin. This type of mechanism could be accomplished by either the enzyme itself acting as the pump or perhaps by an independent macromolecule phosphorylated and dephosphorylated by the kinase-phosphatase system.

These types of models account for the principal experimental findings, provide an explanation for the vectorial nature of ion movements, and are adaptable to the kinetic data which suggest several binding sites, perhaps with different binding constants, for both Na and K. Whether or not Na and K bind to the same sites in a shuttle type of service in which sites from which Na ions leave are then occupied by K and vice versa, or whether each ion has its own specific binding site, is not yet clear.

II. INTRODUCTION TO THE THESIS PROJECT

The work in this thesis was undertaken to try to obtain more information about erythrocyte membrane ATP-ase activity which might be correlated with existing knowledge of the active movement of Na and K across the cell membrane in the hope that it might lead to a better understanding of this mechanism.

Although previous observations suggested that the interaction of Na and K with the red cell membrane ATP-ase, and the relationship of active K influx and active Na efflux to the external K concentration in whole cells, could be adequately described by Michaelis-Menten kinetics, recent evidence indicates that the situation may be more complex. From his analysis of the interaction of Na, K, Mg, and ATP with rat brain ATP-ase, whose properties are very similar to those of the red cell enzyme, Squires (59) has suggested the existence of two or more cooperatively interacting binding sites for each of these ligands. Ahmed (60), however, found that the interaction of Na and K with the brain enzyme follows Michaelis-Menten kinetics but that two Na ions are involved in the activation of the enzyme. In rat red cells, a plot of Na efflux against external K concentration, found by Hoffman (61) to be sigmoidal, is inconsistent with the Michaelis-Menten model. More detailed investigations by Sachs (62,63) and by Glynn (64) have led to the suggestion that the relationship between active K efflux and the external K concentration

can more adequately be described by a model in which two K ions are required simultaneously at some site or sites in the transport system before transport occurs. We have reinvestigated the interaction of Na, K, Mg, and ATP with erythrocyte ATP-ase and have tried to relate these findings to the existing proposals for the active movement of Na and K.

The relationship between the activation by Na and K of the ATP-ase and its inhibition by the cardiac glycoside ouabain was also investigated, since a better understanding of the mode of action of the glycosides should lead to more information regarding the mechanism of active transport. Although the inhibition of both the cation pump and the ATP-ase activity of the erythrocyte by cardiac glycosides, which can be relieved by raising the K concentration, is suggestive of some competition between the glycosides and K, this cannot be clearly defined by Michaelis-Menten kinetics. Hoffman has suggested that the glycosides are allosteric inhibitors of active transport in the sense that they do not bind at the K transport site but at a site in its neighborhood where they alter conformation of the active site, thereby inhibiting the pump (65). Matsui (66) has reported that the glycosides are non-competitive inhibitors of K activation whilst Ahmed (60) believes that inhibition of the ATP-ase in brain is a result of a competition between the glycoside and both Na and K. Schatzmann (67) reports that ouabain can enhance the inhibition of K activation by Na.

As in the case of the cardiac glycosides, both the pump and ATP-ase activity are inhibited by Ca, but only in regard to the pump has the location of action been established. We have investigated therefore, the site of action of Ca upon ATP-ase activities. This should also help to confirm the location of the ATP-ase system, and since Ca has an effect upon both components of the ATP-ase, help to resolve the question as to whether or not these components are spatially asymmetric. The experimental work with Ca was extended to its effects upon the osmotic haemolysis of erythrocytes. This stemmed from the observation that during the preparation of reconstituted cells for experiments designed to locate the site of action of Ca upon the ATP-ase, red cells appeared more resistant to haemolysis in the presence of Ca than in its absence.

In view of the widely held belief that the cation transport mechanism might consist of at least two steps: a Na-dependent kinase reaction followed by a K-dependent phosphatase reaction, interest has therefore focussed upon reports of a K-dependent p-nitrophenyl phosphatase occurring in the membrane of several tissues, apparently in conjunction with ATP-ase activity (21,22,68,69). An examination of the subcellular distribution of the two activities in rat brain has suggested, however, that the two activities could not be attributed to a single enzyme (70). A comparison of p-nitrophenyl phosphatase activity and ATP-ase activity of erythrocyte membranes was therefore undertaken to see whether the

properties of the K-dependent phosphatase are compatible with its suggested function as a component of a system responsible for the active movement of Na and K across the cell membrane.

Some attempts were also made to obtain a soluble preparation of membrane ATP-ase activity with certain detergents and n-butanol. The effects of these agents, and certain other organic reagents which alter protein conformation, upon the properties of the ATP-ase system were also investigated. The effects upon ATP-ase activity of a few compounds containing certain structural features in common with the cardiac glycosides: viz. a carbonyl oxygen in conjunction with a carbon-carbon double bond, were also investigated.

III. METHODOLOGY

Enzyme Preparations and Assays

1. Preparation of erythrocyte membranes (ghosts)

The ghosts were prepared by the method of Weed (71, 72). The following buffers were prepared and used where stated during the ghost preparation.

Buffer No.1 30 mOsm pH 7.4 - 1000 mls	Buffer No.2 60 mOsm pH 7.4 - 1000 mls	Buffer No.3 30 mOsm pH 7.4 - 1000 mls
Na ₂ HPO ₄ 1.16 g	NaCl 1.26 g	NaCl 0.63 g
KH ₂ PO ₄ 0.51 g	Tris 1.16 g	Tris 0.58 g
Na ₂ EDTA 372 mg	Na ₂ EDTA 372 mg	Na ₂ EDTA 372 mg

Human blood samples containing EDTA as an anticoagulant were obtained from the haematology laboratory at the University of Alberta Hospital and pooled. After centrifuging the blood at 100 × g for 10 minutes, the plasma and white cells were aspirated and the remaining erythrocytes washed three times with 1% NaCl solution. The cells were then diluted with 1% NaCl to produce a 25% haematocrit value. One volume of this suspension was mixed with seven volumes of No. 1 buffer and allowed to haemolyse for twenty minutes. The haemolysate was then centrifuged at 9000 × g for 10 minutes. The supernatant was removed and the sedimented membranes washed and re-centrifuged once in No. 2 buffer, twice in No. 3 buffer, and finally suspended in No. 2 buffer. At this stage, the ghosts were virtually free of haemoglobin. Ghosts

prepared in this way appear as biconcave discs when viewed under phase-contrast microscopy, even though they no longer have their characteristic low permeability to cations and are now freely permeable to ATP.

If Na-free ghosts were required, the final wash in No. 2 buffer was omitted and the membranes were washed instead two times with a weak buffer (4.5 mM TES adjusted to pH 7.4 with Tris). These ghosts were now fragmented. The fragmentation appears to be a function of the tonicity and occurs when the osmolarity of the suspending fluid is reduced below a critical value of approximately 20 mOsm. As far as can be determined, however, the properties of the ATP-ase in both intact and fragmented cells were the same.

2. Preparation of ghosts by the reversal of haemolysis technique

When ghosts which retained their low permeability to cations and impermeability to ATP were required, the following technique was used (28).

One volume of washed erythrocytes was rapidly haemolysed by mixing them with five volumes of Mg-ATP solution (either 2.0 or 4.0 mM of each). After three minutes, the haemolysate was restored to isotonicity by the addition of 3 M NaCl and the cells were incubated at 37°C for 30 minutes, during which time the cells regained their original low permeability to cations. The suspension was then centrifuged at 2000 rpm and the cells were washed once in the medium in which they were to be incubated during the ATP-ase assay. After the preliminary incubation, little or no haemoglobin

was present in the supernatant at the end of the 30 minute assay. Cells prepared in this way retained approximately 25% of their original haemoglobin.

3. Quantitation of the ghosts

After preparation, the ghosts could be quantitated with a Coulter Model B electronic particle counter with a 50 μ aperture. For counting, a lower threshold of 4 and an upper threshold of 50 (12 - 150 μ^3) was used, the aperture current set at 1/APC = 2 and the amplitude at 1/AMP = 1. The gain trim was set at 50. A 1 in 25,000 dilution of the ghost suspension in 1% saline was used for counting. Counts in the range of 10,000 - 90,000 were usually obtained with this dilution, and after correcting for coincidence, the estimate was expressed as number of ghosts per ml of suspension. This value was of the order of 1 to 5 x 10⁹ cells per ml.

The protein content of the ghosts was estimated by the biuret method of Reinhold (73). The procedure was slightly modified by including 0.9% SLS in the sample to solubilise the ghosts. Bovine serum albumin was used as standard. Values of the order of 10⁻⁹ mgm protein per cell were obtained.

Cell haemoglobin was not routinely determined since the haemoglobin constituted less than 1% of the total cell protein. When necessary, however, the method of van Kampen (74) was used.

4. Determination of the ATP content of reconstituted cells

The ATP content of the reconstituted cells was

5. Preparation of Tris-ATP

The disodium salt was used routinely but when Na-free solutions were required, the Tris salt was prepared as follows (76). Two 5G portions of the cation exchange resin BioRad AG50w-X-8, 200-400 mesh, were washed twice with four volumes of 0.1 N HCl followed by two washings with deionised water. 1G Na₂ ATP was dissolved in 15 mls of water, stirred with the first portion of the resin for 7 minutes at 0°C, after which the suspension was filtered. The filtrate was then stirred with the second portion of the resin for a further seven minutes at 0°C and the suspension filtered into 0.5 ml saturated Tris solution. The pH of the solution was adjusted to 7.4 with more Tris and the concentration of ATP determined by absorbancy measurements at 259 mμ.

6. Reagents

The salts used were of analytical reagent grade. All reagents were made up in deionised water.

7. General method of ATP-ase assay

The ATP-ase activity of the ghosts was assayed routinely by suspending an aliquot of the ghost suspension in a reaction mixture of total volume 2.6 - 3.0 ml containing the following components.

NaCl	100-120 mM
KCl	12-16 mM
MgCl ₂	2-3 mM
ATP	2.0 mM
Buffer	Tris or TES 30 mM pH 7.4 (when Tris was used, the solution was adjusted to pH 7.4 with HCl, when TES was used, the solution was adjusted to pH 7.4 with Tris)

Ghost suspension	0.5 ml
Ouabain where necessary	10^{-4} - 5×10^{-4} M

The composition could be varied to suit the need of the individual experiment.

The ATP-ase activity was obtained by measuring the formation of phosphate or ADP by the ghost suspension.

8. Assay of phosphate in the reaction mixture

The ATP-ase reaction was generally started by adding ATP in a volume of fluid equal to 1/30th or 1/15th of the total volume of the reaction mixture so that the cooling effect was small. The ATP was added serially at 10 second intervals and the tubes were incubated usually for 60 mins at 37^o, at the end of which time the tubes were removed from the water bath to iced water at 10 sec intervals. They were allowed to cool in ice for 1 min and then ice-cold TCA (30% w/v) was added to make the final concentration 5%. The tubes were kept in ice until it was convenient to centrifuge down the precipitated protein and estimate the inorganic phosphate in an aliquot of the supernatant by the method of Fiske and SubbaRow (77). Cooling was necessary to obtain complete deproteinization and avoid turbidity upon the addition of acid molybdate. The time between the addition of acid molybdate and reducing agent, and reading the optical density was the same for all tubes so that the small amount of acid hydrolysis of ATP was kept constant for each tube (a Beckman DU Spectrophotometer equipped with a Gilford Model 220 Absorbance Indicator was used for all absorbance measurements in

1 cm cuvettes). This method is referred to as the TCA-Method.

An alternative procedure which avoided the need for cooling and deproteinization was later adopted. At the end of the incubation period, 0.5 ml of 7% SLS was added to the reaction mixture (2.6 or 3.0 ml vol), immediately stopping the reaction and producing a clear solution. The inorganic phosphate was then measured directly upon this solution as above, the SLS preventing any precipitation of the protein by the reagents involved. This method is referred to as the SLS-Method.

9. Assay of ADP in the reaction mixture

The ADP was measured by coupling the hydrolysis of ATP to pyruvate kinase and lactate dehydrogenase according to the following scheme.

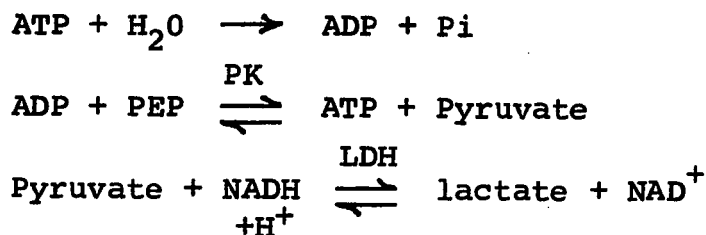

In addition to the cations required for the ATP-ase system, 10 μg pyruvate kinase (Boehringer Mannheim Corp., New York - 125 units/mg), 12.5 μg lactate dehydrogenase (Boehringer Mannheim Corp., New York - 360 units/mg), 0.7 μmole NADH and 2.4 μmole PEP were added to the 3 ml reaction mixture. The linear rate of oxidation of NADH was recorded at 340 $\text{m}\mu$ giving a direct measure of ATP-ase activity. This method was particularly suitable when low ATP concentrations

were used since the initial velocity is obtained. The phosphate method is not sensitive enough to give initial velocities at low ATP concentrations.

When low Mg concentrations were present in the reaction mixture, a slightly different method was used since these Mg concentrations were too low to allow the PK-LDH system to rephosphorylate ADP at the same rate as it was produced. The tubes were incubated in the absence of the PK-LDH system for a short time (less than 20% ATP hydrolyzed) after which the reaction was stopped and the protein solubilized by adding 0.4 ml of 10% TX-100. To each tube was added 10 μ g PK, 12.5 μ g LDH, 0.7 μ mole NADH, 30 μ mole $MgCl_2$, and the decrease in absorbance at 340 m μ upon the addition of 2.4 μ mole PEP was taken as a measure of the ADP produced. Although the TX-100 completely inhibited the ATP-ase activity, the PK-LDH system was still active.

10. Assay of p-nitrophenol in the reaction mixture

The phosphatase activity of the membrane was measured under conditions similar to the ATP-ase assay by suspending the ghosts in a reaction mixture of total volume 3.0 mls containing the desired cations, etc. The composition of the reaction mixture was varied to conform with the demands of the particular experiment. Para-nitrophenyl phosphate was used routinely as the substrate of the phosphatase, the reaction being started by its addition in a small volume to the reaction mixture. Although the disodium salt was generally used, when required the Tris salt was prepared in exactly the

same way as was Tris-ATP.. The absorbance at 310 m μ was a measure of the concentration of the Tris-para-nitrophenyl phosphate. Carbamyl and acetyl phosphates were also tried as substrates but the low activity of the phosphatase combined with the lability of these compounds in acid molybdate made them unsuitable for routine use.

The phosphatase activity was determined by measuring the para-nitrophenol released. The reaction was stopped with TCA as in the phosphate estimation. After removal of the protein by centrifugation, a 3.0 ml aliquot was made alkaline by adding 0.5 ml of 3 M Tris and the amount of p-nitrophenol present obtained by reading the absorbance of the aliquot at 400 m μ . The SLS method was not found to be entirely suitable for the phosphatase assay because of some non-specific hydrolysis of the substrate at the alkaline pH (=10.0) in the presence of SLS.

Accuracy and Validity of ATP-ase Assay Methods

1. The blank system

Three blank systems were chosen for comparison:

- A. addition of SLS to the incubation mixture immediately prior to starting the reaction with ATP (2 mM).
- B. using heat-inactivated enzyme in the reaction mixture.

The enzyme was completely inactivated by heating to 80^o for 3 mins. Higher temperatures were avoided because this resulted in incomplete solubilisation of the enzyme with SLS.

C. omission of ATP during the incubation period and addition at the end of incubation immediately after terminating the reaction with SLS or TCA.

Table I shows the blank systems. A and B were almost identical. The blank system C had a slightly lower value, probably due to slight ATP hydrolysis occurring in systems A and B during incubation. The similarity of systems A and B together indicates the complete inactivation of the enzyme by SLS. The absorbance of the blank was mainly due to the phosphate content of the ATP solution which slowly hydrolysed, when stored at 0°C (approximately 1-2% per week at pH 7.4).

Blank system A was found to be most convenient with the SLS method; method B was used with the TCA method.

Table II shows that the presence of solubilised protein present in the SLS method does not interfere with the determination of added phosphate.

2. Presence of ATP during the phosphate estimation

Since the Fiske and Subbarow method employs strong acid capable of hydrolysing ATP, it was necessary to determine whether this might interfere with the method. The estimation of standard phosphate by the SLS method in the absence of ATP was compared to that in the presence of ATP. The results can be seen in Table III. The calibration curves in the presence and absence of ATP are almost identical over a 20 min period despite the continuing hydrolysis of ATP by the acid molybdate. The colour reaction is virtually complete by 10 min.

Table I. Comparison of 3 Blank Systems

Absorbancy at 745 mμ after Incubation for 60 Mins at 37°C			
	System A	System B	System C
Expt. 1	0.106	0.104	0.092
2	0.109	0.106	0.095
3	0.108	0.106	0.094
Mean	0.108	0.105	0.094

Table II. Recovery of Phosphate in the Presence of Solubilised Ghost Protein

Absorbancy at 745 mμ			
	0.5 μmole Pi	1.0 μmole Pi	1.5 μmole Pi
Protein Absent	0.39	0.81	1.20
Protein Present	0.42	0.82	1.20

3. Comparison of ATP-ase activity determined by the SLS and TCA methods

In order to confirm the validity of the phosphate assay using SLS, the ATP-ase activity as determined by this method was compared with the activity obtained by the TCA method: columns A and C, respectively, Tables IV and V. Table IV shows the mean activity and standard deviation obtained from five replicate tubes for each method, whilst Table V compares the activity obtained from seven individual assays. The standard deviation values in this latter case are of the differences between the two activities in the two methods. Good correlation between the two methods was obtained.

4. Validity of the coupled-enzyme method

Fig. 3 shows the effect of adding increasing amounts of NADH to an incubation mixture containing ghost protein upon the optical density of the suspension. There is a linear relationship between the amount of NADH present and the extinction of the suspension.

The ATP-ase activity in the presence of the pyruvate kinase-lactic dehydrogenase system was linear with respect to time over the concentration range of ATP tested (0.05 - 3.0 mM). Under these conditions, the amount of NADH oxidized in a given time was proportional to the volume of ghosts present between pH 6.5 and 8.25 (Fig. 4). Although the higher concentrations of ATP (3 mM) could substantially reduce the initial velocity of the PK-LDH system with respect to added ADP, under the experimental conditions in which the

Table IV. Comparison of ATP-ase Activity Determined by the SLS Method and the TCA Method

Activity - $\mu\text{mole Pi formed/ml ghosts/hr}$						
	SLS method Method A		SLS \bar{c} PK-LDH Method B		TCA Method C	
Total-ATP-ase	0.51	SD \pm 0.009	0.49	\pm 0.007	0.51	\pm 0.008
OI-ATP-ase	0.13	\pm 0.004	0.14	\pm 0.004	0.12	\pm 0.008

Table V. Comparison of ATP-ase Activity Determined By the SLS and the TCA Methods

Activity - $\mu\text{mole Pi formed/ml ghost/hr}$			
	A SLS method	B TCA method	SD of A-B
Total-ATP-ase	1.50	1.49	\pm 0.033
OI-ATP-ase	0.64	0.62	\pm 0.055

Fig. 3. The Effect of NADH Concentration upon the Absorbance of the reaction Mixture

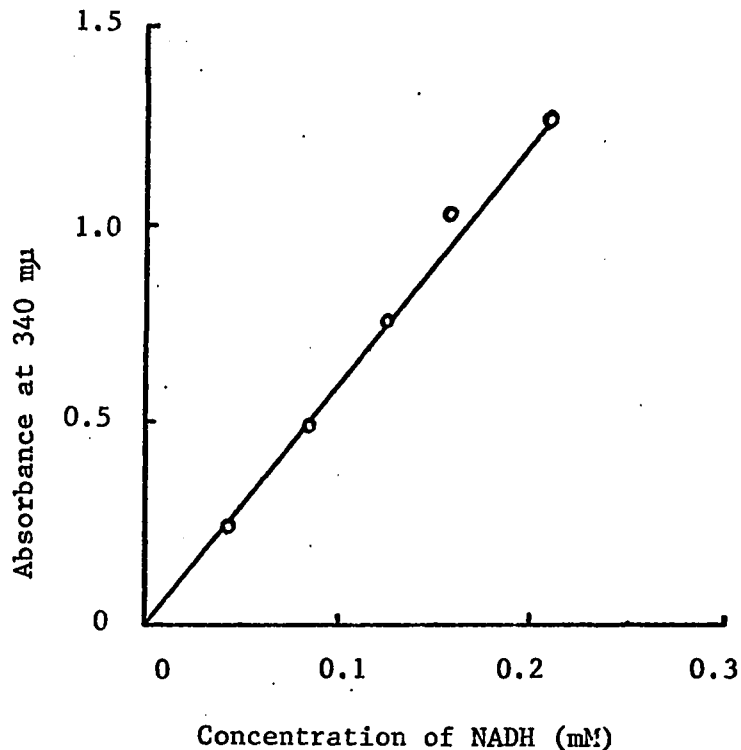

Composition of the reaction mixture- 3mls containing Na 100mM, K 16 mM, Mg 3 mM, TES 30mM, 0.5 ml ghost, pH 7.4.

Table VI. Comparison of ATP-ase Activity Determined by Phosphatase Estimation and by NADH Oxidation

	Activity μ mole Pi formed/ml ghost/hr	
	Activity by Pi	Activity by NADH
Expt. 1		
Total-activity	0.93	0.90
OI-activity	0.48	0.51
Expt. 2		
Total activity	0.56	0.59
Expt. 3		
Total activity	1.15	1.06

Fig. 4. The Effect of Enzyme Concentration upon the Rate of Oxidation of NADH by Red Cell Membrane ATP-ase in the Coupled System

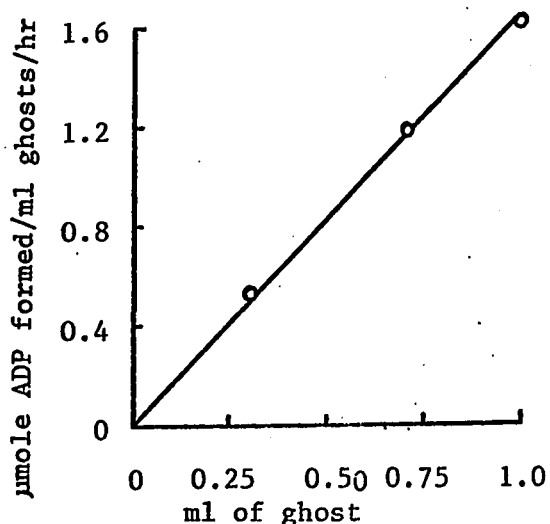

Assay conditions- Na 100 mM, K 16 mM, Mg 3 mM, Tris-ATP 3mM, PEP 0.83 mM, NADH 0.24 mM, PK 10 μg, LDH 12.5 μg, TES 30 mM, pH 7.4.

Fig. 5. The Effect of ADP upon the Absorbance of the ATP-ase Reaction Mixture Containing the PK-LDH System in the Presence of Triton X-100

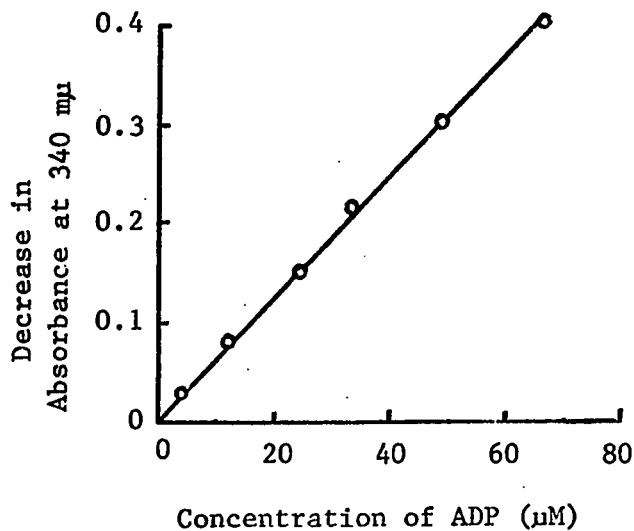

Composition of the reaction mixture - 3mls ATP-ase incubation mixture(Na 100 mM, K 16 mM, Mg 3 mM, ATP 3 mM, TES 30 mM, 0.5 ml ghost, pH 7.4), 0.4 ml of 10% TX-100, 0.5 ml PK-LDH system(PK 10μg, LDH 12.5 μg, 0.72 μmole NADH, 2.5 μmole PEP).

PK-LDH system was used only the ATP-ase was rate-limiting.

The data in Table VI show that in the presence of the coupled enzyme system, the molar amount of phosphate formed by the ATP-ase reaction is equal to the molar amount of NADH oxidized. Reference to Table IV, Method B, shows that the amount of phosphate formed in the presence of the PK-LDH system is virtually the same as the amount released in its absence. The presence of the cardiac glycoside ouabain had no effect upon the function of the PK-LDH system.

That Triton-X-100 does not affect the linearity of the coupled method is shown in Fig. 5 in which increasing amounts of ADP were added to an incubation mixture containing the PK-LDH system in the presence of 0.4% Triton X-100. The same curve was obtained in the presence or absence of ATP (3 mM). Although concentrations of 0.4% TX-100 were routinely used, concentrations as high as 1% had little effect upon the activity of the system.

IV. RESULTS

Initial ATP-ase and phosphatase assays showed that under the usual conditions of assay (p. 26), the amount of phosphate or p-nitrophenol formed in a given time was proportional to the quantity of cells present, and for a given quantity of cells the amount of phosphate or p-nitrophenol formed increased linearly with time for at least an hour (except in the case of reconstituted cells) (Figs. 6A, 6B, 7 and 8).

A large portion of the ATP-ase activity can be seen to be inhibited by the cardiac glycoside ouabain, the remaining activity corresponding to the activity present in the absence of the alkali metal ions Na and K. The activity occurring in the presence of Na + K + Mg will be referred to as the total ATP-ase activity; the activity occurring in the presence of Na + K + Mg + ouabain as the ouabain-insensitive or glycoside-insensitive activity (OI-activity). The difference between these two activities; i.e. that portion of the activity depending upon the presence of Na + K ions, is termed the ouabain-sensitive or glycoside-sensitive activity (OS-activity). No detectable activity was found to occur in the absence of Mg. The OS-activity usually occurs as 50-70% of the total activity in ghosts prepared by the method of Weed (71,72).

In Table VII, the variation in certain parameters of the ghost preparation can be seen. The activity of the ghosts was not directly related to the protein content of the ghost, nor was the activity expressed on a unit ghost basis without variation. Since the activity of the preparation is sensitive

Fig. 6. The Time Course of Phosphate Liberation from ATP by (A) Red Cell Ghosts (B) Reconstituted Cells

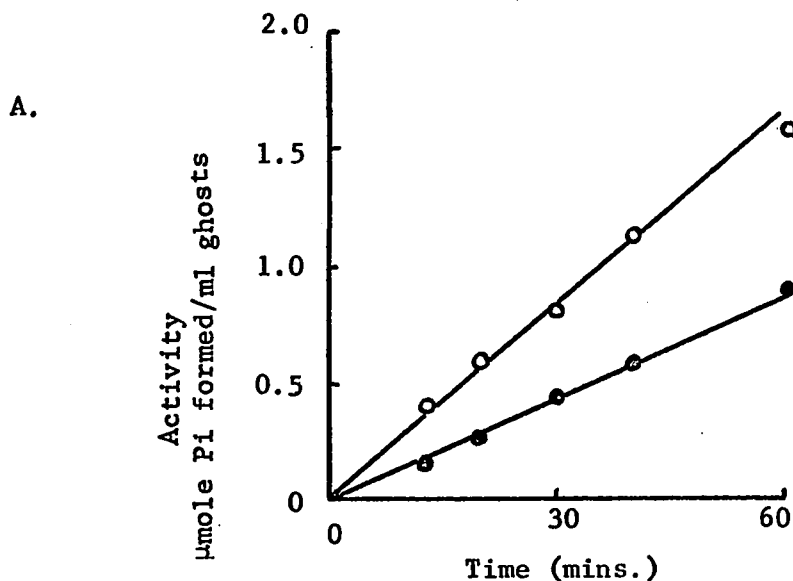

Assay conditions - Na 110 mM, K 16 mM, Mg 2 mM, ATP 2 mM, Tris 20 mM, pH 7.4. (o) glycoside absent (●) ouabain 0.1 mM

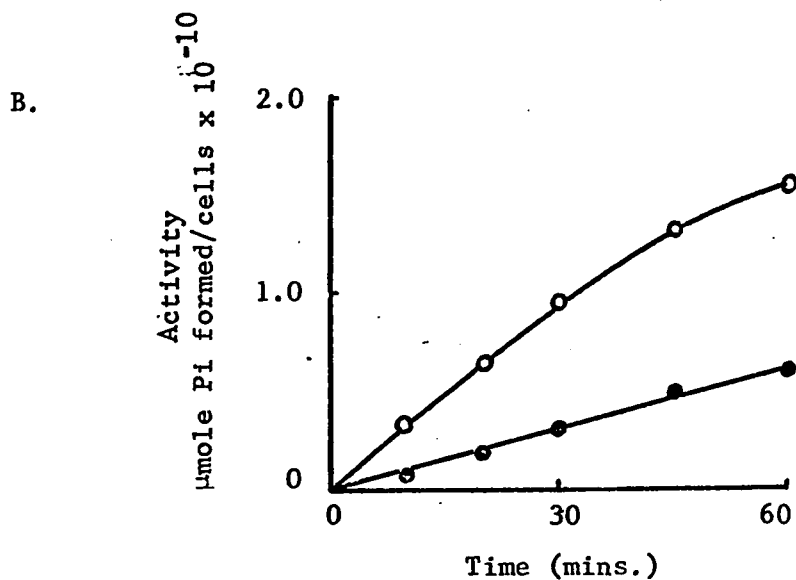

Assay conditions - Na 110 mM, K 16 mM, Tris 20 mM, pH 7.4. The cells were reconstituted in a solution containing 2 mM Mg and 2 mM ATP. The reconstituted cells contained 1.8 mM/litre cells ATP. (o) glycoside absent (●) ouabain 0.12 mM.

Fig. 7. The Time Course of p-nitrophenol Liberation from PNPP by Red Cell Ghosts

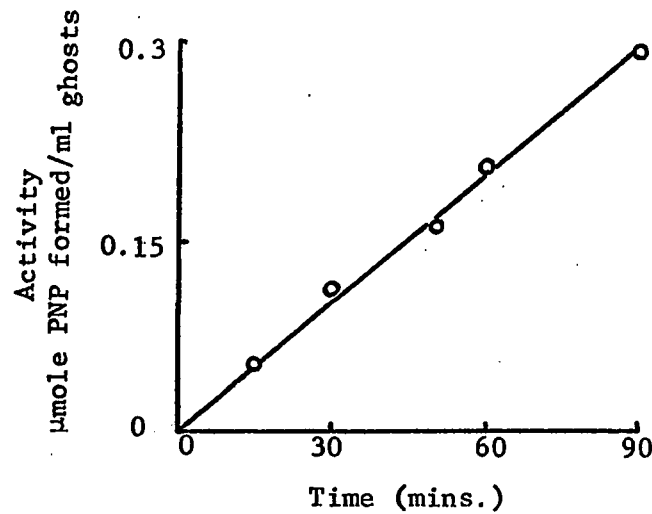

Assay conditions - K 16 mM, Mg 2 mM, PNPP 1.54 mM, Tris 156 mM, pH 7.4

Fig. 8. The Effect of Enzyme Concentration upon the Rate of Liberation of PNP from PNPP by Red Cell Ghosts

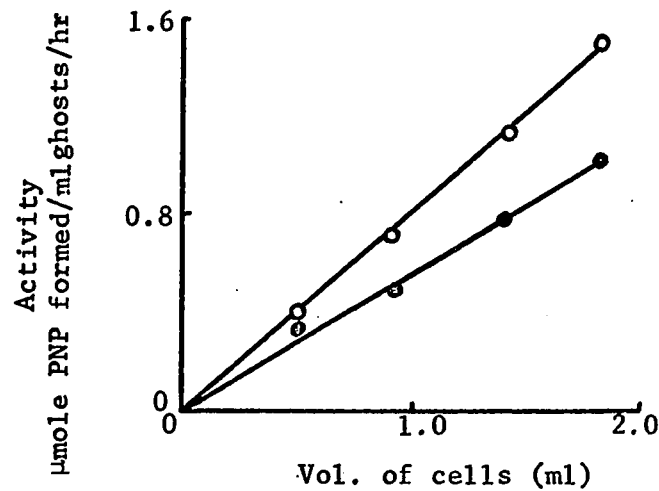

Assay conditions - K 10 mM, Mg 7 mM, Tris-PNPP 5 mM, TES 30 mM, pH 7.4. (o) K present (●) K absent

Table VII. Variability of Several Parameters of the Ghost Preparation

Preparation No.	No. of ghosts /ml x 10 ¹⁰	mg protein /cell x 10 ⁻⁹	Activity $\mu\text{mole/ml}$ ghosts/hr		Activity $\mu\text{mole/mg}$ protein/hr x 10 ⁻¹		Activity $\mu\text{mole/ghost}$ /hr x 10 ⁻¹⁰		Ratio Total/OI
			Total	OI	Total	OI	Total	OI	
1	3.56	0.86	2.05	0.91	6.75	2.99	5.76	2.56	2.25
3	1.42	1.13	0.77	0.34	4.79	2.11	5.42	2.40	2.26
7	3.78	1.01	2.28	1.05	5.92	2.73	6.04	2.78	2.18
15	2.61	1.04	1.40	0.55	5.15	2.02	5.37	2.10	2.55
19	3.74	1.15	1.61	0.57	3.74	1.32	4.31	1.52	2.83
20	5.20	1.13	1.45	0.64	2.45	1.08	2.79	1.23	2.27
22	2.95	1.50	1.78	0.72	4.03	1.63	6.04	2.44	2.48

Assay conditions - Na 100 mM, K 16 mM, Mg 3 mM, ATP 2 mM, TES 30 mM, pH 7.4. 0.5 mM ouabain added to obtain the OI-activity.

to washing procedures (see Figs. 30 and 31), the variation in activity is probably due to changes in the ratio of washing fluid to cells washed.

The p-nitrophenyl phosphatase activity of the ghosts, hereafter referred to as phosphatase activity, can also be conveniently divided into two components: a Mg-dependent activity requiring the presence of Mg ions, and a K-dependent component. The latter is the difference between the activity in the presence of Mg + K and the activity in the presence of Mg alone. A more detailed investigation of the properties of the phosphatase will be discussed later (p. 91).

The ATP-ase activity of the ghosts is fairly stable for two to three weeks at 0°C, though a loss in the total activity accompanied by a decrease in the OS:OI ratio usually occurs. Tables VIIIA and VIIIB show one effect of 'ageing' upon the ATP-ase activity of the ghosts. The data shown here are not necessarily meant to represent typical 'ageing' effects in the ghosts but are included because of the interesting change in character of the ATP-ase. There is little change in total activity over the 'ageing' period but a marked decrease from 1.02 to 0.25 in the OS:OI ratio. This type of change appears to occur when a large proportion of the ghosts are exposed to air, as happens when the volume of ghosts in a container decrease as the ghosts are used for experimental purposes. Table VIIIB shows an example of this type of change produced by storing 4 mls of ghosts in a 50 ml container (producing a large surface area:vol. of ghosts ratio) for a week at 0°C.

Table VIII A. The Effect of 'Ageing' upon the ATP-ase Activity of Red Cell Ghosts

Day of assay	1	2	5	6	7	8
Total-ATP-ase	1.05	1.10	1.08	1.12	1.17	1.23
OI - ATP-ase	0.52	0.65	0.61	0.77	0.77	0.99
OS - ATP-ase	0.53	0.45	0.47	0.35	0.40	0.24
Ratio OS:OI	1.02	0.69	0.78	0.46	0.52	0.25

Activity - μ mole Pi formed/ml cells/hr
 Assay Conditions - Na 100 mM, K 16 mM, Mg 3 mM, ATP 2 mM, TES 30 mM, pH 7.4, ouabain 0.5 mM added to obtain the OI-activity.

Table VIII B. The Effect of 'Ageing' Upon the ATP-ase Activity of Red Cell Ghosts

Day of assay	1	7
Total-ATP-ase	1.40	1.45
OI - ATP-ase	0.57	0.79
OS - ATP-ase	0.83	0.66
Ratio OS:OI	1.48	0.84

Activity - μ mole Pi formed/ml cells/hr
 Assay Conditions - Na 100 mM, K 16 mM, Mg 3 mM, ATP 2 mM, TES 30 mM, pH 7.4, 0.5 mM ouabain added to obtain the OI-activity.

Such a change in OS:OI ratio without much change in total activity is of interest because of the unknown relationship between the two components of the ATP-ase: viz. whether they are separate enzymes or whether they are different forms of the same enzyme in which perhaps the OI-component has lost its sensitivity to Na and K. The changes in the OS:OI ratio shown in Table VIIIA and VIIIB are suggestive of a change of OS-activity into OI-activity although the change might also be caused by an activation of the OI-component accompanied by a loss in OS-activity. Attempts to 'artificially age' the ghosts were not particularly successful. Procedures such as oxygenation of the ghosts, or rotating a small volume of ghosts in a test-tube at 0°C to expose a large surface area of the ghosts to air produced variable changes in the OS:OI ratio, usually accompanied by a loss in total activity.

SECTION I

Interaction of Erythrocyte Membrane ATP-ase with Na, K, Mg, ATP and Ouabain

The work presented here is an attempt to study the interaction of Na and K with the ATP-ase system of the red cell, and the inhibition of the cation-stimulated ATP-ase by ouabain. The effects of Mg and ATP upon the ATP-ase activity have also been investigated.

Since changes in the osmolarity (and ionic strength) of the incubation medium would occur in these experiments when the concentration of Na and K were varied, preliminary experiments were carried out to see if such changes affected the ATP-ase activity. Only large changes in osmolarity (or ionic strength) inhibited the ATP-ase activity (Table IX). Moderate changes of the size expected in the kinetic experiments did not affect the ATP-ase activity; e.g. the ATP-ase activity was the same in the presence of 0.8 mM K + 14 mM Na as in the presence of 0.8 mM K, 14 mM Na + 120 mM choline chloride.

The effect of low concentrations of Na ion, and the influence of small amounts of ouabain, upon the rate of ATP-ase activity can be seen in Fig. 9. The ghosts were preincubated for one hour in the presence of ouabain to obtain a constant degree of inhibition during the assay period. The activity, measured as the amount of phosphate formed, was assumed to represent initial velocities since less than 15% of the substrate was consumed during the assay period, even

Table IX. The Effect of Increasing the Tonicity upon the ATP-ase Activity of Red Cell Ghosts

	% Inhibition of Activity		
	150 mM Tris	300 mM Tris	400 mM Tris
Total-ATP-ase	14	36	77
OI - ATP-ase	12	34	86
OS - ATP-ase	15	36	73
	150 mM Imidazole	300 mM Imidazole	400 mM Imidazole
Total-ATP-ase	19	39	62
OI - ATP-ase	5	21	41
OS - ATP-ase	30	49	80
	300 mM Glucose	600 mM Glucose	900 mM Glucose
Total-ATP-ase	6	9	20
OI - ATP-ase	0	21	14
OS - ATP-ase	9	4	24

Assay conditions: - Na 106 mM, K 16 mM, Mg 2 mM, ATP 2 mM, Tris 15.6 mM, pH 7.4. 0.1 mM ouabain added to obtain the OI-ATP-ase.

Fig. 9. The Effect of Na Concentration upon the Ouabain-Sensitive ATP-ase Activity of Red Cell Ghosts in the Presence of Low Ouabain Concentrations

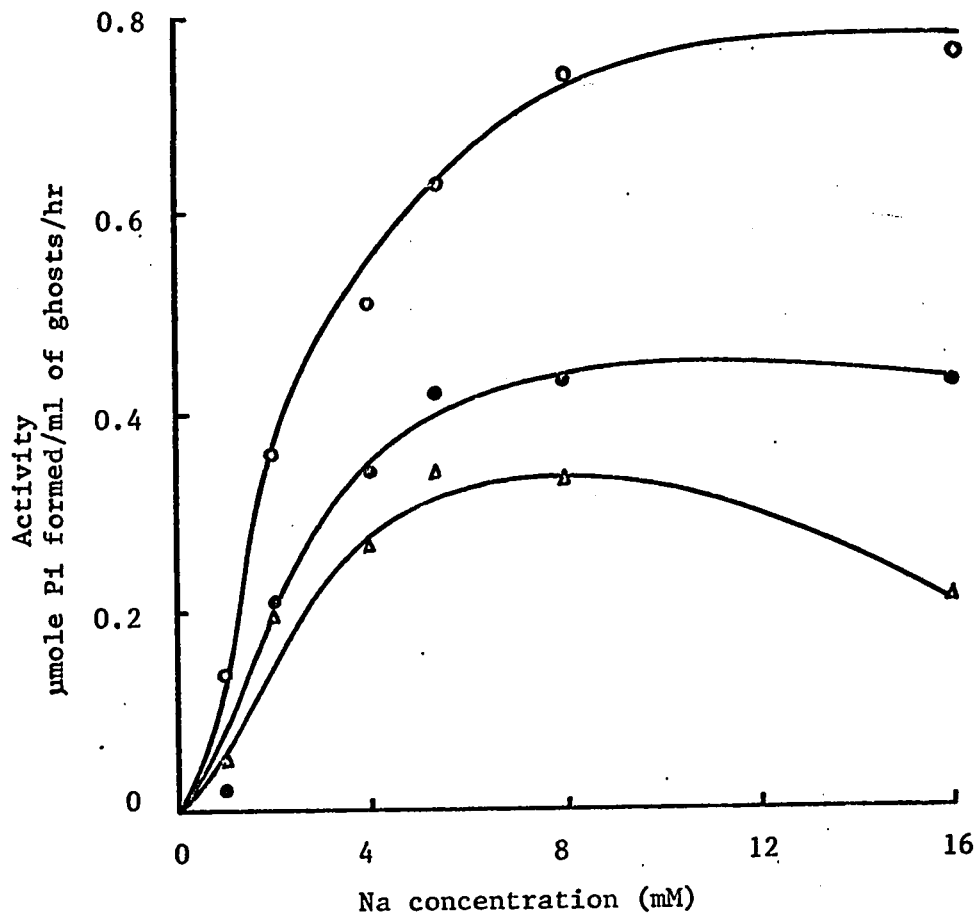

Assay Conditions. - K 16 mM, Mg 3 mM, Tris-ATP 2 mM, TES 30 mM,

pH 7.4. (o) total OS - activity (●) OS-activity in the presence of 5×10^{-8} M ouabain, (Δ) OS-activity in the presence of 10^{-7} M ouabain.

when the velocity approached V_{\max} . The sigmoidal curve of rate as a function of Na ion concentration and the upward bending lines obtained when these data are plotted according to the method of Lineweaver and Burk (78) (Fig. 10), suggest that the enzyme interacts in some way with more than one molecule of Na. Such behaviour, characteristic of certain allosteric proteins (79-81) may more adequately be described by the Hill equation, originally formulated to describe the interaction of haemoglobin with oxygen.

$$\log \left(\frac{V_{\max}}{v} - 1 \right) = \log K - n \log S$$

Thus when $\log \left(\frac{V_{\max}}{v} - 1 \right)$ is plotted against $\log S$, a straight line relationship is obtained with a slope equal to $-n$. It has been suggested that when $n > 1$ there is cooperative interaction between two or more binding sites for the same ligand.

A Hill plot of the data presented in Fig. 9 can be seen in Fig. 11. In this and subsequent Hill plots, any points at which substrate inhibition occurred, and those points nearest V_{\max} , were omitted because of the inaccuracy of V_{\max} taken from curved Lineweaver-Burk plots. The Hill plots in Fig. 11 gave an n value of 2 - 2.6, both in the presence and absence of ouabain. The K_m value for Na of 2.4 mM changed little in the presence of the glycoside. It is of interest to note that unless concentrations of Na less than 5 mM were used, sigmoidal curves of rate as a function of Na concentration were no longer obtained and Lineweaver-Burk plots now have a straight line

Fig. 10. A Double Reciprocal Plot of the Effect of Na Concentration upon the Ouabain-Sensitive ATP-ase Activity of Red Cell Ghosts in the Presence of Low Ouabain Concentrations

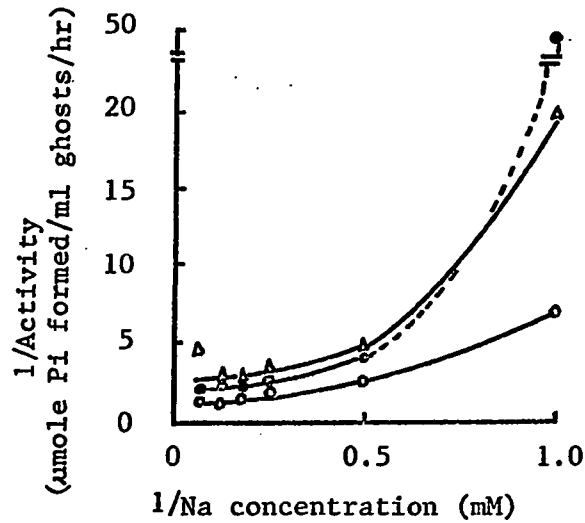

Assay conditions - K 16 mM, Mg 3 mM, Tris-ATP 2 mM, TES 30 mM, pH 7.4. (o) total OS-activity (●) OS-activity in the presence of 5×10^{-8} M ouabain (Δ) OS-activity in the presence of 10^{-7} M ouabain.

Fig. 11. Hill Plots of Ouabain-Sensitive ATP-ase Activity Expressed as a Function of Na Concentration

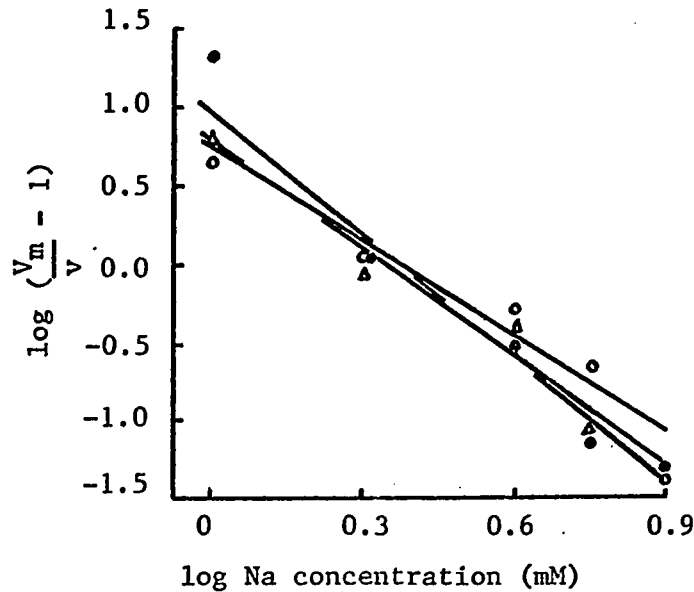

Data from Fig. 9. (o) Total OS-activity (●) OS-activity in the presence of 5×10^{-8} M ouabain (Δ) OS-activity in the presence of 10^{-7} M ouabain.

relationship (Fig. 12). Hill plots now give an n value of unity.

When activity is plotted as a function of Na concentration at fixed K concentration (Fig. 13), the sigmoidicity of the curves increases as the K concentration is raised. However, the value of n obtained from a Hill plot of these data is not markedly different at the three different K concentrations (Fig. 14). As might be expected, the K_m value of Na increases from 2.9 mM to 12 mM as the fixed K concentration is raised from 10 mM to 100 mM.

The effect of K concentration and the influence of small amounts of ouabain upon the rate of OS-ATP-ase activity can be seen in Fig. 15. Although the curves of rate as a function of K concentration are not markedly sigmoidal (Fig. 15), upward bending Lineweaver-Burk plots are obtained from these data (Fig. 16). Hill plots (Fig. 17) gave an n value of 1.2 - 1.4, both in the presence and absence of ouabain. The K_m value increases from 1.0 mM in the absence of ouabain to 4.9 mM in the presence of ouabain.

The type of inhibition produced by ouabain in relation to the activation by Na and K could not be satisfactorily determined from the curved Lineweaver-Burk plots. The amount of inhibition produced by low concentrations of ouabain remains fairly constant over a wide range of Na concentration (Table XI). Although it has been suggested that Na might potentiate the inhibitory action of ouabain, such an effect was not observed with Na concentrations up to 400 mM in the presence of

Fig. 12. The Effect of Na Concentration upon the Ouabain-Sensitive ATP-ase Activity of Red Cell Ghosts in the Presence of Low Ouabain Concentrations

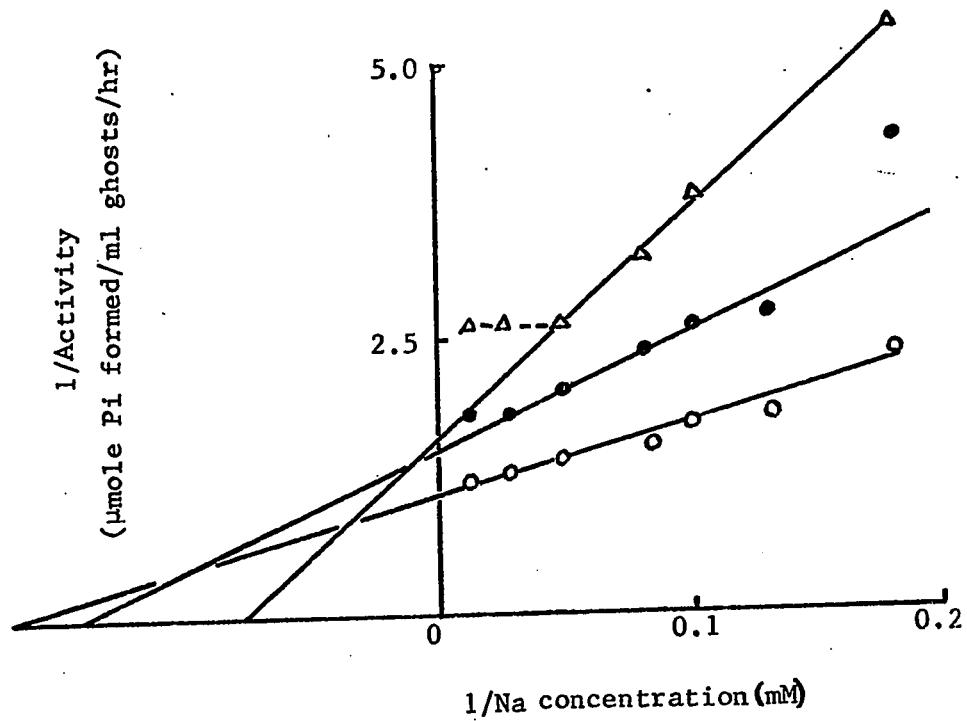

Assay conditions - K 16 mM, Mg 3 mM, Tris-ATP 2 mM, TES 30 mM, pH 7.4. (○) total OS-activity (●) OS-activity in the presence of 1.25×10^{-7} M ouabain (Δ) OS-activity in the presence of 2.5×10^{-7} M ouabain.

Fig. 13. The Effect of Na Concentration at Various K Concentrations upon the Ouabain-Sensitive-ATP-ase of Red Cell Ghosts

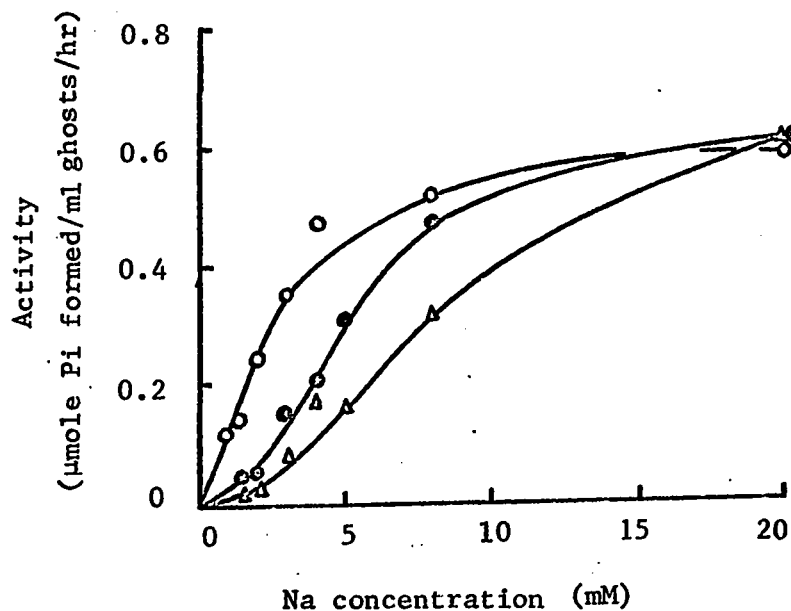

Assay conditions - Mg 3 mM, Tris-ATP 2 mM, TES 30 mM, pH 7.4. (o) K 10 mM (●) K 60 mM (Δ) K 100 mM.

Fig. 14. Hill Plots of the Ouabain-Sensitive ATP-ase of Red Cell Ghosts as a Function of Na Concentration at Various K Concentrations

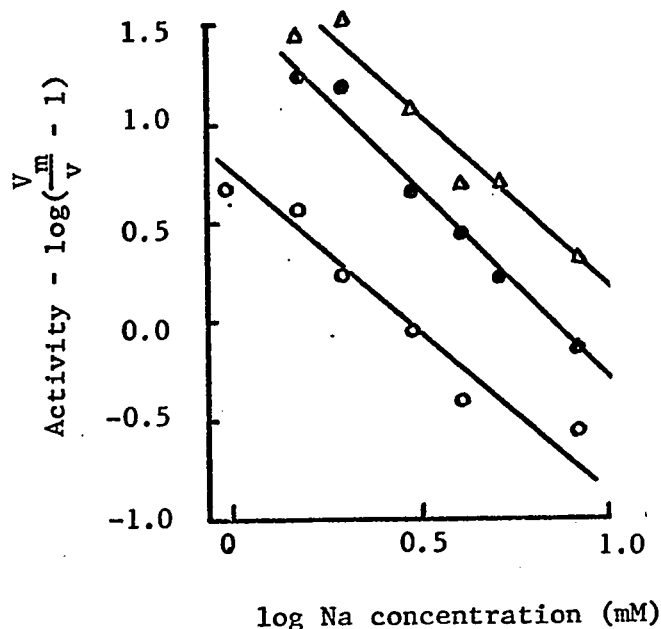

Data from Fig. 13. (o) K 10 mM (●) K 60 mM (Δ) K 100 mM.

Fig. 15. The Effect of K Concentration upon the Ouabain-Sensitive ATP-ase Activity of Red Cell Ghosts in the Presence of Low Concentrations of Ouabain

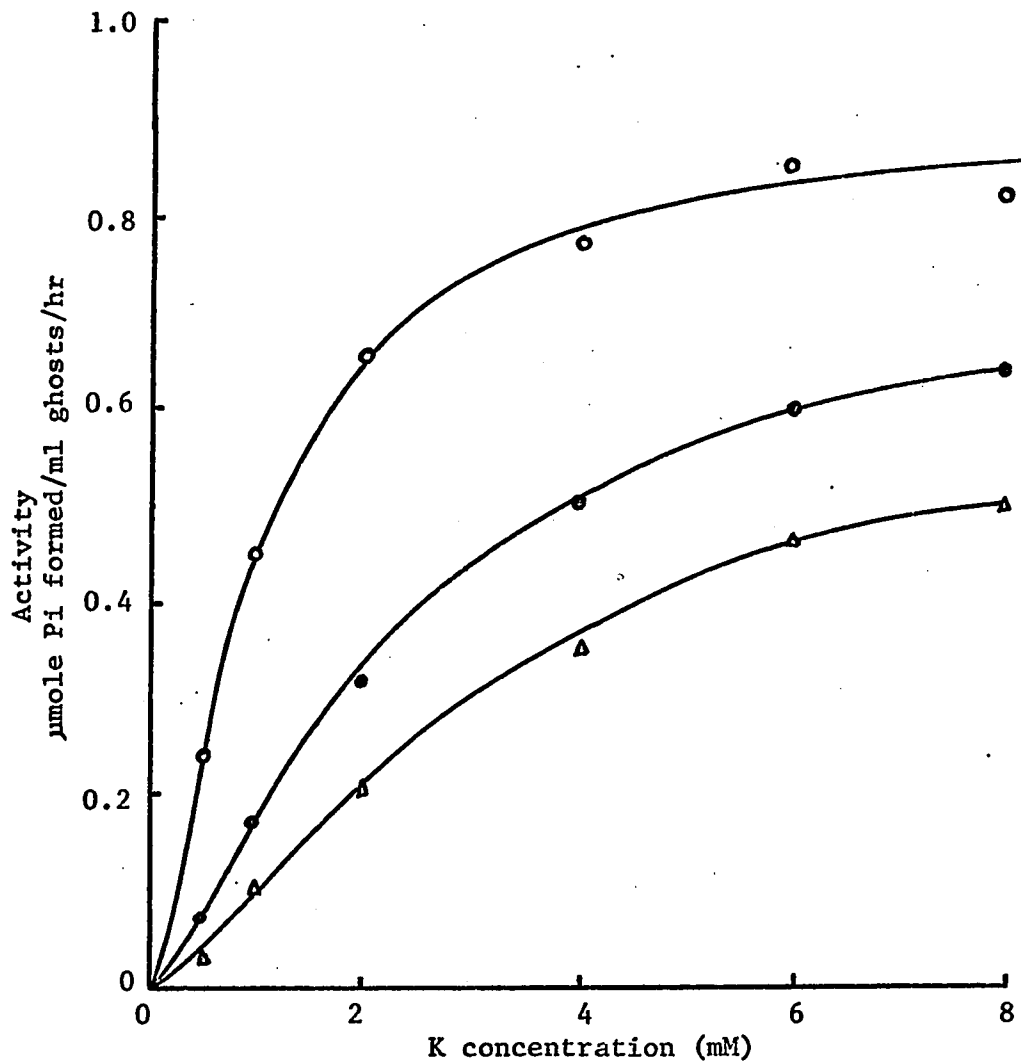

Assay Conditions - Na 112 mM, Mg 3 mM, Tris-ATP 1.77 mM, TES 30 mM, pH 7.4. (o) total OS-activity (●) OS-activity in the presence of 5×10^{-8} M ouabain (Δ) OS-activity in the presence of 10^{-7} M ouabain.

Fig. 16. A Double Reciprocal Plot Of the Effect of K Concentration upon the Ouabain-Sensitive ATP-ase Activity of Red Cell Ghosts in the Presence of Low Ouabain Concentrations

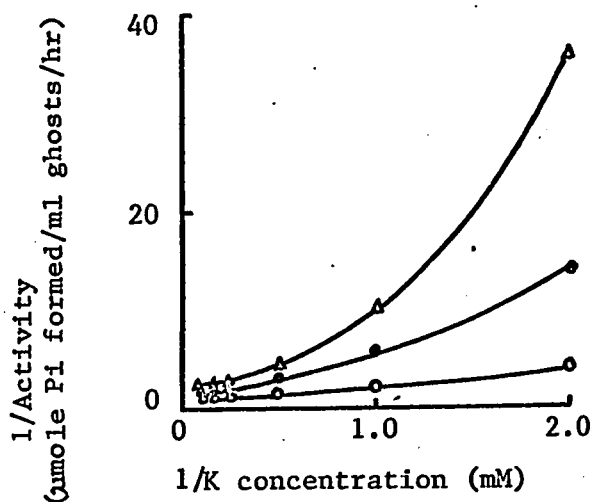

Data from Fig. 15.⁸ (o) total OS-activity (●) OS-activity in the presence of 5×10^{-8} M ouabain (Δ) OS-activity in the presence of 10^{-7} M

Fig. 17. Hill Plots of the Ouabain-Sensitive ATP-ase Activity Expressed as a Function of K Concentration

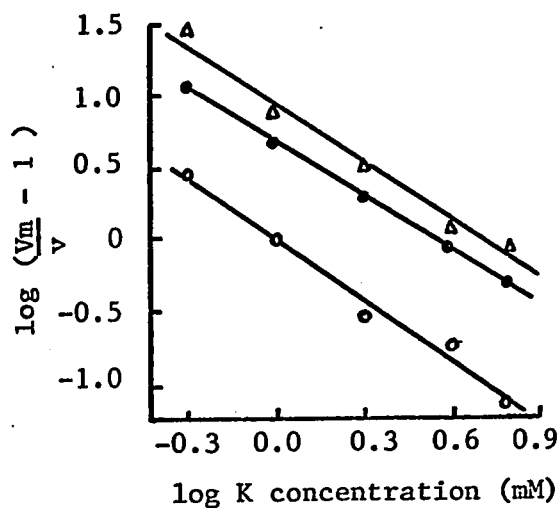

Data from Fig. 15.⁸ (o) total OS-activity (●) OS-activity in the presence of 5×10^{-8} M ouabain (Δ) OS-activity in the presence of 10^{-7} M ouabain.

Table X. The Effect of K Concentration upon the Inhibition by Ouabain of the Glycoside - Sensitive ATP-ase Activity of Red Cell Ghosts

K concn. (mM)	0.5	1.0	2.0	4.0	6.0	8.0
% inhibition of the OS-ATP-ase by 5×10^{-8} M ouabain	69	63	53	35	28	22
% inhibition by 10^{-7} M ouabain	90	77	68	55	45	39

Assay conditions - Na 112 mM, Mg 3 mM, ATP-Tris 1.74 mM, TES 30 mM, pH 7.4. 0.5 mM ouabain added to obtain OI-ATP-ase.

Table XI. The Effect of Na Concentration upon the Inhibition by Ouabain of the Glycoside-Sensitive ATP-ase Activity of Red Cell Ghosts

Na concn. (mM)	1.0	2.0	4.0	5.3	8.0	16
% inhibition of the OS-ATP-ase by 5×10^{-8} M ouabain	92	42	40	34	41	47

Assay conditions - K 16 mM, Mg 3 mM, ATP-Tris 2 mM, TES 90 mM, pH 7.4. 0.5 mM ouabain added to obtain the OI-ATP-ase.

16 mM K. However, if the K concentration is lowered to 0.5 mM an apparent increase in the percentage inhibition is obtained when the Na concentration is raised from 20 to 205 mM (Table XII).

In contrast, the degree of inhibition at low concentrations of ouabain is decreased by raising the K concentration (Table X), suggesting a type of competitive inhibition by ouabain. Plotting the data in Fig. 15 by the method of Hunter and Downs (82)* did not suggest the existence of two distinct components in the inhibition of K activation by ouabain, as had been found with the inhibition of K uptake by Na in yeast (144). In order to obtain more direct information on the relationship between K and the glycoside, the Na:K ratio was kept constant at 7:1 to try to eliminate any variation in the Na-K interaction, and the response of the OS-ATP-ase to increasing K concentration (or Na) was measured under these conditions. In contrast to the previous plots at constant Na concentration, the Lineweaver-Burk plots are now straight lines (Fig. 18) and indicate a competitive inhibition by ouabain.

* In this method, $I \frac{\alpha}{1-\alpha}$ is plotted against S, where I and S are the concentrations of inhibition and substrate, respectively, and α is the fractional activity (i.e. the ratio of the activity in the presence of a given concentration of substrate and inhibitor to the activity without inhibitor at the same substrate concentration). For competitive inhibition, a straight line with a slope equal to K_i/K_m is obtained with a Y intercept of K_i . For non-competitive inhibition, a horizontal line is obtained with a Y intercept of K_i .

Table XII. The Effect of a High Na Concentration Relative to K Concentration Upon the Inhibition by Ouabain of the Glycoside-Sensitive ATP-ase of Red Cell Ghosts

Na concn. (mM)	22	36	55	80	105	205
(a) Total OS-ATP-ase activity μ mole/ml/hr	0.56	0.57	0.37	0.37	0.24	0.11
(b) OS-ATP-ase activity in the presence of 5×10^{-8} M ouabain	0.44	0.41	0.24	0.21	0.12	0.02
% inhibition of the OS-ATP-ase by 5×10^{-8} M ouabain	22	29	37	42	52	78
(a) - (b)	0.12	0.16	0.13	0.16	0.12	0.09

Assay conditions - K 0.5 mM, Mg 3 mM, Tris-ATP 2 mM, TES 30 mM, pH 7.4, + 0.5 mM ouabain to obtain the OI-ATP-ase.

Fig. 18. The Lineweaver-Burk Analysis of Ouabain Inhibition of Ouabain-Sensitive ATP-ase Activity of Red Cell Ghosts in the Presence of a Constant Na:K Ratio of 7:1

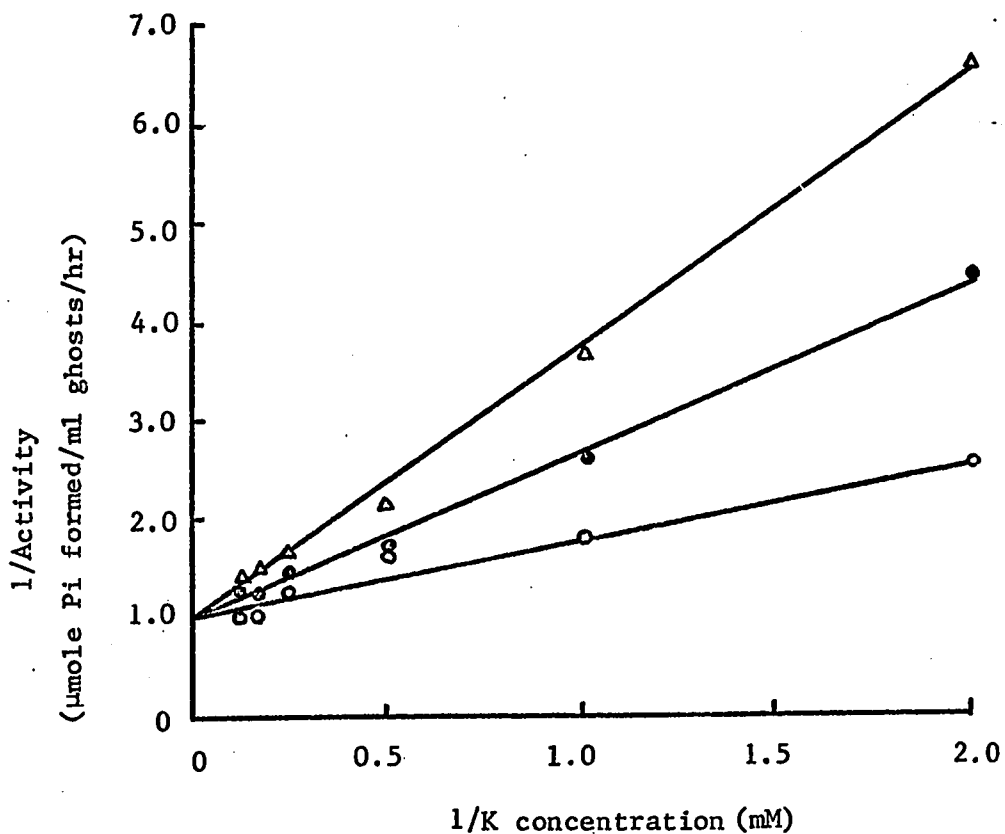

Assay conditions - Na:K ratio = 7:1, Mg 3 mM, Tris-ATP 1.77 mM, TES 30 mM, pH 7.4. (○) total OS-activity (●) OS-activity in the presence of 5 × 10⁻⁸ M ouabain (Δ) OS-activity in the presence of 10⁻⁷ M ouabain.

Under certain conditions, Hoffmann (65) found that K could completely prevent ouabain from binding to red cells (to which they are known to bind firmly [7]), using the rate of efflux of ^{24}Na as a measure of glycoside retention. This suggests that the inhibitory effect of the glycosides is modified by K, preventing them from binding rather than preventing glycosides already bound from acting. Similar experiments were tried here with the ghost preparation using the ATP-ase activity as an index of glycoside binding.

In the first type of experiment, outlined in the following flowsheet, the ghosts were initially incubated for

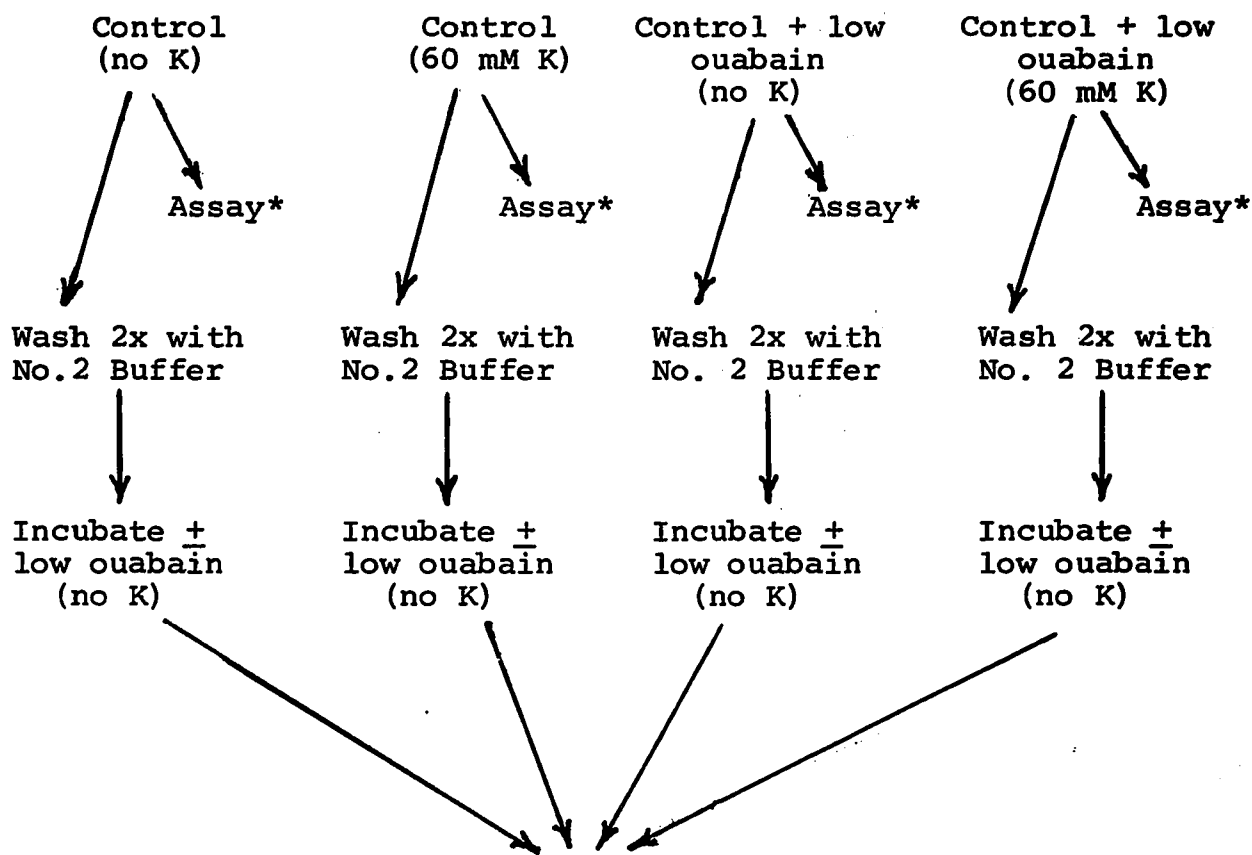

*Assay - Rate of ATP-ase as a function of K concentration

60 mins in the presence or absence of low ouabain concentration ($5 \times 10^{-8} \text{M}$) and with 60 mM K also present or absent. With one aliquot of the ghosts, the rate of ATP-ase activity as a function of K concentration was assayed, whilst a second aliquot was washed, reincubated with or without ouabain for 60 mins, and once again assayed for ATP-ase activity as a function of K concentration. If K prevents ouabain binding, ghosts initially incubated in the presence of 60 mM K and low ouabain concentration should retain higher activity than those incubated initially with low ouabain but no K (providing that ouabain is not washed off the membrane). With the ghost preparation, no difference in ATP-ase activity was found after the washing stage between ghosts incubated initially in the presence of ouabain and those incubated in its absence; nor did exposure to 60 mM K during the initial incubation have any effect (Table XIII). These results suggest that either ouabain does not bind firmly to the ghosts or else it is removed during the washing procedure.

In contrast, Hoffman (65) found that the glycosides were retained by red cells during the washing procedure and that initial exposure to 60 mM K completely prevented the glycoside from binding.

An alternative procedure was tried in which the order of addition of K and the glycoside to the ghosts was changed; viz. the ghosts were preincubated for 30 mins with (a) K alone, ouabain being added at the start of the ATP-ase assay; (b) both K and ouabain together; (c) ouabain alone, K being added at the start of the ATP-ase assay. No difference in the

Legend to Table XIII.

A - Ghosts were preincubated in the absence of K, with or without 5×10^{-8} M ouabain present, for 60 minutes at 37°C . ATP and K were then added and the ATP-ase activity assayed.

B - Ghosts were preincubated in the absence of K for 60 minutes at 37°C , washed twice with 10 volumes of No.2 Buffer and the ghosts made up to their original volume in No.2 Buffer. The ghosts were then reincubated in the absence of K, with or without 5×10^{-8} M ouabain present, and then K and ATP added and the ATP-ase activity assayed.

C - As B but 5×10^{-8} M ouabain present during the initial incubation.

D - As A.

E - As B but 60 mM K present during the initial incubation.

F - As C but 60 mM K present during the initial incubation.

The basic incubation medium contained 100 mM Na, 3 mM Mg, 30 mM TES, pH 7.4. ATP, K, and ouabain were added where necessary. The OI-ATP-ase was assayed in the presence of 5×10^{-4} M ouabain.

degree of inhibition by ouabain was found as a result of adding K and ouabain at these different times, suggesting that the glycoside does not bind as firmly to ghosts as it does to red cells (Table XIV). Using this procedure with red cells, Hoffman was able to show that the rate of ^{24}Na efflux from the cells decreased in the order, K before ouabain $>$ K with ouabain, $>$ ouabain before K, indicating that K prevents the binding of the glycoside.

The relationship between Mg concentration and ATP-ase activity at several ATP concentrations can be seen in Figs. 19A, B and C (activity obtained by measuring the amount of ADP formed after terminating the reaction with TX-100). From these data, a plot of activity as a function of Mg:ATP ratio (Fig. 21) suggests that the optimal ratio probably does not significantly differ from 1. A similar series of curves depicting the relationship between ATP concentration and activity at several Mg concentrations can be seen in Figs. 20B, C, and D. Under these conditions, optimal activity is obtained at a Mg:ATP ratio of 1.0 at all Mg concentrations (Fig. 22). Fig. 20A is a plot of rate as a function of Mg:ATP concentration when the ratio is kept constant at 1.0.

Lineweaver-Burk analysis of the effect of Mg and the effect of ATP upon the rate of ATP-ase activity produced straight line plots, and n values obtained from Hill plots were close to unity. Table XV shows the K_m values for Mg at different ATP concentrations, and Table XVI the K_m values for ATP at different Mg concentrations.

Table XIV. The Effect of the Time of Addition of Ouabain upon the Inhibition of Red Cell Ghost ATP-ase Activity

Type of ATP-ase activity. μ mole/ml ghosts/hr.	K concentration during ATP-ase assay (mM)			
	1.0	2.0	6.0	30.0
Total activity	1.45	1.58	1.85	1.79
K before 5×10^{-8} M ouabain	1.17	1.40	1.62	1.71
K with 5×10^{-8} M ouabain	1.22	1.33	1.60	1.73
K after 5×10^{-8} M ouabain	1.17	1.35	1.61	1.71
OI-activity	1.01	0.99	0.98	0.97

ATP-ase assay conditions - Na 100 mM, Mg 3 mM, Tris-ATP 2 mM, TES 30 mM, pH 7.4. 0.5 mM ouabain added to obtain the OI-activity.

Fig. 19. The Effect of Mg Concentration upon the ATP-ase Activity of Red Cell Ghosts at Various ATP Concentrations

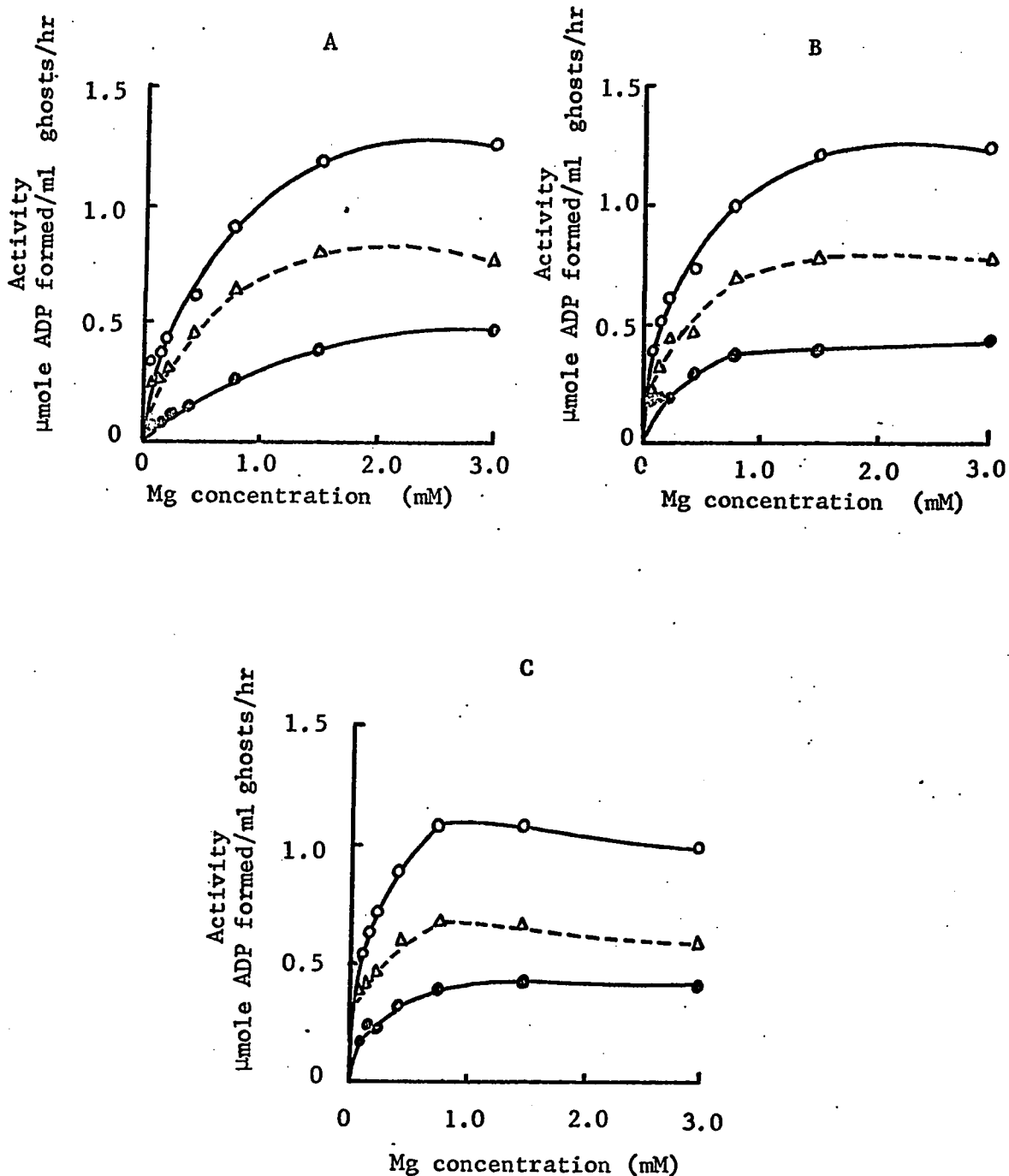

Assay conditions - Na 100 mM, K 16 mM, TES 30 mM, pH 7.4.
 (o) glycoside absent (●) ouabain 0.5 mM (Δ) the difference between the two curves representing the ouabain-sensitive component. Fig. 19A - ATP constant at 2 mM; Fig. 19B - ATP constant at 1 mM; Fig. 19C - ATP constant at 0.5 mM.

Fig. 20. The Effect of ATP Concentration upon ATP-ase Activity of Red Cell Ghosts at Various Mg Concentration

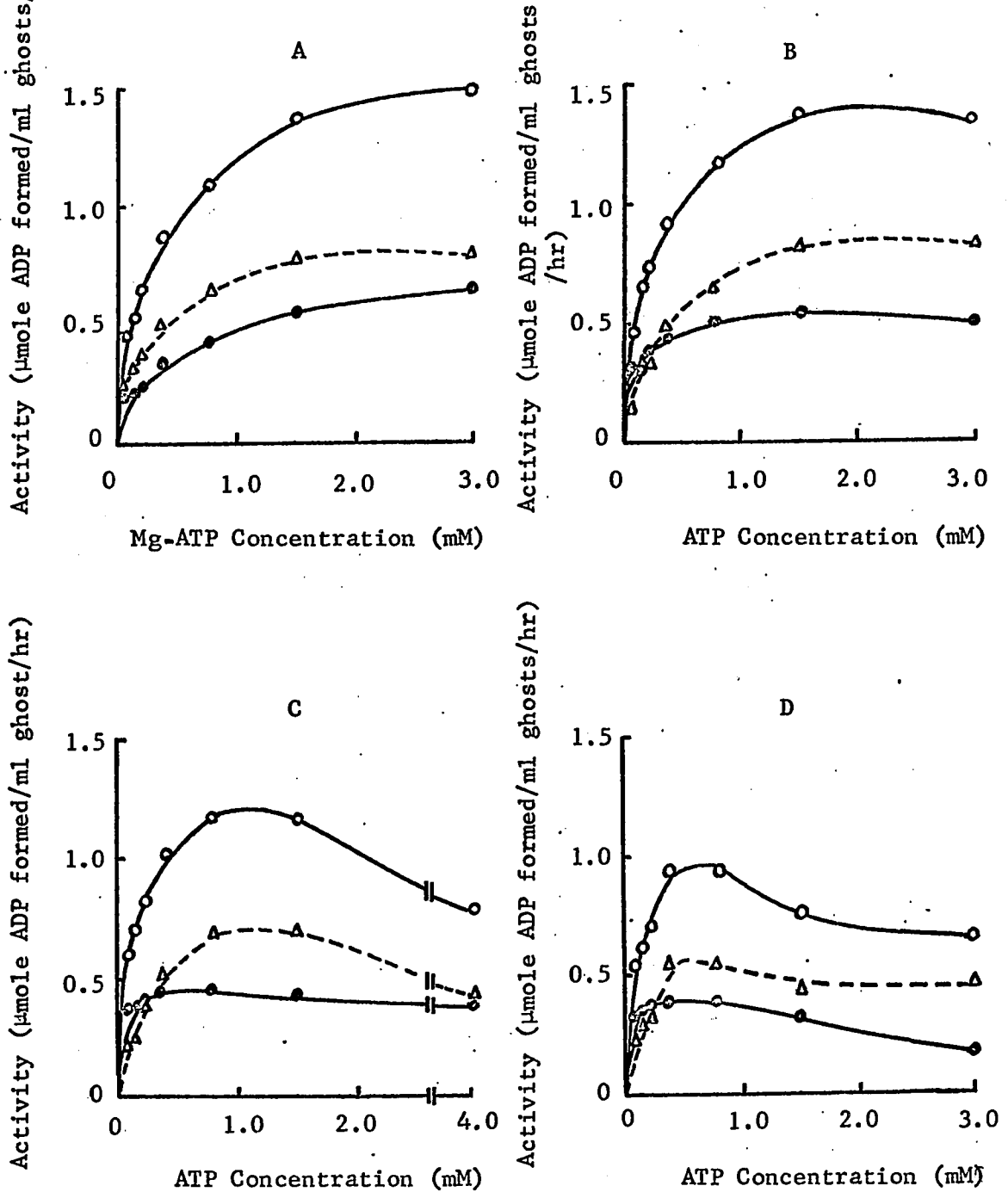

Assay conditions - Na 100 mM, K 16 mM, TES 30 mM, pH 7.4. (o) glycoside absent (•) ouabain 0.5 M (Δ) the difference between the two curves representing the OS-activity. Fig. 20A - Mg:ATP ratio maintained constant at 1:1; Fig. 20B - Mg constant at 2.0mM; Fig. 20C - Mg constant at 1.0mM; Fig. 20D - Mg constant at 0.5mM

Fig. 21. The Effect of Mg:ATP Ratio as a Function of ATP Concentration upon the OS-ATP-ase Activity of Red Cell Ghosts

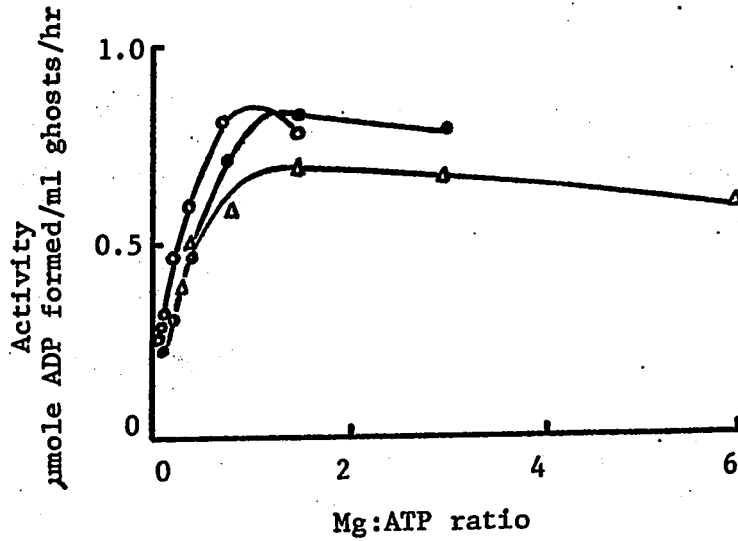

Data taken from Fig. 19 A, B, and C. (o) ATP constant at 2mM (●) ATP constant at 1mM (Δ) ATP constant at 0.5mM

Fig. 22. The Effect of ATP:Mg Ratio as a Function of Mg Concentration upon the OS-ATP-ase Activity of Red Cell Ghosts

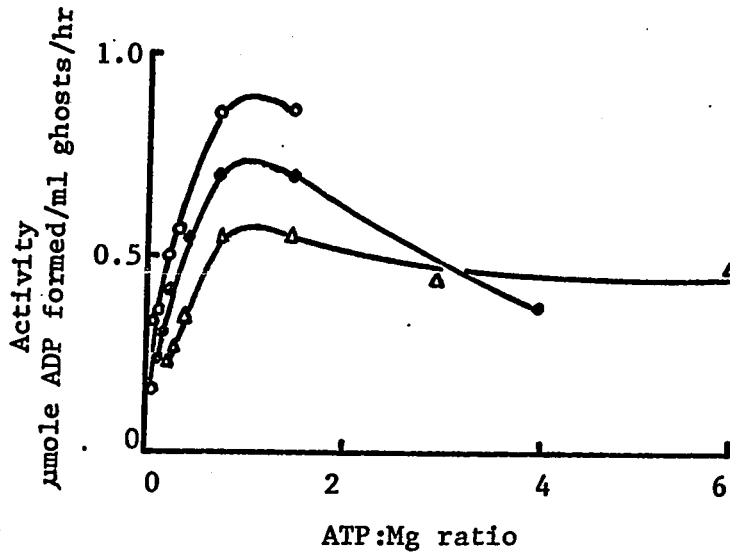

Data taken from Fig. 20 B, C, and D. (o) Mg constant at 2mM (●) Mg constant at 1mM (Δ) Mg constant at 0.5mM

Table XV. K_m Values of Mg for Red Cell Ghost ATP-ase at Various Concentrations of ATP

	ATP 0.5 mM	ATP 1.0 mM	ATP 2.0 mM
OS-ATP-ase K_m (mM)	0.12	0.36	0.45
OI-ATP-ase K_m (mM)	0.20	0.26	0.80

Data obtained from Lineweaver-Burk analysis of Figs. 19 A, B and C.

Table XVI. K_m Values of ATP for Red Cell Ghost ATP-ase at Various Concentrations of Mg

	Mg 0.5 mM	Mg 1.0 mM	Mg 2.0 mM	Mg:ATP 1:1
OS-ATP-ase K_m (mM)	0.33	0.38	0.42	0.24
OI-ATP-ase K_m (mM)	0.02	0.05	0.14	0.32

Data obtained from Lineweaver-Burk analysis of Figs. 20 A, B, C and D.

Fig. 23 shows the effect of ATP concentration upon the ATP-ase activity at three different pH values. The optimum pH appears to lie between 7.4 and 8.2. Linear Lineweaver-Burk plots were obtained at pH 7.4 and 8.2. At pH 6.5, the plot was slightly curved and analysis by means of the Hill equation gave an n value of 1.4.

Fig. 23. The Effect of ATP Concentration at Various pH Values upon the ATP-ase Activity of Red Cell Ghosts

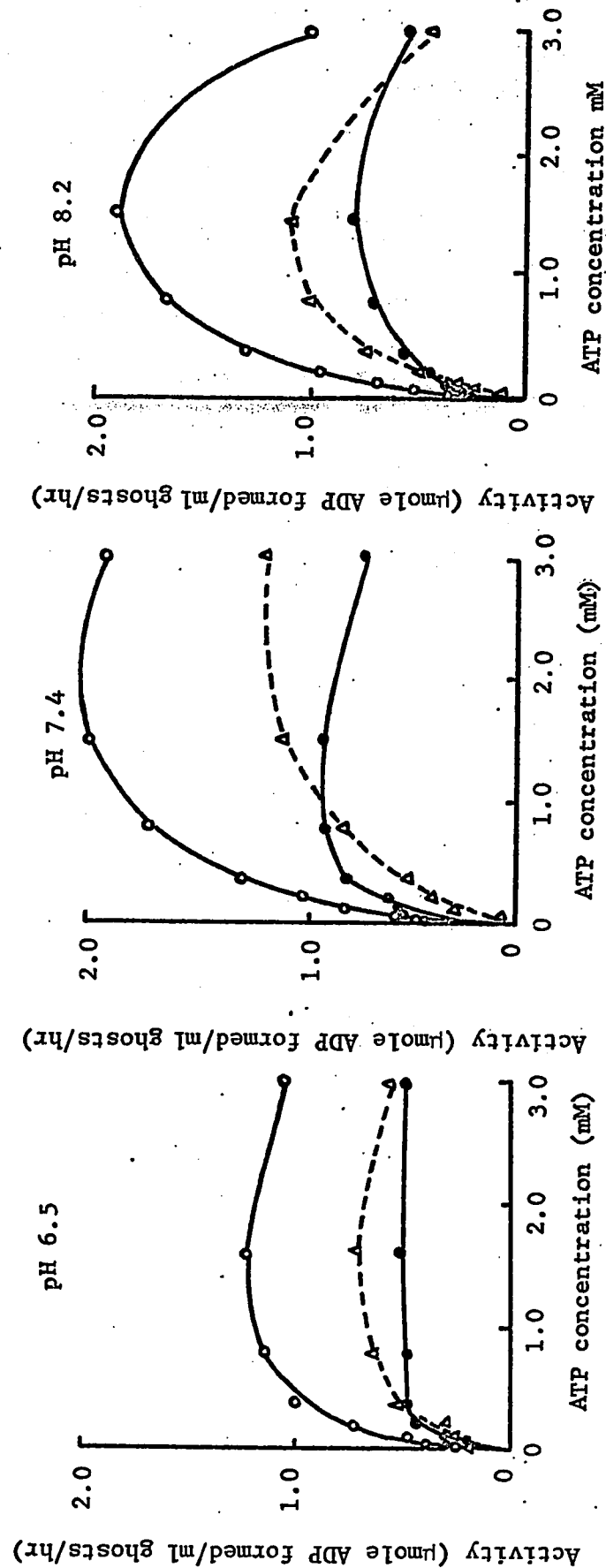

Assay conditions - Na 107 mM, K 16 mM, Mg 3 mM, PEP 0.83 mM, NADH 0.23 mM, PK 10 μg, LDH 12.5 μg, 100 mM MES, TE Tris for pH 6.5, 7.4 and 8.25, respectively. (o) total ATP-ase activity (●) ouabain 0.1 mM (Δ) the difference between the two curves representing the ouabain-sensitive component.

SECTION II

The Effect of Calcium Upon the ATP-ase Activity of Reconstituted Cells

The Effect of Calcium Upon the Osmotic Haemolysis of Erythrocytes

In order to try to locate the site of action of Ca with respect to erythrocyte ATP-ase activity, reconstituted cells were prepared into which Ca was introduced at the time of haemolysis. By comparing the ATP-ase activity of these cells with reconstituted cells which did not contain Ca but whose surrounding medium contained Ca, the effects of both 'internal' and 'external' Ca upon the components of ATP-ase activity could be determined.

Initial experiments showed that the ATP-ase activity of reconstituted cells was qualitatively the same as that of the membrane preparation. For a given quantity of cells (containing approximately 2 mmoles ATP/litre cells), the rate of formation of phosphate increased linearly with time for at least 30 mins, and for a given period of time, the amount of phosphate formed was proportional to the volume of cells present.

In Table XVII, the hydrolysis of ATP by two types of reconstituted cells is compared. Into the cells of type (1) Mg-ATP was incorporated at the time of haemolysis, whereas Mg alone was incorporated into the cells of type (2). However, ATP was added to the medium in which cells of type (2) were assayed but not to the medium for cells of type (1). Type (1) cells, in which ATP is intracellular, hydrolyse ATP at a much

Table XVII. The Hydrolysis of ATP by Reconstituted Cells

Activity μmole/cell/hr x 10 ⁻¹⁰	(1) Cells haemolysed in 2.0 mM Mg:ATP. No ATP in exter- nal medium.	(2) Cells reconstituted in 2.0 mM Mg . ATP in external medium.	(3) Cells (1) with EDTA in exter- nal medium	(4) Cells (2) with EDTA in exter- nal medium
Total-ATP-ase	10.20	2.55	8.16	1.84
OI - ATP-ase	3.75	1.81	2.32	1.04
OS - ATP-ase	6.45	0.74	5.84	0.84
OS:OI	1.72	0.41	2.51	0.78

Assay condition - Na 125 mM, K 18.5 mM, Mg 2.2 mM, Tris 21 mM, pH 7.4, 0.1 mM ouabain added to obtain the OI-activity. When added to the external medium ATP = 2 mM, EDTA Na₂ = 2.25 mM.

faster rate than cells of type (2) in which the ATP is extracellular. Further, the ouabain-sensitive:ouabain-insensitive ratio (OS:OI) is much larger in the case of cells of type (1) than type (2). There was no phosphate formation when cells reconstituted in the absence of ATP were incubated in an ATP-free medium. Table XVII also shows the effect of adding EDTA to the assay medium of both types of cell. The concentration of EDTA was of the same magnitude as the Mg in the medium. A reduction in total activity of both types of cells occurred, with a more marked inhibition of the OI-ATP-ase, thus raising the OS:OI ratio.

Although the progress curve of phosphate formation was linear for at least 30 mins, it was observed that in some experiments in which the cells had high ATP-ase activity, the amount of ATP incorporated into the cells was not enough to account for the amount of phosphate formed (assuming ATP was being hydrolysed only to ADP).

As can be seen in Fig. 24, the rate of phosphate formation is higher than the apparent rate of ATP loss. Theoretically, after 40 mins all the ATP should have been removed; however, the cells still contained a concentration of ATP 30% of the starting level. The ATP is being removed at slightly more than half the rate of phosphate formation. This suggests that the cells are either utilising ADP, or that some ATP synthesising process is occurring. The presence of adenylate kinase in the membrane has been reported (83) and might well account for the reduced rate of ATP loss.

Fig. 24. Progress Curve of Phosphate Formation and ATP Loss in Reconstituted Cells

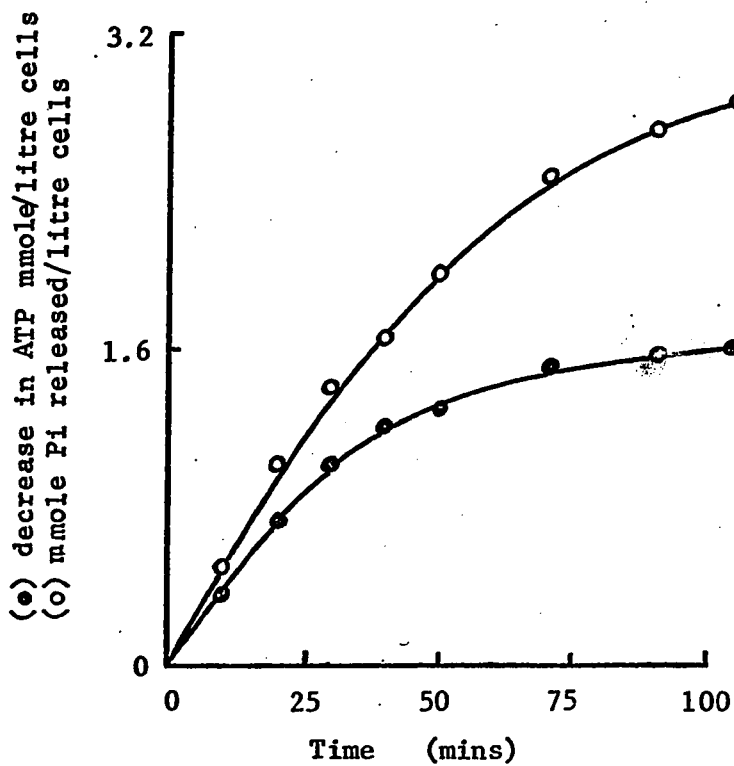

Assay conditions - Na 110 mM, K 16 mM, Mg 2 mM, Tris 20 mM, pH 7.4. ATP concentration at the beginning of the experiment (i.e. at time 0) = 1.75 mmole/litre cells.

Viz.

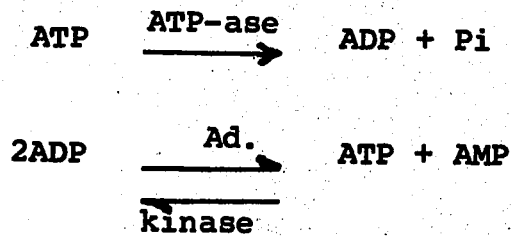

Although the enzymes of the glycolytic pathway are also reported (84,85) to be in the membrane, the concentration of their substrates would be too low to allow them to participate in any significant ATP synthesis.

Reconstituted cells containing varying amounts of calcium were prepared by haemolysing erythrocytes in Mg-ATP solution containing appropriate amounts of Ca, followed by the resealing procedure outlined on page 23. The results of such an experiment can be seen in Table XVIII and Fig. 25. The final Ca ion content of the cells was somewhat lower than that in the haemolysing fluid. The cell ATP, with one exception, and the haemoglobin content of the cells, also with one exception, were reasonably constant throughout the Ca range used. Calcium can be seen to produce a ten-fold activation of the OI-ATP-ase at a concentration of 7.5 to 10.0 mM, followed by a decrease in activity above this concentration. As with the membrane preparation, the OS-ATP-ase appears to be inhibited at all Ca concentrations. However, the concentration of Ca necessary to produce these effects in reconstituted cells is about 10 times higher than that required to produce similar effects in the membrane preparation.

That calcium apparently exerts its effects from within the cell membrane can be seen from Table XIX and Fig. 26.

Fig. 25. The Effect of 'Internal' Ca upon the ATP-ase Activity of Reconstituted Ghosts

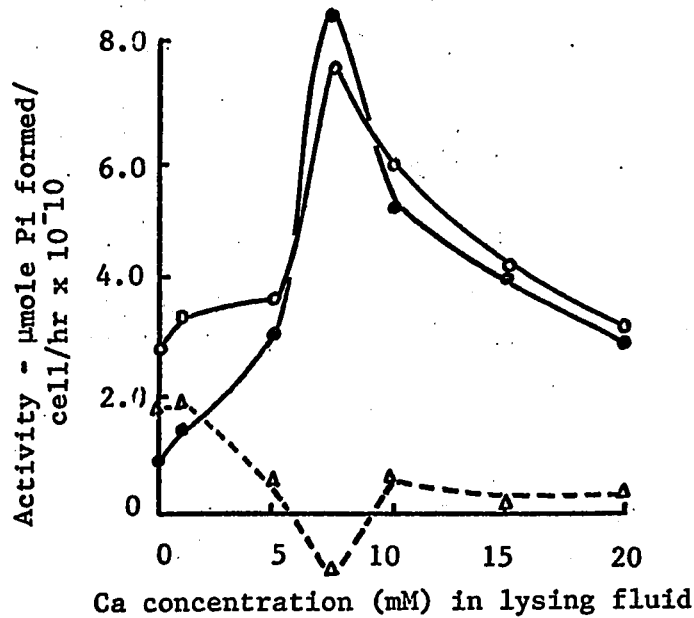

Assay conditions - Na 110 mM, K 16 mM, Mg 2 mM, Tris 20 mM, pH 7.4. (o) glycoside absent (●) ouabain 0.12 mM (Δ) difference between the two curves representing the glycoside-sensitive component.

Fig. 26. The Effect of 'External' Ca upon the ATP-ase Activity of Reconstituted Ghosts

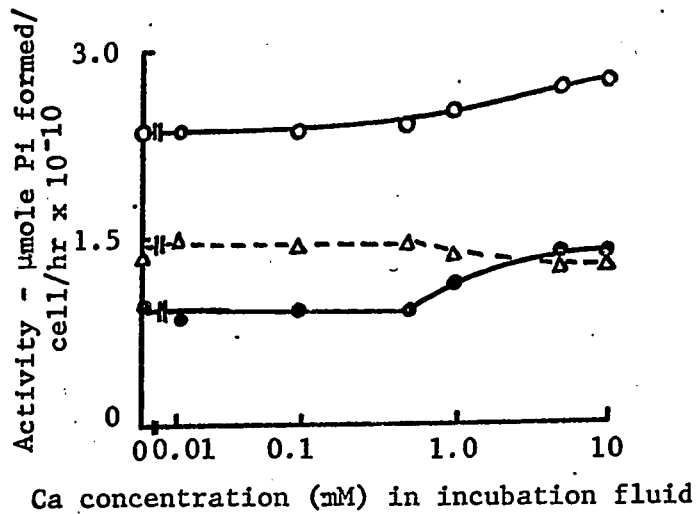

Assay conditions - Na 110 mM, K 16 mM, Mg 2 mM, Tris 20 mM, pH 7.4. (o) glycoside absent (●) ouabain 0.12 mM (Δ) the difference between the two curves representing the ouabain sensitive component. Semi-log scale.

Calcium was not incorporated into these cells at the time of haemolysis, but instead was added to the medium in which the cells were suspended. In contrast to intracellular Ca, extracellular Ca had little effect upon the ATP-ase activity. There was a slight activation of the OI-component at the higher concentrations, possibly due to a slight leakage of calcium through the membrane. However, no real change in the OS-fraction was observed.

It has been suggested that the inhibitory action of calcium may depend upon a competition between Ca and Mg (17). In order to explore this possibility in reconstituted cells, the effect upon the ATPase activity of lysing the cells in 7.5 mM CaCl₂ at two different MgCl₂ concentrations was compared (Table XX). The comparison is not strictly valid since at the higher Mg concentration, the presence of Ca seems to reduce the ATP content of the cells. However, no real indication of an alleviation of the inhibition by Ca of the OS-component was observed. Indeed this component is completely inhibited at the higher Mg concentration. Although the OI-component is somewhat lower at the higher Mg concentration, Ca produces about the same degree of activation at both Mg concentrations.

II. The Effect of Ca upon the Osmotic Haemolysis of Erythrocytes

During the preparation of reconstituted cells, it was observed that the cells were less readily haemolysed in the presence of calcium than in its absence; i.e. the rate of

Table XX. The Effect of 'Internal' Ca at Two Different Levels of Mg on the ATP-ase Activity of Reconstituted Cells

<u>Activity</u> μmoles/cell/hr x 10 ⁻¹⁰	Cells (1)	Cells (2)	Cells (3)	Cells (4)
Total activity	2.91	6.80	2.35	3.15
OI	1.26	6.45	0.91	4.33
OS	1.65	0.35	1.44	0
ATP μmoles/litre of cells	1.89	2.48	1.99	0.99

Assay conditions - Na 110 mM, K 16 mM, Mg 2 mM, Tris 20 mM, pH 7.4. 0.12 mM ouabain added to obtain the OI-activity.

Cells (1) - haemolysed and reconstituted in 4 mM ATP:4 mM Mg

Cells (2) - haemolysed and reconstituted in 4 mM ATP:4 mM Mg + 7.5 mM Ca

Cells (3) - haemolysed and reconstituted in 4 mM ATP:10 mM Mg

Cells (4) - haemolysed and reconstituted in 4 mM ATP:10 mM Mg + 7.5 mM Ca

haemolysis appeared slower in the presence of calcium. In view of this observation, the effect of calcium upon the osmotic haemolysis of erythrocytes was investigated. The blood was usually collected into EDTA, the plasma and white cells were removed, and the red cells washed four times with 1% NaCl solution. The cells were finally suspended in 1% buffered NaCl solution (4 parts 1% NaCl solution + 1 part 0.15 M Tris, pH 7.4 - called for convenience, 1% NaCl) to give a 50% haematocrit. The opacity at 660 m μ of a suspension of red cells in the appropriate buffered NaCl solution (6 ml of solution containing 20 μ l of the 50% suspension) was used as a measure of the amount of haemolysis present. The opacity was measured in a Beckman DU spectrophotometer equipped with a Gilford Model 220 Absorbance Indicator, using a 1 cm light path. The opacity was thus expressed in absorbance units, the apparent absorbance being composed of the light absorbed and the light scattered. The apparent opacity depends not only upon the number of cells present, but also upon their shape and volume.

Cells suspended in 1% NaCl solution were used as a control, and taken to represent 0% haemolysis, whilst the absorbance of the cells in distilled water was taken as 100% haemolysis. Nine minutes after adding the cell suspension to the saline solution, the constancy of the opacity value indicated that haemolysis had virtually ceased. The degree of haemolysis was also determined by measuring the amount of haemoglobin in the supernatant of a cell suspension

after removing the cells by centrifugation. This method gave results qualitatively similar to those of the opacity method. However, since the "haemoglobin method" was less convenient, the opacity method was routinely used except where otherwise stated.

The effect of three different calcium concentrations upon the amount of haemolysis in several NaCl concentrations can be seen in Table XXI and Fig. 27. As a control, saline containing an equi-osmolar amount of choline chloride was used. However, as can be seen in Fig. 27, at this concentration of choline chloride, saline alone and saline + choline chloride produce almost identical curves. It was found that the amount of haemolysis is markedly reduced by the presence of calcium in low concentration. Even concentrations as low as 0.08 mM exert an effect of this type. The effect of calcium is most marked in concentrations of saline producing up to 80% haemolysis; when 90% or more haemolysis is present, calcium has little effect. Magnesium ions did not reduce haemolysis at all (Table XXI). The same phenomenon was observed with heparinised blood, indicating that the effect of Ca was not merely due to a removal of Ca by the EDTA into which the blood was usually collected. The results of an experiment to investigate the possibility that Ca was lost from the membrane during the initial washing of the cells in NaCl solution can be seen in Table XXIII. Washing does not appear to affect either the susceptibility to haemolysis or to the effect of added Ca.

Fig. 27. The Effect of Calcium upon the Osmotic Haemolysis of Erythrocytes

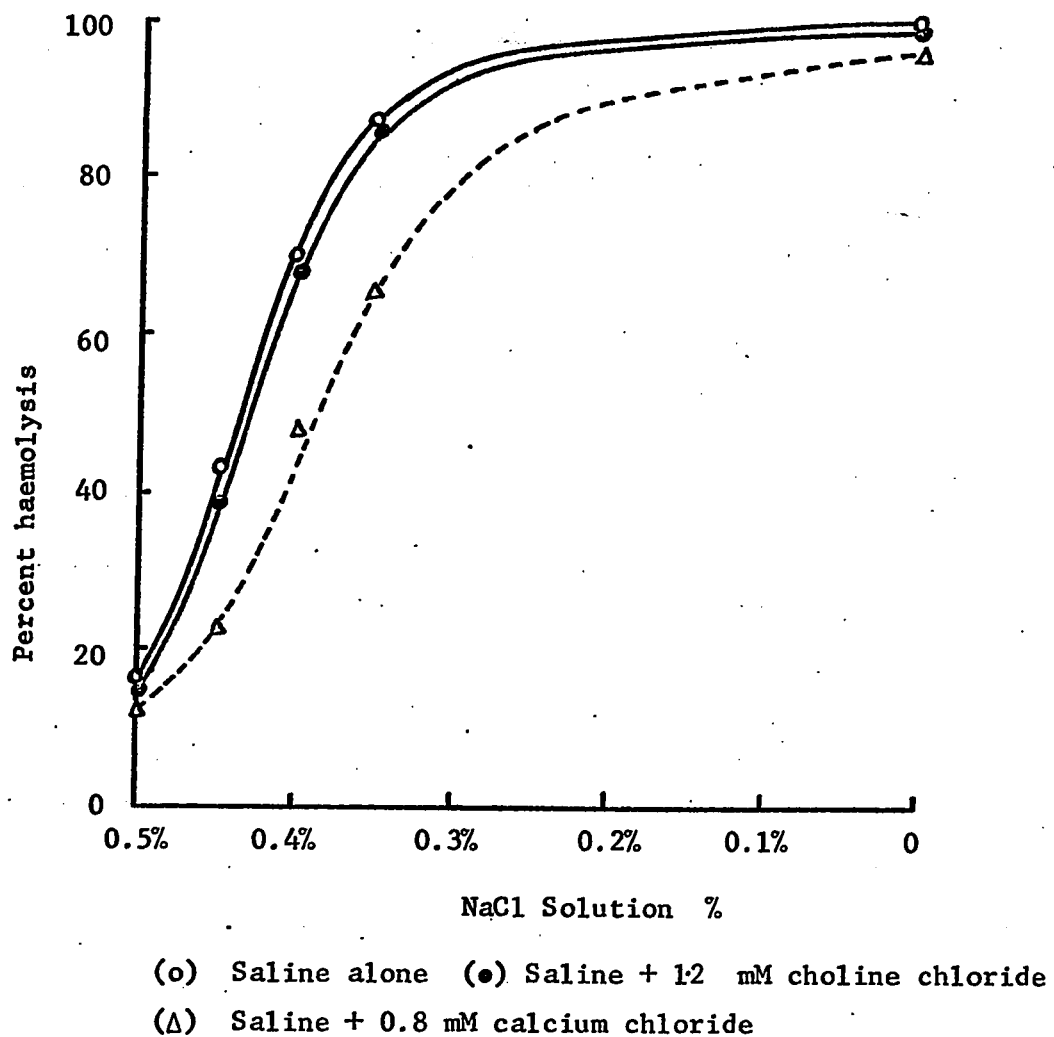

Table XXI. The Effect of Different Ca Concentrations and of Mg upon the Osmotic Haemolysis of Erythrocytes

% NaCl solution	% haemolysis						
	Control (saline +0.12mM Chol.Cl)	Control +0.08mM CaCl ₂	Control (saline +1.2 mM Chol.Cl)	Control +0.8 mM CaCl ₂	Control (saline +3.0 mM Chol.Cl)	Control +2.0 mM CaCl ₂	Control +2.0 mM MgCl ₂
0.50	16	15	16	12	15	15	16
0.45	52	42	40	24	30	21	33
0.40	92	89	90	73	89	67	89
0.35	97	95	97	94	96	92	96
0	99	99	98	96	97	57	98

Table XXII. The Effect of EDTA upon the Osmotic Haemolysis of Erythrocytes in the Presence of Ca

% NaCl solution	% haemolysis				
	Control (saline + 1.2mM Chol.Cl)	Control +0.8 mM Ca	Control + 1.2mM EDTA	Control + EDTA + Ca	
0.50	24	17	22	32	
0.45	59	47	59	71	
0.40	86	79	84	91	
0.30	94	83	93	96	
0	99	97	100	97	

Table XXIII. The Effect of Washing upon the Osmotic Haemolysis of Erythrocytes in the Presence and Absence of 0.8 mM Ca

		% Haemolysis					
% NaCl solution	Whole blood		Cells washed 2x with buffered saline		Cells washed 4x with buffered saline		
	Control	Control + Ca	Control	Control + Ca	Control	Control + Ca	
0.50	25	18	26	15	28	16	
0.45	77	47	67	37	70	41	
0.42	91	70	85	59	87	64	

EDTA had no effect upon the haemolysis of the control suspension, but in the presence of Ca, EDTA not only prevented the anti-haemolytic action of this Ca but also increased the amount of haemolysis at any particular NaCl solution (Table XXII).

That the effects of calcium were not merely due to changes in cell volume or opacity were confirmed by the following observations.

a) The opacity of the cell suspension (20 μ l of 50% suspension per 5 ml saline) in 1% saline containing either 1.2 mM choline chloride or 0.8 mM CaCl_2 was the same.

b) After allowing the cell suspension in 0.4% NaCl solution to equilibrate for nine minutes, 20 μ l of 200 mM CaCl_2 was added to produce a final concentration of 0.8 mM. No change in opacity upon addition of the strong CaCl_2 took place.

c) After allowing a cell suspension in 0.4% NaCl solution to equilibrate for nine minutes (containing either 1.2 mM choline chloride or 0.8 mM CaCl_2), the suspension was restored to isotonic by the addition of 150 μ l of 3 M NaCl solution. The following results were obtained.

Absorbance of suspension
in 0.4% NaCl + choline
chloride

a. Before restoring to
isotonic = 0.363

b. After restoring to
isotonic = 0.435

Absorbance of suspension
in 0.4% NaCl + 0.8 mM
 CaCl_2

a. Before restoring to
isotonic = 0.605

b. After restoring to
isotonic = 0.708

The small increases in absorbance (a to b) are due to shrinkage of the cells upon restoring the solution to isotonic. The large difference in absorbance between the suspension containing Ca and the suspension without Ca is due to the increased haemolysis in the absence of Ca.

One way by which Ca might inhibit the osmotic haemolysis of erythrocytes would be by inducing a selective loss of K from the cells without a concomitant gain of Na. Such a net loss of cation would produce a shrinkage of the cells, thus necessitating a greater change in cell volume in these cells compared to the control before reaching the critical haemolytic volume and the onset of haemolysis. Table XXIV and Figs. 28 and 29 show the results of an experiment designed to test this hypothesis.

No detectable K was lost from either suspension until haemolysis began to occur. Although the cells suspended in Ca solution have apparently lost more K than the control cells for any given degree of haemolysis, the mean cell volume of the cells in both suspensions is virtually the same at all tonicities. Ca also appears to have little effect upon the critical haemolytic volume of the cells. In a plot of packed cell volume against the corresponding degree of haemolysis, the values for both control and Ca-exposed cells fall along the same straight line, suggesting that Ca has little effect upon the cell volume. These results may be compared with those in Table XXV in which the effect of the antibiotic Valinomycin upon osmotic haemolysis was determined.

Legend to Table XXIV.

Experimental conditions - 200ul of red cell suspension (an approximately 50% haematocrit in 1% buffered saline) was mixed with 4 mls of buffered saline of the required tonicity and the mean cell volume of a 1 in 100,000 suspension of these cells in 1% buffered saline was immediately obtained by means of a ¹MCV (mean cell volume) computer attached to a Coulter Counter. ² The volume of unhaemolysed cells in the suspension was obtained by centrifuging 3 mls of the suspension in a Bauer-Schenk haematocrit tube at 100 x g for 15 minutes and reading off the volume of the packed cells. The degree of haemolysis was determined by measuring the haemoglobin in the supernatant fluid. ³ The K lost from the cells during the haemolysis procedure was obtained by measuring the K content of the supernatant fluid by means of an EEL Flame Photometer.

Fig. 28. The Effect of Ca upon the Amount of K Released from Red Cells at Various Stages of Haemolysis

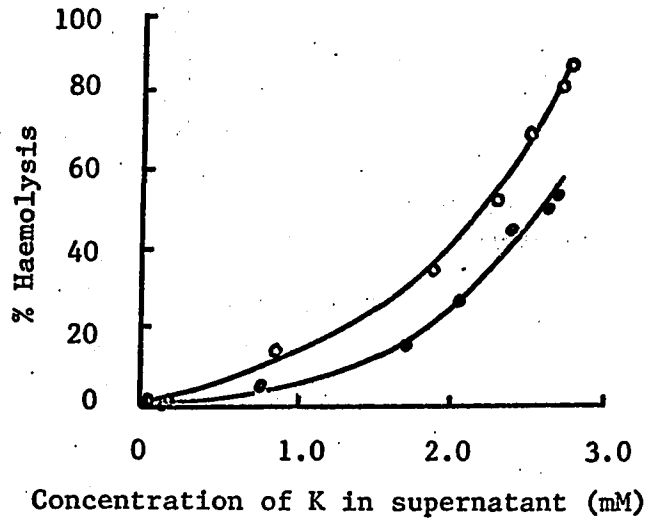

Data taken from Table XXIV. (o) control (●) Ca present

Fig. 29. The Effect of Ca upon the Relationship between the Amount of Haemolysis and the Packed Volume of the Cell Suspension

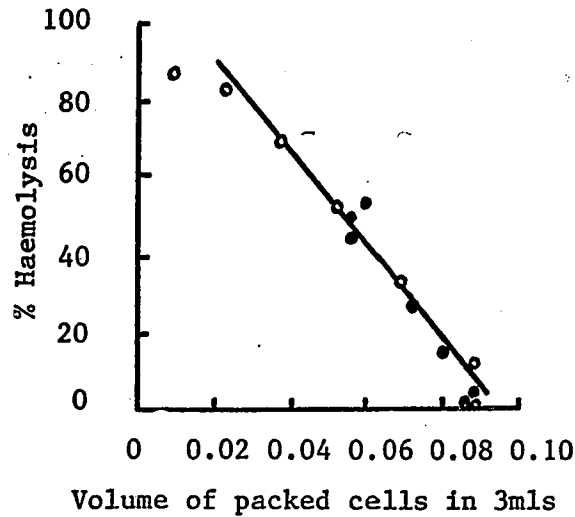

Data taken from Table XXIV. Only data in which the cells have reached or passed their critical haemolytic volume are plotted. (o) control (●) Ca present.

Table XXV. The Effect of Valinomycin upon the Osmotic Haemolysis and Mean Cell Volume of Erythrocytes

% NaCl solution	Control		Control + 10^{-5} M Valinomycin*	
	% haemolysis	MCV μ^3	% haemolysis	MCV μ^3
1.00	0	101	1.0	80
0.60	0	172	1.2	96
0.55	10	188	2.5	94
0.40	100	165	4.0	100

Experimental conditions - the red cell suspensions (an approximately 50% haematocrit in 1% buffered saline) were incubated at room temperature for 3 hours in the presence and absence of 10^{-5} M Valinomycin*. The Valinomycin was added as a methanolic solution in a volume 1/100th of the cell suspension. An equal volume of methanol was added to the control suspension. After incubation 200 μ l of cell suspension was mixed with 4 ml of buffered saline of the required tonicity and the mean cell volume of a 1 in 100,000 suspension of the cells in 1% buffered saline was immediately obtained by means of a cell volume computer attached to a Coulter Counter. The degree of haemolysis was obtained by the haemoglobin method.

*The Valinomycin was kindly donated by Dr T.C.MacDonald, Prairie Research Laboratories, Saskatoon, Saskatchewan.

Valinomycin is known to produce a selective K loss from red cells with a consequent reduction in cell volume (86). As can be seen in Table XXV, these changes markedly inhibit the susceptibility to osmotic lysis of cells exposed to Valinomycin. The effect of Valinomycin upon the critical haemolytic volume of the cells is not known since even at 0.4% NaCl solution, only 4% lysis had occurred.

It was not possible to correlate the cell count obtained in the Coulter Counter with the degree of lysis since the total count changed little over the tonicity range used (presumably both erythrocytes and ghosts were being counted at the settings used: 50 μ aperture, lower threshold of 10, upper threshold of 100, aperture current set at 1/APC = 2, amplitude set at 1/AMP = 1, and the gain trim = 50). However, a count of a mixture of ghosts and erythrocytes in 1% saline was not found to be additive when compared to the individual counts of the two types of cells in the same medium (87).

SECTION III

A Comparison of Erythrocyte Membrane ATP-ase and Erythrocyte Membrane Phosphatase

This section contains a comparison of the ATP-ase and phosphatase activity of erythrocyte membrane to try and establish whether or not the properties of the phosphatase are compatible with its proposed role as a part of the ATP-ase system and thus the cation transport mechanism.

Both phosphatase and ATP-ase activities are located in the membrane of the red cell. The effect of prolonged washing of the prepared membranes upon these two activities can be seen in Fig. 30. These particular membranes were actually fragmented ghosts, having been previously exposed to a buffer of low osmolarity (less than 10 mOsm). Washing produces a rapid loss of membrane protein accompanied by a loss of both phosphatase and ATP-ase activity. The percentage loss of activity was the same for both activities over this washing period. It is also noteworthy that the two components of each type of activity are lost at the same rate. Fig. 31 shows that when intact ghosts prepared in 30 mOsm and 60 mOsm buffers are washed in water, the disruption of the ghosts is accompanied by a small increase in activity.

The effect of Mg ions upon the ATP-ase and phosphatase activity of red cell ghosts is shown in Fig. 32 and 33, respectively. The presence of Mg is mandatory for ATP-ase activity, whereas a significant amount of phosphatase activity is present even in its absence. The phosphatase activity which

Fig. 30. The Effect of Washing upon the ATP-ase and Phosphatase Activity of Red Cell Ghosts

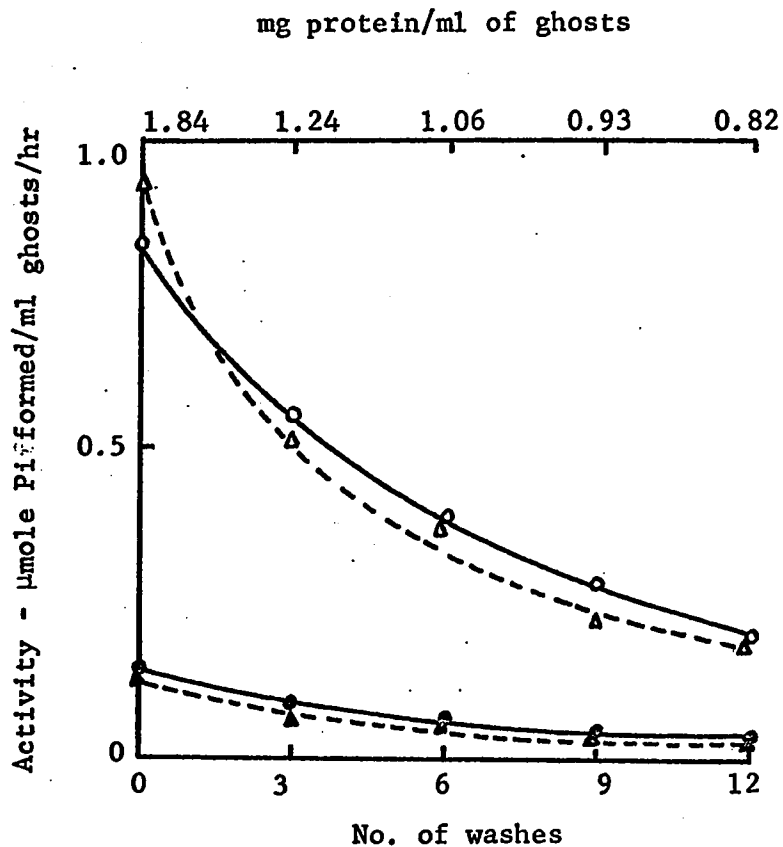

The ghosts were washed the requisite number of times in 20 vols. of a solution containing 4.5 mM TES, pH 7.4, and then the residue made up to the original volume of the cells. (o) OI-ATP-ase activity (Δ) OS-ATP-ase activity - assayed in Na 100 mM, K 16 mM, Mg 3 mM, ATP (Tris) 12 mM, TES 30 mM, pH 7.4. (●) Mg-activated phosphatase activity (▲) K-activated phosphatase activity, assayed in K 10 mM, Mg 7 mM, PNPP (Tris) 3.8 mM, TES 30 mM, pH 7.4. Phosphatase activity expressed as μmole Pi formed/ml ghosts/hr although actually measured as μmole PNP formed.

Fig. 31. The Effect of Washing upon the ATP-ase Activity of 'Intact' Red Cell Ghosts

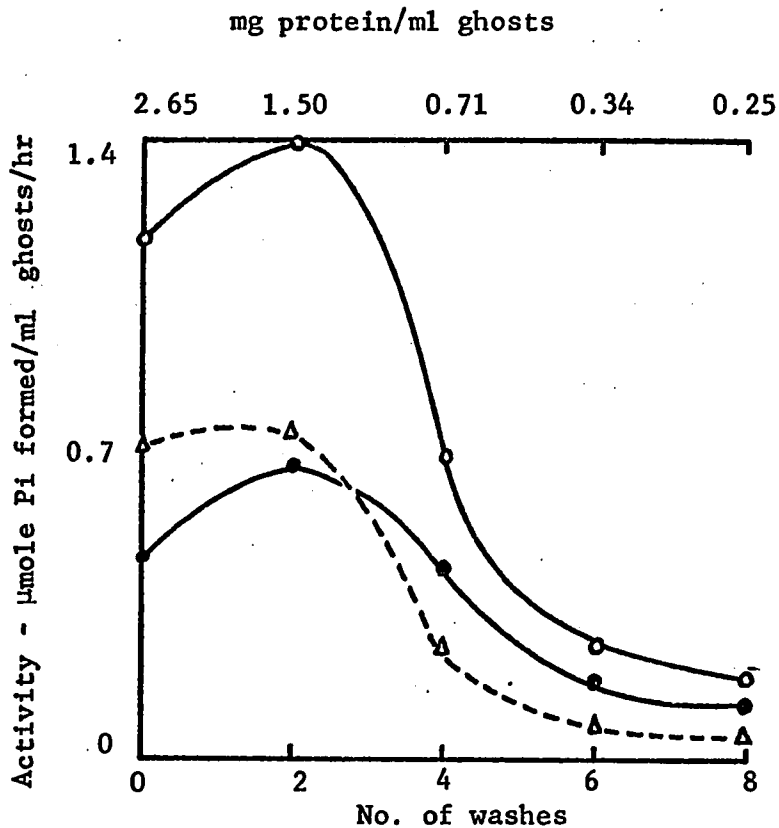

Assay conditions - Na 100 mM, K 16 mM, Mg 3 mM, ATP 2 mM, TES 90 mM, pH 7.4. (o) total ATP-ase activity (●) ouabain 0.5 mM (Δ) difference between the curves representing the OS-activity. The ghosts were washed the requisite number of times in 20 vol. of a solution containing 20 mg Tris/750 ml pH 7.4 and the residue made up to the original volume of the cells.

Fig. 32. The Effect of Mg Concentration upon the ATP-ase Activity of Red Cell Ghosts

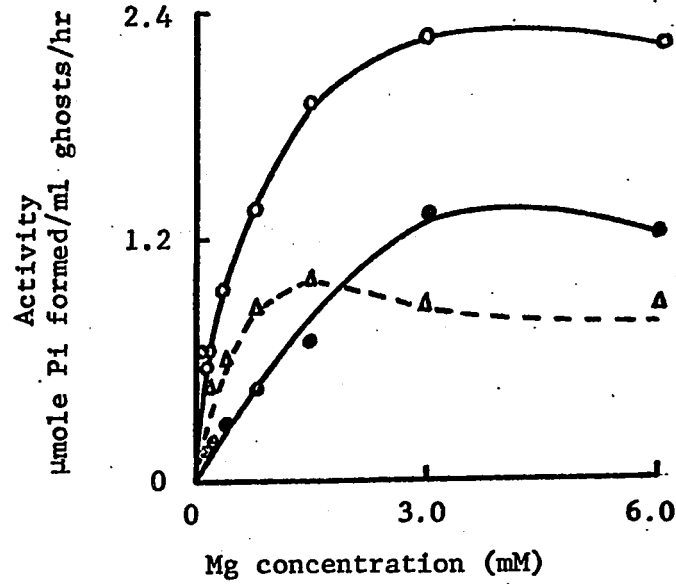

Assay conditions - 100 mM, K 16 mM, ATP 2 mM, TES 30 mM, pH 7.4. (o) glycoside absent (●) ouabain 0.5 mM (Δ) the difference between the two curves representing the ouabain-sensitive component.

Fig. 33. The Effect of Mg Concentration upon the Phosphatase Activity of Red Cell Ghosts

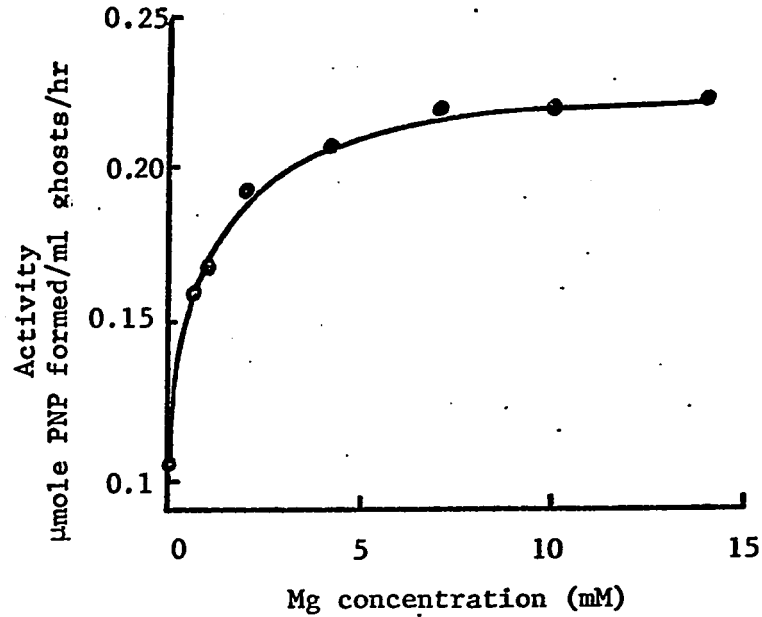

Assay conditions - PNPP 5 mM, TES 30 mM, pH 7.4.

was present in the absence of Mg was activated about 40% by small concentrations of EDTA (0.17 mM).

Both ATP-ase and phosphatase activity are activated by K ions. The ATP-ase is activated by K ions, however, only when Na is also present; in the absence of Na, the activity remains at the basic Mg-dependent level. The phosphatase activity is activated by K alone in the absence of Na. The activation of ATP-ase and phosphatase activity by K can be seen in Figs. 34 and 35, respectively. The K_m of K for the ATP-ase reaction under optimal conditions is about 1.3 mM, although the K_m value is very dependent upon the Na:K ratio, rather than upon the absolute amount of either ion. The K_m of the phosphatase reaction is of a similar magnitude, 4.0 mM.

The effect of Na upon ATP-ase and phosphatase activity can be seen in Figs. 36 and 37, respectively. Only the ATP-ase is activated by Na ions, but K ions must also be present to obtain activation. In the absence of K, the activity remains at the basic Mg-dependent level. In contrast, the phosphatase activity is inhibited at all Na concentrations, complete inhibition of the K-dependent activity (the difference between the activity occurring in the presence of K + Mg and that in the presence of Mg alone) occurring at about 100 mM Na. The basic Mg-dependent phosphatase activity is also susceptible to inhibition by Na.

The cardiac glycoside ouabain completely inhibits the activation of the ATP-ase by Na plus K and also the activation of the phosphatase by K. In both cases, the activity is

Fig. 34. The Effect of K Concentration upon the ATP-ase Activity of Red Cell Ghosts

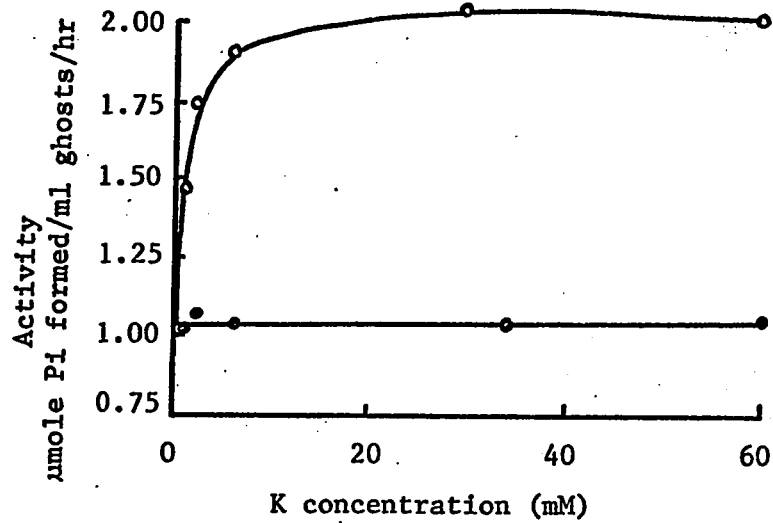

Assay conditions - Na 100 mM, Mg 3 mM, ATP 2 mM, TES 30 mM, pH 7.4.
(o) glycoside absent (●) ouabain 0.5 mM.

Fig. 35. The Effect of K Concentration upon the Phosphatase Activity of Red Cell Ghosts

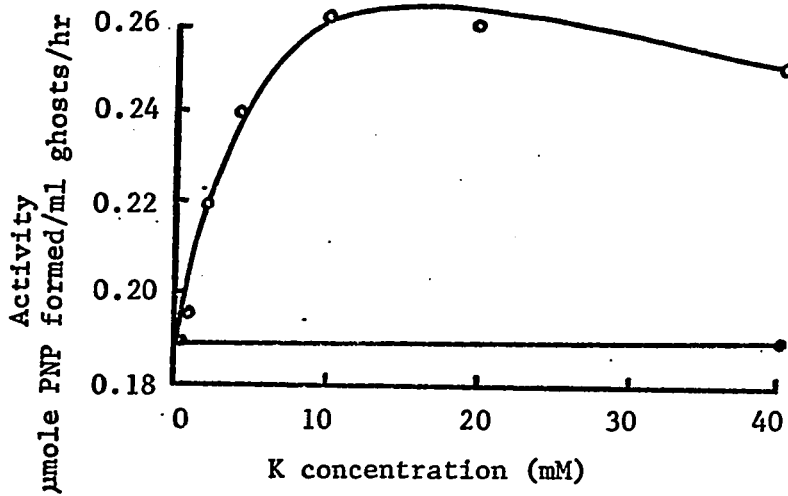

Assay conditions - Mg 7 mM, Tris-PNPP 5 mM, TES 30 mM, pH 7.4.
(o) K present (●) Mg alone.

Fig. 36. The Effect of Na Concentration upon the ATP-ase Activity of Red Cell Ghosts

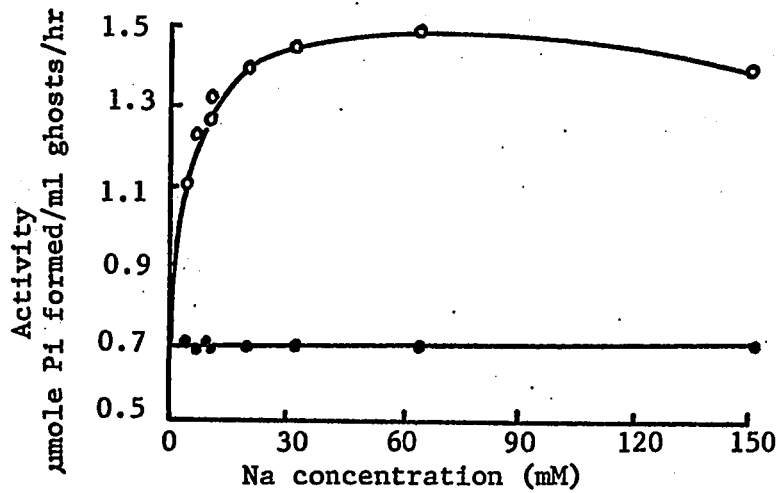

Assay Conditions - K 16 mM, Mg 3 mM, Tris-ATP 2mM, TES 30 mM, pH 7.4. (o) glycoside absent (●) ouabain 0.5 mM.

Fig. 37. The Effect of Na Concentration upon the Phosphatase Activity of Red Cell Ghosts

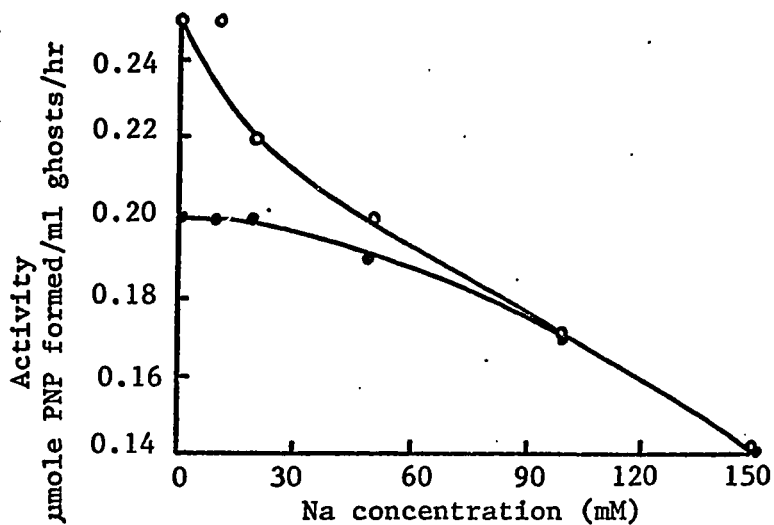

Assay Conditions - K 10 mM, Mg 7 mM, Tris-PNPP 5 mM, TES 30 mM, pH 7.4. (o) K present (●) K absent.

lowered to the level obtained in the presence of Mg ions alone (Figs. 38 and 39). The slight difference between the activity in the presence of Mg alone and that in the presence of high concentrations of ouabain is probably due to traces of Na and K in the medium. However, the ATP-ase and phosphatase differ in their susceptibility to ouabain, the ATP-ase reaction being more readily inhibited than the phosphatase, as can be seen from their respective K_i values of 2×10^{-7} M and 10^{-5} M.

The effect of Ca ions upon the enzyme activities can be seen in Figs. 40 and 41. Both enzymes are inhibited by the presence of small concentrations of Ca. The OI-ATP-ase is markedly stimulated before being inhibited, whereas the OS-ATP-ase is inhibited at all Ca concentrations. No stimulation of the Mg-dependent phosphatase activity by Ca was observed, both components of phosphatase activity being inhibited at all Ca concentrations. The OS-ATP-ase and the K-dependent phosphatase were very similar in their susceptibility to Ca, the Mg-dependent phosphatase activity, however, remained very resistant to inhibition by Ca, even at concentrations of 100 mM.

Fluoride is a little known, yet potent inhibitor of red cell ATP-ase and phosphatase activity. Its effects have therefore been investigated in a little more detail. The effect of NaF upon the ATP-ase activity of red cell ghosts can be seen in Fig. 42. Complete inhibition of activity was obtained with 1.0 mM NaF under the 'usual' assay conditions,

Fig. 38. The Effect of Ouabain upon the ATP-ase Activity of Red Cell Ghosts

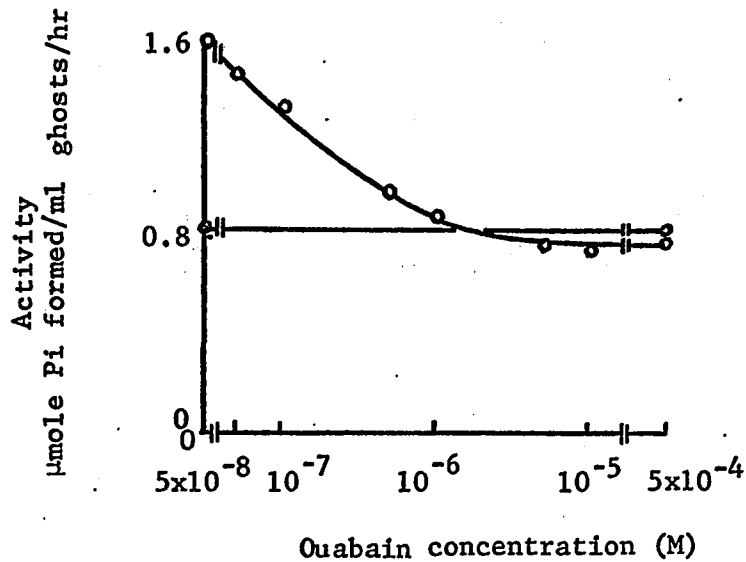

Assay conditions - Na 100 mM, K 16 mM, ATP 2 mM, TES 30 mM, pH 7.4. (o) Total activity (●) Na + K absent. Semi-log scale.

Fig. 39. The Effect of Ouabain upon the Phosphatase Activity of Red Cell Ghosts

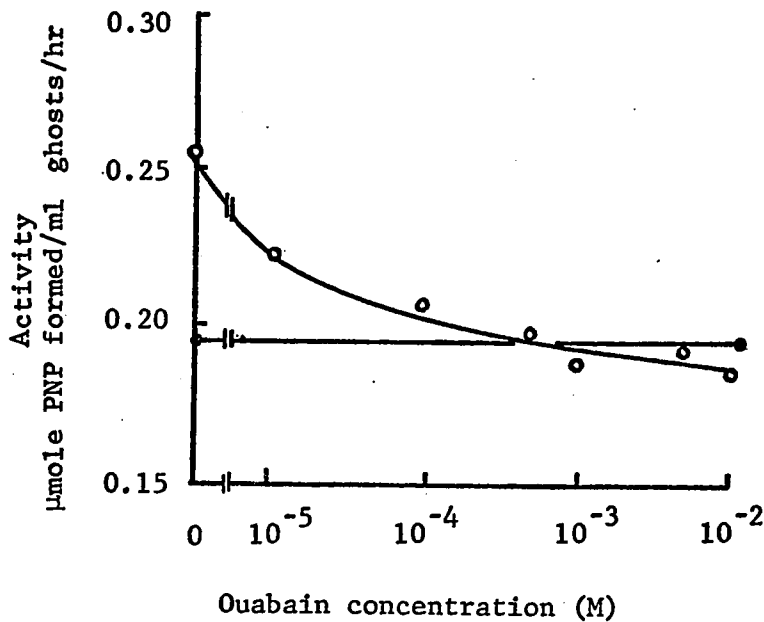

Assay conditions - K 10 mM, Mg 7 mM, PNPP 5 mM, TES 30 mM, pH 7.4. (o) K present (●) K absent. Semi-log scale.

Fig. 40. The Effect of Calcium upon the ATP-ase Activity of Red Cell Ghosts

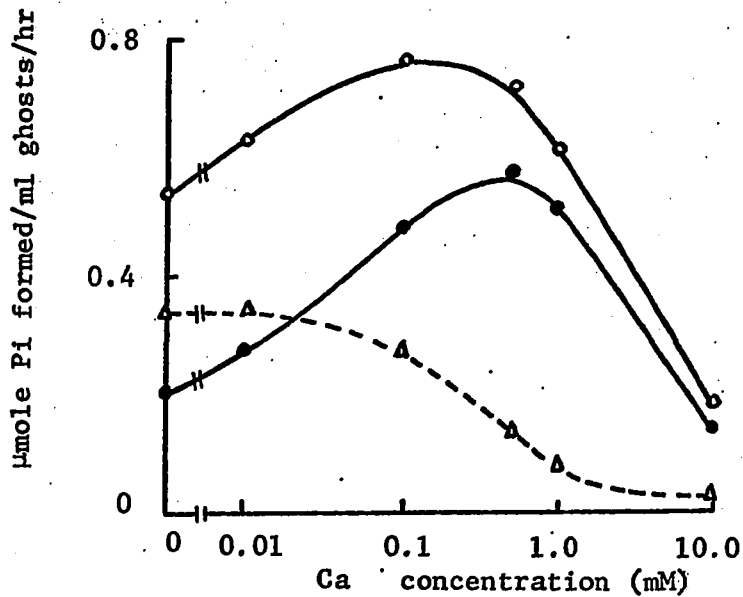

Assay conditions - Na 100 mM, K 16 mM, Mg 4 mM, ATP 2 mM, TES 30 mM, pH 7.4. (o) glycoside absent (●) ouabain 0.5 mM (Δ) the difference between the two curves representing ouabain-sensitive activity. Semi-log scale.

Fig. 41. The Effect of Calcium upon the Phosphatase Activity of Red Cell Ghosts

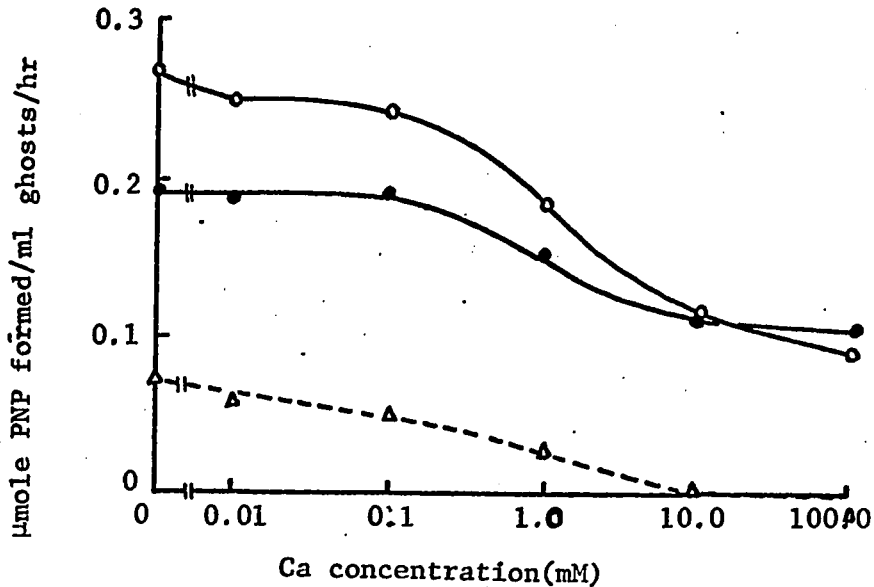

Assay conditions - K 10 mM, Mg 7.0 mM, PNPP 5 mM, TES 30 mM, pH 7.4. (o) K present (●) K absent (Δ) difference between the two curves representing the K-activated component. Semi-log scale.

but as will be seen later, this is dependent upon the Mg concentration. As is the case with many ATP-ase inhibitors, the OS-component is the most readily inhibited.

Fig. 43 shows the effect of Mg concentration upon the amount of inhibition produced by a constant amount of NaF. Only a small amount of inhibition is observed when the concentrations of ATP and Mg are the same, i.e. at 2.0 mM, but a marked increase in the degree of inhibition occurs as the Mg concentration is increased. The effect is particularly marked in the case of the OS-component. A similar effect is observed when the ATP concentration is decreased, increasing the concentration of free Mg (Table XXVI). When the Mg:ATP ratio is less than one, little inhibition occurs (Table XXVII.) The presence of NaF did not affect the estimation of activity by phosphate determination since the same degree of inhibition was obtained when the activity was determined as ADP formed.

In contrast to its effect on enolase (88,89), the presence of phosphate does not appear to affect the amount of inhibition produced by NaF (Table XXVIII). Calcium also has little effect upon the inhibitory power of NaF, though only low concentrations of Ca could be used because of the inhibition produced by calcium itself (Table XXIX). High concentrations of fluoride which have a marked effect upon the cation permeability of red cells (90,91,92) do not appear to have a permanent effect upon the ATP-ase activity of the membrane. In one experiment, the ghosts were incubated for 30 minutes at 37°C in the presence of 40 mM NaF. After dialysing free of NaF,

Fig. 42. The Effect of NaF upon the ATP-ase Activity of Red Cell Ghosts

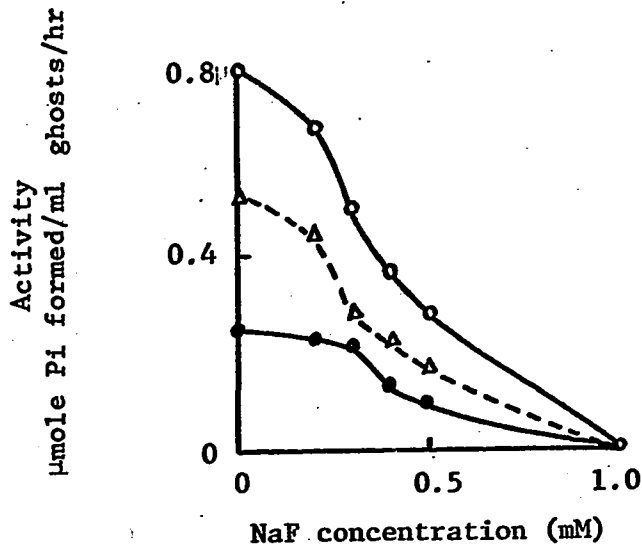

Assay conditions - Na 100 mM, K 16 mM, Mg 3 mM, ATP 2 mM, TES 30 mM, pH 7.4. (o) glycoside absent (●) ouabain 0.5 mM (Δ) the difference between the two curves representing the ouabain-sensitive component.

Fig. 43. The Effect of Mg Concentration upon the Inhibition of Red Cell Ghost ATP-ase by NaF

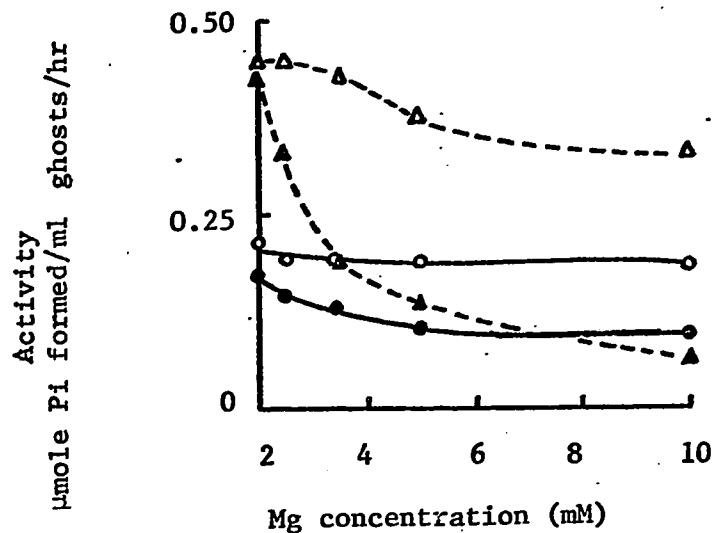

Assay conditions - Na 100 mM, K 16 mM, ATP 2 mM, TES 30 mM, pH 7.4. (Δ) OS-activity in the absence of NaF (▲) OS-activity in the presence of 0.3 mM NaF (o) OI-activity in the absence of NaF (●) OI-activity in the presence of 0.3 mM NaF.

Table XXVI. The Effect of Lowering the ATP Concentration Below the Mg Concentration upon the Inhibition of Red Cell Ghost ATP-ase Activity by 0.3 mM NaF

	0.5 mM ATP:3.0 mM Mg			2.0 mM ATP:3.0 mM Mg		
	Control	NaF 0.3 mM	% inhibition	Control	NaF 0.3 mM	% inhibition
Total	0.56	0.28	50	0.76	0.56	27
OI	0.19	0.12	32	0.24	0.18	27
OS	0.37	0.15	58	0.52	0.38	26

Assay conditions - Na 100 mM, K 16 mM, Mg 3 mM, ATP 2 or 0.5 mM, TES 30 mM, pH 7.4. 0.5 mM ouabain added to obtain the OI-activity.
Activity - umole Pi formed/ml ghosts/hr.

Table XXVII. The Effect of Lowering the Mg Concentration Below the ATP Concentration upon the Inhibition of Red Cell Ghost ATP-ase Activity by 0.3 mM NaF

	Mg 0.5 mM:ATP 2.0 mM			Mg 2.0 mM:ATP 2.0 mM		
	Control	NaF 0.3 mM	% inhibition	Control	NaF 0.3 mM	% inhibition
Total	0.51	0.51	0	0.82	0.76	8
OI	0.12	0.10	11.0	0.30	0.26	14
OS	0.39	0.41	0	0.52	0.50	5

Assay conditions - Na 100 mM, K 16 mM, Mg 0.5 and 2.0 mM, ATP 2 mM, TES 30 mM, pH 7.4. 0.5 mM ouabain added to obtain the OI-activity.

Table XXVIII. The Effect of Added Phosphate upon the Amount of Inhibition by 0.3 mM NaF of Red Cell Ghost ATP-ase Activity

	Control	Control + NaF 0.3 mM	% inhibition	Pi 0.33 mM		
				Control	Control + NaF	% inhibition
Total	0.71	0.53	25	0.67	0.49	27
OI	0.21	0.16	25	0.21	0.16	24
OS	0.50	0.37	25	0.46	0.33	27

Assay conditions - Na 100 mM, K 16 mM, Mg 3 mM, ATP 2 mM, TES 30 mM, pH 7.4, 0.5 mM ouabain added to obtain the OI-activity.

Table XXIX. The Effect of Ca upon the Amount of Inhibition Produced by 0.3 mM NaF of Red Cell Ghost ATP-ase Activity

	Control	NaF	% inhibition	Ca 0.05 mM		
				Control	NaF	% inhibition
Total	0.65	0.50	24	0.78	0.61	22
OI	0.17	0.13	22	0.35	0.28	20
OS	0.48	0.36	24	0.43	0.33	23

Assay conditions - Na 100 mM, K 16 mM, Mg 3 mM, ATP 2 mM, TES 30 mM, pH 7.4; 0.5 mM ouabain added to obtain the OI-activity

the ATP-ase activity was the same as the control value.

Like the ATP-ase, the phosphatase activity of red cell ghosts is also inhibited by NaF, although the latter enzyme is not as readily inhibited as the ATP-ase (Fig. 44). However, as in the case of the ATP-ase, the inhibition has a more marked effect upon the K-sensitive component than upon the Mg-sensitive component. In contrast to the ATP-ase, raising the Mg concentration produces little increase in the degree of inhibition by NaF (Table XXX).

There is a marked difference between the optimal pH for ATP-ase activity and that for phosphatase activity (Figs. 45 and 46). All components of the ATP-ase have an optimum pH between 7.4 and 8.2, whereas the components of the phosphatase have an apparent optimum of pH 6.0. A slight rise in the activity of the cation-independent phosphatase above pH 9 was observed.

If, as has been suggested, the phosphatase activity represents the terminal reaction in the ATP-ase cycle, it is reasonable to expect a competitive inhibition of the ATP-ase by the presence of p-nitrophenyl phosphate and, conversely, a competitive inhibition of the phosphatase by the presence of ATP. Table XXXI and Fig. 47 show the results of one such experiment in which ATP-ase activity was measured in the presence and absence of PNPP. One aliquot of each reaction mixture was used for a phosphate determination and a second aliquot of the same reaction mixture was assayed for PNP. The ATP-ase activity was thus obtained by subtracting the amount

Fig. 44. The Effect of NaF upon the Phosphatase Activity of Red Cell Ghosts

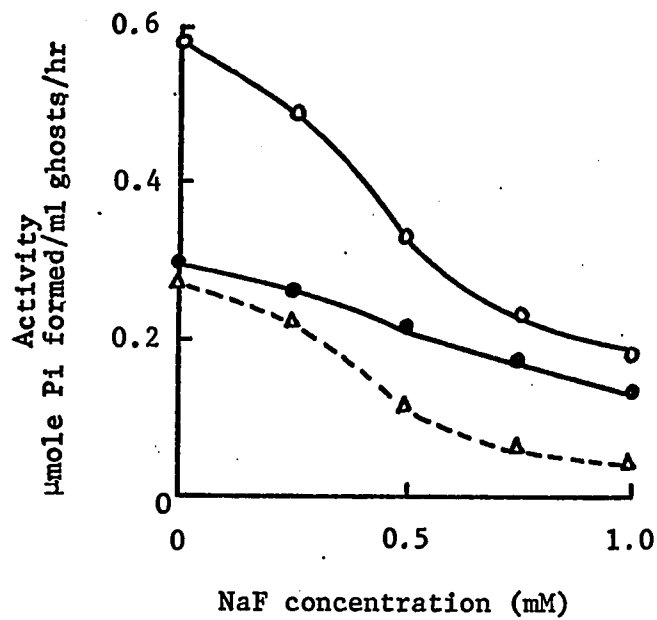

Assay conditions - K 16 mM, Mg 3 mM, Tris-PNPP, 2.5 mM, TES 30 mM, pH 7.4 (o) K present (●) K absent (Δ) the difference between the two curves representing the K-sensitive component.

Table XXX. The Effect of Mg Concentration upon the Inhibition of Red Cell Ghost Phosphatase Activity by NaF

Activity	Mg 3.0 mM	Mg 15.0 mM	Mg 23.0 mM
Control	0.58	0.59	0.54
Control + 0.5 mM NaF	0.33	0.30	0.28
% inhibition	44	49	48

Activity - μ mole PNP formed/ml cells/hr

Assay conditions - K 16 mM, Tris-PNPP 2.5 mM,

TES 30 mM, pH 7.4.

Fig. 45. The Effect of pH upon the ATP-ase Activity of Red Cell Ghosts

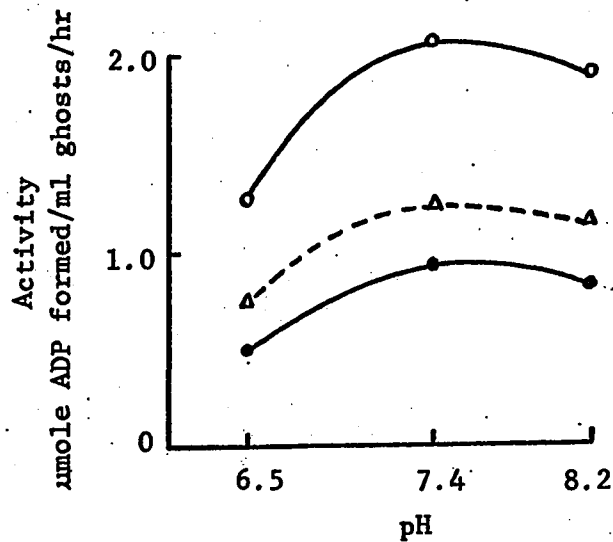

Data taken from Fig. 23. (o) glycoside absent (●) ouabain 0.1 mM (Δ) difference between the two curves representing the ouabain-sensitive activity. Each point indicates the maximum activity obtained at that pH (Fig. 23.)

Fig. 46. The Effect of pH upon the Phosphate Activity of Red Cell Ghosts

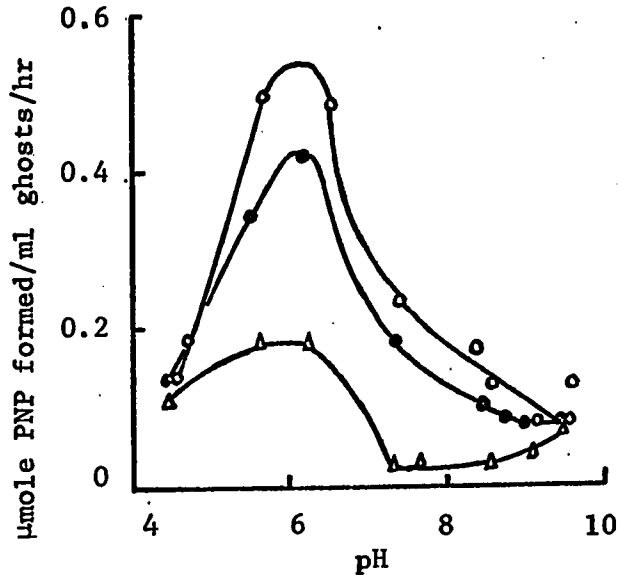

Assay conditions - Mg 7 mM, K 10 mM, PNPP 5 mM. Buffers - pH 5-6 = MES; 7-8 = TES; >8 = Tris. (o) Mg + K present (●) K absent (Δ) Mg + K absent

Table XXXI. The Effect of PNPP upon the ATP-ase Activity of Red Cell Ghosts

ATP mM	0.1mM	0.1mM +PNPP	0.2mM	0.2mM +PNPP	0.4mM	0.4mM +PNPP	0.8mM	0.8mM +PNPP
Total ATP-ase	0.28	0.18	0.43	0.24	0.61	0.44	0.78	0.55
OI - ATP-ase	0.16	0.20	0.20	0.17	0.30	0.32	0.34	0.42
OS - ATP-ase	0.12	0	0.23	0.07	0.31	0.12	0.44	0.13

Activity = μ mole Pi formed/ml cells/hr. Assay conditions - Na 80 mM, K 16 mM, Mg 3 mM, TES 30 mM, pH 7.4, where necessary PNPP 20 mM, 0.5 mM ouabain added to obtain the OI-ATP-ase activity.

Fig. 47. Inhibition of Red Cell Total ATP-ase Activity by PNPP

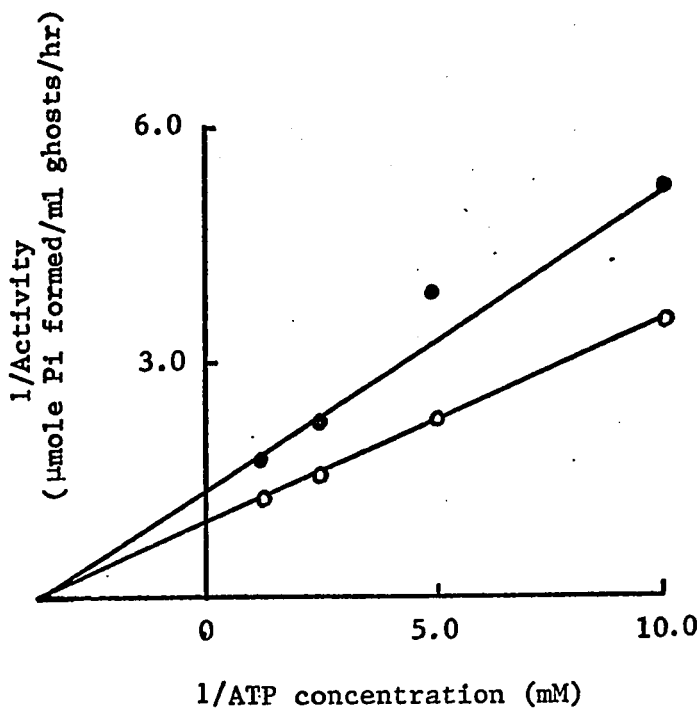

Assay conditions - Na 80 mM, K 16 mM, Mg 3 mM, TES 30 mM, pH 7.4
 (o) PNPP absent (●) PNPP 20 mM.

of PNP released from the amount of phosphate formed. An inhibition of ATP-ase activity in the presence of PNPP was indeed observed. However, it was not found possible to obtain data to which all components of the ATP-ase could be readily subjected to Lineweaver-Burk analysis, due perhaps to the small differences in activity obtained and to the high concentrations of PNPP needed to obtain a significant inhibition of the ATP-ase.

The phosphatase is much more susceptible to inhibition by ATP than the ATP-ase by PNPP. Analysis of the effect of ATP upon phosphatase activity (Fig. 48) indicates a non-competitive inhibition of phosphatase activity under the conditions of the experiment.

Fig. 49 shows the effect of thermal denaturation of the ghosts upon their ATP-ase and phosphatase activity. The ghosts were suspended in the reaction mixture containing Na, K and Mg but no ATP, and heated to the desired temperature for a short period. The suspension was then cooled to 37°C, ATP or PNPP added, and the ATP-ase and phosphatase activities were measured in the usual manner.

The amount of inactivation of any particular temperature was the same using periods of heating between three and ten minutes. The two components of the ATP-ase respond differently to thermal denaturation; the OI-component is much more readily inactivated by heat than the OS-component, especially over the initial portion of the curve. The curves for the inactivation of total ATP-ase activity and phosphatase activity

Fig. 48. Inhibition of Phosphatase Activity of Red Cell Ghosts by ATP

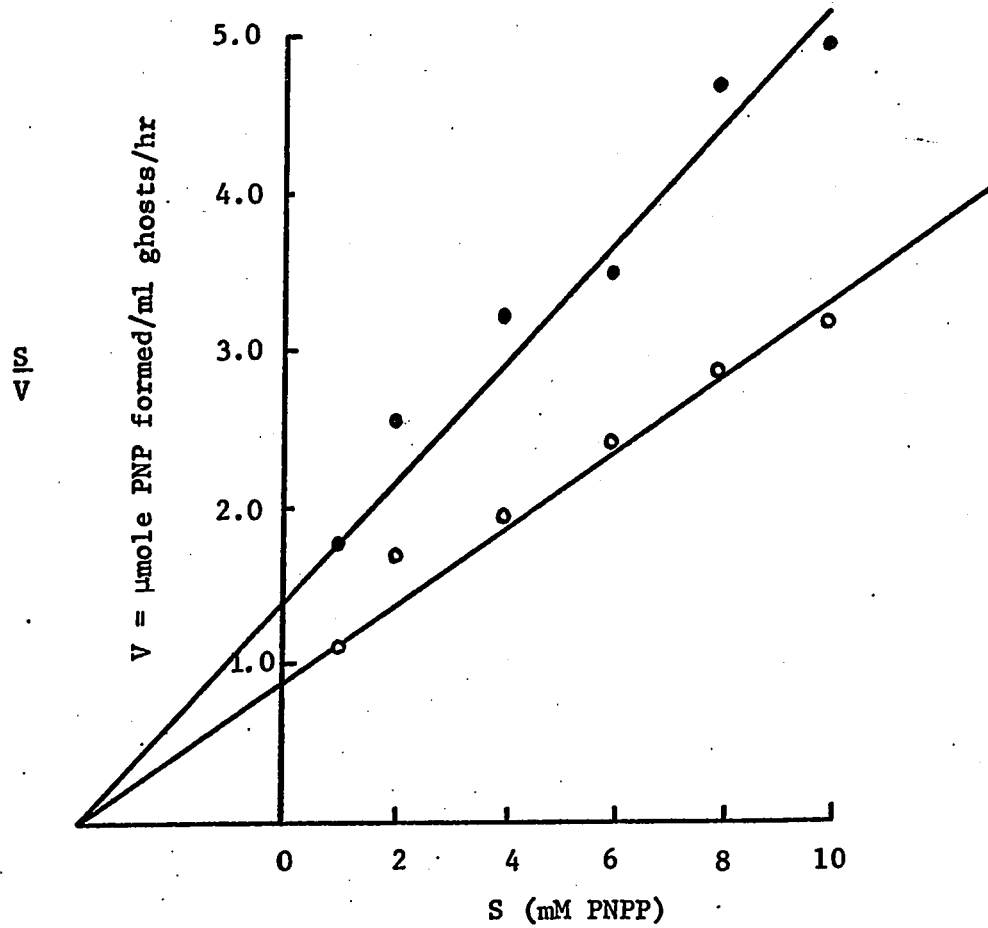

Assay conditions - Na 100 mM, K 16 mM, Mg 2 mM, Tris 20 mM, pH 7.4.
(o) PNPP alone (●) PNPP + 1.0 mM ATP.

Fig. 49. The Effect of Heat on the ATP-ase and Phosphatase Activity of Red Cell Ghosts

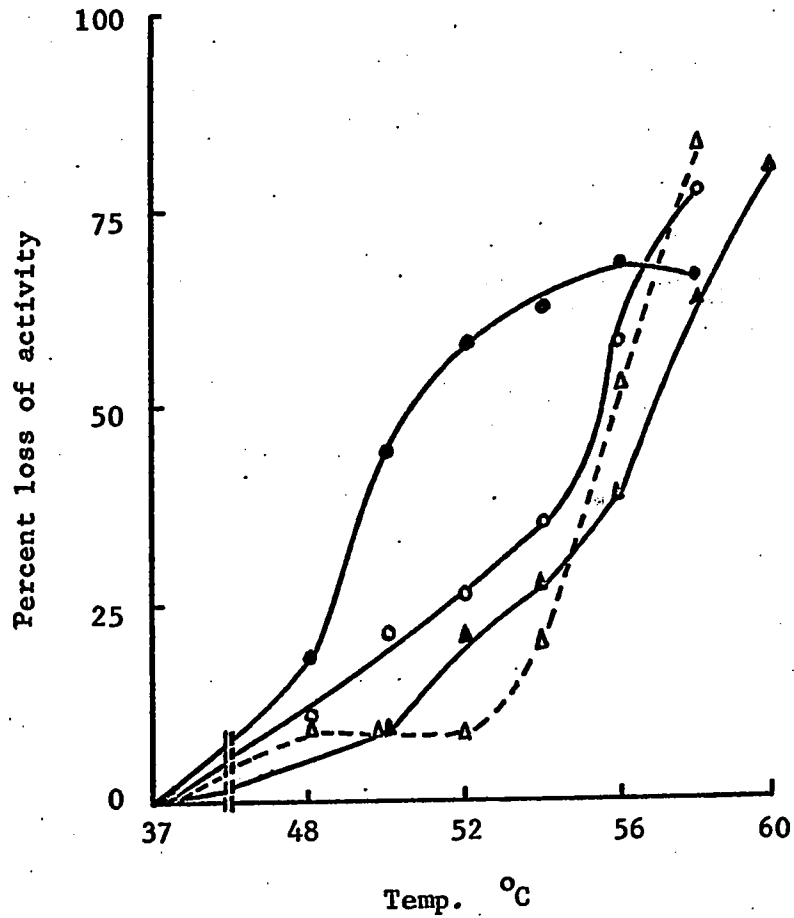

ATP-ase assay conditions - Na 100 mM, K 16 mM, Mg 3 mM, ATP 2 mM, TES 30 mM, pH 7.4. (o) glycoside absent (●) ouabain 0.5 mM (Δ) ouabain-sensitive component.

Phosphatase assay conditions - Na 100 mM, K 16 mM, Mg 3 mM, PNPP 10 mM (Na₂), TES 30 mM, pH 7.4. (Δ) phosphatase activity

were almost identical in shape but not in position. The amount of inactivation of the ATP-ase at any given temperature was somewhat higher than that of the phosphatase. Small amounts of calcium were found to increase the thermal inactivation of the ATP-ase activity (Table XXXII).

Figs. 50 and 51 show the dependence of ATP-ase and phosphatase activity upon temperature. The Arrhenius plot for the total ATP-ase activity (22 - 46°C) consists of two straight lines which intersect at about 37°C ($1/T \times 10^3 = 3.22$). The experimental activation energies calculated from the plot were 27 kcals/mole and 14 kcals/mole at the low and high temperatures, respectively. The plot for the OS-ATP-ase had a break at 37°C, with experimental activation energies for the high and low temperature regions of 13 kcals/mole and 36 kcals/mole, respectively. Both the OI-ATP-ase and the phosphatase (22 - 40°C) had straight line Arrhenius plots with a similar activation energy of 15 kcals/mole.

Table XXXII. The Effect of Heat in the Presence of Ca on the ATP-ase Activity of Red Cell Ghosts

Activity - μ mole/ml/hr	Total Activity	OI	OS
Control	1.10	0.67	0.43
Heated Control (51°/5 mins)	0.33	0.12	0.21
% loss of activity	70	82	53
Control + 0.01 mM Ca	1.44	0.96	0.48
Control + 0.01 mM Ca + heat	0.25	0.09	0.76
% loss of activity	82	91	65
Control + 0.2 mM Ca	1.99	1.70	0.29
Control + 0.2 mM Ca + heat	0.17	0.06	0.11
% loss of activity	91	96	63

Assay conditions - Na 100 mM, K 16 mM, Mg 3 mM, ATP 2 mM, TES 30 mM, pH 7.4. 0.5 mM ouabain added to obtain the OI-activity.

Fig. 50. Arrhenius Plot for the ATP-ase Activity of Red Cell Membranes.

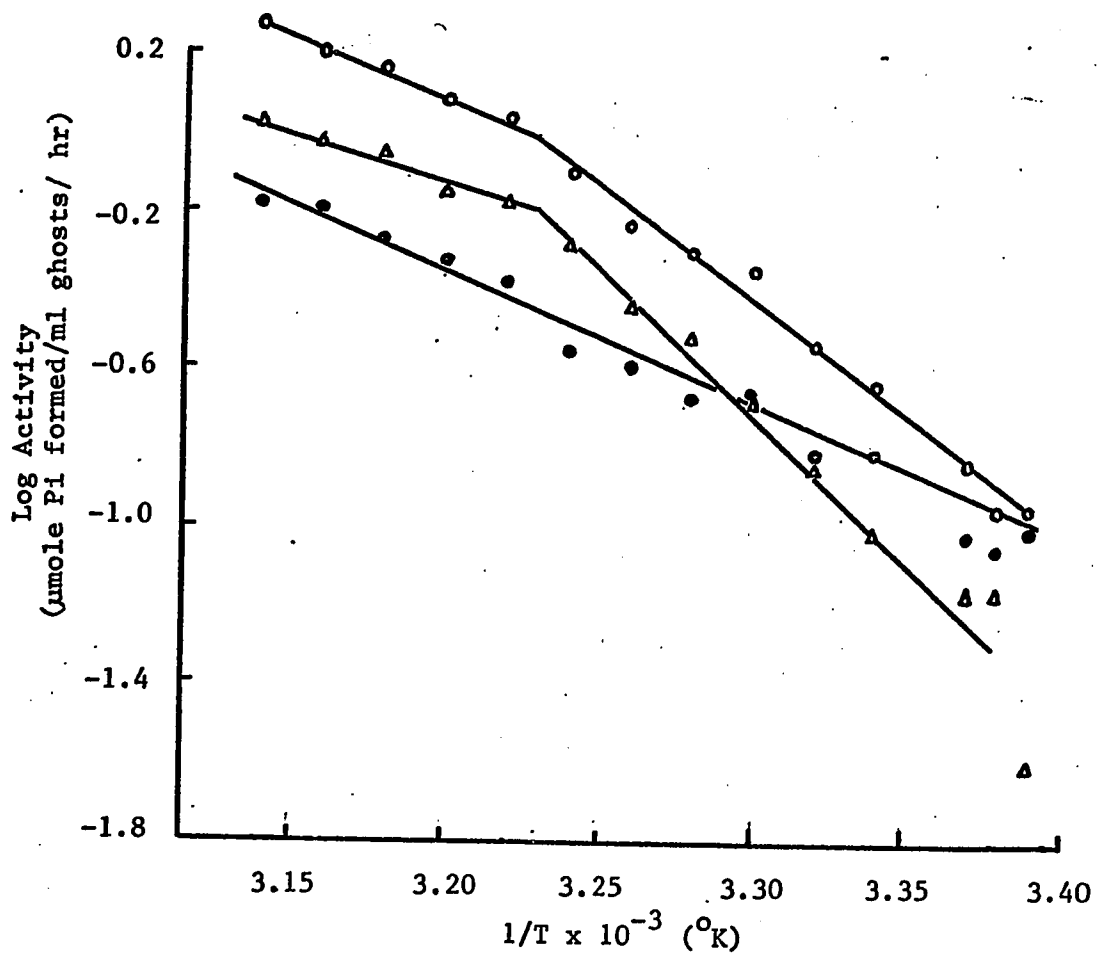

Assay conditions - Na 100 mM, K 16 mM, Mg 3 mM, ATP 2 mM, TES 30 mM, pH 7.4. (o) glycoside absent (●) ouabain 0.5 mM (Δ) ouabain-sensitive component.

Fig. 51. Arrhenius Plot for the Phosphatase Activity of Red Cell Membranes

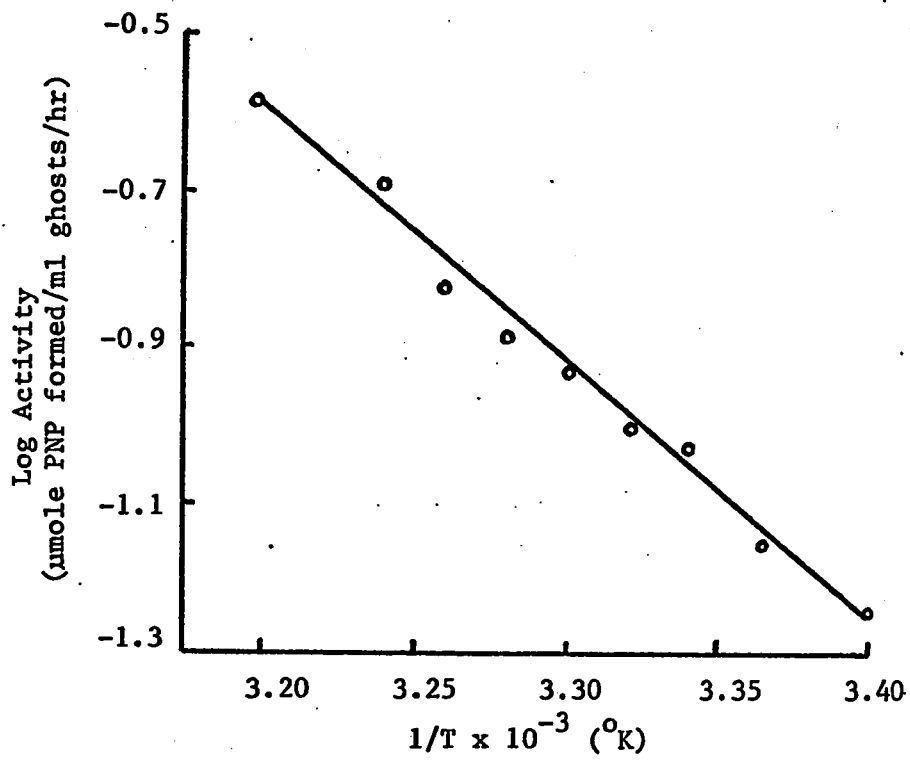

Assay conditions - Na 100mM, K 16 mM, Mg 3 mM, PNPP 5mM, TES 30 mM, pH 7.4.

SECTION IV

Solubilisation of Erythrocyte Membrane ATP-ase Activity. The Effect of Certain Detergents and Organic Reagents upon the Properties of the ATP-ase.

In an attempt to obtain a soluble preparation of erythrocyte membrane ATP-ase, ghosts were treated with the organic solvent n-butanol and the detergents sodium lauryl sulphate, Tween 20, and Triton X-100. In conjunction with these solubilisation experiments, the effect of these agents, all of which dissociate lipoprotein complexes of cell membranes, upon the properties of the ATP-ase system were investigated. The effect of urea, dioxane, dimethyl sulphoxide, and ethylene glycol, organic reagents capable of unfolding polypeptide chains and of activating myosin ATP-ase, upon the ATP-ase activity of red cell ghosts were also investigated.

The detergents sodium lauryl sulphate, Tween 20, and Triton X-100, and n-butanol all had a qualitatively similar effect upon the properties of the ATP-ase, namely an activation of the OI-ATP-ase at low concentrations followed by an inhibition at higher concentrations (Figs. 52-55). Tween 20 was an exception in producing an activation of the OS-component. Ca, which also activates the OI-component, seems to show some slight synergism with SLS with respect to this component (Fig. 56). In the presence of both Ca and SLS, each at concentrations which produce less than maximal stimulation of the OI-component, the activation is greater than either produces alone (Fig. 56A). No effect upon the OS-component was observed at these concentrations. At higher

Fig. 52. The Effect of Tween 20 upon the ATP-ase Activity of Red Cell Ghosts

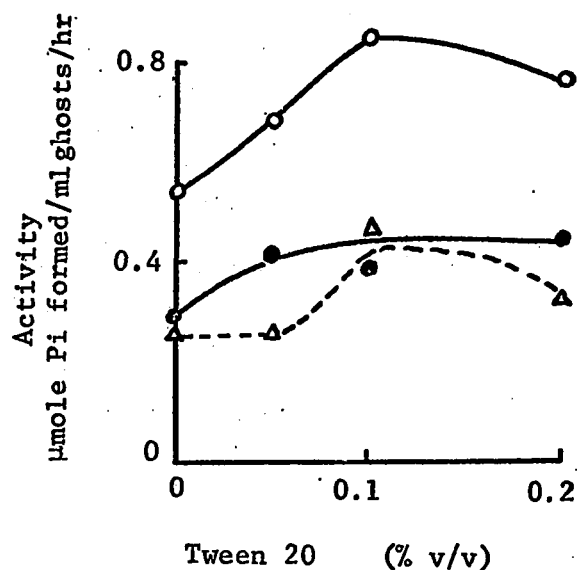

Assay conditions - Na 100 mM, K 16 mM, Mg 3 mM, ATP 2 mM, HEPES 100 mM, pH 7.4 (o) glycoside absent (●) ouabain 0.5 mM (Δ) the difference between the two curves representing the ouabain-sensitive component.

Fig. 53. The Effect of Triton X-100 upon the ATP-ase Activity of Red Cell Ghosts

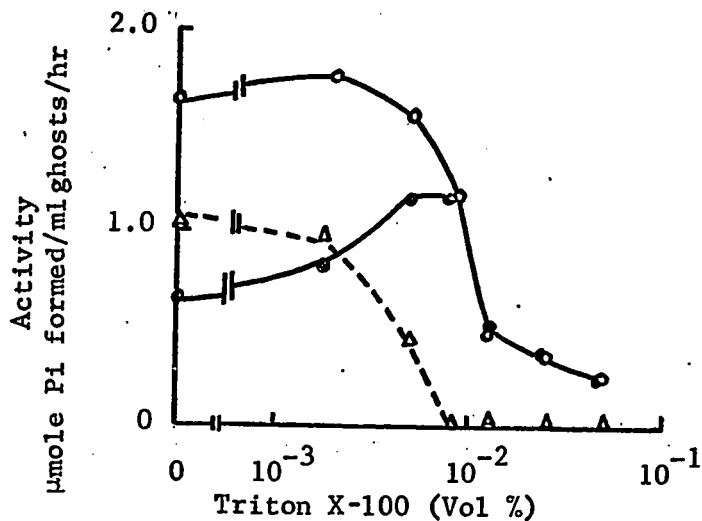

Assay conditions - Na 100 mM, K 16 mM, Mg 3 mM, Tris-ATP 2 mM, TES 30 mM, pH 7.4 (o) glycoside absent (●) ouabain 0.5 mM (Δ) the difference between the curves representing the ouabain-sensitive component.

Fig. 54. The Effect of Sodium Lauryl Sulphate upon the ATP-ase Activity of Red Cell Ghosts

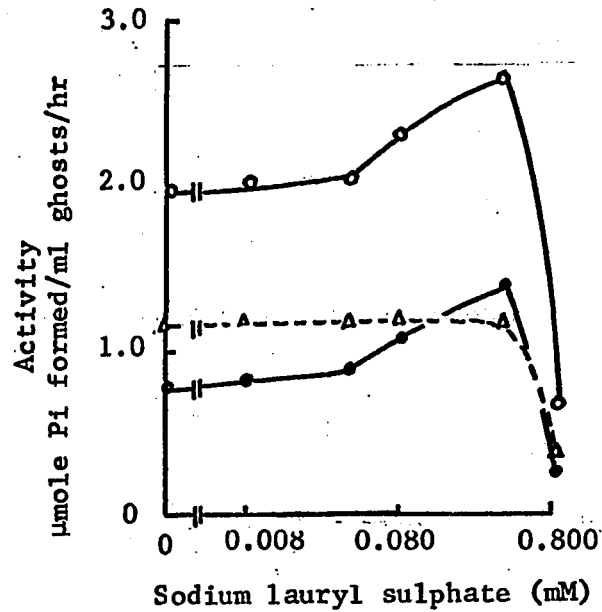

Assay conditions - Na 77 mM, K 12.4 mM, Mg 1.54 mM ATP 2 mM, Tris 32.4 mM, pH 7.4. (o) glycoside absent (●) ouabain 0.1 mM (Δ) the difference between the two curves representing the ouabain-sensitive component. Semi-log scale.

Fig. 55. The Effect of Butanol upon the ATP-ase Activity of Red Cell Ghosts

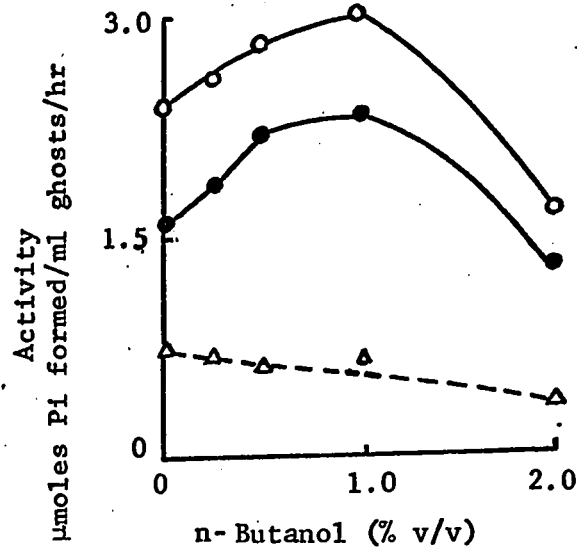

Assay conditions - Na 100 mM, K 16 mM, Mg 3 mM, Tris-ATP 2 mM, TES 30 mM, pH 7.4. (o) glycoside absent (●) ouabain 0.5 mM (Δ) the difference between the two curves representing the ouabain-sensitive component.

Fig. 56. The Effect of Ca in the Presence of SLS upon the ATP-ase Activity of Red Cell Ghosts

A.

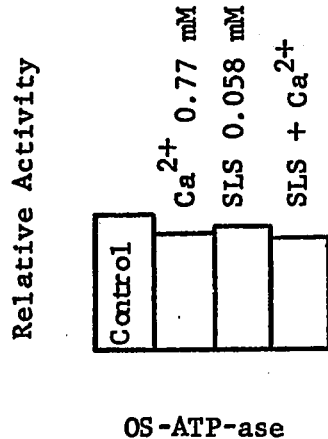
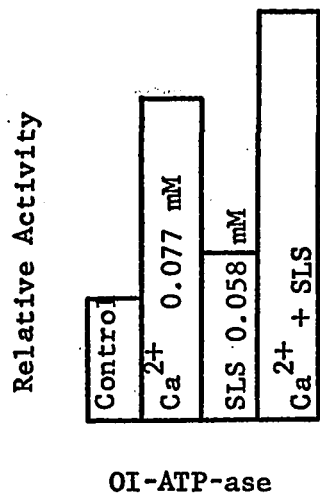

B.

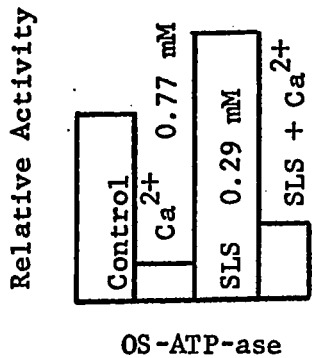
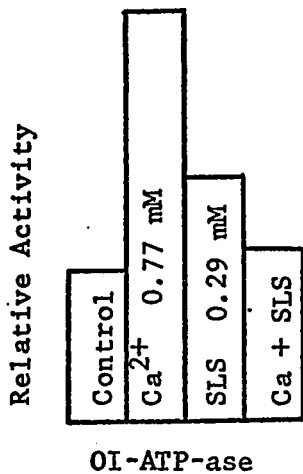

Assay conditions - Na 16 mM, K 16 mM, Mg 2 mM, ATP 2 mM, Tris 18.2 mM, pH 7.4, 0.1 mM ouabain added to obtain the OI-activity.

concentrations, close to those at which each agent alone produces optimal stimulation, the activation in the presence of both is almost negligible (Fig. 56B). The activation of the OS-component by SLS at the higher concentration is not regarded as significant; other data (see Fig. 54) do not indicate an activation of this component by SLS.

Attempts to use n-butanol with Morton's procedure to obtain a soluble preparation of the enzyme were unsuccessful. However, Weed (93) has recently reported obtaining a soluble ATP-ase using a butanol procedure. However, loss of cation sensitivity accompanied the procedure. The ghosts could be readily solubilised with SLS, but only at concentrations which resulted in complete loss of ATP-ase activity. An attempt was made to obtain a soluble preparation with this detergent by incubating the ghosts overnight in the presence of SLS at concentrations which produced an activation of the OI-component. It was hoped that the membrane structure might be loosened and the soluble enzyme liberated. However, only the residue contained ATP-ase activity, no activity being present in the supernatant (Table XXXIII). In contrast to the activation of the OI-component previously observed, the activity of this component in the residue was now greatly decreased whilst the OS-activity previously unaffected by this concentration of SLS now had a greater activity. The net result was a large increase in the OS:OI ratio.

A soluble preparation of the ghosts which retained some ATP-ase and phosphatase activity was obtained using the non-

Table XXXIII. The Effect of Prolonged Exposure of Red Cell Ghosts to SLS Upon the ATP-ase Activity of the Ghosts

Expt.	Conc'n of SLS	OI-Activity μmole Pi formed/ml cells/hr	OS-Activity	Ratio $\frac{OS}{OI}$
1	None	0.44	0.44	1.0
	3.85×10^{-4} M	0.26	0.78	3.0
2	None	0.77	0.47	0.6
	3.85×10^{-4} M	0.10	0.59	5.9
3	None	0.34	0.13	0.4
	2.5×10^{-4} M	0.08	0.30	3.8

The ghosts were preincubated for approximately twenty hours at 37°C in a medium containing 77 mM Na, 12.4 mM K, 1.54 mM Mg, 32.4 mM Tris, pH 7.4. The suspension was then centrifuged, the supernatant removed, and the residue made up to the original volume of ghost added. A control suspension not containing SLS was treated similarly. The ATP-ase activity of the residue was assayed in a medium containing 77 mM Na, 12.4 mM K, 1.54 mM Mg, 32.4 mM Tris, pH 7.4, ATP 2 mM; 0.1 mM ouabain added to obtain the OI-activity.

ionic detergent Triton X-100 as indicated in Table XXXIV. However, the ATP-ase was no longer sensitive to cations after dialysing the ghosts free of detergents. Dialysis itself reduced the activity of the ghosts as can be seen in Table XXXV, but increased the OS:OI ratio, possibly through the removal of traces of Ca which can activate the OI-component.

The effects of urea, dioxane, dimethyl sulphoxide and ethylene glycol, each of which is capable of altering protein conformation, was in some respects similar to those of the detergents and n-butanol, though their effect was not so marked.

The effects of urea upon the ATP-ase activity of red cell ghosts can be seen in Fig. 57. Urea, a reagent with strong H-bond-forming tendencies, and thought to unfold polypeptide chains by disruption of hydrophobic bonds, caused a slight activation of the OI-ATP-ase at about 0.5 M concentration followed by an inactivation of both components at higher concentration. The effects of dioxane are similar to those of urea as can be seen in Fig. 58. Dioxane readily forms peroxides upon storage which might contribute to its effect upon the ATP-ase activity.

Dimethyl sulphoxide, which is finding extensive use as a protective agent in low-temperature storage, produced only inactivation of the ATP-ase, primarily inhibiting the OS-component until concentrations of 30% v/v are used when both components are inhibited (Fig. 59). The effects of DMSO were reversible, at least up to concentrations of 23% v/v; ghosts

Table XXXIV. Solubilization of Ghost ATP-ase with Triton X-100

TX-100% v/v	Control (untreated cells)	0.0063%	0.0125%	0.025%
ATP-ase activity (μ mole Pi formed/mg protein/hr)	OS = 0.44 OI = 0.18	0.05	0.07	0.08
Phosphatase activity (μ mole Pi formed/mg protein/hr)	-	0.01	0.04	0.03
mg protein/ml of supernatant from TX-100 suspension	1.43	0.60	0.72	0.92

The ghosts were suspended in TX-100 solution of the appropriate strength and the suspension centrifuged at 9000 rpm/15 mins. The supernatant was dialysed against 5 mM MES, pH 6.0, containing 20 mg GSH/litre at 0°C until removal of TX-100 was achieved. The dialysed supernatant was then assayed for ATP-ase and phosphatase activity in a medium containing Na 100 mM, K 16 mM, Mg 3 mM, TES 30 mM, pH 7.0, ATP 2 mM or PNPP 5 mM (Tris salt). 0.5 mM ouabain added to obtain the OI-activity.

Fig. 57. The Effect of Urea upon the ATP-ase Activity of Red Cell Ghosts

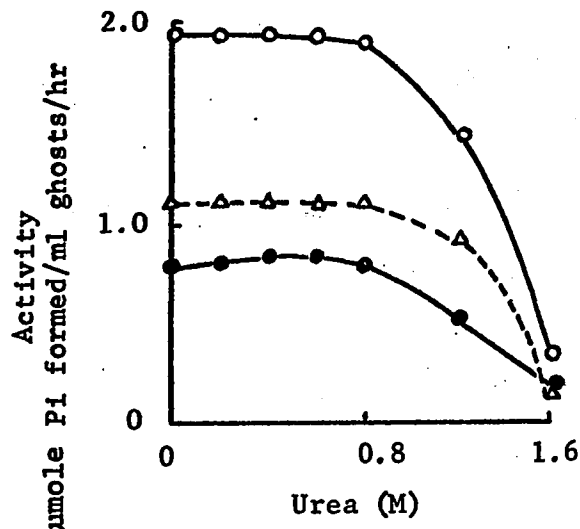

Assay conditions - Na 77 mM, K 12.4 mM, Mg 1.54 mM, ATP 2 mM, Tris 32.4 mM, pH 7.4.
(o) glycoside absent (●) ouabain 0.1 mM
(Δ) the difference between the two curves representing the ouabain-sensitive component.

Fig. 58. The Effect of Dioxane upon the ATP-ase of Red Cell Ghosts

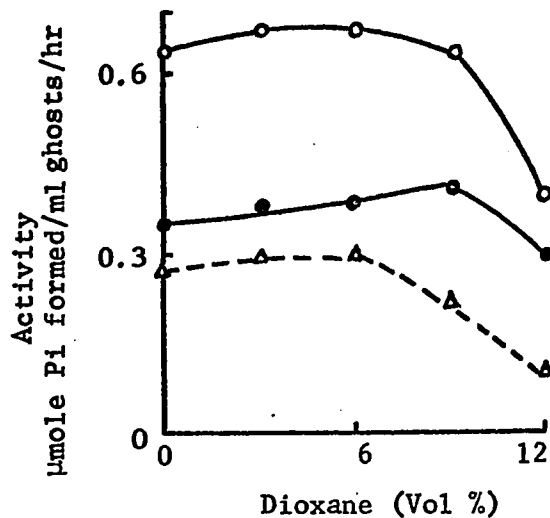

Assay conditions - Na 77 mM, K 12.4 mM, Mg 1.54 mM, ATP 2 mM, Tris 32.4 mM, pH 7.4. (o) glycoside absent (●) ouabain 0.1 mM (Δ) the difference between the two curves representing the ouabain-sensitive component.

exposed to DMSO and then washed free of this reagent had the same activity as ghosts not exposed to DMSO. A reversible action of DMSO is a necessary prerequisite to its use as a preservative agent.

A substantial activation of the OI-component was produced by ethylene glycol at concentrations of 30% v/v followed by a reduction in activity (Fig. 60) at higher concentrations. The OS-component was inhibited at all concentrations. This reagent preferentially disrupts hydrophobic regions of protein molecules, but is essentially equal to water in hydrogen-bond forming tendencies.

Fig. 59. The Effect of Dimethyl Sulphoxide upon the ATP-ase Activity of Red Cell Ghosts

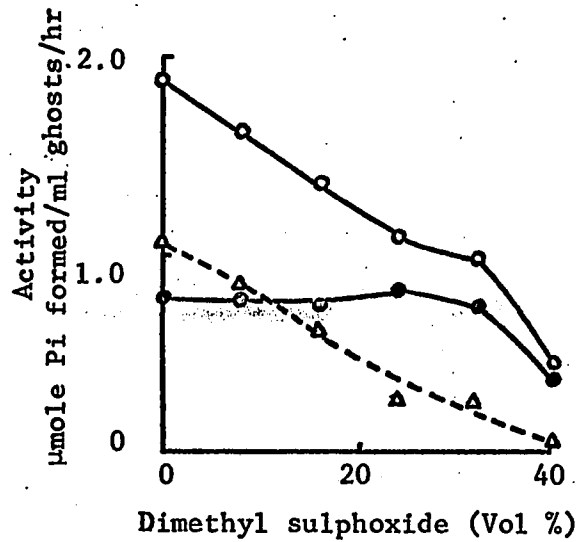

Assay conditions - Na 77 mM, K 12.4 mM, Mg 1.54 mM, ATP 2 mM, Tris 32.4 mM, pH 7.4 (o) glycoside absent (●) ouabain 0.1 mM (Δ) the difference between the two curves representing the ouabain-sensitive component.

Fig. 60. The Effect of Ethylene Glycol upon the Activity of Red Cell Ghosts

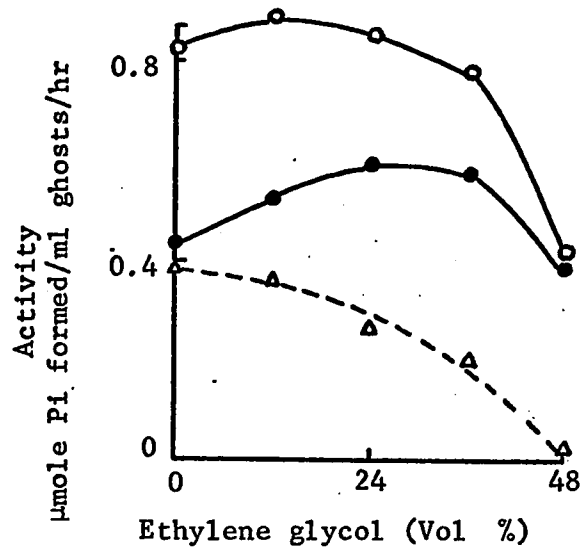

Assay conditions - Na 77 mM, K 12.4 mM, Mg 1.54 mM, ATP 2 mM, Tris 32.4 mM, pH 7.4 (o) glycoside absent (●) ouabain 0.1 mM (Δ) the difference between the two curves representing the ouabain-sensitive component.

SECTION V

The Effect of Miscellaneous Inhibitors Upon Erythrocyte Membrane ATP-ase Activity

Nearly all of the glycosides which have cardiotonic activity and which inhibit the Na-K activated ATP-ase contain a carbonyl oxygen in conjugation with a carbon-carbon double bond located in the side chain (94,95). This conjugated system has been suggested to be the effective group, producing an inhibition of the ATP-ase by H-bonding to the hydroxyl group of the phosphoric acid residue in the phosphorylated intermediate, thus preventing the final K-dependent dephosphorylation step. Other components having a carbonyl oxygen in conjugation with a carbon-carbon double bond were tested as inhibitors of the Na-K activated ATP-ase, and many of them had this property even though there was no resemblance in structure among them except for the conjugated system (95). The erythropleum alkaloids were found to be as potent as the cardiac glycosides in this respect (97). Brown (96,97) has recently found that certain azasteroids which contain the cyclopentanophenanthrene nucleus, but no β oriented lactone ring or the previously mentioned conjugated system common to most cardiac glycosides, were potent inhibitors of the Na-K activated ATP-ase. Like the cardiac glycosides, the inhibition by these steroids was reduced by increasing the K concentration.

The following compounds also containing a carbonyl oxygen in conjugation with a carbon-carbon double bond were

tested here as ATP-ase inhibitors; ethacrynic acid (2,3-dichloro(2-methylene-butyryl)-phenoxy acetic acid)*, o-phthal-dialdehyde, dimethyl and dibutyl phthalate, and spironolac-tone.†

Ethacrynic acid, one of the new diuretic drugs, was found to inhibit red cell ATP-ase activity but, unlike the cardiac glycosides, is not specific for the Na-K activated ATP-ase (Fig. 61). Duggan (98) found this compound to inhibit kidney-cortex ATP-ase. The amount of inhibition increases with the period of preincubation with this drug (Table XXXVI). O-phthaldialdehyde is a potent inhibitor of ATP-ase activity, complete inhibition of the OS-component occurring at concentrations less than 10^{-4} M (Fig. 62). This compound appears to block sulphhydryl groups since the inhibition is relieved by the presence of GSH (Table XXXVII). Once inhibition has occurred, however, the action appears to be irreversible (Table XXXVIII). Dimethyl phthalate did not act as an inhibitor but in fact activated the ATP-ase (Table XXXIX). Dibutyl phthalate at a concentration of 1 mM produced an activation of the OI-component. Spironolactone, a steroid containing a carbonyl oxygen in conjugation with a carbon-carbon double bond in the cyclopentanophenanthrene ring and a saturated γ -lactone ring, was found to be inhibitory at concentrations up to 1.0 mM. The simple saturated γ -lactone butyrolactone has previously been shown to inhibit ion transport in high concentrations.

*Gift from Merck Institute, Pennsylvania.

†Gift from G. D. Searle and Co., Ltd., Ontario.

Fig. 61. The Effect of Ethacrynic Acid upon the ATP-ase Activity of Red Cell Ghosts

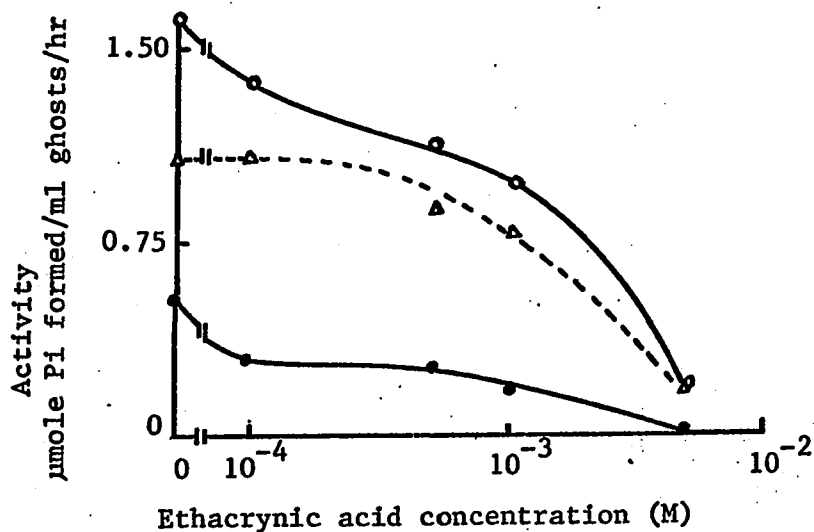

Assay conditions - Na 100 mM, K 16 mM, Mg 2mM, ATP 2mM, Tris 20 mM, pH 7.4. (o) glycoside absent (●) ouabain 0.1 mM, (Δ) the difference between the two curves representing the ouabain-sensitive component. Semi-log scale.

Fig. 62. The Effect of Phthaldialdehyde upon the ATP-ase Activity of Red Cell Ghosts

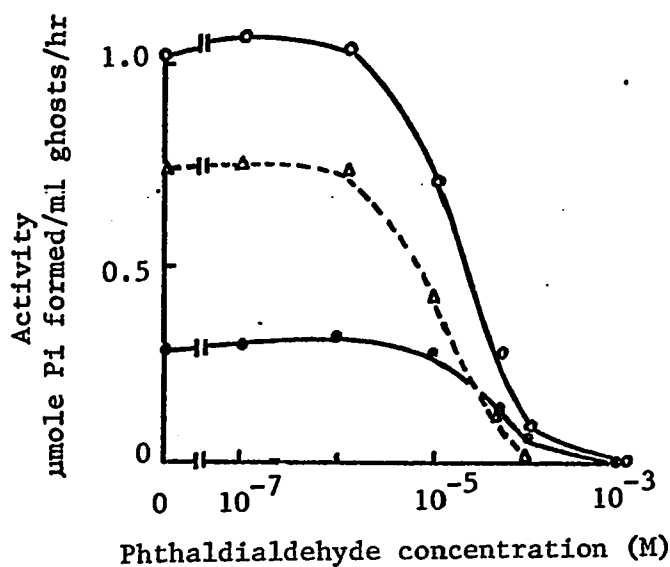

Assay conditions - Na 100 mM, K 16 mM, Mg 2mM, ATP 2 mM, Tris 20 mM, pH 7.4. (o) glycoside absent (●) ouabain 0.1 mM (Δ) the difference between the two curves representing the ouabain-sensitive component. Semi-log scale.

Table XXXVI. The Effect of the Length of Preincubation of Red Cell Ghosts with Ethacrynic Acid upon their ATP-ase Activity

Mins. of Preincubation	% Inhibition			
	10	20	40	80
Total - ATP-ase	6.3	11.7	18.8	32.5
OI - ATP-ase	6.1	5.0	11.9	23.0
OS - ATP-ase	5.9	22.0	34.8	56.2

The ghosts were preincubated in a medium containing Na 100 mM, K 16 mM, Mg 2 mM, TES 90 mM, pH 7.4, ouabain where necessary 0.1 mM, for the requisite time. The ATP-ase activity was then determined after addition of 2 mM ATP to the medium.

Table XXXVII. The Effect of GSH upon the Inhibition of Red Cell Ghost ATP-ase Activity by O-Phthalaldehyde

Agent Added	% inhibition		
	2.5x10 ⁻⁵ M PDA	2.5x10 ⁻⁵ M PDA + 1.0 mM GSH	5x10 ⁻⁵ M PDA + 1.0 mM GSH
Total-ATP-ase	37	15	34
OI - ATP-ase	27	8	28
OS - ATP-ase	43	20	36

Ghosts were added to a medium containing Na 100 mM, K 16 mM, Mg 2 mM, Tris 20 mM, pH 7.4, 0.1 mM ouabain where necessary and PDA or PDA + GSH and pre-incubated at 37°/10 mins. The ATP-ase activity was then assayed after the addition of 2 mM ATP.

Table XXXVIII. Irreversibility of the Inhibition by O-Phthalaldehyde of Red Cell Ghost ATP-ase Activity

	Control	2.5x10 ⁻⁵ M PDA	2.5x10 ⁻⁵ M PDA + 1.0 mM GSH
Total-ATP-ase	1.53	0.78	0.78
OI - ATP-ase	0.67	0.38	0.40
OS - ATP-ase	0.86	0.40	0.38

µmole Pi formed/ml cells/hr.

Ghosts were preincubated for 60 mins/37° in a medium containing Na 100 mM, K 16 mM, Mg 2 mM, Tris 20 mM, pH 7.4, 0.1 mM ouabain where necessary and PDA. The ghosts were then washed 2x with this cation solution not containing PDA, made up to their original volume, divided into two portions. One portion was incubated with 1.0 mM GSH for 60 mins, the other without GSH. Control cells not exposed to PDA were treated similarly throughout. The ATP-ase activity was then assayed after the addition of ATP (2 mM).

Table XXXIX.. The Effect of Dimethyl Phthalate upon
the ATP-ase Activity of Red Cell Ghosts

Concn. of dimethyl phthalate	0.0mM	0.5mM	1.0mM	5.0mM	10.0mM
Total - ATP-ase	2.76	2.90	2.94	3.31	3.42
OI - ATP-ase	1.01	1.14	1.13	1.09	1.16
OS - ATP-ase	1.75	1.76	1.81	2.22	2.26

μmole Pi formed/ml cells/hr.

Assay medium - Na 114 mM, K 16 mM, Mg 2 mM, ATP 2 mM,
TES 30 mM, pH 7.4, 0.1 mM ouabain where necessary.

The substituted phenothiazine, chlorpromazine, was also found to be quite a potent inhibitor of red cell ATP-ase with a K_i of 3×10^{-4} M with respect to the total ATP-ase (Fig. 63). A similar K_i for the brain enzyme has previously been reported (99). In contrast to a previous report (100) no alleviation of chlorpromazine inhibition was obtained when the K concentration was increased from 0.5 to 13 mM, nor did alteration of the Na concentration affect the amount of inhibition.

In view of the unknown nature of the carrier involved in the ATP-ase reaction, it was of interest to note certain similarities between the movement of carnitine across certain membranes and the ATP-ase system.

Bremer (101) has suggested that carnitine is a carrier of activated acyl groups across the mitochondrial membrane, probably a two-way process, according to the following scheme:

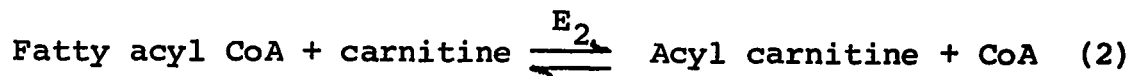
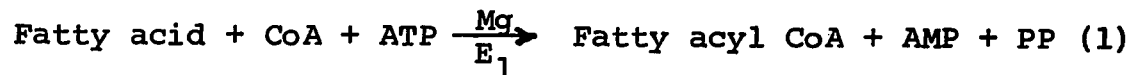

E_1 = Acyl CoA synthetase, E_2 = acyl carnitine-CoA acyl transferase. Recently, the uptake of carnitine into Ps. aeruginosa was found to be stimulated by Mg and by Na plus K, to require metabolic energy, to obey saturation kinetics, and to be inhibited by ouabain, all characteristics of the Na-K transport system (102).

An attempt was therefore made to study the activity of the acyl CoA synthetase-acyl carnitine-CoA transferase system

Fig. 63. The Effect of Chlorpromazine upon the ATP-ase Activity of Red Cell Ghosts

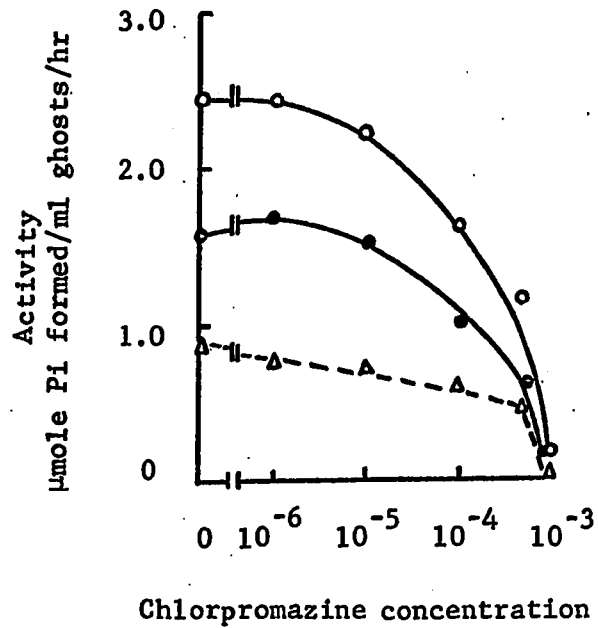

Assay conditions - Na 100 mM, K 16 mM, Mg 3 mM, Tris-ATP 2 mM, TES 30 mM, pH 7.4. (o) glycoside absent (●) ouabain 0.5 mM (Δ) the difference between the two curves representing the ouabain-sensitive activity. Semi-log scale.

in the red cell membrane. The activity of reaction (1) was determined by measuring the decrease in CoA using the method of Ellman (103) and reaction (2) was to be determined by measuring the formation of the acyl carnitine by the procedure of Friedman (104). However, due to the extremely low activity of the enzymes involved, satisfactory estimations of the velocities could not be obtained. The effect of palmitylcarnitine synthesised by the method of Bremer (105) and carnitine, upon the red cell ATP-ase was tried. Palmitylcarnitine had detergent-like properties, producing visible signs of solubilisation of the membrane at concentrations of 1.0 mM. Almost complete inhibition of the OS-component, and 70% inhibition of the OI-component were obtained at this concentration. Lower concentrations appeared to activate the OI-component. Palmityl carnitine has been reported to inhibit cardiac ATP-ase (106). Carnitine itself had little or no effect upon ATP-ase activity.

V. DISCUSSION

The data obtained for the interaction of Na and K with the OS-ATP-ase of the erythrocyte membrane are not consistent with the Michaelis-Menten model previously suggested as applicable to the enzyme and to the active movement of these ions. The interaction may be more adequately described by any of three possible models involving multiple binding sites for Na and K.

The interactions of Na and K with the ATP-ase may be allosteric in nature. Such a model suggests the existence of two or more cooperatively interacting binding sites on the enzyme protein for Na and K. It is not possible to obtain an exact estimate of the number of binding sites for each ligand from the Hill equation since the n value only approximates a theoretically meaningful function which describes the interaction. The value of n is dependent not only upon the number of sites but also upon the nature of their interaction. Only when the interaction between sites is very strong will n coincide with the number of binding sites. Values of n only slightly greater than unity may indicate weak interaction among the binding sites for K. Ouabain did not affect the apparent order of the reaction with regard to K as might have been expected in view of the interaction between the glycosides and K.

The sigmoidal curves obtained for K and for Na activation may also be explained by a mechanism which does not involve an allosteric effect of these ions. It has been

observed that excess Na can decrease the activation by K and excess K the activation by Na (16, 107, 108) (see also Fig. 13 and Table XXI), probably through displacement of one ion species from its binding site by the other. Na and K may be attracted electrostatically to the same binding site if this is perhaps ionic in character, but they would fit differently due to the differences in the size of their hydrated radii. If the enzyme has two or more binding sites for Na, one of which has a lower affinity for the ion than the others, preferential displacement of Na from its weakest binding site by K would produce a sigmoidal Na activation curve. This effect would be most obvious at low Na concentrations and would tend to disappear as the Na concentration is increased, shifting the curve to the left. Similarly raising the fixed K concentration should shift the inflection point and the half-maximal point of activation to the right but would not be expected to change the kinetic order of the reaction with respect to Na. These predictions are in accordance with the observations. The curve for K activation might be explained in exactly the same way assuming that K has two binding sites on the enzyme with different affinities for the K ion. A third possible mechanism by which the data might be explained is the case where Na or K acts as both an activator and a substrate of the system. The ions would act as a substrate in the sense that they are actively transported across the membrane. Such a mechanism would require the presence of two or more Na or K ions simultaneously at some binding sites on the enzyme before the system became operational.

Whilst it is not possible to distinguish between these three mechanisms, the data are consistent with recent kinetic studies of the Na efflux and K influx in whole cells. Hoffman found that in the rat erythrocyte, a plot of Na efflux against extracellular K concentration yielded a sigmoidal curve (61). Similar curves obtained by Sachs (62,63), and by Glynn (64) when they examined the rate of active K influx into human red cells as a function of external K concentration, suggested that the K and Na carriers have more than one site. This is supported by the synergistic effect of Rb described by Sachs and fits in with what is known about the stoichiometry of the pump. Whilst Glynn has applied his data to the second model described here, Sachs has suggested the data may be adequately described by a mechanism in which two K ions are required simultaneously at some binding sites where they could act either as a substrate and an activator or as two substrate molecules.

The cardiac glycoside ouabain appears to interact only with K and not with Na as had been suggested by Schatzmann (67) and by Ahmed (60). At high concentrations of Na relative to K, Na does appear to enhance the inhibition by ouabain. To produce this effect, however, Na must generally be present at concentrations above which it normally activates the enzyme and at concentrations which tend to produce a direct reduction in measurable velocity. It can be seen that the difference between the OS-activity in the presence of inhibition concentrations of Na and the activity in the presence of small amounts of ouabain is constant over the Na range used. This strongly

suggests that in fact ouabain is inhibiting a constant amount of enzyme (i.e., a constant number of active K sites perhaps) at all Na concentrations; and increasing the Na concentration merely reduced the activity of the remaining "ouabain-free" enzyme, producing an apparent increase in the amount of inhibition by ouabain.

The interaction of ouabain with K is indicated by the decreased inhibition of the ghost ATP-ase by ouabain upon raising the K concentration. However, the mode of action of the glycoside upon the ghost ATP-ase does not seem to be identical to its action upon the active movement of Na in whole cells. Lineweaver-Burk plots at a constant Na:K ratio indicate a competitive inhibition of K by ouabain (there is no firm evidence to suggest an interaction between Na and the glycosides). It should be noted that Matsui (66) obtained evidence of non-competitive inhibition of beef heart ATP-ase under similar conditions. However, the action of ouabain may be slightly different in cardiac tissue. Considering how firmly ouabain has been found to bind to whole cells, competitive inhibition with respect to K would not have been expected. However, when the experiments of Hoffman (65), which examined the relationship between the degree of glycoside binding and the presence of K, were repeated here with ghosts, completely different results were obtained. Whereas Hoffman found that the glycosides were indeed bound firmly to whole cells and that prior exposure of the cells to high concentrations of K could prevent this binding, the glycosides

were not found to bind at all firmly to ghosts in this investigation (using ATP-ase activity as an index of glycoside binding). In addition, Hoffman concluded that because Cs, which can be actively transported by erythrocytes, was unable to prevent the glycosides binding, the glycosides must be binding at a site other than the transport site, thereby producing inhibition indirectly. The weak binding of the glycosides to the ghosts is, however, consistent with competitive kinetics but suggests that during the preparation of the ghosts, some loosely bound protein, essential perhaps for the tight binding of the glycosides, may have been lost.

Those few compounds tested here as ATP-ase inhibitors which had the structural feature of a carbonyl oxygen in conjunction with carbon-carbon double bond in common with the cardiac glycosides, did not throw any light upon the mode of action of the glycosides. Although some of the compounds did inhibit the enzyme system, they were not specific inhibitors of the Na-K activated ATP-ase as are the glycosides.

The results obtained from the effect of Mg:ATP ratio upon ATP-ase activity are probably not accurate enough to resolve definitively the conflict as to whether the 'true substrate' or the system is an equi-molar complex of Mg and ATP, suggested by Wheeler (45) and by Glynn (29), or a 2:1 complex (Mg_2ATP) suggested by Skou (44). The results obtained have suggested, however, that optimal activity is probably obtained at a Mg-ATP ratio not significantly different from 1. Schoner (109) has suggested that the optimal

Mg-ATP ratio depends upon the ATP concentration, although his ratios may not differ significantly from 1. Analysis of the interaction of Mg and ATP with the enzyme system by means of the Hill equation did not indicate more than one binding site for these compounds under the usual conditions of assay.

Mg-ATP may well be the 'true substrate' of the enzyme, the deviations from a definite 1:1 relationship may in part be caused by some formation of Mg_2ATP or $MgATP_2$ which might compete with the 'true substrate' Mg:ATP. A Mg_2ATP complex, however, seems unlikely according to Burton (110). Non-specific binding of Mg or ATP to ghost protein may also distort the curves.

With the use of reconstituted cells, it was found that Ca located inside the cell had qualitatively the same effect upon the ATP-ase activity of these cells as it had upon the ATP-ase activity of the ghost preparation, and is in agreement with the effects of Ca upon the cation pump found by Rummel (111). Only when located inside the cell was the OS-ATP-ase activity inhibited and as found by Rummel (111) Ca must be situated inside the cell to inhibit the cation pump. Although higher concentrations of Ca are required to inhibit the ATP-ase of reconstituted cells than that of the ghosts, this may be the result of a larger amount of non-specific binding of Ca by the former preparation. Furthermore, the OI-ATP-ase activity of reconstituted cells is inhibited only when Ca is inside the cells, suggesting that both components of the ATP-ase are located at the inner face of the membrane and not spatially localized with the OI-component situated at the

outer face and the OS-component at the inner face as previously suggested (20).

Although ATP is hydrolysed more rapidly by the OI-ATP-ase than by the OS-ATP-ase of reconstituted cells, when it is present in the medium, and by the OS-ATP-ase when it is situated inside the cells, the total ATP-ase activity of the cells is highest with internal ATP. This may result from the reconstituted cells being slightly permeable to ATP, when diffusion of ATP from the medium into the cells would result in a high Mg:ATP ratio within the cell since the cells already contain about 2 mM Mg. The K_m of ATP for the OI-ATP-ase is lower than that of the OS-component (Table XVI), and as can be seen in Fig. 20B, at low concentrations of ATP, the OI-component is much more active than the OS-ATP-ase. Thus a slow leakage of ATP into cells into which Mg, but not ATP, has been incorporated, would result in a lower total amount of ATP-ase activity, with a higher OI:OS ratio than would be obtained from cells containing a higher internal ATP concentration.

The effects of EDTA upon the ATP-ase activity of reconstituted cells may be explained on a similar basis. Although EDTA normally behaves as a non-penetrating anion, a slight leakage of EDTA into the cell would chelate some of the Mg reducing the amount of Mg available for complex formation with ATP. Such a lowering of the Mg:ATP ratio would tend to produce a greater reduction in OI-activity than in OS-activity.

It seems probable from the work of Glynn (17) and of Epstein (18) that the inhibition of ATP-ase by Ca ions is due to the binding of Ca:ATP instead of the normal substrate Mg:ATP to the active site of the enzyme. The enzyme is unable to hydrolyse Ca-ATP. No reduction in the amount of inhibition by Ca ions through raising the concentration of Mg inside the cells was observed in these experiments. This may also be due to non-specific binding of the extra Mg ions. It is not yet known whether Ca inhibits the OI-component in the same manner as the OS-fraction, nor has the initial stimulation of this component by Ca ions been explained. It is of interest to note that small amounts of calcium may regulate normal ATP-ase activity. This is suggested by the observation that hydroxylamine will not inhibit ATP-ase activity unless μ molar amounts of Ca are present (53). Hydroxylamine probably inhibits the enzyme by formation of a hydroxamate with the acyl intermediate.

The physiological consequences of a high cell Ca would be a reduction or inhibition of the active transport of Na and K ions across the cell membrane, predisposing the cell to haemolysis. Under normal circumstances, the cell calcium is low (21-56 μ mole/litre RBC) (112), too low to interfere with the active transport of Na and K ions. Thus the cell membrane acts as a permeability barrier preventing the undesirable consequences of a high cell Ca.

Whilst Ca situated inside the cell membrane would tend to lead to an inhibition of the cation pump, predisposing the

cell to haemolysis, small quantities of Ca in the medium can increase the resistance of the cell to osmotic haemolysis. Suppression of the initial haemolysis of red cells by Ca in the osmotic fragility test was first observed by Brinkman (113) and later continued by Winkler (114) and by van Kampen (115). Several other observations have indicated a close connection between Ca and the permeability of the membrane to alkali metal cations. Maizels (116) and Lyman (117) have shown that the red cells of the tortoise and turtle haemolyse in isotonic NaCl solution unless small amounts of calcium are present. Haemolysis can be prevented only by Ca and not by the other alkali metal earths. Suspension of erythrocytes in a non-electrolyte solution such as lactose renders them abnormally permeable to univalent cations. If the non-electrolyte solution contains either Ca or Mg, normal permeability is maintained (118); however, if the cells are exposed to the solution in the absence of these ions, only the subsequent addition of Ca but not Mg will restore normal permeability (119). It has been suggested that calcium is lost from cells exposed to lactose solution and can be replaced by added calcium. However, added calcium does not appear to inhibit osmotic lysis by replacing lost calcium since no difference in the susceptibility to lysis either in the presence or absence of calcium was observed between washed and unwashed cells. Also, no difference in response to added calcium was seen between cells collected into EDTA or into heparin. Calcium but not Mg also has the ability to delay the swelling of liver slices (120).

In contrast, Hoffman (20) has stressed the importance of Mg ions as a cohesive force in maintaining the permeability of the membrane. Red cell ghosts reconstituted in the absence of Mg did not retain K ions as well as cells reconstituted in the presence of these ions. Ca could not replace Mg unless ATP or a chelating agent was also present. Ponder (121) observed that exposure of red cells to isotonic CaCl_2 for 24 hours at 40°C produced a rapid loss of K from the cells with a small net loss of cation and a concomitant shrinkage of the cells. However, cells exposed to CaCl_2 in this way now had an increased osmotic fragility in hypotonic NaCl solution. Sachs (63) observed a K loss in depleted cells but not repleted cells when they were exposed to high concentrations of Ca.

Ca does not appear to inhibit the osmotic lysis of red cells by causing the cells to shrink through a selective K loss. Although the presence of Ca does not affect the mean cell volume of the cells at any particular tonicity, the cells readily lose K but not haemoglobin in the presence of Ca. Thus the Ca effect appears to be some direct action upon the membrane which does not alter cation permeability or critical haemolytic volume, but does require a lower osmolality for the same degree of haemolysis. It has been suggested that Ca may act as a membrane cement, forming a bridge between adjacent negative charges of protein and phospholipid (122). It may be that added Ca makes the cell more resistant to osmotic haemolysis by forming extra links of this type in the membrane

as the framework of the cell is stretched on exposure to hypotonic solutions, allowing K but not haemoglobin to escape. Valinomycin appears to act quite differently from Ca, producing the marked K loss and shrinkage of the cells (86) responsible for their enhanced resistance to osmotic lysis.

The investigation of some aspects of p-nitrophenyl phosphatase activity of the red cell membrane has revealed some remarkable similarities between the properties of this enzyme and the membrane ATP-ase which are consistent with the phosphatase acting as a part of the cation pump. There are, however, a few differences which would have to be explained before such a function for this enzyme could be definitely accepted.

Both enzymes reside in the membrane and are lost or retained to the same degree when the membranes are extensively washed. The cation requirements of the two enzymes are quite similar; both require Mg ions and both are activated by K ions. The simultaneous requirement for Na in the case of ATP-ase is readily explainable if it is required for the initial kinase reaction. Half maximal activation of both enzymes is obtained with similar concentrations of K. An inhibition of the phosphatase by Na would not be unexpected since an interaction between Na and K with respect to ATP-ase activity and to the cation pump have been reported previously (62,108).

Perhaps the most remarkable feature which the phosphatase activity has in common with the ATP-ase and the cation pump is the effect of ouabain upon this enzyme. The cardiac

glycosides are specific inhibitors of the Na plus K activated ATP-ase, probably the K-dependent dephosphorylation step, and also of the active movement of Na and K across the cell membrane. Thus far, no other system has been reported to be inhibited by these compounds. Inhibition therefore by ouabain of K-activated phosphatase activity strongly suggests a close similarity between the two enzymes. There is, however, a discrepancy between the amount of ouabain required to produce half-maximal inhibition of the two enzymes which is difficult to explain. Such differences were also seen in the case of the brain microsomal (123) and liver enzymes (68). It is possible that such differences in the susceptibility to ouabain might reflect slightly different conformational states in the enzyme protein, depending upon the nature of the substrate. A small change in enzyme conformation might easily change the binding constant of a large molecule like ouabain but probably not a small molecule the size of potassium.

Ca, another potent inhibitor of ATP-ase activity and the cation pump also readily inhibits the phosphatase. The K-dependent phosphatase activity and the OS-ATP-ase activity were very similar in their susceptibility to Ca. An inhibition of a Mg-dependent phosphatase by Ca would not of course be unexpected.

The phosphatase is readily inhibited by NaF as is the ATP-ase, but the degree of inhibition does not seem to depend upon the amount of free Mg, as in the case of ATP-ase. Since the original observation of an inhibition of red cell ATP-ase

by NaF (13), the effect of this inhibitor upon ATP-ase activity has, until recently (124,125), received little attention, even though under certain conditions it is a powerful ATP-ase inhibitor. The effects of NaF will therefore be discussed in a little more detail. The results presented here seem to indicate that the amount of inhibition is dependent upon the free Mg concentration. This may perhaps be the reason why little inhibition by NaF has been observed previously; e.g. Aldridge (126) found that 10 mM NaF caused no inhibition of the OI-component of brain microsomal ATP-ase and only 40% inhibition of the OS-component. However, little or no free Mg was available in his reaction mixture which contained a Mg:ATP ratio of 0.4. Opit (124) has reported that the inhibition of kidney microsomal ATP-ase is also Mg-dependent, although this enzyme is much less susceptible to inhibition by NaF than is red cell ATP-ase. The effect of NaF upon other enzymes, notably enolase (88,89), is well documented. The susceptibility of enolase to fluoride inhibition is also very dependent upon the Mg concentration but in addition, phosphate must also be present. The inhibitor in this case is a MgF_2PO_4 complex. Inhibition of ATP-ase activity does not seem to require the presence of phosphate, although this cannot be stated with certainty since the continuing hydrolysis of ATP may provide sufficient free phosphate. Like red cell ATP-ase, the inhibition of liver pyrophosphatase (127) by NaF is also Mg-dependent. It should be noted that pyrophosphate cannot replace phosphate in the MgF_2PO_4 complex inhibiting enolase.

Presumably ATP-ase inhibition is also caused by the formation of a Mg-F complex which may, as in the case of enolase (128), form a dissociable complex with the enzyme protein replacing Mg.

The inhibition of the red cell phosphatase activity seems to differ from that of the ATP-ase inasmuch as the inhibition is not Mg-dependent. There may be, however, sufficient free Mg available in this case since PNPP probably does not bind Mg as firmly as ATP. The inhibition of prostatic acid phosphatase by NaF was suggested by Reiner (129) to be due to the formation of the hydrogen-bonded polymer HF_2^- which acted as an inhibitor. This does not seem to be the case here since a plot of inhibitor concentration (taken as the concentration of NaF) against $\frac{i}{(I - i)}$ where $i = \frac{V_0 - V_i}{V_0}$, V_0 = velocity in the absence of inhibitor, V_i = velocity in the presence of inhibitor, is a straight line (129). Yoshida (125) has recently reported that the Na-K-dependent ATP-ase and K-dependent phosphatase from brain were both inhibited by NaF in a qualitatively similar, but quantitatively different manner.

Fluoride also has complex effects upon the permeability of the cell membrane to Na and K ions. At low concentrations (1 - 10 mM) it gradually slows the uptake of K by the cell (91,92). This loss of K has been ascribed to a reduction in active transport caused by an interference of the energy supply of the pump through a blockage of glycolysis by fluoride (91,92). Kirschner (130), however, found that the

inhibition of Na extrusion from swine erythrocytes by NaF occurred without affecting the cell ATP level or lactic acid production, and that at concentrations which blocked active transport, fluoride also decreased the ATP-ase activity of the membrane. It is possible that fluoride may block active transport by either inhibiting glycolysis or by inhibiting the transport ATP-ase, or by both these means, depending upon the conditions within the cell.

Although the thermal inactivation patterns of the phosphatase and ATP-ase are similar in shape, they are different in magnitude. Since the ATP-ase may be a system of enzymes, a closer similarity might not be expected.

The most obvious difference between the two activities is their pH optima. All components of the phosphatase have a pH optimum of 6.0, whereas optimum ATP-ase activity is obtained between pH 7.5 and 8.0. It is possible that the two reactions proposed as the ATP-ase cycle, the kinase and phosphatase reactions, have different pH optima, and that the experimentally determined pH optimum represents a balance between the two. In brain tissue, however, both the phosphatase and ATP-ase are maximally active at the same pH, pH 7.7 (123,131).

The non-competitive inhibition of the phosphatase in the presence of ATP might suggest that the phosphatase and ATP-ase cannot be identical enzymes but that there are two active sites which may or may not be on the same enzyme molecule. This would be the case assuming that the phosphorylated intermediate of the ATP-ase was competing with the PNPP, but

in fact the ATP itself might be blocking the active site of the phosphatase. This is suggested by the non-competitive plots obtained in the presence of ouabain, when the ATP-ase reaction is blocked, and also in the absence of Na, conditions under which no phosphorylated intermediate should be formed. At high concentrations of PNPP (>10 mM) in the absence of Na, ATP caused a stimulation of the phosphatase. Similarly non-competitive inhibition of the ATP-ase by PNPP may reflect blocking at the ATP-binding site by PNPP rather than on interaction with a phosphorylated intermediate. Fujita (123) also found non-competitive inhibition of the phosphatase by ATP, but in the absence of Na when no phosphorylated intermediate would be formed. Sachs (131), however, obtained competitive inhibition under these circumstances. It is not possible to distinguish between these two cases.

Recently, membranes from kidney (132) and brain tissue (131,133) have been shown to hydrolyse acetyl phosphate, a more likely candidate as substrate of the phosphatase in the light of recent evidence. Like the p-nitrophenyl phosphatase, it is also activated by K ions and inhibited by ouabain. Acetyl phosphate may be an alternative substrate to PNPP for the membrane phosphatase. Although it is not possible to state categorically whether or not the p-nitrophenyl phosphatase activity is indeed part of the ATP-ase system, and thus intimately connected with the cation pump, it is remarkable that there are such similarities between the two systems

with such widely different substrates as PNPP and ATP.

Treatment of erythrocyte ghosts with the non-ionic detergent Triton X-100 yielded a soluble preparation of ghost protein which contained cation-independent ATP-ase activity and p-nitrophenyl phosphatase activity. Although extraction of the ghost protein with cold n-butanol was found to produce complete loss of ATP-ase activity in this investigation, Weed (93) was able to obtain a soluble preparation of ghost protein with this solvent which retained cation-independent ATP-ase activity and also p-nitrophenyl phosphatase activity.

Butanol and detergents did, however, have a common effect upon the properties of the ghost ATP-ase; an activation of the OI-component at low concentrations followed by a loss of activity at higher concentrations. Stimulation of ATP-ase activity by certain detergents has been reported previously. Chan (134) observed an activation of red cell ATP-ase by sodium dodecyl sulphate accompanied by a change in the sensitivity of the enzyme to Na and K. Somogyi (135) found that TX-100 activated brain ATP-ase and increased the number of PCMB titratable -SH groups. However, the concentration of TX-100 which activated the enzyme did not correspond with the concentration necessary to unmask the extra -SH groups. Swanson (136,137) has extensively explored the effects of polyoxyethylene ethers upon brain ATP-ase activity.

Except for DMSO, the organic reagents ethylene glycol, dioxane, and urea which alter protein conformation, were to some extent capable of activating the OI-ATP-ase activity of the ghosts. The activation obtained here was much less than had been obtained with myosin ATP-ase (138), although the order of effectiveness was the same: i.e. ethylene glycol > dioxane > urea, and the activating concentration was of the same magnitude.

Since these reagents differ widely in their chemical constitution, it is unlikely that the activation common to them all is due to an interaction with a specific group on the enzyme. The activation is unlikely to be due to changes in the dielectric constant of the medium since urea increases the constant whilst glycol or dioxane decreases it. It may be, as has been suggested (138), that reagents like ethylene glycol, dioxane, and urea activate the ATP-ase by bringing about a partial unfolding of the enzyme molecule in the region of the active site, though changes in structure at the activating concentrations of these reagents have only been obtained in the case of ethylene glycol. Although DMSO does not activate red cell ghost ATP-ase, certain enzymes such as ribonuclease (139) and E. coli phosphomonoesterase (140) are activated by this solvent whilst others such as trypsin (140) are inhibited. As with the red cell ATP-ase, the OS-component of gastric mucosal ATP-ase was found to be more sensitive to DMSO than the OI-component (141). Reversible configurational changes in protein structure in the presence of DMSO have also

been reported (142). Because of its small size, DMSO, which strongly H-bonds with water, may be able to penetrate regions of the protein inaccessible to bulkier molecules and substitute for bound water. The loss of ATP-ase activity may be the result of such a penetration.

As with the organic reagents affecting protein conformation, the initial activation of the OI-activity by the detergents and butanol may be due to some unfolding at the active site of the enzyme. The inhibition produced by them is probably due to the breakdown of essential lipoprotein bonds. Thus the initial activation of the OI-component followed by inhibition or inactivation after prolonged exposure to SLS, may be due to unfolding followed by disruption of essential lipid-protein complexes. Since about 30% of the membrane protein was lost to the supernatant after 20 hours exposure to SLS, it is possible that the OI-component has been removed from the membrane, though it is not yet known whether the two components of the ATP-ase are in fact separate enzymes. It is of interest to note that it has recently been shown (143) that certain organic solvents such as acetone, which are known to break lipoprotein bonds, inactivate the red cell ATP-ase at precisely those concentrations which cause haemolysis of the cell.

An intact lipoprotein network in the membrane certainly seems necessary for complete ATP-ase activity, which is perhaps the reason for the loss of cation sensitivity observed here with the TX-100 solubilised preparation. This might not

be unexpected since an ATP-ase system functioning as a cation pump would also require vectorial properties. These would probably be imparted by its three-dimensional structure in the lipoprotein network of the cell membrane. Disruption of the lipoprotein network would thus destroy the vectorial nature of the system, resulting in a loss of cation-sensitivity of the enzyme.

BIBLIOGRAPHY

1. J.E. Harris (1941). J. Biol. Chem. 141, 579.
2. M. Maizels (1951). J. Physiol. 112, 59.
3. T.I. Shaw (1955). J. Physiol. 129, 464.
4. I.M. Glynn (1956). J. Physiol. 134, 278.
5. R.C. Post and P.C. Jolly (1957). Biochim. Biophys. Acta 25, 118.
6. H.J. Schatzmann (1953). Helv. Physiol. Acta 11, 346.
7. I.M. Glynn (1957). J. Physiol. 136, 148.
8. R. Whittam (1958). J. Physiol. 140, 479.
9. G. Gàrdos (1954). Acta Physiol. Sci. Hung. 6, 191.
10. G. Gàrdos and F.B. Straub (1956). Acta Physiol. Sci. Hung. 12, 1.
11. J.F. Hoffman (1960). Fed. Proc. 19, 127.
12. E.M. Clarkson and M. Maizels (1952). J. Physiol. 116, 112.
13. E. Herbert (1956). J. Cell. Comp. Physiol. 47, 28.
14. T. Garzó, A. Ullman and F.B. Straub (1952). Acta Physiol. Acad. Sci. Hung. 3, 513.
15. J.C. Skou (1957). Biochim. Biophys. Acta 23, 394.
16. R.L. Post, C.R. Merritt, C.R. Kinsolving, C.D. Albright (1960). J. Biol. Chem. 235, 1796.
17. E.T. Dunham and I.M. Glynn (1961). J. Physiol. 156, 274.
18. F.H. Epstein and R. Whittam (1966). Biochem. J. 99, 232.
19. J.C. Skou (1965). Physiol. Rev. 45, 596.
20. J.F. Hoffman (1962). Circulation 26, 1201.
21. D.C. Tosteson, M.P. Blaustein, and R.H. Moulton (1961). Fed. Proc. 20, 138.

22. J.D. Judah, K. Ahmed, A.E.M. McLean (1962). *Biochim. Biophys. Acta* 65, 472.
23. R.I. Weed and G.G. Berg (1962). *Fed. Proc.* 22, 213.
24. D.C. Tosteson (1963). *Fed. Proc.* 22, 19.
25. H. Yoshida and H. Fugisawa (1962). *Biochim. Biophys. Acta* 60, 443.
26. T. Nakao, K. Nagano, K. Adachi, M. Nakao (1963). *Biochem. Biophys. Res. Comm.* 13, 444.
27. D.C. Tosteson, P. Cook and R. Blount (1965). *J. Gen. Physiol.* 48, 1125.
28. R. Whittam (1962). *Biochem. J.* 84, 110.
29. I.M. Glynn (1962). *J. Physiol.* 160, 18P.
30. P.C. Caldwell and R.D. Keynes (1959). *J. Physiol.* 148, 8P.
31. E. J. Harris (1954). *Symp. Soc. Expt. Biol.* 8, 228.
32. R.L. Post and P.C. Jolly (1957). *Biochim. Biophys. Acta* 25, 118.
33. D.C. Tosteson (1955). in "Electrolytes in Biological Systems." ed. A.M. Shanes (American Physiological Society) Washington, D.C.
34. P.D. McConaghey and M. Maizels (1962). *J. Physiol.* 162, 485.
35. P.J. Garrahan and I.M. Glynn (1967). *J. Physiol.* 192, 217.
36. G. Gardos (1964). *Experient.* 20, 387.
37. A.K. Sen and R.L. Post (1964). *J. Biol. Chem.* 239, 345.
38. R. Whittam in "Transport and Diffusion in Red Blood Cells", E. Arnold, London, Publishers, p. 151, 1964.

39. R. Whittam (1961). *Nature* 191, 603.
40. A. Elshove and G.D.V. van Rossum (1963). *J. Physiol.* 168, 531.
41. R. Whittam and M.E. Ager (1965). *Biochem. J.* 97, 214.
42. J.C. Parker and J.F. Hoffman (1967). *J. Gen. Physiol.* 50, 893.
43. L.E. Hokin and M.R. Hokin (1963). *Fed. Proc.* 22, 8.
44. J.C. Skou (1960). *Biochim. Biophys. Acta* 42, 6.
45. K.P. Wheeler and R. Whittam (1962). *Biochem. J.* 85, 495.
46. L.J. Opit and J.S. Charnock (1965). *Nature* 208, 471.
47. E. Heinz and J.F. Hoffman (1965). *J. Cell. Comp. Physiol.* 65, 31.
48. R.L. Post, A.K. Sen, and A.S. Rosenthal (1965). *J. Biol. Chem.* 280, 1437.
49. A. Kahlenberg, P.R. Galsworthy and L.E. Hokin (1967). *Science* 157, 43.
50. H. Bader, A.K. Sen and R.L. Post (1966). *Biochim. Biophys. Acta* 118, 116.
51. W. Schoner, R. Kramer and W. Seubert (1966). *Biochem. Biophys. Res. Comm.* 23, 403.
52. C.F. Chignell and E. Titus (1966). *Proc. Natl. Acad. Sci. U.S.* 56, 1620.
53. H. Bader and A.H. Broom (1967). *Biochim. Biophys. Acta* 79, 581.
54. J.S. Charnock and R.L. Post (1963). *Nature* 199, 910.
55. J.S. Charnock, A.S. Rosenthal and R.L. Post (1963). *Aust. J. Exptl. Biol. Med. Sci.* 41, 675.

56. L.E. Hokin and M.R. Hokin (1961). *Nature* 189, 836.
57. L.E. Hokin and M.R. Hokin (1963). *Fed. Proc.* 22, 8.
58. O. Jardetzky (1966). *Nature* 211, 969.
59. R.F. Squires (1965). *Biochem. Biophys. Res. Comm.* 14, 118.
60. K. Ahmed and J.D. Judah (1966). *Biochim. Biophys. Acta* 120, 351.
61. J.F. Hoffman (1962). *Fed. Proc.* 21, 145.
62. J.R. Sachs and L.G. Welt (1967). *J. Clin. Invest.* 46, 65.
63. J.R. Sachs (1967). *J. Clin. Invest.* 46, 1434.
64. P.J. Garrahan and I.M. Glynn (1967). *J. Physiol.* 192, 175.
65. J.F. Hoffman (1966). *Amer. J. Med.* 41, 666.
66. H. Matsui and A. Schwartz (1966). *Biochem. Biophys. Res. Comm.* 25, 147.
67. H.J. Schatzmann (1965). *Biochim. Biophys. Acta* 94, 89.
68. P. Emmelot and C.J. Bos (1965). *Biochem. J.* 99, 578.
69. K. Nagai, F. Izumi and H. Yoshida (1966). *J. Biochem.* 59, 991.
70. R.N. Albers, G.R. De Lores Arnaiz and E. de Robertis (1965). *Proc. Nat. Acad. Sci. U.S.* 53, 557.
71. R.I. Weed (1962). Personal communication to Dr. H. B. Collier.
72. R.I. Weed, C.F. Weed and G. Berg (1963). *J. Clin. Invest.* 42, 581.
73. J.G. Reinhold in "Standard Methods in Clinical Chemistry", ed. M. Reiner, Vol. 1, Academic Press, N.Y., p. 88. (1953).

74. E.J. van Kampen & W.G. Zijlstra. "Erythrocytometric Methods and their Standardization". Transactions of the Standardization Committee and Proceedings of Symposium XVIII of the Ninth Congress of the European Society of Haematology. Lisbon, 1963, p. 68.
75. E. Beutler and M.C. Baluda (1964). *Blood* 23, 688.
76. F.H. Epstein and R. Whittam (1966). *Biochem. J.* 99, 232.
77. C.H. Fiske and Y. Subbarow (1925). *J. Biol. Chem.* 66, 375.
78. H. Lineweaver and D. Burk (1934). *J. Amer. Chem. Soc.* 56, 658.
79. J. Monod, J.P. Changeux and F.J. Jacob (1963). *J. Mol. Biol.* 6, 306.
80. E. Vinuela, M.L. Salas and A. Sols (1963). *Biochem. Biophys. Res. Comm.* 13, 140.
81. D.E. Atkinson, J.A. Hathaway and E.C. Smith (1965). *J. Biol. Chem.* 240, 2682.
82. A. Hunter and C.E. Downs (1945). *J. Biol. Chem.* 157, 427.
83. S. Kashket and O.F. Denstedt (1958). *Can. J. Biochem. Physiol.* 36, 1057.
84. S.L. Schrier, L.D. Doak and B. Carr (1966). *Amer. J. Physiol.* 210, 139.
85. D.E. Green, E. Murer, H.O. Hultin, S.H. Richardson, B. Salmon, G.P. Brierley and H. Baum (1965). *Arch. Biochem. Biophys.* 112, 635.
86. D.C. Tosteson, P. Cook, T. Andreoli and M. Tieffenberg (1967). *J. Gen. Physiol.* 50, 2513.

87. H.B. Collier. Unpublished observations.
88. O. Warburg and W. Christian (1941). *Biochem. Z.* 310, 384.
89. R.A. Peters (1964). *Nature* 202, 1331.
90. H. Davson (1941). *J. Cell. Comp. Physiol.* 18, 173.
91. R.E. Eckel (1958). *J. Cell. Comp. Physiol.* 51, 81.
92. S. Lepke and H. Passow (1967). *J. Physiol.* 191, 39P.
93. A.F. Rega, R.I. Weed, C.F. Reed, G.G. Borg and A. Rothstein (1967). *Biochim. Biophys. Acta* 147, 297.
94. I.M. Glynn (1964). *Pharmacol. Rev.* 16, 381.
95. H.J. Portius and K. Repke (1964). *Arzneimittel-Forsch.* 14, 1073.
96. H.D. Brown (1966). *Biochem. Pharmacol.* 15, 2007.
97. H.D. Brown, R.T. Jackson and M.B. Waitzman (1967). *Life Sciences* 6, 1519.
98. D.E. Duggan, and R.M. Noll (1965). *Arch. Biochem. Biophys.* 109, 388.
99. P.W. Davis and T.M. Brody (1966). *Biochem. Pharmacol.* 15, 703.
100. J.D. Judah and K. Ahmed (1964). *J. Cell. Comp. Physiol.* 64, 355.
101. J. Bremer (1962). *J. Biol. Chem.* 237, 2228.
102. H.P. Kleber and H. Aurich (1967). *Biochem. Biophys. Res. Comm.* 26, 255.
103. G.L. Ellman (1959). *Arch. Biochem. Biophys.* 82, 70.
104. S. Friedman and G. Fraenkel (1955). *Arch. Biochem. Biophys.* 59, 491.

105. J. Bremer (1962). J. Biol. Chem. 237, 3628.
106. R. Dargel and E. Strack (1966). Ac. Biol. Med. Germ. 17, 704.
107. J.C. Skou (1962). Biochim. Biophys. Acta 58, 314.
108. A.L. Green and C.B. Taylor (1964). Biochem. Biophys. Res. Comm. 14, 118.
109. W. Schoner, C. von Ilberg, R. Kramer, and W. Seubert (1967). Eur. J. Biochem. 1, 334.
110. K. Burton (1959). Biochem. J. 71, 388.
111. H. Rummel, E. Seifen and J. Baldauf (1963). Biochem. Pharmacol. 12, 557.
112. L.S. Valberg, R.T. Card, E.J. Paulson and J. Szivek (1965). Comp. Biochem. Physiol. 15, 347.
113. R. Brinkman (1919). Biochem. Z. 95, 101.
114. K.C. Winkler (1938). Thesis, Leiden.
115. E.J. van Kampen, J.J.F. Hasselman and C.A. Graafland (1958). Clin. Chim. Acta 3, 578.
116. M. Maizels (1956). J. Physiol. 132, 414.
117. R.A. Lyman (1945). J. Cell. Comp. Physiol. 25, 65.
118. W. Wilbrandt (1940). Pflüg. Arch. ges. Physiol. 243, 537.
119. V. Bolingbroke and M. Maizels (1959). J. Physiol. 149, 563.
120. H. Aebi (1950). Helv. Physiol. Acta 8, 525.
121. E. Ponder (1953). J. Gen. Physiol. 36, 767.
122. R. Whittam in "Transport and Diffusion in Red Blood Cells" (1964): Monograph of the Physiol. Soc. No. 13. E. Arnold, Publisher, p. 34.

123. M. Fujita, T. Nakao, Y. Yoshima, N. Mizuno, K. Nagano and M. Nakao (1966). *Biochim. Biophys. Acta* 117, 42.
124. L.J. Opit, H. Potter and J.S. Charnock (1966). *Biochim. Biophys. Acta* 120, 159.
125. H. Yoshida, K. Nagai, M. Kamei and Y. Nakagawa (1968). *Biochim. Biophys. Acta* 150, 162.
126. W.N. Aldridge (1962). *Biochem. J.* 83, 527.
127. W.H. Elliot (1957). *Biochem. J.* 65, 315.
128. O. Meyerhof in "The Enzymes", ed. J.B. Sumner and K. Myrback, Academic Press, N.Y. (1951). Vol. II, Part I, p. 1207.
129. J.M. Reiner, K.K. Tsuboi and P.B. Hudson (1955). *Arch. Biochem.* 56, 165.
130. L.B. Kirschner (1964). *Arch. Biochem. Biophys.* 106, 57.
131. G. Sachs, J.D. Rose and B.I. Hirschowitz (1967). *Arch. Biochem. Biophys.* 119, 277.
132. H. Bader and A.K. Sen (1966). *Biochim. Biophys. Acta* 118, 116.
133. Y. Israel and E. Titus (1967). *Biochim. Biophys. Acta* 139, 450.
134. P.C. Chan (1967). *Biochim. Biophys. Acta* 135, 53.
135. J. Somogyi and J.G. Gáal (1965). *Experient.* 21, 573.
136. P.D. Swanson, H.F. Bradford and H. McIlwain (1964). *Biochem. J.* 92, 235.
137. P.D. Swanson (1966). *J. Neurochem.* 13, 229.
138. C.M. Kay and J. Brahm (1963). *J. Biol. Chem.* 238, 2945.

139. C. Monder (1967). *Annals N.Y. Acad. Sci.* 141, 300.
140. D.H. Rammner (1957). *Annals N.Y. Acad. Sci.* 141, 291.
141. G. Sachs, R.H. Collier and B.I. Hirschowitz (1966).
Fed. Proc. 25, 199.
142. K. Hamaguchi (1964). *J. Biochem.* 96, 626.
143. B. Roelofsen, H. Baadenhuysen, L.L.M. van Deenen
(1966). *Nature* 221, 1379.
144. W. McD. Armstrong and A. Rothstein (1967). *J. Gen.
Physiol.* 50, 967.