

University of Alberta
Department of Civil &
Environmental Engineering



Structural Engineering Report No. 245

BEHAVIOUR OF TRANSVERSE FILLET WELDS

by
Anthony K.F. Ng
Robert G. Driver
and
Gilbert Y. Grondin

October, 2002

BEHAVIOUR OF TRANSVERSE FILLET WELDS

by

Anthony K.F. Ng

Robert G. Driver

and

Gilbert Y. Grondin

Structural Engineering Report 245

Department of Civil and Environmental Engineering

University of Alberta

Edmonton, Alberta, Canada

October 2002

ABSTRACT

The current design equations in the structural steel design standards in North America (CSA-S16 and AISC Specification) for the design of fillet welds permit an increase in fillet weld strength as the angle between the weld axis and the direction the applied load increases, based primarily on the work of Miazga and Kennedy (1989) and Lesik and Kennedy (1990). The permissible increase in predicted strength is 50% for welds loaded transversely. Such a drastic increase has recently been the subject of concern, since the design model was based on the experimental results of only one filler metal (E7014) and a welding process (shielded metal arc welding (SMAW)) not widely used by the steel fabrication industry for production work. Although E7014 electrodes have no specified toughness requirement, the level of toughness was not determined and may have been influential to the strength and ductility of fillet welds.

The objective of this research program is to expand the experimental work of Miazga and Kennedy on transverse fillet welds and to investigate the influences of a wide variety of parameters on transverse fillet weld behaviour. The research is intended to confirm the applicability of the current design model to a broader range of filler metal types, namely, flux core arc welding (FCAW) filler metals with and without a specified toughness. A total of 102 transverse fillet weld specimens were tested to assess the influences of the following parameters: filler metal classifications with and without a specified toughness; SMAW vs. FCAW filler metals; fillet weld size and number of passes; electrode manufacturer; steel fabricator (welder); weldment geometry (lapped splice vs. cruciform); and low temperature.

ACKNOWLEDGEMENTS

This research project is founded by American Institute of Steel Construction and the Natural Science and Engineering Research Council of Canada.

The work presented in this report was conducted with the assistance of Miss Kam Deng, Mr. Logan Callele, and Mr. Cameron Franchuk, MSc students, and Mr. Mohammad Behbahanifard, PhD student in the Department of Civil and Environmental Engineering, University of Alberta.

TABLE OF CONTENTS

ABSTRACT.....	i
TABLE OF CONTENTS.....	iv
LIST OF TABLES.....	vii
LIST OF FIGURES	viii
LIST OF SYMBOLS.....	ix
1. INTRODUCTION	1
1.1 General.....	1
1.2 Background.....	1
1.3 Objectives	2
1.4 Scope.....	3
2. LITERATURE REVIEW	5
2.1 General.....	5
2.2 Experimental and Theoretical Studies on Fillet Welds.....	6
2.2.1 Ligtenburg.....	6
2.2.2 Higgins and Preece	6
2.2.3 Clark.....	7
2.2.4 Butler and Kulak.....	7
2.2.5 Butler, Pal and Kulak	8
2.2.6 Biggs, Crofts, Higgs, Martin, and Tzogius.....	9
2.2.7 Swannell.....	10
2.2.8 Kamtekar.....	10
2.2.9 Pham	12
2.2.10 Kennedy and Kriviak	12
2.2.11 Mansell and Yadav	13
2.2.12 Miazga and Kennedy	13
2.2.13 Lesik and Kennedy	14
2.2.14 Bowman and Quinn	15
2.2.15 Iwankiw.....	16
2.3 Summary	17
3. EXPERIMENTAL PROGRAM	19
3.1 Test Specimens	19
3.1.1 General.....	19
3.1.2 Filler Metals.....	20
3.1.3 Base Plates	20
3.1.4 Fillet Weld Specimens	21
3.1.5 Ancillary Test Specimens	21
3.1.6 Specimen Fabrication.....	22

3.2	Transverse Fillet Weld Experimental Program.....	23
3.2.1	Preparation of Specimens	23
3.2.2	Test Setup.....	23
3.2.3	Test Procedure	24
3.2.4	Tests at -50°C.....	24
3.3	Summary	25
4.	TEST RESULTS.....	37
4.1	All-Weld-Metal Tension Coupon Tests.....	37
4.2	Base Plate Tension Coupon Tests.....	37
4.3	Charpy V-notch Impact Tests	38
4.4	Weld Metal Chemical Analysis	38
4.5	Hardness Measurements	38
4.6	Transverse Fillet Weld Tests	39
5.	ANALYSIS AND DISSCUSSION	47
5.1	Comparison with Miazga and Kennedy (1989).....	47
5.2	Effect of Variables on Fillet Weld Behaviour	50
5.2.1	General.....	50
5.2.2	Filler Metal Classification and Toughness	51
5.2.3	Electrode Manufacturer	52
5.2.4	Steel Fabricator	53
5.2.5	Weld Size.....	54
5.2.6	Root Notch Orientation.....	54
5.2.7	Low Temperature.....	55
5.2.8	Unequal Leg Dimension	56
5.2.9	Summary of Effect of Variables on Fillet Weld Behaviour	56
5.3	Fracture Surface Examination.....	57
5.4	Comparison with Current Design Equation.....	58
5.5	Evaluation of Safety Index.....	60
6.1	SUMMARY AND CONCLUSIONS	81
6.2	FUTURE WORK.....	85
	REFERENCES	87
Appendix A	Welding Procedure Specifications	A - 1
Appendix B	Etched Specimen Cross-Sections	B - 1
Appendix C	Weld Measurements and Weld Profiles	C - 1
Appendix D	Material Tension Coupon Test Results	D - 1
Appendix E	Transverse Fillet Weld Test Results.....	E - 1
Appendix F	Transverse Fillet Weld Stress Versus Strain Response.....	F - 1
Appendix G	Weld Hardness Test Results.....	G - 1
Appendix H	Examination of Fracture Surface.....	H - 1

LIST OF TABLES

<u>Table</u>	<u>Page</u>
3.1 Description of Flux-Cored Arc Welding Electrodes	27
3.2 Matrix of Test Specimens	28
3.3 Mean Fillet Weld Dimensions	29
4.1 Mean Weld Metal Tension Coupon Test Results	42
4.2 Mean Base Metal Tension Coupon Test Results	42
4.3 Charpy V-notch Impact Test Results	42
4.4 Weld Metal Chemical Analysis	43
4.5 Mean Hardness of All-Weld-Metal Coupons	43
4.6 Mean Hardness of Lapped Splice Specimens	44
4.7 Mean Transverse Fillet Weld Test Results	45
5.1 Comparison of Welding Parameters and Material Properties	65
5.2 Summary of Results of Specimens Made with E7014 Filler Metal	66
5.3 Safety Indices	67

LIST OF FIGURES

<u>Figure</u>	<u>Page</u>
2.1 Plane of Maximum Shear Stress of Unequal Leg Fillet Weld.....	18
3.1 Transverse Fillet Weld Test Specimens.....	32
3.2 Fabrication of Test Specimens.....	33
3.3 Pre-test Fillet Weld Throat Measurements	34
3.4 Test Set-up and Instrumentation	35
3.5 Lapped Splice Specimen Test at -50°	36
4.1 Non-uniform Failure Surface.....	46
5.1 Comparison of Weld Strength on for E7014 Filler Metal	68
5.2 Comparison of Weld Ductility for E7014 Filler Metal.....	68
5.3 Effect of Filler Metal Classification on Fillet Weld Behaviour.....	69
5.4 Effect of Electrode Manufacturer on Fillet Weld Behaviour.....	70
5.5 Effect of Steel Fabricator on Fillet Weld Behaviour	71
5.6 Effect of Weld Size on Fillet Weld Behaviour	72
5.7 Effect of Root Notch Orientation on Fillet Weld Behaviour.....	73
5.8 Effect of Low Temperature on Fillet Weld Behaviour.....	74
5.9 Fracture Surface of SMAW and FCAW Specimens.....	75
5.10 Typical Weld Fracture Surfaces.....	76
5.11 Fillet Weld Ductility Summary.....	77
5.12 Fracture Surface of Fillet Weld.....	78
5.13 CSA-S16 Test vs. Predicted Capacity	79
5.14 AISC Test vs. Predicted Capacity.....	80

LIST OF SYMBOLS

$A_{fracture}$	fracture surface area, mm ²
A_{throat}, A_w	theoretical throat area, mm ²
d	weld leg size, mm
D	fillet weld gauge length, mm
L	the weld length, mm
P	apply load; capacity of fillet weld, kN
R_{ult}	ultimate load per unit length, kips/in.
V_0, P_0	strength of longitudinal fillet weld, MPa
V_G	coefficient of variation of the measured-to nominal ratio of theoretical throat area
V_{M1}	coefficient of variation of the measured ultimate tensile to nominal strength of weld metal
V_{M2}	coefficient of variation of the measured shear to tensile strength of weld metal
V_P	coefficient of variation of the mean test to predicted capacity
V_θ, P_θ	strength of fillet weld oriented at an angle θ , MPa
V_r	capacity of fillet weld, kN
X_u, F_{EXX}	ultimate tensile strength of weld metal
α	angle between the shear leg and the face of the weld, degrees
α_R	coefficient of separation
β	safety index

Δ	fillet weld deformation, mm
Δ_f	fillet weld deformation at fracture, mm
Δ_u	fillet weld deformation at ultimate load, mm
ϕ	resistance factor
Φ_β	adjustment factor for ϕ
θ	angle between the apply load and the weld axis, degrees
ρ_G	mean value of the measured-to-nominal ratio of theoretical throat area
ρ_{M1}	mean ratio of the measured ultimate tensile to nominal strength of weld metal
ρ_{M2}	mean ratio of the measured shear to tensile strength of weld metal
ρ_P	professional factor (the mean test to predicted capacity ratio)
ρ_R	bias coefficient for resistance
σ_u	ultimate tensile strength of weld metal, MPa
τ_u	mean values of the ultimate shear strength from longitudinal fillet weld

1. INTRODUCTION

1.1 General

The behaviour of fillet welds has been known for decades to be a function of the direction of the applied load with respect to the weld axis. Experimental studies have shown that fillet welds loaded transversely (perpendicular to the axis of the weld) tend to have the upper bound of strength, but the lower bound for overall connection ductility, and those loaded longitudinally (parallel to the axis of the weld) tend to have the lower bound of strength, but the upper bound for overall connection ductility. This research program investigates the behaviour of transverse fillet welds made with filler metals with and without a toughness requirement specified in the governing AWS specification. It also assesses, for a variety of types of filler metal and different welding processes, the applicability of the design equations currently used in North America for predicting the capacity of transverse fillet welds.

1.2 Background

Miazga and Kennedy (1989) proposed a method to predict the strength of fillet welds based on the maximum shear stress failure criterion. This analytical result was compared with their own test results, as well as those of others (Butler and Kulak, 1971; Clark, 1971; Holtz and Hare, unpublished data). Lesik and Kennedy (1990) extended the experimental work done by Miazga and Kennedy (1989), and proposed a simplified equation, for which predicted weld strength deviates from that predicted by the Miazga and Kennedy (1989) by less than 1.5%. This equation is a function only of the direction of load and takes the form of a multiplier that is applied to the longitudinal fillet weld strength:

$$V_{\theta} / V_0 = 1.0 + 0.50 \sin^{1.5} \theta \quad [1.1]$$

where V_{θ} / V_0 is the ratio of the strength of the fillet weld (oriented at an angle θ) to that of an equal size longitudinal fillet weld, and θ is the angle between the weld axis and the direction of load. This design method forms part of the current Canadian structural steel design standard, CSA-S16 (CSA 2001), to predict the load capacity of fillet welded

connections, and has been recently adopted in Appendix J of the American Institute of Steel Construction specification (AISC 1999). This method predicts that a transverse fillet weld has 50% more capacity than an equal size longitudinal fillet weld. This drastic increase in load capacity has recently been a subject of concern since Miazga and Kennedy (1989) performed all their tests using only one type of filler metal, E7014, and a welding process, shielded metal arc welding (SMAW), not commonly used by the steel fabrication industry for production work. E7014 filler metal does not have specified toughness requirements; however, the level of its toughness was not determined and may have been influential to the strength and ductility of the fillet welds.

Besides the uncertainty of the influence of filler metal toughness to the strength of fillet welds, many parameters may also be influential to the behaviour of fillet welded connections. These parameters are steel fabricator, filler metal manufacturer, weld size and number of weld passes, stress level of the base plate and surrounding temperature. The quality control of a steel fabricator affects the performance of fillet welds directly. The performance is highly dependent on the skill of the welder and the heat input, which is related to the voltage and current settings during the welding process. The chemical composition of filler metals is another factor influencing the behaviour of fillet welds. Different electrode manufacturers may produce filler metals with different chemical compositions, each conforming to the same AWS specification, and this may result in different performance of fillet welds. Number of weld passes may be a factor affecting the behaviour of fillet welds because failure may tend to follow the interface between passes. Fillet welds that fail prior to the yielding of base plate may have a higher ultimate capacity because the amount of restraint from the base plate may be influential. Decreasing the temperature of steel results in a decrease in toughness. The change of toughness may be influential to the strength and ductility of fillet welds.

1.3 Objectives

The objectives of this study are:

1. to extend the experimental program of Miazga and Kennedy (1989) on transverse fillet welds to include flux cored arc welding (FCAW) and filler metals with a toughness requirement.

2. to confirm the applicability of the current provisions of design standards to a broader range of filler metal types.
3. to investigate the influence of each of the following parameter on the behaviour of transverse fillet welds:
 - steel fabricator
 - electrode manufacturer
 - weld size and number of passes
 - root notch orientation
 - surrounding temperature

1.4 Scope

A series of 102 transverse fillet weld specimens were tested: ninety-six double lapped splice and six in a cruciform configuration. The latter were tested to investigate the effect of the root notch orientation imposed by the weldment geometry on weld behaviour. Although specimens were prepared primarily using FCAW, nine test specimens were prepared using SMAW with E7014 filler metal, to provide a direct comparison to the results of Miazga and Kennedy. Two FCAW filler metals (E70T-4 and E70T-7) without a specified toughness requirement and two FCAW filler metals (E70T7-K2 and E71T8-K6) with a specified toughness requirement were investigated. Two weld sizes, 6.4 mm (1/4 in.) and 12.7 mm (1/2 in.), have been included in this study. The former were deposited in one pass and the latter in three passes. Welds with multiple passes were included, in part, to investigate the effect of potential tempering of the root pass by the deposition of subsequent passes. Two local steel fabricators and filler metals from two large manufacturers were used in this study to assess the associated resulting variability in fillet weld behaviour. Three specimens were tested at -50°C to determine

the effect of low temperature. In all cases, tests were conducted in triplicate to provide a means of assessing statistically the variability of the parameters investigated. The level of safety of fillet welds provided by current design methods is assessed by evaluating the safety index.

2. LITERATURE REVIEW

2.1 General

This review of the behaviour of fillet welds covers experimental and theoretical studies from the early 1960s to the present. The focus is primarily on the behaviour of transverse fillet welds (loads perpendicular to weld axis). However, longitudinal fillet welds (loads parallel to weld axis) and fillet welds loaded at intermediate angles, as well as fillet weld groups are also reviewed briefly.

The majority of transverse fillet weld tests described in the literature were conducted using lap spliced specimens that were prepared using filler metal without a specified toughness requirement. In general, the shielded metal arc welding process (SMAW) was used, although a few recent test specimens were prepared by the flux core arc welding process (FCAW). Prior to the tests conducted as part of this research, results of specimens prepared using filler metal with a toughness requirement explicitly specified in the associated electrode classification standard were not available. Moreover, no tests were discovered in the literature where the base plates yielded before weld fracture, despite the fact that the reduced restraint (to the weld) of this condition could result in lower weld capacities. A few experimental research programs have been conducted using cruciform specimens for transverse fillet welds, which provides a more severe stress condition than does the lap splice.

It is widely accepted that transverse fillet welds define the upper bound strength and lower bound ductility, and longitudinal fillet welds define the lower bound strength and upper bound ductility. This concept has been verified by several of the early studies. The most significant experimental studies on the behaviour of fillet welds were conducted by Higgins and Preece (1969), Clark (1971), Butler and Kulak (1971), Butler *et al.* (1972), Biggs *et al.* (1981), Swannell (1981), Kamtekar (1982), Pham (1983), Mansell and Yadav (1985), Miazga and Kennedy (1989), and Bowman and Quinn (1994). As well, a significant amount of theoretical research has been done, as described in the next section.

2.2 Experimental and Theoretical Studies on Fillet Welds

2.2.1 *Ligtenburg*

An international test series involving fillet weld specimens loaded in tension was reported by Ligtenburg (1968). Including Canada, ten countries participated in this study. Each country performed separate tests on longitudinal and transverse fillet welds with the weld tensile strength ranging from about 450 MPa to 580 MPa. The strength of transverse fillet welds was found statistically to be 1.59 times that of equivalent longitudinal fillet welds.

2.2.2 *Higgins and Preece*

With the objective of reevaluating the conclusions of an experimental program published by the American Welding Society in 1931 in order to account for subsequent changes in welding procedures and the increased use of higher strength materials, a series of 168 tests on longitudinal and transverse fillet welds were conducted by Higgins and Preece (1969). A variety of SMAW electrodes (E60XX, E70XX, E90XX and E110XX), base metals (ASTM A36, A441 and A514), fillet sizes (6.35 mm (1/4 in.), 9.53 mm (3/8 in.), and 12.7 mm (1/2 in.)), and weld lengths (from 38.1 mm (1-1/2 in.) to 102 mm (4 in.)) were used in this study. Two steel fabricators were used to produce test specimens. To determine the influence of dilution on the strength of the fillet weld when the mechanical properties of weld metal are different than those of the base metal, combinations of strong base metal with weaker weld metal and strong weld metal with weaker base metal were investigated. For each combination of electrode classification, base metal, and size and type of weld, a total of six tests were conducted—three by each fabricator.

It was reported that 6.35 mm fillet welds made with E110XX filler metals on steel having tensile strength 36% less than that required for these electrodes were only 8% weaker than those deposited by the same filler metals on A514 steel. Conversely, same size fillet welds made with E70XX filler metals on A514 steel having a tensile strength 65% greater than that required of the filler metals were only 2% stronger than those deposited on steel having approximately the same mechanical properties as the filler metals. For welds made by E70XX electrodes and deposited on matching base metals

(A441), the average factor of safety for transverse fillet welds was 1.57 times that of longitudinal fillet welds. (The allowable stress was 0.3 times the specified tensile strength of the electrode.) The fracture planes of longitudinal welds generally were less than 45° to the plane of the specimen and of transverse welds were about 0° , although the value was not reported explicitly. The fracture surfaces of the transverse fillet welds were relatively smooth, whereas those of the longitudinal welds consisted of a series of helical-shape tears.

2.2.3 Clark

Results of 18 fillet weld specimens, all with a nominal leg size of 8 mm, were reported by Clark (1971). This series of specimens included 0° , 30° , 60° and 90° fillet weld orientations. The filler metal classification and base metal grade were not reported. The load-deformation curves of these fillet welds were generally similar to those obtained by Butler and Kulak (1971). The results showed an increase in strength of approximately 70% as the angle between the direction of load and the weld axis changed from 0° to 90° . The longitudinal welds also exhibited significantly more deformation at rupture than did the transverse welds.

Clark (1971) also presents a review of several strength models and design code provisions for fillet welds. It was reported that all theoretical stress models, including principle stress theory, maximum shear stress theory, and strain energy criteria, with the yield stress replaced by the ultimate stress in the equations, underestimated the true strength of fillet welds. The author argued that the restraint resulting from the base plate is an important factor in explaining the discrepancy between theoretical and tested strengths. Considerable discrepancies among the design codes reviewed were reported.

2.2.4 Butler and Kulak

A series of 23 6.35 mm (1/4 in.) fillet weld specimens were tested by Butler and Kulak (1971) to establish the load-deformation response of fillet welds loaded in different directions, namely 0° (longitudinal), 30° , 60° , and 90° (transverse) to the weld axis. The specimens were prepared using E60XX electrodes and G40.12 steel plate, with a

specified yield stress of 300 MPa (44 ksi) and a minimum tensile strength of 430 MPa (62 ksi).

The test results showed that the increase in strength of the fillet welds was approximately 44% as the angle of load changed from 0° to 90°. It was also reported based on measured deformations across the welds that the ductility of specimens loaded longitudinally was nearly four times that of those loaded transversely, although if the reported deformations are converted to strains, there is little variation in ductility with weld orientation. An empirical equation was obtained to predict the load capacity as a function of the direction of the applied load to the weld axis:

$$R_{ult} = \frac{10 + \theta}{0.92 + 0.0603\theta} \quad [2.1]$$

where R_{ult} is the ultimate load per unit length (kips/in.), and θ is the angle between the direction of load and the weld axis (degrees). Another empirical equation was proposed that predicts the full load vs. deformation response.

2.2.5 *Butler, Pal and Kulak*

A series of 13 tests were conducted by Butler, Pal, and Kulak (1972) on full-size eccentrically loaded fillet welded connections to investigate the behaviour of weld groups subjected to a combination of direct shear and moment. The test welds, made with E60XX electrodes and having a nominal leg dimension of 6.4 mm (1/4 in.), consisted of a central beam with two web angles (back to back) at each end. The legs of these web angles were connected by bolts to support arms and by fillet welds (the test welds) to the web of the beam. The central beam was a 0.6 m (2 ft.) long section cut from an S610x149 (S24x100) shape. Both the beam and the angles were A36 steel. Eight specimens had a vertical test weld only (weld length ranged from 203.2 mm to 406.4 mm (8 in. to 16 in.)) and the eccentricity of load varied from 152.4 mm to 406.4 mm (6 in. to 16 in.). The remaining five had the test weld around the angle in a C-shaped configuration. The length of the horizontal welds configuration was either 76.2 mm, 101.6 mm, or 152.4 mm (3 in., 4 in., or 6 in.), while the vertical leg varied from

152.4 mm to 304.8 mm (6 in. to 12 in.). The eccentricity of load (measured from the vertical weld) varied from 127.0 mm to 406.4 mm (5 in. to 16 in.).

A theoretical method was developed for predicting the ultimate loads of eccentrically loaded fillet welded connections. This method is based on the actual load-deformation response of elemental fillet weld segments and takes into account the variation in fillet weld strength with respect to the direction of the applied load. The model is based on the following assumptions:

1. The weld group, under an eccentric load, rotates about an instantaneous centre of rotation.
2. The deformation which occurs at any point in the weld group varies linearly with the distance from the instantaneous centre and acts in a direction perpendicular to a radius from that point.
3. The ultimate capacity of a connection is reached when the ultimate strength and deformation of some element of weld is reached.
4. The ultimate strength of a fillet weld subjected to a tension-induced shear is the same as for a similar weld loaded in compression-induced shear.
5. The line of action of the load is parallel to a principal axis of the weld group.

The theoretical method was verified by the test results and reasonable agreement was obtained.

2.2.6 Biggs, Crofts, Higgs, Martin, and Tzogius

The experimental results of fillet weld tests conducted by four of the individual authors, Biggs (1977), Crofts (1974), Higgs (1975), and Tzogius (1980), were summarized in Biggs *et al.* (1981) along with several theories for the prediction of strength. The specimens used by Biggs (1977) were cruciform configurations with transverse loading in two orthogonal directions. Crofts (1974) and Higgs (1975) used a beam-type loading arrangement which produced combinations of stresses in the longitudinal and transverse directions to the fillet weld axis. All three test programs used welds cut to 15 mm in length and machined to a uniform face profile having equal leg

lengths of 4 mm. Tzogius (1980) tested welds with several different lengths that were subjected to torsional and shear forces.

It was shown that the fracture angles varied for fillet welds subjected to different directions of load and relationships were presented for predicting the angle. An elliptical relationship of the average normal and shear stresses on the fracture plane was proposed. The theory was compared with the experimental results.

2.2.7 Swannell

The fundamentals of weld group design were reviewed by Swannell (1981a, 1981b). As a basis for the design of eccentrically loaded weld groups, idealized tri-linear load-deformation relationships were proposed for fillet welds at different angles to the direction of load. The relationships were based on the results of a series of tests conducted by the author on 6.35 mm (1/4 in.) welds and were compared and contrasted to those recommended earlier by Butler and Kulak (1971). An ultimate load model was then developed by assuming the initial position of an instantaneous centre of rotation associated with relative displacements between connected plates. By an iterative procedure, satisfying the equations of equilibrium with the specified applied load, the final position of the instantaneous centre can be found.

The model was used to predict the results of 21 tests conducted by the author on eccentrically loaded weld groups of different configurations. All welds had a 6.35 mm (1/4 in.) leg size. The model was also used to predict the results of the eccentrically loaded weld specimens reported by Butler *et al.* (1972) using both the load-deformation response for individual welds of Butler and Kulak (1971) as well as the tri-linear response proposed by the author. In most cases, the predictions of the model were in good agreement with the empirical studies.

2.2.8 Kamtekar

Kamtekar (1982) developed theoretical models, each based on an idealized three-dimensional equivalent force system, for predicting the strength of both transverse and longitudinal fillet welds. The models use a principal stress approach with the assumption that the weld metal obeys the von Mises yield criterion with the yield stress replaced by

the ultimate stress. Failure of the weld is assumed to occur on the plane of maximum shear stress. Longitudinal residual stresses were taken into consideration, but the small transverse residual stress was neglected. The analytical results were compared with the experimental results of Freeman (1931) and Kato and Morita (1969, 1974). The theoretical predictions were generally lower than the experimental results but were in most cases within 15%.

Kamtekar (1982) extended his model to account for welds with unequal legs. For transverse fillet welds, it was found theoretically that the plane of maximum shear stress is inclined at an angle of $(45 - \alpha)^\circ$ to the base plate, where α is the angle between the shear leg and the face of the weld, as shown in Figure 2.1. Also, for constant weld cross-sectional area, it was found that the applied load became the maximum when $\alpha = 30^\circ$. For longitudinal welds, the plane of maximum shear is the weld throat in all cases.

Based on his models for transverse and longitudinal welds, Kamtekar (1987) developed a general equation for predicting the capacity of fillet welds loaded in any direction:

$$P = \frac{\sigma_u dL}{\sqrt{6 - 3 \sin^2 \theta}} \quad [2.2]$$

where σ_u is the ultimate tensile strength of weld metal, d is the weld leg size, L is the weld length, and θ is the angle of the weld axis to the loading direction. This expression predicts that the load capacity of transverse fillet welds is 41% greater than that of longitudinal fillet welds. For stress-relieved transverse welds, the predicted capacity is 13% lower than for those with residual stresses, while the presence of residual stresses is predicted to have no effect for longitudinal welds. A general equation for predicting the capacity of stress-relieved fillet welds at any angle to the load direction was also presented:

$$P = \frac{\sigma_u dL}{\sqrt{6 - 2 \sin^2 \theta}} \quad [2.3]$$

This expression predicts that the load capacity of transverse fillet welds is 22% more than that of longitudinal fillet welds. The theoretical predictions were compared with the

experimental results of Butler and Kulak (1971), Clark (1971), and Swannell (1981) and reasonable agreement was found.

2.2.9 *Pham*

The effect of size on the static strength of transverse fillet welds on 36 IIW recommended cruciform specimens and longitudinal fillet welds on 36 Werner specimens were investigated by Pham (1983). The specimens were prepared with FCAW and SAW (submerged arc welding) process. Three nominal weld leg sizes were investigated: 6 mm, 10 mm, and 16 mm.

Considerable local plastic deformation was observed around the heat-affected zone of the transverse cruciform specimens. The failure loads indicated that the load capacity was primarily a function of the actual (including weld reinforcement and penetration) throat size. For the FCAW specimens, including transverse cruciform and longitudinal Werner specimens, there was a marked reduction in strength for welds having throats up to 8 mm (11.3 mm leg size), but there was no further reduction for larger welds. For longitudinal FCAW specimens, the failure surfaces were along the throat plane. Large longitudinal welds showed better ductility than small welds. This observation was the opposite of the results from cruciform specimens which have transverse welds.

2.2.10 *Kennedy and Kriviak*

A review of experimental results on the strength of fillet welds loaded in the longitudinal and transverse directions was conducted by Kennedy and Kriviak (1985). The authors argued that the vector sum approach for designing fillet welds wherein the strength of longitudinal welds is used as the limiting criterion is very conservative. In addition to presenting interaction equations proposed by others, two new interaction relationships were proposed for the design of fillet welds loaded in both the longitudinal and transverse direction simultaneously.

2.2.11 Mansell and Yadav

Mansell and Yadav (1982) reported the test results of a series of longitudinal and transverse fillet welds. Test specimens were the standard IIW (International Institute of Welding) specimens and were tested under tension and compression. Specimens were prepared using Australian E41 electrodes with a mean tensile strength of 558 MPa. It was reported that a variation of texture occurred on the fracture surfaces of transverse fillet weld specimens. The texture near weld root indicated that that portion was less ductile. Also the texture showed a varying degree of triaxiality of stress along the weld length. Size effect was also reported. Minor variations in weld size had no statistically significant effect on the average stress at fracture. However, the reduction in strength of larger welds was measurable.

2.2.12 Miazga and Kennedy

An experimental program was conducted by Miazga and Kennedy (1986, 1989). This experimental program included 42 fillet weld specimens prepared using E7014 electrodes and the SMAW process. Two weld leg sizes with seven loading angles ranging from 0° to 90°, with a 15° increment, were investigated. The specimens were designed to have the weld fracture before yielding of the plates. The ratio of the mean ultimate strength of the transverse to longitudinal fillet welds for the 5 mm and 9 mm welds were found to be 1.28 and 1.60, respectively. The higher strength in the transverse welds was attributed to the larger failure surface arising from the smaller fracture angle, and lateral restraint from base plate.

Miazga and Kennedy (1986) argue that the tensile strength of the weld metal at the weld root on an elastic base plate could be substantially higher than that obtained from the unrestrained all-weld-metal tension coupons because of the restraint in both directions perpendicular to the direction of load from the elastic base plate. The fracture surface of transverse welds was found to exhibit a transition from brittle fracture at the weld root to ductile fracture near the weld surface.

The fracture planes were not well-defined, but rather on uneven surfaces. For the specimens with 9 mm legs, made with three passes, and at loading angles of 30° to 90°, it

was observed that after initial cracking, the crack tended follow the weld pass interface. For the same type specimens with 0° and 15° loading angles, the cracks propagated across weld-pass interfaces. The average fracture angles were found to be 49° for longitudinal welds and 14° for transverse welds.

When normalizing the measured deformations by dividing by the gauge lengths, a non-dimensional quantity, strain, is obtained. By comparing the strains of fillet welds loaded at different angles, it was concluded that the ductility of the fillet weld is independent of the loading angle.

An analytical model was developed by Miazga and Kennedy (1986, 1989). The analytical results were compared with the experimental results of the 42 specimens. Three failure theories were used to predict the ultimate behaviour of fillet welds, namely maximum shear stress theory, maximum normal stress theory, and elastic strain energy of distortion theory. The maximum normal stress theory did not correlate well with the test results. The von Mises shear energy of distortion theory and the maximum shear stress theory were both in reasonable agreement with the test results. The von Mises theory predicted the fracture angles generally greater than those observed, especially for transverse fillet welds. The maximum shear stress theory predicted both ultimate loads and fracture angles well. This suggested that shear stress dominated the behaviour of fillet welds. The authors proposed an equation, based on the maximum shear stress theory, to predict the ratio the strength of a weld loaded at any angle to that of an equivalent longitudinal weld, as a function of the weld angle and the predicted fracture angle. The mean test/predicted ratio for the 42 tests was 1.004 with a coefficient of variation of 0.087.

2.2.13 Lesik and Kennedy

Lesik and Kennedy (1988, 1990) extended the work of Miazga and Kennedy (1989) to consider the strength of fillet welds loaded eccentrically in-plane using the method of instantaneous centre of rotation. A simplified expression to predict the strength of fillet welds loaded in various directions was developed:

$$P_{\theta} = P_0(1.00 + 0.50\sin^{1.5} \theta) \quad [2.4]$$

where P_θ is the load capacity of the fillet weld subjected to any direction of load, P_0 is the load capacity of an equivalent longitudinal fillet weld, and θ is the angle between the direction of load and the weld axis. In the previous version of CSA Standard S16.1, the load capacity of longitudinal fillet weld was:

$$P_0 = 0.67\phi A_w X_u \quad [2.5]$$

where ϕ is the performance factor, A_w is the theoretical throat area and X_u is the ultimate tensile strength of weld metal. By substituting [6] into [5], it became the current CSA Standard design equation:

$$P_\theta = 0.67\phi A_w X_u (1.00 + 0.50 \sin^{1.5} \theta) \quad [2.6]$$

This empirical expression is in good agreement with the theoretical relationship developed by Miazga and Kennedy, and predicts an increase in strength of 50% as the direction of load changes from longitudinal to transverse.

Two empirical equations:

$$\frac{\Delta_u}{d} = 0.209(\theta + 2)^{-0.32} \quad [2.7]$$

$$\frac{\Delta_f}{d} = 1.087(\theta + 6)^{-0.65} \quad [2.8]$$

were developed to predict fillet weld deformations as a function of the direction of load. Δ_u and Δ_f are the deformations at ultimate load and at failure, respectively. They are normalized by d , which is the leg size of the fillet weld.

2.2.14 Bowman and Quinn

A study of the influence of geometrical factors that influence the behaviour of fillet welds was presented by Bowman and Quinn (1994). This experimental program included 18 specimens, including longitudinal and transverse specimens with three leg sizes, 6.35 mm (1/4 in.), 9.53 mm (3/8 in.), and 12.7 mm (1/2 in.), and three different root gap configurations. The welds were prepared using E7018, low hydrogen, 4.76 mm

(3/16 in.) diameter electrodes. The ratio of strength of transverse/longitudinal fillet welds ranged from 1.3 to 1.7 for the ungapped specimens.

The shear stress was calculated as the failure load divided by the measured fracture surface area. It ranged from 85 to 99% of the average weld metal tensile strength, which is higher than the strength predicted by von Mises failure criterion. The average fracture angle was 15° and 60° for the transverse and longitudinal (ungapped) specimens, respectively. The fracture surfaces were not planar.

For transverse specimens, the larger welds did not demonstrate a significant decrease in strength. The 12.7 mm (1/2 in.) specimens showed only a 4.5% lower strength than the measured strength of the 6.35 mm (1/4 in.) specimens. For the longitudinal specimens, the larger welds did demonstrate a significant decrease in strength. The authors argued that the reduction of strength was not strictly due to the increase in leg size, but the fact that larger welds tend to have a less convex profile also contributed. Large transverse welds did not show significant reduction in strength because transverse welds failed at a smaller angle where the weld reinforcement was small for every size of weld. It was concluded also that the dimple in the exposed weld profile of multi-pass welds contributed to the reduction of strength in longitudinal welds.

2.2.15 Iwankiw

A rational basis for increased fillet weld strength of transverse over longitudinal welds was derived from first principles by Iwankiw (1997). An analytical first order derivation of the general fillet weld strength as a function of the direction of load was based on the three-dimensional equilibrium of the theoretical throat, and assuming equal weld leg size. An expression of fillet weld load capacity as a function of the direction of load was presented:

$$P_{\theta} = P_0 \sqrt{\frac{2}{(2 - \sin^2 \theta)}} \quad [2.9]$$

The ratio of P_{θ} / P_0 predicted by Equation 2.9 was compared with the one predicted by AISC LRFD Specification (AISC 1999) Appendix J2.4, which is also shown herein as Equation 2.4. The predictions of Equation 2.9 were always lower than those of AISC

Appendix J2.4. Equation 2.9 predicted that the load capacity for a fillet weld loaded transversely is 41% higher than one loaded longitudinally.

2.3 Summary

Fillet weld behaviour has been investigated using experimental and theoretical approaches in many studies. Transverse, longitudinal, and fillet welds with intermediate loading angles have been studied. It is widely accepted that the capacity of fillet welds is a function of the direction of the applied load. As the angle between the direction of load and the weld axis increases, the capacity of fillet welds increases.

This literature review shows that the majority of transverse fillet weld tests were conducted on welds made with SMAW filler metals. Only a few recent research programs used fillet welds made with FCAW electrodes. Test results of fillet welds made with filler metals with a specified toughness requirement are not available in the literature and the level of toughness of the filler metals used is seldom evaluated. In general, transverse fillet weld test results presented in the literature were mainly conducted on fillet welds with a lapped splice configuration; results for fillet welds in weldments having a cruciform configuration are very limited. The behaviour of fillet welds at low service temperature was not investigated in any of the previous studies. Moreover, it is found that test results of fillet welds with base plates that yielded prior to weld fracture are not available.

In order to expand the pool of data on transverse fillet welds to include data for FCAW filler metals and filler metals with a toughness requirement, an experimental program on fillet welds made with these filler metals is needed. As the root notch orientation of cruciform configured weldments may influence the fillet welds behaviour, there is a need to test cruciform splices. The effect of low temperature on the behaviour of fillet welds was not determined in the previous studies, so an investigation of fillet welds tested at low temperature is needed. The restraint from an elastic base plate may result in welds with higher strength than those with plates that yield prior to weld fracture. Therefore, tests of fillet welds on base plates that have yielded before weld fracture is also need.

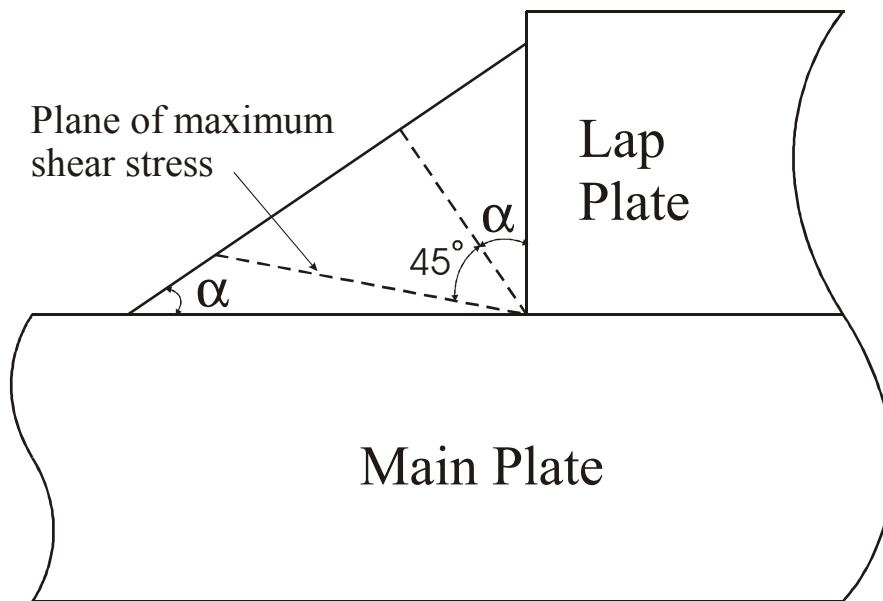

**Figure 2.1 – Plane of Maximum Shear Stress of Unequal Leg Fillet Weld
(after Kamtekar 1982)**

3. EXPERIMENTAL PROGRAM

3.1 Test Specimens

3.1.1 General

Five classifications of filler metal (E7014, E70T-4, E70T-7, E70T7-K2, and E71T8-K6) and two different welding processes (FCAW and SMAW) were used to produce the test specimens, resulting in a total of 102 fillet weld specimens. Two fillet weld specimen configurations (double lapped splice and cruciform) are included in this study. All-weld-metal and base plate tension coupons, and Charpy V-notch coupons were fabricated to determine the material tensile properties and fracture toughness. Chemical pads for each classification of filler metal were also prepared for chemical analysis. All base plates were supplied by the same fabricator and welds for each type of filler metal were made by both steel fabricators from the same spool of electrode wire to ensure that the steel fabricator would be the only parameter of variation for cases having the same filler metal classification and manufacturer.

Two steel fabricators (welders) and the products of two welding electrode manufacturers were used to produce the test specimens for this research. The steel fabricators were Waiward Steel Fabricators Ltd. (W) and Supreme Steel Ltd. (S), both of Edmonton, Alberta, Canada. The electrode manufacturers were Hobart Brothers Co. (H) and Lincoln Electric Co. (L). In most tables and graphs, the company names are identified only by the letter designations shown above in brackets. Throughout this report, the names of the companies have been abbreviated to Waiward, Supreme, Hobart, and Lincoln, respectively, for brevity.

Test specimens are identified alphanumerically. T stands for transverse lapped splice specimen, C stands for cruciform specimen, and A stands for ancillary test specimen. The number immediately after the letter is the assembly number and the last number (following a hyphen) is the specimen number of the assembly. For example, T2-1, is the first lapped splice specimen from assembly 2. Due to the relatively large number of variables involved, for convenience each specimen has been assigned an identifier in the form E7XXX(M)F S, where E7XXX is the filler metal classification.

Although the SI system of units is the primary system used in this report, AWS designations for filler metal classifications are used for reasons of familiarity and readability. E7XXX filler metals are equivalent to Canadian E49XX filler metals, as specified in CSA-W48 (CSA 2001). The letter inside the brackets indicates the electrode manufacturer (H for Hobart and L for Lincoln). The letter immediately after the brackets indicates the steel fabricator (W for Waiward and S for Supreme). The specified fillet weld leg size, in millimeters, follows.

3.1.2 Filler Metals

The first type of filler metal (E7014) is a shielded metal arc welding (SMAW) electrode and the rest are flux cored arc welding (FCAW) electrodes. The first three have no specified toughness requirement, while the fourth and fifth (E70T7-K2 and E71T8-K6) have a specified toughness requirement of 27 J (20 ft-lbf) at -29°C (-20°F). Welding electrodes are from two electrode manufacturers, namely, Hobart and Lincoln. A single electrode classification could not be used for filler metals with a specified toughness for direct comparison because the two wire manufacturers did not offer products with the same conformance. However, in consultation with AISC Task Committee 7, E70T7-K2 and E71T8-K6 electrodes were deemed to be equivalent for the purposes of this study. Table 3.1 shows a description of the filler metals used, including the lot numbers of the spools.

3.1.3 Base Plates

All plates were specified to meet the requirements of CSA-G40.21 grade 350W (or ASTM A572 grade 50) steel. In the case of the 6.4 mm (1/4 in.) leg fillet weld specimens made using E7014 electrode, plates were designed to remain elastic during the tests for consistency with the tests conducted by Miazga and Kennedy (1986). In the other cases, plate thicknesses and heats were selected so that the plate would yield prior to fracture of the welds in order to minimize the amount of restraint to the weld region near the ultimate load.

3.1.4 Fillet Weld Specimens

Table 3.2 shows a description of the test matrix of this research. In every case, three nominally identical specimens were cut from a single assembly, then milled to a width of 76 mm (3 in.). The assemblies provided generous run-on and run-off regions in order to provide uniform weld quality within the test specimens. Ninety-six test specimens were fabricated as double lapped splice joints, as shown in Figure 3.1a, and six specimens were fabricated in a cruciform configuration, as shown in Figure 3.1b. Because it was believed that the root notch orientation might influence the behaviour of fillet welded connections, the latter specimens were prepared to investigate the weldment geometry. In order to reduce both the preparation time and the amount of required instrumentation, two welds from each specimen were reinforced to ensure failure would occur in one of the two test welds, as indicated in Figure 3.1.

3.1.5 Ancillary Test Specimens

All-weld-metal tension coupons, Charpy V-notch impact test specimens, and chemical pads were fabricated for all types of filler metal and by both fabricators, except that chemical pads were produced only by Waiward. The weld metal tension coupons and Charpy V notch impact specimens were machined from a standard groove welded assembly fabricated in accordance with Clause 8 of ANSI/AWS A5.20 (AWS 1995) for the FCAW specimens and Clause 8 of ANSI/AWS A5.1 (AWS 1991) for SMAW specimens. Both the tension and impact specimens were prepared—and the tests carried out—in accordance with ASTM standard A370 (ASTM 1997). The chemical pads, prepared in accordance with Clause 9 of ANSI/AWS A5.20 (AWS 1995) and ANSI/AWS A5.1 (AWS 1991), were deposited so that analyses could be carried out to determine whether the chemical compositions meet the requirements of the applicable AWS specifications. The ancillary specimens were produced using the welding wire from the same spools as for the fillet weld specimens.

Although the precise properties of base metal are not considered to affect the behaviour of fillet weld significantly, full thickness material tension coupons were prepared to confirm compliance with the standard. Two tension coupons were prepared

for each nominal plate thickness resulting in a total of eight coupons. The tests were conducted in accordance with ASTM standard A370 (ASTM 1997).

As shown in Table 3.2, two weld metal tension coupons were prepared for each type of filler metal, except in the case of the E70T-4 filler metal produced by Hobart and deposited by Waiward. In this special case, five coupons (three from one assembly and two from another) were prepared to assess the repeatability of the results. Six Charpy impact V notch specimens were prepared for each type of filler metal for testing at three different temperatures, namely, -29°C, 21°C and 100°C (two coupons at each temperature). The lowest temperature is the temperature at which the E70T7-K2 and E71T8-K6 weld metals have a toughness requirement of 27 J specified by the standard (AWS 1998). The highest temperature provides an estimate of the upper shelf toughness.

Rockwell B and C hardness tests were conducted on some fillet welds, both prior and subsequent to failure in the transverse tension tests. For comparison of the effect on hardness (generally considered to be closely associated with tensile strength) of the two distinctly different welding procedures, hardness tests were also conducted on some Charpy V-notch impact test coupons cut from the groove welded assembly.

3.1.6 Specimen Fabrication

Waiward used an automated welding track (Figures 3.2a) and Supreme used a semi-automatic process (Figure 3.2b) to produce the fillet weld specimens in order to emphasize the differences that might occur between two steel fabricators. All specimens were welded in horizontal position. Fillet welds with 6.4 mm legs were welded in a single weld pass, and those with 12.7 mm legs were welded in three passes. The welding procedure specifications used by both Waiward and Supreme are shown in Tables A1 and A2, respectively, of Appendix A. Weld root penetration and the extent of fusion were determined by etching selected specimens for visual examination. Photographs of the etched sections are shown in Appendix B. In general, good weld penetration was revealed.

Figure 3.2c shows the welding of a cruciform specimen in progress. Figure 3.2d shows the plate assemblies used for producing the all-weld-metal tension coupons and the

Charpy V-notch impact test specimens. The preset that can be seen in the photograph offsets the weld shrinkage.

3.2 Transverse Fillet Weld Experimental Program

3.2.1 Preparation of Specimens

Detailed pre-test measurements were performed on each specimen. The dimensions of the weld legs and throat of both test welds were measured at eight locations along the weld length. Leg dimensions were measured using a digital caliper. The throat thickness was measured with an adjustable fillet weld gauge at an angle of 45° from the base plate. For the 12.7 mm welds, measurements were taken at an additional two locations parallel to the throat dimension, as shown on Figure 3.3. A summary of the average dimensions of each fillet weld is presented in Table 3.3. The detailed dimensions and plots of individual weld profiles are presented in Appendix C to give an indication of the variability of weld size and of the amount of weld reinforcement.

3.2.2 Test Setup

The test set-up, illustrated in Figure 3.4, consisted of a standard tension testing machine with 1750 kN capacity, four linear variable differential transducers (LVDTs), four LVDT brackets, the test specimen itself, and an electronic data acquisition system. Two LVDTs were mounted on each test weld to measure the deformation of the weld, except for four cruciform specimens. (It was discovered that the initial out-of-straightness of the cruciform specimens resulted in significant bending that caused unequal loading in the two test welds. In order to obtain the average response of the two test welds, one LVDT was placed on each edge of the specimen, at the end of the test welds. The set-up of these cruciform specimens is shown in Figure 3.4b). LVDTs were held in place by customized brackets (Figure 3.4c) that were developed as part of this research project. The brackets were designed to ensure that the displacement measurements include the deformation within the leg dimension and minimize the amount of plate deformation captured. This design was important because the base plates were designed to yield prior to weld fracture. The two hardened steel anchors installed at the front of each bracket were set in two light punch marks on the surface of the base plate right at the toe of the

weld and held securely with heavy elastic bands. The rear of each bracket had two integrated steel rollers to stabilize the assembly and eliminate the longitudinal restraint due to the relatively large base plate deformation.

3.2.3 Test Procedure

The tests were conducted quasi-statically and static readings were taken at multiple points during the tests. The electronic data acquisition system provided a real time plot of the load vs. weld deformation curve at each LVDT location and of the load vs. overall deformation curve for the whole specimen to facilitate the control of testing. All the instrumentation was kept in place right up to the fracture of the first test weld in order to acquire the full response curves. The instrumentation was then removed and the second test weld was loaded to failure to facilitate removal from the testing machine. Although the second weld was not instrumented beyond the point when the first weld fractured, in this range the loading of the remaining weld is considered non-representative due to the asymmetric connection geometry. In any case, the important data were obtained to very near the fracture point of the second weld. The specimen was then removed from the testing machine carefully to avoid any damage to the fracture surface.

The fracture surfaces of some of the welds were examined under a scanning electron microscope to determine the nature of the fracture process (ductile or brittle fracture) at various locations on the fracture surface. The photomicrographs are presented in Appendix H. Detailed post-test measurements were performed on every fracture surface to determine the fracture angle and the dimensions of the fracture surface, including the root penetration, at eight locations along the weld length. The fracture angles were measured with a vernier bevel protractor.

3.2.4 Tests at -50 °C

Three lapped splice specimens were tested at -50°C according to the procedures described in Section 3.2.3. A customized chamber (Figure 3.5) was fabricated from rigid insulation to fit the specimen and dry ice was placed inside to lower the temperature. The chamber was equipped with several Plexiglas windows to permit visual inspection of the

specimens during testing without opening the chamber. The temperature of specimen was controlled by continually adjusting the speed of two small fans that were installed in the chamber to blow cold air toward both test welds. The surface temperature of the test welds was monitored by thermocouples throughout the test, and the temperature was controlled within a good degree of accuracy (approximately $\pm 3^{\circ}\text{C}$).

3.3 Summary

A total number of 102 fillet weld specimens were tested. They were produced using five classifications of filler metal (E7014, E70T-4, E70T-7 E70T7-K2, and E71T8-K6) and two welding processes (FCAW and SMAW). Filler metals were produced by two electrode manufacturers (Hobart and Lincoln) and test specimens were fabricated by two steel fabricators (Waiward and Supreme). Fillet weld specimens consisted of two configurations, namely double lapped splice and cruciform configurations. All-weld-metal tension coupons and Charpy V-notch impact test coupons were fabricated to determine the material properties and fracture toughness. Chemical pads for each classification of filler metal were prepared for chemical analysis. All base plates were specified to meet the CSA-G40.21 grade 350W (ASTM A572 grade 50) steel requirement. All plates were selected to yield prior to fracture of the test weld in order to minimize the amount of restraint to the weld region except for the case of 6.4 mm leg fillet weld made using E7014 filler metal, because a direct comparison would be made with the results from Miazga and Kennedy (1986). Base plate material tension coupons were also fabricated to determine the material properties. In order to ensure that the steel fabricator would be the only parameter of variation for cases having the same filler metal classification and manufacturer, all base plates were supplied by the same fabricator and welds for each type of filler metal were made by both steel fabricators from the same spool of electrode wire.

Detailed measurements of each test weld were conducted before testing. The leg dimensions of both legs and throat thickness of each test weld were measured at eight locations along the weld length. The throat thickness of 6.4 and 12.7 mm fillet weld was measured at one and three locations parallel to the throat dimension, as shown on Figure 3.3. Detailed measurements of fracture surface dimensions were performed after

weld fracture. These measurements include weld root penetration and weld reinforcement. Visual examinations to determine weld root penetration and the extent of fusion were performed on a selected series of etched specimens. The test set-up consisted of a standard tension testing machine with 1750 kN capacity, four LVDTs, four LVDT brackets, the test specimen itself, and an electronic data acquisition system which can provide real time load-deformation plot. Each LVDT was clamped in a LVDT bracket and the brackets were mounted at the weld toe to measure the weld deformation. The brackets were designed to minimize the amount of plate deformation captured. Three double lapped splice specimens were tested at -50°C to investigate the behaviour of fillet weld at low temperature. The temperature was controlled approximately within $\pm 3^{\circ}\text{C}$.

Table 3.1 – Description of Flux-Cored Arc Welding Electrodes

AWS Classification	Electrode Manufacturer	Proprietary Designation	Lot Number
E70T-4	Hobart	Fabshield 4	04-24-250C 54208B0661
E70T-4	Lincoln	Innershield NS3M	2A15SA
E70T-7	Hobart	Fabshield 7027	S222729-014 F00836-001
E70T-7	Lincoln	Innershield NR311	11G27AN
E71T8-K6	Hobart	Fabshield 3Ni1	S226625-029 E11187-001
E70T7-K2	Lincoln	Innershield NR311Ni	3A30TG

Table 3.2 – Matrix of Test Specimens

Waiward

Filler Metal Classification	E70T-4				E70T-7				E71T8-K6 / E70T7-K2				E7014	
Electrode Manufacturer	H		L		H		L		H		L		L	
Weld Size (mm)	6.4	12.7	6.4	12.7	6.4	12.7	6.4	12.7	6.4	12.7	6.4	12.7	6.4	12.7
No. of Specimens	12*	3	3	3	3	3	3	3	3	3	6*	3	9	3
No. of Charpy Tests	3 x 2		3 x 2		3 x 2		3 x 2		3 x 2		3 x 2		3 x 2	
No. of Material Tension Tests	5		2		2		2		2		2		2	

* Includes three cruciform specimens

Supreme

Filler Metal Classification	E70T-4				E70T-7				E71T8-K6 / E70T7-K2			
Electrode Manufacturer	H		L		H		L		H		L	
Weld Size (mm)	6.4	12.7	6.4	12.7	6.4	12.7	6.4	12.7	6.4	12.7	6.4	12.7
No. of Specimens	3**	3	6	3	3	3	6	3	3	3	3	3
No. of Charpy Tests	3 x 2		-		-		3 x 2		3 x 2		-	
No. of Material Tension Tests	2		-		-		2		2		-	

** Tested at -50°C

Table 3.3 – Mean Fillet Weld Dimensions**6.4 mm Lapped Splice Specimens**

Specimen Designation	Front Side				Back Side			
	Shear Leg (mm)	Tension Leg (mm)	45° Meas. (mm)	Weld Length (mm)	Shear Leg (mm)	Tension Leg (mm)	45° Meas. (mm)	Weld Length (mm)
T1-1	6.5	6.6	5.7	76.0	5.7	6.3	5.2	76.2
T1-2	6.5	6.2	5.5	76.1	6.2	5.9	5.3	76.2
T1-3	6.0	6.5	5.0	76.2	6.0	6.6	5.1	76.0
T2-1	5.5	6.2	4.1	76.2	6.6	6.1	4.4	76.2
T2-2	6.0	6.1	4.4	76.1	6.1	6.2	4.3	76.2
T2-3	6.1	6.7	4.7	76.1	6.4	5.8	4.6	76.2
T3-1	7.5	6.6	5.4	76.0	7.9	7.4	5.2	76.1
T3-2	8.0	6.8	5.4	76.1	8.2	7.2	5.3	76.0
T3-3	7.6	7.3	5.4	76.0	7.9	6.9	5.3	76.0
T4-1	5.9	6.2	5.4	76.2	6.1	6.1	5.5	76.1
T4-2	6.1	6.4	5.4	76.1	6.3	6.1	5.6	76.1
T4-3	6.0	6.3	5.2	76.1	6.0	6.0	5.5	76.1
T5-1	6.4	5.8	4.8	76.1	6.0	6.1	5.0	76.0
T5-2	6.5	5.8	4.9	75.9	6.3	6.2	5.0	76.0
T5-3	6.3	5.8	4.9	75.9	5.8	5.9	4.7	76.0
T6-1	6.6	5.1	4.6	75.9	6.5	5.5	4.7	76.0
T6-2	6.3	5.7	4.7	76.0	6.7	5.1	4.4	76.0
T6-3	6.5	5.8	4.8	75.9	6.5	5.4	4.5	76.0
T7-1	6.5	5.8	4.8	75.9	6.5	5.4	4.5	76.0
T7-2	5.1	4.5	3.9	76.2	5.9	4.4	4.0	76.1
T7-3	5.2	4.5	4.2	76.1	5.6	4.7	4.4	76.1
T8-1	5.9	7.3	5.8	75.6	6.5	7.6	6.2	75.4
T8-2	6.0	7.7	6.1	75.5	6.5	7.3	6.1	75.5
T8-3	6.5	7.8	6.2	76.3	6.9	7.1	6.1	76.4
T9-1	7.4	6.0	5.6	76.0	8.6	5.8	5.5	76.1
T9-2	8.2	5.6	5.3	76.1	8.3	6.1	5.3	76.0
T9-3	8.3	6.1	6.0	76.0	8.0	6.1	5.6	76.0
T10-1	7.7	6.6	5.9	76.0	8.8	6.6	6.5	76.1
T10-2	7.9	6.3	5.8	76.0	8.2	6.3	6.1	76.1
T10-3	7.8	6.3	6.1	76.0	8.6	6.6	6.1	76.0
T11-1	6.4	6.7	6.2	76.1	7.6	6.8	6.3	76.1
T11-2	6.7	7.2	6.3	76.1	7.1	6.8	5.9	76.0
T11-3	6.5	7.2	6.2	76.2	7.1	6.9	6.3	76.1
T12-1	7.9	6.3	6.1	76.1	7.8	5.4	5.1	76.1
T12-2	8.0	5.9	5.7	75.9	7.8	5.1	5.1	75.9
T12-3	7.5	6.2	5.7	76.1	8.2	5.4	5.1	76.0
T13-1	6.7	5.2	4.8	75.9	6.8	6.6	4.8	75.9
T13-2	6.5	6.0	5.1	76.0	7.3	5.9	5.5	76.1
T13-3	6.2	5.6	4.9	76.0	5.5	5.8	5.0	75.9
T14-1	8.2	6.8	6.2	76.0	8.7	6.9	6.0	76.0

Table 3.3 – Mean Fillet Weld Dimensions (Cont.)

6.4 mm Lapped Splice Specimens

Specimen Designation	Front Side				Back Side			
	Shear Leg (mm)	Tension Leg (mm)	45° Meas. (mm)	Weld Length (mm)	Shear Leg (mm)	Tension Leg (mm)	45° Meas. (mm)	Weld Length (mm)
T14-2	8.3	6.8	5.9	76.1	8.7	6.7	5.8	76.1
T14-3	7.9	6.9	6.1	76.0	8.5	6.6	5.9	76.0
T15-1	6.8	6.7	5.5	76.1	7.7	6.8	6.3	76.1
T15-2	7.4	7.3	5.9	76.0	7.7	7.3	6.2	76.0
T15-3	7.2	7.0	5.8	76.1	7.5	7.1	6.2	76.1
T16-1	6.7	7.1	5.4	76.2	7.7	7.5	6.5	76.2
T16-2	6.7	6.8	5.4	76.2	8.1	7.9	6.5	76.2
T16-3	6.9	7.1	5.4	71.7	7.2	6.5	5.8	71.6
T17-1	9.0	5.1	5.0	76.1	9.2	5.4	5.4	76.1
T17-2	9.6	4.2	4.5	76.2	9.1	6.3	5.9	76.1
T17-3	9.8	4.4	4.7	76.2	8.4	6.6	6.0	76.1
T18-1	5.5	6.5	5.0	75.9	5.7	6.4	5.2	75.8
T18-2	5.2	6.9	5.0	75.9	5.3	6.1	5.1	75.9
T18-3	5.7	7.0	5.1	75.9	5.3	6.4	5.1	75.9
T19-1	8.1	6.9	5.4	76.1	7.8	6.8	5.6	76.1
T19-2	8.8	7.6	5.8	76.0	8.1	6.0	5.5	76.0
T19-3	8.7	7.2	5.6	75.9	8.0	6.2	5.6	76.0

12.7 mm Lapped Splice Specimens

Specimen Designation	Front Face						Back Face					
	Shear Leg (mm)	Tension Leg (mm)	45° Measurements			Weld Length (mm)	Shear Leg (mm)	Tension Leg (mm)	45° Measurements			Weld Length (mm)
			Upper (mm)	Throat (mm)	Lower (mm)				Upper (mm)	Throat (mm)	Lower (mm)	
T20-1	13.4	14.2	4.7	9.8	5.6	75.8	13.3	13.7	4.9	10.3	6.3	75.8
T20-2	12.8	13.2	4.0	9.2	5.1	76.0	13.4	14.6	4.7	9.6	5.8	75.9
T20-3	13.3	14.1	5.4	10.1	5.5	76.0	13.9	13.6	4.3	9.4	5.6	76.2
T21-1	11.3	14.0	6.6	11.1	4.7	76.3	12.2	13.1	7.3	11.6	5.9	76.2
T21-2	12.2	13.7	6.4	11.3	5.2	76.3	12.1	13.7	7.6	12.1	5.8	76.1
T21-3	12.1	13.5	6.4	10.9	5.2	76.2	12.2	13.5	7.1	11.7	5.8	76.1
T22-1	9.4	10.6	3.6	7.8	3.2	76.2	11.1	11.9	4.8	9.2	4.2	76.1
T22-2	10.3	10.0	3.3	8.0	3.6	76.1	10.8	11.5	4.9	9.0	4.0	76.1
T22-3	11.1	10.1	3.4	8.4	4.2	76.0	10.1	11.6	4.4	8.5	3.3	76.1
T23-1	12.6	12.8	5.2	10.2	4.8	76.1	13.5	13.0	5.1	10.0	5.1	76.1
T23-2	12.5	12.7	5.3	10.5	5.1	75.9	13.4	13.0	5.2	10.2	5.0	76.2
T23-3	12.7	13.3	5.5	10.5	5.1	76.1	13.2	12.8	5.0	9.9	4.9	75.9
T24-1	11.6	10.9	3.5	8.2	3.7	76.2	11.7	11.8	4.2	8.6	4.1	76.1
T24-2	12.7	10.5	3.4	8.4	4.2	76.1	12.0	11.4	4.4	8.9	4.3	76.0

Table 3.3 – Mean Fillet Weld Dimensions (Cont.)

12.7 mm Lapped Splice Specimens

Specimen Designation	Front Face						Back Face					
	Shear Leg (mm)	Tension Leg (mm)	45° Measurements			Weld Length (mm)	Shear Leg (mm)	Tension Leg (mm)	45° Measurements			Weld Length (mm)
			Upper (mm)	Throat (mm)	Lower (mm)				Upper (mm)	Throat (mm)	Lower (mm)	
T24-3	13.4	10.7	3.4	8.4	4.2	76.0	12.0	11.1	3.8	8.2	4.1	76.1
T25-1	13.8	11.4	4.6	9.5	5.6	76.0	14.8	10.7	4.3	10.2	5.9	76.1
T25-2	12.3	11.8	4.5	9.1	4.8	76.0	12.4	11.4	4.7	9.4	4.9	76.1
T25-3	13.7	11.7	4.8	9.7	5.2	75.9	13.3	10.9	4.3	9.5	5.1	76.0
T26-1	12.4	11.6	4.8	9.5	4.9	76.0	13.2	10.6	3.7	9.0	4.8	76.3
T26-2	12.4	11.9	4.9	9.5	5.0	75.9	12.7	11.2	4.4	9.2	4.8	76.1
T26-3	13.0	11.7	4.6	9.3	5.1	76.2	13.0	11.6	4.4	9.3	5.0	76.2
T27-1	12.8	11.4	3.3	8.0	3.6	76.3	11.6	12.1	4.0	8.4	3.9	76.1
T27-2	12.5	11.8	3.7	8.3	3.8	76.3	11.8	12.0	3.7	8.3	3.6	76.2
T27-3	12.2	12.1	3.9	8.4	3.8	76.1	11.6	11.8	3.5	8.4	3.4	76.2
T28-1	13.8	10.6	3.6	8.9	4.8	76.1	12.5	10.7	3.6	8.3	4.2	76.2
T28-2	13.3	10.7	4.0	9.1	5.0	76.2	12.2	10.8	3.7	8.3	4.1	76.1
T28-3	13.0	11.2	4.1	9.0	4.9	76.1	12.9	10.9	3.7	8.4	4.1	76.0
T29-1	12.7	12.0	5.2	10.2	5.0	76.1	16.3	12.6	4.8	9.3	5.8	76.1
T29-2	13.4	12.8	5.5	10.3	5.1	76.0	16.8	12.2	4.6	9.3	5.7	76.1
T29-3	16.0	12.0	4.8	9.7	5.8	76.0	13.4	13.7	6.0	10.7	5.4	76.0
T30-1	12.7	11.2	3.8	8.8	4.4	76.2	13.1	10.3	3.4	8.5	4.7	76.2
T30-2	12.6	10.3	3.3	8.8	4.7	76.1	13.7	9.6	3.0	8.5	4.5	76.0
T30-3	12.3	10.4	3.4	8.2	4.7	76.0	13.2	10.3	3.3	8.3	4.7	76.0
T31-1	11.5	10.7	3.9	8.7	4.2	76.1	10.5	12.4	4.9	9.4	4.3	76.2
T31-2	11.4	11.8	4.3	8.8	4.3	76.2	10.7	12.1	4.8	9.3	4.2	76.2
T31-3	11.4	12.4	4.8	9.4	4.3	76.1	10.3	11.4	4.4	9.3	3.9	76.1
T32-1	12.3	11.2	4.1	8.8	4.3	76.0	12.2	12.7	4.8	8.9	4.4	76.2
T32-2	11.4	11.7	4.4	9.1	4.6	76.1	12.1	12.7	4.7	9.0	4.7	76.1
T32-3	10.5	12.9	5.0	8.7	4.1	76.0	12.2	11.8	4.4	9.0	4.6	76.1

Cruciform Specimens

Specimen Designation	Front Side				Back Side			
	Shear Leg (mm)	Tension Leg (mm)	45° Meas. (mm)	Weld Length (mm)	Shear Leg (mm)	Tension Leg (mm)	45° Meas. (mm)	Weld Length (mm)
C1-1	7.2	5.1	5.5	75.5	7.8	6.1	5.6	75.5
C1-2	7.3	5.1	5.5	76.1	7.7	6.4	5.6	76.1
C1-3	6.7	5.5	5.5	75.0	7.7	6.4	5.6	75.1
C2-1	5.8	6.5	5.5	75.8	7.4	6.5	5.6	75.8
C2-2	7.7	5.7	5.5	75.9	5.9	7.0	5.6	75.8
C2-3	7.3	5.6	5.5	76.2	5.8	7.7	5.6	76.2

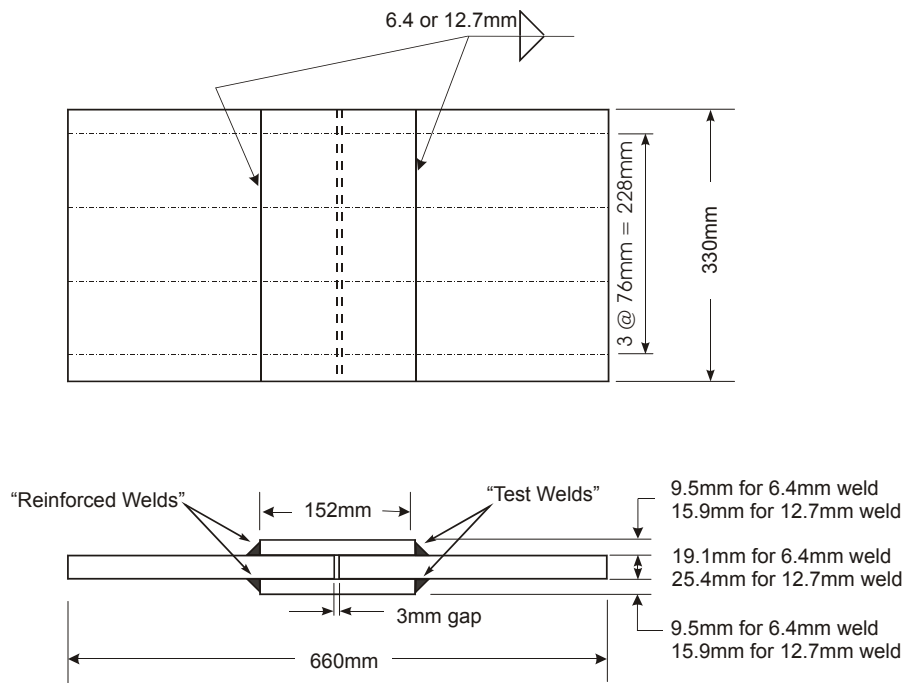

(a) Lapped Splice Specimens

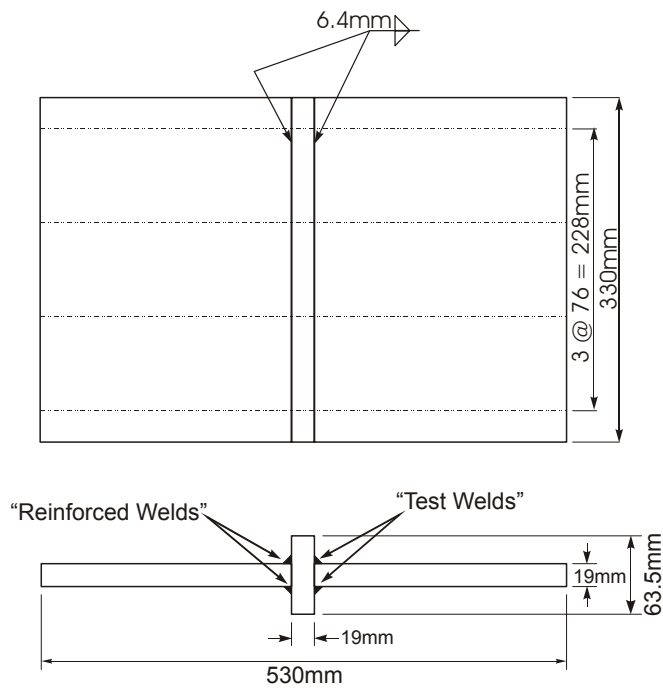

(b) Cruciform Specimens

Figure 3.1 – Transverse Fillet Weld Test Specimens

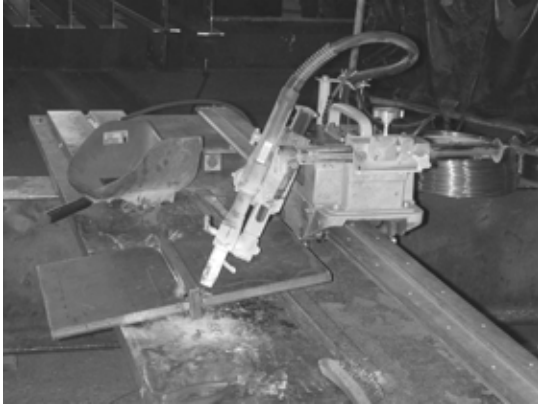

(a) Welding using a welding track



(b) Semi-automatic welding



(c) Welding of cruciform specimen



(d) All-weld test specimens before welding

Figure 3.2 – Fabrication of Test Specimens

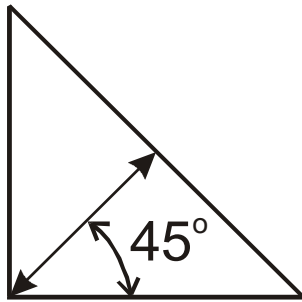

(a) 6.4 mm Fillet Weld

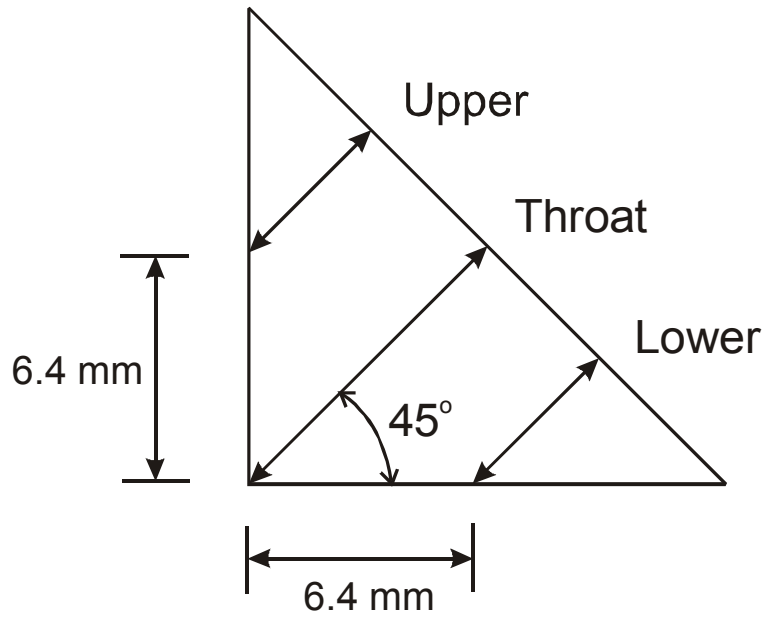

(b) 12.7 mm Fillet Weld

Figure 3.3 – Pre-test Fillet Weld Throat Measurements

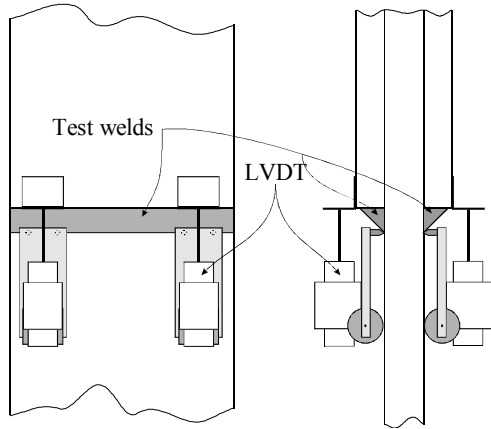

(a) Lapped Splice Specimen

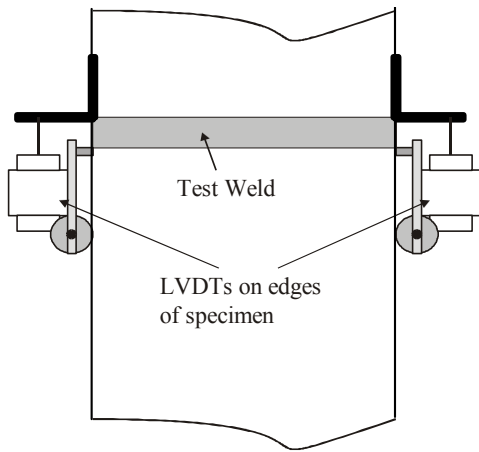

(b) Cruciform Specimen

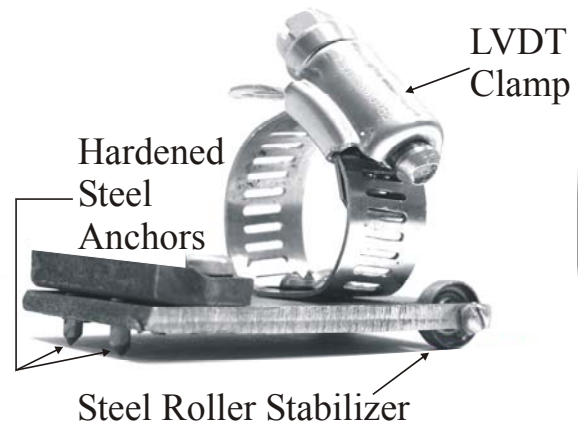

(c) LVDT Bracket

Figure 3.4 – Test Set-up and Instrumentation

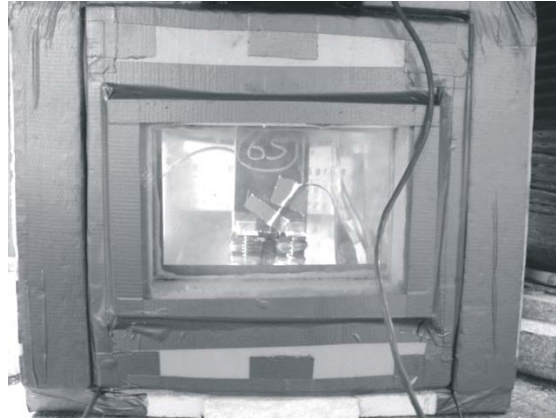

(a) Cold Chamber

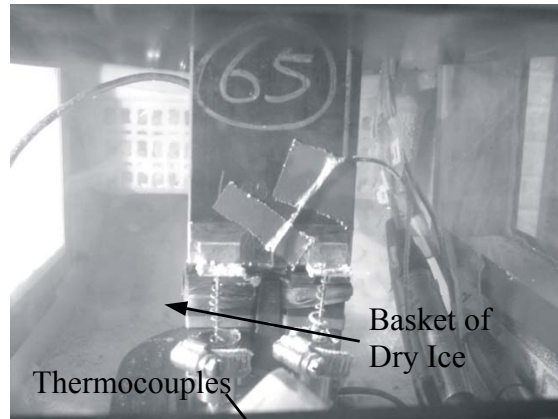

(b) Test Specimen at -50°C

Figure 3.5 – Lapped Splice Specimen Test at -50°

4. TEST RESULTS

4.1 All-Weld-Metal Tension Coupon Tests

A total of 23 all-weld-metal tension coupon tests were conducted and a summary of the test results is presented in Table 4.1. The results presented in the table are the mean values of all tests on coupons with the same combination of parameters. Detailed results and stress vs. strain curves are reported in Appendix D. Three coupons failed prematurely, as indicated in the table. The mean static tensile strengths and mean percent elongations shown exclude these three prematurely failed coupons, although they are included in the mean values for the static yield strength and the modulus of elasticity. Elongations were measured from a 50 mm gauge length and the static yield strengths were obtained at 0.2% strain offset. All coupons made with filler metal without a specified toughness requirement met the required minimum tensile strength of 480 MPa, but the amount of excess strength varied widely. All coupons made with filler metal with a specified toughness requirement exhibited a static tensile strength within the required lower and upper limits of 480 MPa and 620 MPa, respectively. All coupons met the required minimum static yield strength of 400 MPa, except the E70T-4 coupons from one wire manufacturer and made by one fabricator (assembly A2) as well as one individual E71T8-K6 coupon (from assembly A10). The minimum percent elongation specified for the E7014 electrodes (SMAW) is 17% and for the FCAW electrodes considered in this study with and without a specified toughness requirement are 20% and 22%, respectively. In addition to the three coupons that fractured prematurely, two coupons (both E70T-4 from Hobart; one from each fabricator) exhibited ductility slightly lower than the minimum percent elongation requirement.

4.2 Base Plate Tension Coupon Tests

A summary of the results from eight base plate tension coupon tests is given in Table 4.2. In the table, the mean values of the test results on identical coupons are presented. Detailed results and stress vs. strain curves are presented in Appendix D. The static yield strengths were determined from three measurements on the yield plateau and elongations were measured on a 50 mm gauge length. All results satisfied the required

minimum static yield and static tensile strength of ASTM A572 grade 50 (ASTM 2000) structural steel of 345 MPa and 450 MPa, respectively. The percent elongations also satisfied the minimum requirement of 21%.

4.3 Charpy V-notch Impact Tests

The Charpy V-notch impact test results are presented in Table 4.3. The E7014 (SMAW) filler metal had higher impact energies than the FCAW filler metals without a specified toughness requirement at all three temperatures. The E70T7-K2 and E71T8-K6 filler metals (with a specified toughness) generally exhibited much higher impact energies than the filler metals without a specified toughness requirement at all three temperatures, although one E70T7-K2 specimen from assembly A8 did not meet the minimum specified toughness requirement of 27 J at -29°C.

4.4 Weld Metal Chemical Analysis

The chemical composition by weight of each filler metal from both electrode manufacturers is presented in Table 4.4. All chemical elements except for Carbon and Sulphur were measured using either the Inductively Coupled Plasma or Atomic Absorption method. Carbon and sulphur were measured using a LECO Carbon and Sulphur Analyser. In all cases, the element quantities satisfy the requirements of the applicable AWS filler metal specification (AWS 1991, 1995, 1998).

4.5 Hardness Measurements

Hardness measurements were performed on both the all-weld-metal tension coupons and the transverse fillet welds to determine whether a relationship exists between weld hardness and fillet weld strength and whether the hardness of the weld coupon differs greatly from that of the associated fillet weld. Fillet weld hardness tests were conducted both before and after testing of the transverse lap splice for comparison. Measurements were taken at up to 24 locations on each fillet weld specimen, depending, in part, on the available area. The Rockwell C scale was initially used to perform the measurements for each case so that the various results could be compared directly; however, because the accuracy of the Rockwell C scale diminishes below a value of 20, a series of measurements using the Rockwell B scale was also performed. The mean

hardness measurements on the all-weld-metal coupons and on the lapped splice test specimens are presented in Tables 4.5 and 4.6, respectively. The detailed results and graphs that show the relationship between hardness and strength are presented in Appendix G.

As can be seen from Tables 4.5 and 4.6, the Rockwell B values did not vary greatly among the different filler metals. The Rockwell C values showed more variation and the differences between the all-weld-metal coupons and the fillet welds were more pronounced. The differences between the fillet weld hardness measurements before and after testing of the lapped splice specimens were relatively small.

Although the Rockwell B scale hardness measurements on all-weld-metal coupons do not show good correlation between hardness and tensile strength, it was found that the Rockwell C scale hardness measurements on the all-weld-metal coupons are linearly related to the tensile strength of the all-weld-metal coupons, as shown in Figure G2 in Appendix G. However, no correlation was found between fillet weld hardness (both Rockwell B and C scale) measurements and fillet weld strength, whether the hardness was taken before or after weld fracture, as shown in Figures G3 to G5. Furthermore, no direct relationship was found between the hardness of the all-weld-metal tension coupons and that of the associated fillet welds, as shown in Figures G6 and G7.

4.6 Transverse Fillet Weld Tests

The mean values of the transverse fillet weld test results for the three specimens cut from each assembly are presented in Table 4.7. The lapped splice and cruciform assemblies are designated in the table with a “T” and a “C,” respectively. In each case, only the weld that fractured first is considered in the values shown for stress, strain, and the fracture angle. The detailed results are presented in Appendix E, and stress vs. strain response curves are presented in Appendix F.

Test/predicted ratios for both the Canadian (CSA-S16) and American (AISC) standards are reported in Table 4.7. For each case, predicted strength is determined using both the nominal and the measured tensile strength of the weld material. Consideration

of the two ratios permits an assessment of the effect of the overstrength of the electrodes, which was found in this research project to be relatively high.

For the stress computations, the total ultimate load shown in Table 4.7 was assumed to be shared equally by the two test welds. The ultimate strengths of the fillet welds have been normalized by two methods. In method A, wherein the stress is denoted by P/A_{throat} , the ultimate strengths were calculated by dividing one-half of the ultimate load by the theoretical throat area based on the mean measured leg dimensions and weld length. In method B, wherein the stress is denoted by $P/A_{fracture}$, the ultimate strengths were calculated by dividing one-half of the ultimate load by the measured fracture surface area, which includes the weld reinforcement and root penetration. (It should be noted that neither method A nor method B gives strictly a tensile or a shear stress, but rather gives a combination of the two.) Both normalization methods have advantages and disadvantages. Method A gives the stress on the weld throat perpendicular to the theoretical face, but ignores the weld face reinforcement and the root penetration. From visual examinations of the etched sections, actual throat thicknesses of most of the fillet welds were measurably larger than the theoretical throat thicknesses. Observations also showed that in most cases, fracture planes did not lie on the shortest weld throat; therefore, the strength normalized by method A is not necessarily representative of the location in the weld where fracture occurs. Nevertheless, use of the theoretical throat is consistent with the way in which fillet welds are designed. Method B gives a true ultimate strength in that it accounts for the entire fracture surface area; however, fracture angles vary widely from 0° to 90° . As a result, the strengths given by method B are different combinations of shear and tensile stresses, depending on the fracture angle. In the extreme cases, the stresses are either pure shear or pure tension. Attempting to resolve the stresses into tensile and shear components would be misleading since the fracture surfaces are, in general, very irregular. Therefore, when comparing strengths among specimens using method B, no one-to-one comparison can be made. Using both normalization methods can give a more general interpretation of the results.

The mean values of non-dimensional deformation quantities at ultimate load and at fracture are also presented in Table 4.7. These quantities were calculated by dividing

the measured deformation by the original gauge length (equivalent to the dimension of the leg loaded predominantly in shear), then averaging the quantities for the two LVDT locations on the same test weld.

In general, weld fractures did not occur on well-defined planes, as shown in Figure 4.1. This phenomenon was also observed by Miazga and Kennedy (1989). Therefore, average values of the failure angle (measured from the shear leg) are presented in Table 4.7.

Table 4.1 – Mean Weld Metal Tension Coupon Test Results

Assembly Designation	No. of Specimens	Filler Metal Classification	Electrode Manufacturer	Steel Fabricator	Mean Static Yield Strength (MPa)	Mean Static Tensile Strength (MPa)	Mean Modulus of Elasticity (MPa)	Mean Elongation (%)
A1	2	E7014	L	W	452	520	210 700	21.7
A2	5	E70T-4	H	W	354	535 *	185 500	23.2 *
A3	2	E70T-4	H	S	472	631	198 600	22.3
A4	2	E70T-4	L	W	407	562	203 400	27.8
A5	2	E70T-7	H	W	468	605	200 800	23.1
A6	2	E70T-7	L	W	445	584 *	205 200	24.7 *
A7	2	E70T-7	L	S	483	652 *	229 400	22.9 *
A8	2	E70T7-K2	L	W	527	592	207 100	24.6
A9	2	E71T8-K6	H	W	414	490	199 900	27.6
A10	2	E71T8-K6	H	S	402	493	207 400	28.4

* Excludes one coupon that fractured prior to reaching the ultimate stress

Table 4.2 – Mean Base Metal Tension Coupon Test Results

Nominal Plate Thickness (mm)	No. of Specimens	Mean Static Yield Strength (MPa)	Mean Static Tensile Strength (MPa)	Mean Modulus of Elasticity (MPa)	Mean Elongation (%)
9.5	2	418	551	207 500	30.5
15.9	2	347	466	201 400	38.2
19.1	2	392	527	195 400	40.5
25.4	2	386	538	201 600	40.9

Table 4.3 - Charpy V-notch Impact Test Results

Assembly Designation	Filler Metal Classification	Electrode Manufacturer	Steel Fabricator	-29°C			21°C			100°C		
				Energy (J)	Energy (J)	Mean (J)	Energy (J)	Energy (J)	Mean (J)	Energy (J)	Energy (J)	Mean (J)
A1	E7014	L	W	18	23	20	58	79	68	81	77	79
A2	E70T-4	H	W	7	7	7	8	8	8	31	27	29
A3	E70T-4	H	S	9	8	9	15	18	16	57	47	52
A4	E70T-4	L	W	5	5	5	19	15	17	72	76	74
A5	E70T-7	H	W	7	5	6	16	15	16	49	56	52
A6	E70T-7	L	W	11	5	8	24	30	27	62	75	68
A7	E70T-7	L	S	7	7	7	19	20	20	43	49	46
A8	E70T7-K2	L	W	34	14	24	75	89	82	165	180	173
A9	E71T8-K6	H	W	145	140	142	186	186	186	201	214	207
A10	E71T8-K6	H	S	57	34	45	178	220	199	218	205	212

Table 4.4 – Weld Metal Chemical Analysis

Filler Metal Classification	Electrode Manufacturer	Weight (%)										
		C	Mn	Si	P	S	Ni	Cr	Mo	V	Cu	Al
E7014	L	0.092	0.260	0.369	0.015	0.0130	0.070	0.055	0.069	0.0200	0.039	<0.010
E70T-4	H	0.345	0.295	0.057	0.010	0.0036	0.024	<0.030	<0.050	0.0034	0.016	1.350
E70T-4	L	0.272	0.330	0.258	0.009	0.0041	0.012	<0.030	<0.050	0.0026	0.016	1.170
E70T-7	H	0.313	0.379	0.065	0.009	0.0032	0.017	0.034	<0.050	0.0046	0.019	1.110
E70T-7	L	0.290	0.442	0.093	0.008	0.0037	0.019	<0.030	<0.050	0.0039	0.021	1.140
E71T8-K6	H	0.106	0.806	0.088	0.015	0.0043	0.442	0.030	<0.050	0.0052	0.019	0.392
E70T7-K2	L	0.087	1.180	0.105	0.012	0.0031	1.190	0.042	0.061	0.0044	0.016	0.738

Table 4.5 – Mean Hardness of All-Weld-Metal Coupons

Filler Metal Classification	Electrode Manufacturer	Steel Fabricator	Rockwell B Hardness	Rockwell C Hardness
E7014	L	W	60	3
E70T-4	H	W	56	3
	H	S	64	15
	L	W	61	9
E70T-7	H	W	62	11
	L	S	62	14
E70T7-K2	L	W	65	12
	L	W	—	10
E71T8-K6	H	W	59	4
	H	S	56	3

Table 4.6 – Mean Hardness of Lapped Splice Specimens

Specimen Designation	Weld Size (mm)	Filler Metal Classification	Electrode Manufacturer	Steel Fabricator	Rockwell B Hardness	Rockwell C Hardness	
					After Test	Before Test	After Test
T2-1	6.4	E7014	L	W	62	—	13
T5-3		E70T-4	H	W	—	38	38
T7-1			H	S	—	39	38
T8-2			L	W	—	26	19
T9-1			L	S	—	20	26
T11-1			H	W	—	—	27
T12-2		E70T-7	H	S	—	30	32
T13-3			L	W	—	28	30
T14-1			L	S	—	25	29
T16-1			E70T7-K2	L	W	70	—
T17-1		L		S	—	29	26
T18-1		E71T8-K6	H	W	68	—	23
T19-1			H	S	68	14	18
T19-2			H	S	68	18	20
T20-2		12.7	E7014	L	W	64	—
T21-2	E70T-4		H	W	65	—	14
T22-1			H	S	69	—	22
T23-2			L	W	65	—	16
T24-2			L	S	68	—	21
T26-2	E70T-7		H	S	68	—	19
T27-3			L	W	—	—	18
T28-2			L	S	69	—	22
T31-2	E71T8-K6		H	W	64	—	15
T32-1			H	S	65	—	15

Table 4.7 – Mean Transverse Fillet Weld Test Results

Assembly Designation	Weld Size (mm)	Filler Metal Classification	Electrode Manufacturer	Steel Fabricator	Mean Ultimate Load (kN)	Test/Predicted (S16) Ratio		Test/Predicted (AISC) Ratio		Mean Ultimate P/A _{throat} (MPa)	Mean Ultimate P/A _{fracture} (MPa)	Mean Δ/D (Ultimate Load)	Mean Δ/D (Fracture)	Mean Fracture Angle (°)	
						Nominal Weld Strength	Measured Weld Strength	Nominal Weld Strength	Measured Weld Strength						
T1	6.4	E7014	L	W	510	1.54	1.42	1.72	1.59	738	665	0.09	0.10	10	
T2			L	W	473	1.49	1.38	1.67	1.54	721	706	0.10	0.10	11	
T3			L	W	520	1.38	1.27	1.54	1.42	666	729	0.09	0.09	15	
T4		E70T-4	H	W	642	2.02	1.71	2.26	1.91	976	483	0.08	0.08	0	
T5			H	W	636	2.03	1.72	2.26	1.92	978	457	0.09	0.09	0	
T6			H	W	707	2.36	2.00	2.64	2.23	1140	846	0.16	0.16	86	
T7 *			H	S	635	2.40	2.03	2.68	2.27	1122	714	0.08	0.08	90	
T8			L	W	698	1.94	1.65	2.16	1.85	932	613	0.21	0.23	9	
T9			L	S	815	2.28	1.94	2.54	2.17	1098	830	0.19	0.19	31	
T10			L	S	764	2.05	1.75	2.29	1.96	1012	747	0.11	0.12	21	
T11		E70T-7	H	W	677	1.93	1.53	2.15	1.71	930	492	0.10	0.11	0	
T12			H	S	699	2.33	1.85	2.60	2.06	1021	808	0.13	0.13	79	
T13			L	W	606	2.04	1.59	2.28	1.77	964	697	0.05	0.13	70	
T14			L	S	752	1.93	1.50	2.15	1.67	930	521	0.10	0.10	6	
T15			L	S	769	2.10	1.63	2.35	1.82	1015	528	0.06	0.06	0	
T16	E70T7-K2	L	W	714	2.00	1.62	2.24	1.81	944	693	0.27	0.29	19		
T17		L	S	738	2.46	1.99	2.75	2.23	1187	1115	0.09	0.09	82		
T18	E71T8-K6	H	W	707	2.36	2.30	2.63	2.57	1137	518	0.34	0.35	0		
T19		H	S	769	2.12	2.07	2.37	2.31	1023	787	0.19	0.19	25		
T20	12.7	E7014	L	W	870	1.25	1.15	1.39	1.29	602	477	0.15	0.16	14	
T21		E70T-4	H	W	966	1.47	1.24	1.64	1.39	708	443	0.13	0.15	0	
T22			H	S	936	1.76	1.49	1.96	1.66	849	488	0.13	0.15	0	
T23			L	W	935	1.41	1.21	1.58	1.35	682	511	0.16	0.18	14	
T24			L	S	1010	1.65	1.41	1.85	1.58	798	666	0.19	0.20	21	
T25		E70T-7	H	W	1020	1.63	1.29	1.82	1.44	783	479	0.12	0.13	6	
T26			H	S	1063	1.70	1.35	1.90	1.51	822	666	0.20	0.20	23	
T27			L	W	910	1.47	1.14	1.64	1.28	710	626	0.10	0.10	17	
T28			L	S	993	1.63	1.27	1.83	1.42	788	494	0.12	0.12	6	
T29		E70T7-K2	L	W	1069	Plate failed prior to weld fracture									
T30			L	S	1064	1.79	1.45	2.00	1.62	886	703	0.22	0.22	20	
T31		E71T8-K6	H	W	1018	1.75	1.71	1.96	1.91	846	469	0.24	0.26	0	
T32			H	S	1038	1.66	1.62	1.85	1.81	799	634	0.27	0.26	19	
C1		6.4	E70T-4	H	W	643	1.95	1.67	2.18	1.86	560	574	0.03	0.03	5
C2			E70T7-K2	L	W	641	1.92	1.56	2.14	1.74	446	720	0.03	0.03	5

* Specimens tested at -50

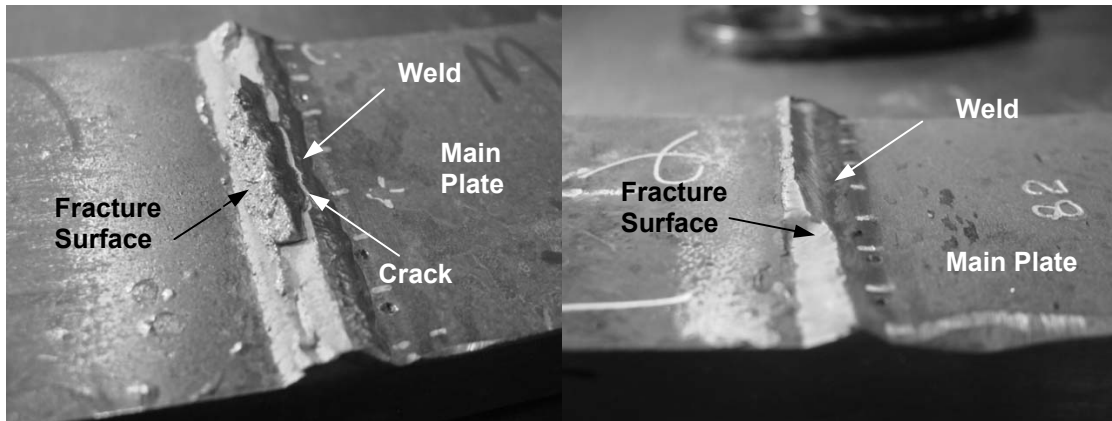

Figure 4.1 – Non-uniform Failure Surface

5. ANALYSIS AND DISCUSSION

5.1 Comparison with Miazga and Kennedy (1989)

A total of 12 test specimens (nine 6.4 mm and three 12.7 mm specimens) were prepared using E7014 filler metal and the SMAW process to provide a means of comparing the test results from this study with those of Miazga and Kennedy (1989) who tested three 5 mm and three 9 mm specimens using the same filler metal and process.

Table 5.1 presents the welding parameters and material properties of specimens tested by Miazga and Kennedy (1989) and those produced using E7014 filler metal in this research program and Table 5.2 presents a summary of specimen dimensions and test results. Figure 5.1 shows a graphical comparison of the test results from Miazga and Kennedy and the present research. As seen in Table 5.1, the all-weld-metal tension coupon results from the two studies are similar. Although Miazga and Kennedy (1989) did not report the welding parameters for the all-weld-metal tension coupons, it can be expected that the difference in material properties is small because the plate thickness is standardized and preparation of the groove weld follows stringent rules with respect to interpass temperature, ensuring a relatively consistent cooling rate among specimens. By contrast, this level of control is not maintained for the fillet welds.

Both the welding speed and the current used for producing the fillet welds are reported in Table 5.1 and it can be seen that they are somewhat different for the two investigations. Furthermore, Miazga and Kennedy (1989) modified their welding parameters for the two weld sizes tested, whereas the same parameters were used in this research program throughout. Since heat input is inversely proportional to welding speed and directly proportional to current, an estimate of heat input can be made for each case. In addition to heat input, another factor that affects weld strength is the effect of tempering in multi-pass welds where subsequent weld passes temper the previously deposited passes. A comparison of the 9 mm weld specimens from Miazga and Kennedy (1989) with the 12.7 mm specimens from this study, which were both specimens prepared with three weld passes, indicates that the heat input for the 9 mm welds was only slightly lower (about 10%, assuming equal arc voltage) than the heat input used for

the 12.7 mm specimens. This should result in similar strengths in both weld sizes as observed in Figure 5.1. A comparison of the 6.4 mm weld from this program with the 9 mm weld from the Miazga and Kennedy (1989) test program shows again a lower heat input in the Miazga and Kennedy test program than in this program. However, the multi-pass 9 mm weld would be expected to have a lower strength than the single pass 6.4 mm weld due to the tempering taking place in the multi-pass process. This is also observed in Figure 5.1. However, an anomaly is observed with the 5 mm welds from Miazga and Kennedy. A comparison the 5 mm and the 9 mm welds from Miazga and Kennedy indicates that the heat input in the 9 mm welds was about 20% higher than that in the 5 mm weld, which should result in a lower strength for the 9 mm welds. In addition, the 5 mm welds were deposited in a single pass whereas the 9 mm welds were deposited in three passes. This should cause a further decrease in strength of the 9 mm welds compared to the 5 mm welds. An examination of Figure 5.1 indicates, however, that the 9 mm welds are stronger than the 5 mm welds. This anomaly cannot be explained by any of the welding parameters reported by Miazga and Kennedy (1989). The significantly smaller scatter in test results of Miazga and Kennedy compared to the present research is likely due to the fact that their specimens were fabricated by a welder working primarily in research in a university laboratory.

Another parameter that may affect the strength of the fillet welds is whether or not the base material has yielded prior to rupturing of the weld. The plates used with all of the 6.4 mm specimens in the present research remained elastic throughout the tension test, as did the plates used with all specimens in the work of Miazga and Kennedy (1989). However, the base plates of the 12.7 mm specimens in the present research yielded before weld fracture. Because no direct comparison (that circumvents the effect of weld size) is available to assess the specific effect of plate yielding, the influence on weld strength of the restraint gained from the base plates remaining elastic could not be determined with confidence. There is a need to investigate the effect of yielding of the base plates in future studies.

Figure 5.2 shows a graphical comparison of the ductility of the test specimens from Miazga and Kennedy (1989) and the present research. Since Miazga and Kennedy reported only the mean leg dimension of the two test welds on the same specimen and all

four deformations at fracture captured by the four LVDTs (two on each test weld), the strain quantities reported herein are calculated by averaging the LVDT readings and dividing by the associated mean leg dimension. For comparison, the data from the present research reported in Table 5.2 for strain at fracture is calculated by averaging the four deformations at the four LVDT locations then dividing by the mean shear leg dimension of the two test welds. It should be noted that in this section only, strains for the specimens in this research program are calculated using the leg dimension instead of the gauge length for consistency with the method of Miazga and Kennedy, although the difference is slight. Since the majority of specimens in the E7014 series had base plates that remained elastic, this method likely gives a somewhat better estimate of strains in the weld when they become large (*e.g.*, the fracture strain) in comparison to the concurrent strains in the base plate.

The two sizes of fillet weld from Miazga and Kennedy (1989) exhibited similar levels of strain at fracture. On the other hand, in the present research, the larger size of fillet weld exhibited higher fracture strains than the smaller size, as was also observed in the specimens made with the other filler metals. The two sizes of fillet weld in the present research exhibited higher fracture strains than the similar sizes of fillet weld in Miazga and Kennedy (1989), although the all-weld-metal tension coupon results show that Miazga and Kennedy's specimens exhibited a slightly higher ductility than those in the present research. Therefore, it is found that when heat input is constant, a larger weld size results in higher ductility.

Although there are some modest differences in the results of Miazga and Kennedy (1989) as compared to those of the E7014 specimens tested in the present research program, except for the 5 mm welds from Miazga and Kennedy, which show some apparent anomaly, these can be explained by factors such as the differences in the welding parameters used. It is concluded that the new research is substantially consistent with the methods of Miazga and Kennedy and that meaningful comparisons can be made with the results for the FCAW specimens presented herein.

5.2 Effect of Variables on Fillet Weld Behaviour

5.2.1 General

The test results were analyzed to determine the influences of each variable on the behaviour of fillet welds. In every case, only one variable was considered, with all other parameters kept constant. The results of the analysis are shown in Figures 5.3 through 5.8. In the figures, both the mean values, indicated by a solid dot, and the full range of test results are presented. For the reasons discussed in section 4.6, stresses normalized by both the theoretical throat area and the fracture surface area are used for the comparisons. As expected, in general the stresses normalized by the theoretical throat area are higher than those normalized by the fracture surface area primarily because the former neglects weld root penetration and face reinforcement. For determining the influence of each variable on fillet weld ductility, strain at fracture for each case is compared. The parameters considered in this analysis were:

- 1) Filler Metal – Five different weld electrode classifications were incorporated in this test program, two with a toughness requirement and three without. A total of 72 lapped splice specimens were fabricated with electrodes without a toughness requirement and 24 were fabricated with electrodes with a toughness requirement.
- 2) Electrode manufacturer – Electrodes were supplied by two manufacturers, namely, Lincoln and Hobart. A total of 54 specimens were prepared with electrodes from Lincoln and 42 from filler metal by Hobart.
- 3) Steel fabricator – The specimens were fabricated by Supreme and Waiward. Supreme fabricated 42 test specimens and Waiward fabricated 54.
- 4) Weld size – Two weld sizes were tested, namely, 6.4 mm and 12.7 mm. A total of 57 specimens were fabricated using 6.4 mm welds and 39 were fabricated with 12.7 mm welds.
- 5) Root Notch Orientation – Two root notch orientations were considered in the research. A total of 96 specimens were manufactured as lapped splices, while six were fabricated in a cruciform configuration for comparison.
- 6) Test temperature – All the specimens were tested at room temperature except for three lapped splice E70T-4 specimens that were tested at -50°C .

Although not intended to be a primary variable in the research, the effect of the unequal leg sizes is also discussed. The differences in leg size arose from the fact that the specimens were all welded in the horizontal position. The magnitude of the differences varied considerably among the specimens.

Due to the unique nature of the tests on cruciform sections and on lapped splice specimens tested at -50°C (items 5 and 6 above), and the fact that these were manufactured in small numbers without varying all of the other parameters (items 1 to 4), these specimens are not included in the comparisons that follow except where they are being specifically investigated. That is, the cruciform specimens and the -50°C specimens are excluded from Figures 5.3 through 5.6. Other cases where tests have been excluded in the comparisons are described in the sections that follow.

5.2.2 Filler Metal Classification and Toughness

Charpy impact test results show that the toughness of the E7014 filler metal (SMAW) was about three times higher at -29°C and 21°C than the FCAW filler metals without a specified toughness; however, the all-weld-metal tension coupons had similar strength to many of the FCAW filler metals. The FCAW filler metals with a specified toughness had Charpy impact energies up to about 15 times higher than those without a specified toughness. These differences in toughness provide an indication of the effect of toughness—as well as the other properties of the electrodes—on strength and ductility. The comparison among the different electrode classifications tested, as well as the grouped classifications with and without a toughness requirement, is presented graphically in Figure 5.3.

Lapped splice test results normalized using the theoretical throat area show that specimens made with E7014 filler metal had the lowest mean strength among all filler metals. It should be noted that for all these SMAW specimens, the fracture surface areas are similar to the theoretical throat areas. On the other hand, for the majority of FCAW specimens, the fracture surface areas are in the order of about 1.5 to 2 times larger than the theoretical throat areas. This could be because of the relatively higher penetration of FCAW filler metal. For comparison, Figure 5.9 shows the typical fracture surfaces of an E7014 and an E70T-4 specimen. Therefore, comparing fillet welds made with SMAW to FCAW filler metals based on results normalized using the fracture surface area accounts for the significant difference in penetration. Test results normalized using the fracture surface area show no clear distinction in mean strengths among filler metals without a

specified toughness. The results normalized using both methods show that fillet welds made with filler metals with a specified toughness provide the highest mean strength among all types of filler metal (normalized using the fracture surface area, the ratio of the mean strength of specimens made with filler metals with a specified toughness to that of those without a specified toughness is about 1.15), although in the all-weld-metal tension coupon test results they did not show the highest mean strength. It can be concluded that the welding process (SMAW or FCAW) has no significant effect on fillet weld strength, but fillet welds made with filler metals with a specified toughness tend to possess a somewhat higher strength than those made with filler metals without. The fillet welds made with filler metals having a specified toughness also showed more variability in strength. The variability can be because of the lack of experience of welders working with these types of filler metal. It was reported from welders that some difficulties were experienced in fabrication.

The all-weld-metal tension coupon and lapped splice test results show that the specimens made with filler metals with a specified toughness had the highest ductility—as defined by the mean failure strain—among all types of filler metal considered, although in individual cases somewhat lower ductility was also observed. The ratio of the mean fracture strain of specimens made with filler metals with a specified toughness to that of those without is about 1.81. Fillet welds made with filler metals with a specified toughness also showed significantly higher variability. Of the electrodes without a specified toughness, no obvious distinction in ductility was found between fillet welds made with E7014 and E70T-7 filler metals. However, the mean fracture strain of fillet welds made with E70T-4 filler metal was somewhat higher, with ratios of E70T-4 fracture strains to those for the E7014 and E70T-7 filler metals of about 1.33 and 1.30, respectively. It can be concluded that the toughness of a filler metal has a significant influence on fillet weld ductility.

5.2.3 Electrode Manufacturer

In this comparison, results of fillet welds made with E7014 filler metal were not included because E7014 filler metal from only one electrode manufacturer, Lincoln, was used in the study. All-weld-metal tension coupon results show that specimens made with

filler metals manufactured by the two electrode manufacturers provided a similar level of mean strength. Despite significant variability, the mean strengths of coupons made with filler metal without a specified toughness—both yield and ultimate—between electrode manufacturers is within 5%. The ratios of the mean yield and ultimate strengths of the Lincoln E70T7-K2 coupons to those of the Hobart E71T8-K6 coupons are about 1.29 and 1.20, respectively. A comparison of the effects of the electrode manufacturer on fillet weld behaviour is presented graphically in Figure 5.4. Results of lapped splice specimens normalized using the theoretical throat area show that fillet welds made with filler metals produced by the two electrode manufacturers exhibited similar strength, but results normalized by the other method show that the ratio of the mean strength of fillet welds made with Lincoln filler metals to that of those made with Hobart filler metals is about 1.14. However, the strength range of the Hobart specimens shows less variability and is overlapped entirely by the Lincoln specimens, indicating that it is unlikely that any difference in strength should be considered significant. It should be noted that different welding parameters were used by the two fabricators to produce test specimens for the same classification and source of filler metal (see Appendix A for details). This can explain, in part, the variation observed between manufacturers.

Lapped splice test results show that the ratio of the mean fracture strain of specimens made with Lincoln filler metal to that of those made with Hobart filler metal is about 0.87, as shown in Figure 5.4c, although all-weld-metal tension coupon results show that the mean ductility of coupons made with filler metal manufactured by both manufacturers were very similar. Nevertheless, the two ductility ranges observed were large and there is significant overlap.

5.2.4 Steel Fabricator

In this comparison, results of fillet welds made with E7014 filler metal are not included because these specimens were produced by only one steel fabricator, Waiward. The results for the lapped splice specimens are summarized graphically in Figure 5.5. From the normalization using the theoretical throat area, the ratio of the mean strength of Waiward specimens to that of Supreme specimens is about 0.92. From the other normalization (Figure 5.5b), the ratio of the mean strength of the Waiward specimens to

that of the Supreme specimens is about 0.79. It can be concluded that there can be significant variability in weld strengths among fabricators, although it should be stressed that this is likely greatly influenced simply by the welding parameters selected.

A comparison of fillet weld ductility is presented graphically in Figure 5.5c. The ratio of the mean ductility of the Waiward specimens to that of the Supreme specimens is about 1.21. It can be concluded that significant variability in ductilities can be expected among welds produced by different fabricators.

5.2.5 Weld Size

As mentioned in many previous studies, fillet weld capacity is not linearly proportional to weld size, and smaller fillet welds generally exhibit a higher unit strength than larger fillet welds. A comparison of the two sizes tested in this research is presented graphically in Figure 5.6. Test results normalized by the theoretical throat area and by the fracture surface area show that the ratios of the mean strengths of 6.4 mm fillet welds to that of 12.7 mm fillet welds are 1.26 and 1.24, respectively. From both normalizations, the strength ranges of 12.7 mm fillet welds were at the lower end of the strength ranges of 6.4 mm fillet welds, and less variability was observed for the 12.7 mm welds. It can be concluded that the smaller weld size provides significantly higher strength, confirming that fillet weld capacity is not linearly proportional to weld size.

The ratio of the mean ductility of the 6.4 mm specimens to that of the 12.7 mm specimens is about 0.80. It can be concluded based on this study that larger welds provide somewhat higher weld ductility and less variability was also observed.

5.2.6 Root Notch Orientation

In this comparison, only results of 6.4 mm fillet welds made with E70T-4 and E70T7-K2 filler metal are included because all cruciform specimens were prepared using these two types of filler metals and this leg size. A comparison is presented graphically in Figure 5.7. From normalization using the theoretical throat area, fillet welds in a weldment having a cruciform configuration provide similar strengths to those in a lapped splice configuration. The ratio of the mean strength of lapped splice specimens to that of cruciform specimens is about 1.06. From normalization using the fracture surface area,

the ratio of the mean strength of lapped splice specimens to that of cruciform specimens is about 1.13. It can be concluded that the more severe root notch orientation present in cruciform sections may result in slightly lower weld capacity. Further tests are required to confirm this observation.

The mean ductility of lapped splice specimens is about 3.8 times that of cruciform specimens. It can be concluded that fillet weld ductility is significantly affected by the root notch orientation, and fillet welds in a cruciform configuration provide significantly lower ductility. Because of the relatively small number of cruciform specimens tested, more research is required on this effect.

5.2.7 Low Temperature

In this comparison, only E70T-4 specimens with 6.4 mm legs were included because only specimens of this type were tested at $-50^{\circ}C$. The comparison is presented graphically in Figure 5.8. The specimens tested at $-50^{\circ}C$ showed a higher mean strength than those tested at room temperature. From normalization using the theoretical throat and the fracture surface area, respectively, the ratios of the mean strength of specimens tested at $-50^{\circ}C$ to that of specimens tested at room temperature are about 1.13 and 1.09. It can be concluded that low temperature does not appear to have a negative effect on fillet weld strength, although more tests are required to confirm this observation.

As shown in Figure 5.8c, the ductility of specimens tested at $-50^{\circ}C$ was lower than the equivalent specimens tested at room temperature and the variability was quite low. The ratio of the mean fracture strain of specimens tested at $-50^{\circ}C$ to that of the equivalent specimens tested at room temperature is about 0.58. The ductility of these specimens tended toward the lower end of the observed range of all fillet welds tested. It can be concluded that, as expected, low temperature significantly lowers the ductility of fillet welds.

5.2.8 Unequal Leg Dimension

Although the specimens were designed to have equal legs, the sizes of the shear leg and the tension leg of the same weld were rarely found to be equal in this study. Some specimens had significantly different leg dimensions and usually the shear leg was larger than the tension leg, which can be attributed to the fact that the specimens were welded in the horizontal position. Test results show that fracture angles were influenced by the ratio of shear/tension leg dimensions, in turn having an effect on the weld strength. In general, when the dimensions of the shear leg and tension leg are about equal, the fracture angle is close to 0° . Welds that failed at an angle close to 90° had a tension leg that was significantly smaller than the shear leg. Figure 5.10 shows the weld and lap plates from a specimen that fractured at an angle of 0° and another specimen (main plate) with the weld fractured at an angle close to 90° . The resulting fracture angles are found not to be in agreement with the theoretical prediction proposed by Kamtekar (1982).

5.2.9 Summary of Effect of Variables on Fillet Weld Behaviour

Toughness of the filler metal, electrode manufacturer, steel fabricator, and weld size all seem to influence fillet weld strength to some degree. Although electrode manufacturer and steel fabricator were found to have some influence on fillet weld strength, these parameters cannot reasonably be incorporated into design equations. Furthermore, the fabricators reported some difficulty welding with certain electrodes—depending on whether or not their welder had experience with that or a similar electrode—so there is likely a statistical interaction between the effects of electrode manufacturer and steel fabricator and the electrode classification. (It must also be stressed that differences between fabricators are likely partially attributable to factors such as the welding parameters selected.) The root notch orientation was shown to have some effect on weld strength in that the cruciform configuration gave rise to slightly lower strength welds than did the equivalent lapped splice specimens. However, more research is required to evaluate this effect conclusively. Testing specimens at $-50^\circ C$ resulted in somewhat higher strength than testing at room temperature. Again, few specimens were tested at $-50^\circ C$, but it can be concluded that low service temperatures likely have no detrimental effect on weld strength. For these reasons, filler metal

classification (with or without toughness) and fillet size are considered to be the parameters that are most influential to weld strength.

Of the parameters investigated, toughness of the filler metal, weld size, root notch orientation, and test temperature were found to have the most influence on fillet weld ductility. Furthermore, it was found that with the exception of the comparisons of electrode classification and root notch orientation, where the strength was found to be higher, ductility was generally lower. The tough electrodes studied, in general, provided both higher strength and ductility than those with low toughness, as did the lapped splice specimens as compared with the cruciforms. To provide a frame of reference, it is instructive to compare the ductilities observed in this research program with a common benchmark from the literature. As such, Figure 5.11 shows a comparison of the strains of all test specimens with predicted values from the empirical equations presented by Lesik and Kennedy (1990). These equations predict strains at the ultimate load and at fracture of 0.049 and 0.056, respectively, which are shown as dashed lines in the figure. The great majority of specimens tested in this research exceeded these predictions. Only the cruciform specimens fell consistently below the predicted values.

The unequal leg dimensions that arose simply as a result of the horizontal welding position also had an effect on the fillet weld behaviour. Fillet welds with approximately equal leg sizes tended to fail with a 0° fracture angle, but when the tension leg was significantly smaller than the shear leg, the weld tended to fail at close to 90° .

5.3 Fracture Surface Examination

The fracture mode of welds that ruptured on the shear plane (with a 0° fracture angle), on the tension plane (with a 90° fracture angle), and at intermediate fracture angles was determined by examining the fracture surfaces of some representative test specimens under a scanning electron microscope. In test specimens that fractured at or close to 0° , the fracture surfaces show elongated microvoids. This indicates a ductile shear fracture. Figure 5.12a shows a typical shear fracture surface in the weld metal from specimen T2-3 (E7014(L)W 6.4 mm), where the fracture angle was 9° . In test specimens that fractured at or close to 90° , the fracture surfaces show various combinations of

equiaxed (rounded) microvoids and cleavage. This is evidence of a tension fracture. Figure 5.12b shows a typical tension fracture surface in the weld metal from specimen T13-1 (E70T-7(L)W 6.4 mm), where the fracture angle was 90°. Several test specimens had fracture angles close to 20°. The fracture surfaces for these specimens were typically ductile. Figure 5.12c shows a typical fracture surface in the weld metal from specimen T32-2 (E71T8-K6(H)S 12.7 mm), where the fracture angle was 23°. Some fracture surfaces showed some areas of microvoid coalescence and some areas of cleavage fracture, including all specimens tested at low temperature. Appendix H presents a detailed series of fracture surface photomicrographs.

5.4 Comparison with Current Design Equations

Test results were compared with the equations in the current North American design standards. The equation in Canadian standard CSA-S16 (CSA 2001) was presented previously (Equation 2.6) and the AISC Specification (AISC 1999) takes a similar form:

$$V_r = 0.60 \phi A_w F_{EXX} (1.0 + 0.50 \sin^{1.5} \theta) \quad [5.1]$$

where ϕ is the resistance factor, A_w is the theoretical throat area, F_{EXX} is the minimum specified tensile strength of the filler metal (same definition as X_u in CSA-S16), and θ is the angle of loading with respect to the weld axis. Note that the two design standards differ only in the leading coefficient (0.67 vs. 0.60) and the value of the resistance factor. The results were compared with the standards in two ways. In method 1, fillet weld capacities were predicted using weld metal nominal strength, 480 MPa in all cases, and in method 2, they are determined using the measured strength from the all-weld-metal tension coupon tests with the identical parameters. Table 4.7 shows the mean test/predicted ratios for the two design standards using both methods. In the table, ϕ is taken as 1.0, and A_w is taken as the theoretical throat area (calculated from the measured leg dimensions, but neglecting the root penetration and weld reinforcement), X_u or F_{EXX} follow the procedures of method 1 or 2, and θ is 90°. Method 1 shows the safety margin provided by the design equations by including the excess weld metal strength, while

method 2 eliminates from the test/predicted ratios the effect that can be attributed directly to overstrength of the weld material itself, which can in some cases be considerable. This distinction permits an assessment of the expected margin of safety should electrodes be used that have a tensile strength that marginally exceeds the nominal value.

The test/predicted ratios for individual specimens are presented in Appendix E. Test/predicted ratios using both methods are in all cases greater than 1.0. Figures 5.13 and 5.14 show a comparison of the test and predicted values for the two methods for CSA-S16 and AISC, respectively. The diagonal lines indicate a test/predicted value of 1.0. As shown in the figures, all test results lie on the conservative side. When the nominal filler metal tensile strength is used, the mean test/predicted ratios vary from 1.25 (1.39 for the AISC Specification) to 2.46 (2.75 for AISC). Similarly, when the measured filler metal strength is used, the mean test/predicted ratios are reduced to 1.14 (1.28 for the AISC Specification) to 2.30 (2.57 for AISC). Of all filler metals considered, the E7014 filler metal tended to provide capacities closest to the predicted values. E70T-4 and E70T-7 filler metals tended to provide similar test/predicted ratios, and generally higher than the E7014 specimens. Filler metals with a specified toughness (E70T7-K2/E71T8-K6) tended to provide the highest test/predicted ratios. For CSA-S16, the mean test/predicted ratios for the E7014, E70T-4, E70T-7, E70T7-K2, and E71T8-K6 electrodes individually are 1.42, 1.90, 1.86, 2.17, and 1.97, respectively, using normalization method 1, and 1.31, 1.62, 1.44, 1.75, and 1.86, respectively, using method 2. For the AISC specification, the mean test/predicted ratios for the E7014, E70T-4, E70T-7, E70T7-K2, and E71T8-K6 electrodes individually are 1.59, 2.12, 2.08, 2.42, and 2.20, respectively, using normalization method 1, and 1.46, 1.80, 1.63, 1.97, and 2.15, respectively, using method 2. For CSA-S16, the ratios of the mean test/predicted ratio for the 6.4 mm fillet welds to that for the 12.4 mm fillet welds are about 1.28 and 1.27 for method 1 and 2, respectively, and for AISC specification, the ratio is 1.28 using both methods. For CSA-S16, the ratios of the mean test/predicted ratio for the lapped splice specimens to that for the cruciform specimens are about 1.07 and 1.08 for method 1 and 2, respectively, and for AISC specification, the ratios are about 1.02 and 1.01 for method 1 and 2, respectively. For CSA-S16, the ratios of the mean test/predicted ratio for the specimens tested at -50°C to that for the specimens tested at

room temperature is about 1.16 using both methods, and for AISC specification, the ratios are 1.17 and 1.16 for method 1 and 2, respectively. In determining the mean test/predicted ratios for the individual parameters, as presented above, the specimens included were the same as those used in the comparisons presented in Figures 5.3 and 5.6 to 5.8.

5.5 Evaluation of Safety Index

The safety index, β , is a common measure for quantifying the level of safety being provided in structures. It is evaluated for transverse fillet welds based on the results of this test program using the same procedure as Lesik and Kennedy (1990). The resistance factor, ϕ , can be calculated as follows (based on Galambos and Ravindra (1978)):

$$\phi = \Phi_{\beta} \rho_R \exp(-\beta \alpha_R V_R) \quad [5.2]$$

A value of 0.55 for the coefficient of separation, α_R , was also proposed by Galambos and Ravindra. Ravindra and Galambos (1978) and Fisher *et al.* (1978) suggested that the safety index, β , be taken as 4.5 for connections to ensure that the probability of failure of the connection is less than that of the member as a whole, for which a value of 3.0 is commonly used in buildings. Φ_{β} is an adjustment factor for modifying the resistance factor for cases where β is not equal 3.0, which was assumed in the analysis of the loads. An equation for Φ_{β} , proposed by Franchuk *et al.* (2002), has been used in the evaluation of safety indices that follows:

$$\Phi_{\beta} = 0.0062\beta^2 - 0.131\beta + 1.338 \quad [5.3]$$

This equation was calibrated for β in the range of 1.5 to 5.0 and was found to be in error by less than 2% for dead to live load ratios from 0.5 to 2.0. Although the β values in some cases were found to be greater than 5.0 and the error of Equation 5.3 for a particular dead to live load ratio increases with increasing values of β , the maximum error in the value of the adjustment factor presented in the following discussion for dead to live load ratios from 0.5 to 2 is about 4.3%. This translates into a maximum error in β in the

same range of dead to live load ratios of 1.4%. Modifying Equation 5.3 could reduce this error somewhat, but a certain degree of potential error is unavoidable when accounting for a broad range of dead to live load ratios. In any case, for values of β greater than 5.0, the probability of failure is very small and it is therefore considered that further refinement is unwarranted.

The value of the bias coefficient for resistance, ρ_R , representative of the expected mean-to-nominal resistance, is:

$$\rho_R = \rho_G \rho_{M1} \rho_{M2} \rho_P \quad [5.4]$$

and the associated coefficient of variation is given by:

$$V^2_R = V^2_G + V^2_{M1} + V^2_{M2} + V^2_P \quad [5.5]$$

where ρ_G is the mean value of the measured-to-nominal ratio of theoretical throat area, and V_G is the associated coefficient of variation. The two material parameters accounting for the variation of material strength are ρ_{M1} and ρ_{M2} . ρ_{M1} is the mean ratio of the measured ultimate tensile strength of weld metal to the nominal strength. ρ_{M2} represents the ability of the coefficient used in the design equation to determine the ultimate shear strength from the tensile strength and is calculated as the mean ratio of measured (failure load divided by the theoretical throat area for longitudinal fillet welds, generally considered to fail in shear on the throat) to predicted ultimate shear strength (0.67 or 0.60, for the CSA-S16 and AISC specifications, respectively, times the measured tensile strength from all-weld-metal tension coupons of the same weld material). V_{M1} and V_{M2} are the associated coefficients of variation of these two material parameters, respectively. ρ_P , the professional factor, is the mean test to predicted capacity ratio:

$$\rho_P = Mean \left(\frac{Test\ Capacity}{A_{throat} \times \tau_u \times (1.00 + 0.50 \sin^{1.5} \theta)} \right) \quad [5.6]$$

and V_P is the associated coefficient of variation. The predicted capacity values are calculated using Equation 2.6 or 5.1, with actual values used for the theoretical throat area (based on the measured leg sizes) and the ultimate shear strength (based on the

results of longitudinal fillet weld tests). The “measured” ultimate shear strength, represented in Equations 2.6 and 5.1 by $0.67 \times F_u$ or $0.60 \times F_{EXX}$, respectively, was determined from longitudinal fillet weld tests on specimens having the same electrode classifications.

Table 5.3 shows the values of the statistical parameters and the resulting safety indices for the variables considered in the research, broken down into six categories. Prior to grouping the specimens into categories, the specimens tested at $-50^\circ C$ and the cruciform specimens were removed from the data pool since they were very targeted investigations and the tests were conducted in small numbers. The “All” category includes the test/predicted ratios of all specimens (except $-50^\circ C$ and cruciform) and is intended to reflect the overall level of safety of transverse fillet welds. The remaining categories are for the 6.4 mm and 12.7 mm weld sizes individually and E7014 (SMAW), E70T-4/E70T-7 (FCAW without a specified toughness), and E70T7-K2/E71T8-K6 (FCAW with a specified toughness) filler metals. These five categories provide an indication of the relative levels of safety for the various cases of the variables found to be most influential in determining fillet weld capacity. The safety indices for specimens tested at $-50^\circ C$ and cruciform specimens were not evaluated because the available data are very limited.

The sample for determining ρ_G and V_G for all six categories includes both test welds on all specimens, including the specimens tested at $-50^\circ C$ and cruciform specimens (in total 204 samples). This parameter represents only the variability of the weld size; therefore, weldment configuration and test condition are not relevant. The values used for ρ_G and V_G lead to somewhat more conservative values of the safety index than those (1.034 and 0.026, respectively, with a smaller sample size of 42) used by Lesik and Kennedy (1990). The values of ρ_{M1} and V_{M1} are taken from Lesik and Kennedy (1990) for all categories because the sample size they used to determine this parameter is relatively large (672) as compared to the sample size determined from the all-weld-metal tension coupons tested as part of this research (20). Furthermore, the values of ρ_{M1} and V_{M1} determined from the 20 tests in this research (weighted equally)

would have been similar (1.162 and 0.093, respectively), confirming that the values taken from Lesik and Kennedy (1990) seem reasonable. (It should be noted that the effects of using the lower values of both ρ_{M1} and V_{M1} in the determination of the safety index tend to offset one another.) The values selected for the parameters ρ_{M2} and V_{M2} for the first four categories shown in Table 5.3 are based on the results of Lesik and Kennedy (1990). Beyond the large sample size (126), these results are also considered to be representative of welds produced using the SWAW process and conservative for FCAW welds. For the two categories that isolate the FCAW process, the values of ρ_{M2} were determined using the FCAW longitudinal fillet weld test data from Deng (2002). These tests were conducted as part of the second phase of this project and the welds were made using the same wire spool as the associated transverse specimens. The data of Deng (2002) are considered appropriate for these two categories in that they reflect the increased penetration often observed in FCAW welds. (These shear strengths were determined using measured weld leg dimensions, but it must be kept in mind that the stresses on the theoretical throat are artificially high since both the penetration and the face reinforcement are neglected. Therefore, higher values may actually reflect the depth of penetration, for example, more than the shear strength of the material itself.) For the E70T-4/E70T-7 category, the data for the two classifications were weighted equally. For the E70T7-K2/E71T8-K6 category, because E70T7-K2 filler metal was not tested by Deng (2002), the measured shear strength, τ_u , is estimated from the all-weld-metal tension coupon test results. The tension coupon test results show that the mean ultimate tensile strength of E70T7-K2 filler metal is 1.20 times that of E71T8-K6 filler metal. Therefore, the estimated shear strength, τ_u , for E70T7-K2 filler metal is taken as 1.20 times the mean measured shear strength of E71T8-K6 filler metal. The data for the E70T7-K2 and E71T8-K6 classifications were weighted equally. Due to the relatively small number of longitudinal weld specimens (three each for the three electrode classifications tested) of Deng (2002), the small values of the coefficient of variation determined from that data are considered to be unreliable. As an approximation of the dispersion, therefore, the value of V_{M2} from the large data set of Lesik and Kennedy (1990) was used. For determining ρ_p and V_p , τ_u in Equation 5.6 for the test specimens

made with E70T-4, E70T-7, and E71T8-K6 filler metals is taken from the longitudinal weld test data of Deng (2002). In the cases of the E7014 and E70T7-K2 filler metals, no longitudinal weld specimens were produced. For the E7014 specimens, the results of the longitudinal welds tested by Miazga and Kennedy (1989) were used. For the E70T7-K2 specimens, 1.20 times the results of longitudinal weld tests for the E71T8-K6 electrodes were used, as was done in determining the second material factor. The mean values of the ultimate shear strength, τ_u , used in determining ρ_p for the E7014, E70T-4, E70T-7, E70T7-K2, and E71T8-K6 filler metals are 411 MPa (Lesik and Kennedy 1990), 496 MPa, 545 MPa, 608 MPa, and 506 MPa, respectively.

Although the values of some intermediate parameters differ between the two standards addressed in Table 5.3, the resulting safety indices are identical. This stems from the fact that the products of the respective resistance factor and shear coefficient are the same, making the predicted factored weld capacity identical. Safety indices for all categories are at least equal to the traditional target value for connections of 4.5. The value of the safety index determined from all of the tests is 4.8, which can be considered to be representative of an array of fillet weld conditions, as described previously. As expected, the safety index for 6.4 mm fillet welds (5.7) was found to be significantly higher than that for 12.7 mm welds (4.5), with the latter being equal to the traditional target value for connections. Of the categories based on electrode classification, the lowest safety index (5.0) was determined for fillet welds made with E7014 filler metal. Fillet welds made with FCAW filler metals without a specified toughness (E70T-4/E70T-7) resulted in a safety index (5.5) higher than that of SMAW fillet welds, but significantly lower than that (6.6) of fillet welds made with filler metals with a specified toughness (E70T7-K2/E71T8-K6). It should be noted that the number of specimens with 12.7 mm fillet welds in every category is fewer than that of 6.4 mm fillet welds, as shown in Table 5.3, which may lead to somewhat higher safety indices than if the samples had included randomly selected weld sizes. To assess this potential effect quantitatively, additional tests on larger fillet welds are needed to expand the data pool.

Table 5.1 – Comparison of Welding Parameters and Material Properties

Parameter	Miazga & Kennedy		Present research	
	5 mm	9 mm	6.4 mm	12.7 mm
No. of Specimens	3	3	9	3
Welding Parameters				
Welding Speed (mm/min)	250	205	254	254
Current (A)	125	125	170	170
Filler Metal Properties				
Modulus of Elasticity (MPa)	207 600	207 600	210 700	210 700
Yield Strength (MPa)	465	465	452	452
Tensile Strength (MPa)	538	538	520	520
Fracture Strain (%)	25	25	22	22
Splice Plate Material Properties			*	
Yield Strength (MPa)	364	346	418	347
Tensile Strength (MPa)	522	513	551	466
Fracture Strain (%)	23	27	31	38
Main Plate Material Properties				
Yield Strength (MPa)	346	324	392	386
Tensile Strength (MPa)	513	493	527	538
Fracture Strain (%)	27	32	40	41

* The plates listed for 12.7 mm specimens were used in three of the nine cases.

Table 5.2 – Summary of Results of Specimens Made with E7014 Filler Metal

Specimen Designation	Miazga and Kennedy (1989)										Present Research									
	90.1	90.2	90.3	90.11	90.12	90.13	T1-1	T1-2	T1-3	T2-1	T2-2	T2-3	T3-1	T3-2	T3-3	T20-1	T20-2	T20-3		
Nominal Weld Size (mm)	5.0	5.0	5.0	9.0	9.0	9.0	6.4	6.4	6.4	6.4	6.4	6.4	6.4	6.4	6.4	12.7	12.7	12.7		
Average Leg Size (mm)	5.3	5.3	5.3	9.1	9.3	9.3	6.6	6.4	6.3	5.9	6.1	6.4	7.1	7.4	7.5	13.8	13.0	13.7		
Total Weld Length (mm)	200	200	201	197	200	200	152	152	152	152	152	152	152	152	152	152	152	152		
Test Capacity (kN)	421	431	407	789	807	791	513	502	513	462	474	482	523	518	520	782	949	878		
Fracture Strain (%)	5.9	3.8	6.7	5.8	5.2	5.5	9.3	10.0	11.0	8.4	9.5	8.3	7.5	7.8	6.7	10.6	15.5	11.9		
Fracture Angle (deg.)	10	13	10	16	21	20	12	8	9	9	14	9	15	18	12	27	7	7		
Theoretical Throat Area (mm ²)	742	754	752	1267	1309	1295	704	684	673	630	651	689	758	796	801	1479	1397	1474		
P/A _{throat} (MPa)	567	572	541	623	616	611	729	734	762	733	728	700	690	651	650	529	679	596		

Table 5.3 – Safety Indices

CSA-S16						
	All	6.4 mm	12.7mm	E7014	E70T-4/E70T-7	E70T7-K2/E71T8-K6
Sample Size	86	52	34	12	54	19
No. 6.4 mm	52	52	0	9	31	11
No. 12.7 mm	34	0	34	3	23	8
ρ_G	0.998	0.998	0.998	0.998	0.998	0.998
V_G	0.100	0.100	0.100	0.100	0.100	0.100
ρ_{M1}	1.123	1.123	1.123	1.123	1.123	1.123
V_{M1}	0.077	0.077	0.077	0.077	0.077	0.077
ρ_{M2}	1.118	1.118	1.118	1.118	1.320	1.536
V_{M2}	0.121	0.121	0.121	0.121	0.121	0.121
ρ_P	1.169	1.279	1.001	1.116	1.168	1.208
V_P	0.157	0.111	0.090	0.098	0.168	0.154
ρ_R	1.465	1.603	1.255	1.399	1.729	2.080
V_R	0.235	0.207	0.197	0.200	0.242	0.233
β	4.8	5.7	4.5	5.0	5.5	6.6

AISC						
	All	6.4 mm	12.7mm	E7014	E70T-4/E70T-7	E70T7-K2/E71T8-K6
Sample Size	86	52	34	12	54	19
No. 6.4 mm	52	54	0	9	31	11
No. 12.7 mm	34	0	34	3	23	8
ρ_G	0.998	0.998	0.998	0.998	0.998	0.998
V_G	0.100	0.100	0.100	0.100	0.100	0.100
ρ_{M1}	1.123	1.123	1.123	1.123	1.123	1.123
V_{M1}	0.077	0.077	0.077	0.077	0.077	0.077
ρ_{M2}	1.248	1.248	1.248	1.248	1.474	1.715
V_{M2}	0.121	0.121	0.121	0.121	0.121	0.121
ρ_P	1.169	1.279	1.001	1.116	1.168	1.208
V_P	0.157	0.111	0.090	0.098	0.168	0.154
ρ_R	1.636	1.790	1.401	1.562	1.930	2.322
V_R	0.235	0.207	0.197	0.200	0.242	0.233
β	4.8	5.7	4.5	5.0	5.5	6.6

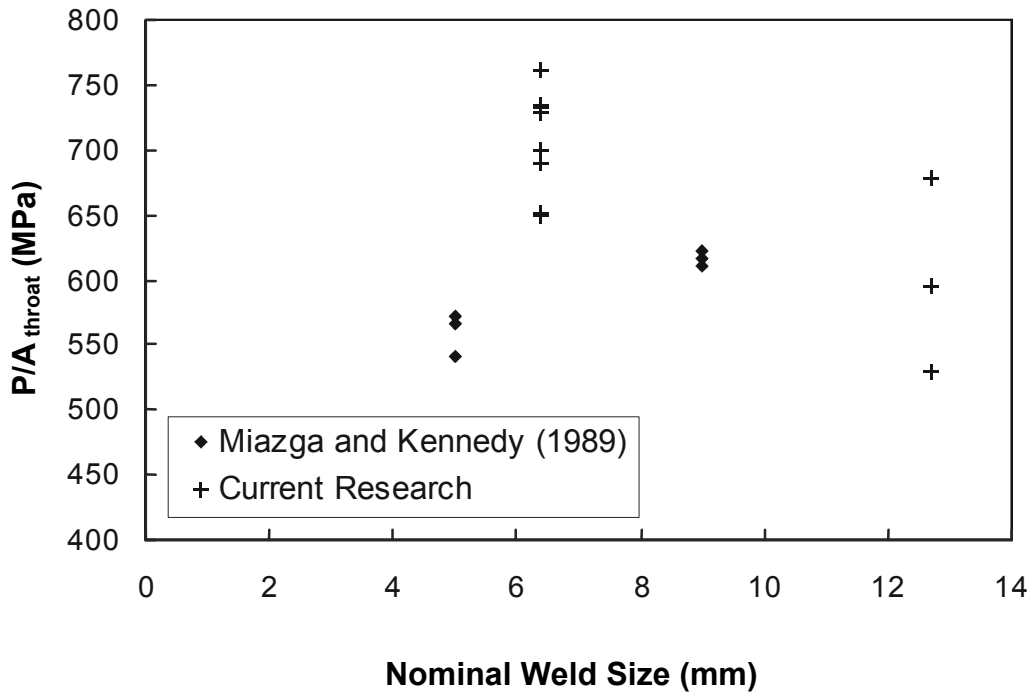

Figure 5.1 – Comparison of Weld Strength on for E7014 Filler Metal

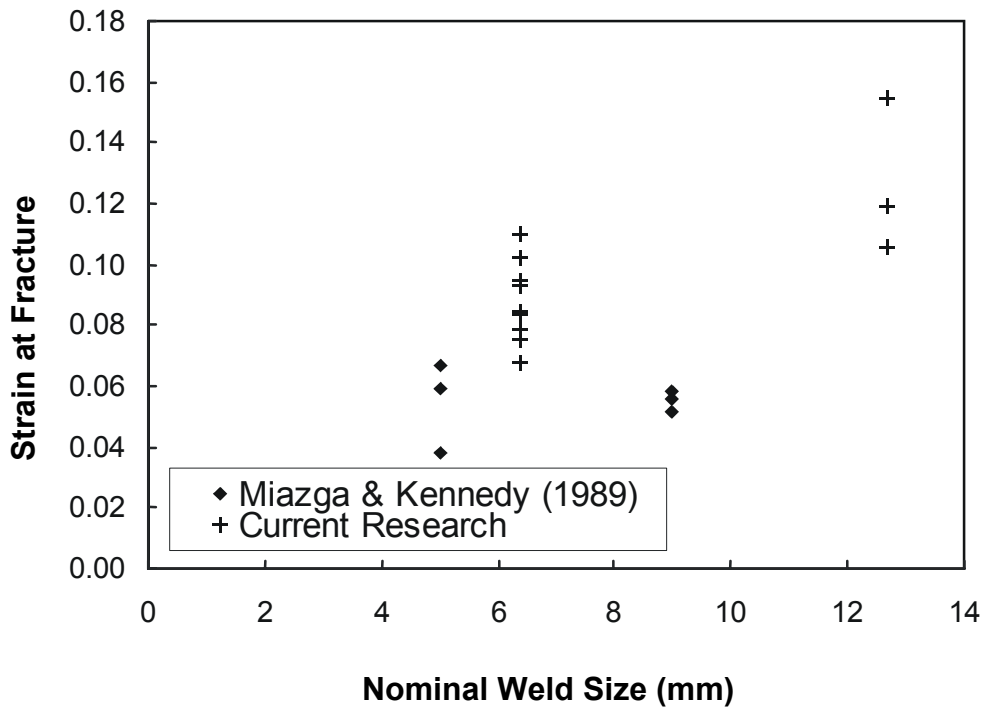
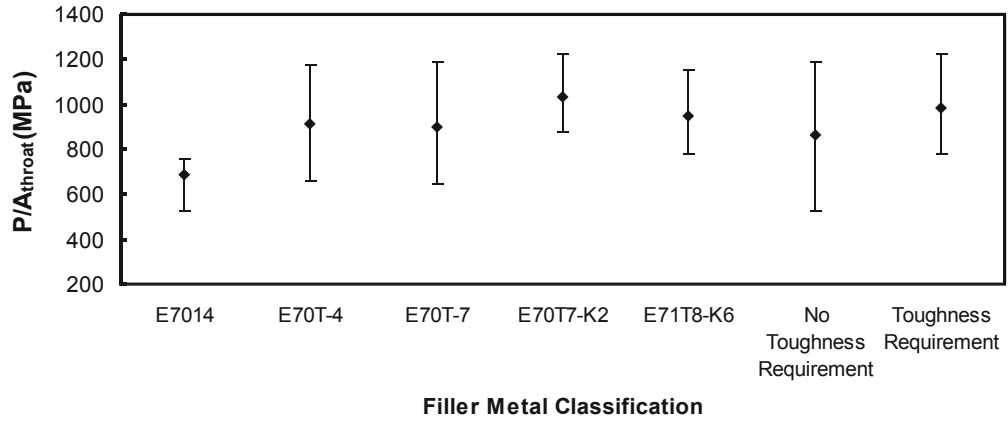
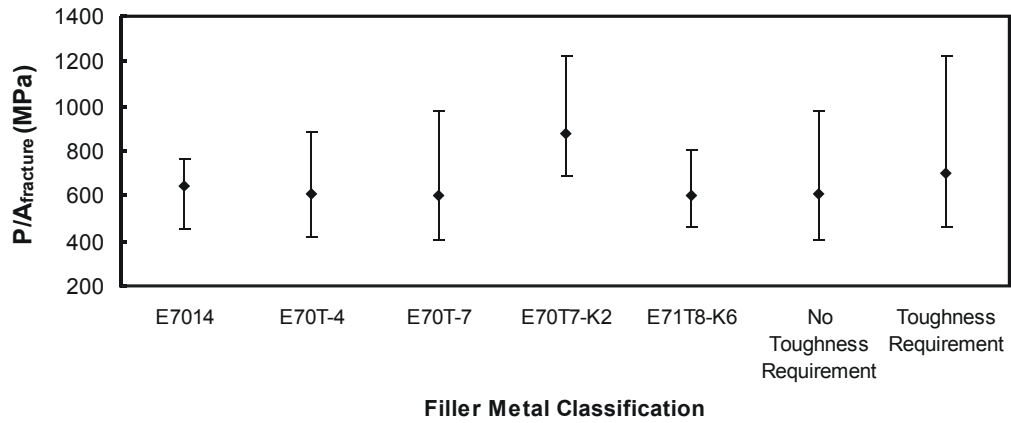

Figure 5.2 – Comparison of Weld Ductility for E7014 Filler Metal



(a) Weld Strength Calculated Using Theoretical Throat Area



(b) Weld Strength Calculated Using Fracture Surface Area

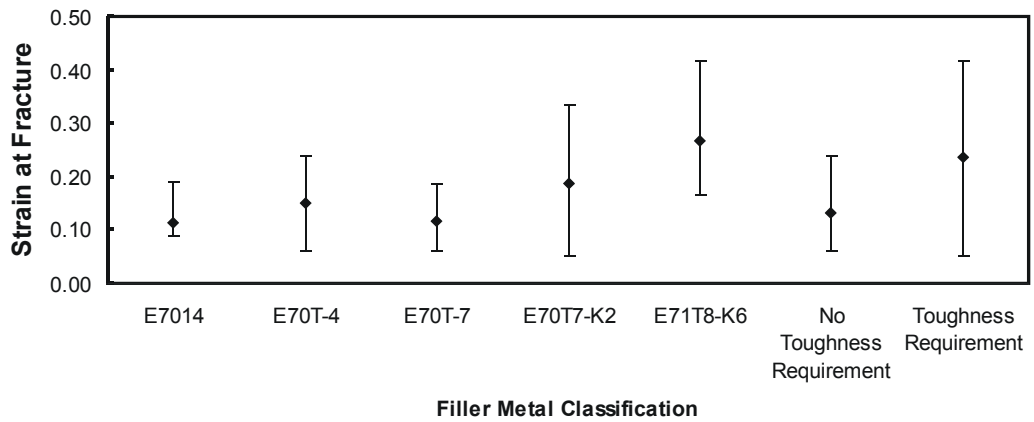

(c) Weld Ductility

Figure 5.3 – Effect of Filler Metal Classification on Fillet Weld Behaviour

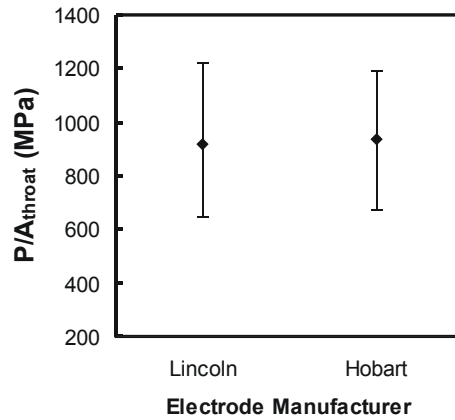

(a) Weld Strength Calculated Using Theoretical Throat Area

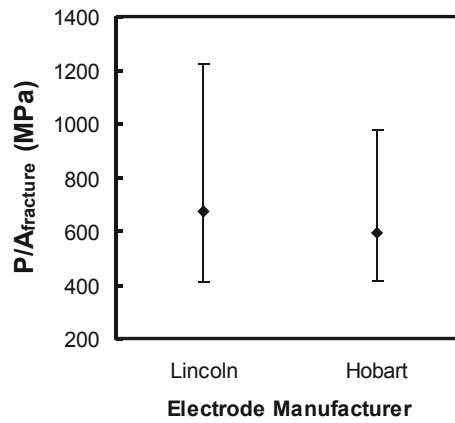

(b) Weld Strength Calculated Using Fracture Surface Area

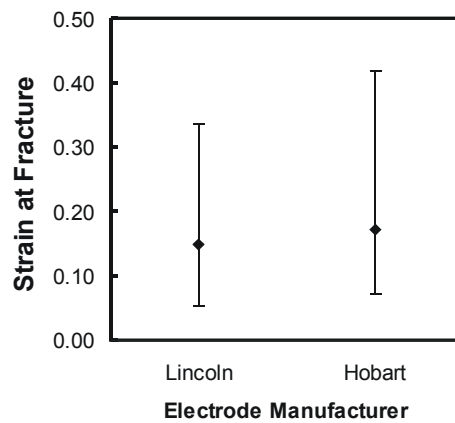

(c) Weld Ductility

Figure 5.4 – Effect of Electrode Manufacturer on Fillet Weld Behaviour

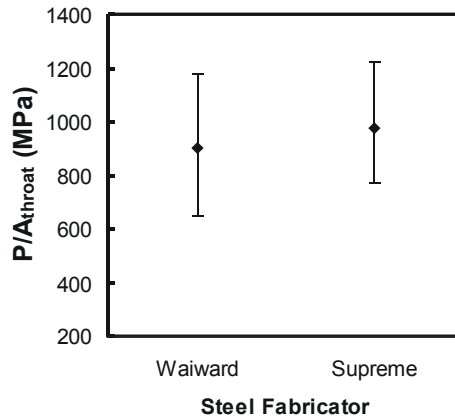

(a) Weld Strength Calculated Using Theoretical Throat Area

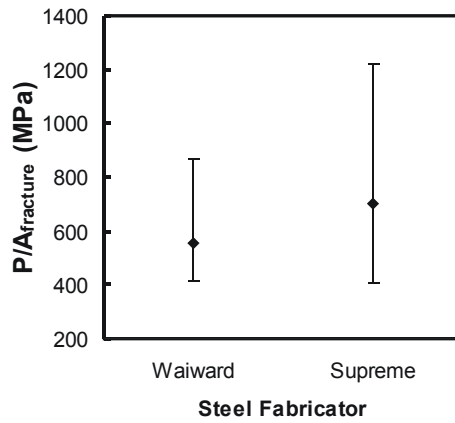

(b) Weld Strength Calculated Using Fracture Surface Area

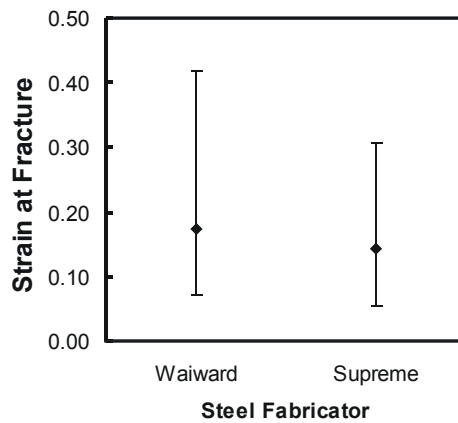

(c) Weld Ductility

Figure 5.5 – Effect of Steel Fabricator on Fillet Weld Behaviour

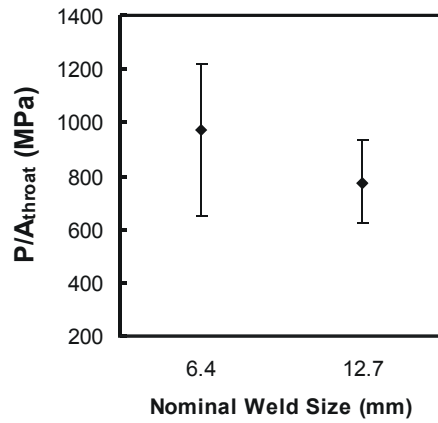

(a) Weld Strength Calculated Using Theoretical Throat Area

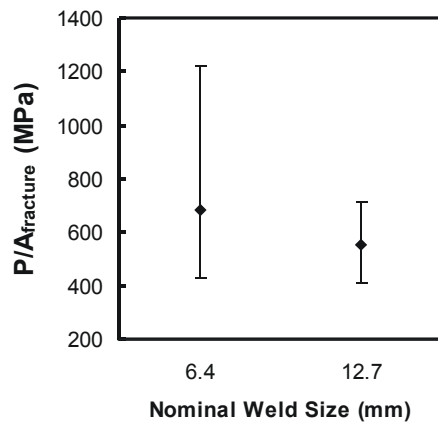

(b) Weld Strength Calculated Using Fracture Surface Area

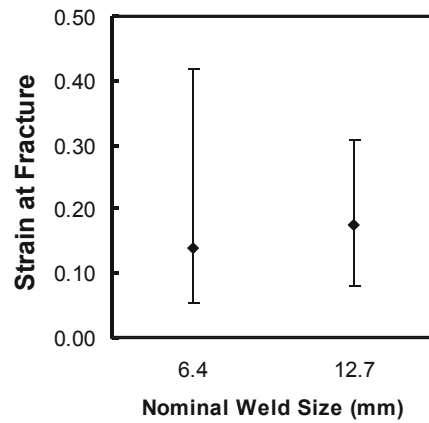

(c) Weld Ductility

Figure 5.6 – Effect of Weld Size on Fillet Weld Behaviour

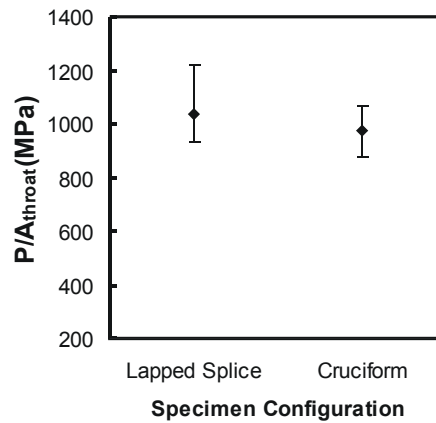

(a) Weld Strength Calculated Using Theoretical Throat Area

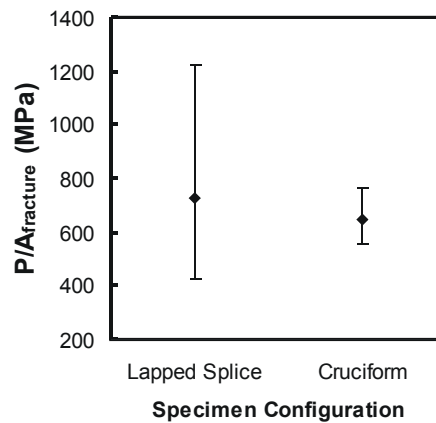

(b) Weld Strength Calculated Using Fracture Surface Area

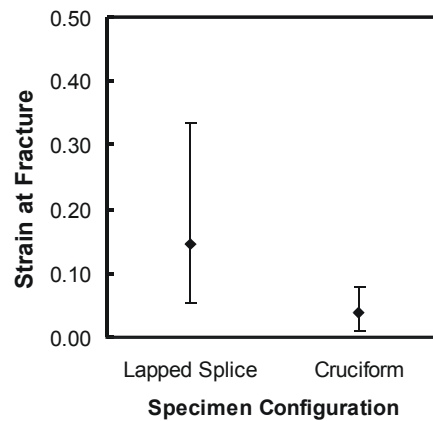

(c) Weld Ductility

Figure 5.7 – Effect of Root Notch Orientation on Fillet Weld Behaviour

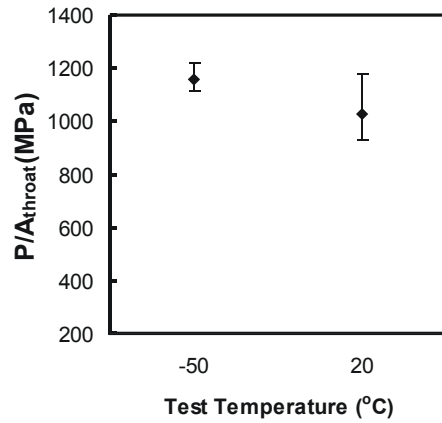

(a) Weld Strength Calculated Using Theoretical Throat Area

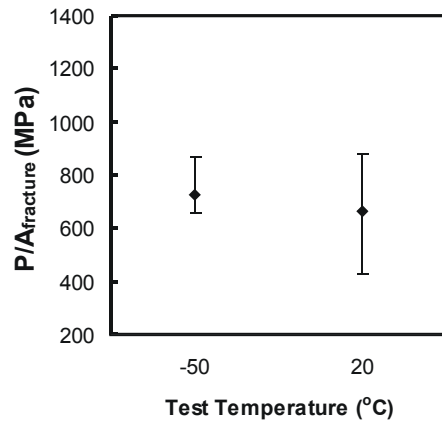

(b) Weld Strength Calculated Using Fracture Surface Area

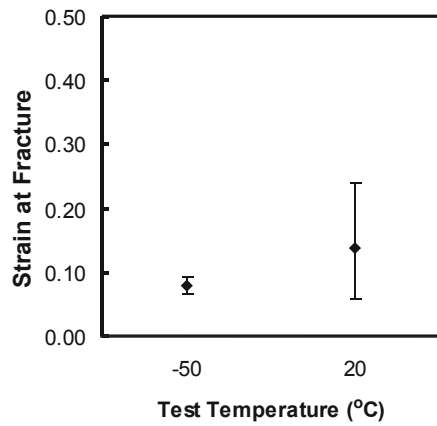

(c) Weld Ductility

Figure 5.8 - Effect of Low Temperature on Fillet Weld Behaviour

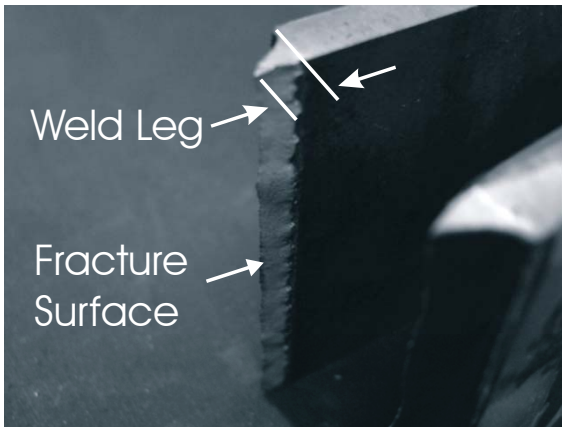

(a) Lap Plate of E7014 Specimen

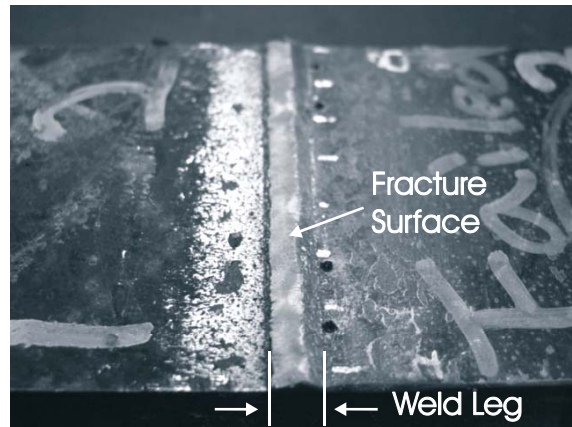

(b) Main Plate of E7014 Specimen

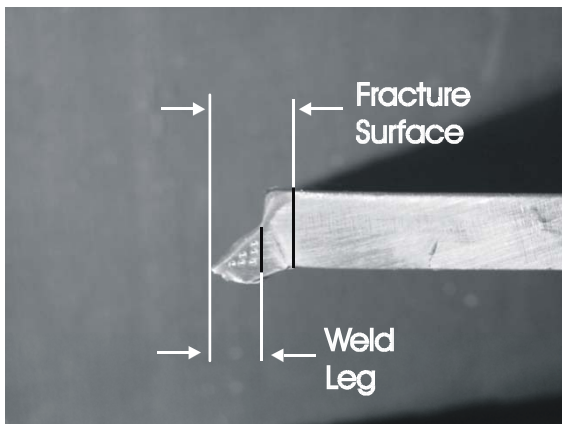

(c) Lap Plate of E70T-4 Specimen

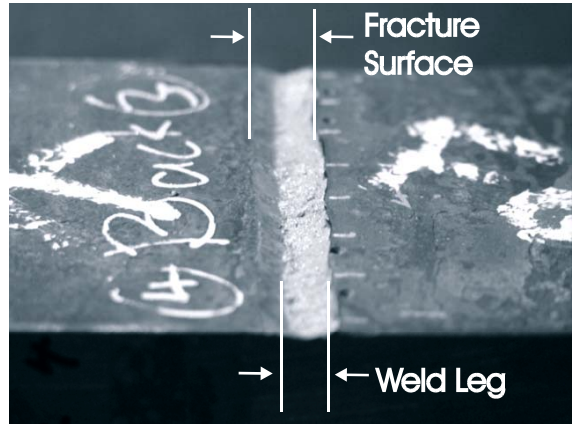

(d) Main Plate of E70T-4 Specimen

Figure 5.9 – Fracture Surface of SMAW and FCAW Specimens

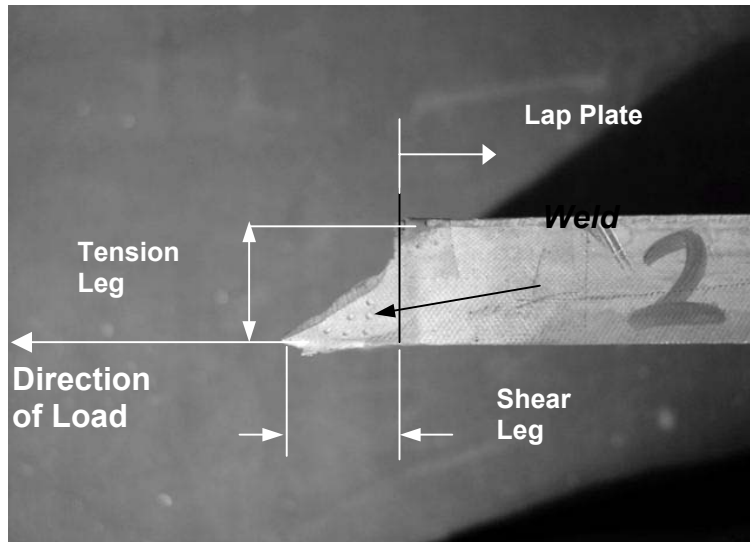

(a) 0° Fracture Angle

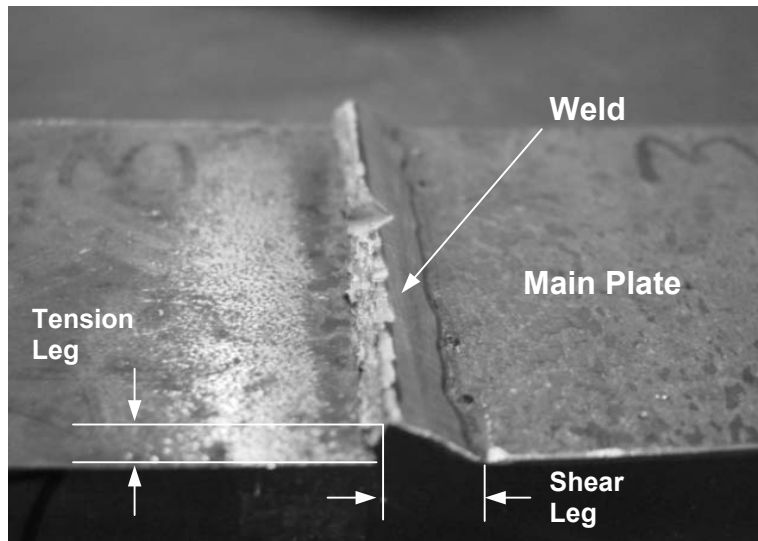

(b) 90° Fracture Angle

Figure 5.10 – Typical Weld Fracture Surfaces

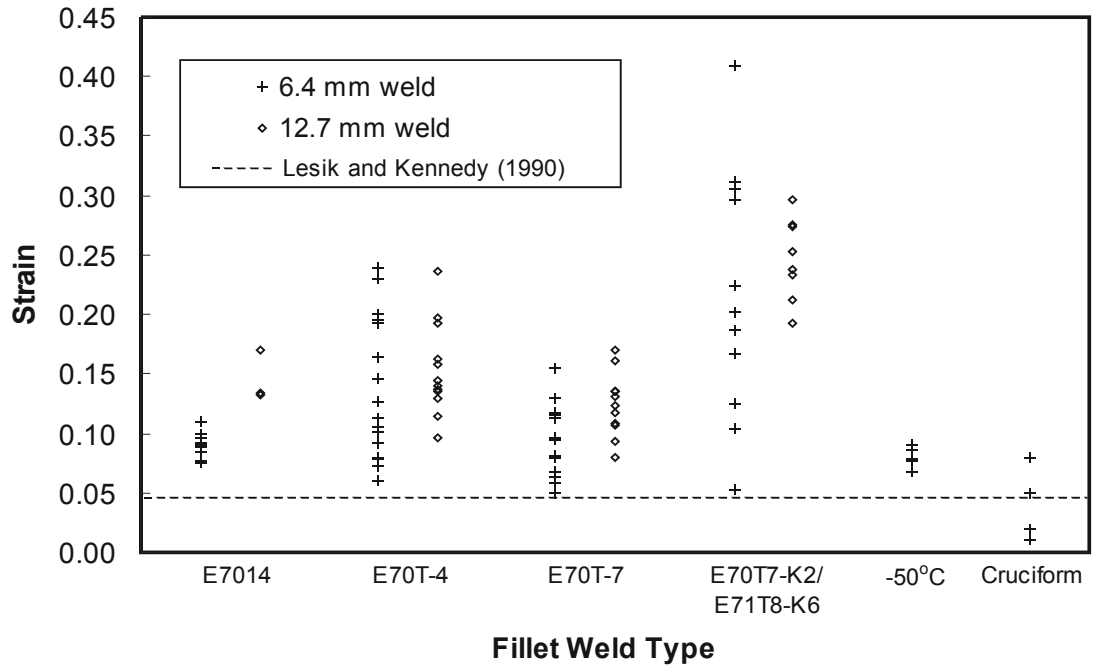

(a) Fillet Weld Ductility at Ultimate Load

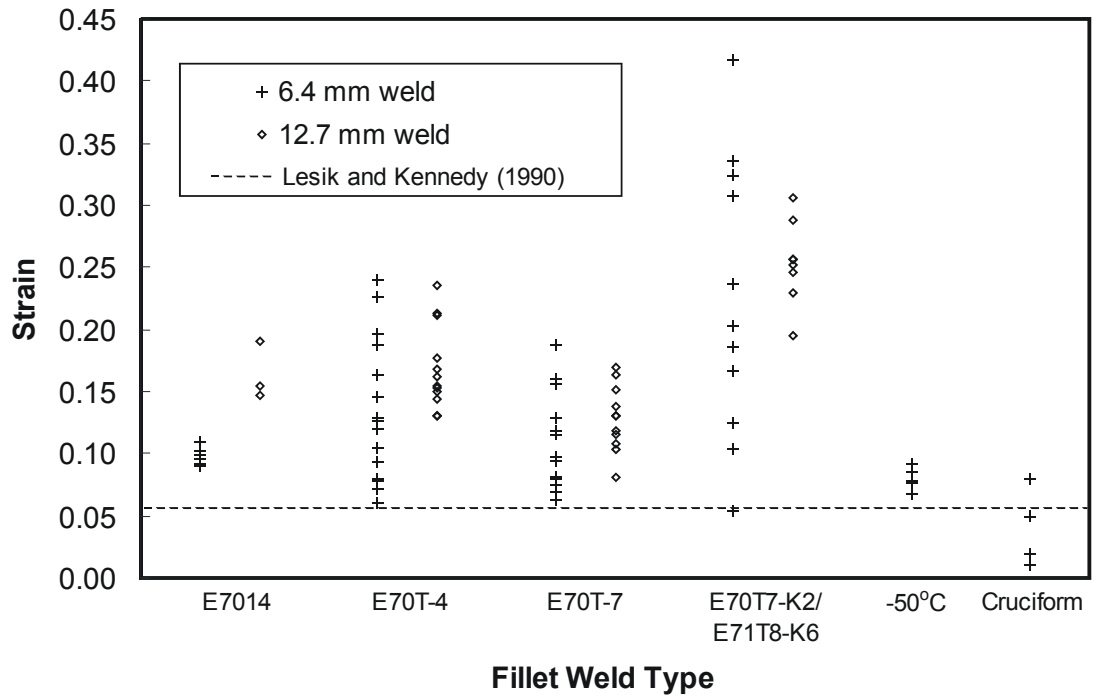

(b) Fillet Weld Ductility at Fracture

Figure 5.11 – Fillet Weld Ductility Summary

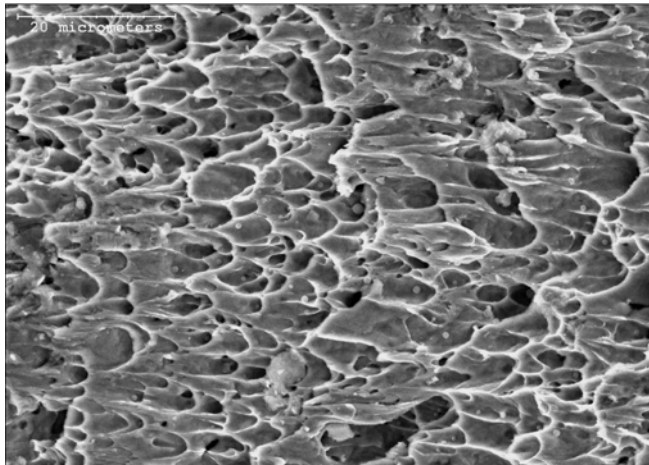

(a) Microvoid Coalescence on Fracture Surface of Specimen T2-3

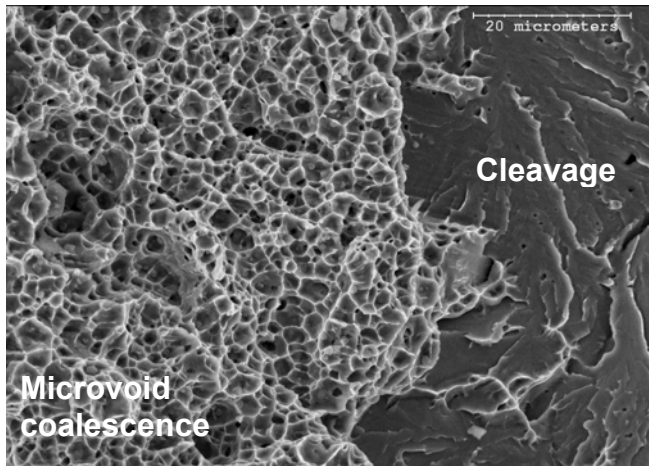

(b) Cleavage and Microvoid Coalescence on Fracture Surface of Specimen T13-1

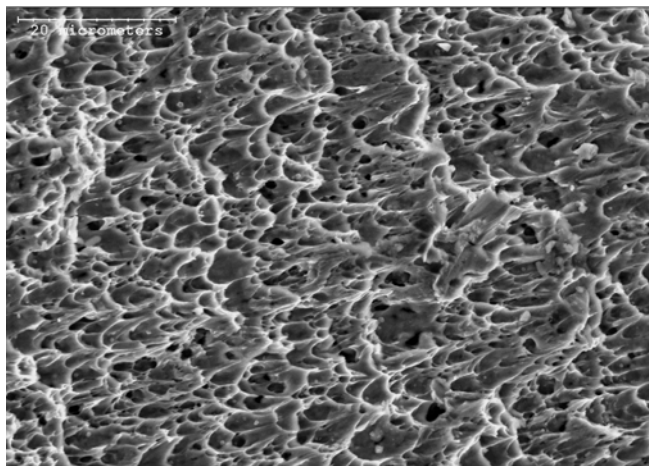

(c) Elongated Microvoids on Fracture Surface of Specimen T32-2

Figure 5.12 – Fracture Surface of Fillet Weld

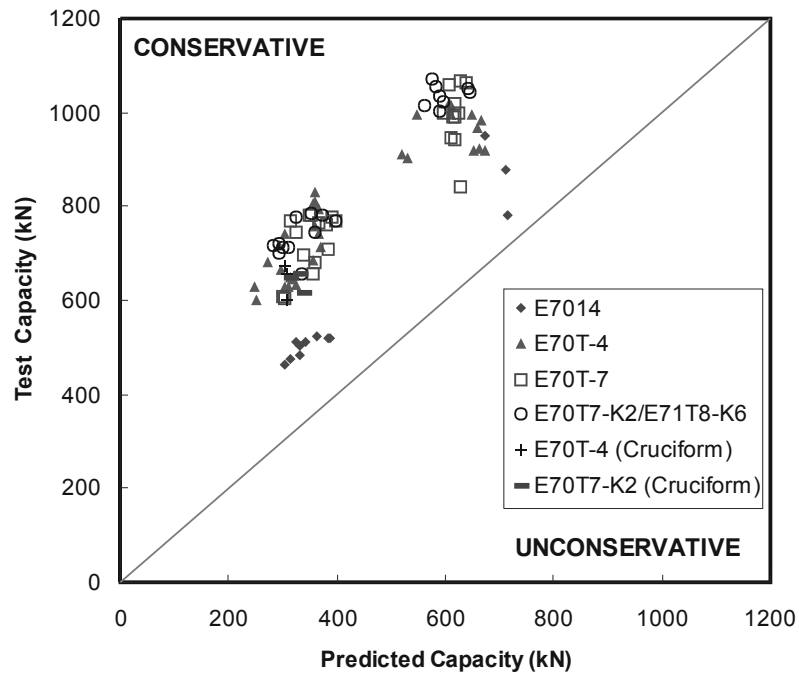

(a) Predicted Capacity Using Nominal Strength

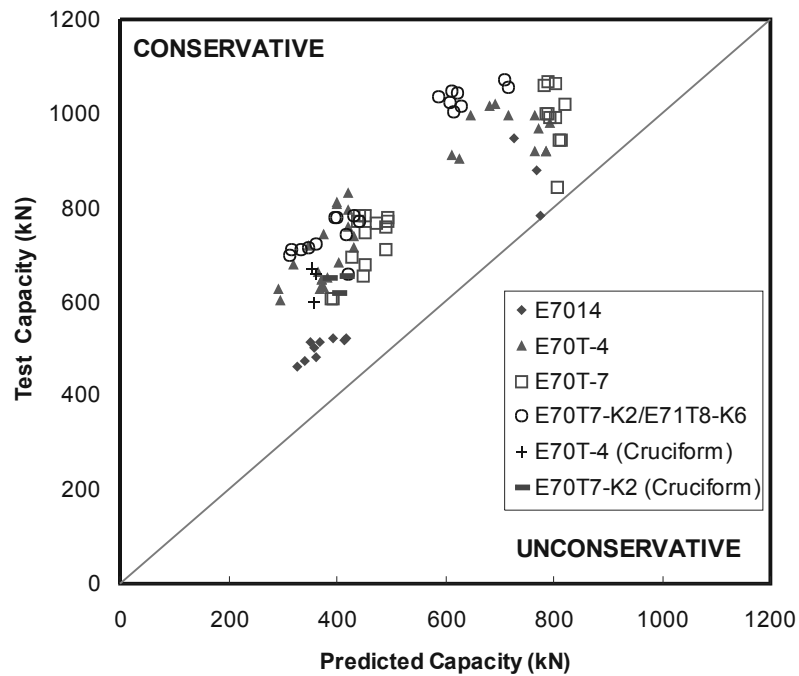

(b) Predicted Capacity Using Measured Strength

Figure 5.13 – CSA-S16 Test vs. Predicted Capacity

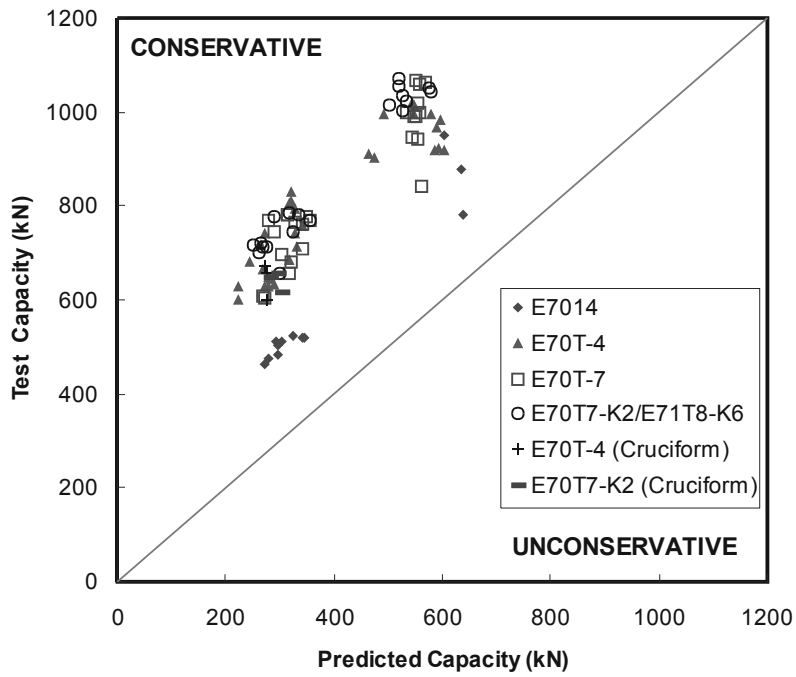

(a) Predicted Capacity Using Nominal Strength

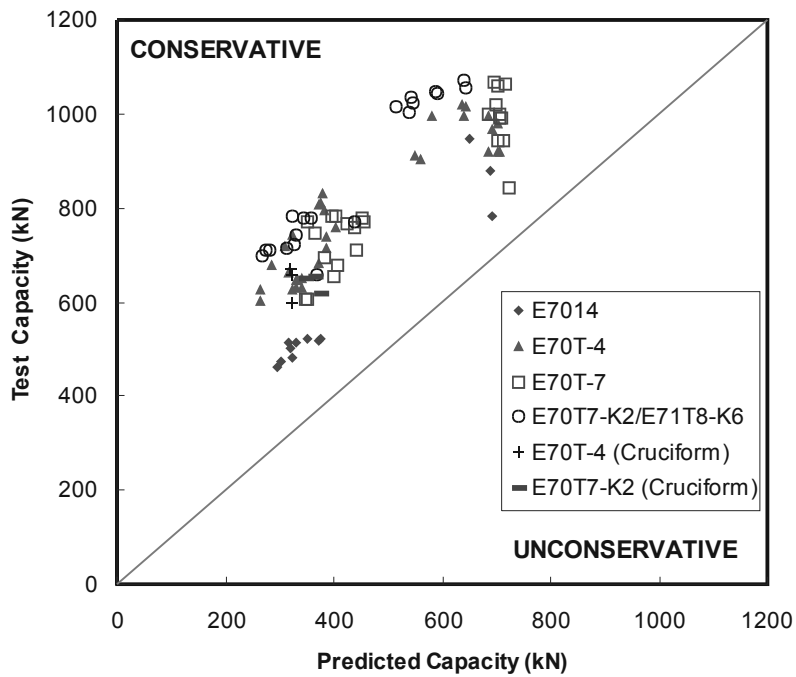

(b) Predicted Capacity Using Measured Strength

Figure 5.14 – AISC Test vs. Predicted Capacity

6.1 SUMMARY AND CONCLUSIONS

A literature review has shown that although research on the behaviour of fillet welds has focused mainly on filler metals without a specified toughness, the level of toughness inherent in the filler metals tested was not evaluated. Because SMAW electrodes were used in most of the research, the level of weld toughness in previous tests may not be representative of FCAW electrodes without a specified toughness. This has raised concerns that the design equations used currently in North America may not be adequate. Also the majority of research has been focused on fillet welds in a lapped splice configuration, but relatively fewer tests on cruciform specimens have been conducted. Therefore, a comprehensive testing program was carried out that covers a broad array of variables.

In total, 102 transverse fillet weld specimens were tested. The test matrix includes 96 double lapped splice and six cruciform specimens. Test specimens were prepared using five classifications of filler metal, namely E7014, E70T-4, E70T-7, E70T7-K2, and E71T8-K6. The E7014 filler metal is deposited using the SMAW process, while the remainder use the FCAW process. Of the classifications of filler metal tested, only the E70T7-K2 and E71T8-K6 electrodes have a specified toughness. Two weld sizes were included in the lapped splice specimens, namely 6.4 mm and 12.7 mm. On the other hand, only 6.4 mm fillet welds were included in the cruciform specimens, considered to be pilot tests to guide future work on the effect of the root notch orientation on fillet weld behaviour. Three E70T-4 specimens with 6.4 mm fillet welds from the 96 lapped splice specimens were tested at $-50^{\circ}C$ to provide an indication of the effect of low temperature on both strength and ductility. In order to provide a broad sample of specimens, electrodes from two manufacturers were used, and specimens were produced by two different fabricators. All base plates were designed to yield prior to fracture of the weld, except in the cases of the 6.4 mm E7014 specimens where the base plates were designed to remain elastic in order to conduct a direct comparison to the results from Miazga and Kennedy (1989).

All stress quantities reported herein were calculated by half of the applied load divided by either the theoretical throat area or by the measured fracture surface area.

Both areas were used for normalization because these stress quantities were used for comparison and there were advantages and disadvantages of each method. Using the theoretical throat area neglected the significant contribution of root penetration and weld face reinforcement. In most cases, fracture planes did not lie on the theoretical throats. On the other hand, using fracture surface area resulted in a true ultimate strength, but the fracture angles varied. Therefore, when comparing strengths among specimens using the second method, no one-to-one comparison can be made. Using both normalization methods can give a more general interpretation of the results. In all strain quantities reported herein, the strain at each LVDT location was calculated by dividing the deformation by the pretest measured gauge length. Weld deformations were measured using customized instrumentations to ensure the deformation captured was only the weld deformation, but not including the deformation of the base plate.

Test results of the E7014 (SMAW) specimens were compared with those tested by Miazga and Kennedy (1989). The difference of heat input, due to differences in welding speed and current used in production, and the tempering taking place in the multi-pass process can explain the difference in weld strength observed in the two research programs. However, the difference in weld strength between the 5 mm and 9 mm fillet welds from Miazga and Kennedy (1989) cannot be explained by any of the welding parameters reported. The two sizes of fillet weld in the present research exhibited higher ductility than the similar sizes of fillet weld in Miazga and Kennedy (1989). It is found that when heat input is constant, a larger weld size results in higher ductility. The differences in the welding parameters used in the two research programs can be used to explain most of the modest differences in fillet weld behaviour. The new research is therefore considered to be substantially consistent with the methods of Miazga and Kennedy (1989), and meaningful comparisons can be made with the results for the FCAW fillet welds.

It is found that the welding process itself (SMAW or FCAW) has little effect on fillet weld strength. However, it is observed that FCAW filler metal provides relatively higher penetration because for the majority of FCAW specimens, the fracture surface areas are in the order of about 1.5 to 2 times larger than the theoretical throat areas. On the other hand, for the majority of SMAW specimens, the fracture surface areas are

similar to the theoretical throat areas. Fillet welds made with filler metals with a specified toughness tend to possess a somewhat higher strength than filler metals without. Fillet welds made with filler metals having a specified toughness also showed more variability in strength. Furthermore, filler metals with a specified toughness showed significantly higher fillet weld ductility.

Electrode manufacturer and steel fabricator are found to influence fillet weld strength and ductility somewhat. However these parameters cannot reasonably be incorporated into design equations. Furthermore, there is likely a statistical interaction between the effects of electrode manufacturer and steel fabricator and the electrode classification because some fabricators reported that the lack of experience of a welder using a particular classification of electrodes caused difficulties that might affect the behaviour of fillet welds.

Smaller fillet welds tend to provide significantly higher strength and somewhat lower ductility than larger fillet weld. Smaller fillet welds also exhibit more variability in fracture strain. It is confirmed that fillet weld capacity is not linearly proportional to weld size.

Root notch orientation has slight influence on the strength of fillet weld. Fillet welds in the weldment having a cruciform configuration tended to provide a lower strength. They also tended to provide significantly lower ductility than in the lapped splice configuration.

Low temperature does not have a negative effect on fillet weld strength, but as expected, the ductility of fillet welds at low temperature tends to reduce significantly.

Unequal leg dimension was found to influence the fracture angle. In general, a 0° fracture angle appears when the dimensions of the shear and tension leg are similar. A 90° fracture angle appears while the tension leg is significantly smaller than the shear leg. Fracture surfaces of test specimens fractured at or close to 0° exhibited ductile shear fracture. Fracture surfaces of test specimens fractured at or close to 90° exhibited tension fracture, with some areas of cleavage. Test specimens fractured close to 20° show typically ductile fracture surfaces.

The ductilities of all test specimens were compared to the predicted values from the empirical equations presented by Lesik and Kennedy (1990). All lapped splice specimens tested in this research exceeded these predictions. Only the cruciform specimens fell consistently below the predicted values.

It is confirmed that the current design equations of CSA-S16 and Appendix J of the AISC Specification are conservative for filler metals with and without specified toughness, and for SMAW and FCAW process. The test-to-predicted ratio ranges from 1.25 to 2.46 and 1.39 to 2.75 for CSA-S16 and the AISC Specification, respectively, when the nominal filler metal tensile strength is used to compute the predicted capacity. The ranges of test/predicted ratios are reduced to 1.14 to 2.30 and 1.28 to 2.57 for CSA-S16 and the AISC Specification, respectively, when the measured filler metal strength is used.

Fillet welds made with filler metals with a specified toughness (E70T7-K2 and E71T8-K6) tend to provide the highest test/predicted ratios. In general, fillet welds made with FCAW filler metals without a specified toughness (E70T-4 and E70T-7) tend to provide lower test/predicted ratios than those made with filler metals with a specified toughness, but higher than those made with SMAW filler metal (E7014). For CSA-S16, the mean test/predicted ratios for the E7014, E70T-4, E70T-7, E70T7-K2, and E71T8-K6 filler metals individually are 1.42, 1.90, 1.86, 2.17, and 1.97, respectively, when predicted using the nominal weld metal strength, and 1.31, 1.62, 1.44, 1.75, and 1.86, respectively, when predicted using the measured weld metal strength. For the AISC specification, the mean test/predicted ratios for the E7014, E70T-4, E70T-7, E70T7-K2, and E71T8-K6 filler metals individually are 1.59, 2.12, 2.08, 2.42, and 2.20, respectively, when predicted using the nominal weld metal strength, and 1.46, 1.80, 1.63, 1.97, and 2.15, respectively, when predicted using the measured weld metal strength. The mean test/predicted ratios for the 6.4 mm, lapped splice fillet welds, and fillet welds tested at -50°C are higher than those for the 12.7 mm, cruciform fillet welds, and fillet welds tested at room temperature, respectively.

The safety indices, β , were evaluated for transverse fillet welds based on the results of this test program using the same procedure as Lesik and Kennedy (1990). The

safety indices were determined for the variables considered in the research, broken down into six categories, All, 6.4 mm, 12.7 mm, E7014, E70T-4/E70T-7, and E70T7-K2/E71T8-K6. Safety indices for all categories are at least equal to the traditional target value for connections of 4.5. The value of the safety index determined from all of the tests, 6.4 mm fillet welds, 12.7 mm welds, fillet welds made with E7014 filler metal, fillet welds made with FCAW filler metals without a specified toughness (E70T-4/E70T-7), and fillet welds made with filler metals with a specified toughness (E70T7-K2/E71T8-K6) are 4.8, 5.7, 4.5, 5.0, 5.5, and 6.6, respectively. The safety indices for fillet welds in cruciform configuration and tested at $-50^{\circ}C$ were not determined because the sample sizes of these special cases are very limited.

6.2 FUTURE WORK

All of the 6.4 mm specimens made with E7014 electrodes in the present research had base plates that remained elastic throughout the tension test, as did the 5 mm specimens in the work of Miazga and Kennedy (1989). Although the base plates of the 12.7 mm E7014 specimens in the present research yielded prior to weld fracture and had the same number of passes as the 9 mm specimens of Miazga and Kennedy (1989), the weld sizes from the two research programs are not the same. Due to the known influence of weld size on capacity, there is no one-to-one comparison to assess the effect of elastic base plate on fillet weld behaviour. The influence on weld strength of the restraint gained from the base plates remaining elastic could not be determined with confidence. There is a need for further investigation on the influence of yielding of the base plates on fillet weld strength and ductility.

Including the six cruciform specimens in this research program, the available data on fillet weld in weldments having a cruciform configuration is still very limited. The test results of these six specimens show that transverse fillet welds in a cruciform configuration tend to provide both lower weld strength and ductility. Experimental work on fillet welds in a cruciform configuration should be expanded (including different weld

sizes) to investigate the effect of weldment geometry on fillet weld behaviour in order to determine the safety index for this specific configuration.

For fillet welds at low temperature, the available data is very limited. Although the test results from the present research program did not show that low temperature has a negative effect on fillet weld strength, the available data is not enough to determine the safety index for this specific category. Further investigation is needed to expand the data pool for fillet welds at low service temperatures.

Phases II and III of this research project are currently in progress. Phase II is an investigation similar in structure to the research reported herein (Phase I) and covers the behaviour of longitudinal and 45° fillet welds made with FCAW filler metals. Phase III is an investigation of the behaviour of welds groups, with combinations of transverse and longitudinal fillet welds and transverse and 45° fillet welds.

REFERENCES

- AISC. 1999. "Load and Resistance Factor Design Specification for Structural Steel Buildings," American Institute of Steel Construction, Chicago, IL.
- ASTM. 2000. "Standard Specification for High-Strength Low-Alloy Columbium-Vanadium Structural Steel," A572/A572M-00, American Society for Testing and Materials, Philadelphia, PA.
- ASTM. 1997. "Standard Test Methods and Definitions for Mechanical Testing of Steel Products," A370-97a, American Society for Testing and Materials, Philadelphia, PA.
- AWS. 1998. "Specification for Low-Alloy Steel Electrodes for Flux Cored Arc Welding," ANSI/AWS A5.29-98, American Welding Society, Miami, FL.
- AWS. 1995. "Specification for Carbon Steel Electrodes for Flux Cored Arc Welding," ANSI/AWS A5.20-95, American Welding Society, Miami, FL.
- AWS. 1991. "Specification for Carbon Steel Electrodes for Shielded Metal Arc Welding," ANSI/AWS A5.1-91, American Welding Society, Miami, FL.
- Biggs, M. S., Crofts, M. R., Higgs, J. D., Martin L. H., and Tzogius, A. 1981. "Failure of Fillet Weld Connections Subject to Static Loading," Joints in Structural Steelwork, Proc. Of Conf. held at Teeside Polytechnic, Pentech Press, London, England, pp. 1.92-1.109.
- Bowman, M. D., and Quinn, B. P. 1994. "Examination of Fillet Weld Strength," AISC Engineering Journal, Vol. 31, No. 3, pp. 98-108.
- Butler, L. J., and Kulak, G. L. 1971. "Strength of Fillet Welds as a Function of Direction of Load," Welding Journal, Welding Research Supplement, Vol. 36, No. 5, pp. 231s-234s.
- Butler, L. J., Pal, S., and Kulak, G. L. 1972. "Eccentrically Loaded Welded Connections," Journal of the Structural Division, ASCE, Vol. 98, ST5, May, pp. 989-1005.

- Clark, P. J. 1971. "Basis of Design For Fillet-Welded Joints Under Static Loading," Proc. Conf. On Improving Welded Product Design, The Welding Institute, Cambridge, England, Vol 1, pp. 85-96.
- CSA. 2001a. "Filler Metals and Allied Materials for Metal Arc Welding," CSA W48-01, Canadian Standards Association, Rexdale, ON.
- CSA. 2001b. "Limit States Design of Steel Structures," CSA S16-01, Canadian Standards Association, Rexdale, ON.
- Deng, K. 2002. "The effect of loading angle on the behaviour of fillet welds," Masters Thesis, (In preparation) Department of Civil and Environmental Engineering, University of Alberta, Edmonton, AB.
- Fisher, J. W., Galambos, T.V., Kulak, G. L., and Ravindra, M. K. 1978. "Load and Resistance Factor Design Criteria for Connectors," Journal of the Structural Division, ASCE, Vol. 104, No. ST9, Sept., pp. 1427-1441.
- Freeman, F. R. 1931. "The Strength of Arc-Welded Joints," Minutes of Proceedings of Institution of Civil Engineers, 231, pp. 283-366.
- Franchuk, C. R., Driver, R. G., and Grondin, G. Y. 2002. "Block Shear Behaviour of Coped Steel Beams," Structural Engineering Report 244, Department of Civil and Environmental Engineering, University of Alberta, Edmonton, AB.
- Galambos, T. V. and Ravindra, M. K. 1973. "Tentative Load and Resistance Factor Design Criteria for Steel Buildings," Research Report No. 18, Civil Engineering Department, Washington University, St. Louis, MO.
- Higgins, T. R. and Preece, F. R. 1969. "Proposed Working Stresses For Fillet Welds in Building Construction," Engineering Journal, AISC, Vol. 6, No. 1, pp. 16-20.
- Iwankiw, N. R. 1997. "Rational Basis for Increased Fillet Weld Strength," AISC Engineering Journal, Vol. 34, No.2, pp. 68-71.
- Kamtekar, A. G. 1987. "The Strength of Inclined Fillet Welds," Journal of Constructional Steel Research, Vol. 7, No. 1, pp. 43-54.

- Kamtekar, A. G. 1982. "A New Analysis of the Strength of Some Simple Fillet Welded Connections," *Journal of Constructional Steel Research*, Vol. 2, No. 2, pp. 33-45.
- Kato, B., and Morita, K. 1969. "The Strength of Fillet Welded Joints, IIW Document XV-267-69," International Institute of Welding.
- Kato, B., and Morita, K. 1974. "Strength of Transverse Fillet Welded Joints," *Welding Journal, Welding Research Supplement*, pp. 59s-64s.
- Kennedy, D. J. L., and Kriviak, G. J. 1985. "The Strength of Fillet Welds Under Longitudinal and Transverse Shear: A Paradox," *Canadian Journal of Civil Eng.*, Vol. 12, pp. 226-231.
- Lesik, D. F., and Kennedy, D. J. L. 1988. "Ultimate Strength of Eccentrically Loaded Fillet Welded Connections," *Structural Engineering Report 159*, Department of Civil Engineering, University of Alberta, Edmonton, AB.
- Lesik, D. F., and Kennedy, D. J. L. 1990. "Ultimate Strength of Fillet Welded Connections Loaded in Plane," *Canadian Journal of Civil Engineering*, Vol. 17, No. 1, pp. 55-67.
- Ligtenburg, F. K. 1968. "International Test Series, Final Report. IIW Document XV-242-68," International Institute of Welding.
- Mansell, D. S., and Yadav, A. R. 1982. "Failure Mechanisms in Fillet Welds," *Proceedings of Eighth Australian Conference on Mechanics of Structures and Materials, ACMSM 8*, August, pp. 25.1-25.6.
- Miazga, G. S., and Kennedy, D. J. L. 1986. "Behaviour of Fillet Welds as a Function of the Angle of Loading," *Structural Engineering Report 133*, Department of Civil Engineering, University of Alberta, Edmonton, AB.
- Miazga, G. S., and Kennedy, D. J. L. 1989. "Behaviour of Fillet Welds as a Function of the Angle of Loading," *Canadian Journal of Civil Engineering*, Vol. 16, No. 4, pp. 583-599.
- Pham, L. 1983a. "Co-ordinated Testing of Fillet Welds Part 1 - Cruciform Specimens," *Australian Welding Research*, Vol. 12, December, pp. 16-25.

- Pham, L. 1983b. "Co-ordinated Testing of Fillet Welds Part 2 - Werner Specimens," Australian Welding Research, Vol. 12, December, pp. 54-60.
- Ravindra, M. K., and Galambos, T. V. 1978. "Load and Resistance Factor Design for Steel," ASCE Journal of the Structural Division, Vol. 104, No. ST9, Sept. pp. 1337-1353.
- Swannell, P. 1981a. "Rational Design of Fillet Weld Groups," Journal of the Structural Division, ASCE, Vol. 107, No. ST5, May, pp. 789-802.
- Swannell, P. 1981b. "Weld Group Behavior," Journal of the Structural Division, ASCE, Vol. 107, No. ST5, May, pp. 803-815.
- Swannell, P., and Skewes, I. C. 1979. "The Design of Welded Brackets Loaded In Plane: Elastic and Ultimate Load Techniques - AWRA Report P6-8-77," Australian Welding Research, Jan, pp. 28-59.

Appendix A
Welding Procedure Specifications

Table A1 – Welding Procedure Specifications prepared by Waiward

Filler Metal: Fabshield 4		Stick-out: 2.5"				Weld Detail		
Pass #	Class	Dia.	Polarity	Wire Feed Speed	Amperage		Volts	Travel Speed
1	E70T-4	3/32	DC+	221	390/400A	32.5	27	
Filler Metal: Fabshield 4		Stick-out: 2.5"				Weld Detail		
Pass #	Class	Dia.	Polarity	Wire Feed Speed	Amperage		Volts	Travel Speed
1	E70T-4	3/32	DC+	221	390/400A	32.5	27	
2, 3				221	390/400A	32.5	16, 17	
Filler Metal: Fabshield 4		Stick-out: 2.5"				Weld Detail		
Pass #	Class	Dia.	Polarity	Wire Feed Speed	Amperage		Volts	Travel Speed
1-10	E70T-4	3/32	DC+	221	390/400A	32.5	16-17	
Filler Metal: Innershield NS3M		Stick-out: 2.5"				Weld Detail		
Pass #	Class	Dia.	Polarity	Wire Feed Speed	Amperage		Volts	Travel Speed
1	E70T-4	3/32	DC+	150	310	28-29	18	

Note: All dimensions are inches
All speeds are inches/min.

Table A1 – Welding Procedure Specifications prepared by Waiward (cont'd)

Filler Metal: Innershield NS3M				Stick-out: 2.5"				Weld Detail
Pass #	Class	Dia.	Polarity	Wire Feed Speed	Amperage	Volts	Travel Speed	
1	E70T-4	3/32	DC+	150	310	28-29	18	
2,3				150	310	28-29	12, 14	
Filler Metal: Innershield NS3M				Stick-out: 2.5"				Weld Detail
Pass #	Class	Dia.	Polarity	Wire Feed Speed	Amperage	Volts	Travel Speed	
1-10	E70T-4	3/32	DC+	150	310	28-29	12-14	
Filler Metal: Fabshield 7027				Stick-out: 1.5"				Weld Detail
Pass #	Class	Dia.	Polarity	Wire Feed Speed	Amperage	Volts	Travel Speed	
1	E70T-7	3/32	DC-	214	410	28.5	21	
Filler Metal: Fabshield 7027				Stick-out: 1.5"				Weld Detail
Pass #	Class	Dia.	Polarity	Wire Feed Speed	Amperage	Volts	Travel Speed	
1	E70T-7	3/32	DC-	214	410	28.5	21	
2, 3				214	410	28.5	13, 15	

Note: All dimensions are inches
All speeds are inches/min

Table A1 – Welding Procedure Specifications prepared by Waiward (cont'd)

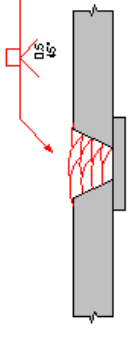
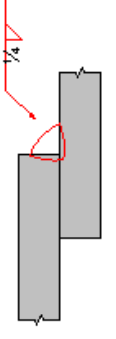
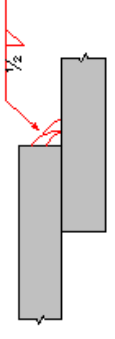
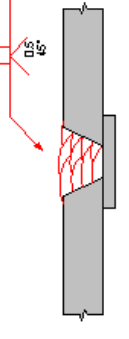
Filler Metal: Fabshield 7027		Stick-out: 1.5"					Weld Detail	
Pass #	Class	Dia.	Polarity	Wire Feed Speed	Amperage	Volts		Travel Speed
1-10	E70T-7	3/32	DC-	214	410	28.5	13-15	
Filler Metal: Innershield NR311		Stick-out: 1.25"					Weld Detail	
Pass #	Class	Dia.	Polarity	Wire Feed Speed	Amperage	Volts		Travel Speed
1	E70T-7	3/32	DC-	146	315	28	16	
Filler Metal: Innershield NR311		Stick-out: 1.25"					Weld Detail	
Pass #	Class	Dia.	Polarity	Wire Feed Speed	Amperage	Volts		Travel Speed
1	E70T-7	3/32	DC-	146	315	28	16	
2, 3				146	315	28	13, 14	
Filler Metal: Innershield NR311		Stick-out: 1.25"					Weld Detail	
Pass #	Class	Dia.	Polarity	Wire Feed Speed	Amperage	Volts		Travel Speed
1-10	E70T-7	3/32	DC-	146	315	28	13-15	

Note: All dimensions are inches
All speeds are inches/min

Table A1 – Welding Procedure Specifications prepared by Waiward (cont'd)

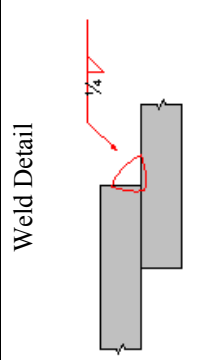
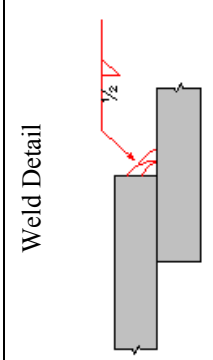
Filler Metal: Fabshield 3Ni1		Stick-out: 3/4"					Weld Detail	
Pass #	Class	Dia.	Polarity	Wire Feed Speed	Amperage	Volts		Travel Speed
1	E71T8-K6	5/64	DC-	170	310	23.5	13	
Filler Metal: Fabshield 3Ni1								
		Stick-out: 3/4"					Weld Detail	
Pass #	Class	Dia.	Polarity	Wire Feed Speed	Amperage	Volts		Travel Speed
1	E71T8-K6	5/64	DC-	170	310	23.5		13
2, 3				170	310	23.5	9, 10	
Filler Metal: Fabshield 3Ni1								
		Stick-out: 3/4"					Weld Detail	
Pass #	Class	Dia.	Polarity	Wire Feed Speed	Amperage	Volts		Travel Speed
1-15	E71T8-K6	5/64	DC-	170	310	23.5		10-13
Filler Metal: Innershield NR311Ni								
		Stick-out: 1"					Weld Detail	
Pass #	Class	Dia.	Polarity	Wire Feed Speed	Amperage	Volts		Travel Speed
1	E70T7-K2	5/64	DC-	196	280	26.5		11

Note: All dimensions are inches
All speeds are inches/min.

Table A1 – Welding Procedure Specifications prepared by Waiward (cont'd)

Filler Metal: Innershield NR311Ni				Stick-out: 1”			
Pass #	Class	Dia.	Polarity	Wire Feed Speed	Amperage	Volts	Travel Speed
1	E70T7-K2	5/64	DC-	196	280	26.5	11
2-3				196	280	26.5	10, 12

Weld Detail

Filler Metal: Innershield NR311Ni				Stick-out: 1”			
Pass #	Class	Dia.	Polarity	Wire Feed Speed	Amperage	Volts	Travel Speed
1-15	E70T7-K2	5/64	DC-	196	280	26.5	10-12

Weld Detail

Filler Metal: Lincoln E7014							
Pass #	Class	Dia.	Polarity	Wire Feed Speed	Amperage	Volts	Travel Speed
1	E7014	5/32	DC-	N/A	170	—	10

Weld Details

Filler Metal: Lincoln E7014							
Pass #	Class	Dia.	Polarity	Wire Feed Speed	Amperage	Volts	Travel Speed
1-3	E7014	5/32	DC-	N/A	170	—	10

Weld Details

Note: All dimensions are inches
All speeds are inches/min.

Table A1 – Welding Procedure Specifications prepared by Waiward (cont'd)

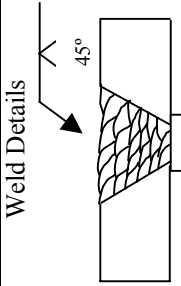
Pass #		Filler Metal: Lincoln E7014							Weld Details
		Class	Dia.	Polarity	Wire Feed Speed	Amperage	Volts	Travel Speed	
1-26		E7014	5/32	DC-	N/A	170	—	10	

Note: All dimensions are inches
All speeds are inches/min.

Table A2 – Welding Procedure Specifications prepared by Supreme

Supreme Steel Data Sheet

Date: 18-Oct-01

Job: 1072

Project: AISC - University of Alberta Fillet Weld Project

Personnel: Welder - Ed Homeniuk (Supreme Steel)
QA/Engineer - Todd Collister (Supreme Steel)

Conditions: Standard Shop Conditions

Material: See Waiward Steel for material specifications and other Information

Equipment: Welding Machine

Lincoln Electric
Model - DC-600
Code - W383-1
Type - K1288M
Serial No.- 292309

Wire Feeder

Lincoln Electric
LN-7 Wire Feeder
Code - 9168
Serial No.- 186030
Input voltage 115 50/60 Hz current 2.0 Amps

- Notes:**
- Best welds on same side were chosen based on visual inspection
 - Other side of plate was reinforced with small fillet weld
 - Groove welded specimen were welded with a maintained temperature of 150 degrees celcius
 - Temperature of plate was monitored with a temperature crayon
 - High deposit rate with wire speed at 225 made 6mm fillet weld difficult to attain
 - Nickel wire was very smokey and was difficult to see puddle and maintain size of fillet

Specimen	Mark	Producer	Filler Metal	Class	Polarity	Stick-out	Wire speed	Amps.	Volts	Date
1/4" fillet	T4-H-S	Hobart	Fabshield 4	E70T-4	DC+	2.5"	225	350	29	21-Aug
1/2" fillet	T4-H-S	Hobart	Fabshield 4	E70T-4	DC+	2.5"	225	350	29	21-Aug
GROOVE	T4-H-S	Hobart	Fabshield 4	E70T-4	DC+	2.5"	225	350	29	21-Aug
1/4" fillet	T4-L-S	Lincoln	Innershield NS3M	E70T-4	DC+	2.5"	150	310	29	16-Oct
1/2" fillet	T4-L-S	Lincoln	Innershield NS3M	E70T-4	DC+	2.5"	150	310	29	16-Oct
1/4" fillet	T7-H-S	Hobart	Fabshield 7027	E70T-7	DC-	1.5"	170	350	26	16-Oct
1/2" fillet	T7-H-S	Hobart	Fabshield 7027	E70T-7	DC-	1.5"	170	350	26	16-Oct
GROOVE	T7-H-S	Hobart	Fabshield 7027	E70T-7	DC-	1.5"	170	350	26	17-Oct
1/4" fillet	T7-L-S	Lincoln	Innershield NR311	E70T-7	DC-	1.25"	160	340	26	17-Oct
1/2" fillet	T7-L-S	Lincoln	Innershield NR311	E70T-7	DC-	1.25"	160	340	26	17-Oct
1/4" fillet	T8-K6-H-S	Hobart	Fabshield 3Ni1	E71T8-K6	DC-	.75"	180	330	24	18-Oct
1/2" fillet	T8-K6-H-S	Hobart	Fabshield 3Ni1	E71T8-K6	DC-	.75"	180	330	24	18-Oct
GROOVE	T8-K6-H-S	Hobart	Fabshield 3Ni1	E71T8-K6	DC-	.75"	180	330	24	18-Oct
1/4" fillet	T7-K2-L-S	Lincoln	Innershield NR311Ni	E70T7-K2	DC-	1"	180	310	25	18-Oct
1/2" fillet	T7-K2-L-S	Lincoln	Innershield NR311Ni	E70T7-K2	DC-	1"	180	310	25	18-Oct

Appendix B
Etched Specimen Cross-Sections

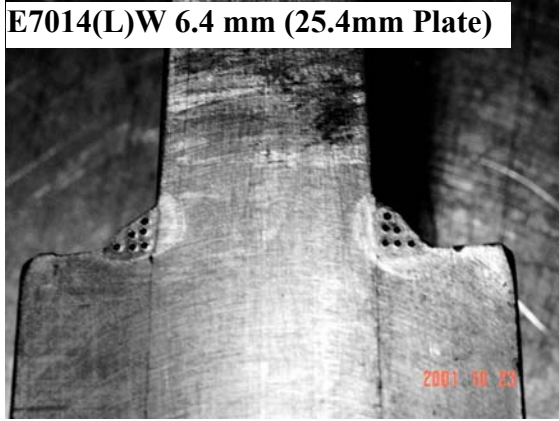

Figure B1 – Specimen T1-3

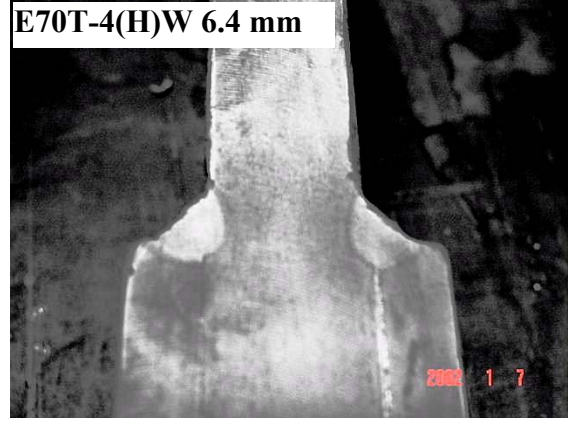

Figure B2 – Specimen T5-3

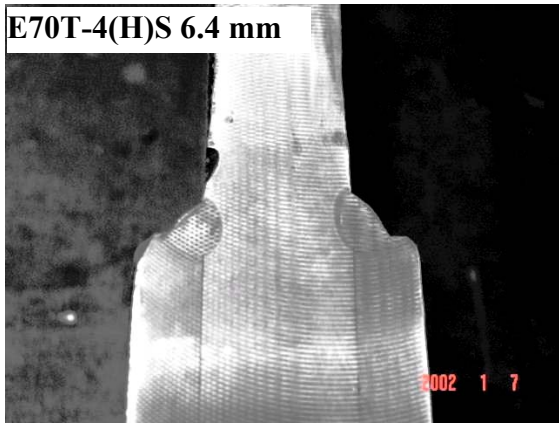

Figure B3 – Specimen T7-1

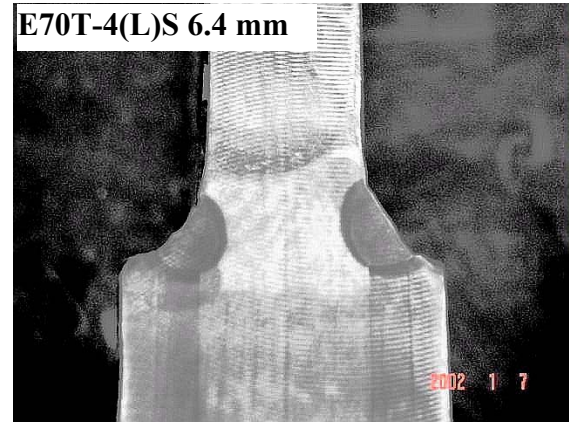

Figure B4 – Specimen T9-1

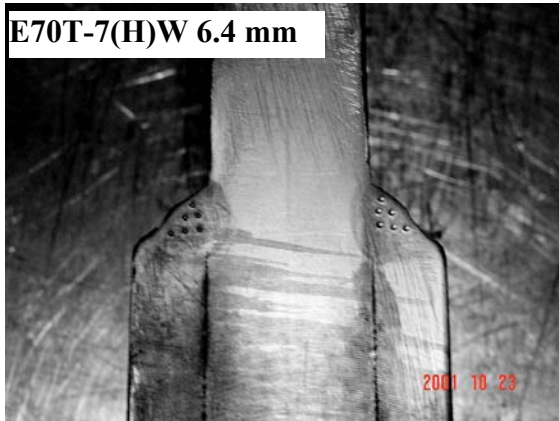

Figure B5 – Specimen T11-2

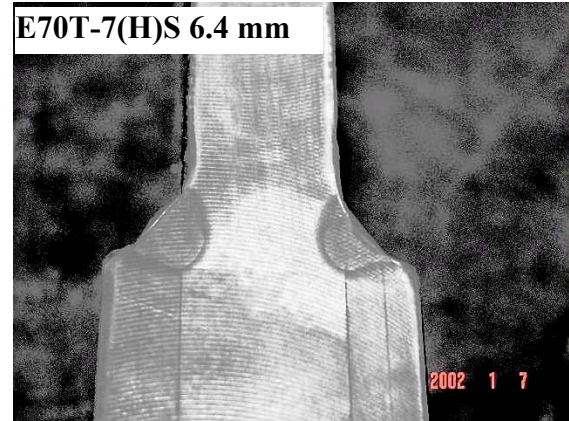

Figure B6 – Specimen T12-1

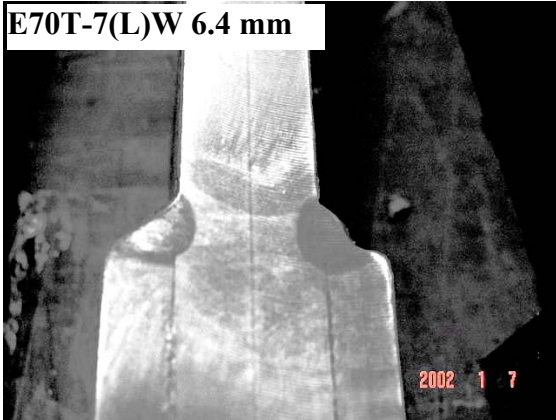

Figure B7 – Specimen T13-3

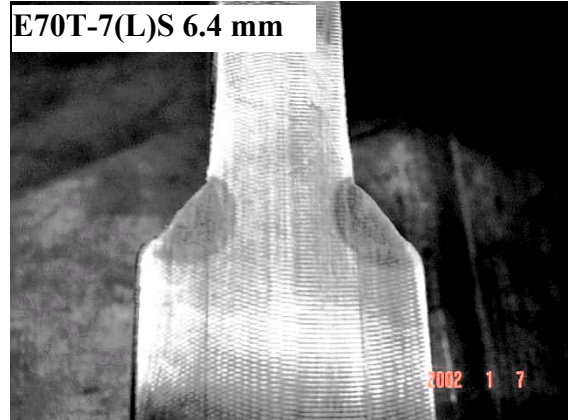

Figure B8 – Specimen T14-1

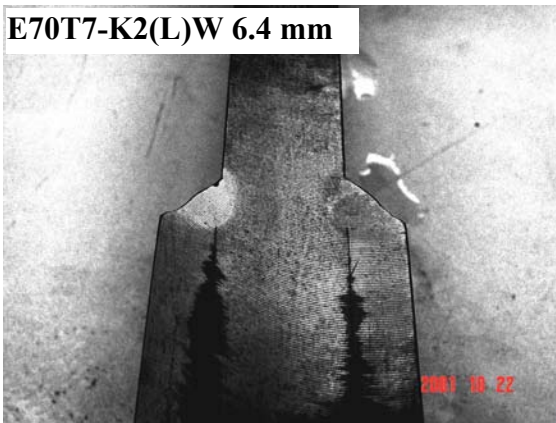

Figure B9 – Specimen T16-2

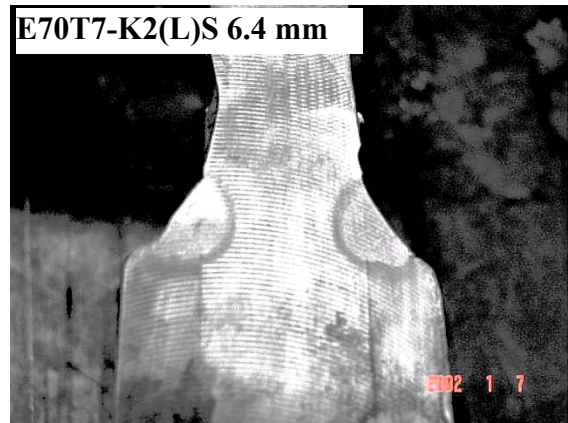

Figure B10 – Specimen T17-1

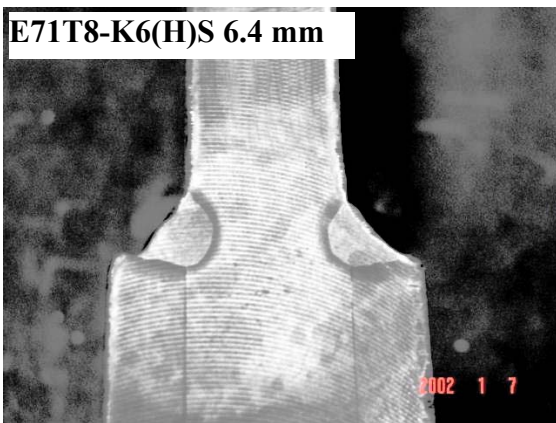

Figure B11 – Specimen T19-1

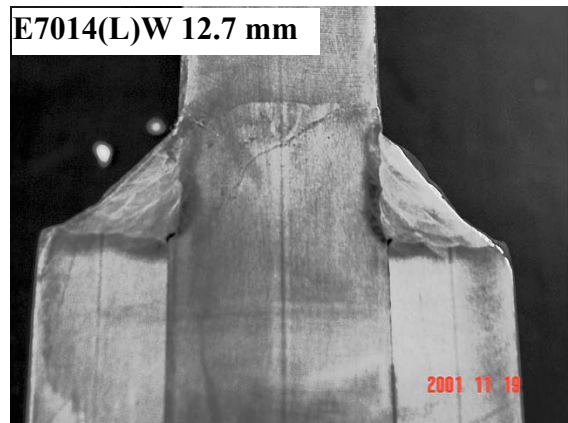

Figure B12 – Specimen T20-1

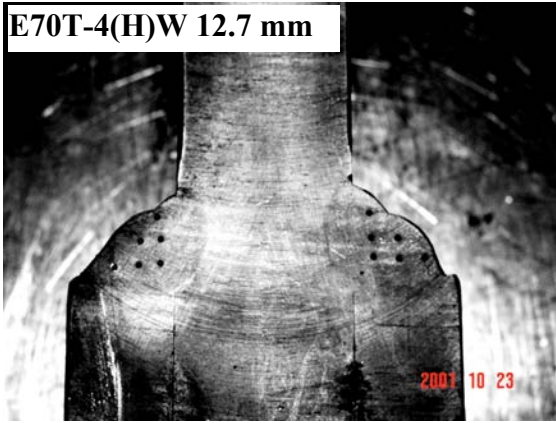

Figure B13 – Specimen T21-1

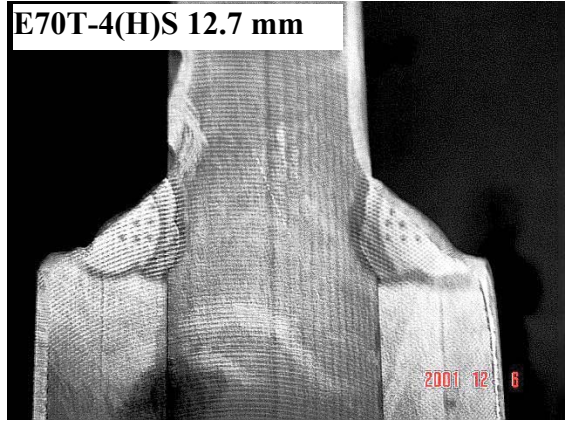

Figure B14 – Specimen T22-2

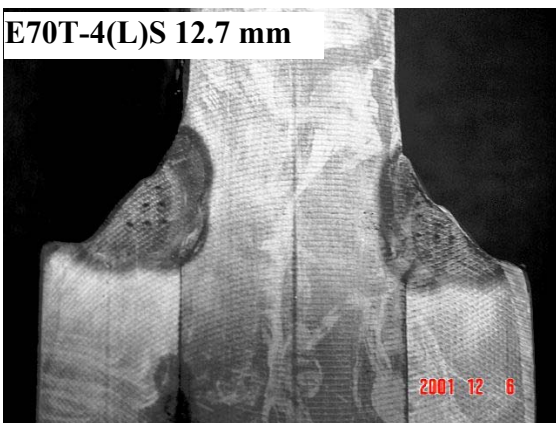

Figure B15 – Specimen T24-3

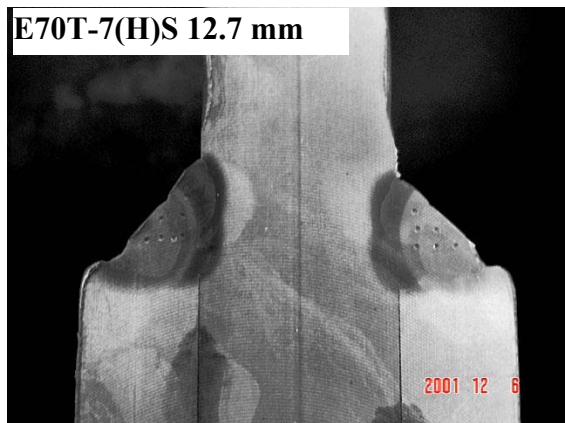

Figure B16 – Specimen T26-1

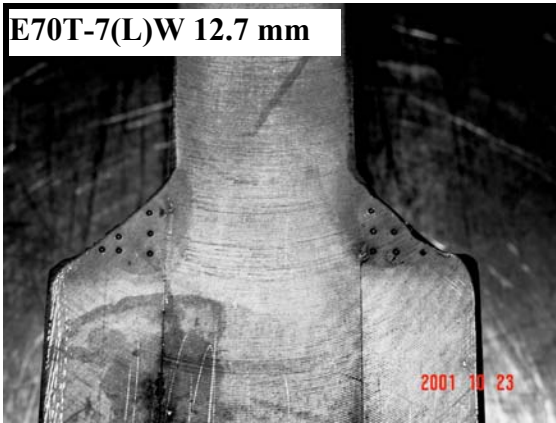

Figure B17 – Specimen T27-2

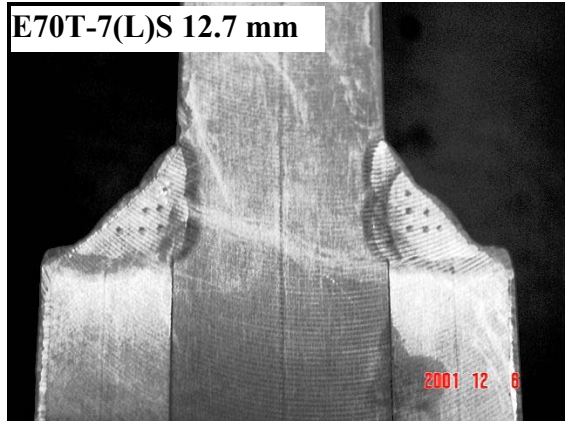

Figure B18 – Specimen T28-3

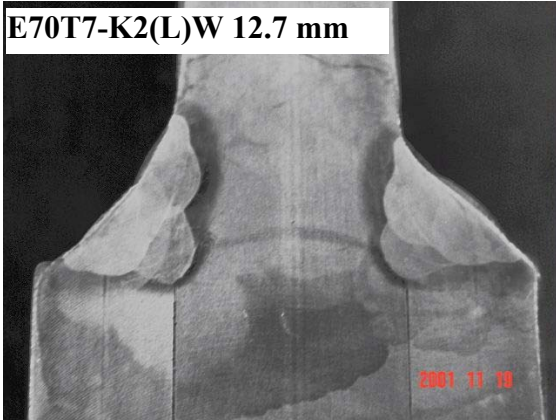

Figure B19 – Specimen T29-2

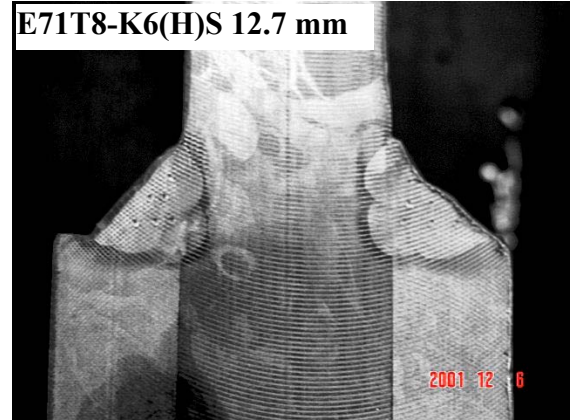

Figure B20 – Specimen T32-2

APPENDIX C

Weld Measurements and Weld Profiles

APPENDIX C – WELD MEASUREMENTS AND WELD PROFILES

This appendix contains the fillet weld measurements, including the gauge lengths for strain measurements, plots of the weld profiles, and also the out-of-straightness measurements for the cruciform specimens.

Eight tension and shear weld leg measurements were made spaced at 10 mm intervals along the weld length. Measurements of the weld profile, oriented at an angle of 45° to the main plate, were also performed at these same locations. For the 12.7 mm welds, 45° measurements were made at three different points at each location in order to better characterize the profile. The locations of these points are shown in Figure C0a.

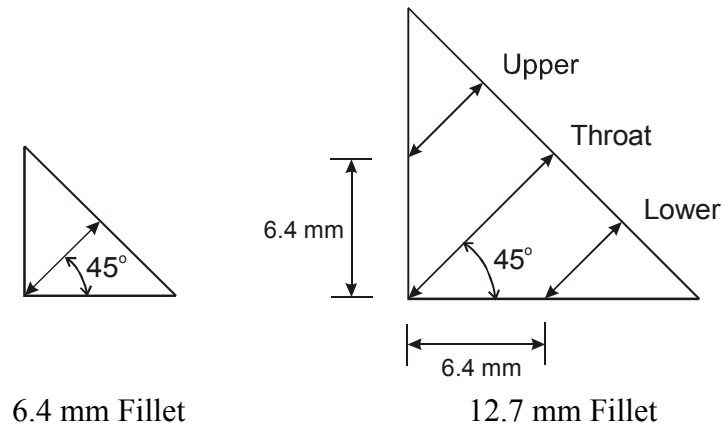

Figure C0a – Pre-test Fillet Weld Measurements

After weld fracture, measurements of the fracture surface, fracture surface angle, and again, the shear leg (called Shear Leg After Fracture in the tables) were made. The Fracture Surface and Shear Leg After Fracture measurements are depicted in Figure C0b.

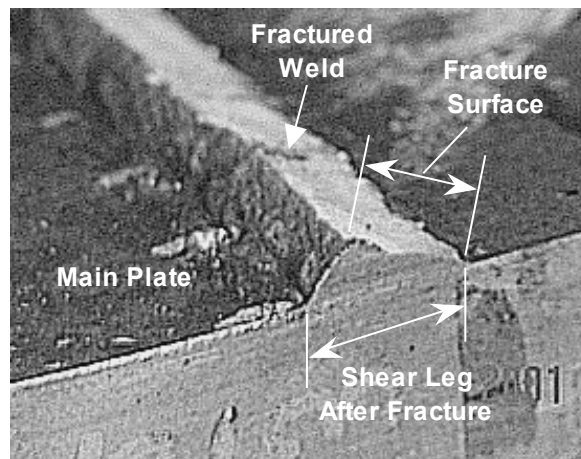

Figure C0b – Shear Leg After Fracture and Fracture Surface Measurements

The Weld Root Penetration values are the difference between the Shear Leg measurement and the Shear Leg After Fracture measurement.

Table C1 – Weld Measurements for Specimen T1-1 (E7014(L)W 6.4 mm)

Meas. Number	Before Failure						After Failure					
	Front Face			Back Face			Failure Face			Failure Face		
	Shear Leg (mm)	Tension Leg (mm)	45° Meas. (mm)	Weld Length (mm)	Shear Leg (mm)	Tension Leg (mm)	45° Meas. (mm)	Weld Length (mm)	Shear Leg After Fracture (mm)	Fracture Surface (mm)	Weld Root Penetration (mm)	Fracture Angle (°)
1	6.1	7.2	5.7	76.0	5.6	6.2	5.2	76.3	6.5	6.5	0.5	0
2	7.0	7.0	5.9	76.0	5.8	6.3	5.9	76.2	7.1	4.6	0.1	15
3	6.5	6.9	5.2	76.0	5.5	6.4	5.6	76.2	6.9	4.3	0.4	19
4	7.1	7.5	6.5	76.0	5.6	6.1	5.1	76.2	7.4	5.4	0.3	13
5	6.2	6.7	6.0	76.0	6.1	5.8	5.1	76.3	6.9	5.4	0.7	2
6	6.4	6.7	5.6	76.0	5.6	6.3	4.9	76.3	7.1	5.3	0.7	15
7	6.3	5.5	5.2	76.0	6.1	6.5	5.2	76.3	6.8	4.7	0.5	16
8	6.6	5.6	5.1	76.0	5.5	6.5	4.9	76.3	6.8	4.6	0.2	16
Mean	6.5	6.6	5.7	76.0	5.7	6.3	5.2	76.2	6.9	5.1	0.4	12

Table C2 – Weld Measurements for Specimen T1-2 (E7014(L)W 6.4 mm)

Meas. Number	Before Failure						After Failure						
	Front Face			Back Face			Front Failure Face			Back Failure Face			
	Shear Leg (mm)	Tension Leg (mm)	45° Meas. (mm)	Weld Length (mm)	Shear Leg (mm)	Tension Leg (mm)	45° Meas. (mm)	Weld Length (mm)	Shear Leg After Fracture (mm)	Fracture Surface (mm)	Weld Root Penetration (mm)	Fracture Angle (°)	
1	6.3	5.9	5.2	76.1	6.4	6.1	5.6	76.1	7.0	4.7	0.7	19	
2	6.7	6.1	5.7	76.2	6.4	5.8	5.2	76.2	7.4	5.2	0.8	19	
3	7.1	6.0	5.4	76.0	6.5	5.5	4.6	76.2	7.6	4.8	0.6	20	
4	7.3	6.1	5.9	76.1	6.7	5.5	5.2	76.2	7.9	5.0	0.6	15	
5	6.6	6.3	5.6	76.0	6.4	6.0	5.7	76.2	6.7	6.1	0.1	0	
6	5.8	6.4	4.9	76.0	5.2	6.0	5.1	76.2	6.1	4.5	0.4	12	
7	6.4	6.6	5.4	76.1	5.9	6.5	5.4	76.2	6.8	4.8	0.4	13	
8	6.1	6.3	5.6	76.1	5.8	6.2	5.6	76.2	7.0	5.2	0.9	11	
Mean	6.5	6.2	5.5	76.1	6.2	5.9	5.3	76.2	7.1	5.0	0.5	14	
													5.42
													0.76
													8.49

Table C3 – Weld Measurements for Specimen T1-3 (E7014(L)W 6.4 mm)

Meas. Number	Before Failure						After Failure								
	Front Face			Back Face			Front Failure Face			Back Failure Face					
	Shear Leg (mm)	Tension Leg (mm)	45° Meas. (mm)	Weld Length (mm)	Shear Leg (mm)	Tension Leg (mm)	45° Meas. (mm)	Weld Length (mm)	Shear Leg After Fracture (mm)	Fracture Surface (mm)	Weld Root Penetration (mm)	Fracture Angle (°)	Weld Root Penetration (mm)	Fracture Surface (mm)	Fracture Angle (°)
1	5.9	5.9	5.2	76.2	5.8	7.0	5.4	76.0	6.8	4.9	0.8	9	6.46	6.46	0.00
2	6.3	6.5	5.4	76.2	6.1	6.8	5.4	76.0	7.1	5.1	0.8	15	6.87	6.25	0.00
3	6.0	6.3	5.1	76.2	5.7	6.6	4.8	76.0	6.5	4.8	0.5	14	6.41	4.41	13.00
4	5.9	6.2	5.1	76.2	5.9	6.4	4.8	76.0	6.6	4.7	0.7	14	6.72	4.91	14.25
5	5.8	6.7	4.6	76.2	5.9	6.9	5.1	76.0	6.7	4.5	0.9	12	6.87	5.01	15.75
6	6.2	6.7	4.8	76.2	6.4	6.5	5.2	76.0	6.7	4.8	0.5	15	7.50	6.40	5.00
7	6.0	7.0	4.9	76.2	6.1	6.6	4.4	76.0	6.7	5.3	0.7	10	6.94	4.53	19.25
8	6.1	7.1	5.2	76.2	6.5	6.3	5.4	76.0	6.7	5.8	0.7	9	7.03	5.89	12.00
Mean	6.0	6.5	5.0	76.2	6.0	6.6	5.1	76.0	6.7	5.0	0.7	12	6.85	5.48	9.91

Table C4 – Weld Measurements for Specimen T2-1 (E7014(L)W 6.4 mm)

Meas. Number	Before Failure						After Failure								
	Front Face			Back Face			Front Failure Face			Back Failure Face					
	Shear Leg (mm)	Tension Leg (mm)	45° Meas. (mm)	Weld Length (mm)	Shear Leg (mm)	Tension Leg (mm)	45° Meas. (mm)	Weld Length (mm)	Shear Leg After Fracture (mm)	Fracture Surface (mm)	Weld Root Penetration (mm)	Fracture Angle (°)	Weld Root Penetration (mm)	Fracture Surface (mm)	Fracture Angle (°)
1	5.4	5.9	3.7	76.2	6.4	6.0	4.4	76.2	6.0	6.0	6.0	3.6	0.7	3.6	14
2	5.4	6.0	4.0	76.2	6.3	6.0	4.3	76.2	6.1	6.0	6.1	3.7	0.8	3.7	8
3	5.5	6.5	4.3	76.2	6.7	6.5	4.6	76.2	6.3	6.5	6.3	4.8	0.7	4.8	5
4	5.3	6.0	4.0	76.2	6.8	6.2	4.4	76.1	6.9	6.2	6.9	4.3	1.7	4.3	7
5	5.6	6.3	4.1	76.2	6.6	5.8	4.3	76.2	6.4	6.4	6.4	4.1	0.9	4.1	11
6	5.4	5.9	4.0	76.2	6.7	6.3	4.3	76.2	6.3	6.3	6.3	4.0	0.9	4.0	7
7	5.7	6.3	4.3	76.2	6.6	6.0	4.3	76.2	6.7	6.7	6.7	4.6	1.0	4.6	9
8	6.1	6.7	4.3	76.2	6.7	5.9	4.3	76.2	6.7	7.2	7.2	4.7	1.1	4.7	12
Mean	5.5	6.2	4.1	76.2	6.6	6.1	4.4	76.2	6.5	6.5	6.5	4.2	1.0	4.2	9

Table C5 – Weld Measurements for Specimen T2-2 (E7014(L)W 6.4 mm)

Meas. Number	Before Failure						After Failure					
	Front Face			Back Face			Front Face			Back Face		
	Shear Leg (mm)	Tension Leg (mm)	45° Meas. (mm)	Weld Length (mm)	Shear Leg (mm)	Tension Leg (mm)	45° Meas. (mm)	Weld Length (mm)	Shear Leg After Fracture (mm)	Fracture Surface (mm)	Weld Root Penetration (mm)	Fracture Angle (°)
1	5.7	5.7	3.8	76.1	6.2	6.0	4.1	76.1	7.1	3.9	1.4	18
2	5.7	5.8	4.1	76.2	6.2	5.9	4.1	76.2	7.2	3.9	1.5	19
3	5.8	6.7	4.4	76.2	6.4	6.1	4.3	76.1	6.0	3.8	0.3	17
4	5.9	5.8	4.3	76.1	6.1	6.1	4.4	76.2	6.9	4.1	1.1	14
5	6.5	6.4	4.6	76.2	6.5	6.9	4.6	76.2	7.4	4.5	0.9	8
6	6.5	6.2	4.6	76.2	6.2	5.9	4.3	76.2	6.8	4.4	0.4	12
7	6.1	5.9	4.4	76.1	5.7	6.3	4.3	76.1	7.0	3.9	1.0	17
8	6.0	6.0	4.6	76.1	5.8	6.4	4.3	76.1	7.5	5.0	1.5	9
Mean	6.0	6.1	4.4	76.1	6.1	6.2	4.3	76.2	7.0	4.2	1.0	14

Table C6 – Weld Measurements for Specimen T2-3 (E7014(L)W 6.4 mm)

Meas. Number	Before Failure						After Failure					
	Front Face			Back Face			Front Face			Back Face		
	Shear Leg (mm)	Tension Leg (mm)	45° Meas. (mm)	Weld Length (mm)	Shear Leg (mm)	Tension Leg (mm)	45° Meas. (mm)	Weld Length (mm)	Shear Leg After Fracture (mm)	Fracture Surface (mm)	Weld Root Penetration (mm)	Fracture Angle (°)
1	5.9	6.1	4.4	76.0	6.1	5.7	4.4	76.2	6.9	4.6	1.1	15
2	6.0	6.7	4.4	76.1	6.2	6.2	4.6	76.2	6.8	5.2	0.8	6
3	5.9	6.6	4.6	76.1	6.3	5.5	4.4	76.1	7.1	5.1	1.2	4
4	5.8	6.5	4.6	76.2	6.2	5.8	4.8	76.2	7.0	4.9	1.2	9
5	6.1	6.9	4.9	76.1	6.4	5.6	4.4	76.2	7.4	4.8	1.3	7
6	6.1	6.9	4.9	76.1	6.3	5.9	4.6	76.2	7.1	5.2	1.0	4
7	6.5	6.9	4.9	76.1	6.4	5.6	4.4	76.2	7.3	4.2	0.8	15
8	6.6	7.2	5.1	76.1	7.0	6.0	4.8	76.2	7.2	4.9	0.6	13
Mean	6.1	6.7	4.7	76.1	6.4	5.8	4.6	76.2	7.1	4.9	1.0	9

Table C7 – Weld Measurements for Specimen T3-1 (E7014(L)W 6.4 mm)

Meas. Number	Before Failure						After Failure					
	Front Face			Back Face			Front Face			Back Face		
	Shear Leg (mm)	Tension Leg (mm)	45° Meas. (mm)	Weld Length (mm)	Shear Leg (mm)	Tension Leg (mm)	45° Meas. (mm)	Weld Length (mm)	Shear Leg After Fracture (mm)	Fracture Surface (mm)	Weld Root Penetration (mm)	Fracture Angle (°)
1	6.6	6.8	5.2	76.0	7.9	7.8	5.2	76.1	6.7	4.7	0.1	11
2	6.8	6.3	4.9	76.0	8.1	8.3	5.2	76.1	6.9	4.5	0.1	16
3	7.5	7.2	5.2	76.0	7.6	6.5	5.1	76.1	7.8	4.6	0.3	18
4	7.4	6.6	5.2	76.1	7.9	6.6	5.1	76.1	7.6	4.5	0.2	13
5	7.4	6.6	5.6	76.1	7.9	7.7	5.2	76.1	7.4	4.7	0.0	14
6	8.0	6.5	5.7	76.1	7.5	7.5	5.4	76.1	8.0	4.9	0.0	21
7	7.8	6.1	5.4	76.1	8.1	7.9	5.4	76.1	7.8	4.7	0.0	17
8	8.2	6.9	5.9	76.1	7.8	7.1	5.2	76.1	8.2	5.2	0.0	12
Mean	7.5	6.6	5.4	76.0	7.9	7.4	5.2	76.1	7.5	4.7	0.1	15

Table C8 – Weld Measurements for Specimen T3-2 (E7014(L)W 6.4 mm)

Meas. Number	Before Failure						After Failure					
	Front Face			Back Face			Front Face			Back Face		
	Shear Leg (mm)	Tension Leg (mm)	45° Meas. (mm)	Weld Length (mm)	Shear Leg (mm)	Tension Leg (mm)	45° Meas. (mm)	Weld Length (mm)	Shear Leg After Fracture (mm)	Fracture Surface (mm)	Weld Root Penetration (mm)	Fracture Angle (°)
1	8.3	6.4	5.2	76.0	8.8	6.7	5.1	76.0	8.5	4.8	0.3	21
2	8.3	7.0	5.4	76.1	8.2	6.6	5.1	76.0	8.3	4.7	0.1	19
3	7.9	7.0	5.4	76.1	8.6	7.8	5.6	76.0	8.0	4.9	0.1	10
4	7.8	6.9	5.6	76.1	8.4	6.8	6.2	76.0	7.9	3.7	0.0	15
5	8.6	7.1	6.0	76.0	7.5	7.2	5.1	76.0	8.2	3.3	-0.4	34
6	7.9	6.3	5.1	76.0	7.9	7.1	5.2	76.0	7.9	4.4	0.0	12
7	7.9	6.8	5.2	76.0	7.9	7.0	4.9	76.0	8.0	4.7	0.1	14
8	7.7	7.2	5.4	76.0	8.5	8.5	5.4	76.0	7.9	5.1	0.1	15
Mean	8.0	6.8	5.4	76.1	8.2	7.2	5.3	76.0	8.1	4.4	0.0	18

Table C9 – Weld Measurements for Specimen T3-3 (E7014(L)W 6.4 mm)

Meas. Number	Before Failure						After Failure					
	Front Face			Back Face			Failure Face			Failure Face		
	Shear Leg (mm)	Tension Leg (mm)	45° Meas. (mm)	Weld Length (mm)	Shear Leg (mm)	Tension Leg (mm)	45° Meas. (mm)	Weld Length (mm)	Shear Leg After Fracture (mm)	Fracture Surface (mm)	Weld Root Penetration (mm)	Fracture Angle (°)
1	7.9	7.0	5.6	76.0	8.0	7.6	5.6	75.9	7.8	5.3	-0.2	14
2	7.3	7.1	5.2	76.0	8.0	7.6	5.6	76.0	7.3	5.0	0.0	8
3	7.3	7.1	5.2	76.0	7.6	7.0	5.4	76.0	7.4	4.4	0.0	13
4	7.7	7.1	5.4	76.1	7.7	7.0	5.1	75.9	7.4	5.2	-0.3	11
5	7.6	7.2	5.4	76.1	7.6	6.4	5.1	76.0	7.5	5.0	-0.2	14
6	7.8	7.5	5.4		8.4	6.6	5.4		7.7	5.0	-0.1	12
7	7.7	7.5	5.6		7.9	6.5	5.2		7.9	5.1	0.1	9
8	7.6	7.4	5.6		7.9	6.7	5.2		7.7	4.6	0.1	10
Mean	7.6	7.3	5.4	76.0	7.9	6.9	5.3	76.0	7.6	4.9	-0.1	12

Table C10 – Weld Measurements for Specimen T4-1 (E70T-4(H)W 6.4 mm)

Meas. Number	Before Failure						After Failure					
	Front Face			Back Face			Failure Face			Failure Face		
	Shear Leg (mm)	Tension Leg (mm)	45° Meas. (mm)	Weld Length (mm)	Shear Leg (mm)	Tension Leg (mm)	45° Meas. (mm)	Weld Length (mm)	Shear Leg After Fracture (mm)	Fracture Surface (mm)	Weld Root Penetration (mm)	Fracture Angle (°)
1	5.8	6.6	5.6	76.1	6.1	6.1	5.4	76.1	8.0	8.0	1.9	0
2	6.0	6.5	5.6	76.2	5.7	5.6	5.2	76.1	8.7	8.7	3.1	0
3	5.9	6.2	5.4	76.2	6.3	6.3	5.4	76.1	9.0	9.0	2.6	0
4	5.6	5.6	5.2	76.2	5.8	6.6	5.6	76.1	7.9	7.9	2.1	0
5	6.2	6.5	5.6	76.2	6.6	5.8	5.6	76.1	9.3	9.3	2.7	0
6	6.4	6.3	5.2		6.3	6.3	5.6		8.4	8.4	2.1	0
7	5.4	6.0	5.4		5.9	5.8	5.6		8.6	8.6	2.7	0
8	5.7	6.1	5.6		6.3	6.2	5.7		8.6	8.6	2.3	0
Mean	5.9	6.2	5.4	76.2	6.1	6.1	5.5	76.1	8.6	8.6	2.4	0

Table C11 – Weld Measurements for Specimen T4-2 (E70T-4(H)W 6.4 mm)

Meas. Number	Before Failure						After Failure					
	Front Face			Back Face			Failure Face			Failure Face		
	Shear Leg (mm)	Tension Leg (mm)	45° Meas. (mm)	Weld Length (mm)	Shear Leg (mm)	Tension Leg (mm)	45° Meas. (mm)	Weld Length (mm)	Shear Leg After Fracture (mm)	Fracture Surface (mm)	Weld Root Penetration (mm)	Fracture Angle (°)
1	6.0	6.6	5.4	76.1	5.7	6.4	5.6	76.0	8.4	8.4	2.7	0
2	6.2	6.3	5.4	76.2	6.3	6.0	5.6	76.1	8.9	8.9	2.6	0
3	5.8	6.1	5.4	76.2	6.9	5.7	5.7	76.1	9.5	9.5	2.6	0
4	6.4	6.3	5.4	76.2	6.6	6.1	5.6	76.1	9.1	9.1	2.5	0
5	6.3	6.5	5.4	76.1	6.4	5.8	5.6	76.1	8.8	8.8	2.4	0
6	6.7	6.1	5.4	76.1	6.3	5.6	5.4	76.1	9.0	9.0	2.7	0
7	5.6	6.7	5.2	76.1	6.1	6.5	5.6	76.1	9.5	9.5	3.4	0
8	6.1	6.7	5.6	76.1	6.2	6.8	5.7	76.1	8.2	8.2	1.9	0
Mean	6.1	6.4	5.4	76.1	6.3	6.1	5.6	76.1	8.9	8.9	2.6	0

Table C12 – Weld Measurements for Specimen T4-3 (E70T-4(H)W 6.4 mm)

Meas. Number	Before Failure						After Failure					
	Front Face			Back Face			Failure Face			Failure Face		
	Shear Leg (mm)	Tension Leg (mm)	45° Meas. (mm)	Weld Length (mm)	Shear Leg (mm)	Tension Leg (mm)	45° Meas. (mm)	Weld Length (mm)	Shear Leg After Fracture (mm)	Fracture Surface (mm)	Weld Root Penetration (mm)	Fracture Angle (°)
1	6.2	6.4	5.4	76.1	6.3	5.8	5.4	76.1	9.0	9.0	2.7	0
2	6.1	6.4	5.2	76.1	6.0	5.8	5.4	76.1	8.5	8.5	2.4	0
3	5.9	6.2	5.1	76.1	6.0	6.0	5.4	76.0	8.8	8.8	2.7	0
4	5.9	6.3	5.2	76.1	6.3	5.4	5.4	76.1	9.5	9.5	3.2	0
5	5.7	6.1	5.1	76.1	5.8	6.4	5.6	76.0	8.2	8.2	2.4	0
6	5.9	6.3	5.2	76.1	6.4	6.2	5.7	76.0	8.4	8.4	2.1	0
7	6.2	6.4	5.2	76.1	5.8	5.6	5.6	76.0	8.9	8.9	3.1	0
8	5.9	6.2	5.2	76.1	5.7	6.7	5.4	76.1	8.6	8.6	2.9	0
Mean	6.0	6.3	5.2	76.1	6.0	6.0	5.5	76.1	8.7	8.7	2.7	0

Table C13 – Weld Measurements for Specimen T5-1 (E70T-4(H)W 6.4 mm)

Meas. Number	Before Failure						After Failure					
	Front Face			Back Face			Failure Face			Failure Face		
	Shear Leg (mm)	Tension Leg (mm)	45° Meas. (mm)	Weld Length (mm)	Shear Leg (mm)	Tension Leg (mm)	45° Meas. (mm)	Weld Length (mm)	Shear Leg After Fracture (mm)	Fracture Surface (mm)	Weld Root Penetration (mm)	Fracture Angle (°)
1	6.2	5.7	4.6	76.0	5.7	5.9	4.8	76.0	8.2	8.2	2.4	0
2	6.7	5.9	4.9	76.1	5.8	6.7	4.9	76.0	8.7	8.7	2.9	0
3	6.4	5.8	4.8	76.1	6.4	5.7	5.1	76.1	8.9	8.9	2.5	0
4	7.0	5.9	4.9	76.1	5.8	6.1	5.1	76.0	8.5	8.5	2.7	0
5	6.6	5.9	4.8	76.1	6.5	5.8	5.1	76.0	8.9	8.9	2.4	0
6	5.5	5.6	4.6		5.6	5.9	5.1		7.9	7.9	2.3	0
7	6.3	5.6	4.8		6.5	6.3	5.2		8.8	8.8	2.4	0
8	6.6	5.9	4.9		5.7	6.4	4.9		7.8	7.8	2.0	0
Mean	6.4	5.8	4.8	76.1	6.0	6.1	5.0	76.0	8.5	8.5	2.5	0

Table C14 – Weld Measurements for Specimen T5-2 (E70T-4(H)W 6.4 mm)

Meas. Number	Before Failure						After Failure					
	Front Face			Back Face			Failure Face			Failure Face		
	Shear Leg (mm)	Tension Leg (mm)	45° Meas. (mm)	Weld Length (mm)	Shear Leg (mm)	Tension Leg (mm)	45° Meas. (mm)	Weld Length (mm)	Shear Leg After Fracture (mm)	Fracture Surface (mm)	Weld Root Penetration (mm)	Fracture Angle (°)
1	6.8	6.1	4.8	75.9	6.2	5.8	4.8	76.0	9.6	9.6	3.4	0
2	6.2	5.5	4.8	75.9	6.1	5.6	4.9	76.0	9.9	9.9	3.8	0
3	6.2	5.7	4.8	75.9	6.0	5.8	4.9	76.0	9.3	9.3	3.3	0
4	6.6	5.6	4.8	75.9	6.7	6.7	5.1	75.9	10.1	10.1	3.5	0
5	6.6	5.8	5.1	75.9	6.0	5.7	4.9	75.9	9.3	9.3	3.3	0
6	6.0	5.7	4.8		6.9	6.7	5.2		10.1	10.1	3.2	0
7	6.9	5.9	5.1		6.4	6.2	5.2		9.5	9.5	3.1	0
8	6.6	5.7	5.1		6.2	6.8	4.9		9.8	9.8	3.7	0
Mean	6.5	5.8	4.9	75.9	6.3	6.2	5.0	76.0	9.7	9.7	3.4	0

Table C15 – Weld Measurements for Specimen T5-3 (E70T-4(H)W 6.4 mm)

Meas. Number	Before Failure						After Failure					
	Front Face			Back Face			Front Face			Back Face		
	Shear Leg (mm)	Tension Leg (mm)	45° Meas. (mm)	Weld Length (mm)	Shear Leg (mm)	Tension Leg (mm)	45° Meas. (mm)	Weld Length (mm)	Shear Leg After Fracture (mm)	Fracture Surface (mm)	Weld Root Penetration (mm)	Fracture Angle (°)
1	6.2	5.4	4.9	76.0	5.7	6.1	4.6	76.0	9.6	9.6	3.8	0
2	5.7	5.9	4.8	75.9	5.4	5.9	4.4	76.0	9.6	9.6	4.2	0
3	6.6	6.1	4.9	75.9	5.8	6.0	4.6	76.0	8.9	8.9	3.1	0
4	6.2	5.9	4.8	76.0	5.7	5.7	4.9	75.9	9.1	9.1	3.4	0
5	6.3	5.7	4.8	76.0	6.2	5.8	5.1	76.0	9.9	9.9	3.7	0
6	6.4	5.4	4.9	76.0	5.5	6.4	4.8	76.0	9.3	9.3	3.8	0
7	6.4	5.4	5.1	76.0	6.2	5.7	4.8	76.0	9.5	9.5	3.3	0
8	6.8	6.3	5.1	76.0	6.2	5.9	4.8	76.0	9.4	9.4	3.2	0
Mean	6.3	5.8	4.9	75.9	5.8	5.9	4.7	76.0	9.4	9.4	3.6	0

Table C16 – Weld Measurements for Specimen T6-1 (E70T-4(H)W 6.4 mm)

Meas. Number	Before Failure						After Failure					
	Front Face			Back Face			Front Face			Back Face		
	Shear Leg (mm)	Tension Leg (mm)	45° Meas. (mm)	Weld Length (mm)	Shear Leg (mm)	Tension Leg (mm)	45° Meas. (mm)	Weld Length (mm)	Shear Leg After Fracture (mm)	Fracture Surface (mm)	Weld Root Penetration (mm)	Fracture Angle (°)
1	6.6	4.9	4.4	75.9	6.6	5.4	4.6	75.9	9.7	5.2	3.1	90
2	6.4	5.3	4.4	75.9	6.3	5.8	4.6	76.0	9.5	5.8	3.0	90
3	6.4	5.3	4.6	75.9	6.3	5.4	4.6	76.0	9.3	5.4	3.0	90
4	6.9	5.5	4.8	75.9	6.8	5.6	4.8	76.0	10.0	5.7	3.1	90
5	6.9	4.5	4.4	75.9	6.9	5.8	4.8	75.9	9.4	4.6	2.6	90
6	6.4	5.4	4.8	75.9	6.4	5.5	4.8	75.9	9.9	5.7	3.4	90
7	6.6	4.6	4.6	75.9	6.6	5.7	4.8	75.9	9.2	5.0	2.6	90
8	6.4	5.1	4.6	75.9	6.4	5.0	4.6	75.9	9.6	6.2	3.2	90
Mean	6.6	5.1	4.6	75.9	6.5	5.5	4.7	76.0	9.6	5.4	3.0	90

Table C17 – Weld Measurements for Specimen T6-2 (E70T-4(H)W 6.4 mm)

Meas. Number	Before Failure						After Failure					
	Front Face			Back Face			Failure Face			Failure Face		
	Shear Leg (mm)	Tension Leg (mm)	45° Meas. (mm)	Weld Length (mm)	Shear Leg (mm)	Tension Leg (mm)	45° Meas. (mm)	Weld Length (mm)	Shear Leg After Fracture (mm)	Fracture Surface (mm)	Weld Root Penetration (mm)	Fracture Angle (°)
1	6.9	5.6	4.6	76.0	7.0	5.6	4.4	76.0	10.5	5.5	3.5	90
2	6.4	5.2	4.6	76.0	6.7	4.9	4.3	76.0	10.0	5.1	3.4	90
3	6.2	5.6	4.8	76.0	6.6	5.4	4.4	76.0	9.8	5.4	3.1	90
4	6.2	5.8	4.8	76.0	6.5	4.7	4.0	76.0	9.8	4.9	3.3	90
5	6.3	5.5	4.8	76.0	6.8	5.1	4.4	76.0	9.7	5.2	2.9	90
6	6.0	5.9	4.8		7.1	5.4	4.4		10.6	6.0	3.5	33
7	6.5	5.6	4.9		6.8	4.9	4.4		10.1	5.1	3.4	45
8	6.2	6.2	4.8		6.2	4.9	4.4		9.8	5.6	3.6	90
Mean	6.3	5.7	4.7	76.0	6.7	5.1	4.4	76.0	10.0	5.3	3.3	77

Table C18 – Weld Measurements for Specimen T6-3 (E70T-4(H)W 6.4 mm)

Meas. Number	Before Failure						After Failure					
	Front Face			Back Face			Failure Face			Failure Face		
	Shear Leg (mm)	Tension Leg (mm)	45° Meas. (mm)	Weld Length (mm)	Shear Leg (mm)	Tension Leg (mm)	45° Meas. (mm)	Weld Length (mm)	Shear Leg After Fracture (mm)	Fracture Surface (mm)	Weld Root Penetration (mm)	Fracture Angle (°)
1	7.1	5.8	4.8	75.9	7.1	6.1	4.8	76.0	10.2	6.1	3.2	90
2	7.1	5.8	4.8	75.8	6.1	5.5	4.3	76.0	9.1	5.7	3.1	90
3	6.6	6.1	4.8	75.9	6.7	5.7	4.4	76.0	10.0	5.7	3.3	90
4	6.1	6.3	4.8	75.9	6.5	5.4	4.4	76.0	9.7	5.4	3.3	90
5	6.9	5.7	4.6	75.9	6.4	5.4	4.4	76.0	9.6	6.1	3.1	90
6	6.0	6.0	4.6		6.6	5.0	4.4		10.0	5.5	3.4	90
7	6.4	5.4	4.8		6.7	4.6	4.4		9.9	5.3	3.2	90
8	6.0	5.5	5.1		6.1	5.6	4.4		10.0	5.9	3.9	90
Mean	6.5	5.8	4.8	75.9	6.5	5.4	4.5	76.0	9.8	5.7	3.3	90

Table C19 – Weld Measurements for Specimen T7-1 (E70T-4(H)S 6.4 mm)

Meas. Number	Before Failure						After Failure									
	Front Face			Back Face			Front Failure Face			Back Failure Face						
	Shear Leg (mm)	Tension Leg (mm)	45° Meas. (mm)	Weld Length (mm)	Shear Leg (mm)	Tension Leg (mm)	45° Meas. (mm)	Weld Length (mm)	Shear Leg After Fracture (mm)	Fracture Surface (mm)	Weld Root Penetration (mm)	Fracture Angle (°)	Shear Leg After Fracture (mm)	Fracture Surface (mm)	Weld Root Penetration (mm)	Fracture Angle (°)
1	4.0	4.8	4.0	76.1	6.6	4.6	4.3	76.0	9.0	5.1	5.1	90	7.7	4.9	1.2	90
2	4.7	5.3	4.4	76.1	7.5	5.2	4.6	76.0	9.6	5.7	4.8	90	8.5	4.9	1.0	90
3	5.2	4.8	4.4	76.1	7.4	3.6	4.4	76.0	9.3	5.5	4.1	90	9.3	4.0	1.9	90
4	6.9	5.6	4.6	76.1	6.7	4.1	4.8	76.0	8.6	6.1	1.7	90	10.3	4.3	3.6	90
5	6.0	5.6	4.6	76.1	5.2	6.2	5.2	76.0	7.4	6.0	1.4	90	9.6	6.3	4.4	90
6	4.9	4.9	4.3	76.1	7.5	5.4	5.1	76.0	10.1	5.5	5.2	90	8.6	5.5	1.1	90
7	5.1	5.2	4.4	76.1	6.7	5.5	4.8	76.0	10.0	5.9	5.0	90	9.0	6.0	2.2	90
8	5.5	5.1	4.3	76.1	6.5	5.4	4.8	76.0	8.9	5.6	3.5	90	9.2	5.5	2.8	90
Mean	5.3	5.1	4.4	76.1	6.8	5.0	4.7	76.0	9.1	5.7	3.8	90	9.0	5.2	2.3	90

Table C20 – Weld Measurements for Specimen T7-2 (E70T-4(H)S 6.4 mm)

Meas. Number	Before Failure						After Failure									
	Front Face			Back Face			Front Failure Face			Back Failure Face						
	Shear Leg (mm)	Tension Leg (mm)	45° Meas. (mm)	Weld Length (mm)	Shear Leg (mm)	Tension Leg (mm)	45° Meas. (mm)	Weld Length (mm)	Shear Leg After Fracture (mm)	Fracture Surface (mm)	Weld Root Penetration (mm)	Fracture Angle (°)	Shear Leg After Fracture (mm)	Fracture Surface (mm)	Weld Root Penetration (mm)	Fracture Angle (°)
1	5.3	4.2	3.7	76.2	5.9	4.8	4.0	76.1	7.5	7.5	2.2	0	9.2	5.2	3.2	90
2	4.3	5.1	3.7	76.2	5.4	3.7	3.8	76.1	7.3	7.3	3.0	0	8.5	4.3	3.1	90
3	4.5	4.9	4.0	76.3	5.6	4.8	4.2	76.1	7.5	7.5	3.0	0	8.3	5.3	2.6	90
4	4.5	4.6	4.0	76.1	5.8	4.2	4.1	76.1	7.5	4.9	3.0	90	8.3	4.4	2.5	90
5	5.4	4.3	4.1	76.1	5.9	4.0	4.1	76.1	8.4	4.6	3.0	90	8.1	4.1	2.3	90
6	5.8	3.6	4.0	76.1	7.0	4.8	4.2	76.1	8.1	3.5	2.3	90	9.3	4.7	2.3	90
7	6.1	5.0	4.3	76.1	6.0	4.2	3.8	76.1	8.2	5.1	2.1	90	7.8	4.0	1.8	90
8	5.1	4.6	3.8	76.2	5.9	4.8	4.0	76.1	8.0	5.0	2.9	90	8.9	5.2	3.1	90
Mean	5.1	4.5	3.9	76.2	5.9	4.4	4.0	76.1	7.8	5.7	2.7	56	8.5	4.7	2.6	90

Table C21 – Weld Measurements for Specimen T7-3 (E70T-4(H)S 6.4 mm)

Meas. Number	Before Failure						After Failure					
	Front Face			Back Face			Failure Face			Failure Face		
	Shear Leg (mm)	Tension Leg (mm)	45° Meas. (mm)	Weld Length (mm)	Shear Leg (mm)	Tension Leg (mm)	45° Meas. (mm)	Weld Length (mm)	Shear Leg After Fracture (mm)	Fracture Surface (mm)	Weld Root Penetration (mm)	Fracture Angle (°)
1	5.3	4.5	4.0	76.1	5.7	5.3	4.6	76.1	-	5.4	-	0
2	5.0	4.3	4.1	76.1	5.7	5.4	4.6	76.1	-	6.7	-	0
3	4.7	4.7	4.3	76.1	5.5	3.9	4.0	76.1	-	6.0	-	0
4	5.2	3.9	4.0	76.0	5.7	4.8	4.3	76.1	-	6.3	-	0
5	5.3	4.7	4.3	76.1	5.7	4.1	4.1	76.1	-	5.9	-	0
6	5.3	4.6	4.1	76.1	5.8	4.0	4.4	76.1	-	5.5	-	0
7	5.3	4.5	4.3	76.1	5.8	5.2	4.6	76.1	-	7.2	-	0
8	5.3	4.7	4.4	76.1	5.0	5.1	4.6	76.1	-	6.9	-	0
Mean	5.2	4.5	4.2	76.1	5.6	4.7	4.4	76.1		6.2		0

Table C22 – Weld Measurements for Specimen T8-1 (E70T-4(L)W 6.4 mm)

Meas. Number	Before Failure						After Failure					
	Front Face			Back Face			Failure Face			Failure Face		
	Shear Leg (mm)	Tension Leg (mm)	45° Meas. (mm)	Weld Length (mm)	Shear Leg (mm)	Tension Leg (mm)	45° Meas. (mm)	Weld Length (mm)	Shear Leg After Fracture (mm)	Fracture Surface (mm)	Weld Root Penetration (mm)	Fracture Angle (°)
1	6.0	7.0	6.0	75.6	6.4	7.4	6.0	75.4				
2	5.8	7.1	5.7	75.7	6.3	7.3	6.0	75.5				
3	5.9	7.2	5.6	75.6	6.8	7.1	6.4	75.4				
4	5.6	7.2	5.6	75.6	7.0	7.3	6.4	75.4				
5	5.4	7.3	5.9	75.7	6.6	8.0	6.2	75.4				
6	5.6	7.3	5.9	75.6	6.6	8.4	6.2	75.4				
7	6.6	7.5	6.0	75.6	6.6	7.6	6.2	75.4				
8	6.0	7.6	6.0	75.6	6.1	7.9	6.5	75.4				
Mean	5.9	7.3	5.8	75.6	6.5	7.6	6.2	75.4				

Table C23 – Weld Measurements for Specimen T8-2 (E70T-4(L)W 6.4 mm)

Meas. Number	Before Failure						After Failure					
	Front Face			Back Face			Failure Face			Fracture Face		
	Shear Leg (mm)	Tension Leg (mm)	45° Meas. (mm)	Weld Length (mm)	Shear Leg (mm)	Tension Leg (mm)	45° Meas. (mm)	Weld Length (mm)	Shear Leg After Fracture (mm)	Fracture Surface (mm)	Weld Root Penetration (mm)	Fracture Angle (°)
1	5.5	7.6	5.6	75.3	6.3	7.1	5.9	75.5	8.7	6.5	2.4	18
2	5.9	7.7	6.2	75.6	6.5	7.1	6.0	75.6	8.4	6.2	2.0	15
3	6.1	8.2	6.0	75.6	7.0	7.5	6.2	75.5	9.3	8.4	2.2	0
4	5.9	7.7	6.0	75.6	7.0	7.4	6.2	75.5	8.3	9.0	1.4	0
5	5.9	7.6	6.2	75.5	7.0	7.7	6.2	75.5	8.6	6.2	1.6	14
6	6.4	7.6	6.4	75.5	6.1	7.2	6.0	75.5	9.1	8.9	3.1	0
7	6.4	7.4	6.2	75.5	6.6	7.0	6.0	75.5	8.7	8.7	2.1	0
8	6.1	7.7	6.2	75.5	5.9	7.2	6.0	75.5	7.7	7.7	1.7	0
Mean	6.0	7.7	6.1	75.5	6.5	7.3	6.1	75.5	8.6	7.7	2.1	6

Table C24 – Weld Measurements for Specimen T8-3 (E70T-4(L)W 6.4 mm)

Meas. Number	Before Failure						After Failure					
	Front Face			Back Face			Failure Face			Fracture Face		
	Shear Leg (mm)	Tension Leg (mm)	45° Meas. (mm)	Weld Length (mm)	Shear Leg (mm)	Tension Leg (mm)	45° Meas. (mm)	Weld Length (mm)	Shear Leg After Fracture (mm)	Fracture Surface (mm)	Weld Root Penetration (mm)	Fracture Angle (°)
1	6.2	7.2	6.0	76.3	7.5	7.5	6.5	76.4	8.6	6.3	2.5	15
2	6.7	7.7	6.2	76.2	7.4	7.2	6.2	76.4	9.1	7.7	2.4	9
3	5.7	7.8	6.0	76.3	6.6	7.1	6.4	76.4	8.4	8.4	2.7	0
4	6.2	8.2	6.2	76.2	6.8	7.0	6.2	76.4	8.6	8.3	2.4	0
5	6.4	7.8	6.2	76.3	6.5	7.1	6.0	76.3	8.2	7.9	1.8	0
6	7.0	7.8	6.0	76.3	7.2	7.0	5.9	76.3	8.9	6.6	1.9	11
7	7.2	7.9	6.4	76.3	6.8	7.0	5.6	76.3	8.6	6.4	1.4	14
8	7.1	8.0	6.4	76.3	6.5	7.2	5.7	76.3	9.2	7.0	2.1	10
Mean	6.5	7.8	6.2	76.3	6.9	7.1	6.1	76.4	8.7	7.3	2.1	7

Table C25 – Weld Measurements for Specimen T9-1 (E70T-4(L)S 6.4 mm)

Meas. Number	Before Failure						After Failure					
	Front Face			Back Face			Failure Face			Failure Face		
	Shear Leg (mm)	Tension Leg (mm)	45° Meas. (mm)	Weld Length (mm)	Shear Leg (mm)	Tension Leg (mm)	45° Meas. (mm)	Weld Length (mm)	Shear Leg After Fracture (mm)	Fracture Surface (mm)	Weld Root Penetration (mm)	Fracture Angle (°)
1	6.8	5.1	4.6	76.0	7.9	5.3	5.2	76.1	10.4	4.9	2.6	90
2	7.4	5.8	5.6	76.0	8.9	5.7	5.6	76.1	10.6	5.4	1.7	60
3	8.1	5.9	5.9	76.0	8.1	6.0	5.4	76.1	9.9	6.0	1.9	27
4	7.8	5.5	5.6	76.1	8.5	6.3	5.4	76.1	10.5	6.8	2.1	20
5	7.1	6.6	6.0	76.1	8.5	6.0	5.4	76.1	9.9	6.9	1.4	15
6	6.4	6.5	5.7	76.1	8.9	6.0	5.9	76.1	9.9	6.8	1.0	18
7	7.5	6.8	5.7	76.1	8.4	5.8	5.6	76.1	9.7	5.9	1.3	16
8	7.9	6.1	5.6	76.1	9.4	5.8	5.6	76.1	11.0	5.3	1.7	75
Mean	7.4	6.0	5.6	76.0	8.6	5.8	5.5	76.1	10.3	6.0	1.7	40

Table C26 – Weld Measurements for Specimen T9-2 (E70T-4(L)S 6.4 mm)

Meas. Number	Before Failure						After Failure					
	Front Face			Back Face			Failure Face			Failure Face		
	Shear Leg (mm)	Tension Leg (mm)	45° Meas. (mm)	Weld Length (mm)	Shear Leg (mm)	Tension Leg (mm)	45° Meas. (mm)	Weld Length (mm)	Shear Leg After Fracture (mm)	Fracture Surface (mm)	Weld Root Penetration (mm)	Fracture Angle (°)
1	8.2	5.8	5.2	76.1	8.1	6.1	5.6	76.0	9.6	6.9	1.5	21
2	8.2	5.3	5.1	76.0	9.0	6.7	5.9	76.0	11.0	8.3	2.0	13
3	7.3	5.6	4.9	76.0	9.0	6.6	5.4	76.1	10.4	7.0	1.4	18
4	8.4	5.0	5.1	76.1	8.2	6.0	5.2	76.1	10.0	8.4	1.9	11
5	7.8	5.1	5.4	76.1	8.1	5.6	5.2	76.0	9.2	6.5	1.1	19
6	9.3	6.7	5.9	76.1	8.4	6.2	5.1	76.0	10.3	6.9	2.0	20
7	8.6	5.9	5.6	76.1	8.3	5.9	5.2	76.0	9.6	6.1	1.3	22
8	8.1	5.7	5.2	76.1	7.6	5.5	4.9	76.0	9.6	4.8	2.0	90
Mean	8.2	5.6	5.3	76.1	8.3	6.1	5.3	76.0	10.0	6.9	1.6	27

Table C27 – Weld Measurements for Specimen T9-3 (E70T-4(L)S 6.4 mm)

Meas. Number	Before Failure						After Failure					
	Front Face			Back Face			Front Face			Back Face		
	Shear Leg (mm)	Tension Leg (mm)	45° Meas. (mm)	Weld Length (mm)	Shear Leg (mm)	Tension Leg (mm)	45° Meas. (mm)	Weld Length (mm)	Shear Leg After Fracture (mm)	Fracture Surface (mm)	Weld Root Penetration (mm)	Fracture Angle (°)
1	8.6	5.8	5.7	76.0	8.3	5.8	5.7	76.0	10.4	5.8	1.8	33
2	7.3	5.0	5.4	76.0	7.6	6.0	5.6	76.0	8.6	5.1	1.3	35
3	8.7	5.9	5.9	76.0	8.1	6.4	5.6	76.0	10.5	6.4	1.9	27
4	9.0	6.2	6.0	76.0	8.3	6.8	5.4	76.0	10.2	6.9	1.3	23
5	9.1	6.6	6.2	76.0	7.6	5.5	5.4	76.0	10.4	7.1	1.3	21
6	8.0	6.1	6.0	76.0	8.2	5.5	5.6	76.0	10.5	7.5	2.5	20
7	7.9	6.3	6.2	76.0	7.8	6.6	5.7	76.0	9.9	7.0	2.1	23
8	8.2	6.7	6.2	76.0	8.3	6.5	5.7	76.0	9.7	6.6	1.5	21
Mean	8.3	6.1	6.0	76.0	8.0	6.1	5.6	76.0	10.0	6.5	1.7	25

Table C28 – Weld Measurements for Specimen T10-1 (E70T-4(L)S 6.4 mm)

Meas. Number	Before Failure						After Failure					
	Front Face			Back Face			Front Face			Back Face		
	Shear Leg (mm)	Tension Leg (mm)	45° Meas. (mm)	Weld Length (mm)	Shear Leg (mm)	Tension Leg (mm)	45° Meas. (mm)	Weld Length (mm)	Shear Leg After Fracture (mm)	Fracture Surface (mm)	Weld Root Penetration (mm)	Fracture Angle (°)
1	9.4	6.7	6.2	76.0	8.5	6.2	6.2	76.1	9.4	6.4	0.0	49
2	7.0	6.0	5.7	76.0	8.3	7.4	6.5	76.0	8.6	5.6	1.6	47
3	7.8	6.6	6.0	76.0	9.6	6.5	6.5	76.0	8.7	6.0	0.9	42
4	7.7	6.9	6.2	76.0	9.0	6.1	6.4	76.1	8.6	6.1	0.9	26
5	7.2	6.7	5.7	76.0	8.9	6.8	6.5	76.0	8.4	8.0	1.2	0
6	7.8	6.9	5.9	76.0	8.6	6.4	6.7	76.0	9.6	6.5	1.8	15
7	6.8	6.1	5.6	76.0	8.5	6.7	6.8	76.0	8.2	7.3	1.4	0
8	8.2	6.9	5.7	76.0	8.8	6.5	6.4	76.1	9.9	6.9	1.7	8
Mean	7.7	6.6	5.9	76.0	8.8	6.6	6.5	76.1	8.9	6.6	1.2	23

Table C29 – Weld Measurements for Specimen T10-2 (E70T-4(L)S 6.4 mm)

Meas. Number	Before Failure						After Failure					
	Front Face			Back Face			Failure Face			Failure Face		
	Shear Leg (mm)	Tension Leg (mm)	45° Meas. (mm)	Weld Length (mm)	Shear Leg (mm)	Tension Leg (mm)	45° Meas. (mm)	Weld Length (mm)	Shear Leg After Fracture (mm)	Fracture Surface (mm)	Weld Root Penetration (mm)	Fracture Angle (°)
1	7.8	6.5	5.7	76.0	7.3	7.0	6.0	76.1	7.8	7.8	0.6	0
2	7.9	5.9	5.6	76.0	7.7	5.7	6.0	76.1	8.4	8.4	0.8	0
3	8.7	6.0	5.9	76.0	8.2	6.1	5.7	76.0	9.1	9.1	0.8	0
4	7.4	6.5	5.9	76.0	8.2	6.2	5.9	76.1	9.1	6.7	0.9	17
5	7.9	6.5	5.6	76.0	8.4	6.0	6.4	76.0	9.0	5.9	0.5	37
6	7.8	6.2	5.9	76.0	9.1	6.2	6.2	76.0	8.8	5.5	-0.3	27
7	8.2	6.2	5.9	76.0	8.2	6.5	6.2	76.0	8.1	7.5	-0.1	16
8	7.9	6.3	5.9	76.0	8.5	6.5	6.2	76.0	9.2	6.7	0.7	18
Mean	7.9	6.3	5.8	76.0	8.2	6.3	6.1	76.1	8.7	7.2	0.5	14

Table C30 – Weld Measurements for Specimen T10-3 (E70T-4(L)S 6.4 mm)

Meas. Number	Before Failure						After Failure					
	Front Face			Back Face			Failure Face			Failure Face		
	Shear Leg (mm)	Tension Leg (mm)	45° Meas. (mm)	Weld Length (mm)	Shear Leg (mm)	Tension Leg (mm)	45° Meas. (mm)	Weld Length (mm)	Shear Leg After Fracture (mm)	Fracture Surface (mm)	Weld Root Penetration (mm)	Fracture Angle (°)
1	8.7	6.6	6.0	76.0	8.9	7.1	6.2	76.0	10.1	5.3	1.4	75
2	8.5	6.0	6.2	76.0	9.1	6.7	6.2	76.0	9.1	5.0	0.6	51
3	7.9	5.9	6.0	76.0	9.2	6.6	6.0	76.0	9.2	5.9	1.3	30
4	7.8	5.8	5.9	76.0	8.5	6.2	6.0	76.0	8.8	5.6	1.0	27
5	7.7	6.9	6.0	76.1	8.4	6.3	6.2	76.1	8.8	5.8	1.1	31
6	7.8	6.5	6.4	76.0	8.7	6.3	6.0	76.0	7.9	7.5	0.2	0
7	6.8	6.5	6.0	76.0	8.3	6.6	6.2	76.0	8.3	8.3	1.4	0
8	7.0	6.4	6.0	76.0	7.6	7.1	6.2	76.0	7.8	7.8	0.8	0
Mean	7.8	6.3	6.1	76.0	8.6	6.6	6.1	76.0	8.7	6.4	1.0	27

Table C31 – Weld Measurements for Specimen T11-1 (E70T-7(H)W 6.4 mm)

Meas. Number	Before Failure						After Failure					
	Front Face			Back Face			Front Face			Back Face		
	Shear Leg (mm)	Tension Leg (mm)	45° Meas. (mm)	Weld Length (mm)	Shear Leg (mm)	Tension Leg (mm)	45° Meas. (mm)	Weld Length (mm)	Shear Leg After Fracture (mm)	Fracture Surface (mm)	Weld Root Penetration (mm)	Fracture Angle (°)
1	6.0	6.2	5.7	76.1	7.4	6.8	6.2	76.1	8.8	8.8	2.8	0
2	6.4	6.3	6.0	76.1	7.8	7.1	6.2	76.1	8.6	8.6	2.2	0
3	6.3	6.3	6.2	76.1	7.9	7.1	6.4	76.1	8.4	8.4	2.1	0
4	6.6	6.3	6.2	76.1	7.6	7.1	6.4	76.1	9.1	9.1	2.4	0
5	7.0	6.8	6.2	76.1	7.7	6.8	6.4	76.1	9.2	9.2	2.2	0
6	6.2	7.1	6.2	76.1	7.5	6.7	6.2	76.1	8.6	8.6	2.3	0
7	6.7	7.2	6.4	76.1	7.3	6.5	6.4	76.1	11.4	11.4	4.7	0
8	6.2	7.2	6.4	76.1	8.0	6.5	6.4	76.1	8.7	8.7	2.5	0
Mean	6.4	6.7	6.2	76.1	7.6	6.8	6.3	76.1	9.1	9.1	2.7	0

Table C32 – Weld Measurements for Specimen T11-2 (E70T-7(H)W 6.4 mm)

Meas. Number	Before Failure						After Failure					
	Front Face			Back Face			Front Face			Back Face		
	Shear Leg (mm)	Tension Leg (mm)	45° Meas. (mm)	Weld Length (mm)	Shear Leg (mm)	Tension Leg (mm)	45° Meas. (mm)	Weld Length (mm)	Shear Leg After Fracture (mm)	Fracture Surface (mm)	Weld Root Penetration (mm)	Fracture Angle (°)
1	7.1	7.0	6.4	76.1	7.3	6.7	5.1	76.0	9.5	9.5	2.3	0
2	6.5	7.2	6.4	76.1	7.7	6.9	4.9	76.0	9.7	9.7	2.0	0
3	6.7	7.1	6.4	76.1	7.1	7.0	6.4	76.0	9.3	9.3	2.2	0
4	6.1	7.4	6.2	76.2	6.8	6.8	6.2	76.0	9.3	9.3	2.5	0
5	6.7	7.4	6.2	76.1	6.8	7.0	6.4	76.0	10.1	10.1	3.3	0
6	6.7	7.0	6.2	76.1	6.7	6.9	6.0	76.0	10.1	10.1	3.4	0
7	6.8	7.2	6.4	76.1	7.1	6.5	6.2	76.0	9.8	9.8	2.8	0
8	6.7	7.3	6.0	76.1	7.1	6.7	6.4	76.0	9.6	9.6	2.5	0
Mean	6.7	7.2	6.3	76.1	7.1	6.8	5.9	76.0	9.7	9.7	2.6	0

Table C33 – Weld Measurements for Specimen T11-3 (E70T-7(H)W 6.4 mm)

Meas. Number	Before Failure						After Failure					
	Front Face			Back Face			Front Face			Back Face		
	Shear Leg (mm)	Tension Leg (mm)	45° Meas. (mm)	Weld Length (mm)	Shear Leg (mm)	Tension Leg (mm)	45° Meas. (mm)	Weld Length (mm)	Shear Leg After Fracture (mm)	Fracture Surface (mm)	Weld Root Penetration (mm)	Fracture Angle (°)
1	6.1	7.3	6.2	76.2	7.2	6.4	6.2	76.2	8.4	8.4	2.3	0
2	6.3	7.2	6.2	76.2	7.2	7.1	6.5	76.1	8.2	8.2	1.9	0
3	6.1	6.9	6.0	76.2	7.7	7.3	6.5	76.1	8.1	8.1	2.0	0
4	6.4	7.3	6.0	76.2	7.1	7.1	6.4	76.1	8.4	8.4	2.1	0
5	6.6	7.1	6.0	76.2	7.3	6.9	6.4	76.1	8.5	8.5	1.9	0
6	6.8	7.2	6.2	76.2	6.8	6.6	6.2	76.1	8.4	8.4	1.6	0
7	6.7	7.4	6.4	76.2	6.6	6.7	6.2	76.1	8.4	8.4	1.8	0
8	6.8	7.6	6.2	76.2	7.3	6.7	6.2	76.1	9.1	9.1	2.2	0
Mean	6.5	7.2	6.2	76.2	7.1	6.9	6.3	76.1	8.4	8.4	2.0	0

Table C34 – Weld Measurements for Specimen T12-1 (E70T-7(H)S 6.4 mm)

Meas. Number	Before Failure						After Failure					
	Front Face			Back Face			Front Face			Back Face		
	Shear Leg (mm)	Tension Leg (mm)	45° Meas. (mm)	Weld Length (mm)	Shear Leg (mm)	Tension Leg (mm)	45° Meas. (mm)	Weld Length (mm)	Shear Leg After Fracture (mm)	Fracture Surface (mm)	Weld Root Penetration (mm)	Fracture Angle (°)
1	8.2	6.2	6.2	76.1	7.5	4.6	5.1	76.1	9.9	5.7	2.4	90
2	7.3	6.1	6.0	76.1	8.0	4.9	4.8	76.1	9.5	4.7	1.5	90
3	8.3	6.4	6.2	76.1	6.9	5.2	5.1	76.1	9.3	5.2	2.4	46
4	7.8	6.1	6.0	76.1	6.6	5.4	4.8	76.1	9.5	7.3	2.9	20
5	8.3	6.4	6.2	76.1	7.9	5.5	5.2	76.1	10.4	6.4	2.5	90
6	7.8	6.6	6.2	76.1	8.7	5.4	5.4	76.1	10.4	5.6	1.7	90
7	8.1	6.2	6.0	76.1	8.6	6.1	5.4	76.1	11.3	5.8	2.7	90
8	7.3	6.1	5.7	76.1	8.4	6.0	5.1	76.1	10.2	5.3	1.8	90
Mean	7.9	6.3	6.1	76.1	7.8	5.4	5.1	76.1	10.1	5.7	2.2	76

Table C35 – Weld Measurements for Specimen T12-2 (E70T-7(H)S 6.4 mm)

Meas. Number	Before Failure						After Failure					
	Front Face			Back Face			Front Face			Back Face		
	Shear Leg (mm)	Tension Leg (mm)	45° Meas. (mm)	Weld Length (mm)	Shear Leg (mm)	Tension Leg (mm)	45° Meas. (mm)	Weld Length (mm)	Shear Leg After Fracture (mm)	Fracture Surface (mm)	Weld Root Penetration (mm)	Fracture Angle (°)
1	8.0	6.6	6.0	76.0	7.8	5.2	5.6	75.9	9.5	6.0	1.7	35
2	8.1	5.8	5.9	75.9	7.6	5.2	5.6	75.9	10.4	4.9	2.8	90
3	7.8	6.0	5.9	75.9	8.0	5.9	5.4	75.9	10.6	5.8	2.7	90
4	7.7	6.1	5.7	76.0	7.8	4.8	4.8	75.9	9.8	4.7	2.0	90
5	8.5	5.8	5.9	76.0	7.4	5.1	4.9	75.9	9.5	4.8	2.1	90
6	8.7	5.6	5.4	76.0	7.9	5.3	4.9	75.9	9.8	5.6	2.0	32
7	7.4	5.7	5.2	76.0	8.3	4.2	4.8	75.9	9.4	4.5	1.2	90
8	7.7	5.7	5.4	76.0	8.0	4.9	4.9	75.9	9.8	5.3	1.8	49
Mean	8.0	5.9	5.7	75.9	7.8	5.1	5.1	75.9	9.9	5.2	2.0	71

Table C36 – Weld Measurements for Specimen T12-3 (E70T-7(H)S 6.4 mm)

Meas. Number	Before Failure						After Failure					
	Front Face			Back Face			Front Face			Back Face		
	Shear Leg (mm)	Tension Leg (mm)	45° Meas. (mm)	Weld Length (mm)	Shear Leg (mm)	Tension Leg (mm)	45° Meas. (mm)	Weld Length (mm)	Shear Leg After Fracture (mm)	Fracture Surface (mm)	Weld Root Penetration (mm)	Fracture Angle (°)
1	8.4	5.5	5.4	76.1	8.9	6.0	5.6	76.1	10.4	5.5	2.0	90
2	7.7	5.3	5.2	76.1	8.4	5.7	5.4	76.1	10.0	5.5	2.2	90
3	7.5	6.0	5.7	76.1	8.4	5.3	5.1	76.0	10.6	6.2	3.2	90
4	7.5	6.3	5.9	76.1	8.3	5.2	4.9	76.0	10.4	6.1	2.9	90
5	7.1	6.4	5.9	76.1	8.2	5.0	4.8	76.0	10.2	6.4	3.0	90
6	6.9	5.9	5.9	76.1	8.3	5.3	5.1	76.0	10.0	6.5	3.1	90
7	7.8	7.2	5.9	76.1	7.6	5.5	5.1	76.0	10.8	6.1	3.0	90
8	7.4	6.7	5.7	76.1	7.7	5.6	5.2	76.0	10.6	6.2	3.2	90
Mean	7.5	6.2	5.7	76.1	8.2	5.4	5.1	76.0	10.4	6.1	2.8	90

Table C37 – Weld Measurements for Specimen T13-1 (E70T-7(L)W 6.4 mm)

Meas. Number	Before Failure						After Failure					
	Front Face			Back Face			Failure Face			Failure Face		
	Shear Leg (mm)	Tension Leg (mm)	45° Meas. (mm)	Weld Length (mm)	Shear Leg (mm)	Tension Leg (mm)	45° Meas. (mm)	Weld Length (mm)	Shear Leg After Fracture (mm)	Fracture Surface (mm)	Weld Root Penetration (mm)	Fracture Angle (°)
1	6.5	5.8	4.9	75.9	5.7	6.1	4.8	75.8	9.5	5.8	2.9	90
2	6.8	5.1	4.8	75.9	6.8	6.4	4.8	75.9	9.3	4.4	2.5	90
3	6.8	4.8	4.9	75.9	6.6	6.9	4.8	75.9	9.0	4.7	2.1	90
4	6.4	4.9	4.8	75.9	6.7	6.9	5.1	75.8	9.0	4.9	2.6	90
5	7.0	5.0	4.6	75.9	7.2	6.6	5.1	75.9	9.3	4.7	2.3	90
6	6.7	5.3	4.8	75.9	7.0	7.2	5.1	75.9	9.3	4.9	2.7	90
7	6.7	5.4	4.8	75.9	7.2	6.6	4.8	75.9	9.5	4.8	2.8	90
8	6.8	5.5	4.8	75.9	7.2	6.0	4.4	75.9	9.5	4.8	2.6	90
Mean	6.7	5.2	4.8	75.9	6.8	6.6	4.8	75.9	9.3	4.9	2.6	90

Table C38 – Weld Measurements for Specimen T13-2 (E70T-7(L)W 6.4 mm)

Meas. Number	Before Failure						After Failure					
	Front Face			Back Face			Failure Face			Failure Face		
	Shear Leg (mm)	Tension Leg (mm)	45° Meas. (mm)	Weld Length (mm)	Shear Leg (mm)	Tension Leg (mm)	45° Meas. (mm)	Weld Length (mm)	Shear Leg After Fracture (mm)	Fracture Surface (mm)	Weld Root Penetration (mm)	Fracture Angle (°)
1	6.5	7.5	5.4	76.0	6.5	5.1	5.4	76.1				
2	5.9	6.7	5.2	76.0	7.8	7.1	5.7	76.1				
3	6.4	5.6	5.1	76.0	6.7	5.3	5.2	76.1				
4	6.8	5.4	5.1	76.0	6.8	5.2	5.2	76.1				
5	6.4	5.9	4.9	76.0	7.7	6.1	5.6	76.1				
6	6.9	5.5	4.8	76.0	7.5	6.1	5.6	76.1				
7	6.8	5.1	5.2	76.0	7.2	6.7	5.6	76.1				
8	6.2	6.5	4.9	76.0	7.8	6.0	5.6	76.1				
Mean	6.5	6.0	5.1	76.0	7.3	5.9	5.5	76.1				

Table C39 – Weld Measurements for Specimen T13-3 (E70T-7(L)W 6.4 mm)

Meas. Number	Front Face			Back Face			Failure Face					
	Shear Leg (mm)	Tension Leg (mm)	45° Meas. (mm)	Weld Length (mm)	Shear Leg (mm)	Tension Leg (mm)	45° Meas. (mm)	Weld Length (mm)	Shear Leg After Fracture (mm)	Fracture Surface (mm)	Weld Root Penetration (mm)	Fracture Angle (°)
1	5.1	5.9	4.8	76.0	5.1	6.1	4.8	75.9	9.1	6.5	4.0	90
2	6.4	5.5	5.1	76.0	5.7	5.8	5.2	76.0	10.4	6.0	4.0	90
3	5.3	6.3	4.8	76.0	4.4	7.3	4.9	75.9	8.6	8.6	3.3	0
4	5.9	6.0	4.8	76.0	5.0	6.0	5.1	75.9	9.5	9.5	3.5	0
5	6.7	5.7	5.1	76.0	5.6	5.2	5.1	76.0	10.1	7.9	3.4	12
6	5.5	5.7	5.1	76.0	5.9	4.8	4.8	76.0	8.9	6.7	3.5	23
7	6.6	5.6	5.2	76.0	6.2	5.4	4.9	76.0	9.7	5.9	3.2	90
8	8.2	4.2	4.8	76.0	6.1	5.8	5.2	76.0	10.4	4.6	2.2	90
Mean	6.2	5.6	4.9	76.0	5.5	5.8	5.0	75.9	9.6	7.0	3.4	49

Table C40 – Weld Measurements for Specimen T14-1 (E70T-7(L)S 6.4 mm)

Meas. Number	Before Failure			Back Face			After Failure					
	Shear Leg (mm)	Tension Leg (mm)	45° Meas. (mm)	Weld Length (mm)	Shear Leg (mm)	Tension Leg (mm)	45° Meas. (mm)	Weld Length (mm)	Shear Leg After Fracture (mm)	Fracture Surface (mm)	Weld Root Penetration (mm)	Fracture Angle (°)
1	8.4	6.8	6.0	76.0	8.3	6.5	5.9	76.0	11.3	11.3	3.0	0
2	8.0	6.0	6.0	76.0	8.2	6.6	6.2	76.0	11.4	11.4	3.1	0
3	8.1	6.7	6.2	76.0	8.9	7.3	5.9	76.0	9.9	9.9	1.0	0
4	8.2	6.9	6.4	76.0	9.0	7.0	5.9	76.0	12.6	12.6	3.5	0
5	8.2	6.9	6.5	76.0	8.9	6.7	5.9	76.0	10.1	7.8	1.2	12
6	8.3	7.4	6.4	76.0	9.0	6.8	6.0	76.0	10.4	7.6	1.4	14
7	8.3	6.8	6.2	76.0	8.6	7.1	6.2	76.0	10.2	7.6	1.6	16
8	7.9	6.6	5.9	76.0	8.5	7.4	6.4	76.0	9.4	7.9	0.9	10
Mean	8.2	6.8	6.2	76.0	8.7	6.9	6.0	76.0	10.6	9.5	2.0	6

Table C41 – Weld Measurements for Specimen T14-2 (E70T-7(L)S 6.4 mm)

Meas. Number	Before Failure						After Failure					
	Front Face			Back Face			Front Face			Back Face		
	Shear Leg (mm)	Tension Leg (mm)	45° Meas. (mm)	Weld Length (mm)	Shear Leg (mm)	Tension Leg (mm)	45° Meas. (mm)	Weld Length (mm)	Shear Leg After Fracture (mm)	Fracture Surface (mm)	Weld Root Penetration (mm)	Fracture Angle (°)
1	8.4	6.4	5.7	76.1	8.0	6.9	5.6	76.1	11.4	11.4	3.4	0
2	7.9	6.6	5.7	76.1	8.7	6.7	5.7	76.1	11.9	11.9	3.2	0
3	8.0	6.2	6.0	76.1	8.5	6.5	5.7	76.1	10.3	10.2	1.8	0
4	8.4	7.2	6.4	76.1	8.9	6.8	5.7	76.1	13.4	10.8	4.4	11
5	8.6	7.2	6.0	76.1	8.9	6.5	5.9	76.1	10.3	8.2	1.5	10
6	7.9	6.8	5.9	76.1	8.7	6.9	5.9	76.1	10.7	8.3	2.0	13
7	8.2	7.0	5.9	76.1	8.8	6.9	6.0	76.1	10.4	7.8	1.5	15
8	8.6	6.9	5.9	76.1	9.1	6.9	6.0	76.1	10.3	7.4	1.2	18
Mean	8.3	6.8	5.9	76.1	8.7	6.7	5.8	76.1	11.1	9.5	2.4	8

Table C42 – Weld Measurements for Specimen T14-3 (E70T-7(L)S 6.4 mm)

Meas. Number	Before Failure						After Failure					
	Front Face			Back Face			Front Face			Back Face		
	Shear Leg (mm)	Tension Leg (mm)	45° Meas. (mm)	Weld Length (mm)	Shear Leg (mm)	Tension Leg (mm)	45° Meas. (mm)	Weld Length (mm)	Shear Leg After Fracture (mm)	Fracture Surface (mm)	Weld Root Penetration (mm)	Fracture Angle (°)
1	8.1	6.6	5.9	76.1	8.5	6.3	5.7	76.0	10.0	10.0	1.9	0
2	8.3	7.0	6.7	76.1	8.8	6.6	5.6	76.0	10.0	10.0	1.7	0
3	7.9	7.1	6.5	76.0	8.0	6.1	5.7	76.0	9.7	9.7	1.8	0
4	8.1	7.3	6.0	76.0	8.3	6.5	5.7	76.0	10.3	8.6	2.2	12
5	7.6	7.0	6.0	76.1	8.2	6.3	5.9	76.0	9.8	7.7	2.1	12
6	7.8	6.9	6.0	76.0	8.3	7.0	6.0	76.0	9.5	8.6	1.9	6
7	7.5	6.7	5.9	76.0	8.8	7.2	6.4	76.0	9.5	8.7	2.0	5
8	7.8	6.9	6.0	76.0	9.3	7.1	6.0	76.0	12.6	12.6	4.8	0
Mean	7.9	6.9	6.1	76.0	8.5	6.6	5.9	76.0	10.2	9.5	2.3	4

Table C43 – Weld Measurements for Specimen T15-1 (E70T-7(L)S 6.4 mm)

Meas. Number	Before Failure						After Failure					
	Front Face			Back Face			Front Face			Back Face		
	Shear Leg (mm)	Tension Leg (mm)	45° Meas. (mm)	Weld Length (mm)	Shear Leg (mm)	Tension Leg (mm)	45° Meas. (mm)	Weld Length (mm)	Shear Leg After Fracture (mm)	Fracture Surface (mm)	Weld Root Penetration (mm)	Fracture Angle (°)
1	6.8	6.3	5.4	76.0	7.6	6.9	6.4	76.1	9.8	9.8	3.0	0
2	6.6	6.2	5.4	76.1	6.9	7.3	6.0	76.0	9.1	9.1	2.5	0
3	7.0	7.0	5.4	76.1	6.8	6.6	6.0	76.0	10.0	10.0	3.1	0
4	6.6	7.0	5.6	76.0	8.1	6.4	6.2	76.1	9.8	9.8	3.2	0
5	6.9	6.9	5.6	76.1	7.9	6.0	6.0	76.0	9.5	9.5	2.6	0
6	7.1	6.9	5.4	76.0	8.6	6.7	6.5	76.0	9.7	9.7	2.7	0
7	6.2	6.5	5.6	76.0	7.6	6.9	6.5	76.0	8.5	8.5	2.3	0
8	7.1	7.3	6.0	76.1	8.1	8.0	6.4	76.1	9.5	9.5	2.4	0
Mean	6.8	6.7	5.5	76.1	7.7	6.8	6.3	76.1	9.5	9.5	2.7	0

Table C44 – Weld Measurements for Specimen T15-2 (E70T-7(L)S 6.4 mm)

Meas. Number	Before Failure						After Failure					
	Front Face			Back Face			Front Face			Back Face		
	Shear Leg (mm)	Tension Leg (mm)	45° Meas. (mm)	Weld Length (mm)	Shear Leg (mm)	Tension Leg (mm)	45° Meas. (mm)	Weld Length (mm)	Shear Leg After Fracture (mm)	Fracture Surface (mm)	Weld Root Penetration (mm)	Fracture Angle (°)
1	7.3	7.5	6.2	76.0	7.5	7.4	6.5	76.0	10.4	10.4	3.1	0
2	6.7	7.6	6.2	76.0	7.6	7.5	6.4	76.0	9.7	9.7	3.1	0
3	7.8	7.8	5.9	76.0	7.7	7.6	6.0	76.0	10.8	10.8	3.0	0
4	7.9	7.5	5.6	76.0	7.5	7.3	6.0	76.1	9.9	9.9	2.0	0
5	7.1	6.3	5.7	76.0	8.0	7.3	6.2	76.0	9.0	9.0	1.9	0
6	7.9	7.5	5.9	76.0	8.0	7.0	6.2	76.0	10.5	10.5	2.6	0
7	7.0	7.1	5.7	76.0	7.6	6.9	5.7	76.0	9.9	9.9	2.9	0
8	7.6	7.1	6.0	76.0	8.1	7.2	6.4	76.0	9.7	9.7	2.1	0
Mean	7.4	7.3	5.9	76.0	7.7	7.3	6.2	76.0	10.0	10.0	2.6	0

Table C45 – Weld Measurements for Specimen T15-3 (E70T-7(L)S 6.4 mm)

Meas. Number	Before Failure						After Failure					
	Front Face			Back Face			Front Face			Back Face		
	Shear Leg (mm)	Tension Leg (mm)	45° Meas. (mm)	Weld Length (mm)	Shear Leg (mm)	Tension Leg (mm)	45° Meas. (mm)	Weld Length (mm)	Shear Leg After Fracture (mm)	Fracture Surface (mm)	Weld Root Penetration (mm)	Fracture Angle (°)
1	7.3	7.3	6.0	76.2	7.3	7.3	6.0	76.1	10.3	10.3	3.0	0
2	6.5	7.4	6.0	76.1	7.4	7.3	6.2	76.1	8.7	8.7	2.2	0
3	6.9	8.0	6.0	76.1	7.3	6.5	6.4	76.1	9.2	9.2	2.3	0
4	6.9	7.2	5.7	76.2	7.6	7.0	6.5	76.2	8.8	8.8	1.9	0
5	7.7	7.3	5.6	76.1	7.8	7.3	6.4	76.1	9.8	9.8	2.1	0
6	7.9	6.2	5.6		7.4	7.1	6.0		9.3	9.3	1.4	0
7	6.8	5.4	5.4		7.7	6.9	6.0		8.6	8.6	1.8	0
8	7.2	6.9	6.0		7.2	7.1	6.4		9.4	9.4	2.2	0
Mean	7.2	7.0	5.8	76.1	7.5	7.1	6.2	76.1	9.3	9.3	2.1	0

Table C46 – Weld Measurements for Specimen T16-1 (E70T7-K2(L)W 6.4 mm)

Meas. Number	Before Failure						After Failure					
	Front Face			Back Face			Front Face			Back Face		
	Shear Leg (mm)	Tension Leg (mm)	45° Meas. (mm)	Weld Length (mm)	Shear Leg (mm)	Tension Leg (mm)	45° Meas. (mm)	Weld Length (mm)	Shear Leg After Fracture (mm)	Fracture Surface (mm)	Weld Root Penetration (mm)	Fracture Angle (°)
1	5.1	6.0	4.9	76.2	7.2	7.7	6.4	76.2	9.7	7.1	2.4	18
2	5.7	6.9	5.9	76.2	7.9	7.3	6.4	76.2	9.9	6.7	2.0	20
3	8.0	7.9	5.7	76.2	7.6	7.2	6.5	76.2	10.1	7.5	2.5	16
4	8.0	7.7	5.7	76.2	7.5	7.6	6.7	76.2	10.1	7.0	2.5	20
5	7.3	7.5	5.4	76.2	8.0	7.7	6.7	76.2	10.3	7.4	2.3	16
6	6.7	7.0	5.1		7.8	7.4	6.5		10.5	8.0	2.7	14
7	6.5	6.9	5.2		7.8	7.5	6.4		10.6	7.0	2.8	19
8	6.5	7.0	5.2		7.8	8.0	6.7		10.5	7.1	2.7	21
Mean	6.7	7.1	5.4	76.2	7.7	7.5	6.5	76.2	10.2	7.2	2.5	18

Table C47 – Weld Measurements for Specimen T16-2 (E70T7-K2(L)W 6.4 mm)

Meas. Number	Before Failure						After Failure					
	Front Face			Back Face			Failure Face			Failure Face		
	Shear Leg (mm)	Tension Leg (mm)	45° Meas. (mm)	Weld Length (mm)	Shear Leg (mm)	Tension Leg (mm)	45° Meas. (mm)	Weld Length (mm)	Shear Leg After Fracture (mm)	Fracture Surface (mm)	Weld Root Penetration (mm)	Fracture Angle (°)
1	6.8	7.2	5.6	76.2	7.9	7.8	6.7	76.2				
2	6.6	7.0	5.2	76.2	7.8	8.0	6.5	76.2				
3	6.7	6.3	5.2	76.2	8.0	7.6	6.7	76.2				
4	6.8	6.9	5.4	76.2	8.1	8.0	6.7	76.2				
5	7.1	6.7	5.4	76.2	8.0	7.9	6.5	76.3				
6	6.6	6.7	5.2	76.2	8.3	8.5	6.4					
7	6.4	6.9	5.7	76.2	8.1	8.3	6.4					
8	7.1	7.1	5.2	76.2	8.2	7.4	6.7					
Mean	6.7	6.8	5.4	76.2	8.1	7.9	6.5	76.2				

Table C48 – Weld Measurements for Specimen T16-3 (E70T7-K2(L)W 6.4 mm)

Meas. Number	Before Failure						After Failure					
	Front Face			Back Face			Failure Face			Failure Face		
	Shear Leg (mm)	Tension Leg (mm)	45° Meas. (mm)	Weld Length (mm)	Shear Leg (mm)	Tension Leg (mm)	45° Meas. (mm)	Weld Length (mm)	Shear Leg After Fracture (mm)	Fracture Surface (mm)	Weld Root Penetration (mm)	Fracture Angle (°)
1	6.8	7.0	5.6	71.7	6.7	5.9	5.4	71.6	9.4	6.3	2.8	22
2	6.8	7.1	5.4	71.7	6.5	6.0	5.7	71.7	9.4	6.3	2.9	22
3	7.3	6.9	5.6	71.7	7.2	6.4	5.9	71.6	9.4	6.9	2.2	22
4	6.9	7.2	5.6	71.8	7.9	6.8	6.0	71.6	10.3	6.7	2.4	20
5	6.7	7.2	5.6	71.7	7.8	6.9	5.9	71.7	10.1	6.6	2.3	20
6	7.1	7.0	5.6	71.7	7.2	6.9	5.9	71.7	10.0	6.6	2.9	20
7	6.7	7.2	5.4	71.7	7.4	6.0	5.9	71.7	9.8	6.8	2.4	20
8	6.6	7.4	4.8	71.7	7.1	7.0	5.9	71.6	10.0	7.3	2.8	19
Mean	6.9	7.1	5.4	71.7	7.2	6.5	5.8	71.6	9.8	6.7	2.6	21

Table C49 – Weld Measurements for Specimen T17-1 (E70T7-K2(L)S 6.4 mm)

Meas. Number	Before Failure						After Failure					
	Front Face			Back Face			Failure Face			Failure Face		
	Shear Leg (mm)	Tension Leg (mm)	45° Meas. (mm)	Weld Length (mm)	Shear Leg (mm)	Tension Leg (mm)	45° Meas. (mm)	Weld Length (mm)	Shear Leg After Fracture (mm)	Fracture Surface (mm)	Weld Root Penetration (mm)	Fracture Angle (°)
1	9.4	5.7	5.6	76.1	9.0	5.7	5.6	76.0	10.5	7.3	1.1	21
2	8.1	4.8	4.8	76.1	8.8	5.7	5.6	76.1	9.6	7.1	1.5	20
3	8.2	5.2	4.8	76.1	8.3	4.9	5.6	76.1	9.8	6.9	1.7	25
4	9.0	5.5	5.2	76.2	9.8	5.7	5.6	76.1	12.1	4.5	3.1	90
5	9.1	4.9	4.9	76.1	9.7	5.6	5.2	76.1	12.1	4.3	3.0	90
6	9.1	5.2	5.1	76.1	9.4	5.0	5.2	76.1	11.7	4.8	2.6	90
7	9.4	5.1	4.9	76.1	9.8	5.4	5.4	76.1	12.2	4.7	2.8	90
8	10.0	4.0	4.6	76.1	9.4	5.3	5.2	76.1	13.0	3.6	3.1	90
Mean	9.0	5.1	5.0	76.1	9.2	5.4	5.4	76.1	11.4	5.4	2.4	64

Table C50 – Weld Measurements for Specimen T17-2 (E70T7-K2(L)S 6.4 mm)

Meas. Number	Before Failure						After Failure					
	Front Face			Back Face			Failure Face			Failure Face		
	Shear Leg (mm)	Tension Leg (mm)	45° Meas. (mm)	Weld Length (mm)	Shear Leg (mm)	Tension Leg (mm)	45° Meas. (mm)	Weld Length (mm)	Shear Leg After Fracture (mm)	Fracture Surface (mm)	Weld Root Penetration (mm)	Fracture Angle (°)
1	10.6	3.5	4.4	76.2	9.8	6.0	5.9	76.1	12.4	2.9	1.9	90
2	9.2	5.0	4.8	76.1	10.2	6.0	6.4	76.1	12.4	4.9	3.2	90
3	9.1	4.0	4.4	76.1	9.2	7.4	6.4	76.2	11.9	3.7	2.9	90
4	9.1	3.9	4.0	76.2	8.3	6.7	6.2	76.2	11.9	3.5	2.8	90
5	9.8	3.7	4.1	76.1	8.1	6.6	6.2	76.1	12.2	3.7	2.5	90
6	8.6	3.4	4.4	76.1	8.7	6.9	5.7	76.1	10.9	3.1	2.3	90
7	10.4	5.3	5.2	76.1	9.5	5.9	5.6	76.1	12.6	4.5	2.2	90
8	10.2	4.8	4.8	76.2	8.7	5.1	5.2	76.1	11.7	4.5	1.4	90
Mean	9.6	4.2	4.5	76.2	9.1	6.3	5.9	76.1	12.0	3.8	2.4	90

Table C51 – Weld Measurements for Specimen T17-3 (E70T7-K2(L)S 6.4 mm)

Meas. Number	Before Failure						After Failure					
	Front Face			Back Face			Failure Face			Failure Face		
	Shear Leg (mm)	Tension Leg (mm)	45° Meas. (mm)	Weld Length (mm)	Shear Leg (mm)	Tension Leg (mm)	45° Meas. (mm)	Weld Length (mm)	Shear Leg After Fracture (mm)	Fracture Surface (mm)	Weld Root Penetration (mm)	Fracture Angle (°)
1	9.7	3.9	4.4	76.1	8.9	5.9	6.2	76.2	12.3	3.9	2.6	90
2	9.7	5.1	4.8	76.1	8.8	7.6	6.4	76.1	12.0	4.2	2.3	90
3	9.5	4.2	4.8	76.3	8.0	6.8	6.2	76.0	12.0	3.9	2.5	90
4	9.8	4.5	4.8	76.2	8.2	7.1	6.0	76.1	12.0	4.2	2.2	90
5	10.1	4.1	4.6	76.1	8.0	6.4	6.0	76.2	12.9	4.0	2.9	90
6	9.9	4.5	4.8	76.1	8.6	6.6	5.9	76.2	12.5	4.2	2.6	90
7	9.2	3.7	4.6	76.1	8.1	6.2	5.6	76.2	11.2	3.3	2.0	90
8	10.3	5.1	5.1	76.2	8.3	6.0	5.7	76.1	12.2	4.6	1.9	90
Mean	9.8	4.4	4.7	76.2	8.4	6.6	6.0	76.1	12.1	4.0	2.4	90

Table C52 – Weld Measurements for Specimen T18-1 (E71T8-K6(H)W 6.4 mm)

Meas. Number	Before Failure						After Failure					
	Front Face			Back Face			Failure Face			Failure Face		
	Shear Leg (mm)	Tension Leg (mm)	45° Meas. (mm)	Weld Length (mm)	Shear Leg (mm)	Tension Leg (mm)	45° Meas. (mm)	Weld Length (mm)	Shear Leg After Fracture (mm)	Fracture Surface (mm)	Weld Root Penetration (mm)	Fracture Angle (°)
1	5.3	6.0	4.6	75.9	5.8	6.7	5.1	75.8	9.9	9.9	4.6	0
2	5.2	5.4	4.4	75.9	5.7	6.3	5.1	75.8	9.6	9.6	4.4	0
3	5.8	6.7	5.1	75.9	6.0	6.1	5.2	75.8	9.7	9.7	3.9	0
4	5.6	6.6	5.1	75.9	5.7	6.3	5.2	75.8	9.3	9.3	3.7	0
5	5.7	6.1	5.1	75.9	5.7	6.7	5.2	75.8	9.3	9.3	3.6	0
6	5.7	6.8	5.1	75.9	5.5	6.1	5.4	75.8	9.4	9.4	3.7	0
7	5.2	7.3	5.2	75.9	5.8	6.0	5.4	75.8	9.7	9.7	4.5	0
8	5.7	7.5	5.2	75.9	5.5	6.8	5.2	75.8	9.6	9.6	3.9	0
Mean	5.5	6.5	5.0	75.9	5.7	6.4	5.2	75.8	9.6	9.6	4.0	0

Table C53 – Weld Measurements for Specimen T18-2 (E71T8-K6(H)W 6.4 mm)

Meas. Number	Before Failure						After Failure					
	Front Face			Back Face			Failure Face			Failure Face		
	Shear Leg (mm)	Tension Leg (mm)	45° Meas. (mm)	Weld Length (mm)	Shear Leg (mm)	Tension Leg (mm)	45° Meas. (mm)	Weld Length (mm)	Shear Leg After Fracture (mm)	Fracture Surface (mm)	Weld Root Penetration (mm)	Fracture Angle (°)
1	4.6	7.2	4.8	75.9	5.1	7.0	4.9	75.9	9.1	9.1	4.0	0
2	4.8	6.9	4.8	75.9	5.1	5.2	4.8	76.0	8.5	8.5	3.4	0
3	5.0	6.7	5.2	75.9	5.1	5.8	5.1	75.9	8.6	8.6	3.6	0
4	5.1	6.7	5.1	76.0	5.4	6.3	5.2	76.0	9.1	9.1	3.7	0
5	5.5	6.8	4.8	75.9	5.6	5.1	5.1	75.9	9.0	9.0	3.4	0
6	5.7	6.9	5.1	75.9	5.2	6.1	5.1	75.9	8.5	8.5	3.3	0
7	5.5	7.3	5.1	75.9	5.3	6.6	5.4	75.9	8.6	8.6	3.3	0
8	5.5	6.9	5.2	75.9	5.3	6.9	5.1	75.9	9.1	9.1	3.9	0
Mean	5.2	6.9	5.0	75.9	5.3	6.1	5.1	75.9	8.8	8.8	3.6	0

Table C54 – Weld Measurements for Specimen T18-3 (E71T8-K6(H)W 6.4 mm)

Meas. Number	Before Failure						After Failure					
	Front Face			Back Face			Failure Face			Failure Face		
	Shear Leg (mm)	Tension Leg (mm)	45° Meas. (mm)	Weld Length (mm)	Shear Leg (mm)	Tension Leg (mm)	45° Meas. (mm)	Weld Length (mm)	Shear Leg After Fracture (mm)	Fracture Surface (mm)	Weld Root Penetration (mm)	Fracture Angle (°)
1	5.2	6.5	5.2	75.9	5.1	6.7	4.8	75.9	8.6	8.6	3.5	0
2	6.0	7.2	5.2	75.8	5.7	6.1	5.2	75.9	9.1	9.1	3.4	0
3	6.1	7.4	5.2	75.9	4.8	6.6	5.1	75.9	8.3	8.3	3.6	0
4	5.6	7.9	5.2	75.9	5.3	6.5	4.9	75.9	8.7	8.7	3.5	0
5	6.3	7.1	5.1	76.0	5.7	6.2	5.1	75.9	8.8	7.6	3.1	0
6	5.8	7.3	5.1	76.0	5.4	6.4	5.4	75.9	8.6	8.6	3.3	0
7	5.1	6.6	4.9	75.9	5.1	6.4	5.1	75.9	9.1	9.1	4.0	0
8	5.9	6.3	4.8	75.9	5.4	6.5	5.2	75.9	9.0	9.0	3.6	0
Mean	5.7	7.0	5.1	75.9	5.3	6.4	5.1	75.9	8.8	8.6	3.5	0

Table C55 – Weld Measurements for Specimen T19-1 (E71T8-K6(H)S 6.4 mm)

Meas. Number	Before Failure						After Failure					
	Front Face			Back Face			Failure Face			Failure Face		
	Shear Leg (mm)	Tension Leg (mm)	45° Meas. (mm)	Weld Length (mm)	Shear Leg (mm)	Tension Leg (mm)	45° Meas. (mm)	Weld Length (mm)	Shear Leg After Fracture (mm)	Fracture Surface (mm)	Weld Root Penetration (mm)	Fracture Angle (°)
1	8.0	5.8	5.1	76.1	8.3	7.5	6.0	76.1	10.5	7.3	2.2	19
2	8.0	7.0	5.2	76.1	8.0	6.2	5.4	76.1	9.9	6.3	1.9	22
3	8.0	7.4	5.4	76.1	7.8	6.1	5.4	76.0	9.5	6.1	1.7	22
4	8.1	6.6	5.2	76.1	8.5	6.7	5.6	76.0	10.6	6.6	2.1	24
5	8.3	6.9	5.4	76.1	7.5	7.1	6.0	76.1	10.0	7.2	2.5	20
6	8.4	6.3	5.4	76.1	7.5	7.6	5.9	76.1	10.3	6.6	2.8	22
7	8.2	6.7	5.6	76.1	7.3	6.0	5.4	76.1	9.5	5.8	2.2	30
8	8.1	8.5	5.9	76.1	7.4	6.9	5.4	76.1	9.4	4.9	2.0	37
Mean	8.1	6.9	5.4	76.1	7.8	6.8	5.6	76.1	10.0	6.3	2.2	24

Table C56 – Weld Measurements for Specimen T19-2 (E71T8-K6(H)S 6.4 mm)

Meas. Number	Before Failure						After Failure					
	Front Face			Back Face			Failure Face			Failure Face		
	Shear Leg (mm)	Tension Leg (mm)	45° Meas. (mm)	Weld Length (mm)	Shear Leg (mm)	Tension Leg (mm)	45° Meas. (mm)	Weld Length (mm)	Shear Leg After Fracture (mm)	Fracture Surface (mm)	Weld Root Penetration (mm)	Fracture Angle (°)
1	8.5	8.0	5.9	76.0	7.6	6.2	5.2	76.1	10.6	6.9	3.1	22
2	9.0	7.2	5.7	76.0	7.9	6.2	5.6	76.0	10.5	6.8	2.7	23
3	8.9	7.7	5.9	76.0	7.7	6.5	5.6	76.0	10.1	6.8	2.4	23
4	8.9	8.0	5.7	76.0	8.2	5.8	5.2	76.0	9.6	6.0	1.3	27
5	8.4	7.8	5.7	76.0	7.9	5.9	5.7	76.0	9.3	6.4	1.5	25
6	8.9	8.1	5.7	76.0	8.8	5.4	5.6	76.0	10.5	6.0	1.8	30
7	8.8	6.8	5.6	76.0	8.4	6.1	5.6	76.0	10.2	6.4	1.8	27
8	8.7	7.0	5.9	76.0	8.4	5.7	5.4	76.0	10.0	5.7	1.6	33
Mean	8.8	7.6	5.8	76.0	8.1	6.0	5.5	76.0	10.1	6.4	2.0	26

Table C57 – Weld Measurements for Specimen T19-3 (E71T8-K6(H)S 6.4 mm)

Meas. Number	Before Failure						After Failure					
	Front Face			Back Face			Failure Face			Failure Face		
	Shear Leg (mm)	Tension Leg (mm)	45° Meas. (mm)	Weld Length (mm)	Shear Leg (mm)	Tension Leg (mm)	45° Meas. (mm)	Weld Length (mm)	Shear Leg After Fracture (mm)	Fracture Surface (mm)	Weld Root Penetration (mm)	Fracture Angle (°)
1	9.0	7.3	5.6	75.9	8.2	5.2	5.1	76.0	10.3	5.9	2.1	32
2	8.7	7.0	5.6	75.9	8.9	5.6	5.9	76.1	10.8	6.9	1.9	29
3	8.9	7.1	5.6	75.9	8.3	5.5	5.7	76.0	10.6	6.5	2.3	28
4	9.5	7.4	5.4	75.9	7.7	6.5	5.9	76.0	10.4	6.1	2.6	28
5	8.9	7.4	5.9	75.9	8.3	7.2	5.9	76.1	10.5	6.8	2.2	21
6	7.9	7.4	5.6	75.9	8.2	7.6	5.9	76.1	11.0	8.0	2.7	20
7	8.9	7.1	5.7	75.9	6.8	5.9	5.2	76.0	9.4	6.4	2.5	22
8	7.9	7.1	5.7	75.9	7.2	6.5	4.9	76.0	9.7	6.3	2.5	22
Mean	8.7	7.2	5.6	75.9	8.0	6.2	5.6	76.0	10.3	6.6	2.3	25

Table C58 – Weld Measurements for Specimen T20-1 (E7014(L)W 12.7 mm)

Meas. Number	Before Failure						After Failure					
	Front Face			Back Face			Failure Face			Failure Face		
	Shear Leg (mm)	Tension Leg (mm)	45° Measurements (mm)	Weld Length (mm)	Shear Leg (mm)	Tension Leg (mm)	45° Measurements (mm)	Weld Length (mm)	Shear Leg After Fracture (mm)	Fracture Surface (mm)	Weld Root Penetration (mm)	Fracture Angle (°)
1	13.1	13.6	4.5	75.9	13.4	12.5	4.5	75.8	14.5	9.3	1.4	29
2	12.9	14.7	4.4	75.8	12.2	13.1	4.2	75.8	15.2	9.4	2.2	30
3	13.0	14.2	4.5	75.9	12.5	13.4	4.2	75.8	14.9	9.6	1.9	31
4	13.0	14.2	4.7	75.8	12.9	13.9	4.8	75.8	16.3	11.0	3.3	24
5	13.6	14.3	5.0	75.8	13.3	14.2	4.8	75.8	16.3	10.3	2.7	27
6	13.5	13.8	4.8	75.8	13.5	14.6	5.3	75.8	15.8	10.4	2.3	25
7	13.9	13.9	4.8	75.8	14.7	13.9	6.1	75.8	16.1	10.4	2.2	26
8	14.6	15.0	4.8	75.8	14.0	14.1	5.0	75.8	18.1	10.6	3.5	23
Mean	13.4	14.2	4.7	75.8	13.3	13.7	4.9	75.8	15.9	10.1	2.4	27

Table C59 – Weld Measurements for Specimen T20-2 (E7014(L)W 12.7 mm)

Meas. Number	Before Failure										After Failure					
	Front Face					Back Face					Failure Face		Failure Face			
	Shear Leg (mm)	Tension Leg (mm)	45° Measurements		Weld Length (mm)	Shear Leg (mm)	Tension Leg (mm)	45° Measurements		Weld Length (mm)	Shear Leg After Fracture (mm)	Fracture Surface (mm)	Weld Root Penetration (mm)	Fracture Angle (°)		
			Upper (mm)	Throat (mm)				Lower (mm)	Upper (mm)						Throat (mm)	Lower (mm)
1	13.0	13.1	3.7	9.0	4.9	76.0	13.9	14.5	4.7	9.5	5.7	75.9	14.2	14.2	1.2	0
2	13.1	12.5	3.7	9.0	5.1	76.0	13.4	14.9	4.5	9.4	5.6	75.9	13.5	13.5	0.4	29
3	12.9	13.0	3.7	8.9	4.8	75.9	13.2	14.5	4.8	9.5	5.7	75.9	13.3	13.3	0.4	26
4	12.6	13.1	4.0	9.2	5.1	76.0	13.1	15.2	4.7	9.7	5.9	76.0	13.5	13.5	0.9	0
5	12.4	13.6	4.2	9.2	5.1	76.0	13.1	14.2	4.8	9.7	5.7	75.9	13.3	13.3	1.0	0
6	12.5	14.0	4.0	9.2	5.2	76.0	13.2	14.3	4.7	9.5	5.9	75.9	13.3	13.3	0.8	0
7	13.2	13.0	4.0	9.4	5.2	76.0	13.5	14.8	4.7	9.8	6.0	75.9	14.3	14.3	1.1	0
8	12.7	13.1	4.5	9.5	5.1	76.0	13.5	14.7	4.8	9.8	6.0	75.9	14.2	14.2	1.5	0
Mean	12.8	13.2	4.0	9.2	5.1	76.0	13.4	14.6	4.7	9.6	5.8	75.9	13.7	13.7	0.9	7

Table C60 – Weld Measurements for Specimen T20-3 (E7014(L)W 12.7 mm)

Meas. Number	Before Failure										After Failure					
	Front Face					Back Face					Failure Face		Failure Face			
	Shear Leg (mm)	Tension Leg (mm)	45° Measurements		Weld Length (mm)	Shear Leg (mm)	Tension Leg (mm)	45° Measurements		Weld Length (mm)	Shear Leg After Fracture (mm)	Fracture Surface (mm)	Weld Root Penetration (mm)	Fracture Angle (°)		
			Upper (mm)	Throat (mm)				Lower (mm)	Upper (mm)						Throat (mm)	Lower (mm)
1	12.2	14.3	4.4	9.7	4.9	75.9	13.9	13.3	4.0	9.4	5.1	76.2	13.6	13.6	1.4	0
2	13.1	14.2	4.7	10.0	5.2	76.0	13.9	13.4	4.0	9.2	5.4	76.2	14.7	14.7	1.6	0
3	13.6	14.3	5.1	10.8	6.0	76.0	13.6	13.8	4.5	9.5	5.6	76.2	15.1	15.1	1.5	0
4	13.8	15.0	6.1	11.7	7.0	76.0	14.3	14.0	4.2	9.5	5.6	76.1	13.6	13.6	-0.2	0
5	14.0	13.8	6.7	10.0	6.8	76.1	13.7	13.5	4.5	9.8	5.9	76.2	15.6	14.9	1.6	0
6	13.2	13.9	5.5	9.7	4.9	76.0	13.8	13.1	4.2	9.5	5.9	76.2	15.3	9.8	2.1	20
7	13.4	13.3	5.3	9.4	4.8	76.0	13.9	13.7	4.4	9.5	5.7	76.2	8.8	8.8	1.8	20
8	13.4	14.0	5.3	9.2	4.4	76.0	14.1	13.6	4.4	9.0	5.4	76.2	9.1	9.1	1.9	20
Mean	13.3	14.1	5.4	10.1	5.5	76.0	13.9	13.6	4.3	9.4	5.6	76.2	14.8	12.4	1.5	7.4

Table C61 – Weld Measurements for Specimen T21-1 (E70T-4(H)W 12.7 mm)

Meas. Number	Before Failure										After Failure				
	Front Face					Back Face					Failure Face		Failure Face		
	Shear Leg (mm)	Tension Leg (mm)	45° Measurements		Weld Length (mm)	Shear Leg (mm)	Tension Leg (mm)	45° Measurements		Weld Length (mm)	Shear Leg After Fracture (mm)	Fracture Surface (mm)	Weld Root Penetration (mm)	Fracture Angle (°)	
			Upper (mm)	Throat (mm)				Lower (mm)	Upper (mm)						Throat (mm)
1	12.1	13.4	6.4	11.3	5.1	76.3	12.4	12.7	7.1	10.8	6.0	76.3	14.3	2.2	0
2	12.2	14.0	6.6	11.1	4.8	76.2	12.4	13.1	6.9	11.4	6.0	76.3	14.7	2.6	0
3	11.9	13.9	6.6	11.1	4.8	76.2	12.1	13.6	7.4	11.7	5.9	76.2	14.0	2.1	0
4	11.3	13.7	6.7	11.1	4.8	76.3	11.5	13.1	7.2	11.7	5.7	76.2	13.2	1.9	0
5	10.6	14.3	6.7	11.3	4.6	76.2	11.8	13.3	7.4	11.6	5.9	76.2	12.9	2.3	0
6	11.2	14.2	6.7	10.8	4.6	76.2	12.1	12.8	7.4	11.9	5.6	76.2	13.4	2.2	0
7	10.7	14.1	6.6	11.0	4.8	76.2	12.5	12.9	7.4	11.7	5.9	76.2	12.8	2.1	0
8	10.7	14.1	6.4	10.8	4.6	76.3	13.2	13.2	7.4	11.7	6.0	76.2	12.9	2.3	0
Mean	11.3	14.0	6.6	11.1	4.7	76.3	12.2	13.1	7.3	11.6	5.9	76.2	13.5	2.2	0

Table C62 – Weld Measurements for Specimen T21-2 (E70T-4(H)W 12.7 mm)

Meas. Number	Before Failure										After Failure				
	Front Face					Back Face					Failure Face		Failure Face		
	Shear Leg (mm)	Tension Leg (mm)	45° Measurements		Weld Length (mm)	Shear Leg (mm)	Tension Leg (mm)	45° Measurements		Weld Length (mm)	Shear Leg After Fracture (mm)	Fracture Surface (mm)	Weld Root Penetration (mm)	Fracture Angle (°)	
			Upper (mm)	Throat (mm)				Lower (mm)	Upper (mm)						Throat (mm)
1	11.7	14.0	6.4	11.4	4.8	76.3	12.7	13.7	7.2	11.9	6.0	76.0	16.2	3.5	0
2	12.3	13.7	6.4	11.1	4.9	76.3	12.2	13.6	7.7	11.9	5.9	76.1	14.9	2.8	0
3	12.8	14.0	6.4	11.4	5.2	76.3	11.9	13.6	7.7	12.1	5.9	76.1	14.3	2.4	0
4	11.8	13.2	6.4	11.3	5.2	76.3	12.2	13.7	7.7	12.2	5.9	76.1	15.3	3.2	0
5	12.4	13.6	6.4	11.3	5.4	76.3	11.9	13.5	7.5	12.1	5.7	76.1	15.0	3.1	0
6	12.3	13.7	6.4	11.1	5.4	76.3	12.2	13.4	7.4	12.2	5.7	76.1	14.9	2.7	0
7	12.3	13.8	6.4	11.1	5.4	76.3	11.6	14.4	7.7	12.2	5.6	76.1	14.5	2.9	0
8	12.5	13.6	6.6	11.3	5.1	76.3	11.9	13.7	7.8	12.2	5.6	76.1	14.7	2.8	0
Mean	12.2	13.7	6.4	11.3	5.2	76.3	12.1	13.7	7.6	12.1	5.8	76.1	15.0	2.9	0

Table C63 – Weld Measurements for Specimen T21-3 (E70T-4(H)W 12.7 mm)

Meas. Number	Before Failure										After Failure				
	Front Face					Back Face					Failure Face		Failure Face		
	Shear Leg (mm)	Tension Leg (mm)	45° Measurements		Weld Length (mm)	Shear Leg (mm)	Tension Leg (mm)	45° Measurements		Weld Length (mm)	Shear Leg After Fracture (mm)	Fracture Surface (mm)	Weld Root Penetration (mm)	Fracture Angle (°)	
			Upper (mm)	Throat (mm)				Lower (mm)	Upper (mm)						Throat (mm)
1	13.2	11.5	5.5	10.0	5.9	76.2	12.3	14.4	7.7	12.2	5.9	76.1	14.6	2.3	0
2	12.9	12.4	6.1	10.6	5.4	76.2	12.2	13.8	7.4	11.6	5.9	76.2	14.5	2.3	0
3	13.0	14.1	6.9	11.4	5.6	76.2	12.1	13.8	7.4	11.4	5.7	76.1	14.6	2.5	0
4	12.2	14.1	6.7	11.1	5.4	76.3	12.4	13.5	7.4	11.6	5.7	76.1	14.8	2.5	0
5	11.6	14.3	6.7	11.1	5.1	76.2	12.3	13.1	7.1	11.7	5.7	76.1	14.7	2.5	0
6	11.7	13.8	6.6	10.8	4.9	76.2	11.7	13.6	6.9	11.7	5.6	76.1	13.7	2.0	0
7	11.2	14.0	6.4	10.8	4.4	76.2	12.2	13.1	6.7	11.7	5.9	76.1	14.2	1.9	0
8	11.4	13.7	6.4	11.1	4.8	76.2	12.3	12.3	6.4	11.4	5.9	76.1	14.9	2.6	0
Mean	12.1	13.5	6.4	10.9	5.2	76.2	12.2	13.5	7.1	11.7	5.8	76.1	14.5	2.3	0

Table C64 – Weld Measurements for Specimen T22-1 (E70T-4(H)S 12.7 mm)

Meas. Number	Before Failure										After Failure				
	Front Face					Back Face					Failure Face		Failure Face		
	Shear Leg (mm)	Tension Leg (mm)	45° Measurements		Weld Length (mm)	Shear Leg (mm)	Tension Leg (mm)	45° Measurements		Weld Length (mm)	Shear Leg After Fracture (mm)	Fracture Surface (mm)	Weld Root Penetration (mm)	Fracture Angle (°)	
			Upper (mm)	Throat (mm)				Lower (mm)	Upper (mm)						Throat (mm)
1	9.8	10.0	3.4	7.8	3.2	76.3	10.3	11.3	4.4	9.2	4.0	76.1	12.2	2.4	0
2	9.5	10.9	3.6	7.9	3.0	76.2	10.9	11.6	4.7	9.0	4.1	76.1	12.2	2.8	0
3	9.3	10.6	3.4	7.8	2.9	76.2	10.9	12.0	5.0	9.4	4.1	76.1	12.2	3.0	0
4	8.9	10.7	3.4	7.8	2.9	76.2	10.5	12.2	5.0	9.4	4.1	76.1	12.5	3.6	0
5	9.8	10.3	3.7	7.6	3.2	76.2	11.8	12.1	4.7	9.2	4.4	76.1	12.8	3.0	0
6	9.3	11.3	4.0	8.3	3.5	76.2	11.0	12.2	4.8	8.9	4.4	76.1	10.9	1.6	0
7	9.5	10.7	3.6	7.9	3.7	76.2	12.2	12.0	5.0	9.2	4.4	76.1	12.5	3.0	0
8	9.6	10.6	3.4	7.6	3.2	76.2	11.0	12.0	4.7	9.2	4.3	76.1	12.0	2.5	0
Mean	9.4	10.6	3.6	7.8	3.2	76.2	11.1	11.9	4.8	9.2	4.2	76.1	12.2	2.7	0

Table E65 – Weld measurements for Specimen T22-2 (E70T-4(H)S 12.7 mm)

Meas. Number	Before Failure										After Failure			
	Front Face					Back Face					Failure Face		Failure Face	
	Shear Leg (mm)	Tension Leg (mm)	45° Measurements		Weld Length (mm)	Shear Leg (mm)	Tension Leg (mm)	45° Measurements		Weld Length (mm)	Shear Leg After Fracture (mm)	Fracture Surface (mm)	Weld Root Penetration (mm)	Fracture Angle (°)
			Upper (mm)	Throat (mm)				Lower (mm)	Upper (mm)					
1	9.9	9.4	2.9	7.0	76.1	10.5	11.4	4.8	8.7	3.8	76.1	12.4	2.5	0
2	10.5	10.5	3.6	7.9	76.1	11.3	11.4	4.8	8.9	4.3	76.1	13.2	2.7	0
3	10.2	10.1	3.1	7.6	76.1	11.2	11.3	4.8	9.0	4.3	76.1	12.4	2.2	0
4	8.5	10.2	3.4	8.1	76.1	11.0	11.6	4.8	9.0	3.8	76.1	10.3	1.9	0
5	10.4	10.0	3.2	8.3	76.1	11.9	10.9	4.8	8.9	4.3	76.1	13.2	2.7	0
6	9.7	9.9	3.1	8.4	76.1	10.2	11.9	5.1	9.2	3.7	76.1	12.0	2.3	0
7	11.4	10.0	3.4	8.4	76.1	10.6	11.6	5.0	8.9	3.8	76.1	13.7	2.3	0
8	12.2	10.4	3.4	8.6	76.1	9.9	11.9	4.8	9.0	3.8	76.1	14.4	2.3	0
Mean	10.3	10.0	3.3	8.0	76.1	10.8	11.5	4.9	9.0	4.0	76.1	12.7	2.4	0

Table C66 – Weld Measurements for Specimen T22-3 (E70T-4(H)S 12.7 mm)

Meas. Number	Before Failure										After Failure			
	Front Face					Back Face					Failure Face		Failure Face	
	Shear Leg (mm)	Tension Leg (mm)	45° Measurements		Weld Length (mm)	Shear Leg (mm)	Tension Leg (mm)	45° Measurements		Weld Length (mm)	Shear Leg After Fracture (mm)	Fracture Surface (mm)	Weld Root Penetration (mm)	Fracture Angle (°)
			Upper (mm)	Throat (mm)				Lower (mm)	Upper (mm)					
1	11.7	9.7	3.2	8.3	76.0	10.0	11.6	4.4	8.3	3.2	76.1	14.2	2.5	0
2	11.5	10.4	3.7	8.4	76.0	10.7	11.1	4.0	8.3	3.5	76.1	13.8	2.3	0
3	11.6	10.3	3.4	8.4	76.0	10.1	11.4	4.2	7.9	3.3	76.1	13.9	2.3	0
4	9.5	10.6	3.4	8.1	76.1	9.5	11.5	4.5	8.6	3.0	76.2	11.5	2.0	0
5	11.1	9.9	3.1	8.1	76.1	10.2	11.7	4.0	8.4	3.2	76.1	13.0	1.9	0
6	10.6	9.6	3.2	8.3	76.1	9.5	11.1	4.5	8.1	3.2	76.1	11.9	1.3	0
7	10.4	9.8	3.4	9.0	76.0	10.3	12.0	4.8	9.0	3.7	76.0	11.4	1.0	0
8	12.3	10.6	3.4	8.4	76.0	10.9	12.1	4.7	9.0	3.7	76.0	13.9	1.5	0
Mean	11.1	10.1	3.4	8.4	76.0	10.1	11.6	4.4	8.5	3.3	76.1	12.9	1.8	0

Table C67 – Weld Measurements for Specimen T23-1 (E70T-4(L)W 12.7 mm)

Meas. Number	Before Failure										After Failure					
	Front Face					Back Face					Failure Face		Failure Face			
	Shear Leg (mm)	Tension Leg (mm)	45° Measurements			Weld Length (mm)	Shear Leg (mm)	Tension Leg (mm)	45° Measurements			Weld Length (mm)	Shear Leg After Fracture (mm)	Fracture Surface (mm)	Weld Root Penetration (mm)	Fracture Angle (°)
			Upper (mm)	Throat (mm)	Lower (mm)				Upper (mm)	Throat (mm)	Lower (mm)					
1	12.2	13.8	5.6	10.0	4.8	76.1	13.6	13.3	5.3	10.2	5.1	76.1	17.2	12.7	5.0	16
2	12.1	13.5	5.3	10.0	4.6	76.1	13.6	13.1	5.1	9.8	5.1	76.1	16.2	12.5	4.1	15
3	13.1	13.1	5.3	10.0	4.8	76.1	13.1	12.8	5.0	9.8	5.1	76.1	17.5	13.5	4.4	12
4	13.2	12.5	5.1	10.0	4.8	76.1	13.4	12.7	5.0	10.0	5.1	76.0	17.1	12.9	4.0	13
5	12.4	12.7	5.1	10.3	4.8	76.1	13.6	13.3	5.0	10.2	5.1	76.1	14.6	12.0	2.3	11
6	12.7	12.1	5.1	10.5	5.1	76.1	13.7	13.0	5.1	10.2	5.2	76.1	16.2	13.1	3.4	10
7	12.1	12.7	5.1	10.3	4.6	76.1	13.0	13.3	5.3	10.2	5.1	76.1	15.0	11.4	2.9	12
8	12.7	12.1	5.0	10.5	5.2	76.1	13.9	12.4	5.1	10.0	5.2	76.1	15.8	11.3	3.1	12
Mean	12.6	12.8	5.2	10.2	4.8	76.1	13.5	13.0	5.1	10.0	5.1	76.1	16.2	12.4	3.6	12

Table C68 – Weld Measurements for Specimen T23-2 (E70T-4(L)W 12.7 mm)

Meas. Number	Before Failure										After Failure					
	Front Face					Back Face					Failure Face		Failure Face			
	Shear Leg (mm)	Tension Leg (mm)	45° Measurements			Weld Length (mm)	Shear Leg (mm)	Tension Leg (mm)	45° Measurements			Weld Length (mm)	Shear Leg After Fracture (mm)	Fracture Surface (mm)	Weld Root Penetration (mm)	Fracture Angle (°)
			Upper (mm)	Throat (mm)	Lower (mm)				Upper (mm)	Throat (mm)	Lower (mm)					
1	12.9	12.2	5.0	10.5	5.1	75.9	13.0	12.9	5.1	10.0	5.1	76.1	15.6	12.2	2.7	15
2	12.5	12.7	5.1	10.5	5.2	75.9	13.4	13.2	5.3	10.3	5.2	76.1	15.1	12.5	2.6	13
3	12.3	12.5	5.3	10.6	5.1	75.9	14.0	13.2	5.1	10.2	5.1	76.2	15.3	12.8	3.1	12
4	12.9	13.0	5.5	10.6	5.2	75.9	13.4	12.1	5.1	10.0	5.1	76.3	15.4	12.4	2.5	14
5	12.4	12.9	5.5	10.6	5.2	75.9	13.1	13.0	5.3	10.2	4.8	76.2	14.7	12.0	2.3	13
6	12.4	12.7	5.3	10.6	5.2	75.9	13.6	13.3	5.3	10.2	4.9	76.2	15.1	12.4	2.7	13
7	12.3	12.9	5.5	10.5	4.9	75.9	13.3	13.4	5.3	10.2	4.9	76.2	15.2	11.8	2.9	15
8	12.6	12.8	5.5	10.3	4.8	75.9	13.3	12.7	5.1	10.3	5.1	76.2	15.0	11.8	2.4	15
Mean	12.5	12.7	5.3	10.5	5.1	75.9	13.4	13.0	5.2	10.2	5.0	76.2	15.2	12.2	2.6	14

Table C69 – Weld Measurements for Specimen T23-3 (E70T-4(L)W 12.7 mm)

Meas. Number	Before Failure										After Failure				
	Front Face					Back Face					Failure Face		Failure Face		
	Shear Leg (mm)	Tension Leg (mm)	45° Measurements		Weld Length (mm)	Shear Leg (mm)	Tension Leg (mm)	45° Measurements		Weld Length (mm)	Shear Leg After Fracture (mm)	Fracture Surface (mm)	Weld Root Penetration (mm)	Fracture Angle (°)	
			Upper (mm)	Throat (mm)				Lower (mm)	Upper (mm)						Throat (mm)
1	12.3	13.0	5.3	10.5	5.1	76.0	13.3	13.1	9.8	5.1	76.2	15.0	11.9	2.7	15
2	12.3	13.3	5.5	10.5	5.1	76.0	13.3	13.1	9.8	5.1	75.8	14.7	11.3	2.4	15
3	12.0	13.2	5.5	10.3	5.1	76.1	13.0	12.8	9.8	4.9	75.8	14.8	11.5	2.8	16
4	13.0	12.8	5.5	10.6	5.1	76.2	13.4	12.4	9.8	4.9	75.8	14.8	11.4	1.9	16
5	12.0	13.2	5.6	10.5	5.1	76.2	13.7	12.3	9.8	4.9	75.8	14.4	11.1	2.4	18
6	13.3	13.5	5.6	10.5	5.2	76.2	13.0	12.6	9.8	4.8	75.8	16.0	11.8	2.7	17
7	13.2	13.3	5.8	10.5	5.2	76.2	12.9	12.7	10.0	4.8	75.8	15.4	11.3	2.2	18
8	13.3	13.8	5.6	10.5	5.2	76.2	12.7	13.2	10.0	5.1	75.9	15.9	11.7	2.6	19
Mean	12.7	13.3	5.5	10.5	5.1	76.1	13.2	12.8	9.9	5.0	75.9	15.1	11.5	2.4	17

Table C70 – Weld Measurements for Specimen T24-1 (E70T-4(L)S 12.7 mm)

Meas. Number	Before Failure										After Failure				
	Front Face					Back Face					Failure Face		Failure Face		
	Shear Leg (mm)	Tension Leg (mm)	45° Measurements		Weld Length (mm)	Shear Leg (mm)	Tension Leg (mm)	45° Measurements		Weld Length (mm)	Shear Leg After Fracture (mm)	Fracture Surface (mm)	Weld Root Penetration (mm)	Fracture Angle (°)	
			Upper (mm)	Throat (mm)				Lower (mm)	Upper (mm)						Throat (mm)
1	11.0	11.2	3.4	7.9	3.5	76.2	11.0	11.8	8.7	3.5	76.1	14.2	10.3	3.2	21
2	11.4	10.8	3.4	7.9	3.5	76.1	11.7	11.9	8.1	3.7	76.1	13.9	8.9	2.1	21
3	11.6	11.0	3.7	8.1	3.8	76.2	11.8	12.3	8.6	4.0	76.2	14.5	10.1	2.8	21
4	11.3	11.0	3.7	8.1	3.8	76.2	12.2	11.5	9.0	4.3	76.1	16.7	10.3	4.5	21
5	11.0	11.3	3.7	8.4	3.5	76.2	12.3	11.7	8.7	4.3	76.1	14.0	9.3	1.7	21
6	11.8	11.2	3.6	8.4	3.8	76.2	11.3	12.0	8.9	4.3	76.1	13.3	9.6	2.0	21
7	12.4	10.7	3.4	8.3	4.0	76.2	11.2	11.7	8.6	4.4	76.1	13.3	8.7	2.1	24
8	12.1	10.3	3.2	8.1	3.8	76.2	12.5	11.8	8.4	4.4	76.1	14.7	9.3	2.2	24
Mean	11.6	10.9	3.5	8.2	3.7	76.2	11.7	11.8	8.6	4.2	76.1	14.3	9.6	2.6	22

Table C71 – Weld Measurements for Specimen T24-2 (E70T-4(L)S 12.7 mm)

Meas. Number	Before Failure										After Failure				
	Front Face					Back Face					Failure Face		Failure Face		
	Shear Leg (mm)	Tension Leg (mm)	45° Measurements		Weld Length (mm)	Shear Leg (mm)	Tension Leg (mm)	45° Measurements		Weld Length (mm)	Shear Leg After Fracture (mm)	Fracture Surface (mm)	Weld Root Penetration (mm)	Fracture Angle (°)	
			Upper (mm)	Throat (mm)				Lower (mm)	Upper (mm)						Throat (mm)
1	12.3	10.6	3.4	8.4	4.0	76.1	11.6	10.9	8.3	4.1	76.0	15.2	9.3	3.6	23
2	12.4	10.7	3.6	8.6	4.1	76.0	11.9	11.3	9.0	4.1	76.0	14.6	10.1	2.7	20
3	12.5	10.2	3.1	8.1	4.0	76.0	12.5	11.5	9.0	4.4	76.0	15.2	10.2	2.7	21
4	13.5	10.2	3.2	8.1	4.3	76.1	12.5	11.3	8.9	4.3	76.0	14.8	9.3	2.3	23
5	13.3	10.2	3.2	8.4	4.3	76.1	12.2	11.5	9.0	4.4	76.1	15.0	10.1	2.8	23
6	13.0	10.9	3.6	8.1	4.3	76.1	12.1	11.6	9.2	4.4	76.1	14.5	10.0	2.5	23
7	12.6	10.4	3.4	8.7	4.3	76.1	12.0	11.7	9.0	4.3	76.1	14.9	10.3	2.9	23
8	12.2	10.5	3.4	8.4	4.1	76.1	11.3	11.9	8.7	4.0	76.1	14.5	9.8	3.2	23
Mean	12.7	10.5	3.4	8.4	4.2	76.1	12.0	11.4	8.9	4.4	76.0	14.8	9.9	2.8	22

Table C72 – Weld Measurements for Specimen T24-3 (E70T-4(L)S 12.7 mm)

Meas. Number	Before Failure										After Failure				
	Front Face					Back Face					Failure Face		Failure Face		
	Shear Leg (mm)	Tension Leg (mm)	45° Measurements		Weld Length (mm)	Shear Leg (mm)	Tension Leg (mm)	45° Measurements		Weld Length (mm)	Shear Leg After Fracture (mm)	Fracture Surface (mm)	Weld Root Penetration (mm)	Fracture Angle (°)	
			Upper (mm)	Throat (mm)				Lower (mm)	Upper (mm)						Throat (mm)
1	12.8	10.7	3.4	8.4	3.8	76.0	12.1	11.6	8.3	4.1	76.2	16.1	11.0	3.2	17
2	13.0	10.8	3.4	8.1	4.0	76.1	12.3	11.4	7.9	4.1	76.0	15.6	10.0	2.6	17
3	13.1	10.6	3.2	8.3	4.3	76.0	12.3	11.0	7.8	4.1	76.2	15.6	9.6	2.5	20
4	13.2	10.9	3.4	8.4	4.1	76.0	12.1	11.1	8.3	4.0	76.1	15.6	10.6	2.5	17
5	13.4	10.9	3.6	8.6	4.3	76.0	11.6	11.0	8.3	4.0	76.1	15.7	11.0	2.4	16
6	13.5	10.6	3.4	8.6	4.3	76.0	11.6	10.7	8.4	4.0	76.1	15.6	10.7	2.2	16
7	13.6	10.6	3.4	8.4	4.4	76.0	12.2	11.1	8.4	4.1	76.1	15.6	10.6	2.0	18
8	14.2	10.2	3.1	8.3	4.6	76.0	12.2	10.9	8.4	4.3	76.1	16.3	10.5	2.1	19
Mean	13.4	10.7	3.4	8.4	4.2	76.0	12.0	11.1	8.2	4.1	76.1	15.8	10.5	2.4	17

Table C73 – Weld Measurements for Specimen T25-1 (E70T-7(H)W 12.7 mm)

Meas. Number	Before Failure										After Failure					
	Front Face					Back Face					Failure Face		Failure Face			
	Shear Leg (mm)	Tension Leg (mm)	45° Measurements			Weld Length (mm)	Shear Leg (mm)	Tension Leg (mm)	45° Measurements			Weld Length (mm)	Shear Leg After Fracture (mm)	Fracture Surface (mm)	Weld Root Penetration (mm)	Fracture Angle (°)
			Upper (mm)	Throat (mm)	Lower (mm)				Upper (mm)	Throat (mm)	Lower (mm)					
1	13.3	11.4	4.7	9.5	5.4	76.0	14.6	10.7	4.2	10.2	5.9	76.1				
2	13.7	11.5	4.7	9.5	5.4	76.0	14.9	10.8	4.2	10.2	5.9	76.1				
3	13.4	11.4	4.4	9.5	5.4	76.0	14.5	10.4	4.2	10.2	5.9	76.0				
4	13.4	11.2	4.4	9.5	5.6	76.1	14.5	10.6	4.2	10.0	5.9	76.0				
5	13.9	11.5	4.7	9.5	5.6	76.0	15.4	10.6	4.2	10.2	5.9	76.1				
6	14.6	11.6	4.7	9.5	5.9	76.0	15.1	10.7	4.4	10.3	6.0	76.1				
7	14.0	11.3	4.5	9.5	5.9	76.0	14.5	10.6	4.4	10.3	6.0	76.1				
8	14.1	11.1	4.7	9.5	5.9	76.0	14.7	10.9	4.8	10.5	6.0	76.1				
Mean	13.8	11.4	4.6	9.5	5.6	76.0	14.8	10.7	4.3	10.2	5.9	76.1				

Table C74 – Weld Measurements for Specimen T25-2 (E70T-7(H)W 12.7 mm)

Meas. Number	Before Failure										After Failure					
	Front Face					Back Face					Failure Face		Failure Face			
	Shear Leg (mm)	Tension Leg (mm)	45° Measurements			Weld Length (mm)	Shear Leg (mm)	Tension Leg (mm)	45° Measurements			Weld Length (mm)	Shear Leg After Fracture (mm)	Fracture Surface (mm)	Weld Root Penetration (mm)	Fracture Angle (°)
			Upper (mm)	Throat (mm)	Lower (mm)				Upper (mm)	Throat (mm)	Lower (mm)					
1	12.4	11.4	4.4	9.4	4.9	76.0	12.9	11.1	4.4	9.4	4.9	76.1	15.9	15.9	3.5	0
2	12.5	11.5	4.4	9.2	4.9	76.0	12.2	11.2	4.5	9.4	4.9	76.1	15.6	15.6	3.1	0
3	12.8	11.6	4.4	9.0	4.9	76.1	12.2	11.1	4.7	9.4	4.9	76.1	15.7	15.7	2.8	0
4	12.8	11.7	4.4	9.0	4.9	76.0	12.4	11.9	4.8	9.5	4.9	76.2	15.4	15.4	2.6	0
5	12.4	11.9	4.5	8.7	4.6	76.0	12.8	11.5	4.7	9.5	5.1	76.1	15.4	15.4	3.0	0
6	12.2	11.9	4.7	9.0	4.6	76.0	12.7	11.3	4.7	9.5	4.9	76.1	14.8	14.8	2.6	0
7	11.8	12.3	4.8	9.2	4.8	76.0	12.6	11.8	4.8	9.4	4.8	76.1	15.0	15.0	3.2	0
8	11.5	12.1	4.8	9.2	4.8	76.0	11.9	11.7	4.8	9.4	4.8	76.1	14.5	14.5	2.9	0
Mean	12.3	11.8	4.5	9.1	4.8	76.0	12.4	11.4	4.7	9.4	4.9	76.1	15.3	15.3	3.0	0

Table C75 – Weld Measurements for Specimen T25-3 (E70T-7(H)W 12.7 mm)

Meas. Number	Before Failure										After Failure					
	Front Face					Back Face					Failure Face		Failure Face			
	Shear Leg (mm)	Tension Leg (mm)	45° Measurements		Weld Length (mm)	Shear Leg (mm)	Tension Leg (mm)	45° Measurements		Weld Length (mm)	Shear Leg After Fracture (mm)	Fracture Surface (mm)	Weld Root Penetration (mm)	Fracture Angle (°)		
			Upper (mm)	Throat (mm)				Lower (mm)	Upper (mm)						Throat (mm)	Lower (mm)
1	13.5	11.5	4.8	9.5	5.1	75.9	11.9	11.3	4.5	9.8	4.4	76.0	14.5	14.5	2.6	0
2	13.8	11.8	4.8	9.5	5.2	75.9	12.1	11.3	4.4	9.5	4.4	76.1	14.2	14.2	2.2	0
3	13.9	11.5	4.5	9.5	5.2	76.0	12.9	10.9	4.4	9.5	5.1	76.0	15.0	15.0	2.1	0
4	13.6	11.2	4.4	9.5	5.2	75.9	13.8	11.1	4.4	9.5	5.4	76.0	15.9	15.9	2.1	0
5	14.0	11.3	4.7	9.7	5.2	76.0	14.1	10.4	4.2	9.5	5.4	76.0	16.3	10.4	2.2	24
6	13.2	11.6	5.0	9.8	5.2	76.0	13.8	10.6	4.2	9.5	5.6	76.0	16.1	10.6	2.3	22
7	13.5	12.2	5.3	9.8	5.4	76.0	13.8	11.0	4.2	9.5	5.4	76.0	16.3	10.4	2.5	23
8	14.1	12.3	5.1	10.0	5.2	75.9	14.1	10.8	4.0	9.4	5.4	76.0	16.6	10.7	2.5	23
Mean	13.7	11.7	4.8	9.7	5.2	75.9	13.3	10.9	4.3	9.5	5.1	76.0	15.6	12.7	2.3	11

Table C76 – Weld Measurements for Specimen T26-1 (E70T-7(H)S 12.7 mm)

Meas. Number	Before Failure										After Failure					
	Front Face					Back Face					Failure Face		Failure Face			
	Shear Leg (mm)	Tension Leg (mm)	45° Measurements		Weld Length (mm)	Shear Leg (mm)	Tension Leg (mm)	45° Measurements		Weld Length (mm)	Shear Leg After Fracture (mm)	Fracture Surface (mm)	Weld Root Penetration (mm)	Fracture Angle (°)		
			Upper (mm)	Throat (mm)				Lower (mm)	Upper (mm)						Throat (mm)	Lower (mm)
1	12.2	11.7	4.4	9.8	4.6	76.0	13.7	10.8	4.2	9.0	4.9	76.2	16.5	10.9	2.8	24
2	12.9	11.5	4.5	9.5	4.9	76.0	13.7	10.7	3.7	8.7	4.8	76.2	15.7	9.5	2.0	27
3	12.2	11.9	4.8	9.4	4.8	76.0	13.1	10.7	3.6	9.0	4.6	77.0	14.4	9.3	1.3	25
4	13.1	11.7	4.8	9.5	5.1	76.0	13.2	10.4	3.6	9.2	4.6	76.0	15.1	10.0	1.8	22
5	12.6	11.4	5.0	9.4	5.1	76.0	12.0	10.5	3.4	9.0	4.4	76.1	14.3	9.9	2.3	21
6	11.7	11.9	5.0	9.7	4.9	76.0	13.1	10.6	3.7	9.0	4.8	76.1	15.3	10.1	2.1	22
7	12.2	11.6	4.8	9.4	4.9	76.0	13.4	10.7	3.6	9.0	5.1	76.1	15.4	10.0	2.0	23
8	12.4	11.4	4.7	9.4	4.8	76.0	13.4	10.2	3.7	8.6	5.4	76.3	14.9	8.9	1.6	30
Mean	12.4	11.6	4.8	9.5	4.9	76.0	13.2	10.6	3.7	9.0	4.8	76.3	15.2	9.8	2.0	24

Table C77 – Weld Measurements for Specimen T26-2 (E70T-7(H)S 12.7 mm)

Meas. Number	Before Failure										After Failure				
	Front Face					Back Face					Failure Face		Failure Face		
	Shear Leg (mm)	Tension Leg (mm)	45° Measurements		Weld Length (mm)	Shear Leg (mm)	Tension Leg (mm)	45° Measurements		Weld Length (mm)	Shear Leg After Fracture (mm)	Fracture Surface (mm)	Weld Root Penetration (mm)	Fracture Angle (°)	
			Upper (mm)	Throat (mm)				Lower (mm)	Upper (mm)						Throat (mm)
1	11.5	11.6	4.8	9.5	75.9	12.6	11.3	4.5	9.4	5.1	76.2	15.1	11.7	3.6	23
2	12.9	11.9	4.8	9.4	75.9	13.0	11.2	4.5	9.2	5.1	76.1	16.7	11.7	3.8	23
3	13.0	12.0	5.0	9.4	75.9	12.4	10.9	4.2	9.0	4.9	76.1	16.8	11.4	3.8	23
4	11.2	11.5	4.8	9.5	76.0	11.7	11.0	4.0	9.0	4.3	76.2	14.7	11.6	3.5	23
5	12.7	12.2	5.0	9.7	75.9	13.0	10.8	4.2	9.2	4.8	76.2	15.4	11.1	2.8	23
6	13.5	12.2	5.0	9.5	75.9	12.4	11.3	4.5	9.4	4.6	76.2	17.3	11.7	3.8	22
7	12.3	11.9	4.8	9.7	75.9	12.9	11.5	4.5	9.4	4.8	76.2	14.9	11.3	2.6	23
8	12.3	11.7	4.8	9.5	75.9	13.6	11.7	4.5	9.2	5.1	76.1	15.1	11.3	2.9	21
Mean	12.4	11.9	4.9	9.5	75.9	12.7	11.2	4.4	9.2	4.8	76.1	15.8	11.4	3.3	23

Table C78 – Weld Measurements for Specimen T26-3 (E70T-7(H)S 12.7 mm)

Meas. Number	Before Failure										After Failure				
	Front Face					Back Face					Failure Face		Failure Face		
	Shear Leg (mm)	Tension Leg (mm)	45° Measurements		Weld Length (mm)	Shear Leg (mm)	Tension Leg (mm)	45° Measurements		Weld Length (mm)	Shear Leg After Fracture (mm)	Fracture Surface (mm)	Weld Root Penetration (mm)	Fracture Angle (°)	
			Upper (mm)	Throat (mm)				Lower (mm)	Upper (mm)						Throat (mm)
1	12.2	11.5	4.2	9.4	76.2	12.1	12.3	5.0	9.2	4.8	76.2	14.9	10.2	2.7	24
2	12.7	11.6	4.2	9.2	76.1	13.1	11.7	4.5	9.2	4.9	76.2	15.1	10.6	2.4	20
3	12.6	11.5	4.2	9.0	76.2	13.3	11.3	4.4	9.2	4.8	76.2	14.8	10.0	2.2	24
4	13.7	11.6	4.8	9.5	76.1	13.0	11.3	4.4	9.5	5.1	76.3	16.8	11.9	3.1	22
5	13.0	11.9	4.5	9.4	76.2	13.2	11.3	4.4	9.5	5.1	76.2	15.3	9.9	2.3	24
6	13.1	11.7	4.5	9.2	76.2	13.6	11.7	4.4	9.7	5.1	76.2	14.5	9.8	1.3	23
7	12.8	11.7	4.8	9.2	76.2	12.9	11.4	4.2	9.2	4.9	76.2	14.5	9.8	1.7	25
8	13.8	11.9	5.1	9.5	76.2	13.0	11.5	4.2	9.0	5.2	76.2	16.4	10.6	2.6	26
Mean	13.0	11.7	4.6	9.3	76.2	13.0	11.6	4.4	9.3	5.0	76.2	15.3	10.3	2.3	24

Table C79 – Weld Measurements for Specimen T27-1 (E70T-7(L)W 12.7 mm)

Meas. Number	Before Failure											After Failure				
	Front Face					Back Face						Failure Face				
	Shear Leg (mm)	Tension Leg (mm)	45° Measurements			Weld Length (mm)	Shear Leg (mm)	Tension Leg (mm)	45° Measurements			Weld Length (mm)	Fracture Surface (mm)	Weld Root Penetration (mm)	Fracture Angle (°)	
			Upper (mm)	Throat (mm)	Lower (mm)				Upper (mm)	Throat (mm)	Lower (mm)					
1	12.4	11.1	2.8	7.6	3.5	76.2	11.8	12.3	4.0	8.4	4.0	76.0	16.1	8.9	3.7	34
2	12.8	11.1	2.9	7.6	3.7	76.3	12.1	12.0	4.0	8.4	4.1	76.1	16.6	9.2	3.8	34
3	13.2	10.9	3.2	7.9	3.7	76.2	11.3	11.8	4.0	8.4	3.8	76.1	16.1	8.5	2.9	35
4	13.4	11.4	3.2	7.9	3.8	76.2	11.4	11.9	4.0	8.4	3.8	76.1	17.4	9.1	4.0	28
5	12.9	11.5	3.2	8.1	3.7	76.3	11.1	12.2	4.0	8.4	3.7	76.1	16.3	9.2	3.4	24
6	12.6	11.7	3.6	8.1	3.7	76.3	11.3	12.3	4.0	8.4	3.8	76.1	16.4	9.2	3.8	20
7	12.9	11.8	3.6	8.3	3.5	76.3	11.9	11.9	4.0	8.3	4.0	76.1	16.9	11.1	4.0	6
8	12.4	11.9	3.6	8.3	3.7	76.3	11.8	12.0	4.0	8.4	4.3	76.1	15.1	10.1	2.7	17
Mean	12.8	11.4	3.3	8.0	3.6	76.3	11.6	12.1	4.0	8.4	3.9	76.1	16.4	9.4	3.5	25

Table C80 – Weld Measurements for Specimen T27-2 (E70T-7(L)W 12.7 mm)

Meas. Number	Before Failure											After Failure				
	Front Face					Back Face						Failure Face				
	Shear Leg (mm)	Tension Leg (mm)	45° Measurements			Weld Length (mm)	Shear Leg (mm)	Tension Leg (mm)	45° Measurements			Weld Length (mm)	Fracture Surface (mm)	Weld Root Penetration (mm)	Fracture Angle (°)	
			Upper (mm)	Throat (mm)	Lower (mm)				Upper (mm)	Throat (mm)	Lower (mm)					
1	12.8	11.9	3.4	8.4	3.8	76.3	11.6	12.3	3.7	8.1	3.7	76.2	13.7	9.4	2.1	15
2	12.7	12.0	3.6	8.4	3.8	76.3	12.0	12.2	3.7	8.1	3.7	76.3	13.5	9.6	1.5	12
3	12.8	11.8	3.7	8.4	4.0	76.3	12.0	11.9	3.7	8.3	3.7	76.2	13.3	10.2	1.3	9
4	12.2	12.2	3.7	8.4	3.8	76.3	11.3	11.9	3.7	8.3	3.5	76.2	12.4	9.0	1.1	13
5	11.9	11.6	3.7	8.3	3.8	76.3	11.4	11.9	3.7	8.4	3.7	76.3	13.4	9.8	2.0	11
6	12.5	11.8	3.7	8.3	3.8	76.3	11.5	12.2	3.9	8.6	3.7	76.3	12.7	9.2	1.2	14
7	12.5	11.7	3.7	8.1	3.7	76.3	11.8	12.0	3.7	8.4	3.5	76.3	13.0	8.5	1.3	16
8	12.6	11.6	3.7	8.1	3.7	76.3	12.3	11.9	3.7	8.3	3.7	76.2	14.0	9.2	1.7	18
Mean	12.5	11.8	3.7	8.3	3.8	76.3	11.8	12.0	3.7	8.3	3.6	76.2	13.2	9.3	1.5	13

Table C81 – Weld Measurements for Specimen T27-3 (E70T-7(L)W 12.7 mm)

Meas. Number	Before Failure										After Failure			
	Front Face					Back Face					Failure Surface		Weld Root	
	Shear Leg (mm)	Tension Leg (mm)	45° Measurements		Weld Length (mm)	Shear Leg (mm)	Tension Leg (mm)	45° Measurements		Weld Length (mm)	Fracture Surface (mm)	Weld Penetration (mm)	Fracture Angle (°)	
			Upper (mm)	Throat (mm)				Lower (mm)	Upper (mm)					Throat (mm)
1	12.0	12.0	3.9	8.3	76.0	12.1	12.2	3.6	8.7	76.2	13.8	10.1	1.7	13
2	12.4	12.1	3.9	8.3	76.1	11.5	11.5	3.4	8.4	76.1	13.1	10.4	1.6	11
3	12.1	12.9	3.9	8.4	76.1	11.4	11.6	3.6	8.3	76.1	12.7	9.9	1.3	11
4	12.4	12.3	3.9	8.4	76.1	11.5	11.4	3.4	8.3	76.2	13.3	10.8	1.8	11
5	12.3	12.1	4.0	8.6	76.0	11.3	11.5	3.4	8.3	76.2	13.8	10.5	2.5	13
6	11.9	11.2	3.6	8.3	76.0	11.7	11.6	3.4	8.3	76.2	12.7	8.6	1.0	16
7	12.0	12.5	4.0	8.4	76.0	11.6	12.3	3.7	8.3	76.2	12.9	8.9	1.3	13
8	12.3	11.5	3.9	8.6	76.0	12.1	12.3	3.7	8.6	76.2	13.5	9.6	1.4	15
Mean	12.2	12.1	3.9	8.4	76.1	11.6	11.8	3.5	8.4	76.2	13.2	9.9	1.6	13

Table C82 – Weld Measurements for Specimen T28-1 (E70T-7(L)S 12.7 mm)

Meas. Number	Before Failure										After Failure			
	Front Face					Back Face					Failure Surface		Weld Root	
	Shear Leg (mm)	Tension Leg (mm)	45° Measurements		Weld Length (mm)	Shear Leg (mm)	Tension Leg (mm)	45° Measurements		Weld Length (mm)	Fracture Surface (mm)	Weld Penetration (mm)	Fracture Angle (°)	
			Upper (mm)	Throat (mm)				Lower (mm)	Upper (mm)					Throat (mm)
1	13.2	11.2	3.7	9.0	76.1	12.5	10.4	3.6	7.9	76.2	15.7	11.2	2.5	18
2	13.2	10.6	3.6	8.9	76.0	12.1	10.7	3.7	7.8	76.2	15.0	10.2	1.8	20
3	13.6	10.0	3.4	8.7	76.1	12.8	11.0	3.7	8.3	76.2	15.8	10.6	2.2	20
4	13.8	10.2	3.4	8.6	76.1	12.8	10.4	3.4	8.3	76.2	15.7	10.0	1.8	20
5	14.1	10.1	3.4	9.0	76.1	13.2	10.4	3.4	8.6	76.2	16.3	9.9	2.2	20
6	14.4	10.9	3.7	9.0	76.1	12.4	10.7	3.7	8.7	76.2	16.2	9.8	1.7	20
7	13.7	11.1	3.7	9.0	76.1	12.6	10.7	3.7	8.6	76.2	16.2	10.4	2.6	17
8	14.0	10.7	3.7	8.6	76.1	12.0	11.0	3.7	8.6	76.2	16.6	10.2	2.6	17
Mean	13.8	10.6	3.6	8.9	76.1	12.5	10.7	3.6	8.3	76.2	15.9	10.3	2.2	19

Table C83 – Weld Measurements for Specimen T28-2 (E70T-7(L)S 12.7 mm)

Meas. Number	Before Failure										After Failure					
	Front Face					Back Face					Failure Face		Failure Face			
	Shear Leg (mm)	Tension Leg (mm)	45° Measurements		Weld Length (mm)	Shear Leg (mm)	Tension Leg (mm)	45° Measurements		Weld Length (mm)	Shear Leg After Fracture (mm)	Fracture Surface (mm)	Weld Root Penetration (mm)	Fracture Angle (°)		
			Upper (mm)	Throat (mm)				Lower (mm)	Upper (mm)						Throat (mm)	Lower (mm)
1	13.5	10.4	3.7	8.7	5.1	76.2	12.5	11.1	4.0	8.7	4.0	76.1	15.1	15.1	2.6	0
2	13.9	10.3	3.7	8.7	4.9	76.2	12.4	11.2	4.0	8.4	4.1	76.1	15.2	15.2	2.8	0
3	13.4	10.6	3.7	9.0	4.8	76.2	12.2	11.1	3.9	8.3	4.1	76.1	14.4	14.4	2.3	0
4	13.1	10.6	3.7	9.2	4.9	76.2	12.1	10.8	3.6	8.1	4.0	76.1	15.0	15.0	2.9	0
5	13.4	10.6	3.9	9.2	5.1	76.2	12.5	10.2	3.4	7.8	4.0	76.1	14.8	14.8	2.3	0
6	13.2	11.0	4.4	9.2	5.4	76.2	12.3	10.2	3.4	8.3	4.3	76.1	14.8	14.8	2.5	0
7	12.8	10.9	4.4	9.5	5.1	76.2	12.1	11.0	3.6	8.6	4.0	76.1	14.7	14.7	2.6	0
8	12.8	11.1	4.4	9.2	4.9	76.2	11.9	10.8	3.6	8.4	4.3	76.1	15.0	15.0	3.1	0
Mean	13.3	10.7	4.0	9.1	5.0	76.2	12.2	10.8	3.7	8.3	4.1	76.1	14.9	14.9	2.6	0

Table C84 – Weld Measurements for Specimen T28-3 (E70T-7(L)S 12.7 mm)

Meas. Number	Before Failure										After Failure					
	Front Face					Back Face					Failure Face		Failure Face			
	Shear Leg (mm)	Tension Leg (mm)	45° Measurements		Weld Length (mm)	Shear Leg (mm)	Tension Leg (mm)	45° Measurements		Weld Length (mm)	Shear Leg After Fracture (mm)	Fracture Surface (mm)	Weld Root Penetration (mm)	Fracture Angle (°)		
			Upper (mm)	Throat (mm)				Lower (mm)	Upper (mm)						Throat (mm)	Lower (mm)
1	13.1	11.2	4.4	9.0	4.9	76.1	12.5	10.7	3.4	8.3	4.1	76.0	16.2	16.2	3.7	0
2	13.1	11.1	4.2	8.6	5.2	76.1	13.7	10.9	3.7	8.6	4.3	76.0	17.0	17.0	3.3	0
3	13.2	11.1	4.0	9.0	4.9	76.1	13.1	11.2	3.9	8.7	4.0	76.0	16.0	16.0	2.9	0
4	13.1	11.2	4.0	9.0	4.8	76.1	12.9	11.3	3.9	8.6	4.0	76.0	16.6	16.6	3.7	0
5	13.1	11.3	4.0	9.2	4.9	76.1	12.3	10.9	3.7	8.4	4.1	76.1	15.1	15.1	2.7	0
6	13.1	11.2	4.2	9.2	4.8	76.1	12.8	10.8	3.4	8.3	4.1	76.1	15.2	15.2	2.4	0
7	12.8	11.3	4.0	9.5	4.6	76.1	12.8	10.8	3.6	8.3	4.1	76.1	15.8	15.8	3.0	0
8	12.7	11.5	4.0	8.6	4.8	76.1	13.1	11.1	4.0	8.4	4.4	76.0	15.9	15.9	2.9	0
Mean	13.0	11.2	4.1	9.0	4.9	76.1	12.9	10.9	3.7	8.4	4.1	76.0	16.0	16.0	3.1	0

Table C85 – Weld Measurements for Specimen T29-1 (E70T7-K2(L)W 12.7 mm)

Meas. Number	Before Failure										After Failure					
	Front Face					Back Face					Failure Face		Failure Face			
	Shear Leg (mm)	Tension Leg (mm)	45° Measurements		Weld Length (mm)	Shear Leg (mm)	Tension Leg (mm)	45° Measurements		Weld Length (mm)	Shear Leg After Fracture (mm)	Fracture Surface (mm)	Weld Root Penetration (mm)	Fracture Angle (°)		
			Upper (mm)	Throat (mm)				Lower (mm)	Upper (mm)						Throat (mm)	Lower (mm)
1	11.3	12.1	5.0	10.0	4.3	76.2	15.5	12.1	4.5	9.2	5.6	76.1				
2	11.3	12.7	5.1	10.0	4.8	76.1	16.2	12.2	4.8	9.4	5.7	76.1				
3	12.5	12.3	5.0	10.2	5.2	76.1	16.4	12.7	5.0	9.5	5.9	76.1				
4	13.3	11.2	5.0	10.5	5.2	76.2	16.9	12.8	4.8	9.5	6.0	76.0				
5	13.2	11.5	5.3	10.6	5.2	76.1	16.3	12.8	5.0	9.4	5.7	76.1				
6	13.7	12.4	5.3	10.2	5.2	76.0	16.0	13.1	5.0	9.2	5.7	76.1				
7	13.4	12.2	5.3	10.0	5.1	76.0	16.3	12.6	4.5	9.0	5.7	76.1				
8	13.0	12.0	5.6	10.3	5.1	76.1	16.5	12.8	5.0	8.9	5.7	76.1				
Mean	12.7	12.0	5.2	10.2	5.0	76.1	16.3	12.6	4.8	9.3	5.8	76.1				

Table C86 – Weld Measurements for Specimen T29-2 (E70T7-K2(L)W 12.7 mm)

Meas. Number	Before Failure										After Failure					
	Front Face					Back Face					Failure Face		Failure Face			
	Shear Leg (mm)	Tension Leg (mm)	45° Measurements		Weld Length (mm)	Shear Leg (mm)	Tension Leg (mm)	45° Measurements		Weld Length (mm)	Shear Leg After Fracture (mm)	Fracture Surface (mm)	Weld Root Penetration (mm)	Fracture Angle (°)		
			Upper (mm)	Throat (mm)				Lower (mm)	Upper (mm)						Throat (mm)	Lower (mm)
1	13.2	13.0	5.5	10.3	5.2	76.0	17.1	12.2	4.7	9.4	5.7	76.2				
2	13.6	12.8	5.5	10.5	5.1	76.0	17.2	12.3	4.8	9.4	5.7	76.2				
3	13.9	12.5	5.6	10.5	5.2	76.1	17.3	12.3	4.5	9.4	5.9	76.1				
4	13.3	13.0	5.3	10.3	5.1	76.0	17.2	12.2	4.5	9.4	5.7	76.1				
5	13.0	12.6	5.3	10.2	5.1	76.0	16.3	12.2	4.5	9.4	5.7	76.1				
6	13.2	12.6	5.3	10.0	4.9	76.0	16.4	12.3	4.5	9.2	5.6	76.1				
7	13.4	12.7	5.8	10.3	5.1	76.0	16.3	12.0	4.5	9.2	5.6	76.1				
8	13.6	13.5	5.8	10.6	5.2	76.0	16.4	12.3	4.7	9.2	5.6	76.1				
Mean	13.4	12.8	5.5	10.3	5.1	76.0	16.8	12.2	4.6	9.3	5.7	76.1				

Table C87 – Weld Measurements for Specimen T29-3 (E70T7-K2(L)W 12.7 mm)

Meas. Number	Before Failure										After Failure					
	Front Face					Back Face					Failure Face		Failure Face			
	Shear Leg (mm)	Tension Leg (mm)	45° Measurements		Weld Length (mm)	Shear Leg (mm)	Tension Leg (mm)	45° Measurements		Weld Length (mm)	Shear Leg After Fracture (mm)	Fracture Surface (mm)	Weld Root Penetration (mm)	Fracture Angle (°)		
			Upper (mm)	Throat (mm)				Lower (mm)	Upper (mm)						Throat (mm)	Lower (mm)
1	16.0	10.8	4.0	9.4	6.0	76.0	13.1	13.6	6.3	11.0	5.2	76.1				
2	15.2	11.2	4.0	9.4	5.7	76.0	13.1	14.5	6.1	10.8	5.4	76.0				
3	15.9	12.1	5.0	9.8	5.9	76.0	13.4	13.7	5.9	10.5	5.4	76.1				
4	15.7	12.5	5.0	9.8	5.7	76.0	13.2	12.9	5.8	10.5	5.2	76.0				
5	16.0	12.3	5.0	9.8	5.9	76.0	13.4	13.1	6.1	10.8	5.4	76.0				
6	16.5	12.3	5.1	9.8	5.6	76.0	13.5	13.5	6.3	11.0	5.6	76.0				
7	16.4	12.4	5.0	9.7	5.9	76.0	13.5	13.9	6.1	10.6	5.6	76.0				
8	16.6	12.3	5.1	9.7	6.0	76.0	14.1	14.2	5.8	10.3	5.6	76.0				
Mean	16.0	12.0	4.8	9.7	5.8	76.0	13.4	13.7	6.0	10.7	5.4	76.0				

Table C88 – Weld Measurements for Specimen T30-1 (E70T7-K2(L)S 12.7 mm)

Meas. Number	Before Failure										After Failure					
	Front Face					Back Face					Failure Face		Failure Face			
	Shear Leg (mm)	Tension Leg (mm)	45° Measurements		Weld Length (mm)	Shear Leg (mm)	Tension Leg (mm)	45° Measurements		Weld Length (mm)	Shear Leg After Fracture (mm)	Fracture Surface (mm)	Weld Root Penetration (mm)	Fracture Angle (°)		
			Upper (mm)	Throat (mm)				Lower (mm)	Upper (mm)						Throat (mm)	Lower (mm)
1	13.2	11.9	4.0	9.4	4.6	76.2	12.6	9.6	2.9	8.4	4.8	76.2				
2	12.9	11.4	3.6	8.3	4.4	76.2	12.9	10.5	2.9	8.4	4.6	76.2				
3	13.3	10.6	3.2	8.6	4.4	76.2	13.0	9.9	3.2	8.6	4.6	76.2				
4	13.3	10.5	3.4	8.9	4.4	76.2	12.7	10.6	3.7	8.7	4.4	76.2				
5	13.3	10.7	4.0	8.9	4.6	76.2	12.7	10.7	3.7	8.7	4.6	76.3				
6	11.6	11.6	4.2	9.4	4.3	76.2	14.2	10.8	3.7	8.3	5.1	76.2				
7	11.4	11.7	4.0	8.9	4.3	76.2	13.4	10.3	3.4	8.4	4.9	76.2				
8	12.5	11.0	3.7	8.1	4.4	76.2	13.2	10.2	3.2	8.1	4.6	76.2				
Mean	12.7	11.2	3.8	8.8	4.4	76.2	13.1	10.3	3.4	8.5	4.7	76.2				

Table C89 – Weld Measurements for Specimen T30-2 (E70T7-K2(L)S 12.7 mm)

Meas. Number	Before Failure										After Failure				
	Front Face					Back Face					Failure Face		Failure Face		
	Shear Leg (mm)	Tension Leg (mm)	45° Measurements		Weld Length (mm)	Shear Leg (mm)	Tension Leg (mm)	45° Measurements		Weld Length (mm)	Shear Leg After Fracture (mm)	Fracture Surface (mm)	Weld Root Penetration (mm)	Fracture Angle (°)	
			Upper (mm)	Throat (mm)				Lower (mm)	Upper (mm)						Throat (mm)
1	12.8	11.6	4.0	8.9	76.1	14.1	9.1	2.4	8.1	4.6	76.0	16.4	10.8	2.3	64-45
2	12.9	9.9	3.4	9.2	76.1	14.1	9.9	2.9	7.9	4.4	76.0	15.9	8.7	1.8	19
3	11.7	10.4	3.4	8.9	76.1	14.7	9.7	2.9	8.3	4.4	76.0	16.2	9.8	1.6	19
4	12.8	10.3	3.4	8.6	76.1	13.7	9.4	2.9	8.7	4.8	76.1	16.2	10.6	2.5	19
5	13.1	11.0	3.7	9.0	76.1	13.1	9.5	2.6	8.9	4.6	76.0	15.4	10.4	2.2	19
6	13.4	10.3	3.1	8.4	76.1	12.6	9.6	3.2	8.4	4.3	76.0	15.0	9.5	2.4	19
7	12.4	9.6	2.8	8.4	76.1	13.1	10.1	3.4	8.9	4.4	76.0	16.0	10.4	2.9	19
8	11.9	9.8	2.9	8.7	76.1	14.0	9.8	3.2	9.0	4.4	76.0	17.2	11.5	3.2	18
Mean	12.6	10.3	3.3	8.8	76.1	13.7	9.6	3.0	8.5	4.5	76.0	16.0	10.2	2.4	19

Table C90 – Weld Measurements for Specimen T30-3 (E70T7-K2(L)S 12.7 mm)

Meas. Number	Before Failure										After Failure				
	Front Face					Back Face					Failure Face		Failure Face		
	Shear Leg (mm)	Tension Leg (mm)	45° Measurements		Weld Length (mm)	Shear Leg (mm)	Tension Leg (mm)	45° Measurements		Weld Length (mm)	Shear Leg After Fracture (mm)	Fracture Surface (mm)	Weld Root Penetration (mm)	Fracture Angle (°)	
			Upper (mm)	Throat (mm)				Lower (mm)	Upper (mm)						Throat (mm)
1	12.2	9.7	2.9	8.4	76.0	12.7	10.6	3.7	8.6	4.4	76.0	15.1	10.1	2.9	21
2	12.4	10.0	3.4	8.4	76.0	12.4	10.5	3.4	8.4	4.4	76.0	14.7	9.2	2.2	21
3	11.7	10.5	3.6	8.3	76.0	13.1	10.6	3.6	8.3	4.6	76.0	13.7	8.9	2.0	21
4	10.9	10.9	3.9	8.1	76.1	13.6	10.3	3.4	8.4	4.6	76.0	14.1	9.4	3.1	21
5	12.5	11.4	3.7	8.3	76.1	13.0	10.2	2.9	7.9	4.6	76.0	15.6	10.3	3.1	21
6	12.0	10.5	3.2	7.9	76.1	13.0	9.8	2.9	8.3	4.9	76.0	14.9	9.9	2.9	21
7	13.1	10.2	2.9	7.9	76.1	13.8	9.8	2.9	8.4	5.1	76.0	14.4	10.0	1.3	21
8	13.8	9.8	3.2	8.4	76.1	13.9	10.3	3.2	8.3	4.9	76.0	15.4	9.8	1.6	24
Mean	12.3	10.4	3.4	8.2	76.0	13.2	10.3	3.3	8.3	4.7	76.0	14.7	9.7	2.4	21

Table C91 – Weld Measurements for Specimen T31-1 (E71T8-K6(H)W 12.7 mm)

Meas. Number	Before Failure										After Failure			
	Front Face					Back Face					Failure Face		Failure Face	
	Shear Leg (mm)	Tension Leg (mm)	45° Measurements		Weld Length (mm)	Shear Leg (mm)	Tension Leg (mm)	45° Measurements		Weld Length (mm)	Shear Leg After Fracture (mm)	Fracture Surface (mm)	Weld Root Penetration (mm)	Fracture Angle (°)
			Upper (mm)	Throat (mm)				Lower (mm)	Upper (mm)					
1	11.2	10.8	3.7	7.8	4.0	76.1	10.4	11.8	9.8	4.3	76.2	14.4	4.0	0
2	11.3	10.7	3.9	9.0	3.8	76.1	10.1	12.8	5.0	4.1	76.2	14.5	4.4	0
3	11.4	10.7	3.7	8.7	4.3	76.1	10.5	12.0	4.8	4.0	76.3	14.1	3.7	0
4	12.4	10.1	3.7	8.9	4.3	76.1	10.4	12.5	4.8	4.6	76.3	15.3	5.0	0
5	11.8	10.4	3.7	8.6	4.3	76.1	10.1	12.2	4.7	4.3	76.2	13.8	3.8	0
6	11.5	10.3	4.0	8.7	4.3	76.1	9.8	12.6	4.8	4.0	76.2	14.5	4.7	0
7	11.1	11.1	4.2	9.0	4.3	76.1	11.1	12.4	5.0	4.4	76.2	15.1	4.0	0
8	11.2	11.7	4.4	9.0	4.3	76.1	12.0	12.6	5.0	4.8	76.2	15.3	11.9	14
Mean	11.5	10.7	3.9	8.7	4.2	76.1	10.5	12.4	4.9	4.3	76.2	14.6	5.2	2

Table C92 – Weld Measurements for Specimen T31-2 (E71T8-K6(H)W 12.7 mm)

Meas. Number	Before Failure										After Failure			
	Front Face					Back Face					Failure Face		Failure Face	
	Shear Leg (mm)	Tension Leg (mm)	45° Measurements		Weld Length (mm)	Shear Leg (mm)	Tension Leg (mm)	45° Measurements		Weld Length (mm)	Shear Leg After Fracture (mm)	Fracture Surface (mm)	Weld Root Penetration (mm)	Fracture Angle (°)
			Upper (mm)	Throat (mm)				Lower (mm)	Upper (mm)					
1	11.4	12.0	4.4	8.9	4.4	76.2	10.7	12.1	4.8	4.0	76.1	14.7	4.0	0
2	11.4	11.4	4.2	9.0	4.4	76.2	10.8	11.8	4.7	4.1	76.1	15.0	4.2	0
3	11.2	11.9	4.2	8.6	4.1	76.2	10.8	11.9	4.5	4.1	76.1	14.5	3.6	0
4	11.2	11.8	4.2	8.4	4.1	76.2	10.8	12.3	4.5	4.3	76.2	14.6	3.8	0
5	11.3	11.9	4.2	9.0	4.4	76.2	10.6	12.5	5.0	4.3	76.2	14.1	3.5	0
6	11.9	12.1	4.4	8.7	4.6	76.2	11.1	12.2	5.0	4.6	76.2	14.5	3.4	0
7	11.4	11.7	4.5	8.9	4.4	76.2	10.2	11.6	4.8	4.0	76.2	13.5	3.3	0
8	11.4	11.6	4.5	9.0	4.1	76.2	10.6	12.4	5.0	4.0	76.2	13.8	3.2	0
Mean	11.4	11.8	4.3	8.8	4.3	76.2	10.7	12.1	4.8	4.2	76.2	14.3	3.6	0

Table C93 – Weld Measurements for Specimen T31-3 (E71T8-K6(H)W 12.7 mm)

Meas. Number	Before Failure										After Failure				
	Front Face					Back Face					Failure Face		Failure Face		
	Shear Leg (mm)	Tension Leg (mm)	45° Measurements			Weld Length (mm)	Shear Leg (mm)	Tension Leg (mm)	45° Measurements			Fracture Surface (mm)	Weld Root Penetration (mm)	Fracture Angle (°)	
			Upper (mm)	Throat (mm)	Lower (mm)				Upper (mm)	Throat (mm)	Lower (mm)				
1	11.1	11.7	4.2	9.2	4.0	76.1	10.2	11.5	4.2	9.4	4.0	14.2	14.3	3.9	0
2	11.0	12.2	4.5	9.2	4.0	76.1	10.6	11.4	4.2	9.2	4.1	14.3	14.3	3.7	0
3	11.5	12.5	5.0	9.2	4.6	76.1	10.6	11.2	4.2	9.0	4.0	14.5	14.5	3.8	0
4	11.9	12.2	5.0	9.5	4.6	76.1	9.1	11.4	4.7	9.4	3.0	13.2	13.2	4.1	0
5	11.3	12.2	5.0	9.4	4.6	76.1	10.7	10.9	4.5	9.4	4.4	14.3	14.3	3.6	0
6	11.2	12.7	5.0	9.8	4.4	76.1	10.8	11.6	4.5	9.4	4.1	14.2	14.2	3.4	0
7	11.2	12.8	5.0	9.5	4.3	76.1	10.3	11.8	4.5	9.2	4.0	14.4	14.4	4.1	19
8	11.8	12.5	5.0	9.5	4.3	76.1	10.1	11.6	4.7	9.7	4.0	14.4	11.5	4.3	16
Mean	11.4	12.4	4.8	9.4	4.3	76.1	10.3	11.4	4.4	9.3	3.9	14.2	13.8	3.9	4

Table C94 – Weld Measurements for Specimen T32-1 (E71T8-K6(H)S 12.7 mm)

Meas. Number	Before Failure										After Failure				
	Front Face					Back Face					Failure Face		Failure Face		
	Shear Leg (mm)	Tension Leg (mm)	45° Measurements			Weld Length (mm)	Shear Leg (mm)	Tension Leg (mm)	45° Measurements			Fracture Surface (mm)	Weld Root Penetration (mm)	Fracture Angle (°)	
			Upper (mm)	Throat (mm)	Lower (mm)				Upper (mm)	Throat (mm)	Lower (mm)				
1	12.5	11.3	4.0	9.0	4.4	76.0	12.6	12.7	4.5	8.6	4.6	15.9	10.2	3.4	25
2	12.5	11.0	4.0	9.0	4.3	76.0	12.9	12.7	4.7	8.6	4.6	16.3	10.2	3.4	25
3	12.7	11.4	4.2	8.9	4.4	76.0	12.8	12.4	4.7	8.9	4.6	16.5	10.7	3.6	25
4	12.0	11.7	4.2	8.7	4.0	76.0	12.0	12.6	5.0	9.2	4.3	15.4	11.3	3.4	25
5	12.3	11.4	4.0	7.9	4.3	76.0	11.5	12.3	4.8	9.4	4.3	13.8	10.6	2.3	25
6	12.2	11.7	4.0	8.7	4.6	76.0	12.4	13.2	5.3	9.0	4.3	15.8	11.5	3.5	25
7	12.3	10.1	3.9	9.0	4.3	76.0	12.0	13.1	4.7	8.7	4.4	16.3	10.2	4.3	23
8	11.6	11.2	4.0	8.7	4.4	76.0	11.5	12.4	4.4	8.7	4.4	15.4	10.3	3.9	25
Mean	12.3	11.2	4.1	8.8	4.3	76.0	12.2	12.7	4.8	8.9	4.4	15.7	10.6	3.5	25

Table C95 – Weld Measurements for Specimen T32-2 (E71T8-K6(H)S 12.7 mm)

Meas. Number	Before Failure										After Failure					
	Front Face					Back Face					Failure Face		Failure Face			
	Shear Leg (mm)	Tension Leg (mm)	45° Measurements			Weld Length (mm)	Shear Leg (mm)	Tension Leg (mm)	45° Measurements			Weld Length (mm)	Shear Leg After Fracture (mm)	Fracture Surface (mm)	Weld Root Penetration (mm)	Fracture Angle (°)
			Upper (mm)	Throat (mm)	Lower (mm)				Upper (mm)	Throat (mm)	Lower (mm)					
1	12.1	11.8	4.0	8.9	4.6	76.0	12.1	12.6	4.5	9.4	4.8	76.1	15.0	10.7	2.9	21
2	11.1	11.6	4.4	9.0	4.6	76.1	11.8	11.9	4.5	9.4	4.4	76.1	14.6	10.5	2.8	21
3	12.1	11.5	4.0	9.0	4.8	76.1	12.7	12.2	4.5	9.2	4.8	76.1	15.9	10.7	3.2	21
4	11.4	10.4	4.2	9.4	4.6	76.1	11.7	13.6	4.7	8.9	4.6	76.1	15.1	10.5	3.4	22
5	10.8	12.4	4.7	9.4	4.6	76.1	13.0	12.7	5.0	9.2	4.8	76.1	16.3	10.5	3.3	22
6	11.1	11.8	4.8	9.7	4.6	76.1	11.7	12.3	5.0	9.2	4.8	76.1	15.1	10.2	3.4	23
7	11.1	11.7	4.7	8.7	4.6	76.1	11.8	12.7	4.8	8.6	4.9	76.1	15.3	9.8	3.5	26
8	11.3	12.3	4.7	8.6	4.4	76.1	11.7	13.2	4.8	8.4	4.6	76.1	15.0	8.7	3.3	31
Mean	11.4	11.7	4.4	9.1	4.6	76.1	12.1	12.7	4.7	9.0	4.7	76.1	15.3	10.2	3.2	23

Table C96 – Weld Measurements for Specimen T32-3 (E71T8-K6(H)S 12.7 mm)

Meas. Number	Before Failure										After Failure					
	Front Face					Back Face					Failure Face		Failure Face			
	Shear Leg (mm)	Tension Leg (mm)	45° Measurements			Weld Length (mm)	Shear Leg (mm)	Tension Leg (mm)	45° Measurements			Weld Length (mm)	Shear Leg After Fracture (mm)	Fracture Surface (mm)	Weld Root Penetration (mm)	Fracture Angle (°)
			Upper (mm)	Throat (mm)	Lower (mm)				Upper (mm)	Throat (mm)	Lower (mm)					
1	10.8	12.7	5.3	10.5	4.4	76.0	11.6	11.6	3.9	8.7	4.1	76.1	14.8	11.6	4.0	12
2	11.6	13.9	5.3	9.0	4.6	76.0	12.7	11.4	3.9	8.4	4.4	76.1	15.7	11.9	4.1	14
3	10.6	12.1	5.1	9.0	4.0	76.0	12.6	11.1	3.9	8.6	4.6	76.0	14.3	10.2	3.7	17
4	10.0	13.7	4.8	7.9	3.8	76.0	12.6	11.1	4.2	8.7	4.6	76.1	13.0	9.6	3.0	16
5	9.9	12.6	4.8	8.4	4.0	76.0	12.4	11.6	4.7	9.5	4.9	76.1	13.7	13.7	3.8	0
6	10.4	12.2	4.8	8.4	4.3	76.0	12.3	12.0	4.8	9.5	4.8	76.1	13.8	13.7	3.4	0
7	10.1	12.8	4.8	7.9	3.8	76.0	11.4	12.8	4.8	9.4	4.6	76.1	13.2	12.2	3.1	0
8	10.3	13.0	4.8	8.6	4.1	76.0	11.8	12.4	4.8	9.2	4.8	76.1	13.2	9.3	2.9	20
Mean	10.5	12.9	5.0	8.7	4.1	76.0	12.2	11.8	4.4	9.0	4.6	76.1	13.9	11.5	3.5	10

Table C97 – Weld Measurements for Specimen C1-1 (E70T-4(H)W 6.4 mm)

Meas. Number	Before Failure						After Failure			
	Front Face			Back Face			Fracture Surface (mm)	Fracture Angle (°)		
	Shear Leg (mm)	Tension Leg (mm)	45° Meas. (mm)	Weld Length (mm)	Shear Leg (mm)	Tension Leg (mm)			45° Meas. (mm)	Weld Length (mm)
1	6.9	5.3	3.7	75.6	7.8	5.9	4.9	75.5	7.9	0
2	7.3	5.0	3.7	75.6	7.8	5.5	4.9	75.5	8.1	0
3	6.7	4.8	3.7	75.5	8.3	6.2	5.1	75.6	7.4	0
4	7.3	5.4	3.7	75.5	8.0	6.4	4.8	75.5	7.9	0
5	7.5	5.3	4.0	75.6	7.6	6.0	4.8	75.6	7.6	0
6	7.1	5.5	3.8		7.5	6.2	4.8		7.5	0
7	7.7	4.9	3.7		8.0	6.3	4.9		6.7	32
8	6.8	4.9	3.7		7.4	6.6	4.8		7.6	90
Mean	7.2	5.1	5.5	75.5	7.8	6.1	5.6	75.5	7.6	15

Table C98 – Weld Measurements for Specimen C1-2 (E70T-4(H)W 6.4 mm)

Meas. Number	Before Failure						After Failure			
	Front Face			Back Face			Fracture Surface (mm)	Fracture Angle (°)		
	Shear Leg (mm)	Tension Leg (mm)	45° Meas. (mm)	Weld Length (mm)	Shear Leg (mm)	Tension Leg (mm)			45° Meas. (mm)	Weld Length (mm)
1	7.1	5.2	4.3	76.1	7.3	6.4	5.7	76.1	7.6	0
2	7.9	5.2	4.6	76.1	7.8	6.5	5.7	76.1	8.2	0
3	7.4	5.5	4.6	76.1	7.5	6.5	5.7	76.1	7.9	0
4	7.2	5.0	4.4	76.1	7.9	6.6	5.9	76.1	7.7	0
5	7.5	5.6	4.6	76.1	7.9	6.9	5.9	76.2	7.9	0
6	6.8	4.8	4.3		8.1	6.3	5.6		7.1	0
7	7.2	5.8	4.6		7.8	6.5	5.1		8.0	0
8	7.2	4.3	4.1		7.7	5.7	4.9		7.6	0
Mean	7.3	5.1	5.5	76.1	7.7	6.4	5.6	76.1	7.8	0

Table C99 – Weld Measurements for Specimen C1-3 (E70T-4(H)W 6.4 mm)

Meas. Number	Before Failure						After Failure			
	Front Face			Back Face			Fracture Surface (mm)	Fracture Angle (°)		
	Shear Leg (mm)	Tension Leg (mm)	45° Meas. (mm)	Weld Length (mm)	Shear Leg (mm)	Tension Leg (mm)				45° Meas. (mm)
1	7.4	5.7	4.6	75.0	8.6	7.4	6.0	75.2	7.9	0
2	7.0	5.2	4.6	74.9	7.4	6.1	5.2	75.1	7.3	0
3	6.7	5.8	4.6	75.0	8.1	5.6	5.4	75.1	7.3	0
4	7.2	5.6	4.4	74.9	8.2	6.4	5.7	75.0	7.2	0
5	6.1	5.3	4.4	75.1	7.7	5.9	5.6	75.0	6.4	0
6	6.6	5.5	4.6	75.1	7.3	6.8	5.4	75.0	6.6	0
7	6.0	5.5	4.4	75.0	7.0	6.3	5.6	75.0	6.3	0
8	6.3	5.5	4.1	75.0	7.7	6.4	5.6	75.0	6.3	0
Mean	6.7	5.5	5.5	75.0	7.7	6.4	5.6	75.1	6.9	0

Table C100 – Weld Measurements for Specimen C2-1 (E70T7-K2(L)W 6.4 mm)

Meas. Number	Before Failure						After Failure			
	Front Face			Back Face			Fracture Surface (mm)	Fracture Angle (°)		
	Shear Leg (mm)	Tension Leg (mm)	45° Meas. (mm)	Weld Length (mm)	Shear Leg (mm)	Tension Leg (mm)				45° Meas. (mm)
1	5.6	5.9	5.2	75.8	7.8	6.2	5.9	75.8	5.9	0
2	5.6	6.2	5.6	75.9	7.7	6.6	5.4	75.9	5.6	0
3	5.9	6.5	5.6	75.8	7.5	6.3	5.4	75.8	6.2	0
4	5.4	6.6	5.4	75.8	8.2	6.6	5.4	75.8	5.7	0
5	6.1	6.7	5.4	75.8	7.4	6.4	5.2	75.8	6.4	0
6	5.5	6.2	5.4	75.8	7.2	6.8	5.9	75.8	5.8	0
7	5.6	6.9	5.6	75.8	6.9	6.5	5.4	75.8	5.6	0
8	6.4	6.8	5.6	75.8	6.5	6.6	5.9	75.8	6.4	0
Mean	5.8	6.5	5.5	75.8	7.4	6.5	5.6	75.8	6.0	0

Table C101 – Weld Measurements for Specimen C2-2 (E70T7-K2(L)W 6.4 mm)

Meas. Number	Before Failure						After Failure				
	Front Face			Back Face			Fracture Surface (mm)	Fracture Angle (°)	Fracture Angle (°)		
	Shear Leg (mm)	Tension Leg (mm)	45° Meas. (mm)	Weld Length (mm)	Shear Leg (mm)	Tension Leg (mm)				45° Meas. (mm)	Weld Length (mm)
1	8.0	5.3	5.9	75.9	6.3	6.6	5.2	75.8	6.1	0	0
2	7.6	5.7	5.9	75.9	5.9	6.9	5.4	75.8	5.5	0	0
3	8.0	5.4	6.0	75.9	5.3	6.8	5.2	75.8	5.0	0	0
4	7.2	5.9	6.0	75.9	5.8	7.0	5.2	75.8	5.5	0	0
5	7.5	5.6	6.0	76.0	6.2	7.0	5.2	75.8	5.9	0	0
6	7.7	6.2	5.9	76.0	5.3	7.2	5.4	75.8	5.0	0	0
7	7.9	5.9	6.0	76.0	6.3	7.5	5.4	75.8	6.0	0	0
8	7.9	5.9	6.2	76.0	6.3	7.1	5.2	75.8	6.3	0	0
Mean	7.7	5.7	5.5	75.9	5.9	7.0	5.6	75.8	5.7	0	0

Table C102 – Weld Measurements for Specimen C2-3 (E70T7-K2(L)W 6.4 mm)

Meas. Number	Before Failure						After Failure				
	Front Face			Back Face			Fracture Surface (mm)	Fracture Angle (°)	Fracture Angle (°)		
	Shear Leg (mm)	Tension Leg (mm)	45° Meas. (mm)	Weld Length (mm)	Shear Leg (mm)	Tension Leg (mm)				45° Meas. (mm)	Weld Length (mm)
1	7.3	6.0	4.9	76.2	5.9	7.4	5.7	76.2	6.1	0	0
2	7.3	5.0	5.1	76.2	6.0	7.4	5.9	76.2	6.3	0	0
3	7.3	5.7	5.4	76.2	5.5	7.6	5.6	76.2	5.7	0	0
4	7.4	5.8	5.6	76.2	5.4	7.8	5.7	76.3	5.6	0	0
5	7.3	6.1	5.2	76.2	6.0	7.6	5.7	76.3	6.0	0	0
6	7.1	5.7	5.4	76.2	5.5	7.5	5.9	76.3	6.0	0	0
7	7.3	5.3	5.2	76.2	6.0	7.5	6.5	76.3	6.5	0	0
8	7.1	5.4	5.2	76.2	6.2	8.7	6.8	76.3	5.8	0	0
Mean	7.3	5.6	5.5	76.2	5.8	7.7	5.6	76.2	6.0	0	0

TABLE C103 – GAUGE LENGTHS FOR STRAIN MEASUREMENTS

Specimen Designation	Identifier	LVDT 1 (mm)	LVDT 2 (mm)	LVDT 3 (mm)	LVDT 4 (mm)
T1-1	E7014(L)W 6.4 mm	6.7	6.9	5.8	5.7
T1-2		6.8	6.1	5.6	6.4
T1-3		6.1	6.1	6.0	5.4
T2-1	E7014(L)W 6.4 mm	5.4	5.6	6.8	6.7
T2-2		5.9	6.3	5.8	6.2
T2-3		6.1	6.5	6.6	6.2
T3-1	E7014(L)W 6.4 mm	6.9	7.9	7.7	8.0
T3-2		8.0	7.7	7.6	8.4
T3-3		7.1	7.7	8.0	7.5
T4-1	E70T-4(H)W 6.4 mm	6.1	5.9	6.2	5.9
T4-2		5.9	6.0	6.3	6.5
T4-3		6.0	6.0	5.9	5.6
T5-1	E70T-4(H)W 6.4 mm	6.3	6.0	6.1	6.0
T5-2		6.1	6.3	6.2	6.1
T5-3		6.5	6.1	5.8	5.5
T6-1	E70T-4(H)W 6.4 mm	6.3	6.6	6.2	6.3
T6-2		6.7	6.4	6.6	6.9
T6-3		6.6	6.4	6.6	6.2
T7-1	E70T-4(H)S 6.4 mm	5.0	5.8	6.3	7.1
T7-2		4.6	5.8	6.6	5.1
T7-3		5.2	5.4	5.6	5.9
T8-1	E70T-4(L)W 6.4 mm	5.9	6.4	6.4	7.0
T8-2		6.7	6.0	7.0	6.9
T8-3		6.7	6.0	7.0	6.9
T9-1	E70T-4(L)S 6.4 mm	7.7	7.2	8.8	8.3
T9-2		8.0	8.5	7.9	8.9
T9-3		8.3	8.4	7.9	8.1
T10-1	E70T-4(L)S 6.4 mm	7.6	7.6	8.8	8.9
T10-2		8.3	7.8	8.4	7.8
T10-3		8.3	7.0	8.6	8.8
T11-1	E70T-7(H)W 6.4 mm	6.4	6.3	7.3	7.5
T11-2		6.4	6.8	7.0	7.3
T11-3		6.1	6.8	7.0	7.5
T12-1	E70T-7(H)S 6.4 mm	8.0	7.5	8.4	7.6
T12-2		8.1	8.3	8.2	7.9
T12-3		7.7	7.5	8.0	8.8
T13-1	E70T-7(L)W 6.4 mm	6.8	6.7	7.2	6.3
T13-2		6.2	6.4	7.3	7.3
T13-3		5.9	7.1	6.0	5.0
T14-1	E70T-7(L)S 6.4 mm	8.0	8.3	8.5	9.0
T14-2		8.1	8.6	9.0	8.4
T14-3		8.3	7.7	8.7	8.4
T15-1	E70T-7(L)S 6.4 mm	6.7	6.9	7.9	7.0
T15-2		7.3	7.2	7.6	7.6
T15-3		6.9	7.5	7.4	7.5

Table C103 – Gauge Lengths For Strain Measurements (Cont.)

Specimen Designation	Identifier	LVDT 1 (mm)	LVDT 2 (mm)	LVDT 3 (mm)	LVDT 4 (mm)
T16-1	E70T7-K2(L)W 6.4 mm	6.5	6.6	7.6	7.7
T16-2		6.5	6.6	8.1	8.1
T16-3		7.1	6.8	7.3	6.6
T17-1	E70T7-K2(L)S 6.4 mm	8.9	9.5	9.8	9.1
T17-2		9.4	9.7	9.0	10.0
T17-3		9.1	9.8	7.8	8.4
T18-1	E71T8-K6(H)W 6.4 mm	4.9	5.8	6.0	5.8
T18-2		4.8	5.3	5.4	5.0
T18-3		5.6	5.6	5.3	5.4
T19-1	E71T8-K6(H)S 6.4 mm	7.8	8.1	7.4	7.6
T19-2		9.2	8.4	7.9	7.6
T19-3		8.6	8.8	7.1	8.8
T20-1	E7014(L)W 12.7 mm	12.9	13.9	14.3	12.5
T20-2		13.2	12.6	13.6	13.6
T20-3		13.5	13.7	13.9	12.5
T21-1	E70T-4(H)W 12.7 mm	12.0	11.3	12.4	12.3
T21-2		12.0	12.4	11.8	12.1
T21-3		13.0	11.5	12.0	12.0
T22-1	E70T-4(H)S 12.7 mm	9.5	9.7	11.4	10.9
T22-2		10.5	10.2	10.5	11.1
T22-3		12.1	11.5	10.1	10.4
T23-1	E70T-4(L)W 12.7 mm	13.2	12.4	13.5	13.5
T23-2		12.7	12.3	13.0	13.3
T23-3		12.3	13.0	12.9	13.3
T24-1	E70T-4(L)S 12.7 mm	11.2	12.4	11.5	11.4
T24-2		12.3	12.9	12.1	11.7
T24-3		12.6	13.7	11.7	12.1
T25-1	E70T-7(H)W 12.7 mm	13.5	14.2	14.6	14.6
T25-2		12.7	12.1	12.2	12.3
T25-3		13.1	13.4	13.7	13.8
T26-1	E70T-7(H)S 12.7 mm	11.9	12.5	13.2	13.7
T26-2		12.4	12.9	12.7	12.8
T26-3		12.3	13.3	12.9	12.9
T27-1	E70T-7(L)W 12.7 mm	12.6	12.8	11.5	11.7
T27-2		12.8	12.7	11.8	12.0
T27-3		12.3	12.0	11.4	11.5
T28-1	E70T-7(L)S 12.7 mm	13.4	13.8	12.6	12.7
T28-2		13.7	12.9	12.2	12.4
T28-3		12.6	13.0	12.9	13.5
T29-1	E70T7-K2(L)W 12.7 mm	11.8	13.1	16.2	16.2
T29-2		13.7	13.3	17.1	16.4
T29-3		13.4	13.4	16.1	15.4
T30-1	E70T7-K2(L)S 12.7 mm	13.0	11.5	13.8	13.2
T30-2		12.9	12.6	13.0	14.6
T30-3		12.4	13.1	13.6	12.8

Table C103 – Gauge Lengths For Strain Measurements (Cont.)

Specimen Designation	Identifier	LVDT 1 (mm)	LVDT 2 (mm)	LVDT 3 (mm)	LVDT 4 (mm)
T31-1	E71T8-K6(H)W 12.7 mm	11.3	11.1	10.6	10.2
T31-2		10.9	11.3	10.3	10.4
T31-3		11.3	11.3	10.4	10.7
T32-1	E71T8-K6(H)S 12.7 mm	12.3	12.2	11.9	12.5
T32-2		11.4	11.0	12.0	12.4
T32-3		10.7	9.7	11.8	12.5
C1-1	E70T-4(H)W 6.4 mm	—	8.4	—	8.3
C1-2		—	7.7	—	7.8
C1-3		—	7.4	—	9.0
C2-1	E70T7-K2(L)W 6.4 mm	5.7	6.0	7.2	7.6
C2-2		—	7.8	—	8.1
C2-3		7.0	7.2	6.0	5.9

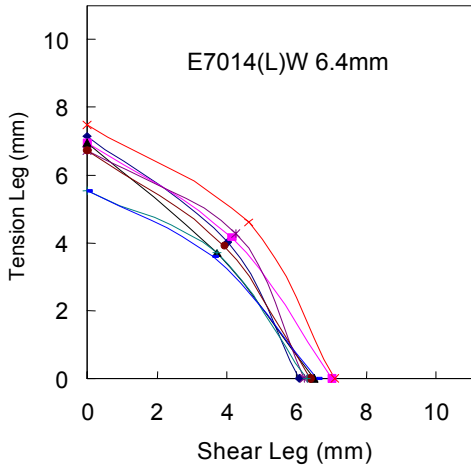

Figure C1 – Weld Profile for Specimen T1-1

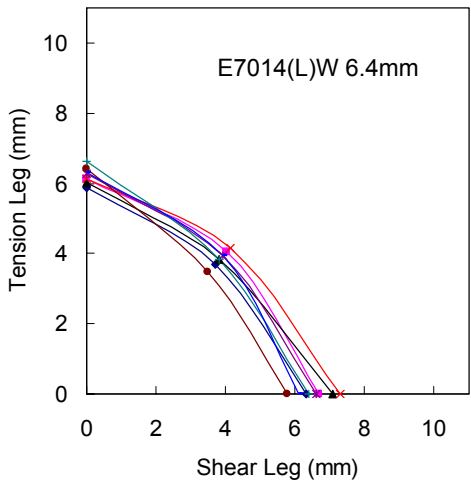
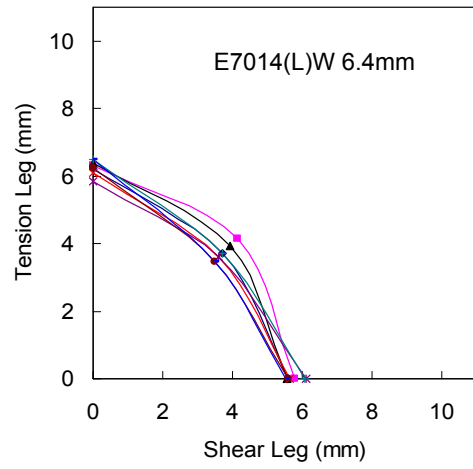

Figure C2 – Weld Profile for Specimen T1-2

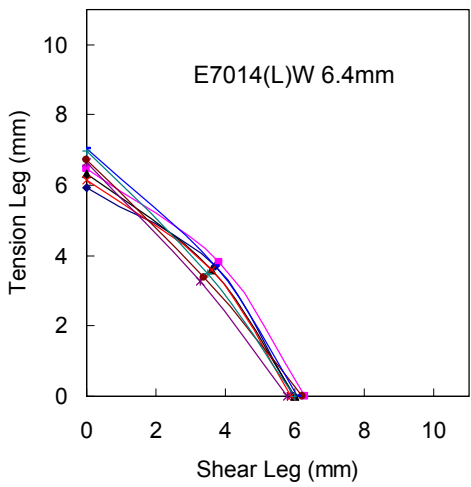
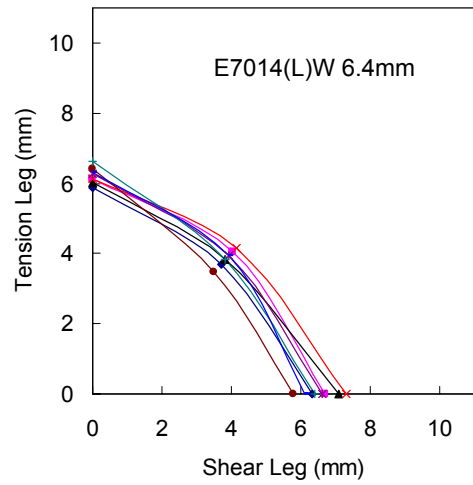
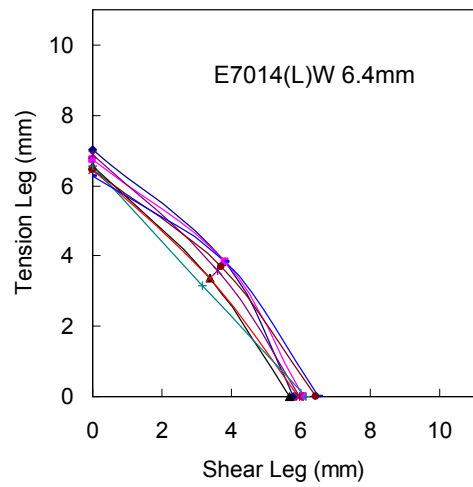

Figure C3 – Weld Profile for Specimen T1-3



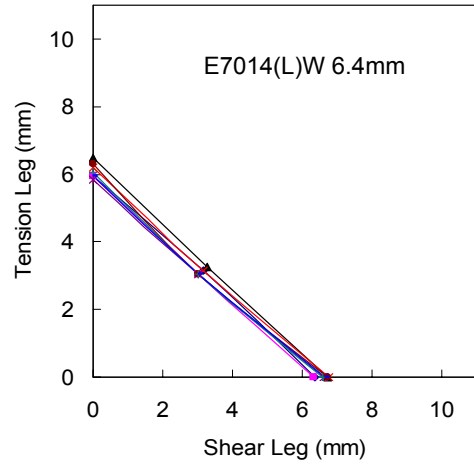
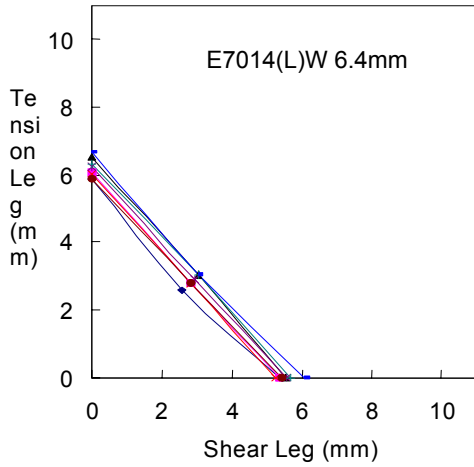

Figure C4 – Weld Profile for Specimen T2-1

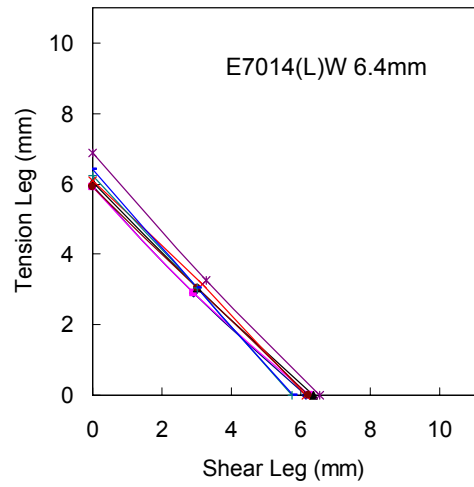
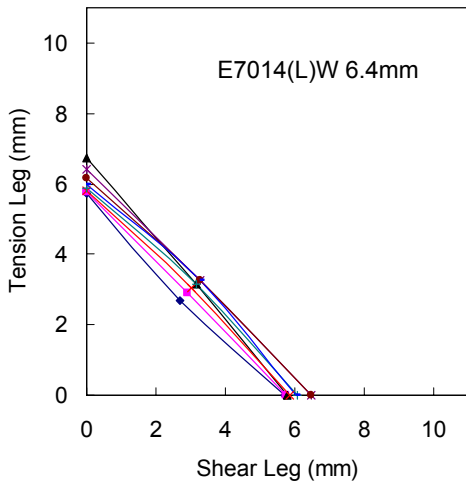

Figure C5 – Weld Profile for Specimen T2-2

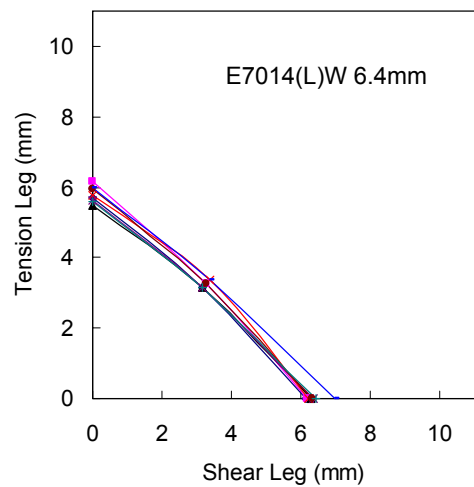
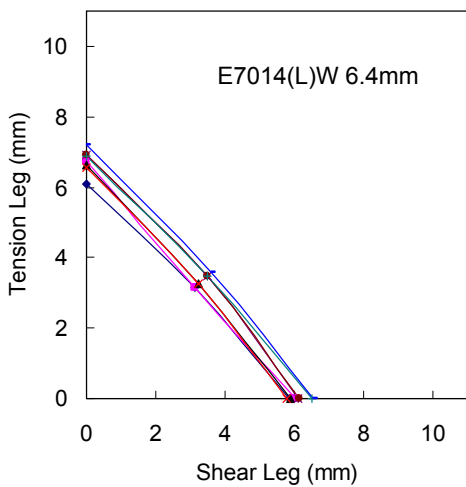

Figure C6 – Weld Profile for Specimen T2-3

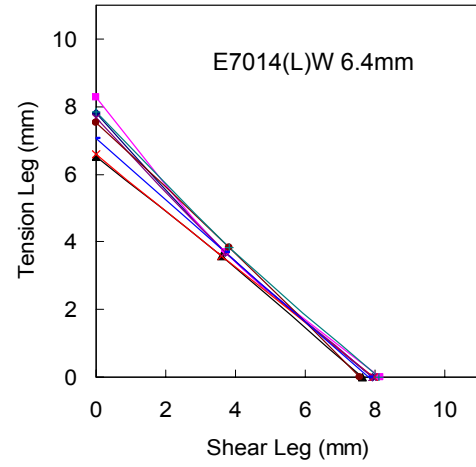
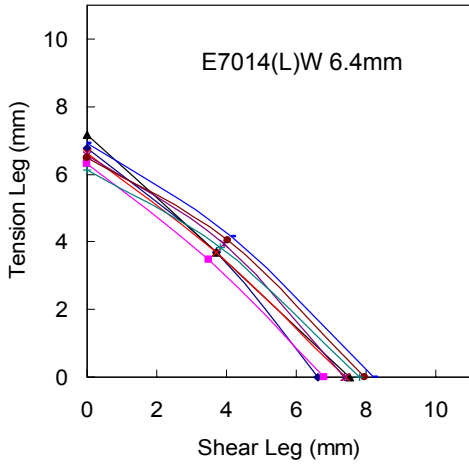

Figure C7 – Weld Profile for Specimen T3-1

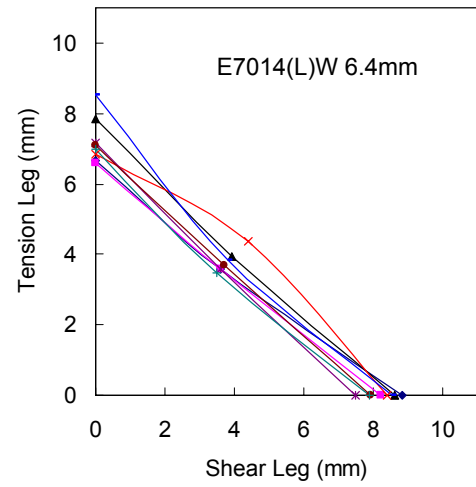
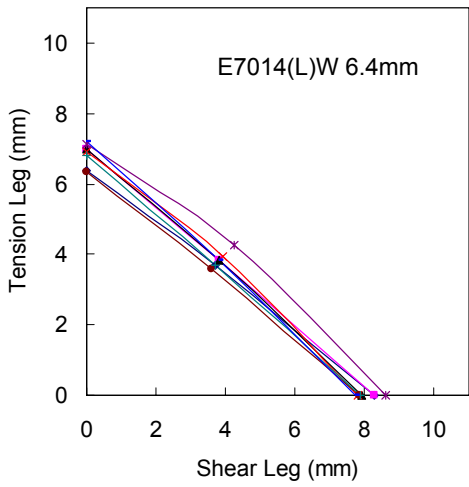

Figure C8 – Weld Profile for Specimen T3-2

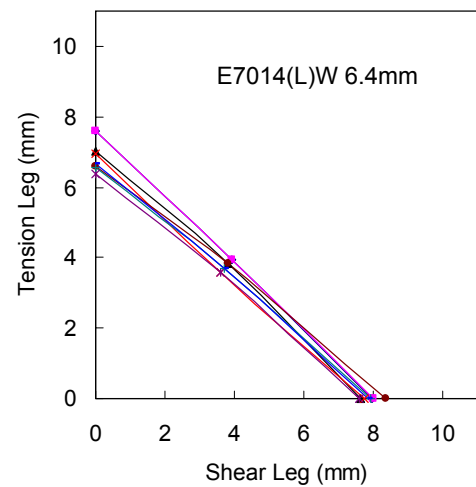
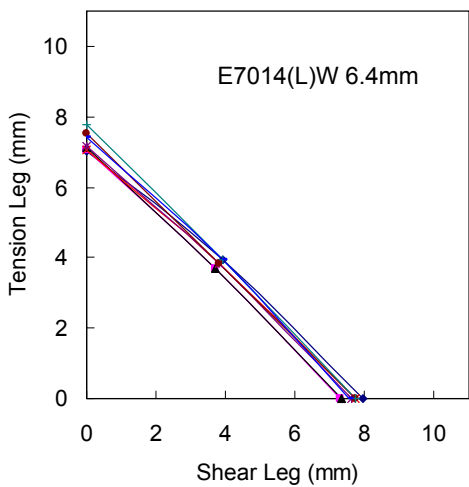

Figure C9 – Weld Profile for Specimen T3-3

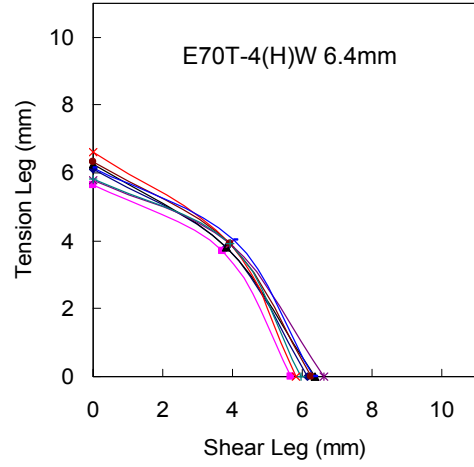
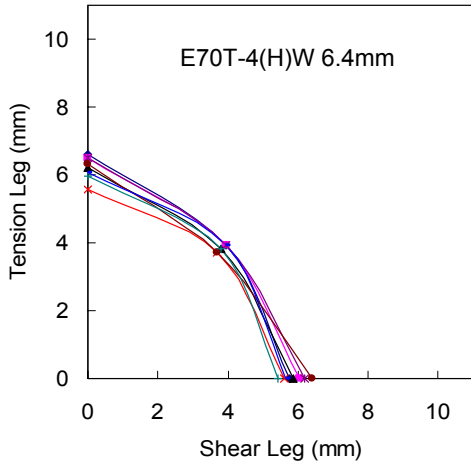

Figure C10 – Weld Profile for Specimen T4-1

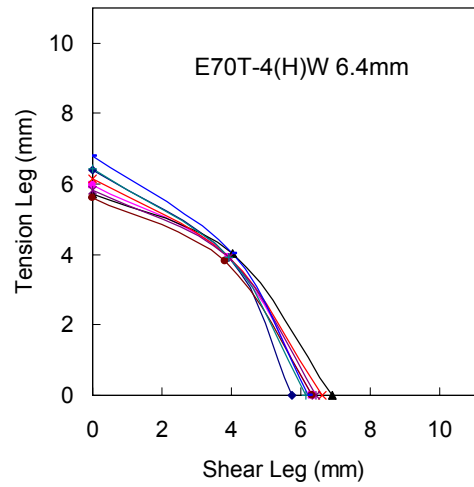
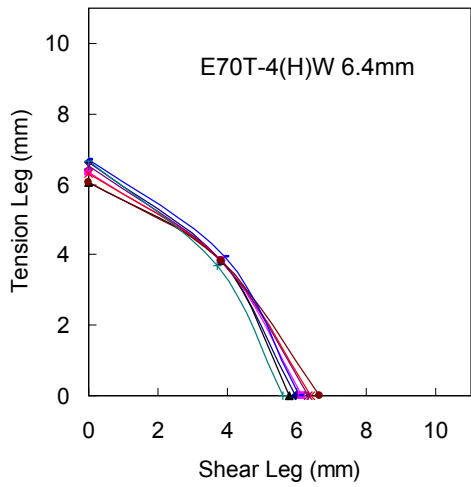

Figure C11 – Weld Profile for Specimen T4-2

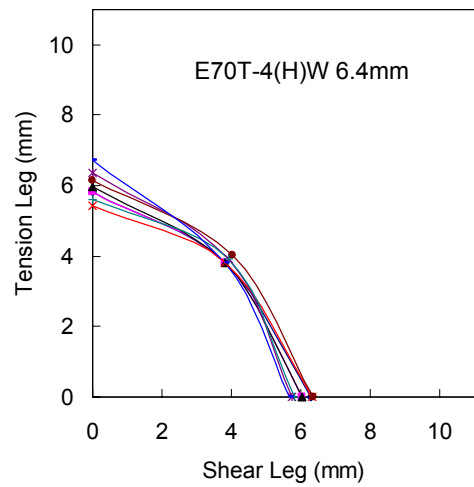
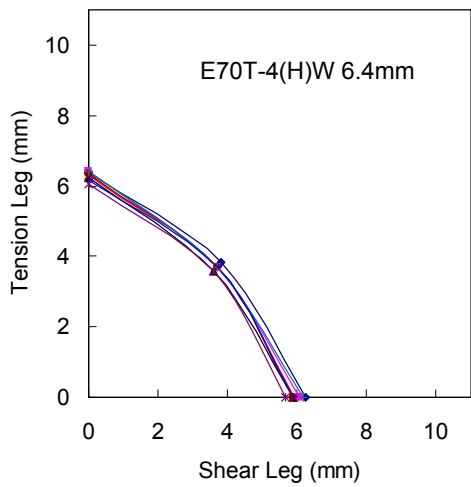

Figure C12 – Weld Profile for Specimen T4-3

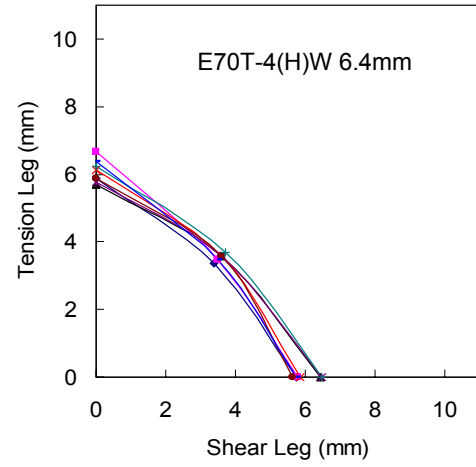
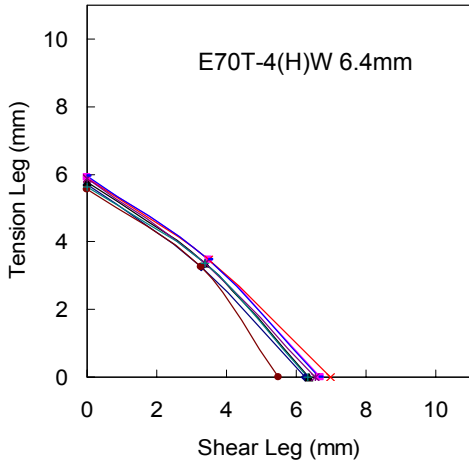

Figure C13 – Weld Profile for Specimen T5-1

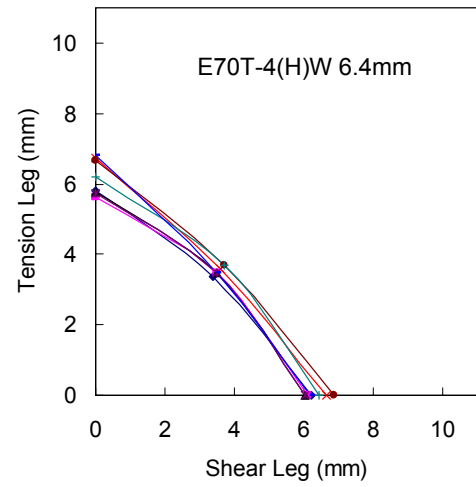
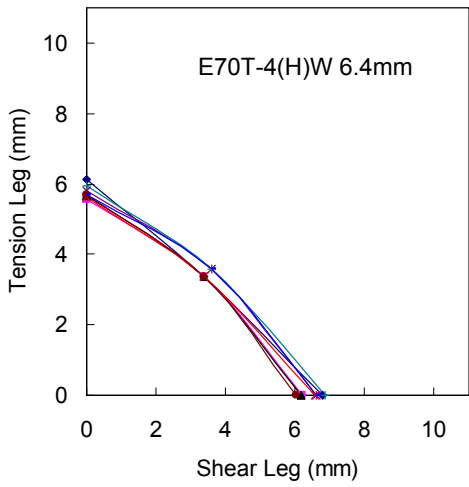

Figure C14 – Weld Profile for Specimen T5-2

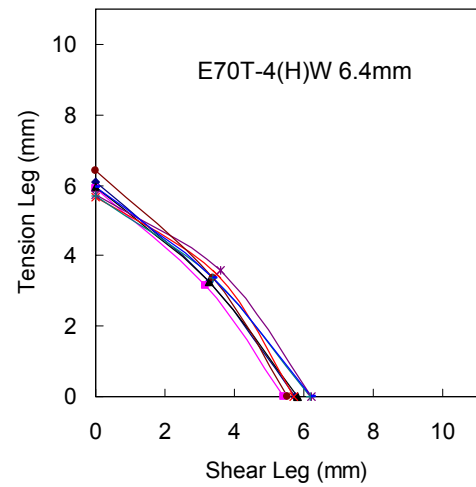
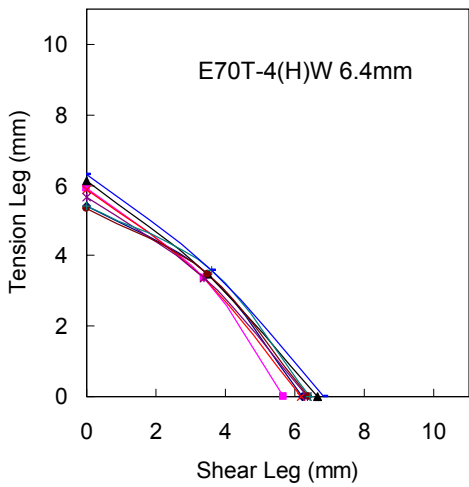

Figure C15 – Weld Profile for Specimen T5-3

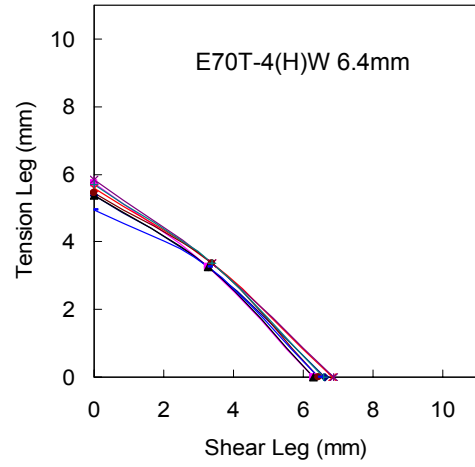
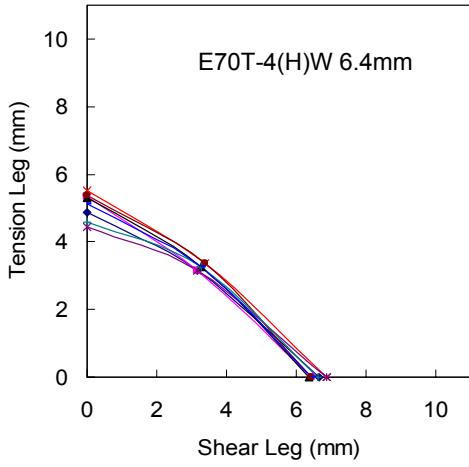

Figure C16 – Weld Profile for Specimen T6-1

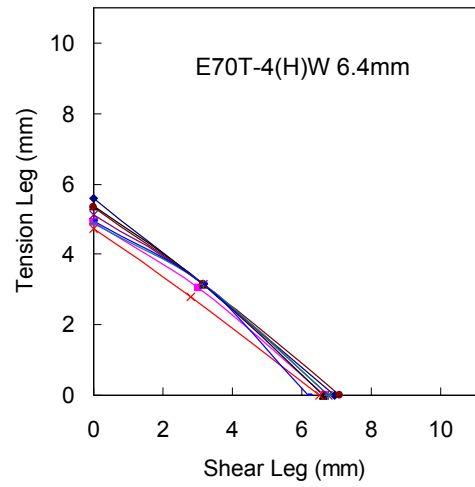
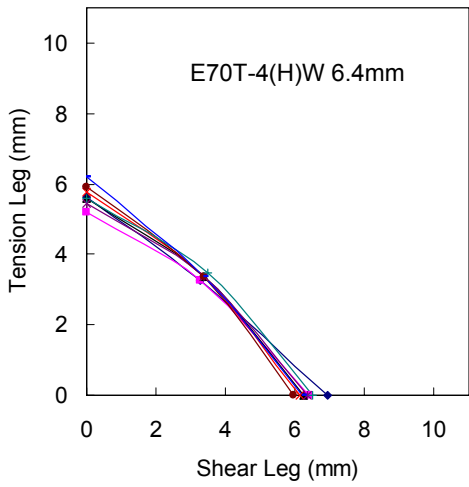

Figure C17 – Weld Profile for Specimen T6-2

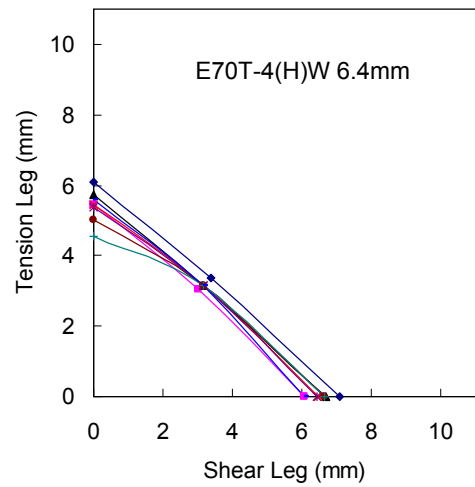
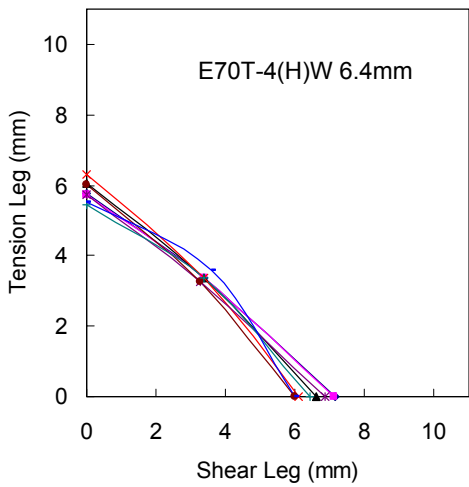

Figure C18 – Weld Profile for Specimen T6-3

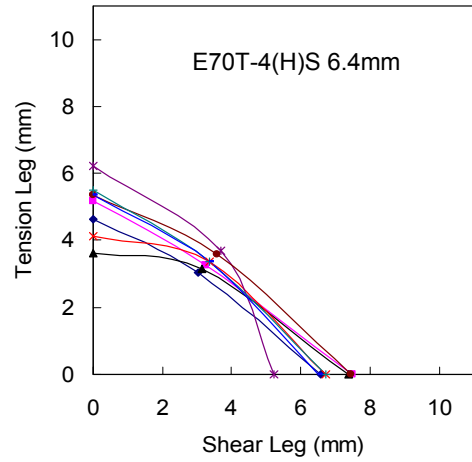
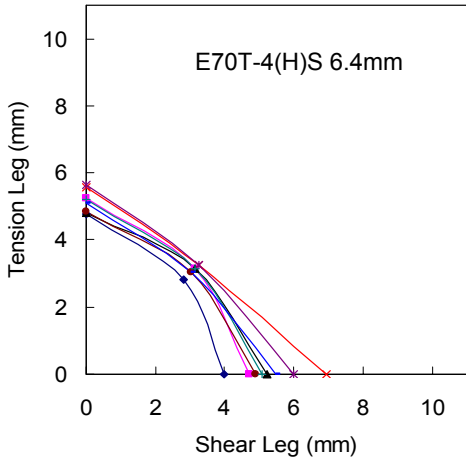

Figure C19 – Weld Profile for Specimen T7-1

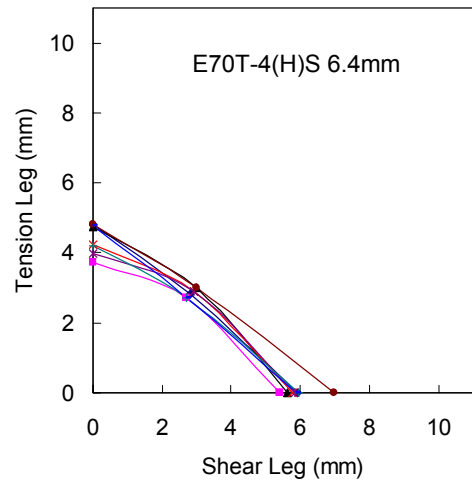
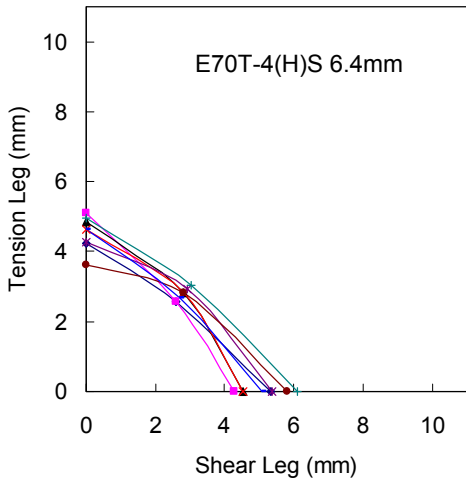

Figure C20 – Weld Profile for Specimen T7-2

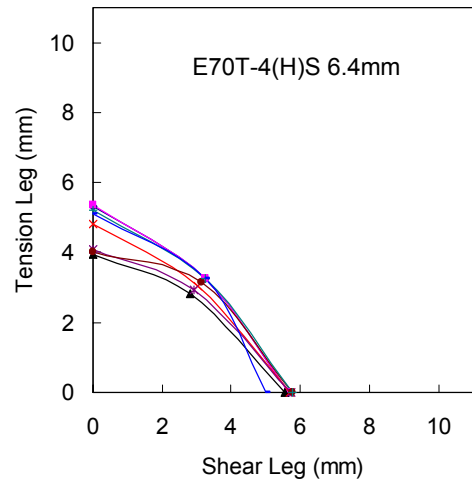
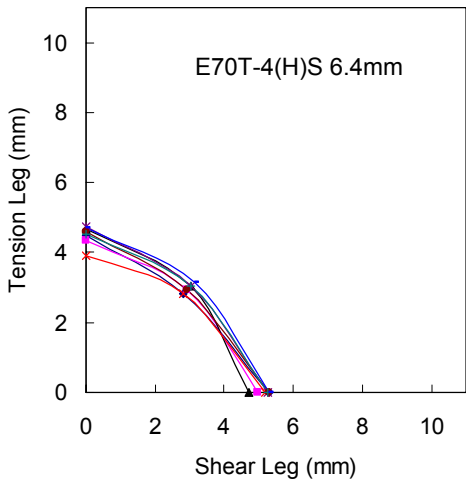

Figure C21 – Weld Profile for Specimen T7-3

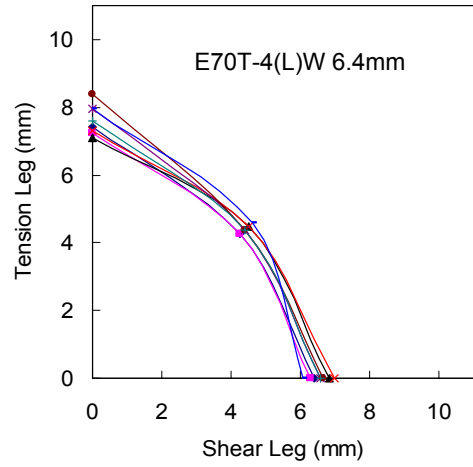
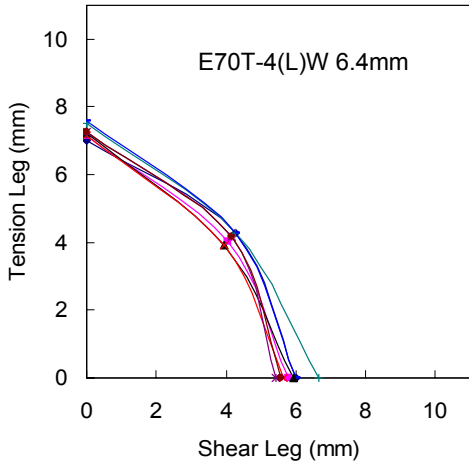

Figure C22 – Weld Profile for Specimen T8-1

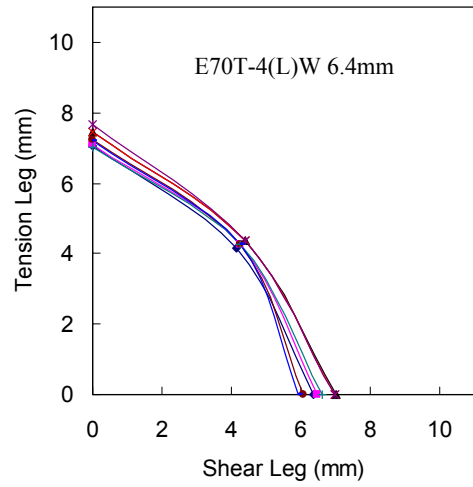
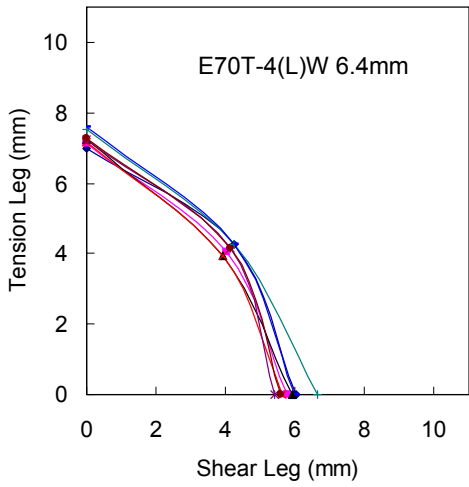

Figure C23 – Weld Profile for Specimen T8-2

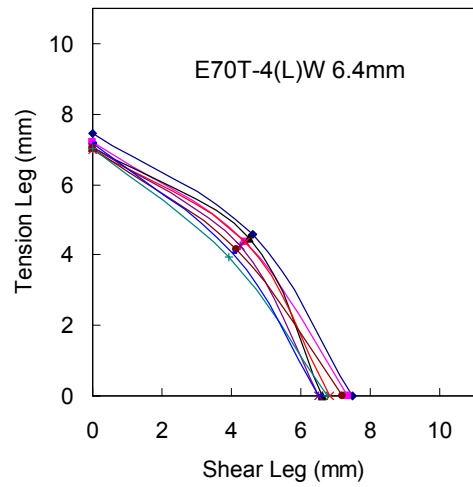
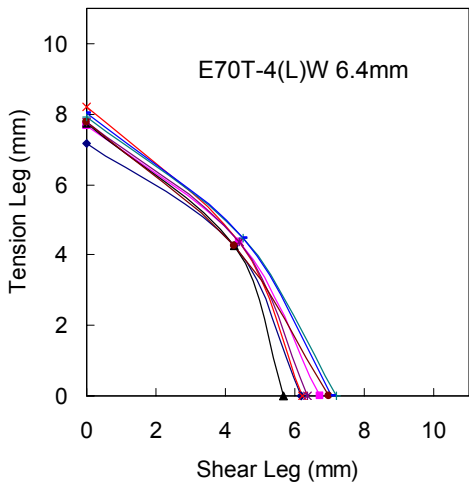

Figure C24 – Weld Profile for Specimen T8-3

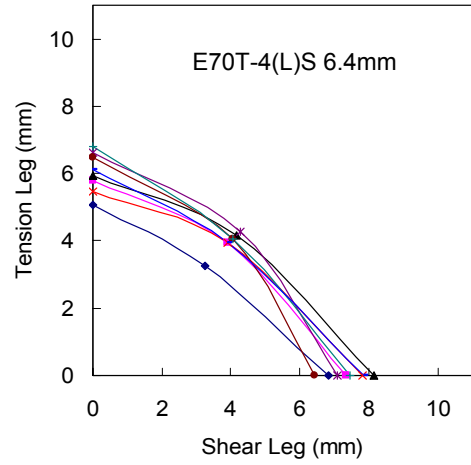
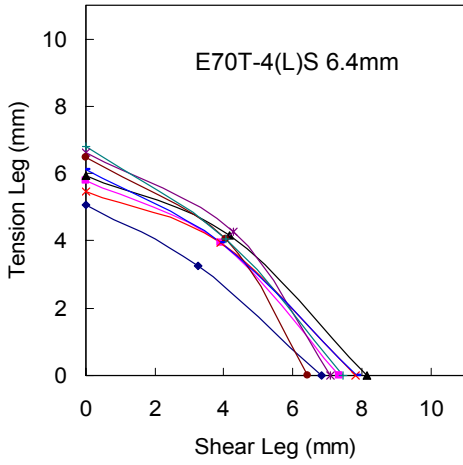

Figure C25 – Weld Profile for Specimen T9-1

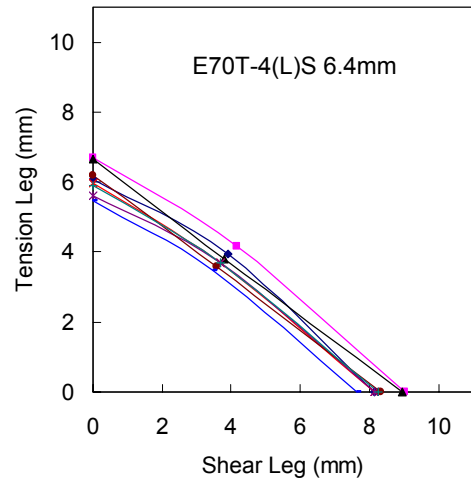
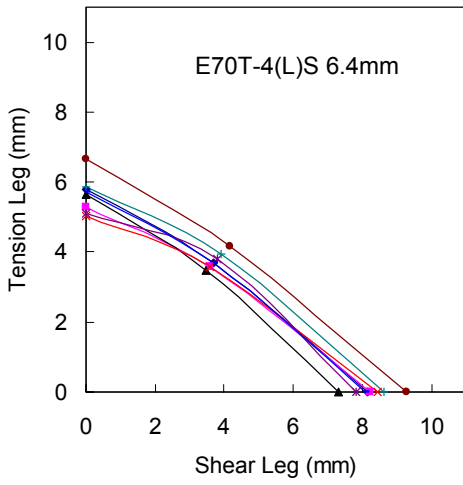

Figure C26 – Weld Profile for Specimen T9-2

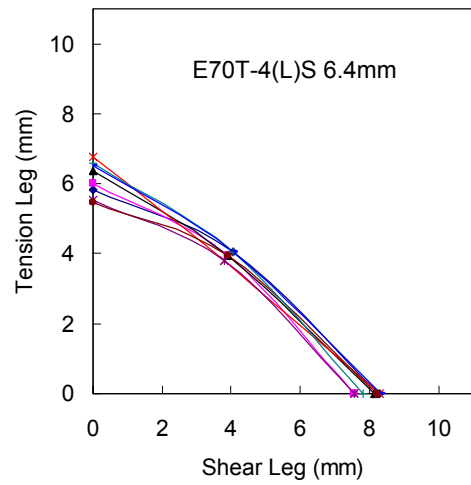
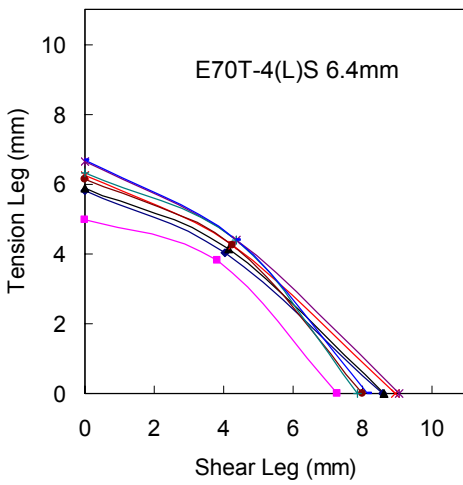

Figure C27 – Weld Profile for Specimen T9-3

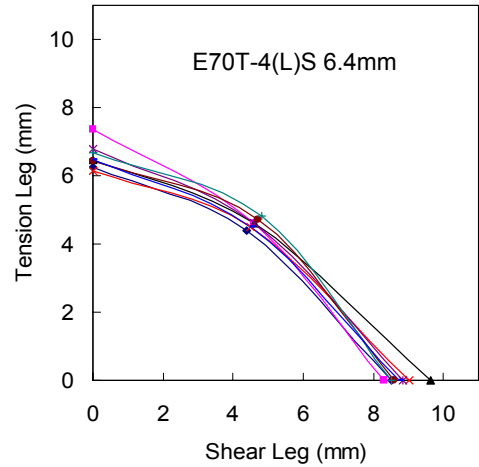
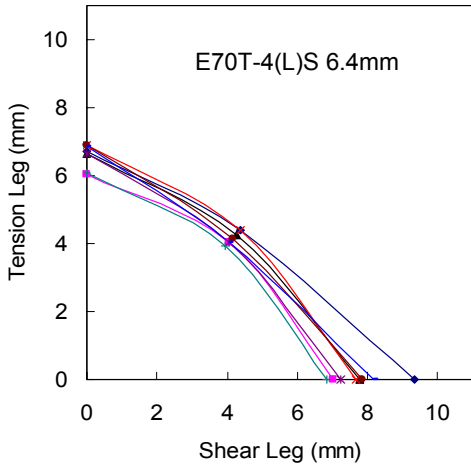

Figure C28 – Weld Profile for Specimen T10-1

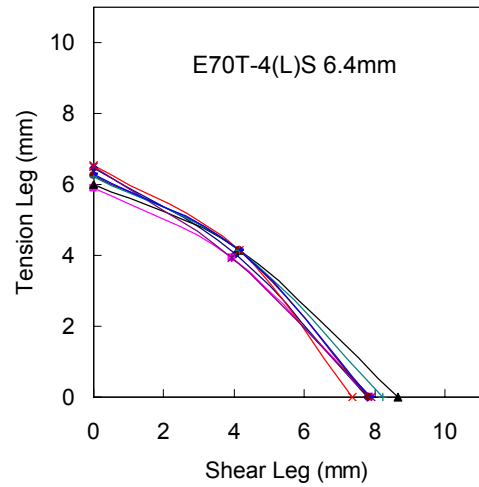
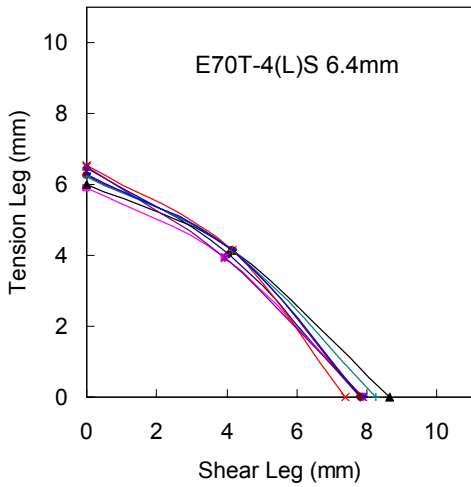

Figure C29 – Weld Profile for Specimen T10-2

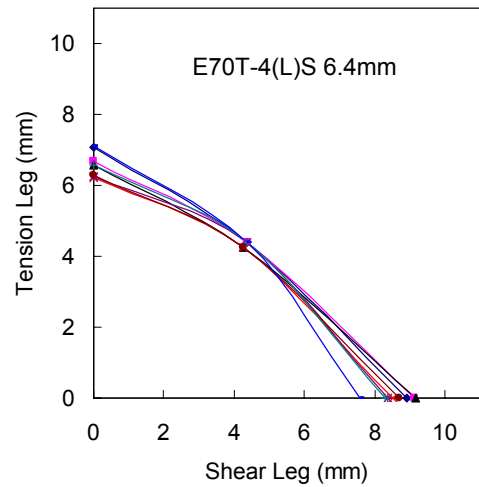
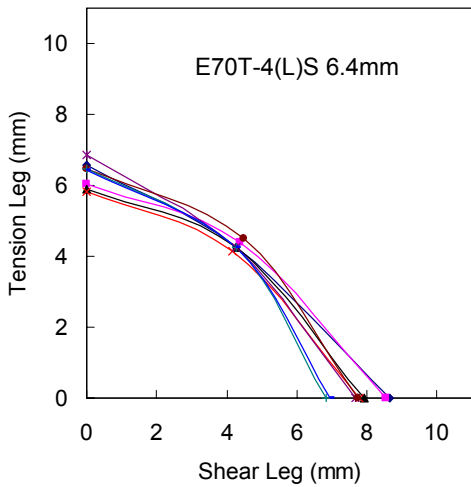

Figure C30 – Weld Profile for Specimen T10-3

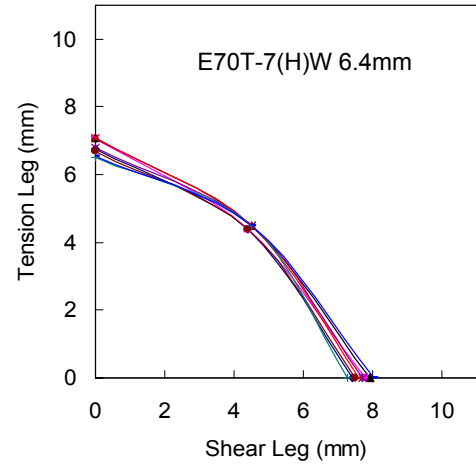
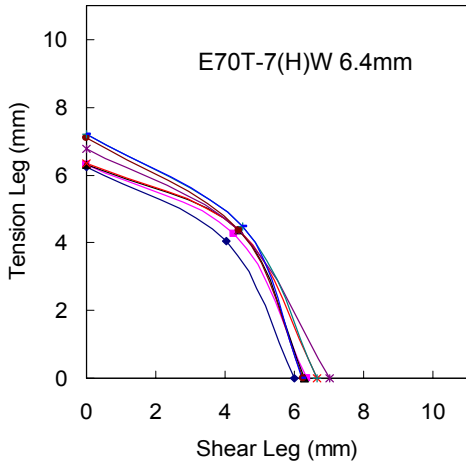

Figure C31 – Weld Profile for Specimen T11-1

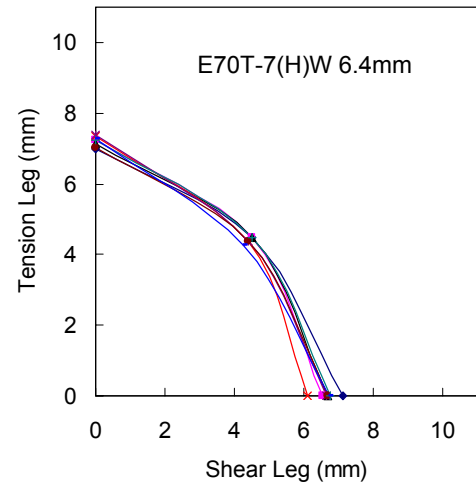
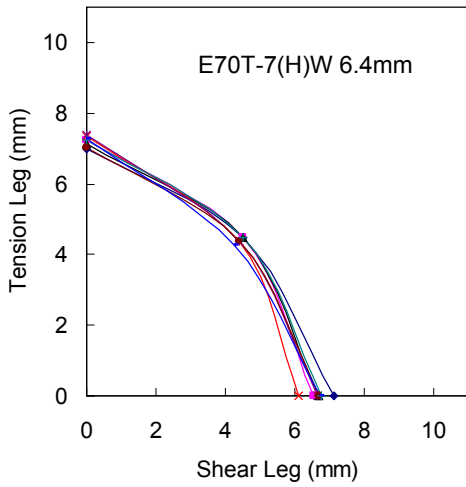

Figure C32 – Weld Profile for Specimen T11-2

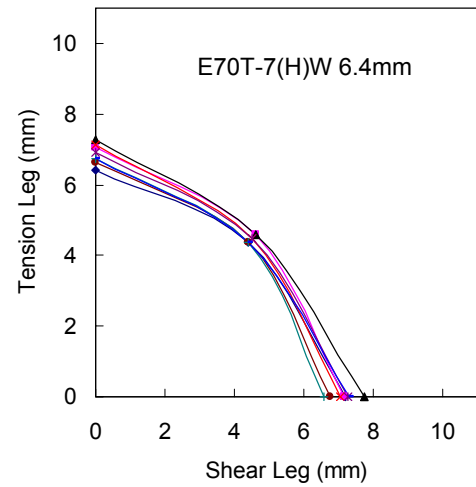
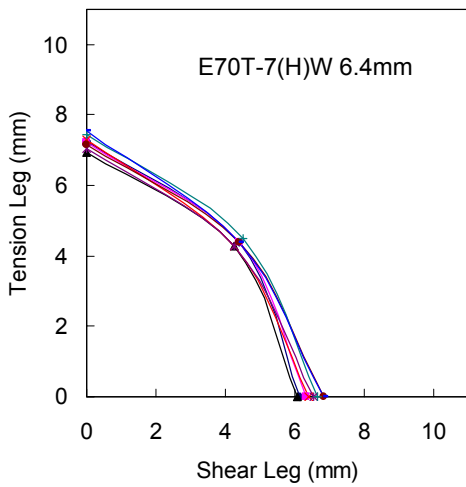

Figure C33 – Weld Profile for Specimen T11-3

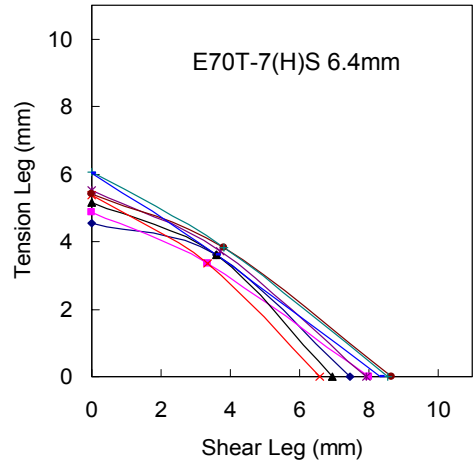
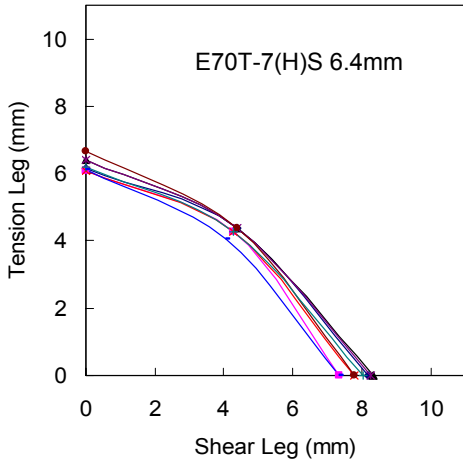

Figure C34 – Weld Profile for Specimen T12-1

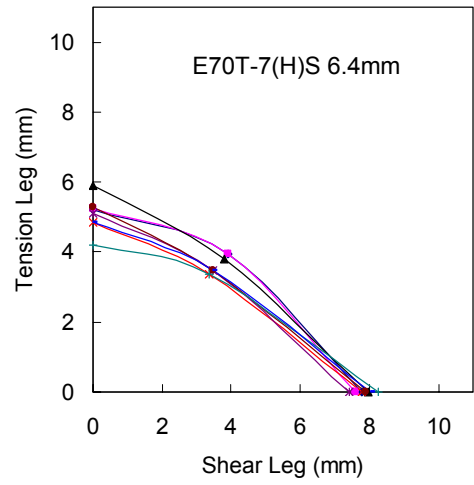
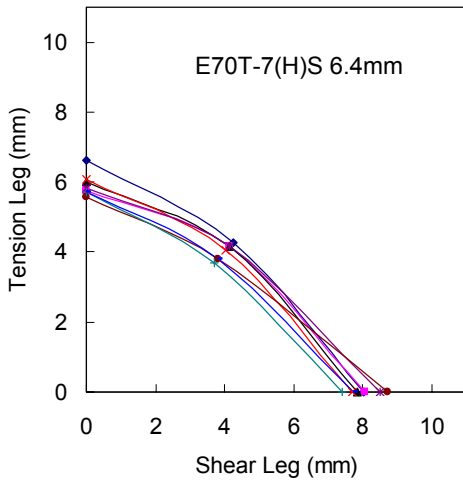

Figure C35 – Weld Profile for Specimen T12-2

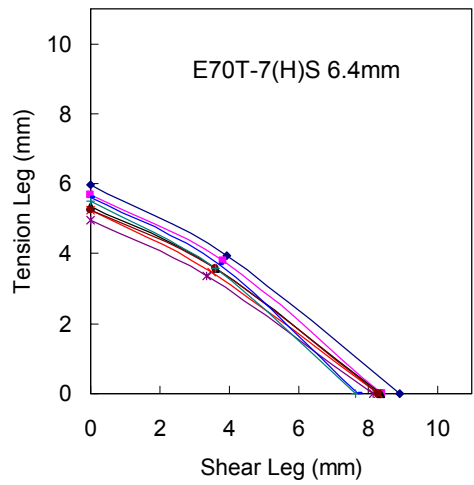
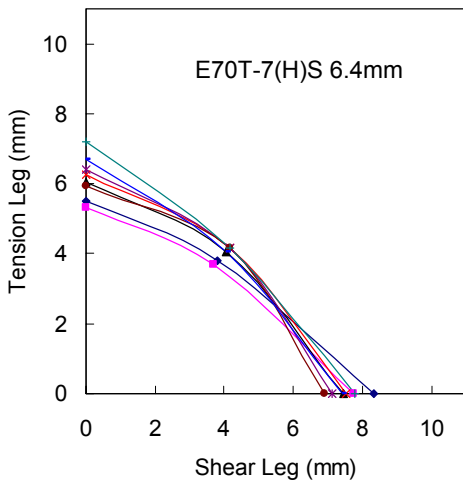

Figure C36 – Weld Profile for Specimen T12-3

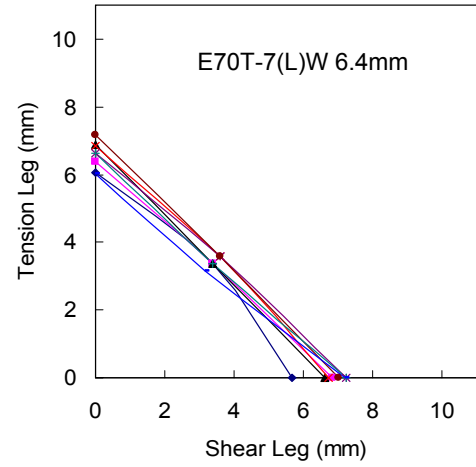
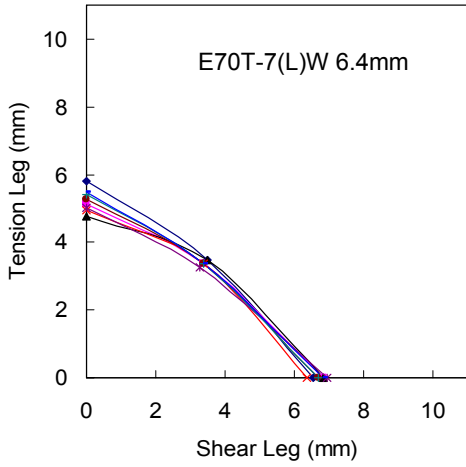

Figure C37 – Weld Profile for Specimen T13-1

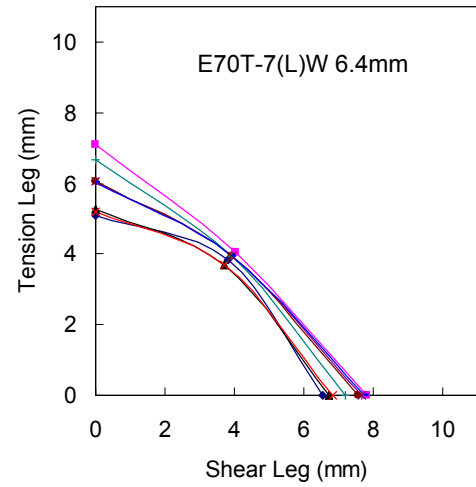
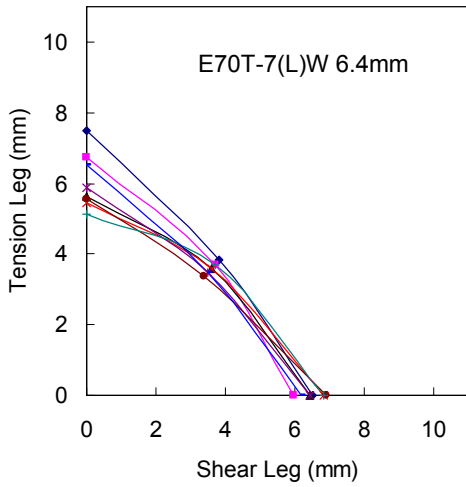

Figure C38 – Weld Profile for Specimen T13-2

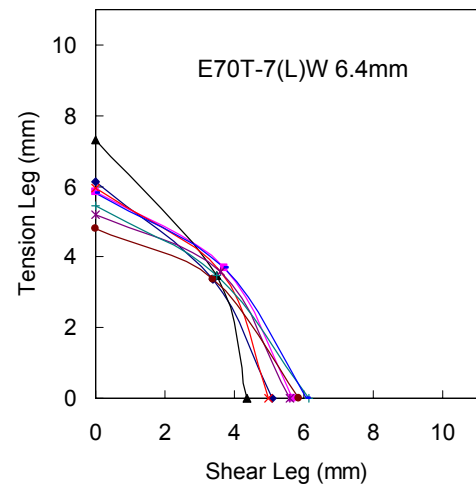
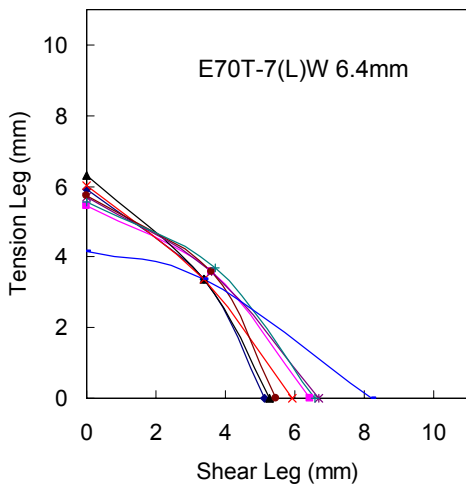

Figure C39 – Weld Profile for Specimen T13-3

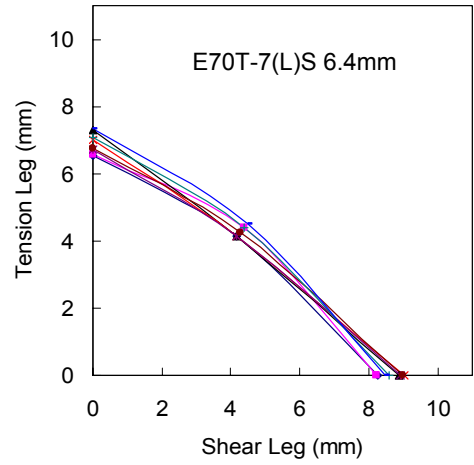
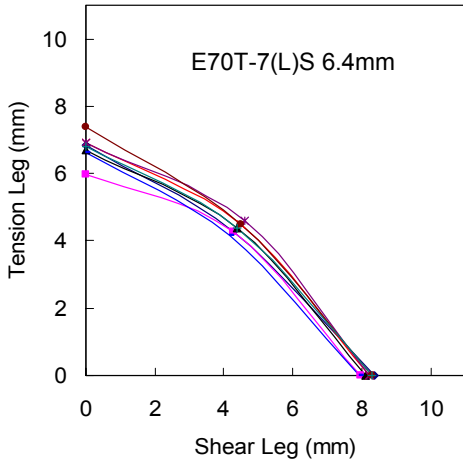

Figure C40 – Weld Profile for Specimen T14-1

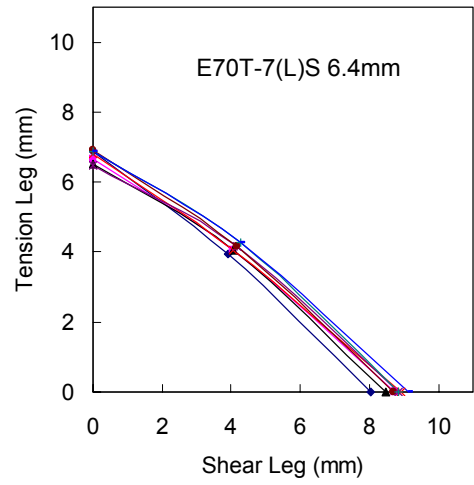
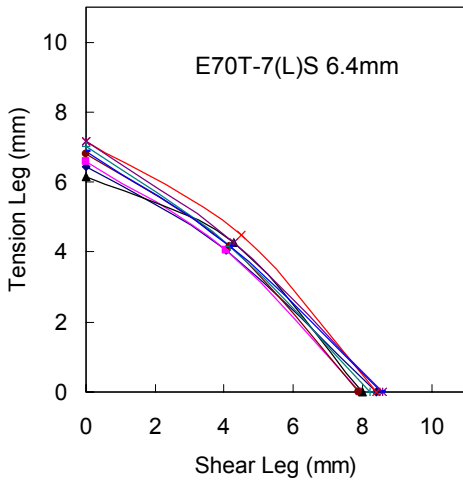

Figure C41 – Weld Profile for Specimen T14-2

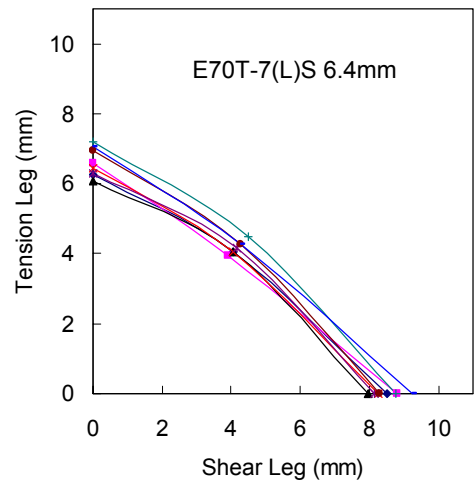
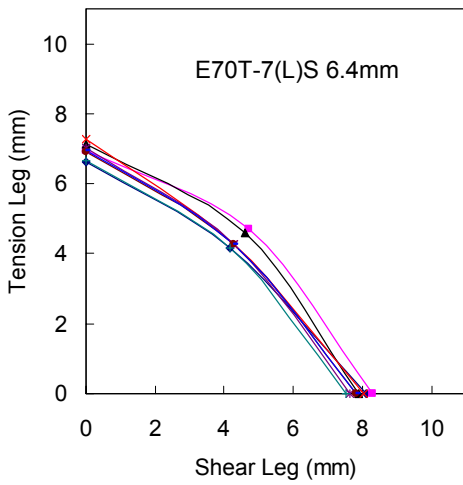

Figure C42 – Weld Profile for Specimen T14-3

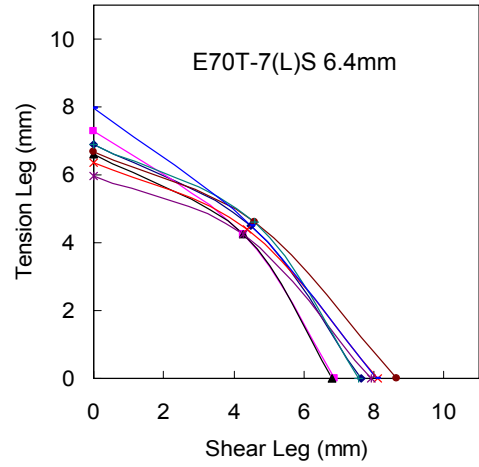
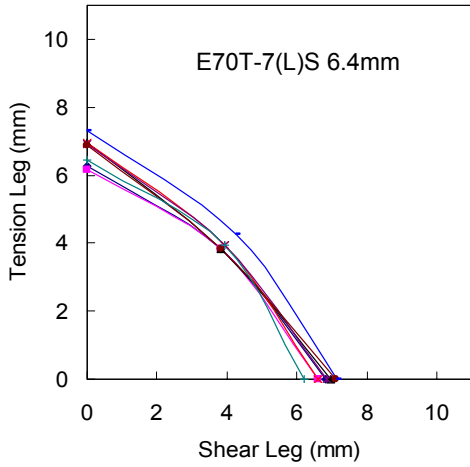

Figure C43 – Weld Profile for Specimen T15-1

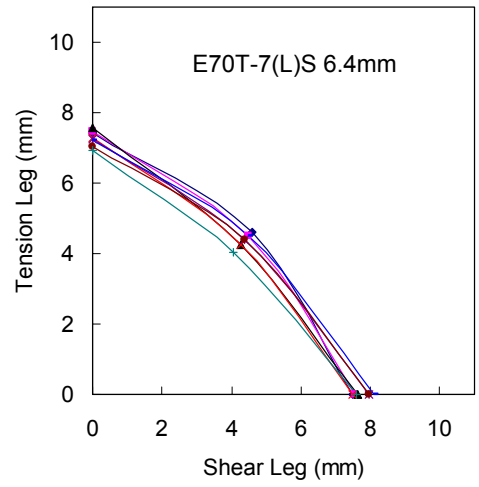
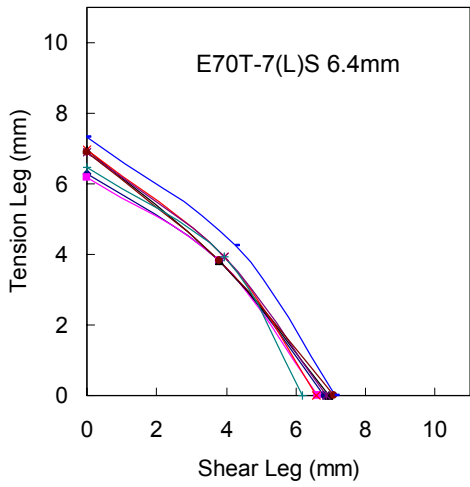

Figure C44 – Weld Profile for Specimen T15-2

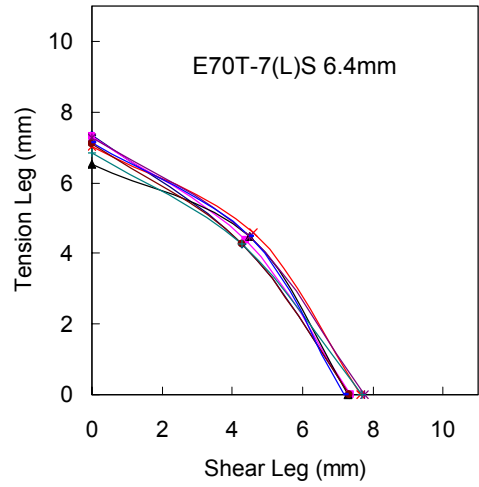
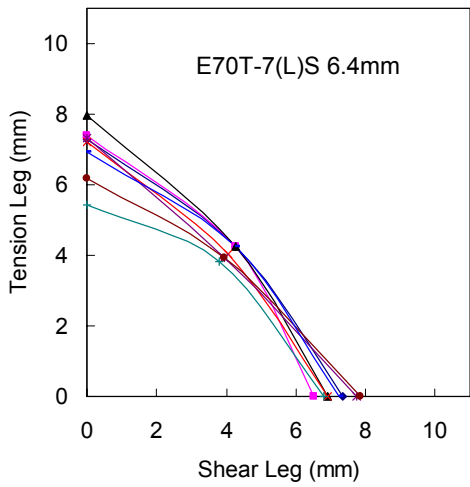

Figure C45 – Weld Profile for Specimen T15-3

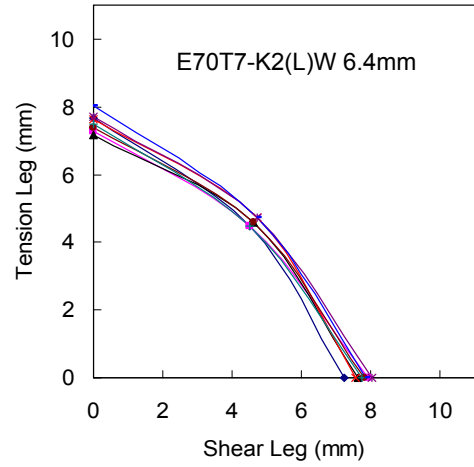
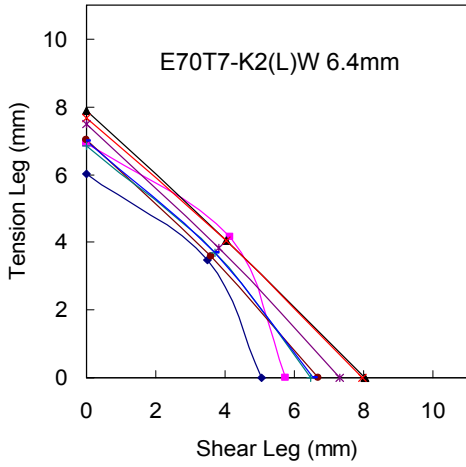

Figure C46 – Weld Profile for Specimen T16-1

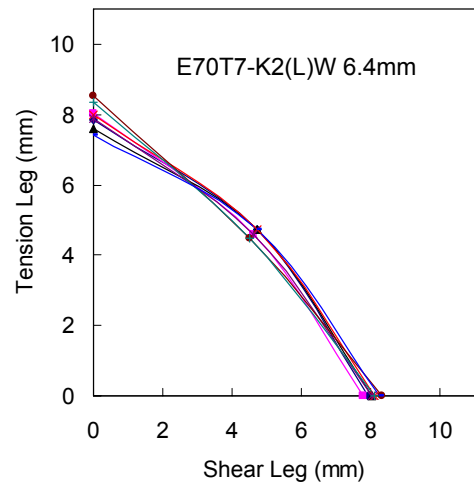
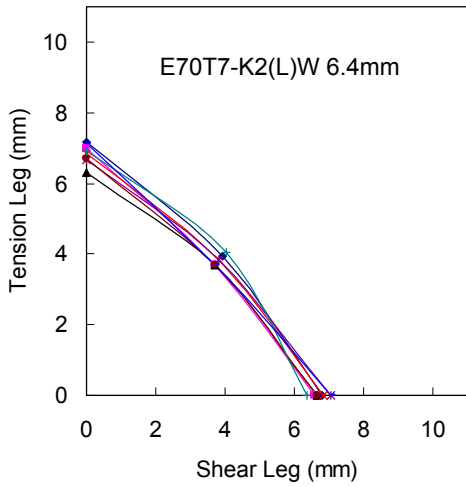

Figure C47 – Weld Profile for Specimen T16-2

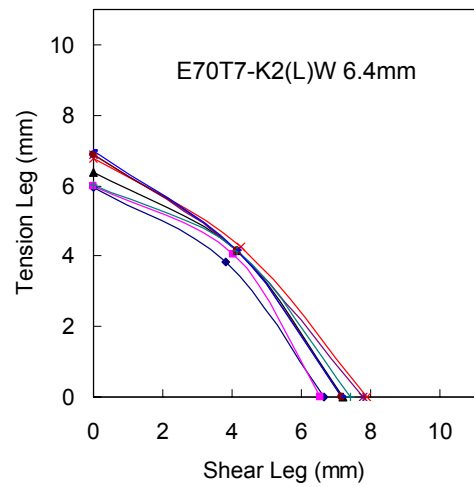
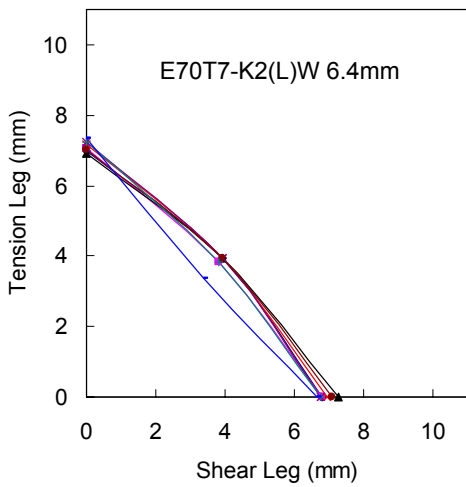

Figure C48 – Weld Profile for Specimen T16-3

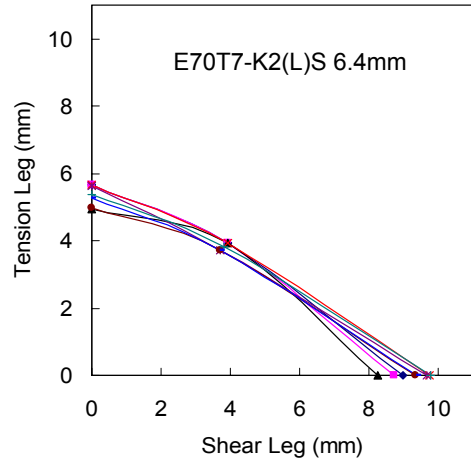
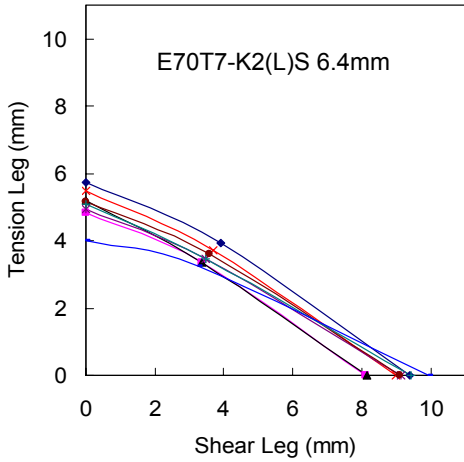

Figure C49 – Weld Profile for Specimen T17-1

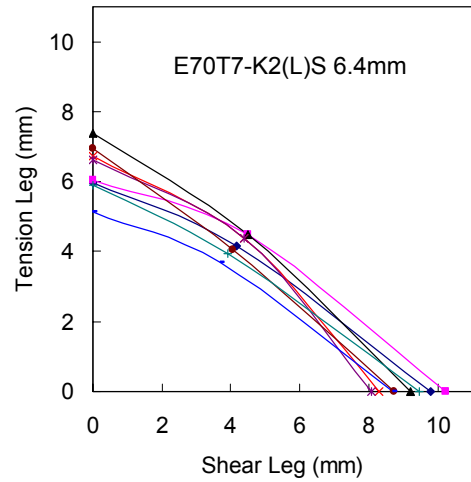
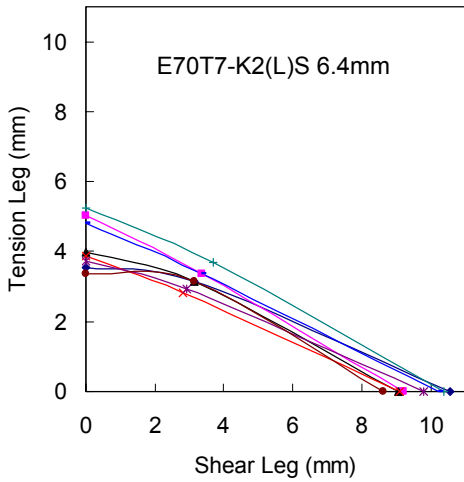

Figure C50 – Weld Profile for Specimen T17-2

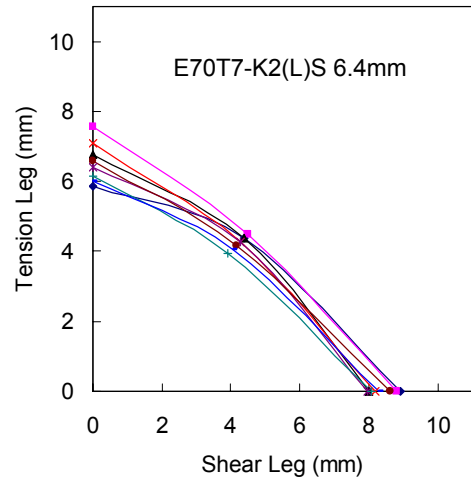
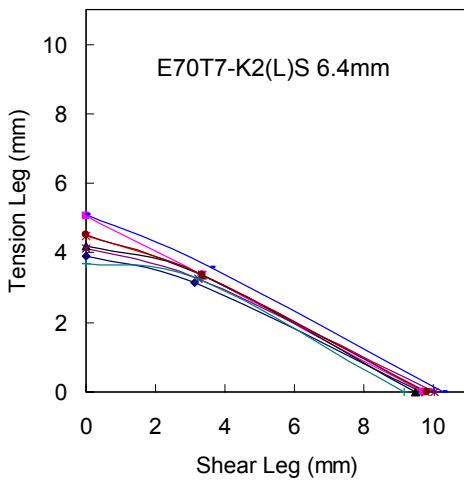

Figure C51 – Weld Profile for Specimen T17-3

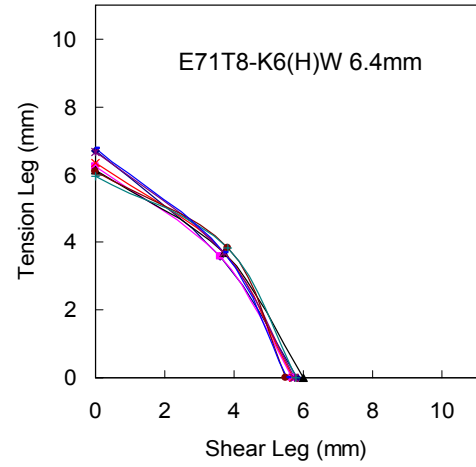
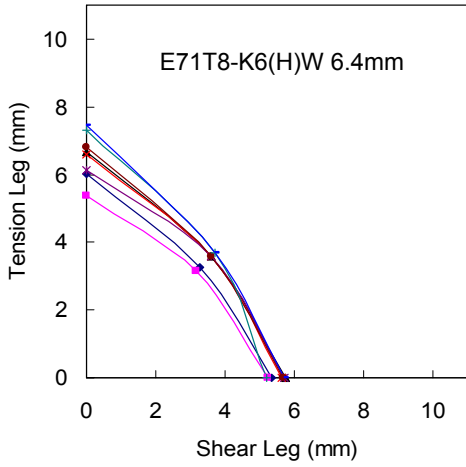

Figure C52 – Weld Profile for Specimen T18-1

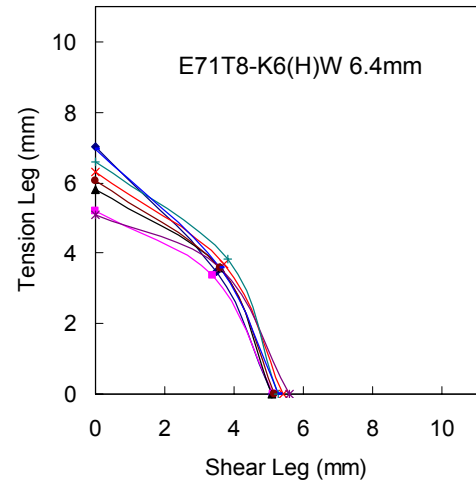
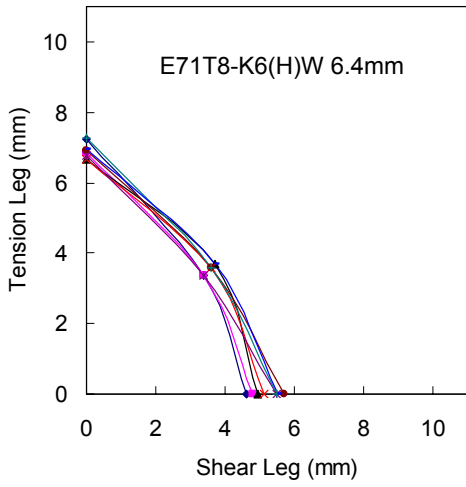

Figure C53 – Weld Profile for Specimen T18-2

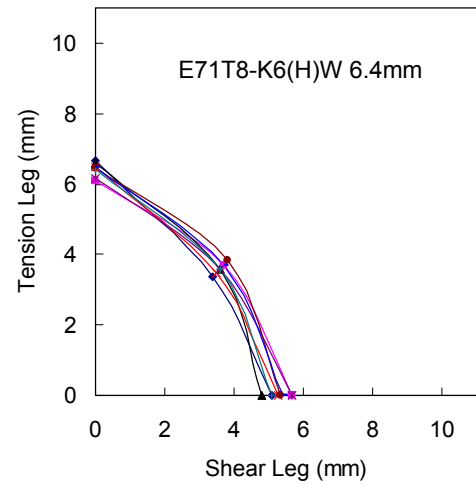
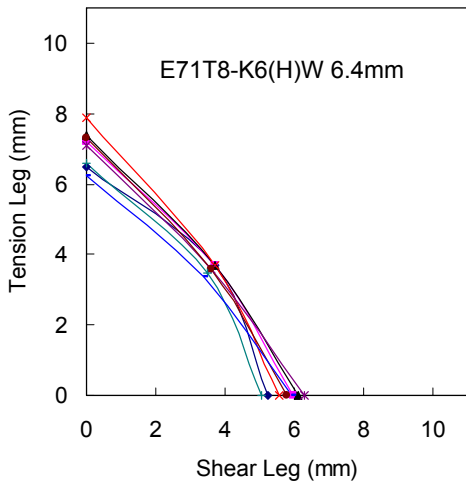

Figure C54 – Weld Profile for Specimen T18-3

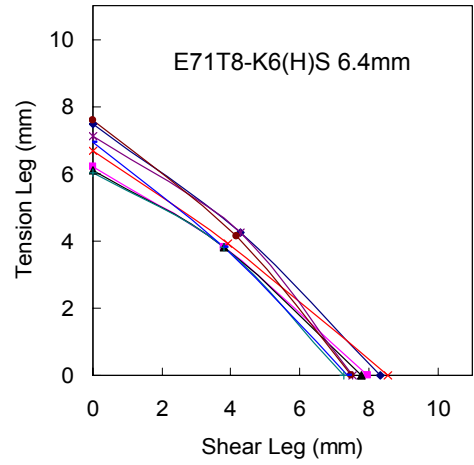
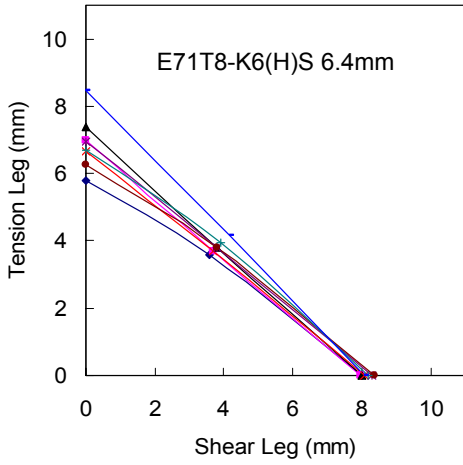

Figure C55 – Weld Profile for Specimen T19-1

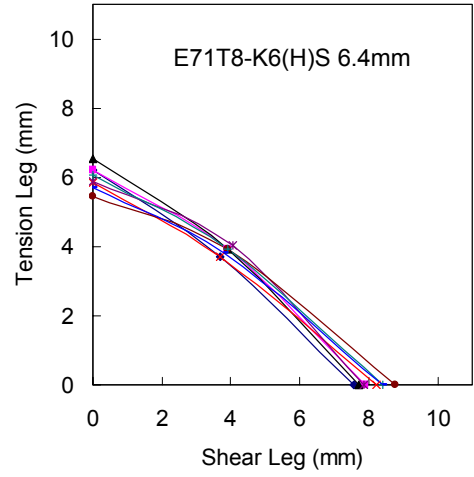
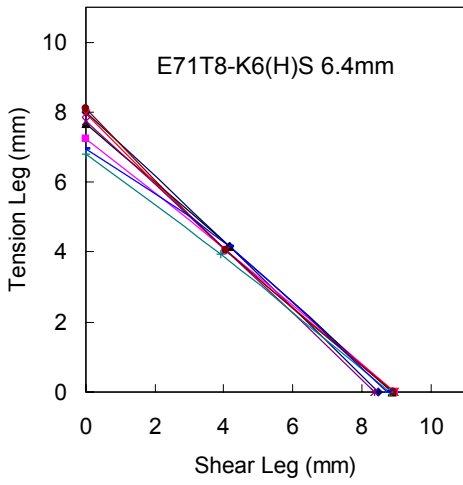

Figure C56 – Weld Profile for Specimen T19-2

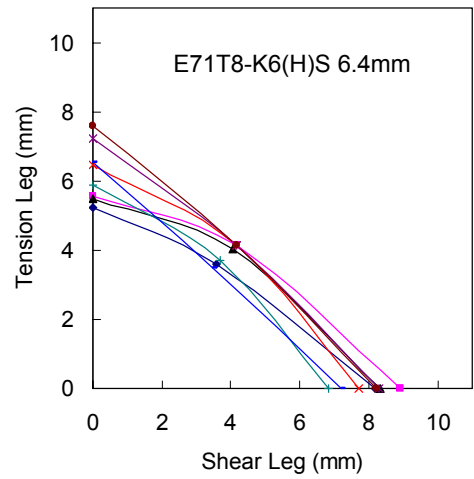
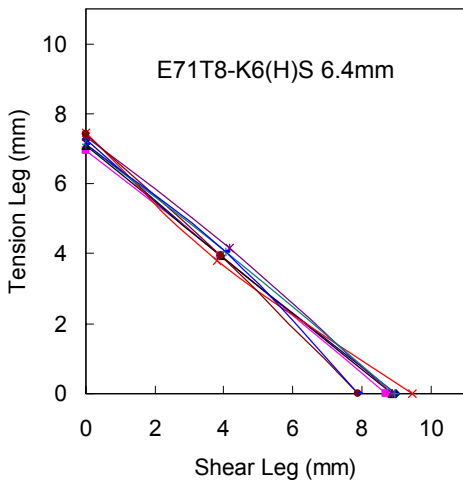

Figure C57 – Weld Profile for Specimen T19-3

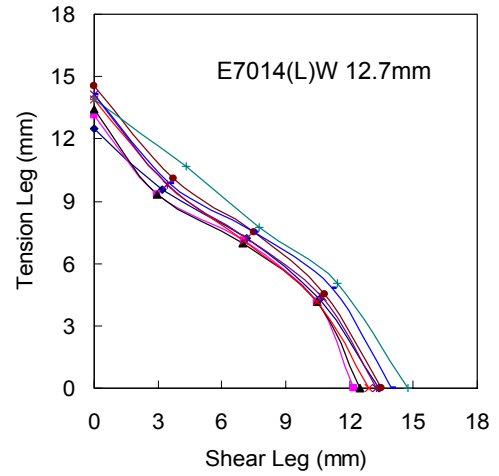
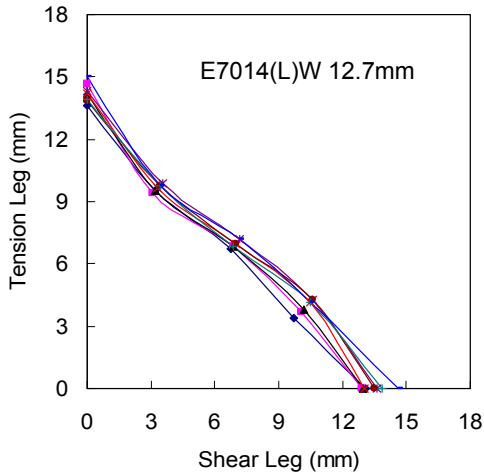

Figure C58 – Weld Profile for Specimen T20-1

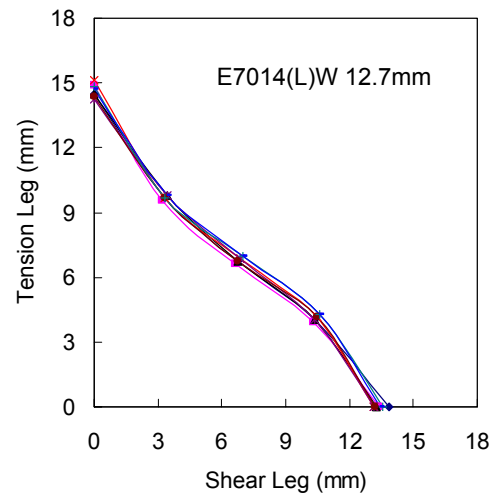
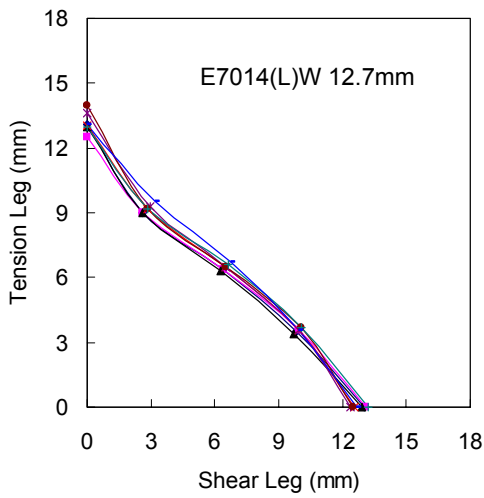

Figure C59 – Weld Profile for Specimen T20-2

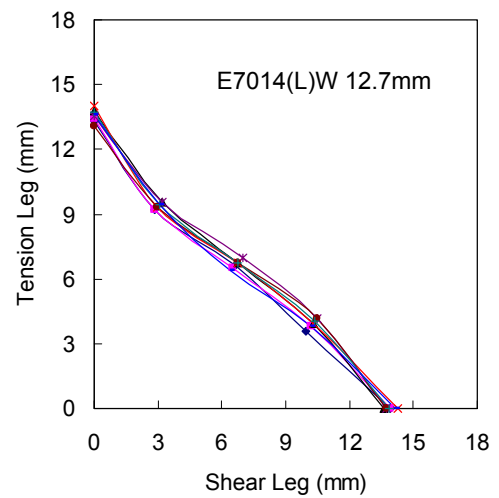
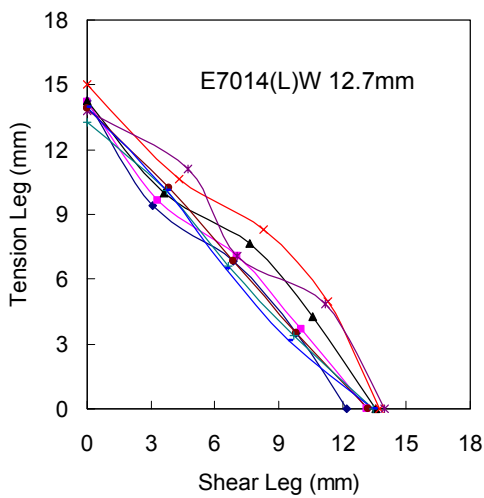

Figure C60 – Weld Profile for Specimen T20-3

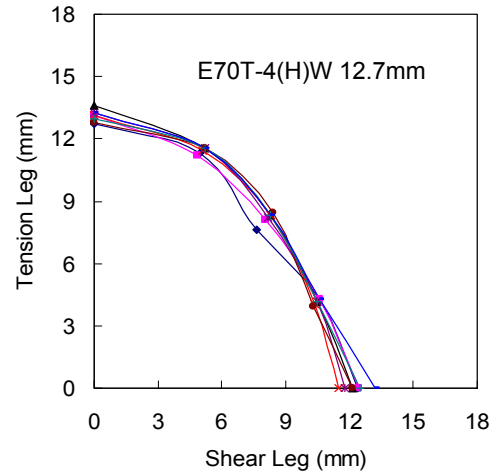
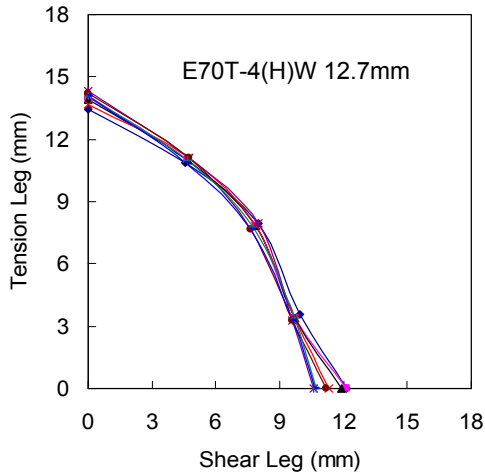

Figure C61 – Weld Profile for Specimen T21-1

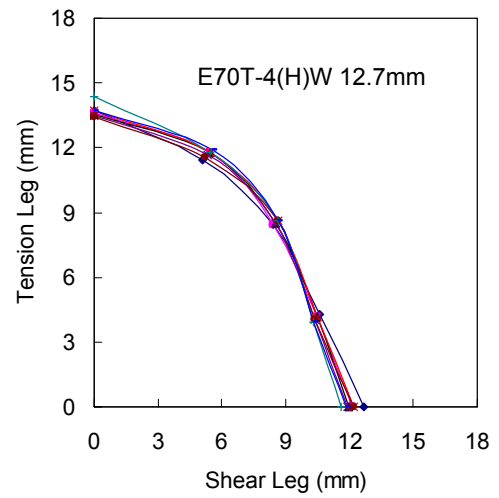
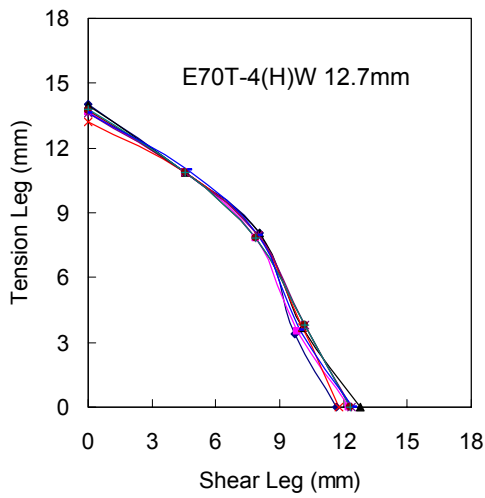

Figure C62 – Weld Profile for Specimen T21-2

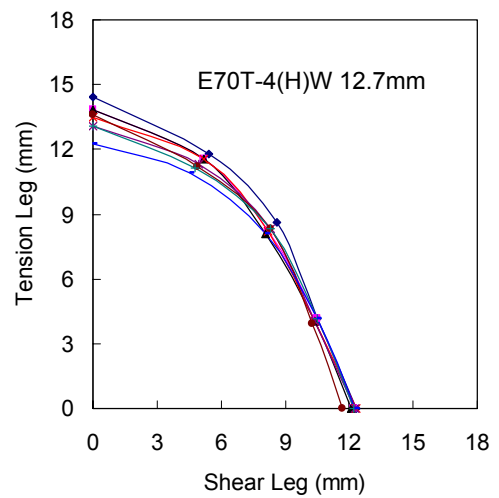
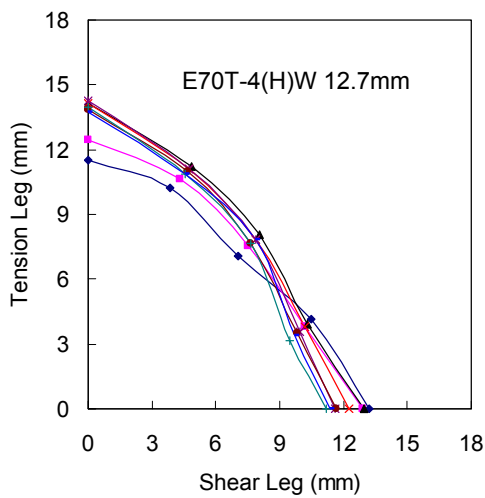

Figure C63 – Weld Profile for Specimen T21-3

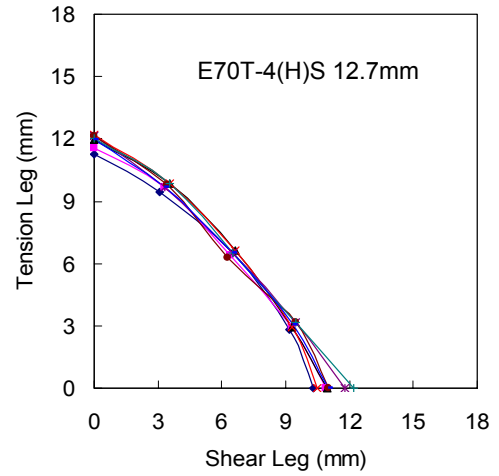
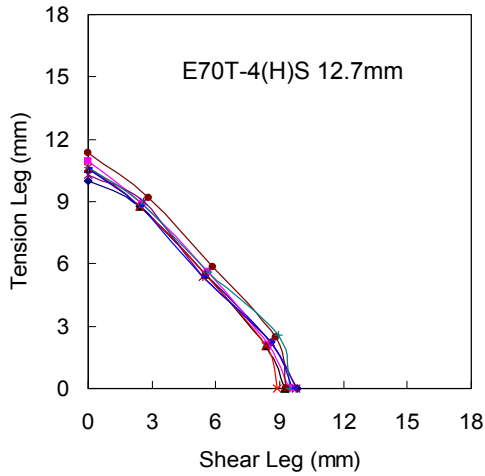

Figure C64 – Weld Profile for Specimen T22-1

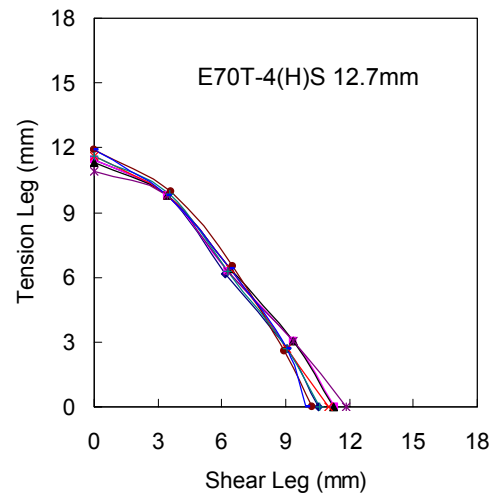
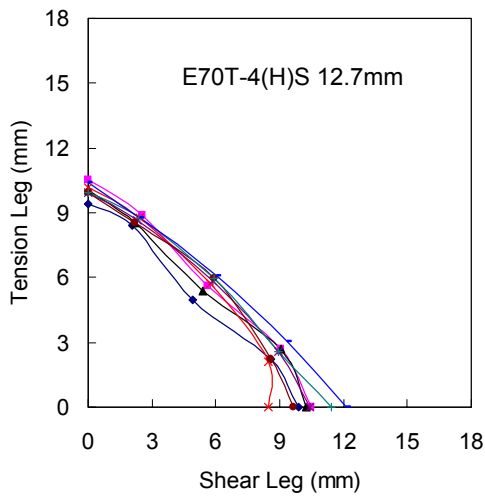

Figure C65 – Weld Profile for Specimen T22-2

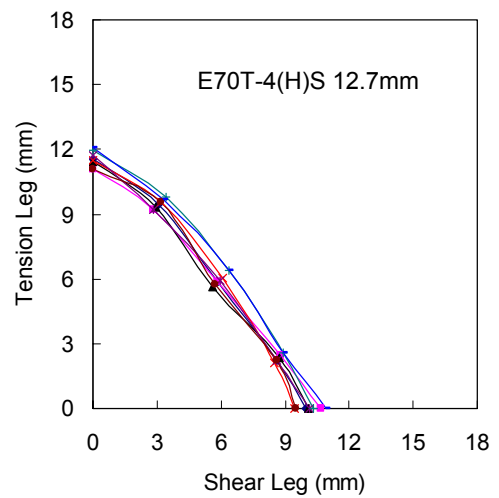
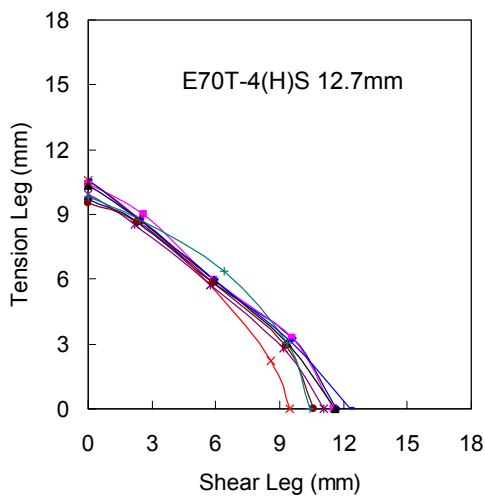

Figure C66 – Weld Profile for Specimen T22-3

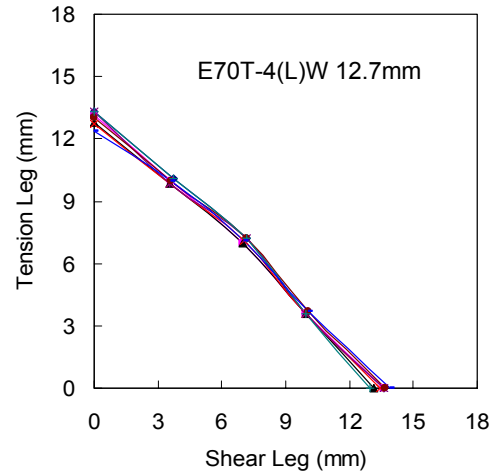
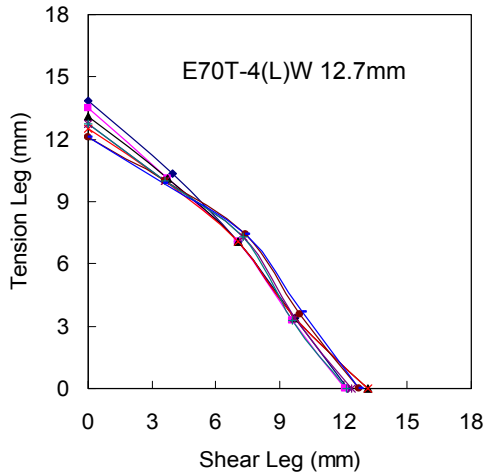

Figure C67 – Weld Profile for Specimen T23-1

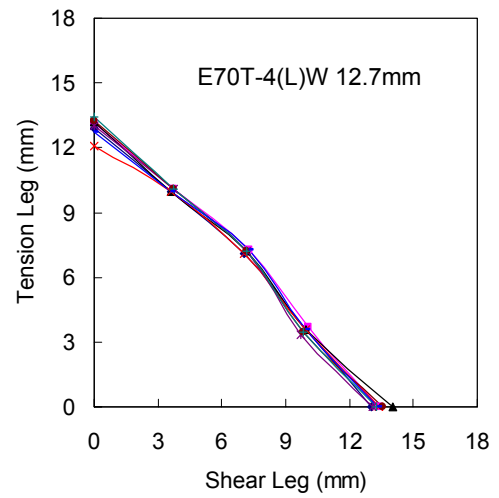
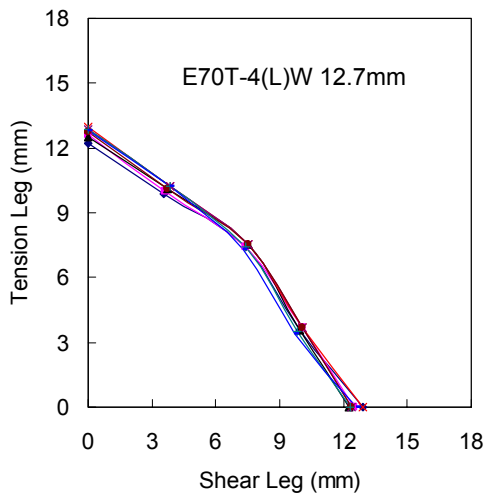

Figure C68 – Weld Profile for Specimen T23-2

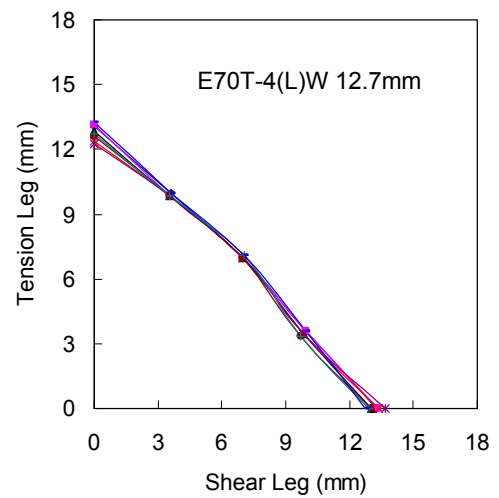
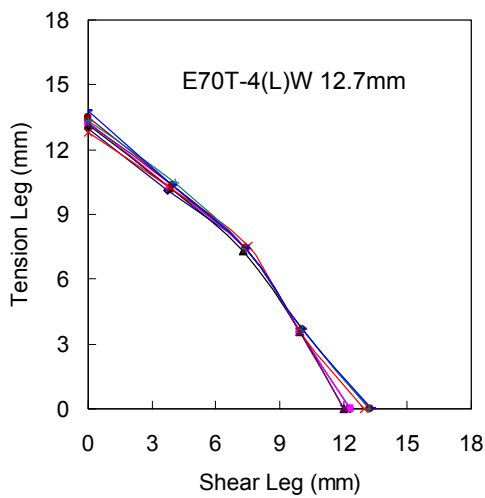

Figure C69 – Weld Profile for Specimen T23-3

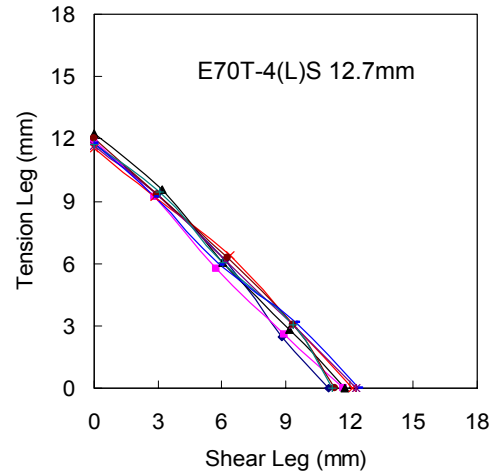
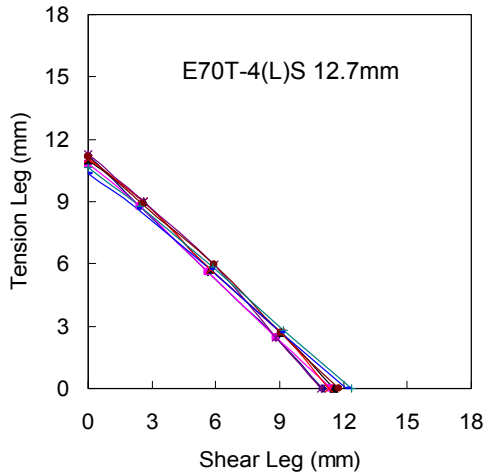

Figure C70 – Weld Profile for Specimen T24-1

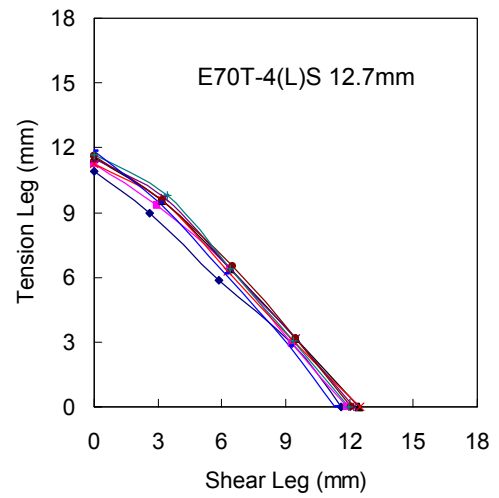
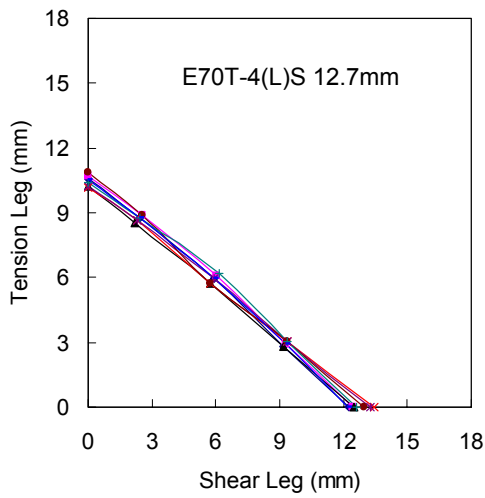

Figure C71 – Weld Profile for Specimen T24-2

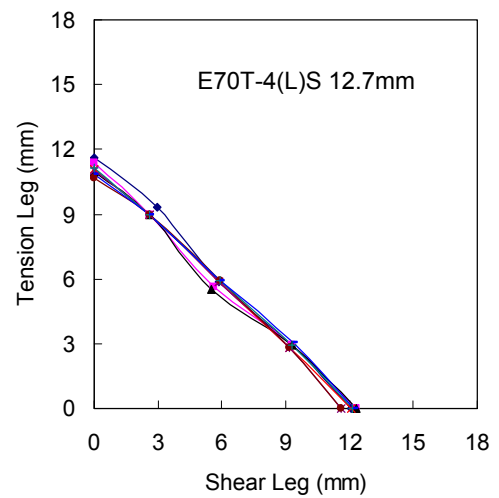
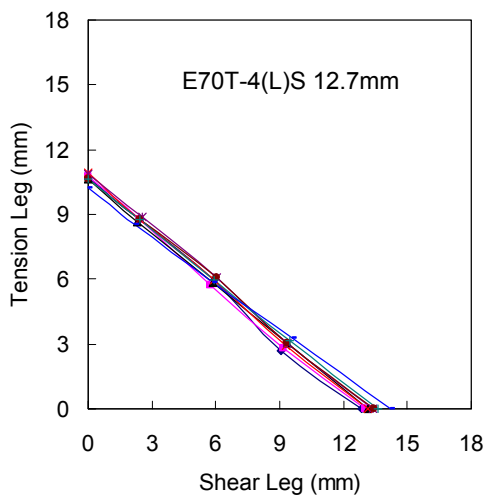

Figure C72 – Weld Profile for Specimen T24-3

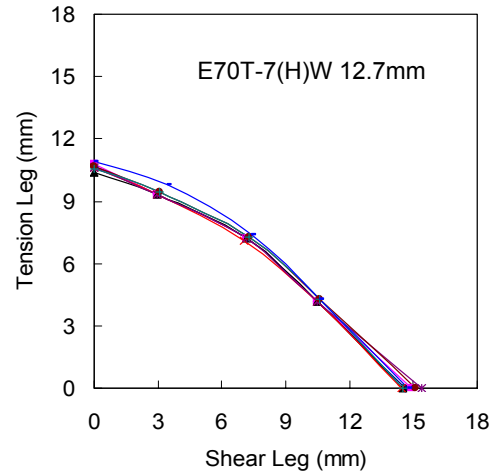
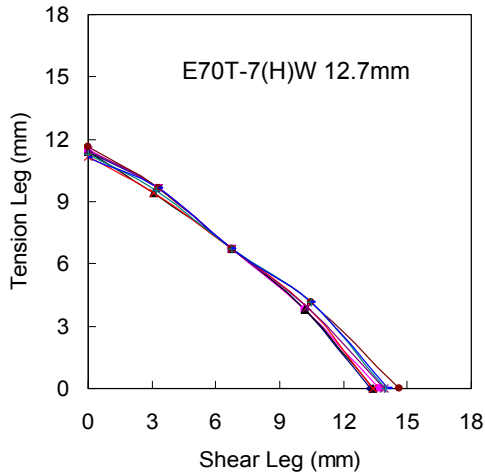

Figure C73 – Weld Profile for Specimen T25-1

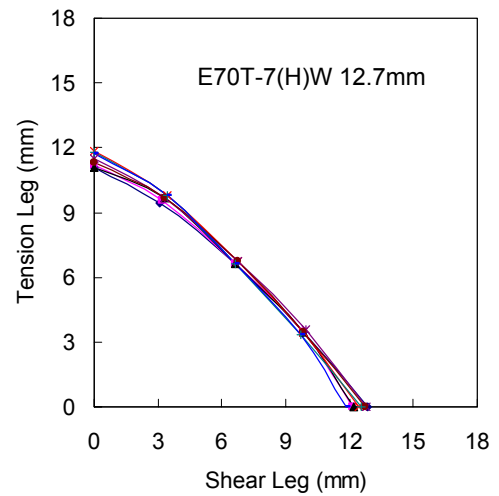
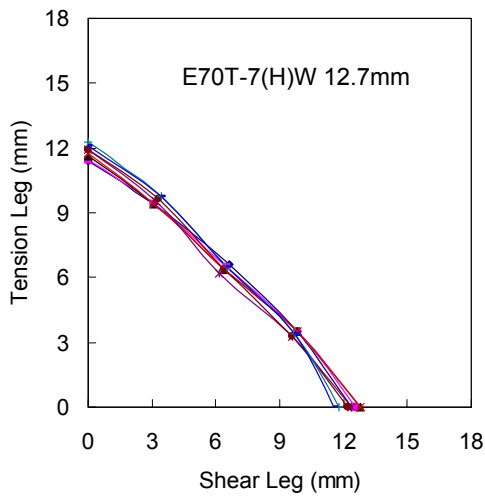

Figure C74 – Weld Profile for Specimen T25-2

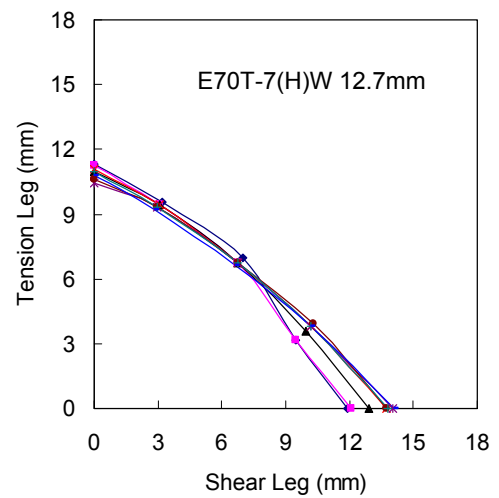
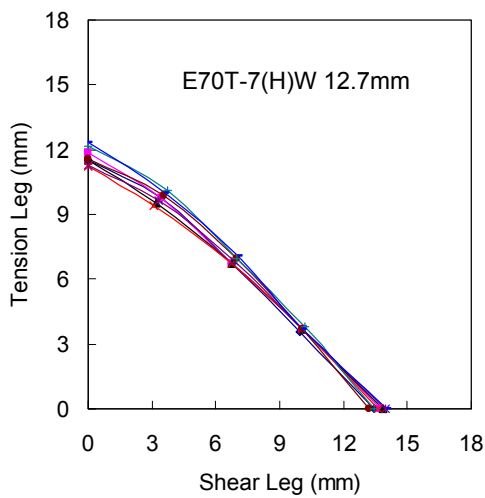

Figure C75 – Weld Profile for Specimen T25-3

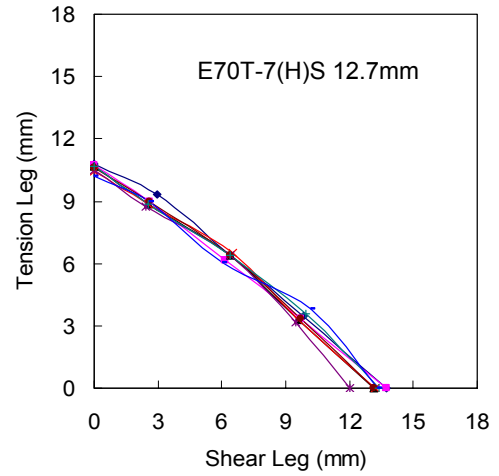
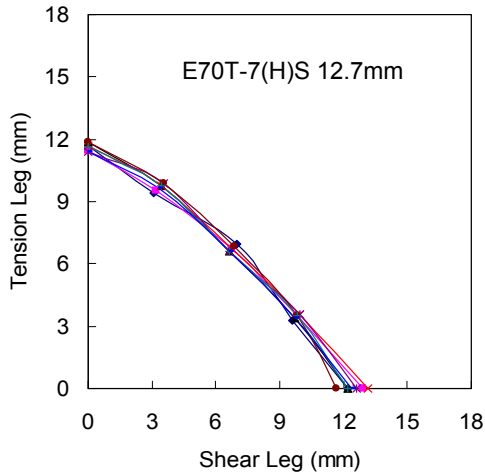

Figure C76 – Weld Profile for Specimen T26-1

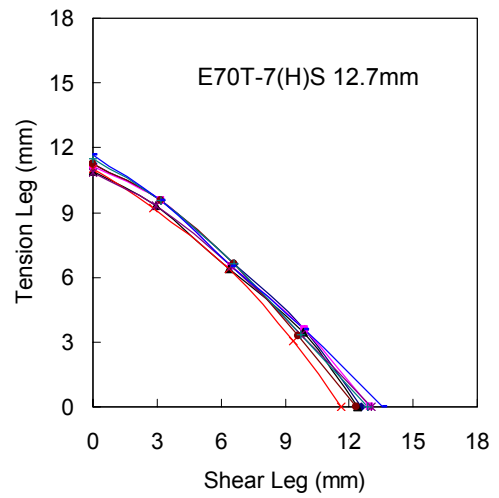
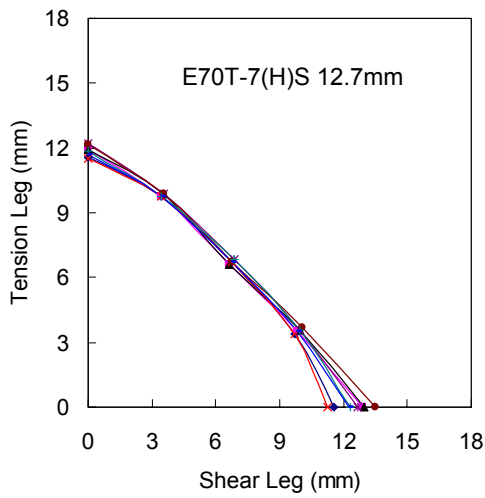

Figure C77 – Weld Profile for Specimen T26-2

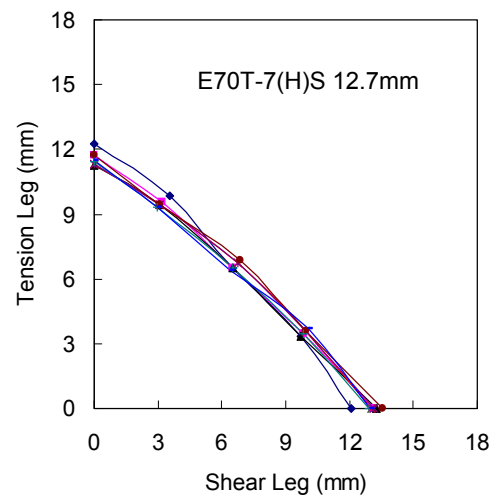
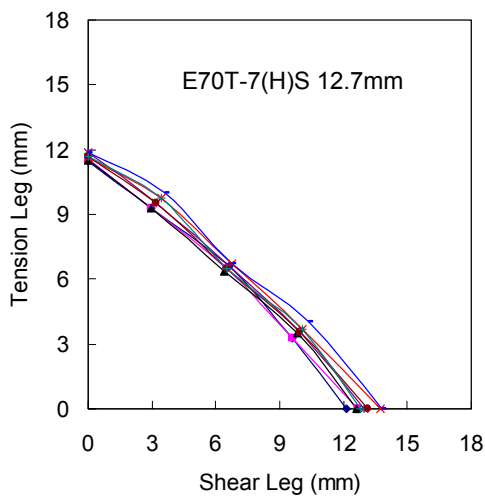

Figure C78 – Weld Profile for Specimen T26-3

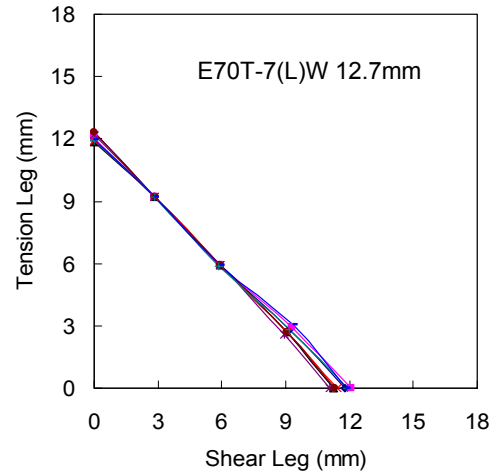
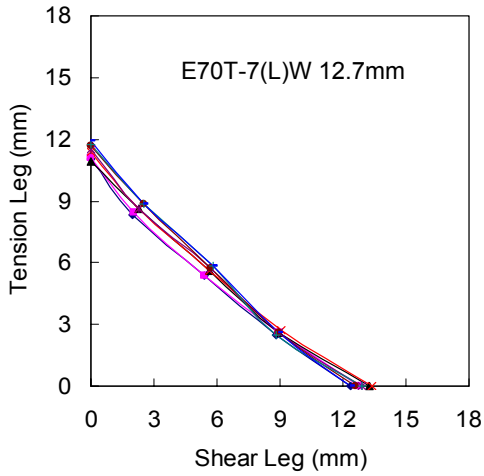

Figure C79 – Weld Profile for Specimen T27-1

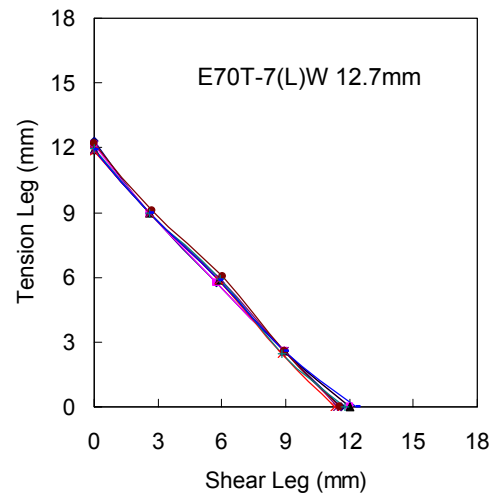
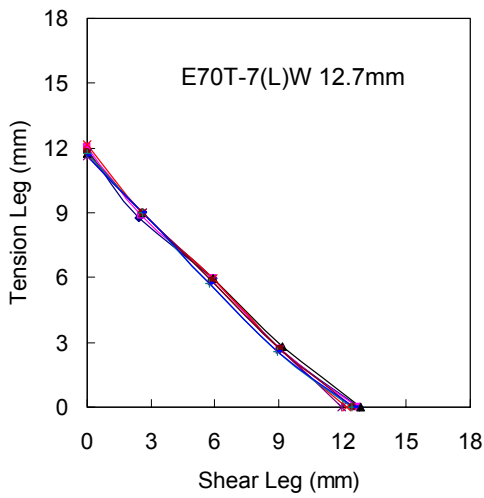

Figure C80 – Weld Profile for Specimen T27-2

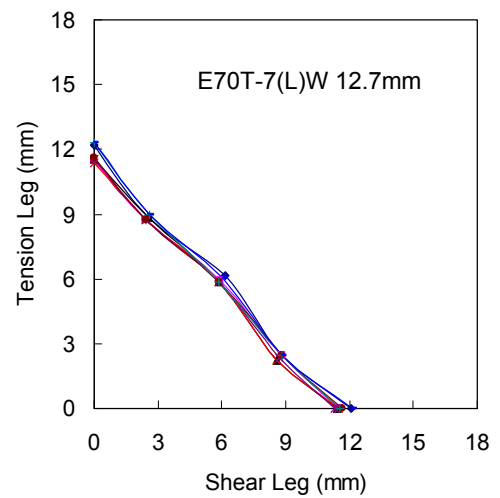
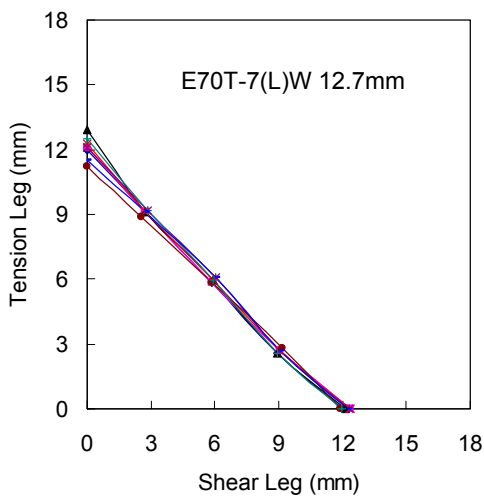

Figure C81 – Weld Profile for Specimen T27-3

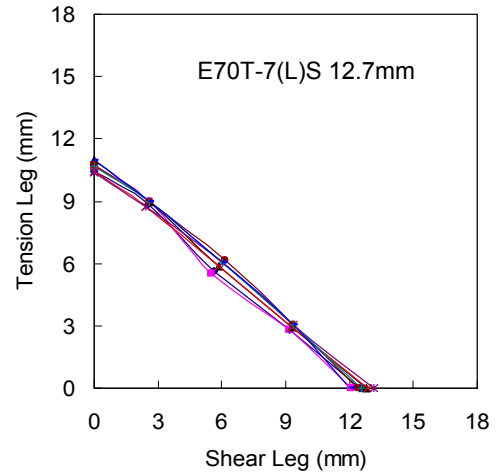
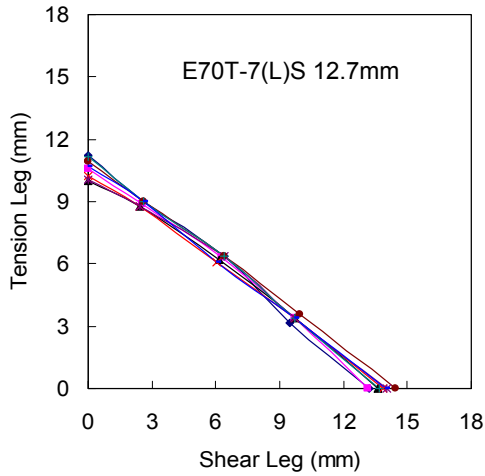

Figure C82 – Weld Profile for Specimen T28-1

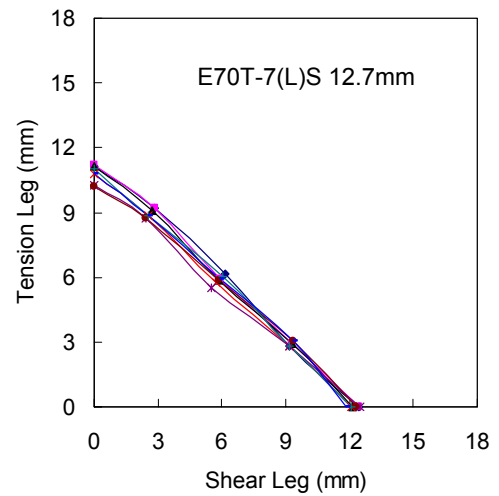
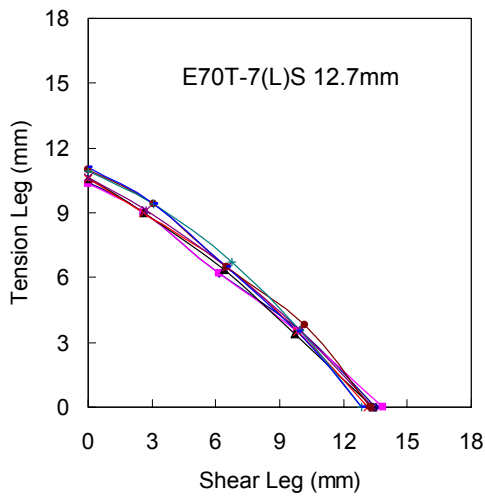

Figure C83 – Weld Profile for Specimen T28-2

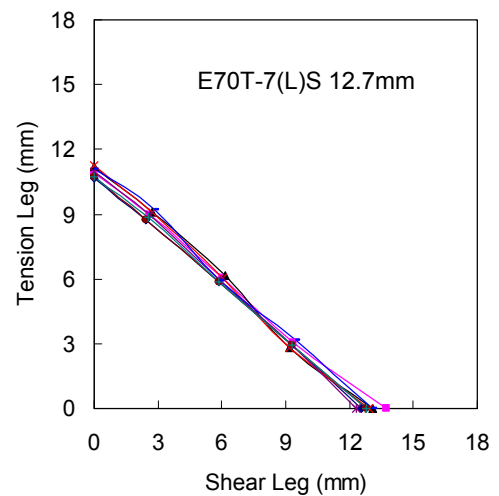
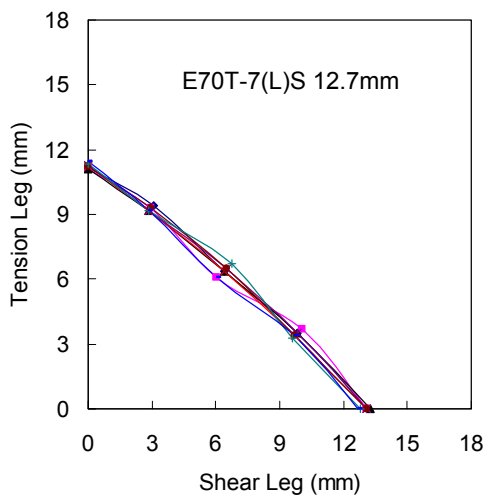

Figure C84 – Weld Profile for Specimen T28-3

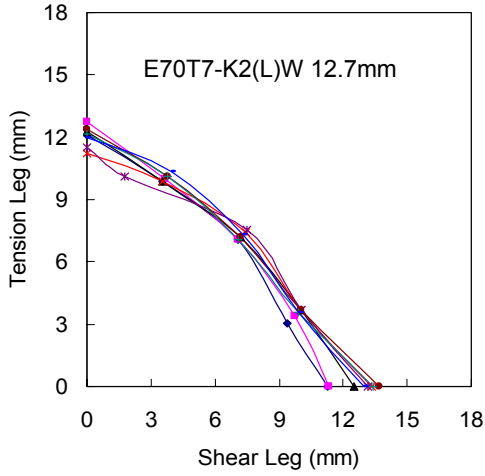

Figure C85 – Weld Profile for Specimen T29-1

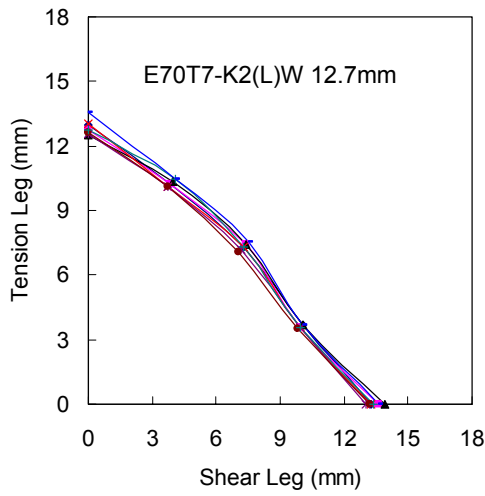
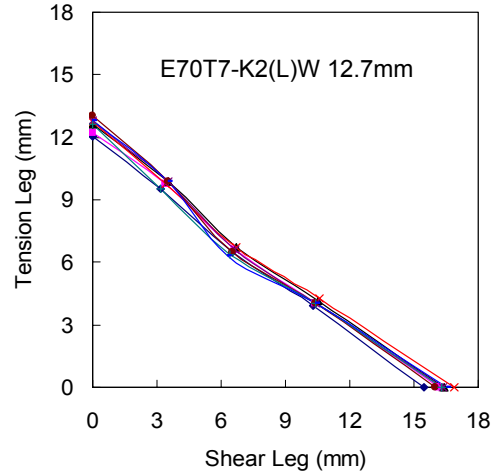

Figure C86 – Weld Profile for Specimen T29-2

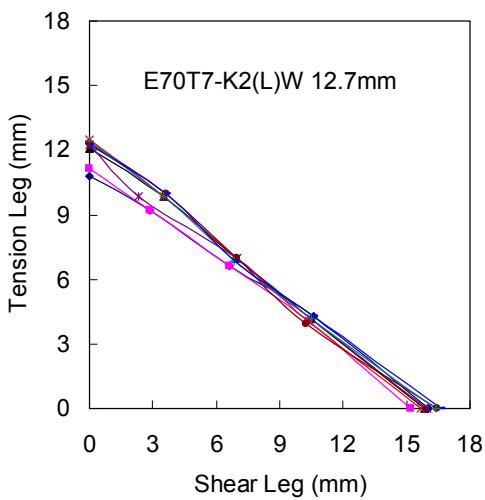
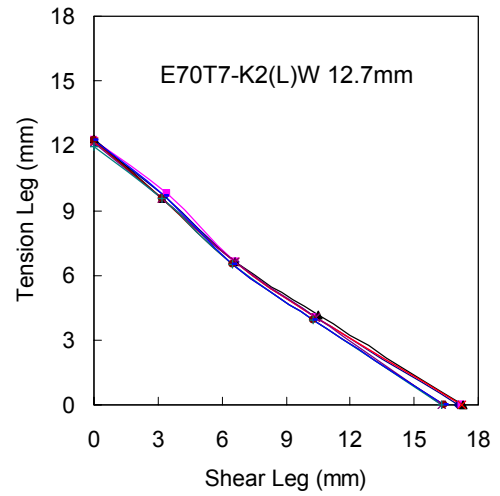
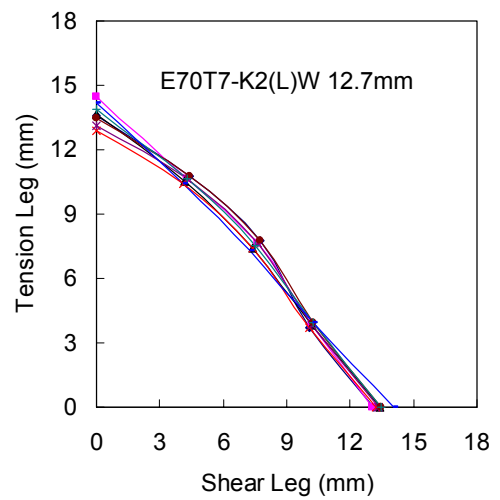

Figure C87 – Weld Profile for Specimen T29-3



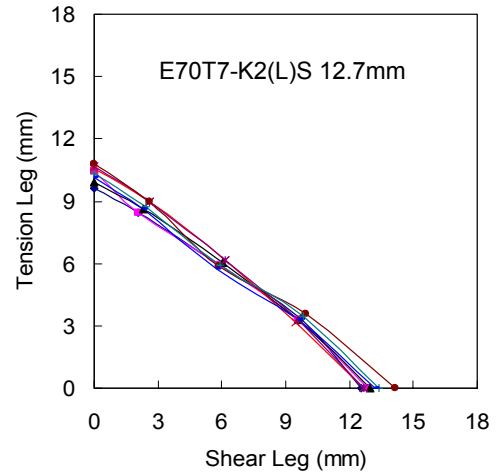
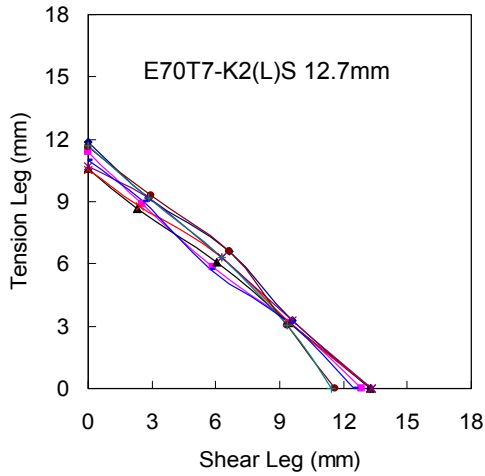

Figure C88 – Weld Profile for Specimen T30-1

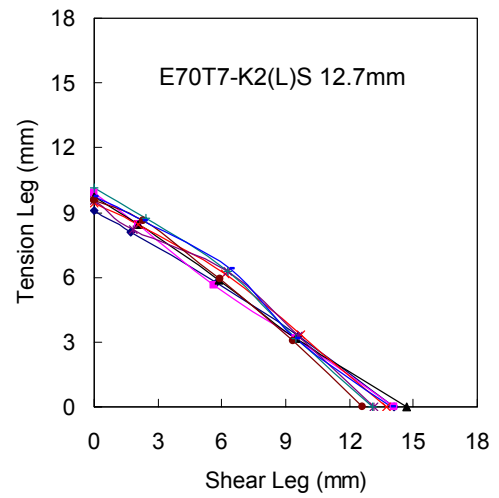
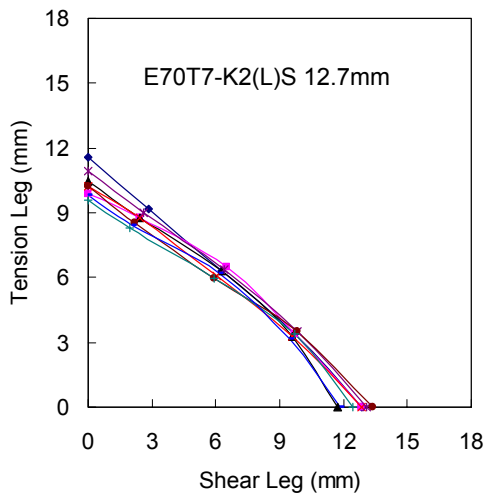

Figure C89 – Weld Profile for Specimen T30-2

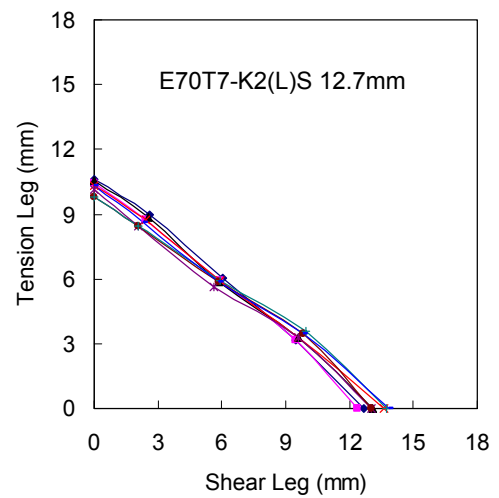
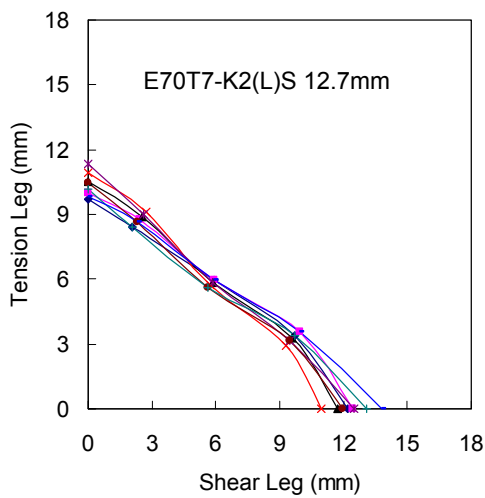

Figure C90 – Weld Profile for Specimen T30-3

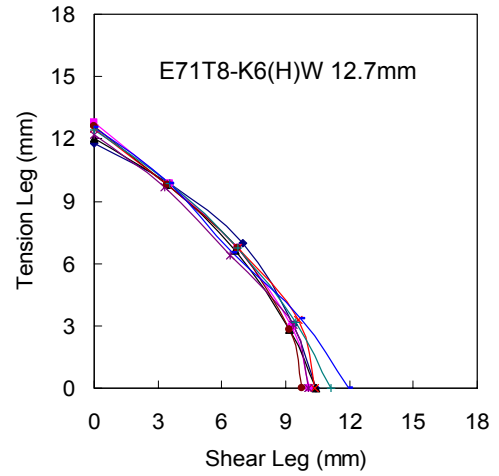
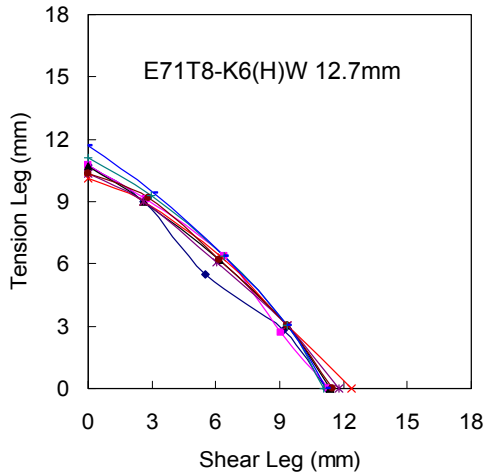

Figure C91 – Weld Profile for Specimen T31-1

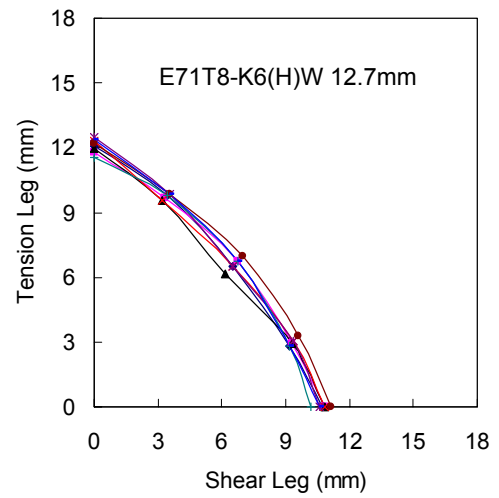
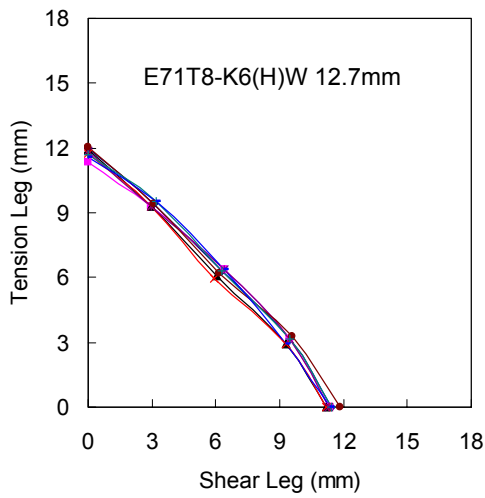

Figure C92 – Weld Profile for Specimen T31-2

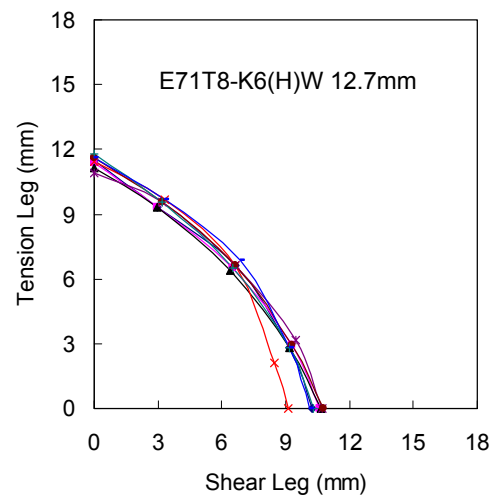
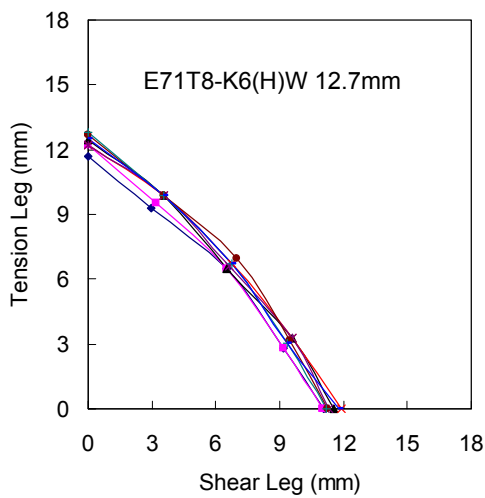

Figure C93 – Weld Profile for Specimen T31-3

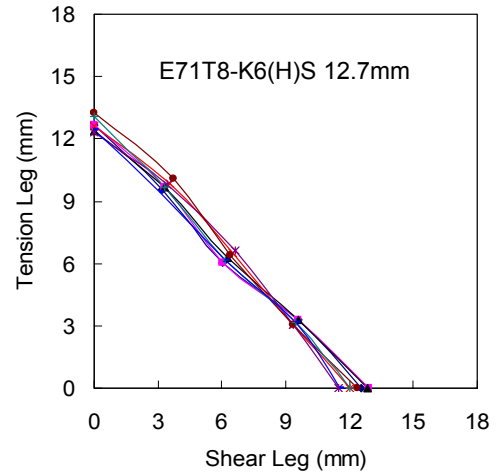
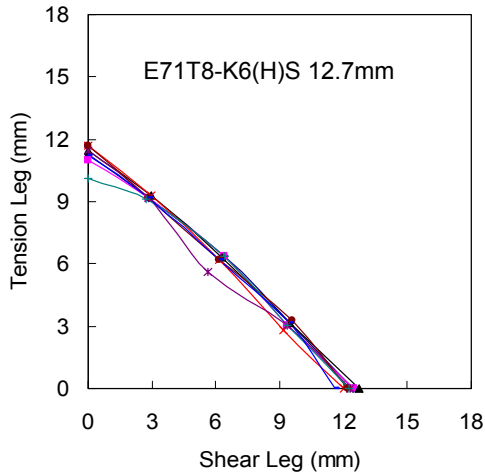

Figure C94 – Weld Profile for Specimen T32-1

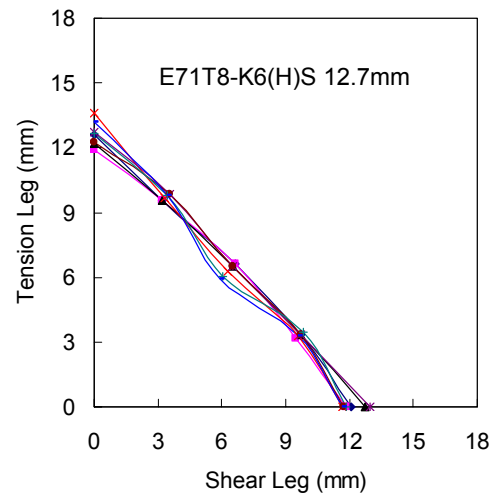
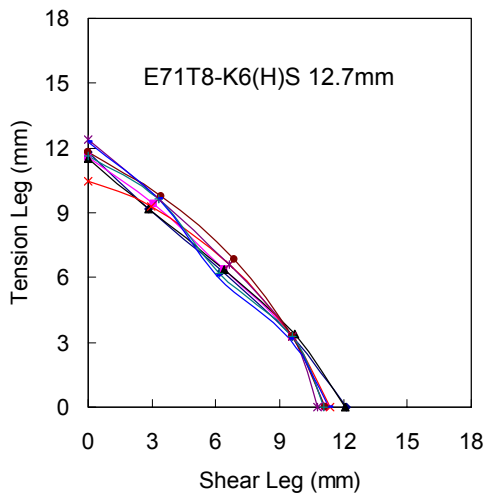

Figure C95 – Weld Profile for Specimen T32-2

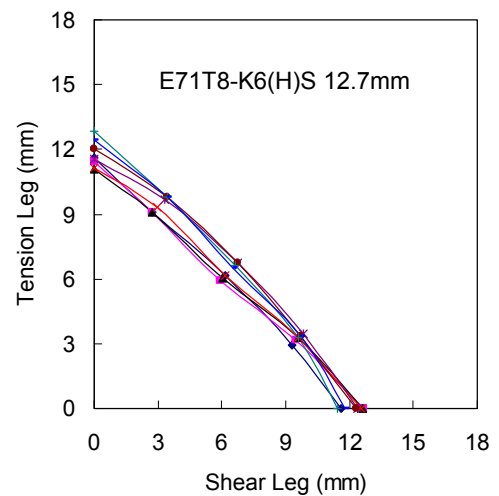
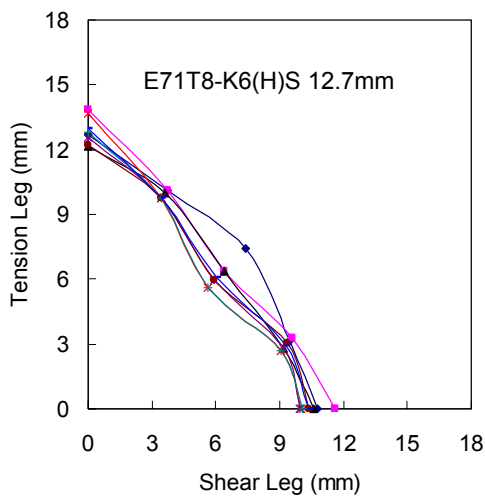

Figure C96 – Weld Profile for Specimen T32-3

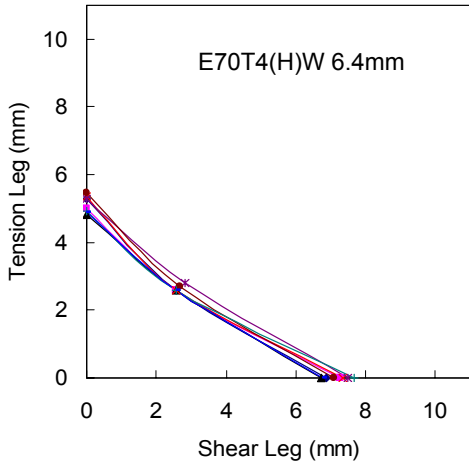

Figure C97 – Weld Profile for Specimen C1-1

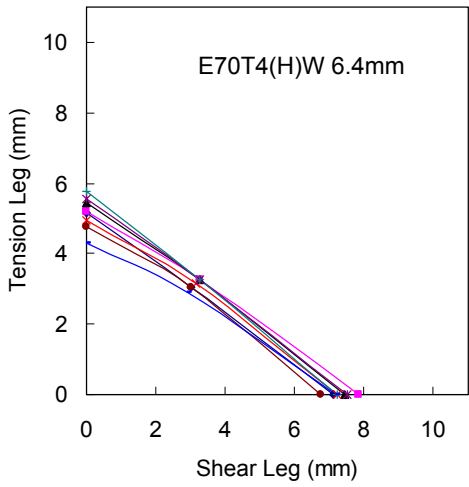
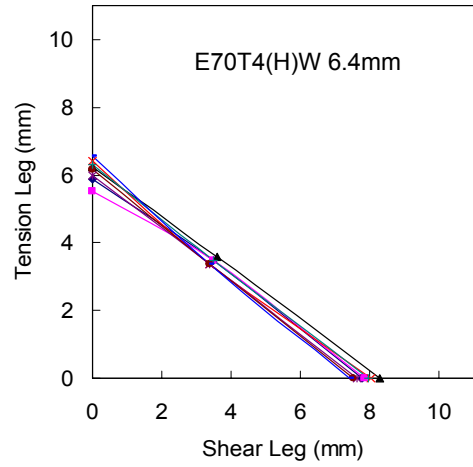

Figure C98 – Weld Profile for Specimen C1-2

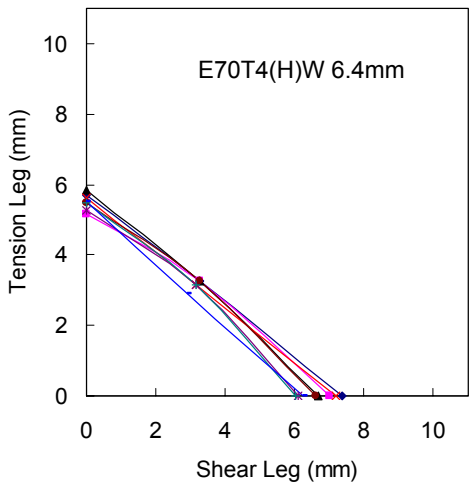
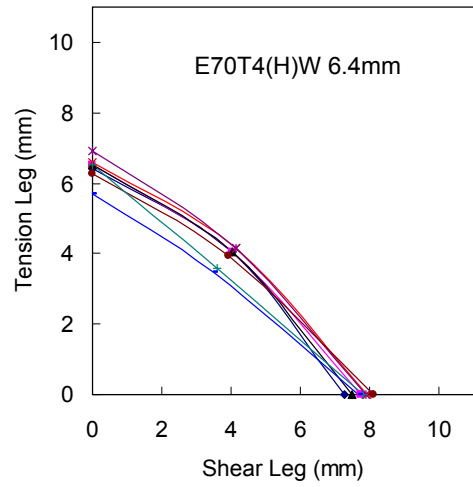
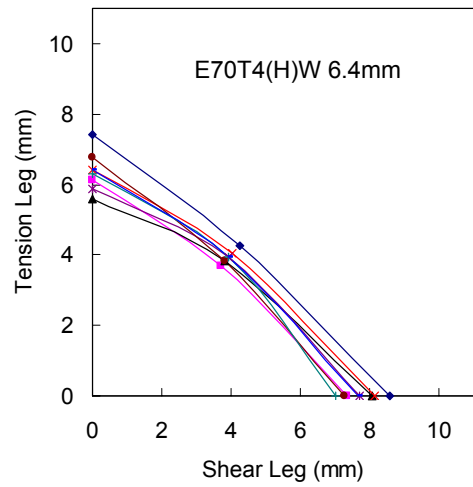

Figure C99 – Weld Profile for Specimen C1-3



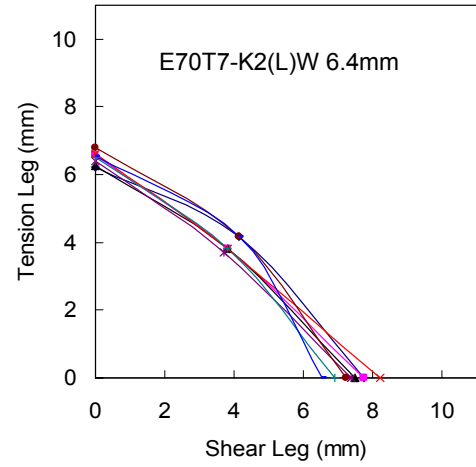
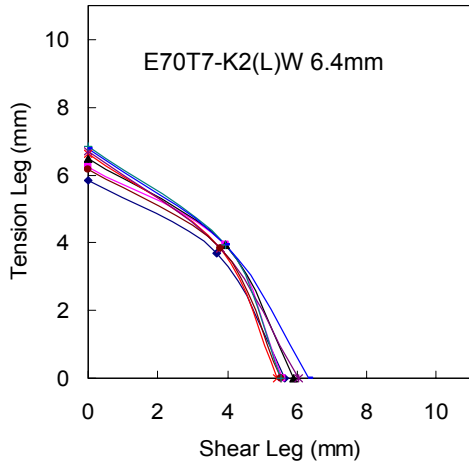

Figure C100 – Weld Profile for Specimen C2-1

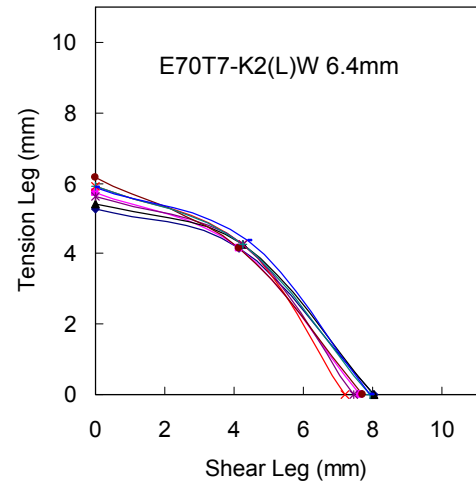
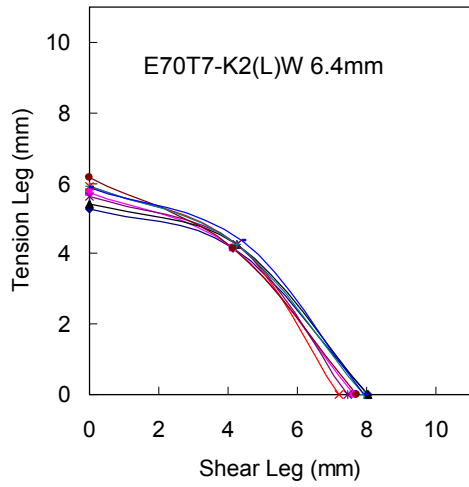

Figure C101 – Weld Profile for Specimen C2-2

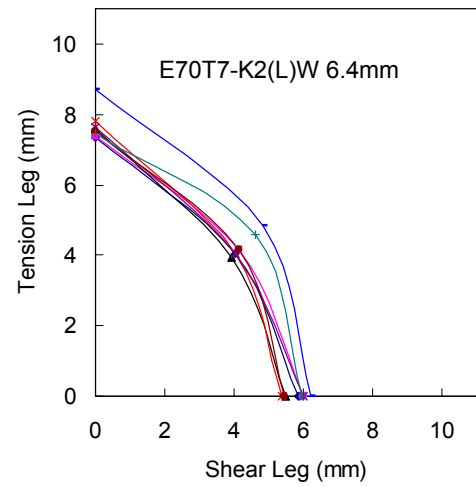
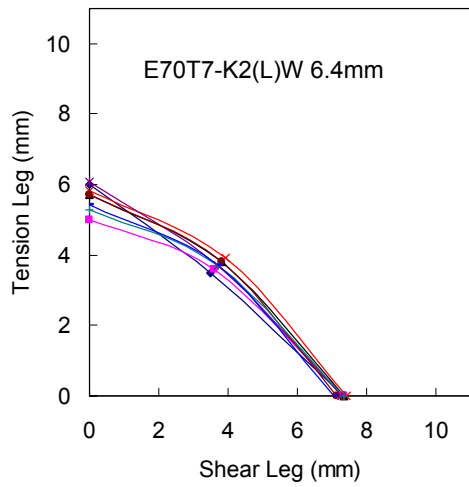

Figure C102 – Weld Profile for Specimen C2-3

APPENDIX D

Material Tension Coupon Test Results

TABLE D1 – PLATE TENSION COUPON TEST RESULTS

Nominal Thickness	Coupon Number	Static Yield Strength (MPa)	Static Tensile Strength (MPa)	Modulus of Elasticity (MPa)	Elongation ⁽²⁾ (%)	Reduction of Area (%)
9.5 mm	1	416	550	215 900	29.5	52.5
	2	419	551	199 000	31.4	51.9
	Mean	418	551	207 500	30.5	52.2
15.9 mm	1	347	466	202 700	38.2	66.6
	2	347	465	200 100	38.2	67.2
	Mean	347	466	201 400	38.2	66.9
19.1 mm	1	392	528	194 700	40.6	64.2
	2	392	526	196 100	40.4	65.1
	Mean	392	527	195 400	40.5	64.6
25.4 mm	1	388	538	201 800	40.9	62.8
	2	385	538	201 300	40.9	64.1
	Mean	386	538	201 600	40.9	63.4

TABLE D2 – WELD METAL TENSION COUPON TEST RESULTS

Assembly Designation	Identifier	Coupon Number	Static Yield Strength (MPa)	Static Tensile Strength (MPa)	Modulus of Elasticity (MPa)	Elongation ⁽²⁾ (%)	Reduction of Area (%)
A1	E7014(L)W	1	448	517	200 400	20.6	51.7
		2	456	523	221 000	22.8	54.5
		Mean	452	520	210 700	21.7	53.1
A2	E70T-4(H)W	1	315	513	173 500	25.2	35.0
		2	312	513	214 500	25.0	45.3
		3	376	557	181 200	22.5	34.1
		4	383	— ⁽³⁾	175 000	9.4 ⁽³⁾	9.0
		5	383	557	183 200	19.9	40.4
Mean	354	535	185 500	23.2	32.7		
A3	E70T-4(H)S	1	470	630	206 100	21.1	36.5
		2	473	631	191 100	23.4	51.0
		Mean	472	631	198 600	22.3	43.8
A4	E70T-4(L)W	1	407	562	200 900	26.1	54.9
		2	407	563	205 900	29.5	55.2
		Mean	407	562	203 400	27.8	55.0
A5	E70T-7(H)W	1	465	609	201 300	23.6	49.2
		2	471	600	200 200	22.5	49.4
		Mean	468	605	200 800	23.1	49.3
A6	E70T-7(L)W	1	437	584	207 500	24.7	52.2
		2	453	— ⁽³⁾	202 900	7.2 ⁽³⁾	15.2
		Mean	445	584	205 200	24.7	33.7
A7	E70T-7(L)S	1	493	652	245 500	22.9	42.6
		2	473	— ⁽³⁾	213 300	11.8 ⁽³⁾	23.7
		Mean	483	652	229 400	22.9	33.2
A8	E70T7-K2(L)W	1	530	592	199 900	23.9	69.6
		2	523	591	214 200	25.3	68.8
		Mean	527	592	207 100	24.6	69.2
A9	E71T8-K6(H)W	1	413	485	199 400	32.1	71.4
		2	414	494	200 400	23.0	47.9
		Mean	414	490	199 900	27.6	59.7
A10	E71T8-K6(H)S	1	409	495	207 800	25.9	59.0
		2	395	491	206 900	30.8	74.1
		Mean	402	493	207 400	28.4	66.6

- (1) Measured at 0.2% offset
- (2) Measured on 50 mm gauge length
- (3) Specimen fractured prior to reaching ultimate load

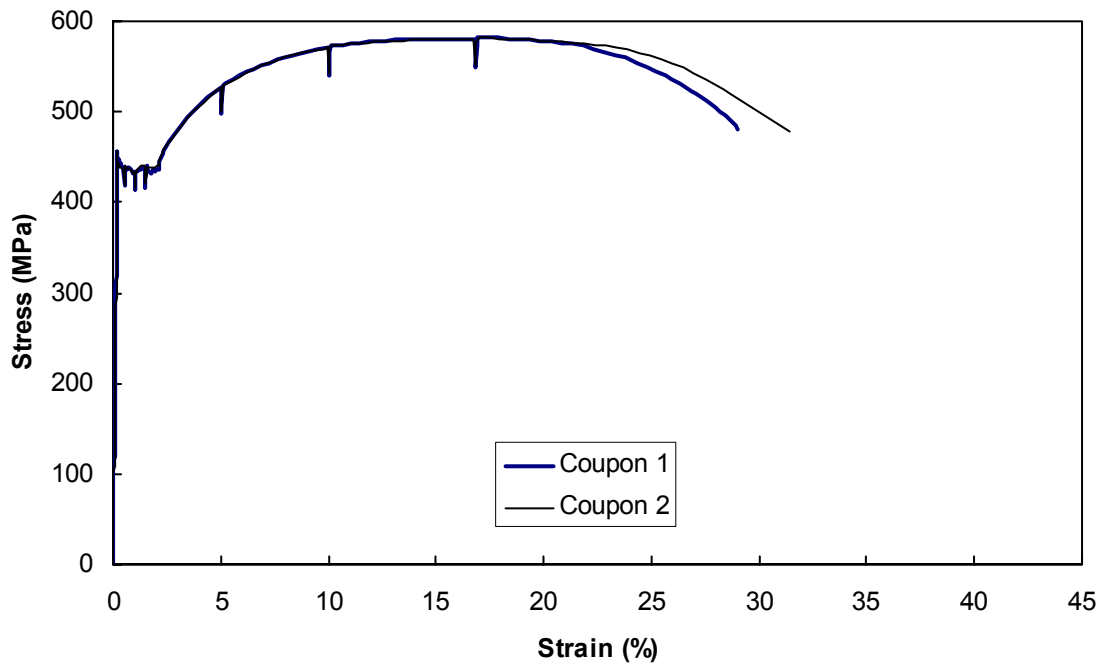

Figure D1 – Stress vs. Strain Curves for 9.5 mm Thick Plate

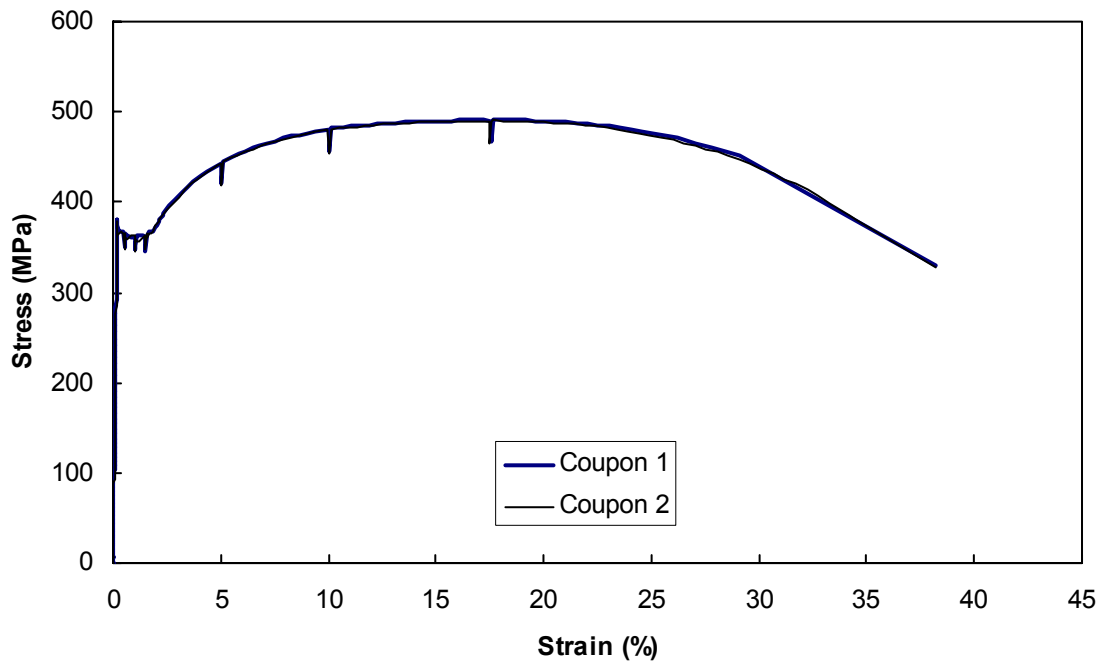

Figure D2 – Stress vs. Strain Curves for 15.9 mm Thick Plate

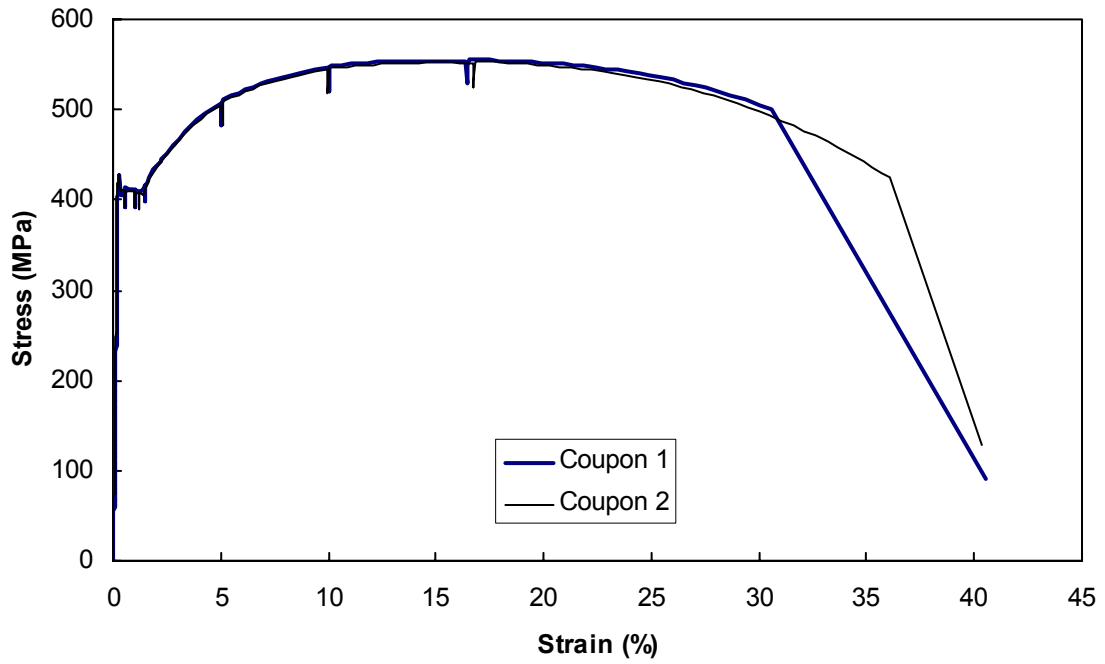

Figure D3 – Stress vs. Strain Curves for 19.1 mm Thick Plate

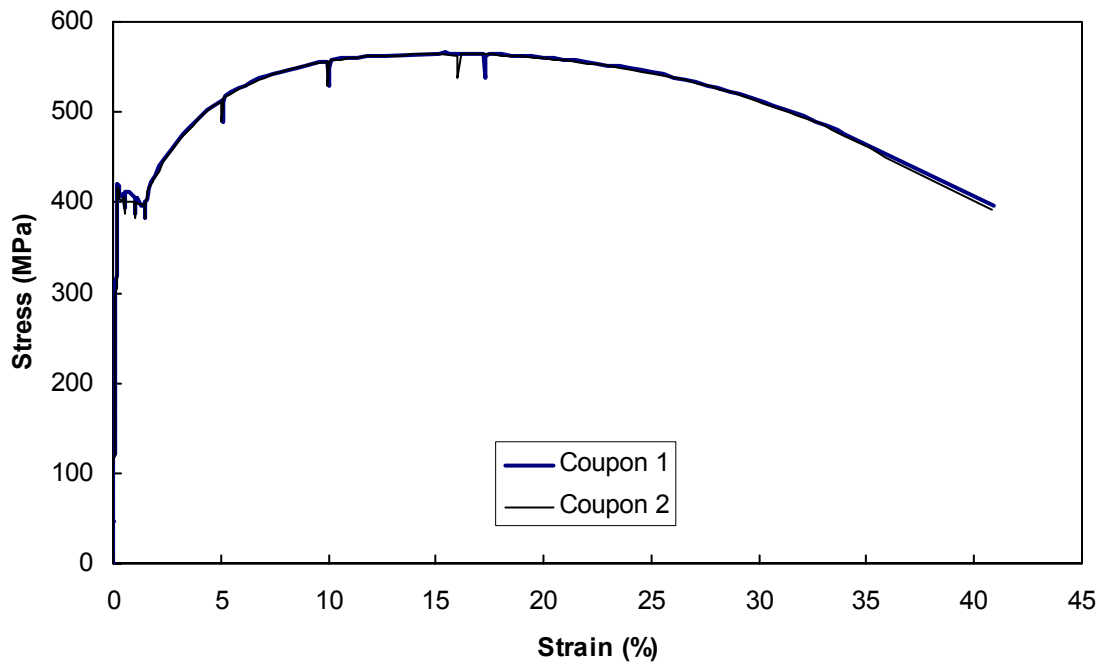

Figure D4 – Stress vs. Strain Curves for 25.4 mm Thick Plate

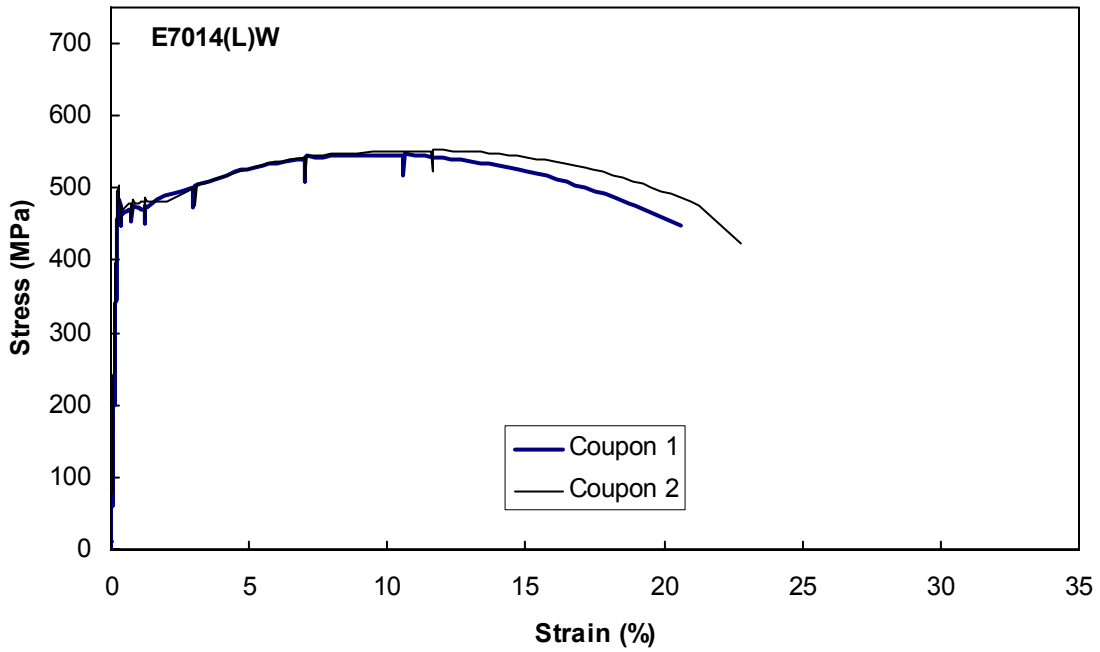

Figure D5 – Stress vs. Strain Curves for Weld Metal Coupons from Assembly A1

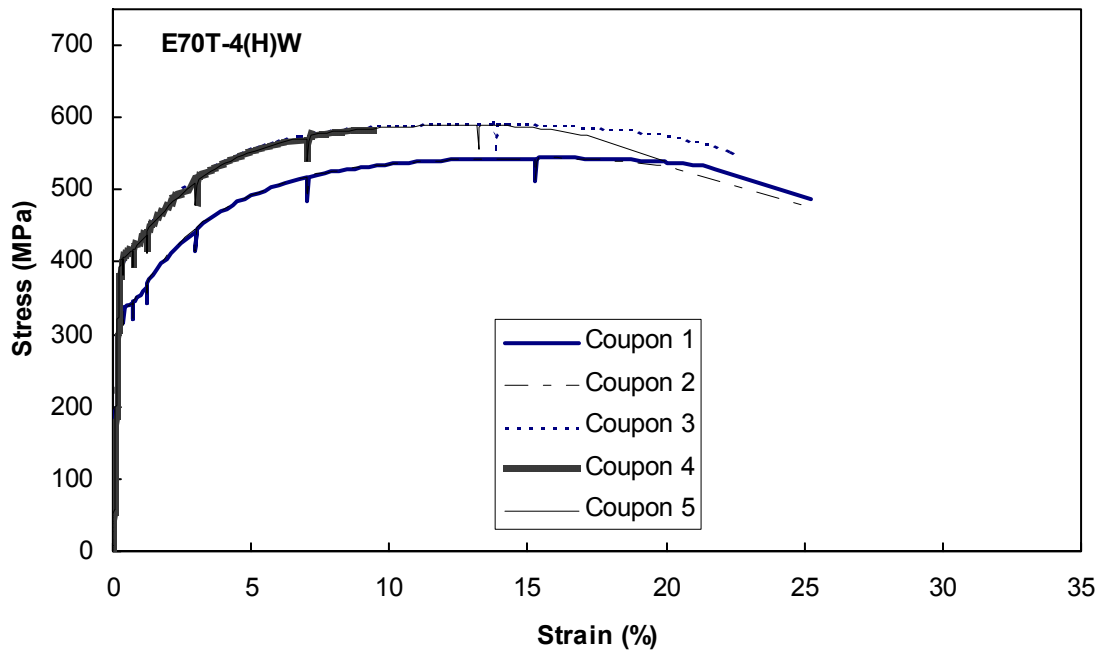

Figure D6 – Stress vs. Strain Curves for Weld Metal Coupons from Assembly A2

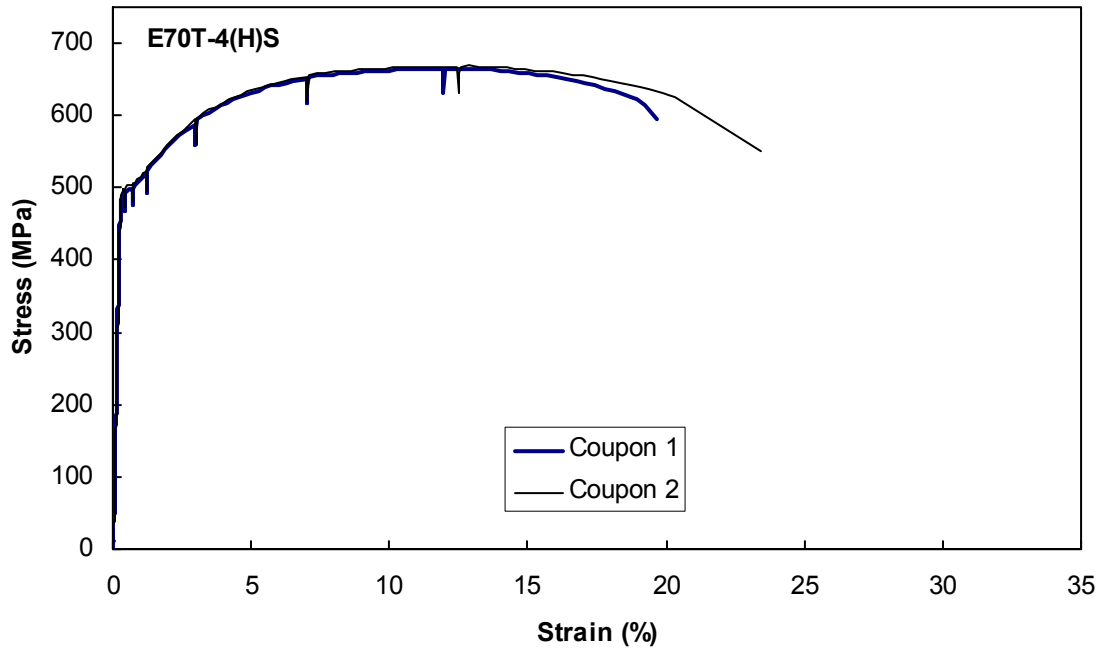

Figure D7 – Stress vs. Strain Curves for Weld Metal Coupons from Assembly A3

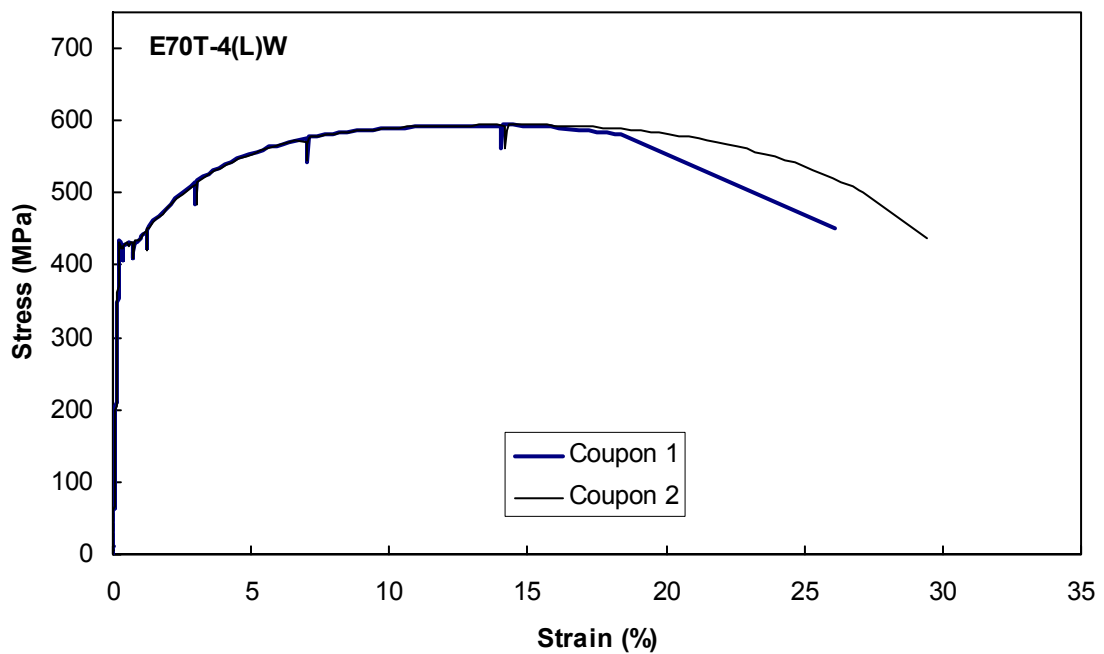

Figure D8 – Stress vs. Strain Curves for Weld Metal Coupons from Assembly A4

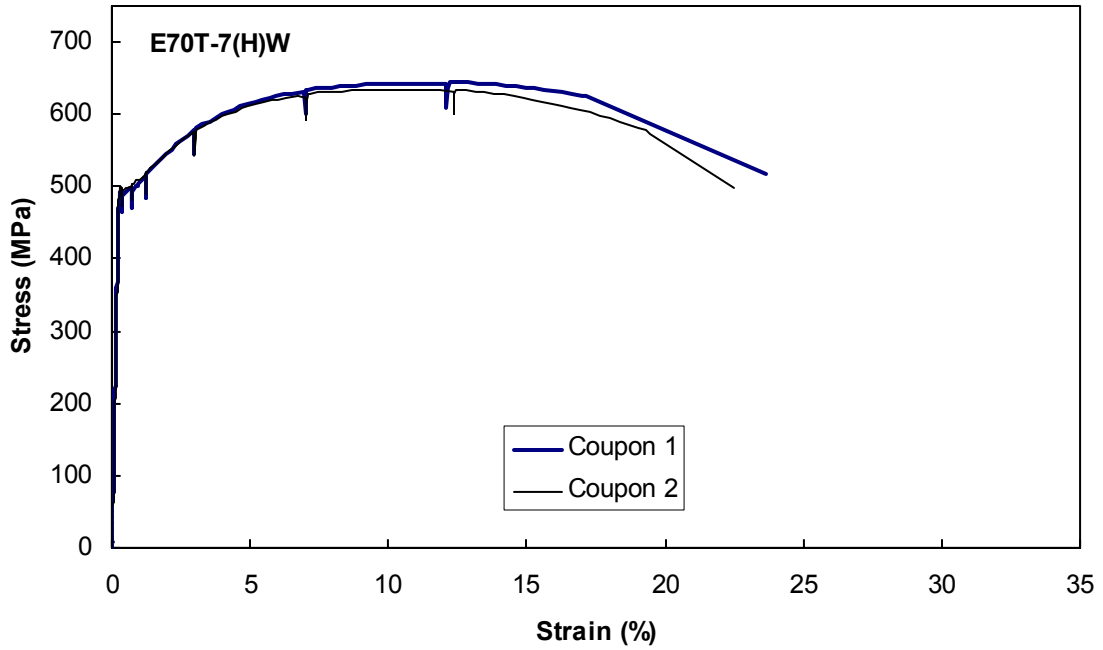

Figure D9 – Stress vs. Strain Curves for Weld Metal Coupons from Assembly A5

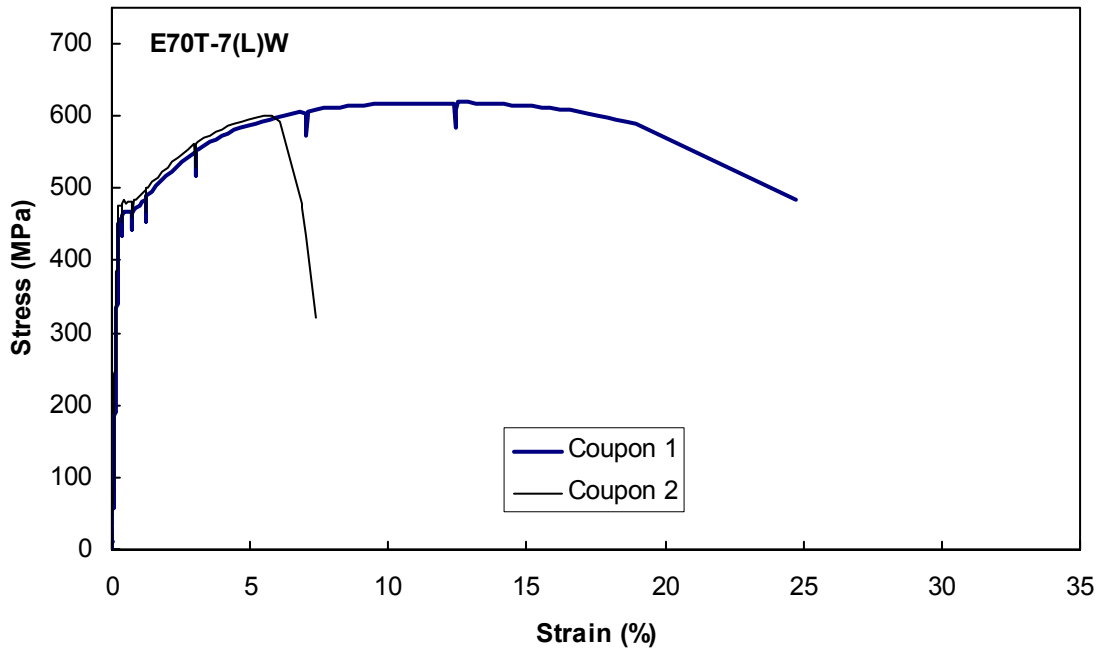

Figure D10 – Stress vs. Strain Curves for Weld Metal Coupons from Assembly A6

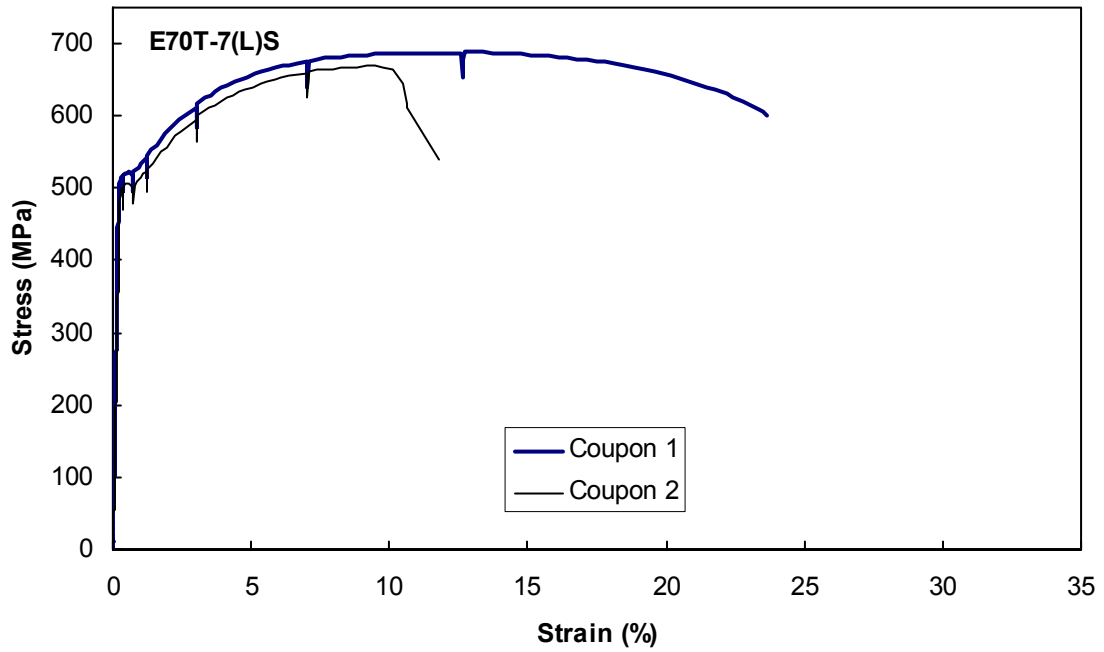

Figure D11 – Stress vs. Strain Curves for Weld Metal Coupons from Assembly A7

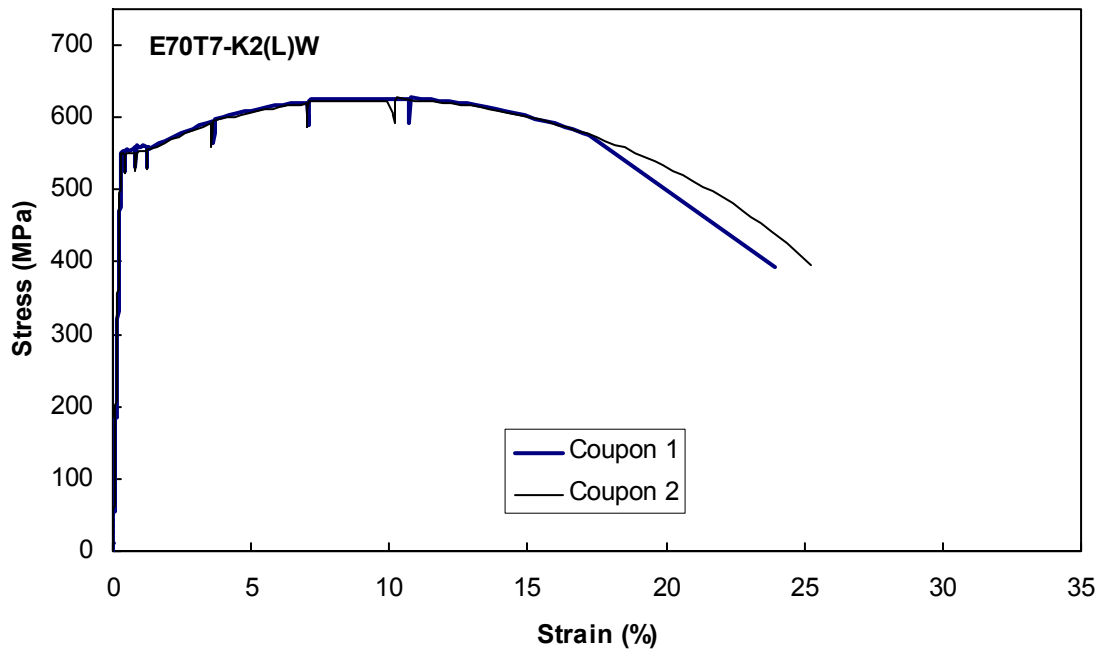

Figure D12 – Stress vs. Strain Curves for Weld Metal Coupons from Assembly A8

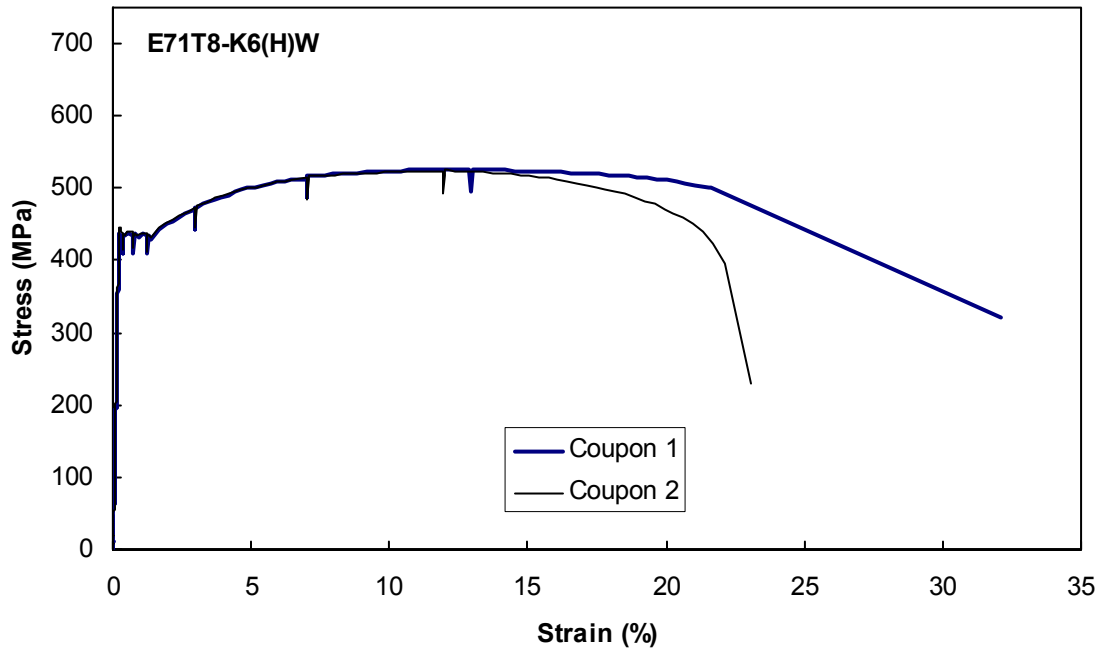

Figure D13 – Stress vs. Strain Curves for Weld Metal Coupons from Assembly A9

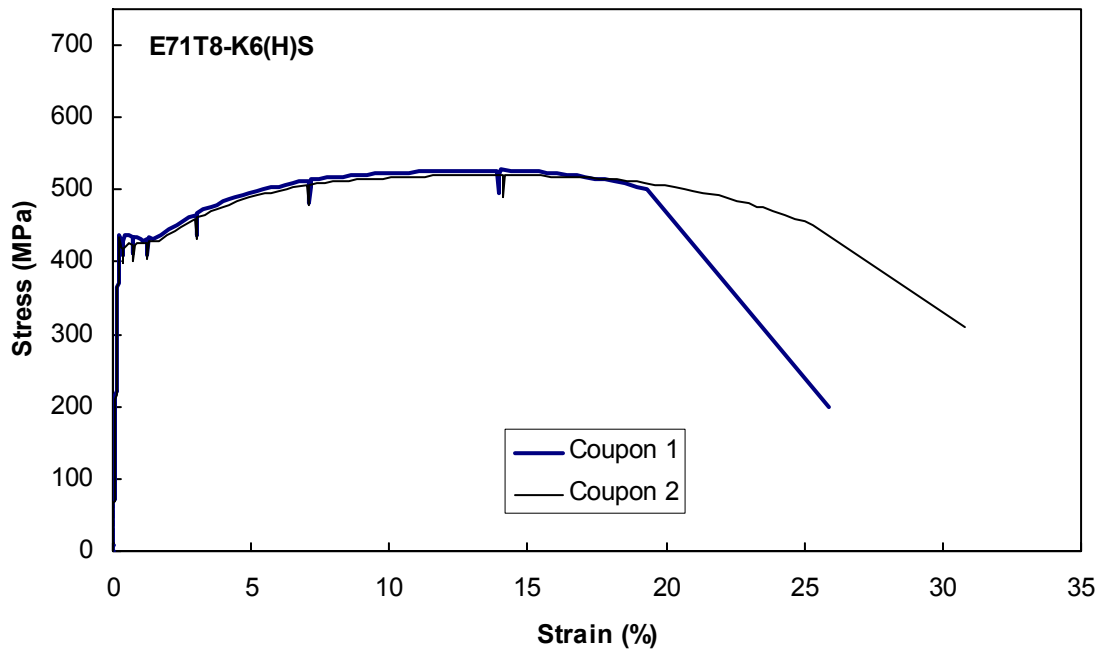

Figure D14 – Stress vs. Strain Curves for Weld Metal Coupons from Assembly A10

APPENDIX E

Transverse Fillet Weld Test Results

APPENDIX E – TRANSVERSE FILLET WELD TEST RESULTS

Explanatory Notes:

- Test/Predicted Ratios are calculated from two different steel design standards: CAN/CSA–S16, Limit States Design of Steel Structures, and AISC Load and Resistance Factor Design Specification for Structural Steel Buildings. Values using both the nominal weld strength and the weld strength measured from weld metal tension coupon tests are shown. The resistance factor is taken equal to 1.0. A more complete description of these calculations, and the rationale on which they are based, can be found in section 4.6 of the main body of the report.
- Effective Throat Area is the product of the minimum theoretical throat dimension, calculated using the mean value of the measurements of each weld leg, and the weld length.
- Fracture Surface Area is the product of the mean fracture surface width, based on measurements at eight locations along the weld, and the weld length.
- Ultimate P/A_{throat} and Ultimate $P/A_{fracture}$ are calculated as one-half of the maximum load applied to the specimen divided by the effective throat area or the fracture surface area, respectively.
- Average Δ/D is the mean value of the two strain measurements on the same weld. The strain is calculated as the LVDT displacement measurement divided by the original gauge length. Results at both the ultimate load and at fracture are reported.
- Fracture Angle is the angle between the fracture surface and the main plate. The reported fracture angles are the mean value of eight measurements along the weld length.
- Maximum Main Plate Stress is the ultimate load divided by the measured cross-sectional area of the main plate.

Table E1 – Lapped Splice Specimen Test Results

Specimen Designation	Weld Size (mm)	Electrode Classification	Electrode Manufacturer	Steel Fabricator	Ultimate Load (kN)	Weld Location	Test/Predicted (S16) Ratio		Test/Predicted (AISC) Ratio		Effective Throat Area - A_{throat} (mm ²)	Ultimate P/A_{throat} (MPa)	Fracture Surface Area - $A_{fracture}$ (mm ²)	Ultimate $P/A_{fracture}$ (MPa)	Average Δ/D (Ultimate Load)	Average Δ/D (Fracture)	Fracture Angle (°)	Maximum Main Plate Stress (MPa)
							Nominal Measured Weld Strength	Ratio	Nominal Measured Weld Strength	Ratio								
T1-1	6.4	E7014	L	W	513	Front	1.51	1.39	1.68	1.55	353	726	387	662	0.08	0.09	12	258
						Back	1.65	1.52	1.84	1.70	322	797	—	—	0.09	—		
T1-2	6.4	E7014	L	W	502	Front	1.52	1.40	1.70	1.57	342	733	383	656	0.08	0.10	8	251
						Back	1.60	1.47	1.78	1.65	326	770	—	—	0.09	0.11		
T1-3	6.4	E7014	L	W	513	Front	1.58	1.46	1.76	1.63	337	761	379	677	0.09	0.10	12	257
						Back	1.57	1.45	1.75	1.61	339	756	417	616	0.10	0.11	7	
T2-1	6.4	E7014	L	W	462	Front	1.52	1.41	1.70	1.57	314	735	321	720	0.10	0.10	9	291
						Back	1.41	1.30	1.57	1.45	341	678	—	—	0.07	0.07	—	
T2-2	6.4	E7014	L	W	474	Front	1.51	1.40	1.69	1.56	325	730	318	746	0.11	0.11	14	298
						Back	1.48	1.37	1.65	1.53	332	714	—	—	0.09	0.09	—	
T2-3	6.4	E7014	L	W	482	Front	1.45	1.34	1.62	1.49	345	699	369	652	0.09	0.10	9	303
						Back	1.53	1.42	1.71	1.58	326	740	—	—	0.07	0.07	—	
T3-1	6.4	E7014	L	W	523	Front	1.44	1.33	1.61	1.48	377	695	360	727	0.10	0.10	15	332
						Back	1.32	1.22	1.48	1.36	410	637	—	—	0.10	0.10	—	
T3-2	6.4	E7014	L	W	518	Front	1.35	1.25	1.51	1.40	396	654	338	766	0.07	0.09	18	331
						Back	1.30	1.20	1.45	1.34	412	628	—	—	0.07	0.07	—	
T3-3	6.4	E7014	L	W	520	Front	1.35	1.24	1.50	1.39	400	650	375	693	0.09	0.09	12	333
						Back	1.37	1.26	1.52	1.41	395	659	—	—	0.48	0.48	—	
T4-1	6.4	E70T-4	H	W	646	Front	2.06	1.74	2.30	1.95	325	994	—	—	0.11	0.11	—	410
						Back	2.04	1.72	2.27	1.93	329	982	651	496	0.08	0.08	0	
T4-2	6.4	E70T-4	H	W	651	Front	2.00	1.69	2.24	1.89	337	966	—	—	0.09	0.09	—	412
						Back	2.02	1.71	2.25	1.91	334	973	679	479	0.07	0.07	0	
T4-3	6.4	E70T-4	H	W	629	Front	1.98	1.68	2.21	1.87	329	956	—	—	0.07	0.07	—	401
						Back	2.01	1.71	2.25	1.90	324	972	663	474	0.08	0.08	0	

Table E1 – Lapped Splice Specimen Test Results (cont.)

Specimen Designation	Weld Size (mm)	Electrode Classification	Electrode Manufacturer	Steel Fabricator	Ultimate Load (kN)	Weld Location	Test/Predicted (S16) Ratio		Test/Predicted (AISC) Ratio		Effective Throat Area - A_{throat} (mm ²)	Ultimate P/A_{throat} (MPa)	Fracture Surface Area - $A_{fracture}$ (mm ²)	Ultimate $P/A_{fracture}$ (MPa)	Average Δ/D (Ultimate Load)	Average Δ/D (Fracture)	Fracture Angle (°)	Maximum Main Plate Stress (MPa)
							Nominal Weld Strength	Measured Weld Strength	Nominal Weld Strength	Measured Weld Strength								
T5-1	6.4	E70T-4	H	W	648	Front	2.06	1.74	2.30	1.94	326	992	—	—	0.07	0.07	—	404
						Back	2.07	1.75	2.31	1.96	325	998	643	504	0.08	0.08	0	
T5-2	6.4	E70T-4	H	W	632	Front	2.00	1.70	2.24	1.90	327	967	—	—	0.04	0.04	—	395
						Back	1.96	1.66	2.18	1.85	335	943	737	429	0.09	0.09	0	
T5-3	6.4	E70T-4	H	W	628	Front	2.01	1.70	2.25	1.90	324	970	—	—	0.04	0.04	—	394
						Back	2.06	1.74	2.30	1.95	316	993	715	439	0.10	0.10	0	
T6-1	6.4	E70T-4	H	W	717	Front	2.44	2.06	2.72	2.30	305	1175	413	869	0.16	0.16	90	459
						Back	2.32	1.97	2.59	2.19	320	1120	—	—	0.12	0.12	—	
T6-2	6.4	E70T-4	H	W	663	Front	2.14	1.81	2.39	2.02	321	1032	—	—	0.08	0.08	—	423
						Back	2.22	1.88	2.48	2.10	309	1073	406	816	0.13	0.13	77	
T6-3	6.4	E70T-4	H	W	741	Front	2.33	1.97	2.60	2.20	330	1124	—	—	0.14	0.14	—	473
						Back	2.43	2.06	2.71	2.30	316	1172	434	854	0.20	0.20	90	
T7-1*	6.4	E70T-4	H	S	679	Front	2.51	2.12	2.80	2.37	281	1209	431	788	0.08	0.08	90	435
						Back	2.30	1.95	2.57	2.18	305	1112	392	866	0.09	0.09	90	
T7-2*	6.4	E70T-4	H	S	601	Front	2.40	2.04	2.68	2.27	259	1160	433	694	0.07	0.07	90	384
						Back	2.31	1.96	2.58	2.18	270	1115	433	694	0.09	0.09	90	
T7-3*	6.4	E70T-4	H	S	627	Front	2.52	2.14	2.82	2.38	258	1217	475	660	0.65	0.65	90	399
						Back	2.36	2.00	2.64	2.23	275	1139	475	660	0.08	0.08	90	
T8-1	6.4	E70T-4	L	W	673	Front	2.02	1.72	2.25	1.92	346	973	Reinforced Weld	—	0.20	—	—	431
						Back	1.86	1.59	2.08	1.78	374	899	Failed	—	0.14	—	—	
T8-2	6.4	E70T-4	L	W	683	Front	1.98	1.69	2.21	1.89	357	956	—	—	0.16	0.17	—	438
						Back	1.93	1.65	2.15	1.84	367	930	581	588	0.20	0.23	6	
T8-3	6.4	E70T-4	L	W	713	Front	1.94	1.65	2.16	1.85	382	934	558	639	0.23	0.24	12	453
						Back	1.95	1.67	2.18	1.86	379	942	—	—	0.16	0.16	—	

* Specimen tested at -50°C

Table E1 – Lapped Splice Specimen Test Results (cont.)

Specimen Designation	Weld Size (mm)	Electrode Classification	Electrode Manufacturer	Steel Fabricator	Ultimate Load (kN)	Weld Location	Test/Predicted (S16) Ratio		Test/Predicted (AISC) Ratio		Effective Throat Area - A_{throat} (mm ²)	Ultimate P/A_{throat} (MPa)	Fracture Surface Area - $A_{fracture}$ (mm ²)	Ultimate $P/A_{fracture}$ (MPa)	Average Δ/D (Ultimate Load)	Average Δ/D (Fracture)	Fracture Angle (°)	Maximum Main Plate Stress (MPa)
							Nominal Weld Strength	Measured Weld Strength	Nominal Weld Strength	Measured Weld Strength								
T9-1	6.4	E70T-4	L	S	806	Front	2.35	2.01	2.63	2.24	355	1135	—	—	0.19	0.19	—	507
						Back	2.28	1.94	2.54	2.17	367	1098	457	882	0.15	0.15	40	
T9-2	6.4	E70T-4	L	S	809	Front	2.37	2.02	2.65	2.26	354	1143	—	—	0.19	0.18	—	510
						Back	2.25	1.92	2.51	2.14	373	1084	522	775	0.19	0.19	27	
T9-3	6.4	E70T-4	L	S	829	Front	2.30	1.97	2.57	2.20	373	1111	498	833	0.24	0.24	25	523
						Back	2.32	1.98	2.59	2.21	370	1120	—	—	0.21	0.21	—	
T10-1	6.4	E70T-4	L	S	740	Front	2.01	1.72	2.25	1.92	381	970	501	739	0.10	0.12	23	373
						Back	1.92	1.64	2.14	1.83	400	925	—	—	0.06	0.06	—	
T10-2	6.4	E70T-4	L	S	794	Front	2.20	1.88	2.46	2.10	374	1063	—	—	0.12	0.13	—	401
						Back	2.17	1.86	2.43	2.07	379	1049	547	725	0.11	0.13	14	
T10-3	6.4	E70T-4	L	S	757	Front	2.11	1.80	2.35	2.01	373	1016	—	—	0.11	0.11	27	383
						Back	1.97	1.69	2.20	1.88	398	952	487	777	0.06	0.06	—	
T11-1	6.4	E70T-7	H	W	695	Front	2.05	1.62	2.28	1.81	352	987	691	503	0.13	0.16	0	438
						Back	1.86	1.48	2.08	1.65	387	898	—	—	0.09	0.09	—	
T11-2	6.4	E70T-7	H	W	680	Front	1.89	1.50	2.11	1.68	372	914	—	—	0.08	0.08	—	437
						Back	1.89	1.50	2.11	1.67	373	912	735	463	0.08	0.08	0	
T11-3	6.4	E70T-7	H	W	655	Front	1.85	1.47	2.06	1.64	368	891	642	510	0.09	0.09	0	411
						Back	1.80	1.43	2.02	1.60	376	871	—	—	0.06	0.06	—	
T12-1	6.4	E70T-7	H	S	745	Front	2.07	1.64	2.31	1.83	373	999	—	—	0.09	0.09	—	467
						Back	2.29	1.82	2.56	2.03	337	1106	436	854	0.12	0.12	76	
T12-2	6.4	E70T-7	H	S	769	Front	2.21	1.75	2.47	1.96	361	1066	—	—	0.10	0.10	—	483
						Back	2.46	1.95	2.75	2.18	324	1188	394	976	0.12	0.12	71	
T12-3	6.4	E70T-7	H	S	783	Front	2.23	1.77	2.49	1.98	363	1078	461	849	0.16	0.16	90	490
						Back	2.35	1.87	2.63	2.08	345	1135	—	—	0.15	0.15	—	

Table E1 – Lapped Splice Specimen Test Results (cont.)

Specimen Designation	Weld Size (mm)	Electrode Classification	Electrode Manufacturer	Steel Fabricator	Ultimate Load (kN)	Weld Location	Test/Predicted (S16) Ratio		Test/Predicted (AISC) Ratio		Effective Throat Area - A_{throat} (mm ²)	Ultimate P/A_{throat} (MPa)	Fracture Surface Area - $A_{fracture}$ (mm ²)	Ultimate $P/A_{fracture}$ (MPa)	Average Δ/D (Ultimate Load) (Fracture)	Average Δ/D (Fracture)	Fracture Angle (°)	Maximum Main Plate Stress (MPa)
							Nominal Weld Strength	Measured Weld Strength	Nominal Weld Strength	Measured Weld Strength								
T13-1	6.4	E70T-7	L	W	607	Front	2.01	1.56	2.25	1.74	313	971	370	821	0.06	0.07	90	384
						Back	1.75	1.36	1.96	1.52	359	845	—	0.04	0.06	—	—	
T13-2	6.4	E70T-7	L	W	689	Front	2.12	1.65	2.37	1.84	336	1024	Reinforced	—	0.14	—	—	434
						Back	2.04	1.59	2.28	1.77	349	986	Weld Failed	—	0.13	—	—	
T13-3	6.4	E70T-7	L	W	605	Front	1.98	1.54	2.22	1.72	316	957	528	572	0.05	0.19	49	384
						Back	2.07	1.61	2.32	1.80	302	1000	—	0.07	0.12	—	—	
T14-1	6.4	E70T-7	L	S	769	Front	2.01	1.56	2.24	1.74	396	970	—	—	0.10	0.10	—	481
						Back	1.94	1.51	2.17	1.68	411	936	722	0.08	0.08	6	—	
T14-2	6.4	E70T-7	L	S	778	Front	2.02	1.57	2.26	1.75	399	976	—	—	0.13	0.13	—	509
						Back	1.99	1.54	2.22	1.72	406	959	723	0.11	0.13	8	—	
T14-3	6.4	E70T-7	L	S	709	Front	1.86	1.44	2.07	1.61	396	895	722	491	0.10	0.10	4	442
						Back	1.85	1.44	2.07	1.61	397	894	—	0.08	0.08	—	—	
T15-1	6.4	E70T-7	L	S	781	Front	2.23	1.73	2.49	1.93	364	1074	722	541	0.06	0.06	0	395
						Back	2.08	1.62	2.32	1.81	389	1004	—	0.04	0.04	—	—	
T15-2	6.4	E70T-7	L	S	760	Front	1.99	1.55	2.23	1.73	395	962	760	500	0.07	0.07	0	384
						Back	1.96	1.52	2.18	1.70	403	944	—	0.05	0.05	—	—	
T15-3	6.4	E70T-7	L	S	766	Front	2.09	1.62	2.33	1.81	380	1007	706	542	0.06	0.06	0	386
						Back	2.03	1.58	2.27	1.76	391	980	—	0.04	0.04	—	—	
T16-1	6.4	E70T7-K2	L	W	769	Front	2.14	1.74	2.39	1.94	372	1034	—	—	0.27	0.27	-	481
						Back	1.94	1.57	2.17	1.76	411	936	550	0.31	0.34	18	—	
T16-2	6.4	E70T7-K2	L	W	782	Front	2.22	1.80	2.47	2.01	366	1069	Lap Plate Failed	—	0.25	—	—	491
						Back	1.88	1.52	2.10	1.70	431	907	—	0.20	—	—	—	
T16-3	6.4	E70T7-K2	L	W	658	Front	1.92	1.56	2.15	1.74	355	928	—	—	0.16	0.16	—	439
						Back	1.97	1.60	2.20	1.79	345	952	478	0.22	0.24	21	—	

Table E1 – Lapped Splice Specimen Test Results (cont.)

Specimen Designation	Weld Size (mm)	Electrode Classification	Electrode Manufacturer	Steel Fabricator	Ultimate Load (kN)	Weld Location	Test/Predicted (S16) Ratio		Test/Predicted (AISC) Ratio		Effective Throat Area - A_{throat} (mm ²)	Ultimate P/A_{throat} (MPa)	Fracture Surface Area - $A_{fracture}$ (mm ²)	Ultimate $P/A_{fracture}$ (MPa)	Average Δ/D (Ultimate Load)	Average Δ/D (Fracture)	Fracture Angle (°)	Maximum Main Plate Stress (MPa)
							Nominal Weld Strength	Measured Weld Strength	Nominal Weld Strength	Measured Weld Strength								
T17-1	6.4	E70T7-K2	L	S	777	Front	2.40	1.95	2.68	2.17	335	1158	410	947	0.12	0.12	64	491
						Back	2.27	1.84	2.54	2.06	355	1095	—	—	0.12	0.12	—	—
T17-2	6.4	E70T7-K2	L	S	715	Front	2.53	2.05	2.83	2.29	293	1222	292	1222	0.05	0.05	90	451
						Back	1.87	1.52	2.09	1.70	396	904	—	—	0.06	0.06	—	—
T17-3	6.4	E70T7-K2	L	S	721	Front	2.45	1.98	2.73	2.22	305	1180	307	1175	0.10	0.10	90	453
						Back	1.90	1.54	2.12	1.72	393	917	—	—	0.08	0.08	—	—
T18-1	6.4	E71T8-K6	H	W	711	Front	2.30	2.25	2.57	2.51	320	1110	726	490	0.41	0.42	0	449
						Back	2.29	2.23	2.55	2.49	322	1103	—	—	0.23	0.25	—	—
T18-2	6.4	E71T8-K6	H	W	699	Front	2.29	2.24	2.56	2.50	316	1107	—	—	0.45	0.46	—	443
						Back	2.39	2.33	2.67	2.61	303	1153	670	522	0.30	0.31	0	—
T18-3	6.4	E71T8-K6	H	W	711	Front	2.19	2.13	2.44	2.38	337	1054	—	—	0.40	0.40	—	449
						Back	2.38	2.32	2.66	2.59	310	1148	654	543	0.31	0.32	0	—
T19-1	6.4	E71T8-K6	H	S	780	Front	2.02	1.97	2.26	2.20	400	975	—	—	0.15	0.15	—	490
						Back	2.08	2.03	2.32	2.27	389	1003	481	810	0.17	0.17	24	—
T19-2	6.4	E71T8-K6	H	S	784	Front	1.87	1.82	2.09	2.04	435	901	—	—	0.15	0.15	—	493
						Back	2.22	2.17	2.48	2.42	366	1070	484	810	0.20	0.20	26	—
T19-3	6.4	E71T8-K6	H	S	744	Front	1.83	1.78	2.04	1.99	422	882	—	—	0.15	0.15	—	468
						Back	2.06	2.01	2.30	2.25	374	995	502	741	0.19	0.19	25	—
T20-1	12.7	E7014	L	W	782	Front	1.09	1.01	1.22	1.13	741	528	767	510	0.13	0.15	27	396
						Back	1.12	1.03	1.25	1.15	724	540	—	—	0.05	0.06	—	—
T20-2	12.7	E7014	L	W	949	Front	1.41	1.30	1.58	1.46	697	681	1040	456	0.17	0.19	7	481
						Back	1.31	1.21	1.47	1.35	749	633	—	—	0.13	0.13	—	—
T20-3	12.7	E7014	L	W	878	Front	1.24	1.14	1.38	1.27	736	596	946	464	0.13	0.15	7	443
						Back	1.23	1.14	1.37	1.27	739	594	—	—	0.09	0.09	—	—

Table E1 – Lapped Splice Specimen Test Results (cont.)

Specimen Designation	Weld Size (mm)	Electrode Classification	Electrode Manufacturer	Steel Fabricator	Ultimate Load (kN)	Weld Location	Test/Predicted (S16) Ratio		Test/Predicted (AISC) Ratio		Effective Throat Area - A_{throat} (mm ²)	Ultimate P/A_{throat} (MPa)	Fracture Surface Area - $A_{fracture}$ (mm ²)	Ultimate $P/A_{fracture}$ (MPa)	Average Δ/D (Ultimate Load)	Average Δ/D (Fracture)	Fracture Angle (°)	Maximum Main Plate Stress (MPa)
							Nominal Weld Strength	Measured Weld Strength	Nominal Weld Strength	Measured Weld Strength								
T21-1	12.7	E70T-4	H	W	996	Front	1.54	1.30	1.72	1.45	671	742	1033	482	0.16	0.18	0	499
						Back	1.51	1.28	1.69	1.43	682	731	—	—	0.11	0.12	—	
T21-2	12.7	E70T-4	H	W	981	Front	1.46	1.24	1.63	1.38	697	704	—	—	0.10	0.10	—	494
						Back	1.48	1.25	1.65	1.39	689	712	1139	431	0.14	0.15	0	
T21-3	12.7	E70T-4	H	W	921	Front	1.39	1.17	1.55	1.31	688	669	—	—	0.08	0.09	—	463
						Back	1.39	1.18	1.55	1.31	687	670	1105	417	0.10	0.13	0	
T22-1	12.7	E70T-4	H	S	912	Front	1.76	1.49	1.96	1.66	538	848	928	491	0.13	0.15	0	460
						Back	1.53	1.30	1.71	1.45	617	739	—	—	0.08	0.08	—	
T22-2	12.7	E70T-4	H	S	903	Front	1.71	1.45	1.91	1.61	548	823	966	467	0.11	0.13	0	455
						Back	1.56	1.32	1.74	1.47	601	752	—	—	0.08	0.08	—	
T22-3	12.7	E70T-4	H	S	994	Front	1.81	1.54	2.03	1.71	568	875	983	506	0.16	0.17	0	481
						Back	1.78	1.50	1.98	1.68	580	857	—	—	0.14	0.14	—	
T23-1	12.7	E70T-4	L	W	966	Front	2.02	1.72	2.25	1.92	683	707	945	511	0.19	0.21	13	488
						Back	1.86	1.59	2.08	1.78	712	678	—	—	0.12	0.13	—	
T23-2	12.7	E70T-4	L	W	920	Front	1.98	1.69	2.21	1.89	677	679	928	495	0.14	0.16	14	465
						Back	1.93	1.65	2.15	1.84	710	648	—	—	0.08	0.08	—	
T23-3	12.7	E70T-4	L	W	919	Front	1.94	1.65	2.16	1.85	697	659	874	526	0.14	0.15	17	464
						Back	1.95	1.67	2.18	1.86	696	660	—	—	0.10	0.10	—	
T24-1	12.7	E70T-4	L	S	1014	Front	2.35	2.01	2.63	2.24	605	838	—	—	0.17	0.18	—	513
						Back	2.28	1.94	2.54	2.17	634	799	729	696	0.20	0.21	22	
T24-2	12.7	E70T-4	L	S	1020	Front	2.37	2.02	2.65	2.26	614	830	—	—	0.15	0.15	—	516
						Back	2.25	1.92	2.51	2.14	630	810	751	679	0.24	0.24	22	
T24-3	12.7	E70T-4	L	S	995	Front	2.30	1.97	2.57	2.20	634	785	797	624	0.14	0.14	17	503
						Back	2.32	1.98	2.59	2.21	621	801	—	—	0.15	0.15	—	

Table E1 – Lapped Splice Specimen Test Results (cont.)

Specimen Designation	Weld Size (mm)	Electrode Classification	Electrode Manufacturer	Steel Fabricator	Ultimate Load (kN)	Weld Location	Test/Predicted (S16) Ratio		Test/Predicted (AISC) Ratio		Effective Throat Area - A_{throat} (mm ²)	Ultimate P/A_{throat} (MPa)	Fracture Surface Area - $A_{fracture}$ (mm ²)	Ultimate $P/A_{fracture}$ (MPa)	Average Δ/D (Ultimate Load)	Average Δ/D (Fracture)	Fracture Angle (°)	Maximum Main Plate Stress (MPa)
							Nominal Weld Strength	Measured Weld Strength	Nominal Weld Strength	Measured Weld Strength								
T25-1	12.7	E70T-7	H	W	1040	Front	1.62	1.28	1.80	1.43	667	780	Reinforced Weld	—	0.10	—	—	525
						Back	1.64	1.30	1.83	1.45	657	791	Failed	—	0.10	—	—	—
T25-2	12.7	E70T-7	H	W	999	Front	1.60	1.27	1.79	1.42	648	771	1161	430	0.11	0.11	0	504
						Back	1.62	1.28	1.80	1.43	641	779	—	—	0.11	0.11	—	—
T25-3	12.7	E70T-7	H	W	1020	Front	1.57	1.24	1.75	1.39	674	756	—	—	0.11	0.11	—	515
						Back	1.65	1.31	1.84	1.46	641	795	966	528	0.14	0.15	11	—
T26-1	12.7	E70T-7	H	S	1060	Front	1.70	1.35	1.90	1.51	645	822	749	708	0.17	0.17	—	536
						Back	1.74	1.38	1.95	1.55	630	842	—	—	0.17	0.17	24	—
T26-2	12.7	E70T-7	H	S	1068	Front	1.70	1.35	1.90	1.51	651	821	—	—	0.20	0.21	23	541
						Back	1.73	1.37	1.94	1.54	639	836	868	615	0.16	0.16	—	—
T26-3	12.7	E70T-7	H	S	1062	Front	1.67	1.32	1.86	1.48	661	804	—	—	0.22	0.22	24	537
						Back	1.67	1.33	1.87	1.48	658	807	787	675	0.13	0.13	—	—
T27-1	12.7	E70T-7	L	W	841	Front	1.34	1.04	1.50	1.16	650	647	718	586	0.09	0.10	25	423
						Back	1.37	1.07	1.53	1.19	635	662	—	—	0.06	0.07	—	—
T27-2	12.7	E70T-7	L	W	943	Front	1.49	1.16	1.66	1.29	656	719	—	—	0.11	0.11	—	473
						Back	1.53	1.18	1.70	1.32	641	736	712	662	0.12	0.13	13	—
T27-3	12.7	E70T-7	L	W	945	Front	1.50	1.17	1.68	1.30	652	725	—	—	0.12	0.12	—	416
						Back	1.55	1.20	1.73	1.35	631	748	751	630	0.08	0.08	13	—
T28-1	12.7	E70T-7	L	S	990	Front	1.61	1.25	1.79	1.39	639	775	782	633	0.14	0.14	19	500
						Back	1.66	1.29	1.85	1.44	619	800	—	—	0.11	0.11	—	—
T28-2	12.7	E70T-7	L	S	999	Front	1.63	1.27	1.82	1.42	634	788	—	—	0.12	0.12	—	504
						Back	1.68	1.30	1.87	1.46	617	810	1132	441	0.12	0.12	0	—
T28-3	12.7	E70T-7	L	S	991	Front	1.59	1.23	1.77	1.38	647	766	—	—	0.10	0.10	—	500
						Back	1.62	1.26	1.81	1.40	635	781	1214	408	0.11	0.12	0	—

Table E1 – Lapped Splice Specimen Test Results (cont.)

Specimen Designation	Weld Size (mm)	Electrode Classification	Electrode Manufacturer	Steel Fabricator	Ultimate Load (kN)	Weld Location	Test/Predicted (S16) Ratio		Test/Predicted (AISC) Ratio		Effective Throat Area - A_{throat} (mm ²)	Ultimate P/A_{throat} (MPa)	Fracture Surface Area - $A_{fracture}$ (mm ²)	Ultimate $P/A_{fracture}$ (MPa)	Average Δ/D (Ultimate Load)	Average Δ/D (Fracture)	Fracture Angle (°)	Maximum Main Plate Stress (MPa)
							Nominal Measured Weld Strength	Measured Weld Strength	Nominal Measured Weld Strength	Measured Weld Strength								
T29-1	12.7	E70T7-K2	L	W	1083	Front	1.69	1.37	1.88	1.53	666	813	Main Plate	—	0.17	—	—	547
						Back	1.48	1.20	1.65	1.34	758	714	Failed	—	0.14	—		
T29-2	12.7	E70T7-K2	L	W	1073	Front	1.58	1.28	1.76	1.43	705	761	Main Plate	—	0.19	—	—	543
						Back	1.48	1.20	1.65	1.34	751	714	Failed	—	0.15	—		
T29-3	12.7	E70T7-K2	L	W	1082	Front	1.54	1.25	1.72	1.39	729	742	Main Plate	—	0.20	—	—	547
						Back	1.54	1.25	1.72	1.40	727	744	Failed	—	0.20	—		
T30-1	12.7	E70T7-K2	L	S	1057	Front	1.71	1.39	1.92	1.55	639	827	Main Plate	—	0.22	—	—	532
						Back	1.78	1.44	1.98	1.61	617	856	Failed	—	0.18	—		
T30-2	12.7	E70T7-K2	L	S	1073	Front	1.83	1.48	2.04	1.65	609	881	—	—	0.24	0.25	—	542
						Back	1.86	1.51	2.07	1.68	599	896	777	690	0.19	0.20	19	
T30-3	12.7	E70T7-K2	L	S	1056	Front	1.81	1.47	2.03	1.64	603	875	737	716	0.25	0.25	21	534
						Back	1.78	1.44	1.99	1.61	615	858	—	—	0.20	0.20	—	
T31-1	12.7	E71T8-K6	H	W	1036	Front	1.80	1.76	2.01	1.97	596	869	—	—	0.22	0.23	—	522
						Back	1.76	1.72	1.96	1.92	611	847	1116	464	0.27	0.29	0	
T31-2	12.7	E71T8-K6	H	W	1004	Front	1.67	1.63	1.86	1.82	624	805	—	—	0.17	0.18	—	507
						Back	1.70	1.66	1.90	1.86	611	822	1092	459	0.23	0.26	0	
T31-3	12.7	E71T8-K6	H	W	1014	Front	1.65	1.61	1.84	1.80	637	796	—	—	0.19	0.21	—	511
						Back	1.80	1.76	2.01	1.97	583	870	1051	482	0.21	0.25	0	
T32-1	12.7	E71T8-K6	H	S	1044	Front	1.72	1.68	1.92	1.87	630	829	—	—	0.21	0.21	—	528
						Back	1.62	1.58	1.80	1.76	670	779	811	644	0.27	0.23	25	
T32-2	12.7	E71T8-K6	H	S	1049	Front	1.75	1.71	1.96	1.91	620	846	—	—	0.27	0.28	—	530
						Back	1.64	1.60	1.83	1.78	665	789	776	676	0.24	0.26	23	
T32-3	12.7	E71T8-K6	H	S	1022	Front	1.72	1.68	1.92	1.87	617	828	876	583	0.30	0.31	10	516
						Back	1.57	1.54	1.76	1.72	673	759	—	—	0.18	0.19	—	

Table E2 – Cruciform Specimen Test Results

Specimen Designation	Weld Size (mm)	Electrode Classification	Electrode Manufacturer	Steel Fabricator	Ultimate Load (kN)	Weld Location	Test/Predicted (S16) Ratio		Test/Predicted (AISC) Ratio		Effective Throat Area - A_{throat} (mm ²)	Ultimate P/A_{throat} (MPa)	Fracture Surface Area - $A_{fracture}$ (mm ²)	Ultimate $P/A_{fracture}$ (MPa)	Average Δ/D (Ultimate Load)	Average Δ/D (Fracture)	Fracture Angle (°)	Maximum Main Plate Stress (MPa)
							Nominal Weld Strength	Measured Weld Strength	Nominal Weld Strength	Measured Weld Strength								
C1-1	6.4	E70T-4	H	W	672	Front	2.21	1.89	2.47	2.11	315	1067	573	586	0.05	0.05	15	422
						Back	1.91	1.63	2.14	1.82	364	923	—	—	—	—	—	
C1-2	6.4	E70T-4	H	W	658	Front	2.13	1.82	2.38	2.03	320	1028	590	558	0.02	0.02	0	410
						Back	1.81	1.55	2.02	1.73	376	874	—	—	—	—	—	
C1-3	6.4	E70T-4	H	W	600	Front	1.95	1.67	2.18	1.86	318	943	518	580	0.01	0.01	0	380
						Back	1.69	1.44	1.88	1.61	369	814	—	—	—	—	—	
C2-1	6.4	E70T7-K2	L	W	650	Front	2.07	1.68	2.31	1.87	326	997	451	720	0.08	0.08	15	422
						Back	1.82	1.48	2.03	1.65	370	878	—	—	—	—	—	
C2-2	6.4	E70T7-K2	L	W	655	Front	1.94	1.57	2.17	1.76	350	937	—	—	0.02	0.02	—	410
						Back	1.98	1.60	2.21	1.79	343	954	430	762	—	—	—	
C2-3	6.4	E70T7-K2	L	W	618	Front	1.89	1.53	2.11	1.71	339	911	—	—	-0.01	-0.01	—	380
						Back	1.82	1.47	2.03	1.65	352	877	456	677	0.05	0.05	0	

Appendix F

Transverse Fillet Weld Stress vs. Strain Response

Appendix F – Transverse Fillet Weld Stress vs. Strain Response

Figure F0 shows a sample stress vs. strain plot for the transverse fillet weld test specimens. A description of several key elements of the plots, identified by number, is provided below.

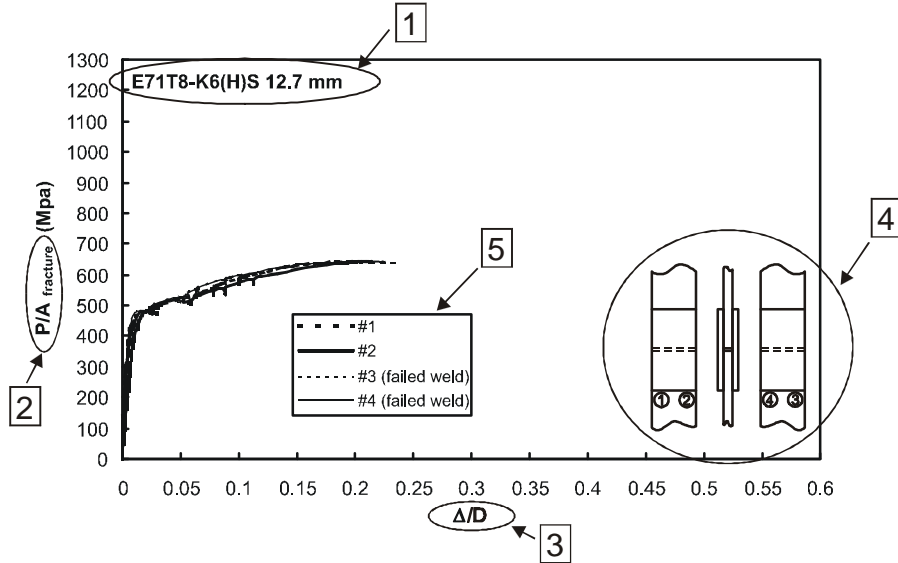
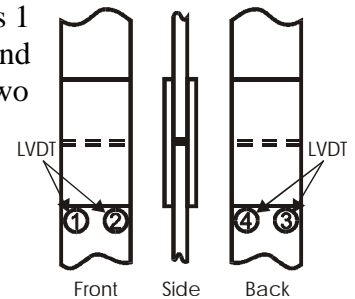

Figure F0 – Sample Stress vs. Strain Plot

1. The elements of the specimen identifier nomenclature are described in chapter 1 of the main body of the report.
2. The subscripts indicate upon which area the plotted stress values are based. In general, the area is that of the measured fracture surface, which accounts for both weld penetration and reinforcement. It is implicitly assumed that the test weld that did not fail would have had a fracture surface with a similar area. In the few cases where the base plate fractured just prior to reaching the weld capacity, the area of the theoretical throat, based upon the measured weld leg sizes, is substituted. Stresses measured in these two different ways cannot be compared directly.
3. The weld strain was calculated as the measured weld deformation, Δ , divided by the initial measured weld leg size, D .
4. The diagram shows the locations of the LVDTs. LVDTs 1 and 2 are at the front of the test specimen and LVDTs 3 and 4 are at the back. Some cruciform specimens had only two LVDTs that were located at the sides of the specimen to eliminate the effects of bending. See section 3.2.2 of the main body of the report for details.
5. The legend identifies for each curve the location where displacements were measured and indicates where failure took place.



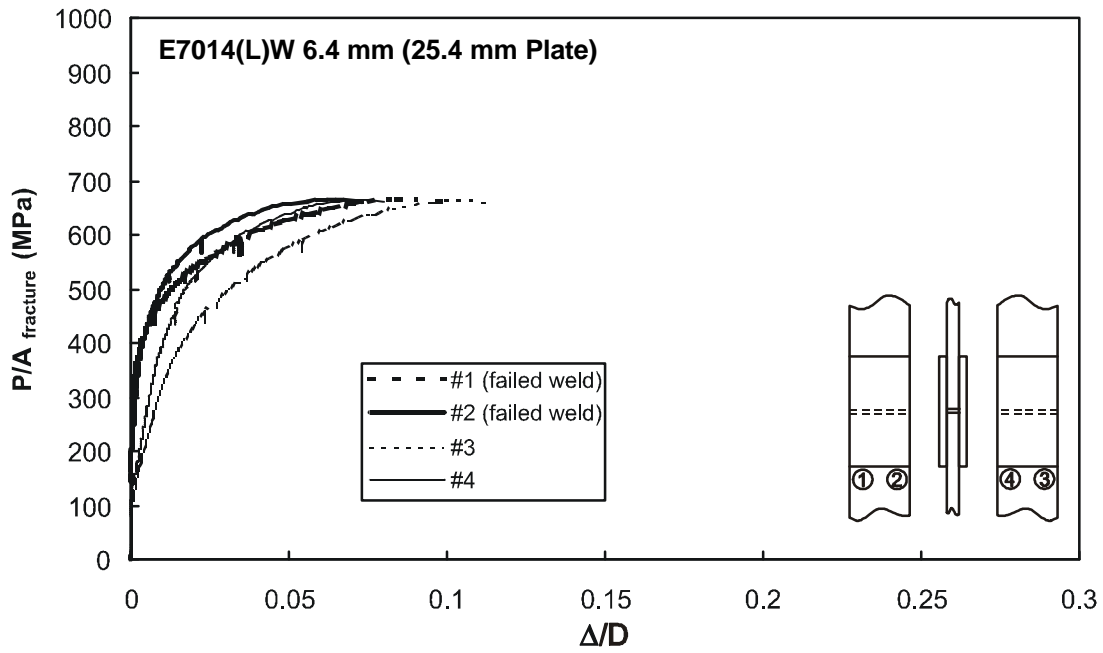

Figure F1 – Specimen T1-1 with 6.4 mm weld from E7014 electrode

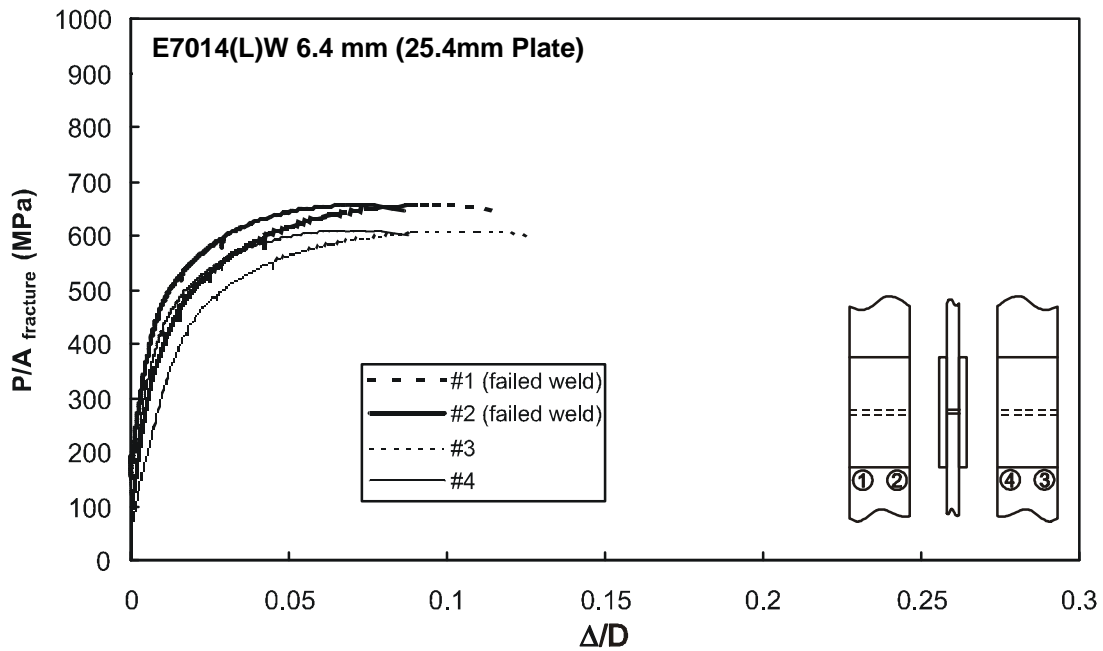

Figure F2 – Specimen T1-2 with 6.4 mm weld from E7014 electrode

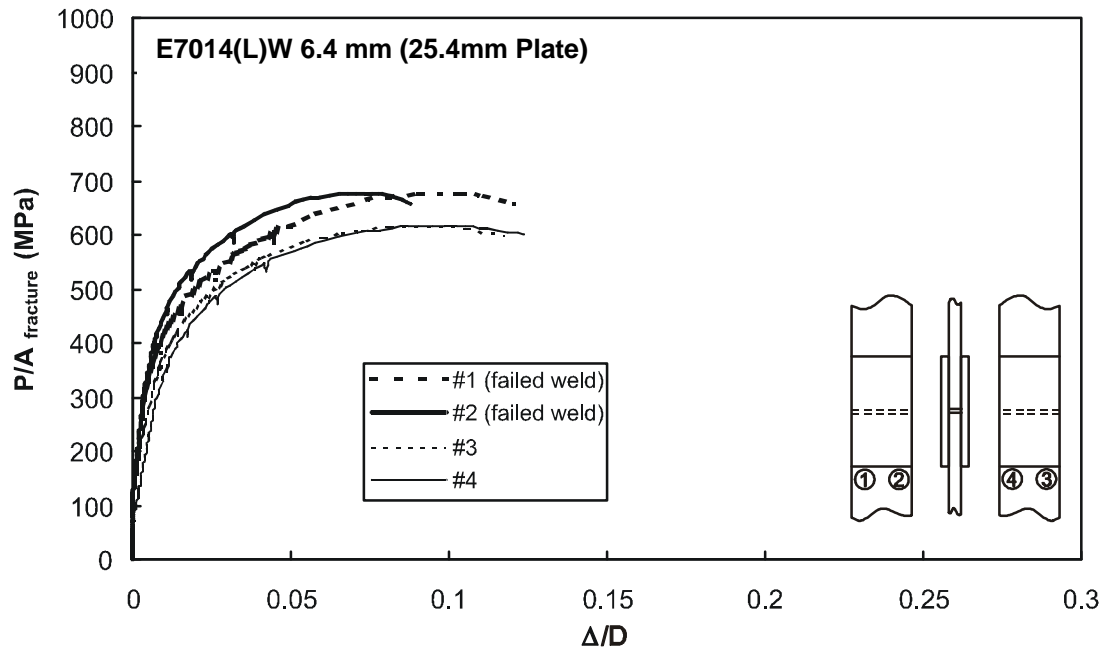

Figure F3 – Specimen T1-3 with 6.4 mm weld from E7014 electrode

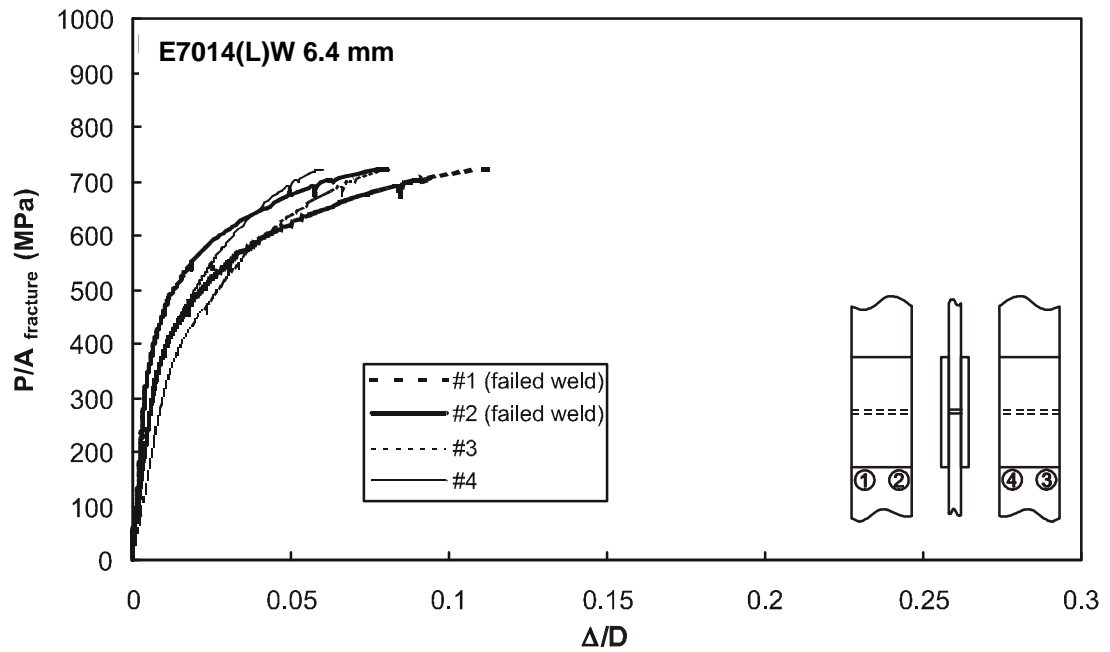

Figure F4 – Specimen T2-1 with 6.4 mm weld from E7014 electrode

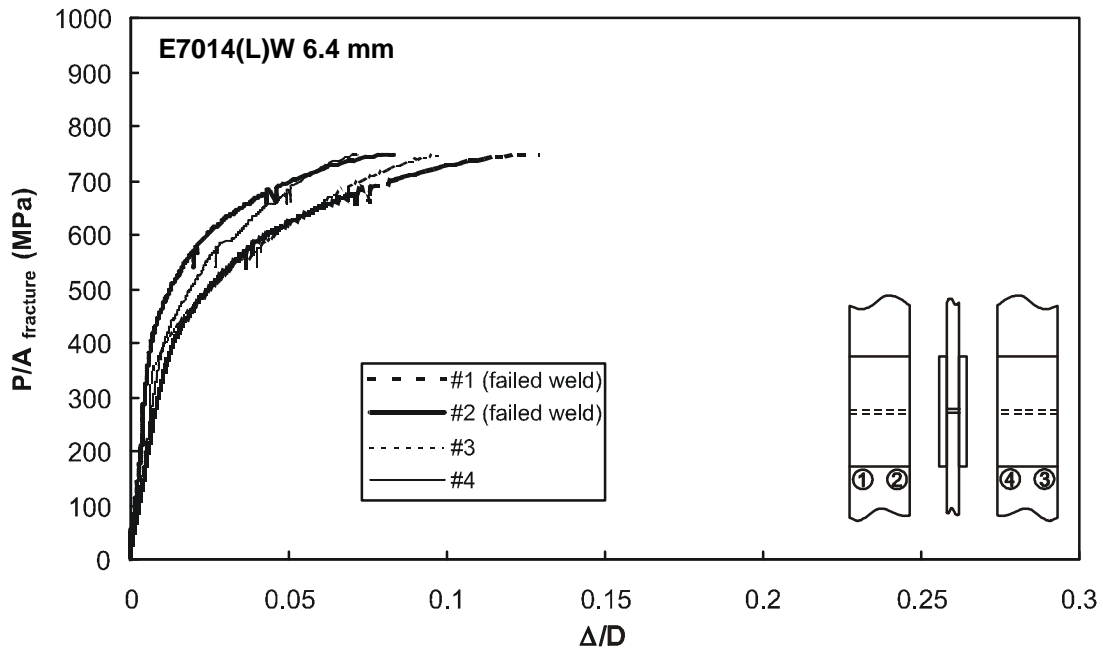

Figure F5 – Specimen T2-2 with 6.4 mm weld from E7014 electrode

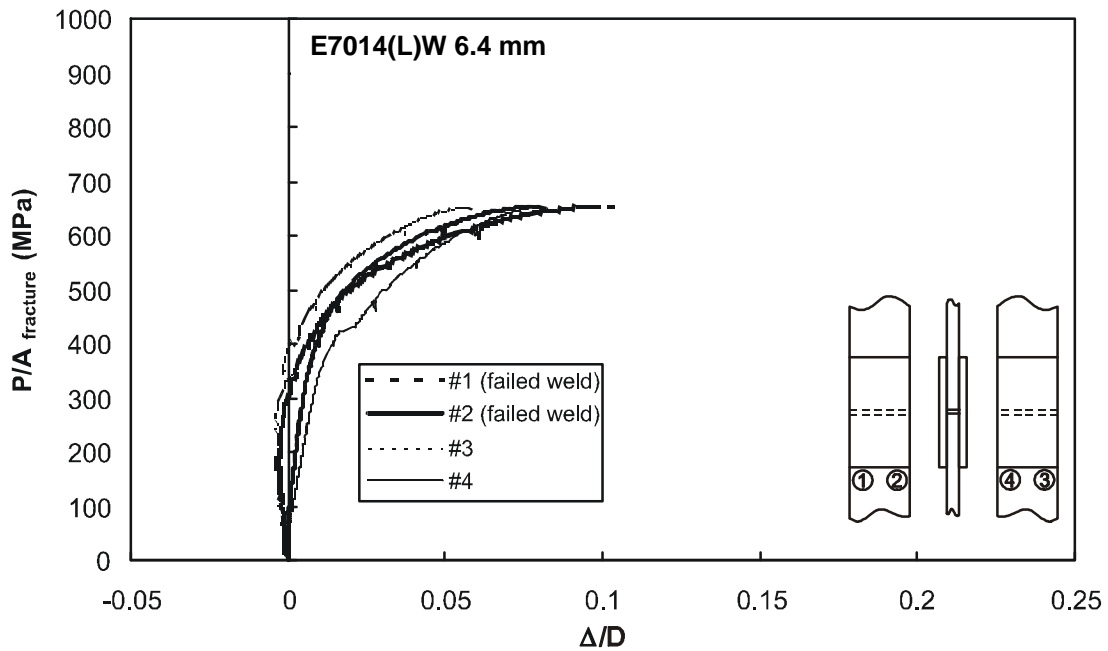

Figure F6 – Specimen T2-3 with 6.4 mm weld from E7014 electrode

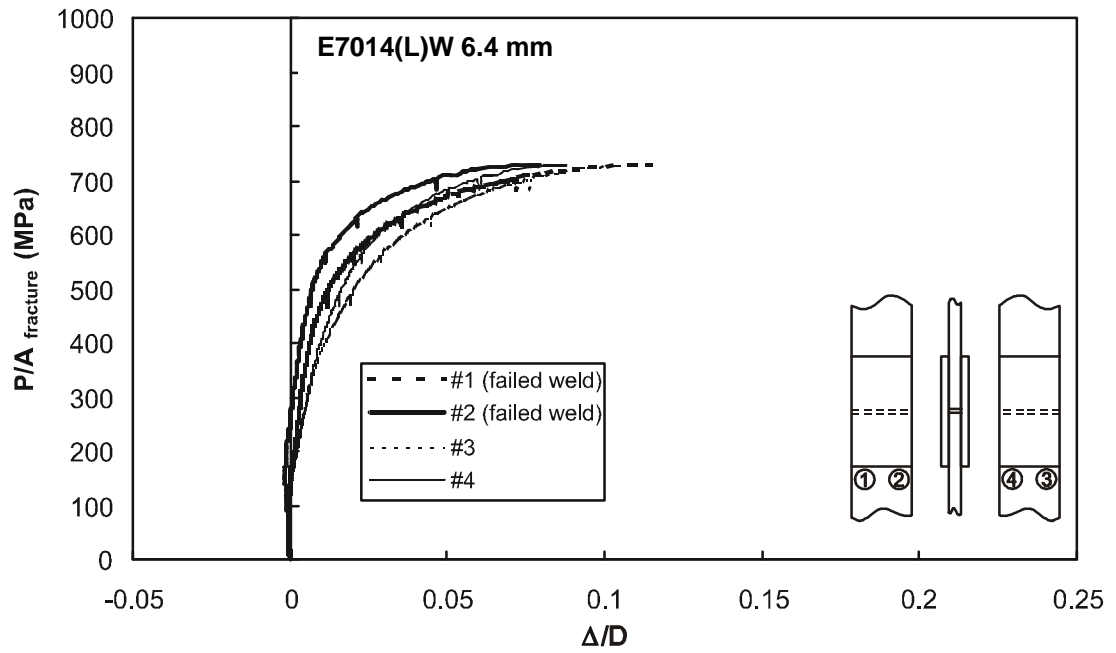

Figure F7 – Specimen T3-1 with 6.4 mm weld from E7014 electrode

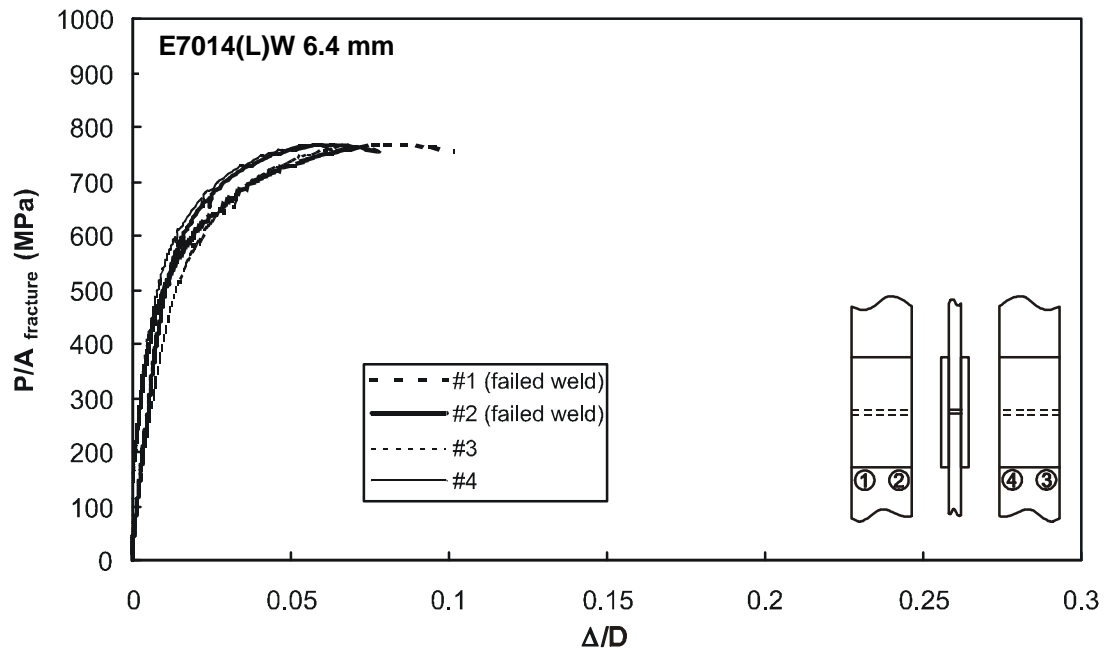

Figure F8 – Specimen T3-2 with 6.4 mm weld from E7014 electrode

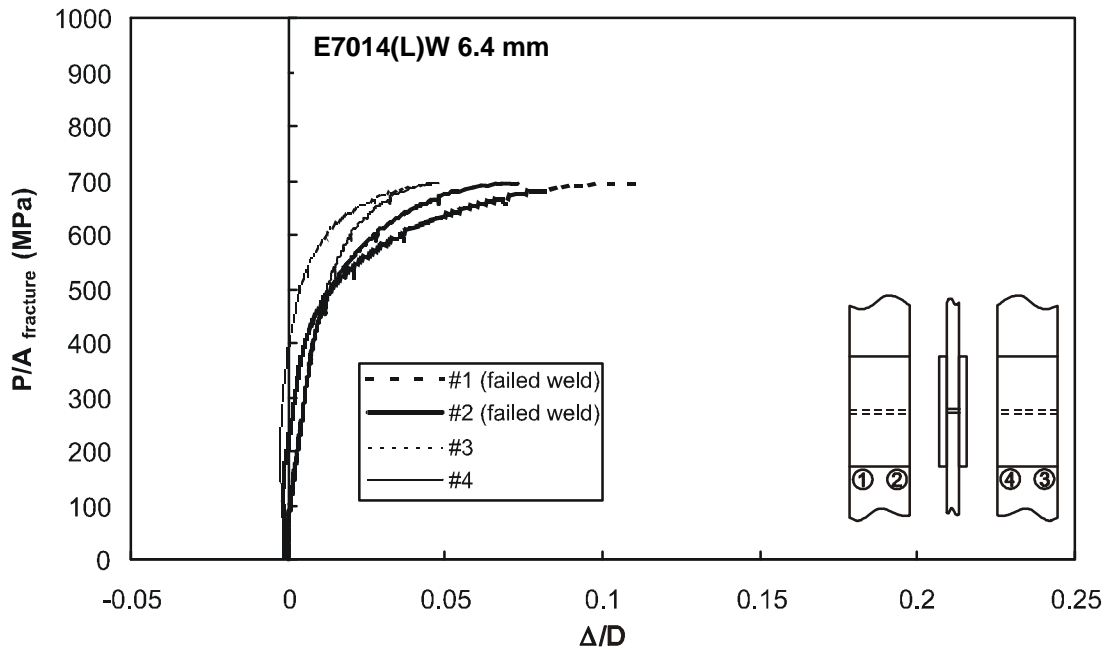

Figure F9 – Specimen T3-3 with 6.4 mm weld from E7014 electrode

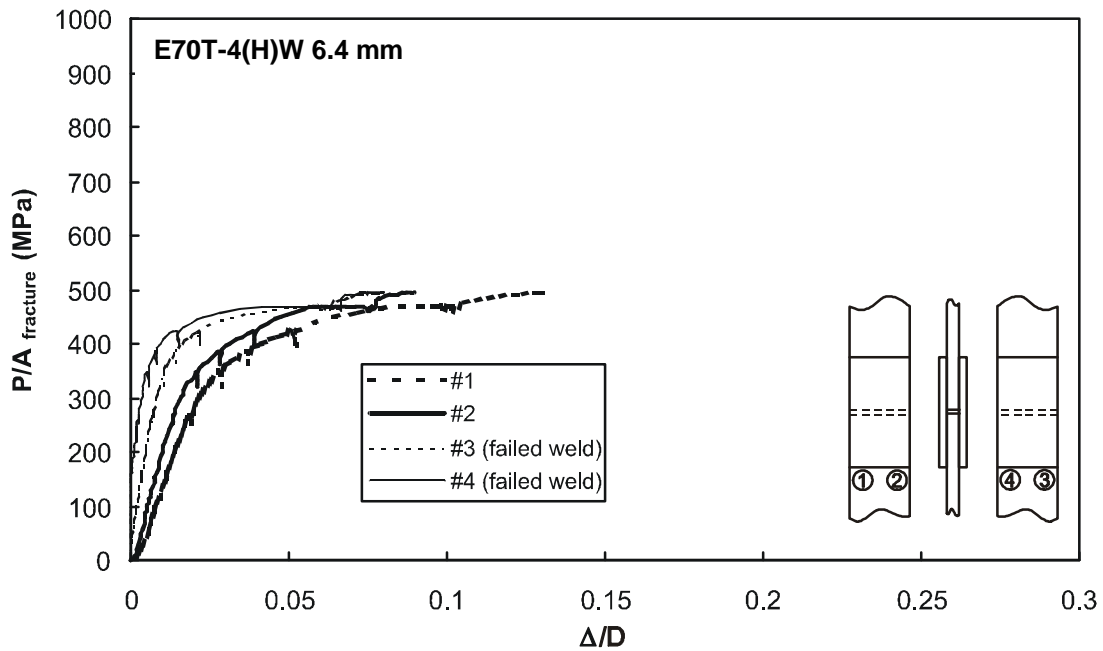

Figure F10 – Specimen T4-1 with 6.4 mm weld from E70T-4 electrode

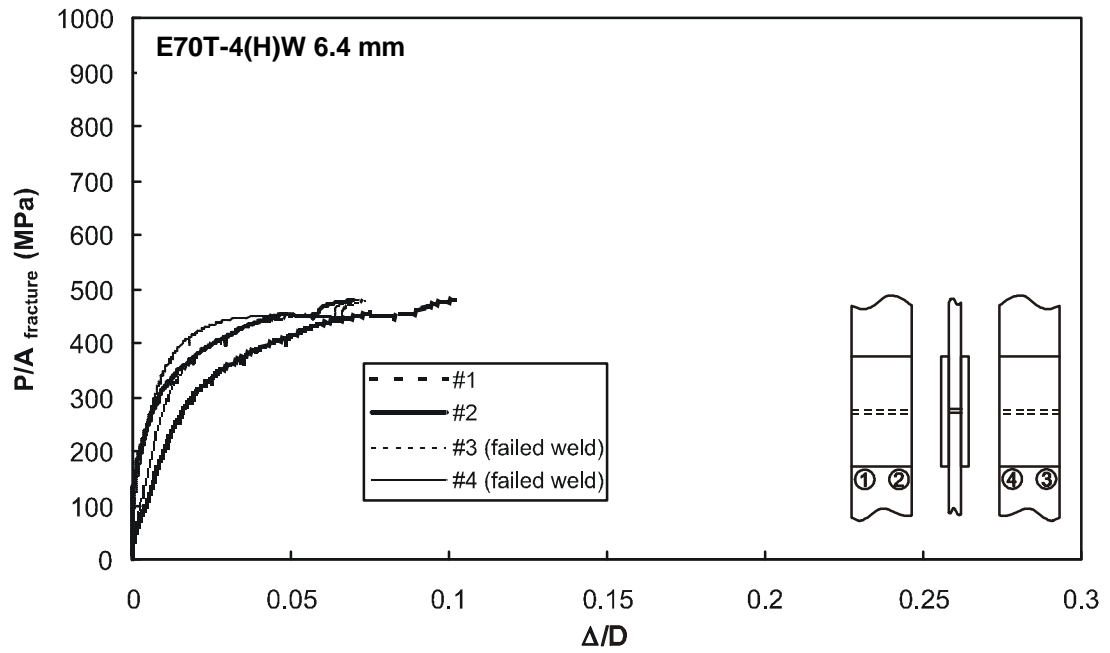

Figure F11 – Specimen T4-2 with 6.4 mm weld from E70T-4 electrode

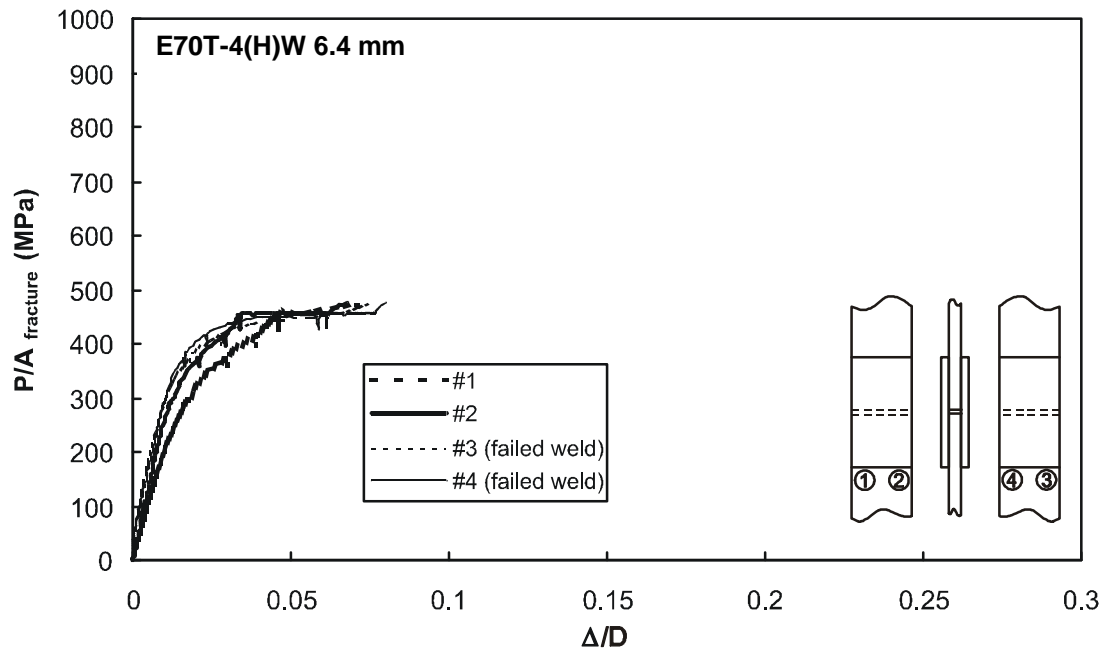

Figure F12 – Specimen T4-3 with 6.4 mm weld from E70T-4 electrode

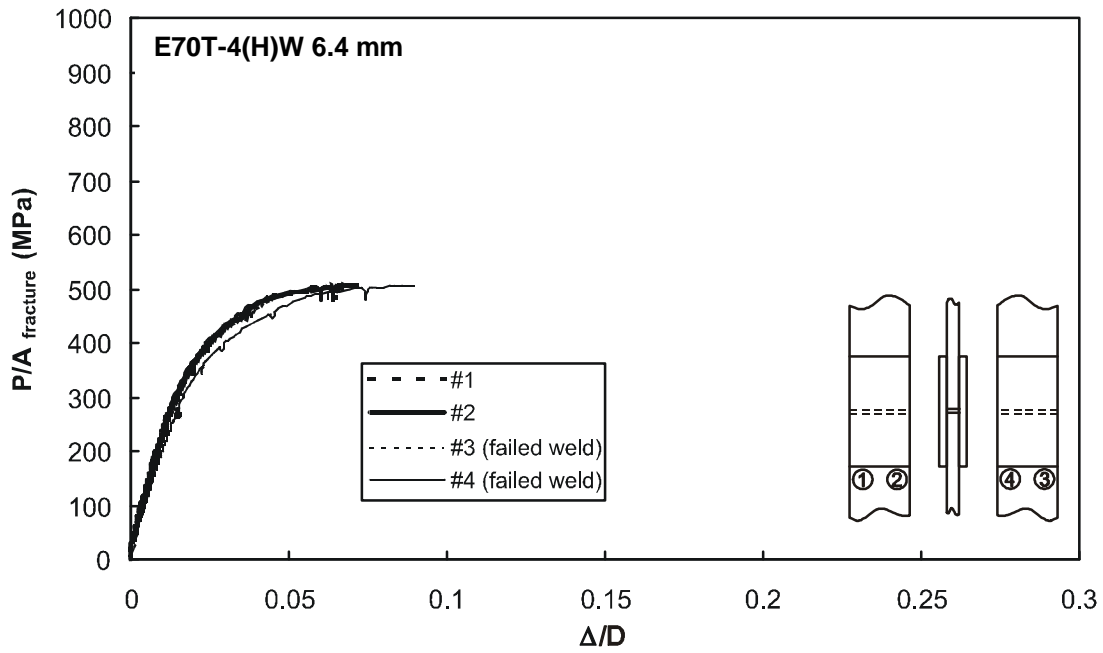

Figure F13 – Specimen T5-1 with 6.4 mm weld from E70T-4 electrode

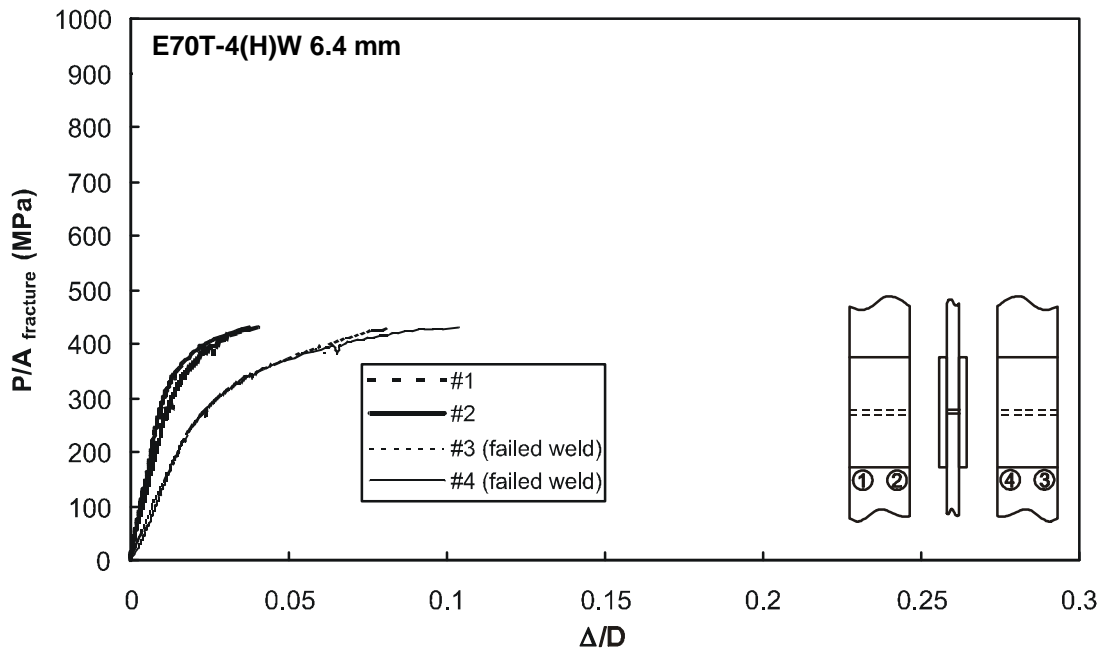

Figure F14 – Specimen T5-2 with 6.4 mm weld from E70T-4 electrode

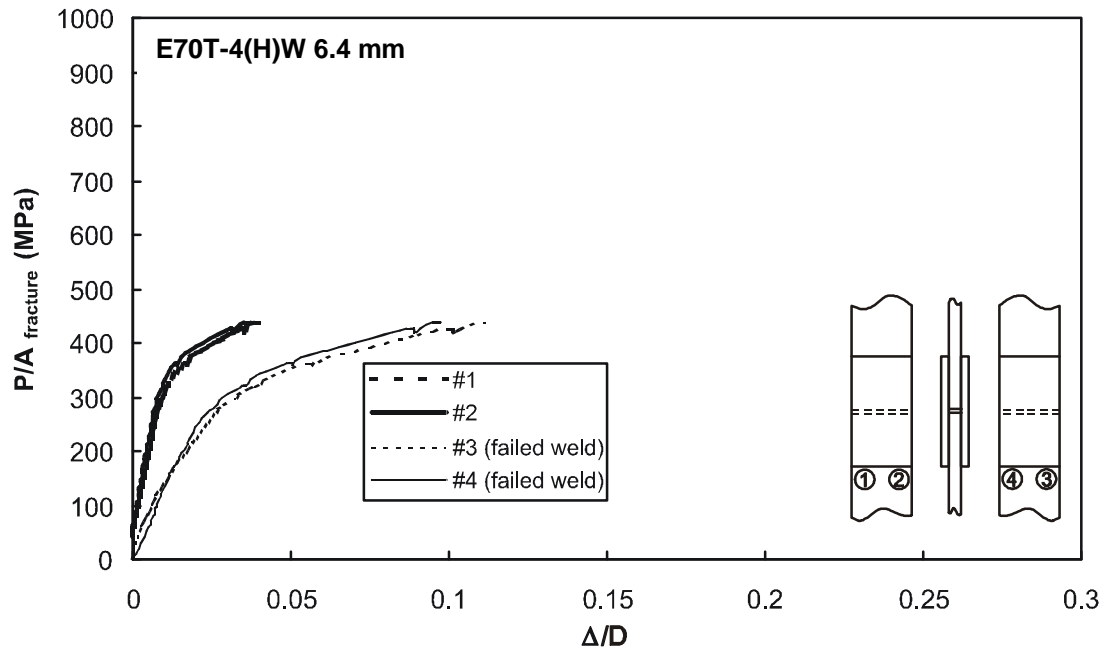

Figure F15 – Specimen T5-3 with 6.4 mm weld from E70T-4 electrode

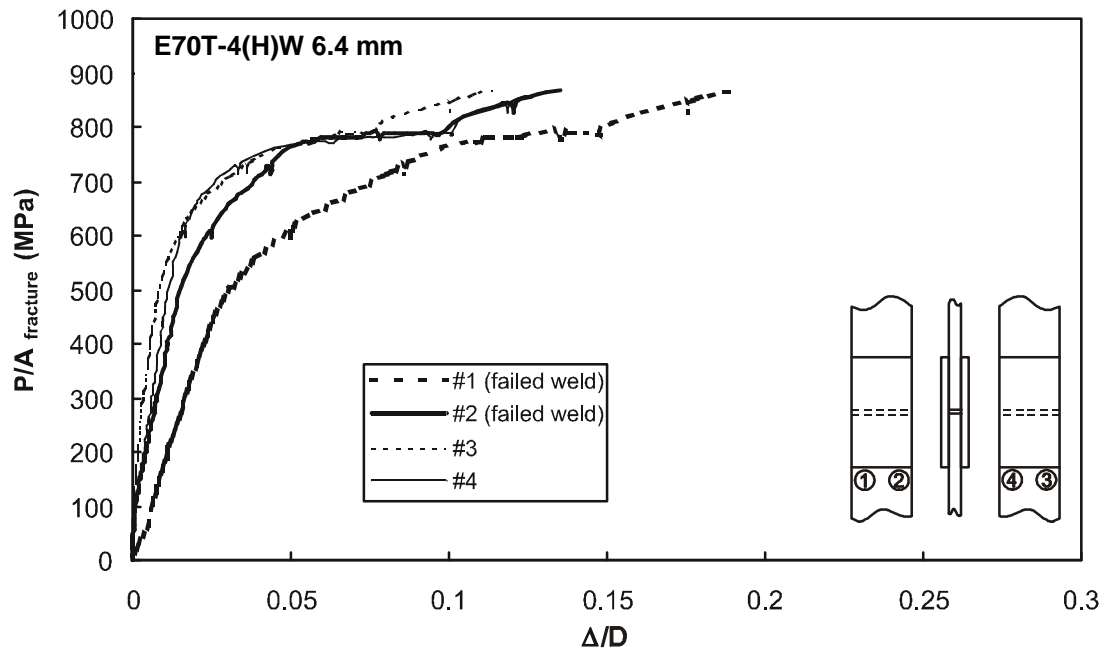

Figure F16 – Specimen T6-1 with 6.4 mm weld from E70T-4 electrode

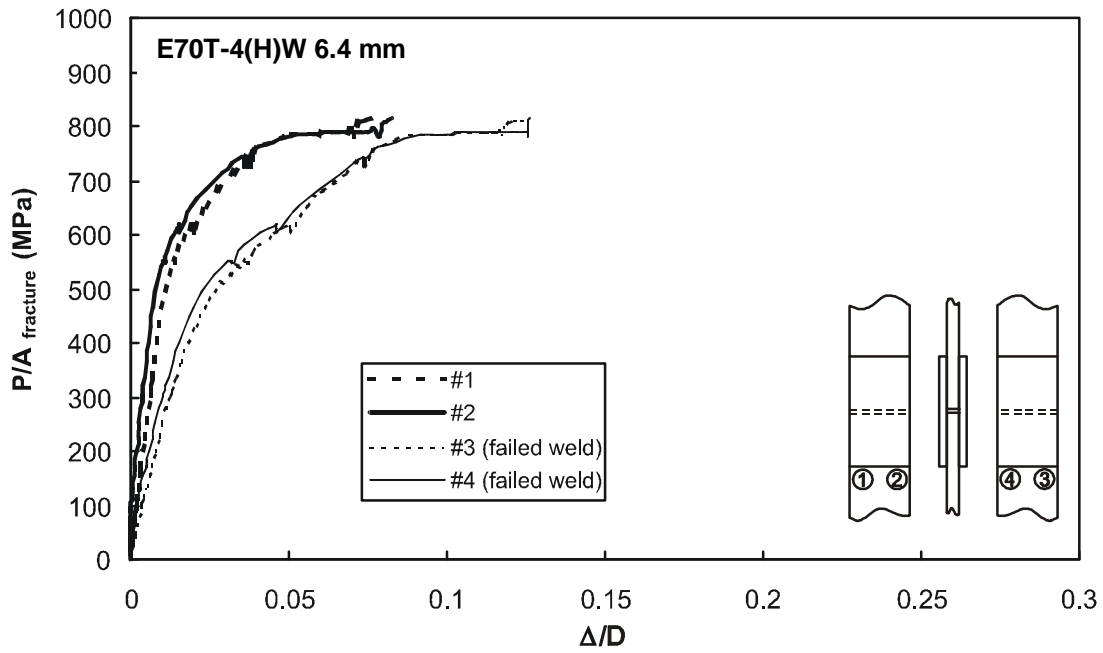

Figure F17 – Specimen T6-2 with 6.4 mm weld from E70T-4 electrode

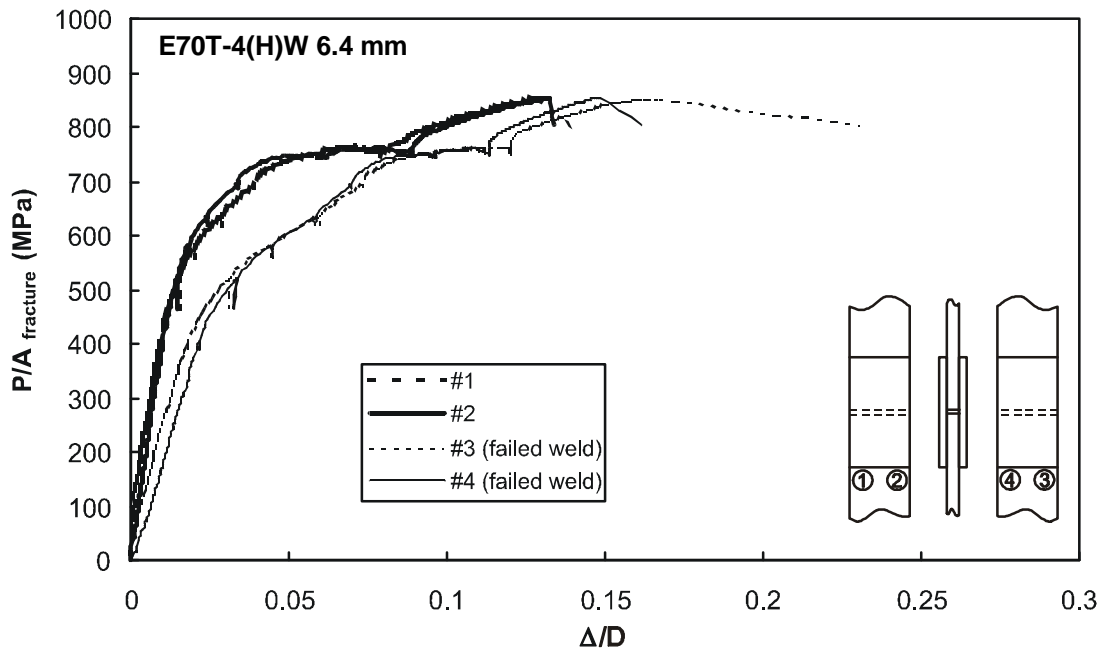

Figure F18 – Specimen T6-3 with 6.4 mm weld from E70T-4 electrode

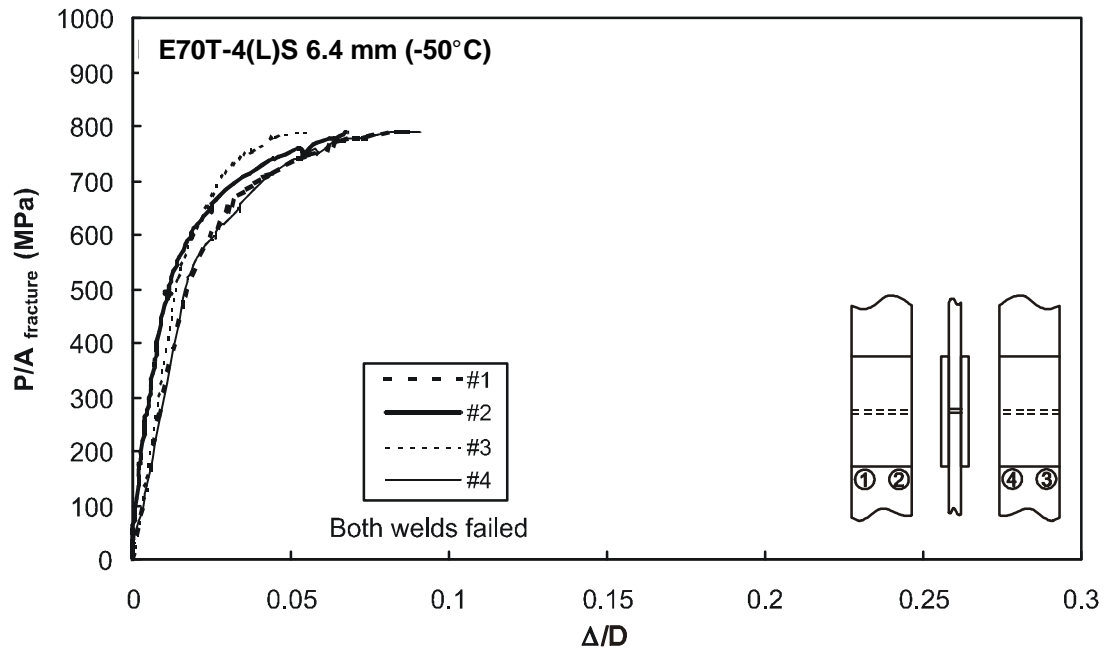

Figure F19 – Specimen T7-1 with 6.4 mm weld from E70T-4 electrode

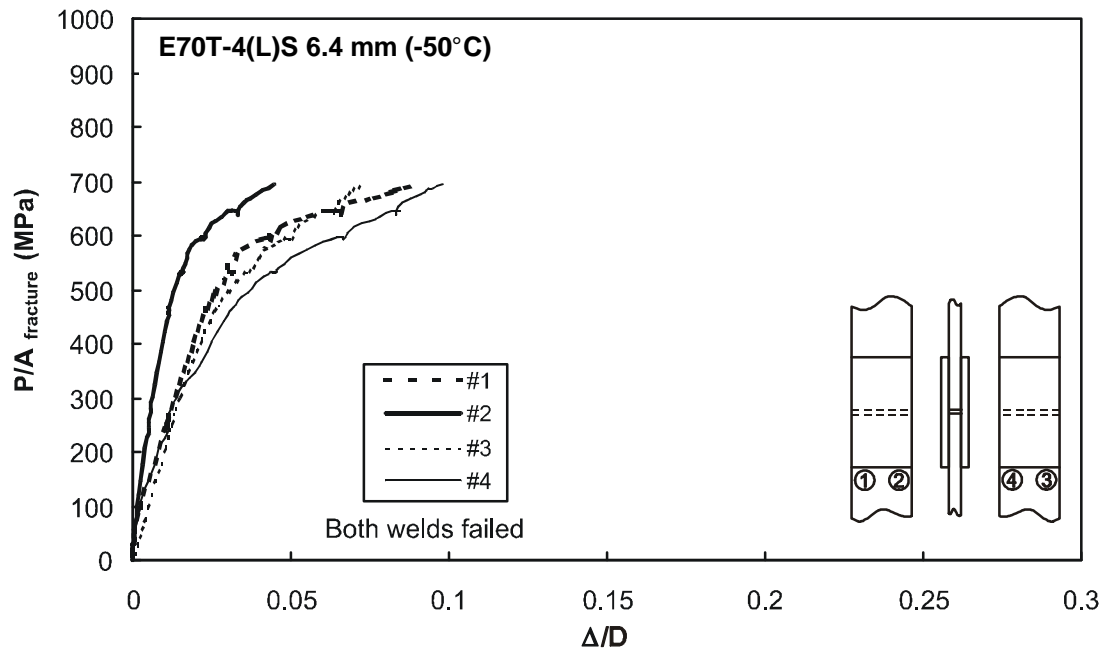

Figure F20 – Specimen T7-2 with 6.4 mm weld from E70T-4 electrode

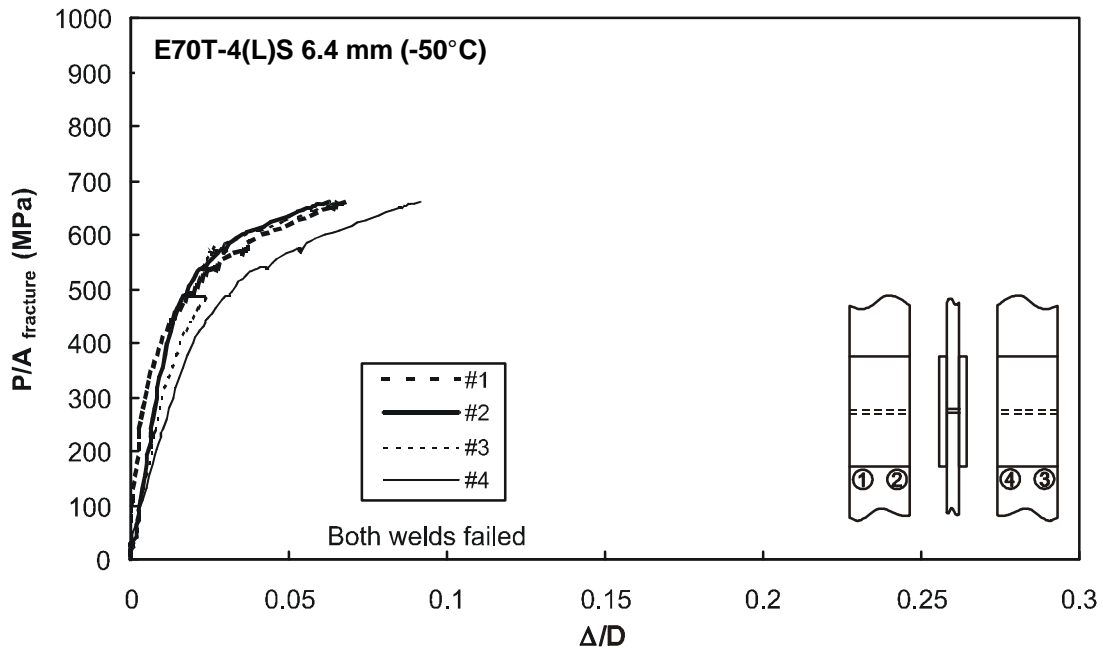

Figure F21 – Specimen T7-3 with 6.4 mm weld from E70T-4 electrode

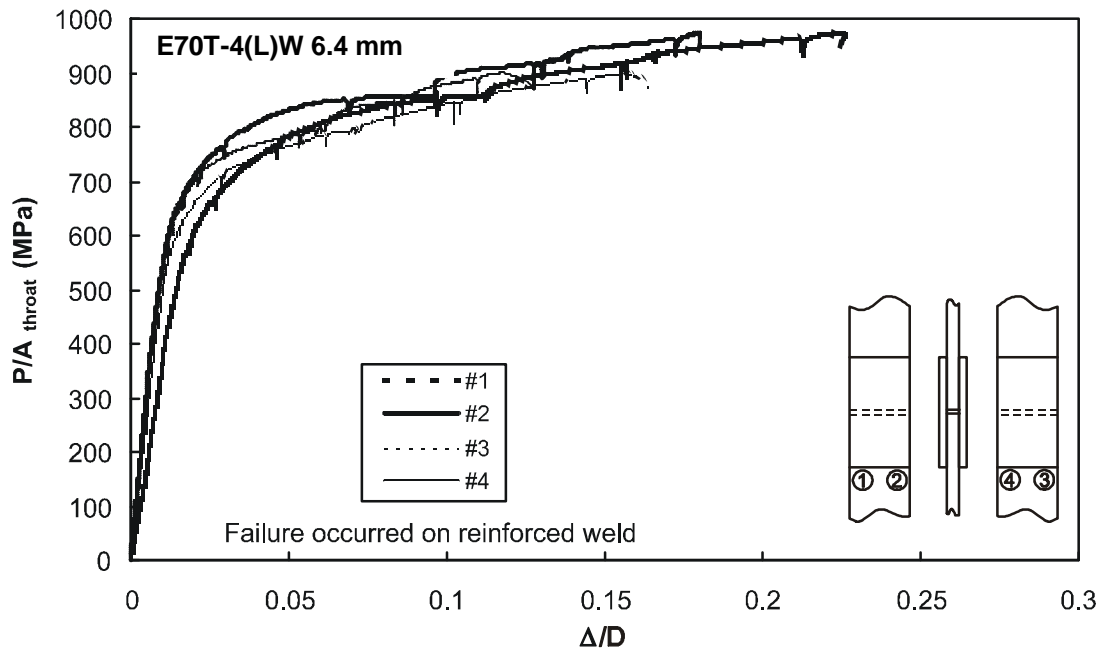

Figure F22 – Specimen T8-1 with 6.4 mm weld from E70T-4 electrode

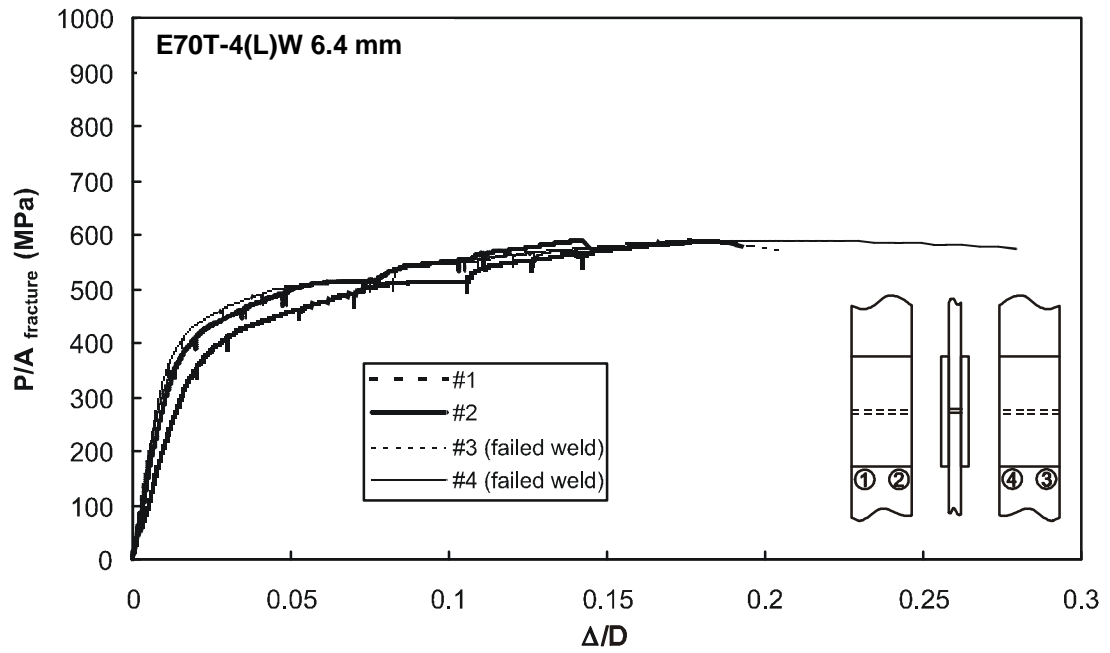

Figure F23 – Specimen T8-2 with 6.4 mm weld from E70T-4 electrode

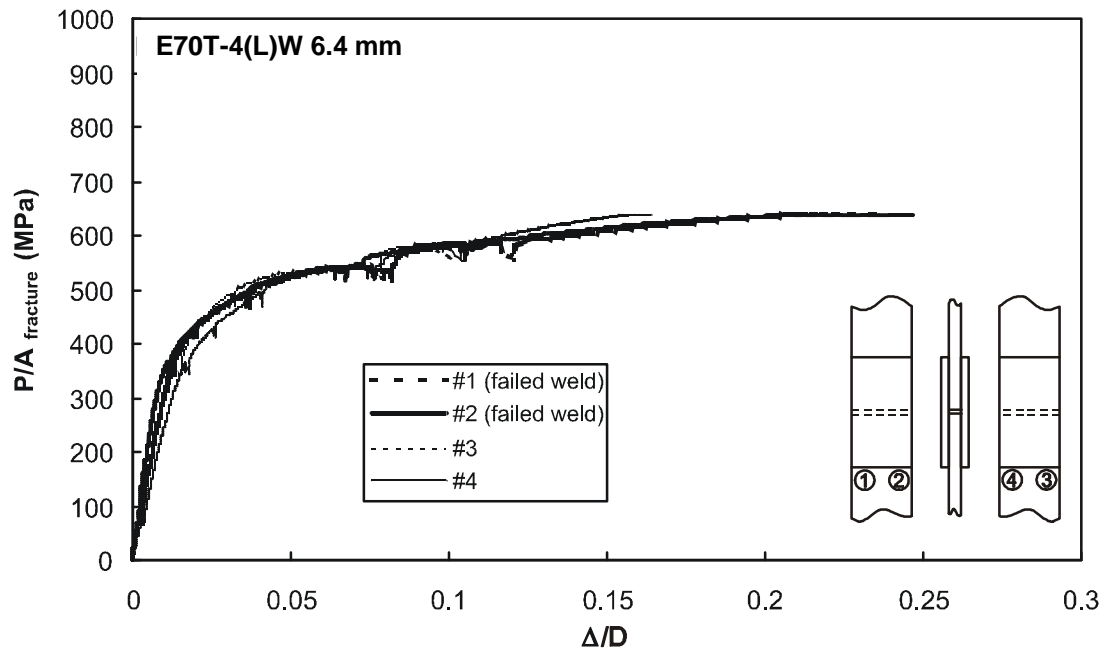

Figure F24 – Specimen T8-3 with 6.4 mm weld from E70T-4 electrode

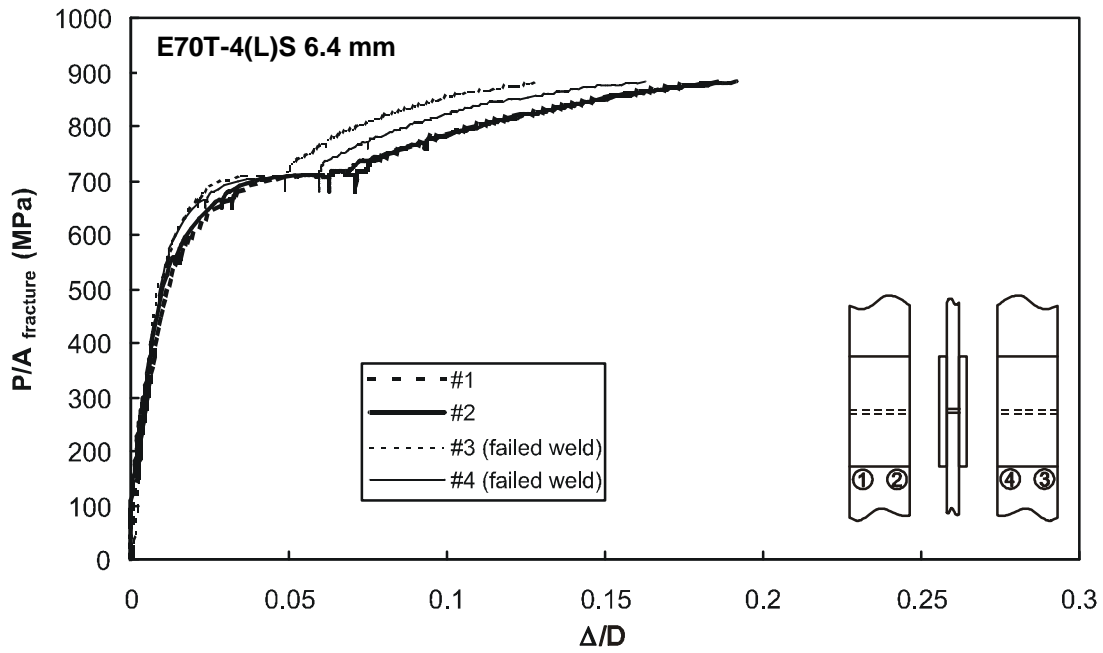

Figure F25 – Specimen T9-1 with 6.4 mm weld from E70T-4 electrode

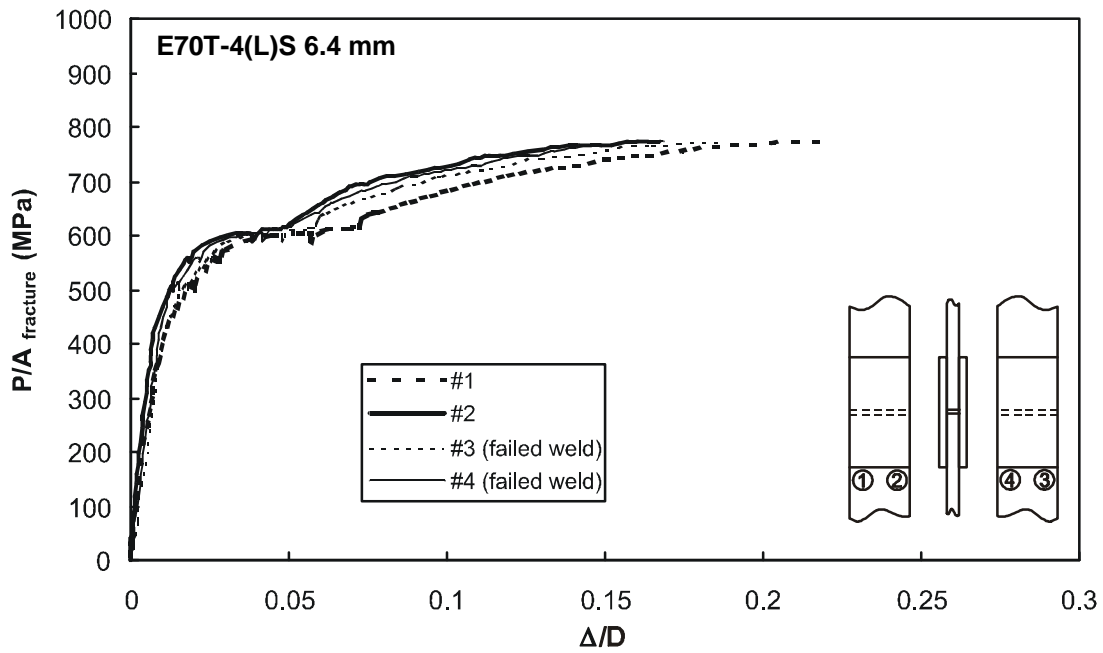

Figure F26 – Specimen T9-2 with 6.4 mm weld from E70T-4 electrode

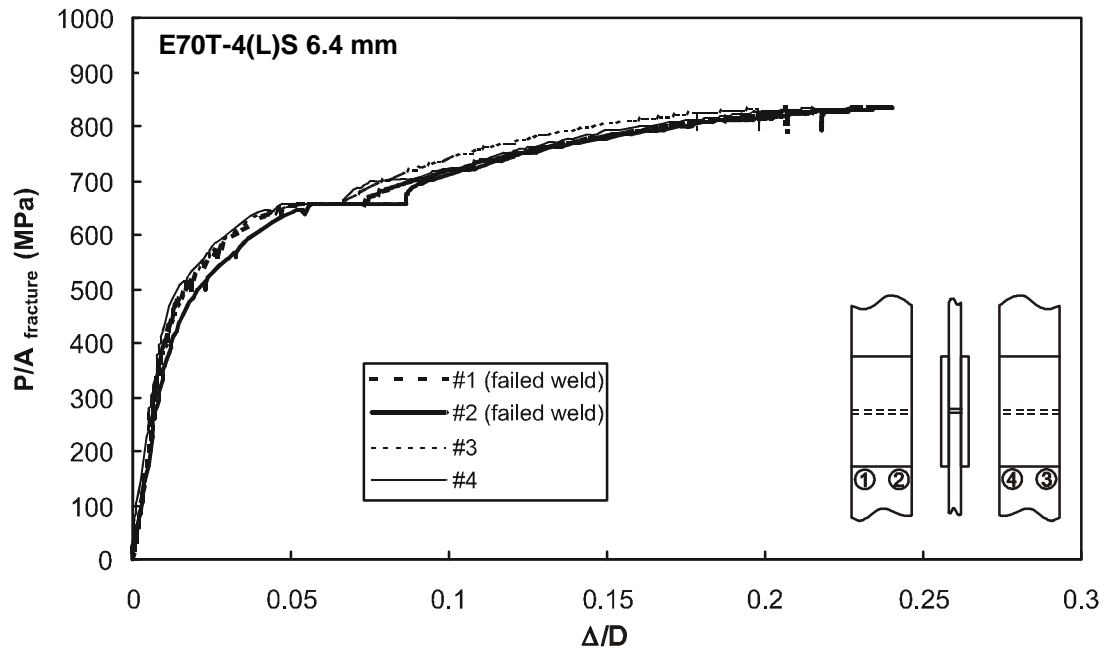

Figure F27 – Specimen T9-3 with 6.4 mm weld from E70T-4 electrode

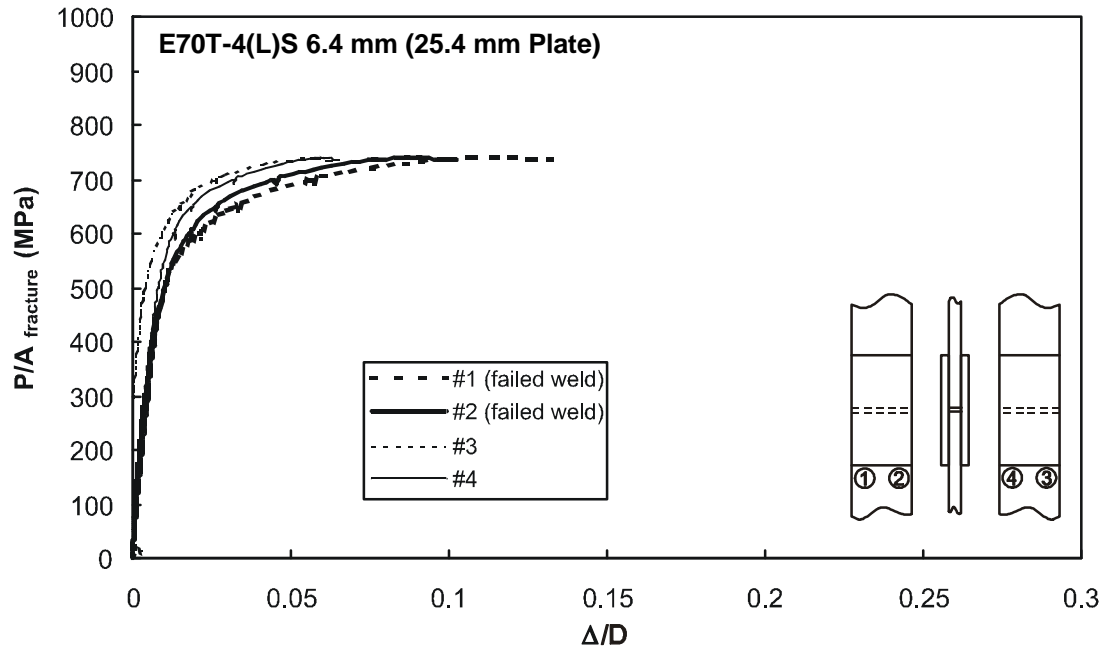

Figure F28 – Specimen T10-1 with 6.4 mm weld from E70T-4 electrode

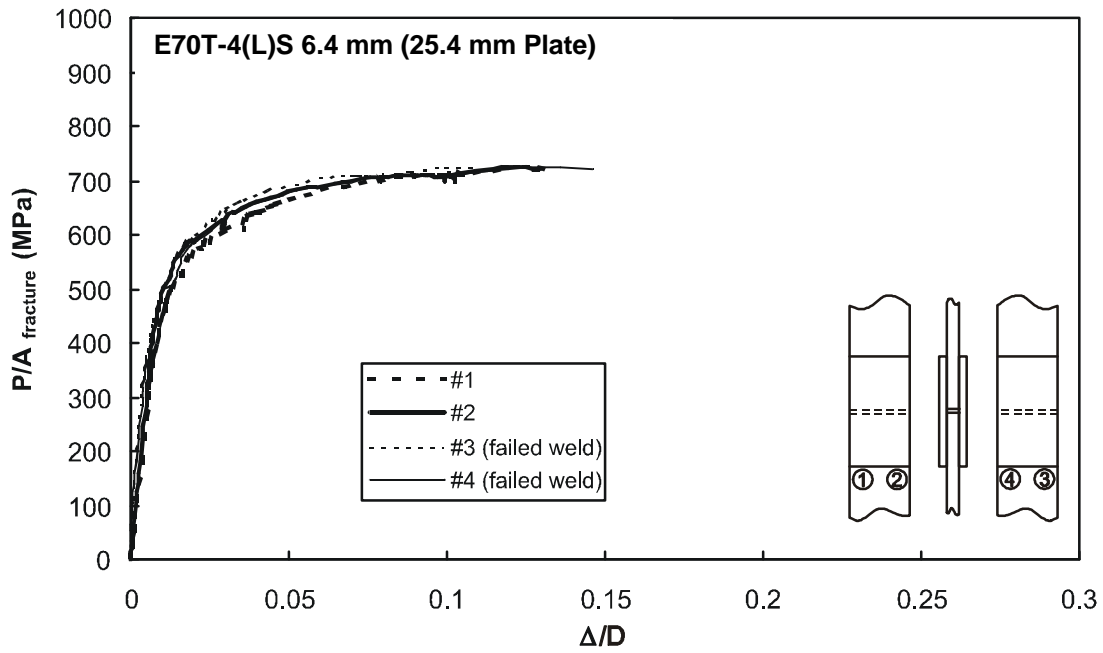

Figure F29 – Specimen T10-2 with 6.4 mm weld from E70T-4 electrode

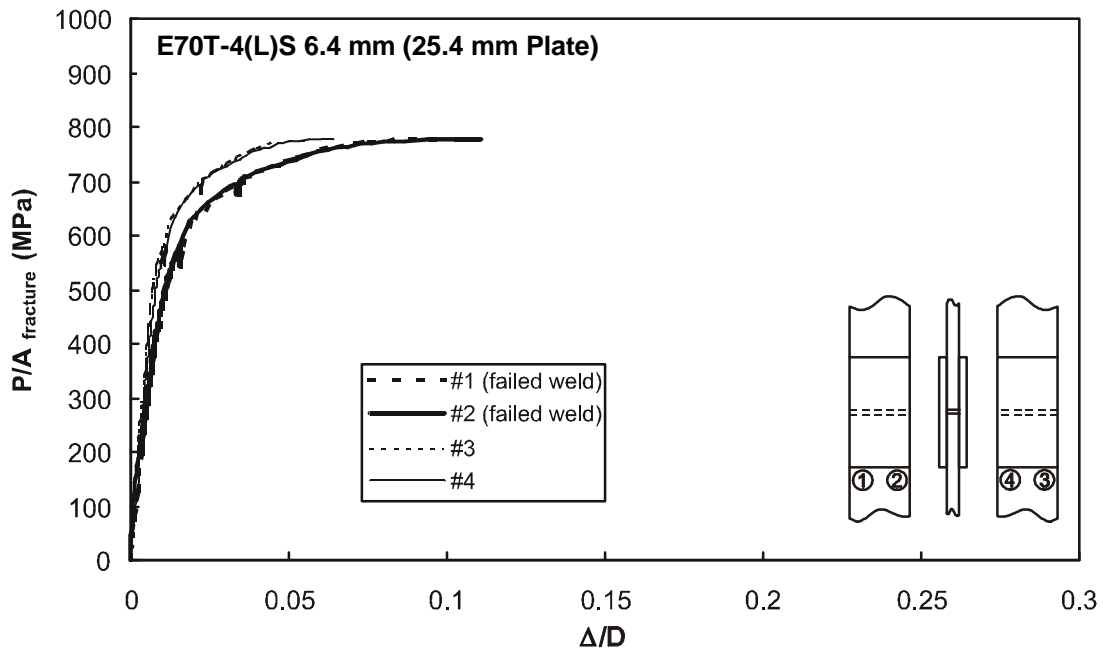

Figure F30 – Specimen T10-3 with 6.4 mm weld from E70T-4 electrode

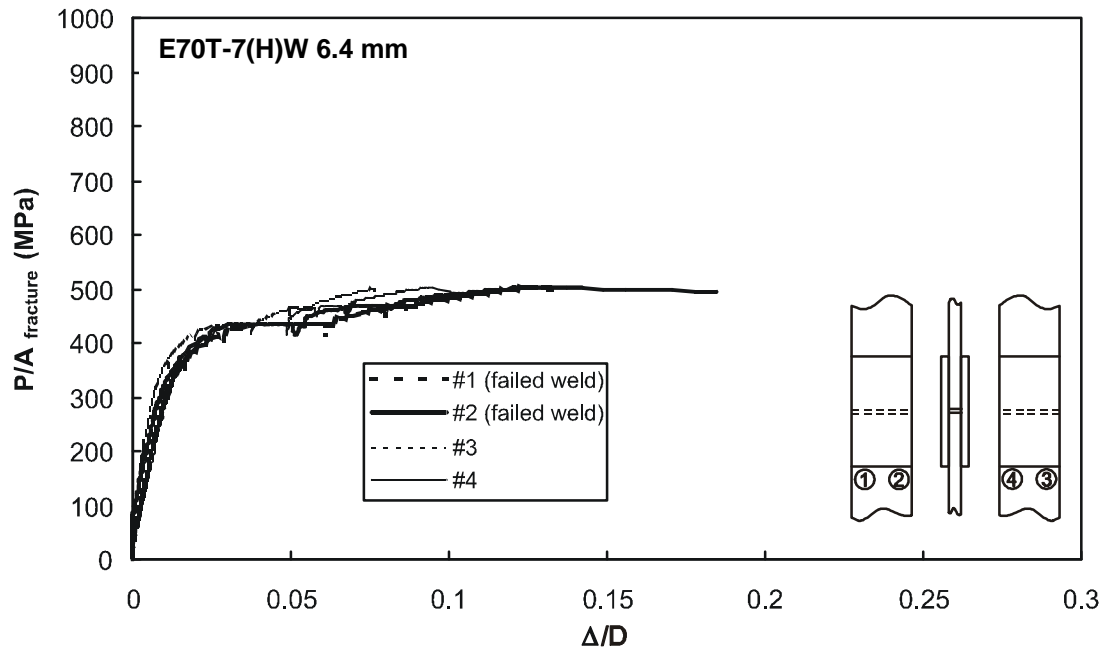

Figure F31 – Specimen T11-1 with 6.4 mm weld from E70T-7 electrode

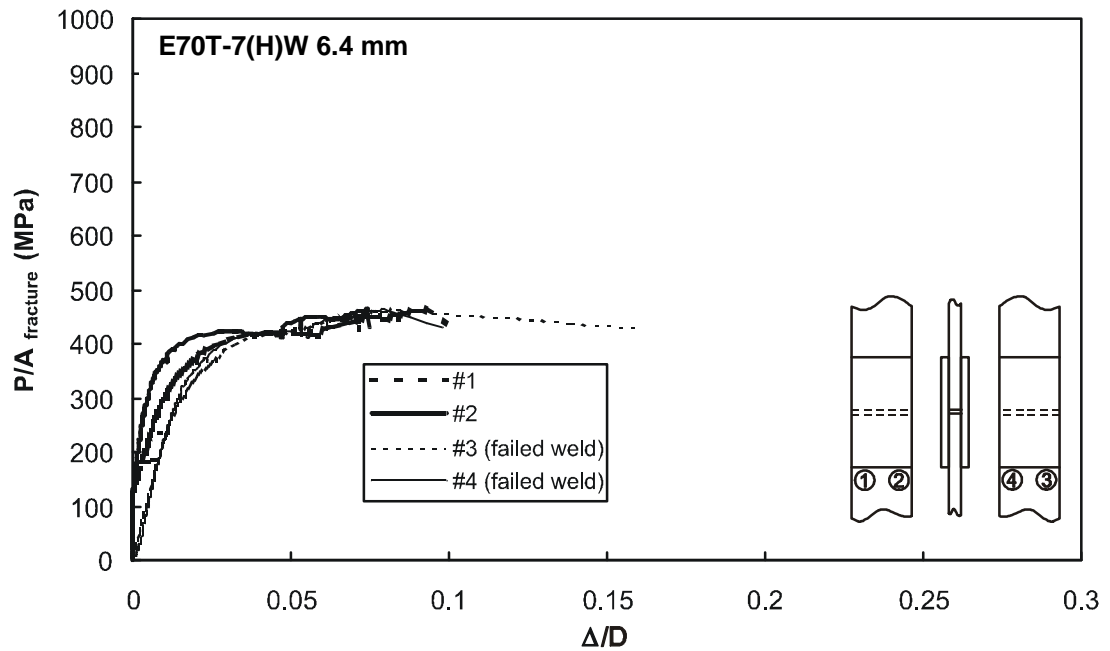

Figure F32 – Specimen T11-2 with 6.4 mm weld from E70T-7 electrode

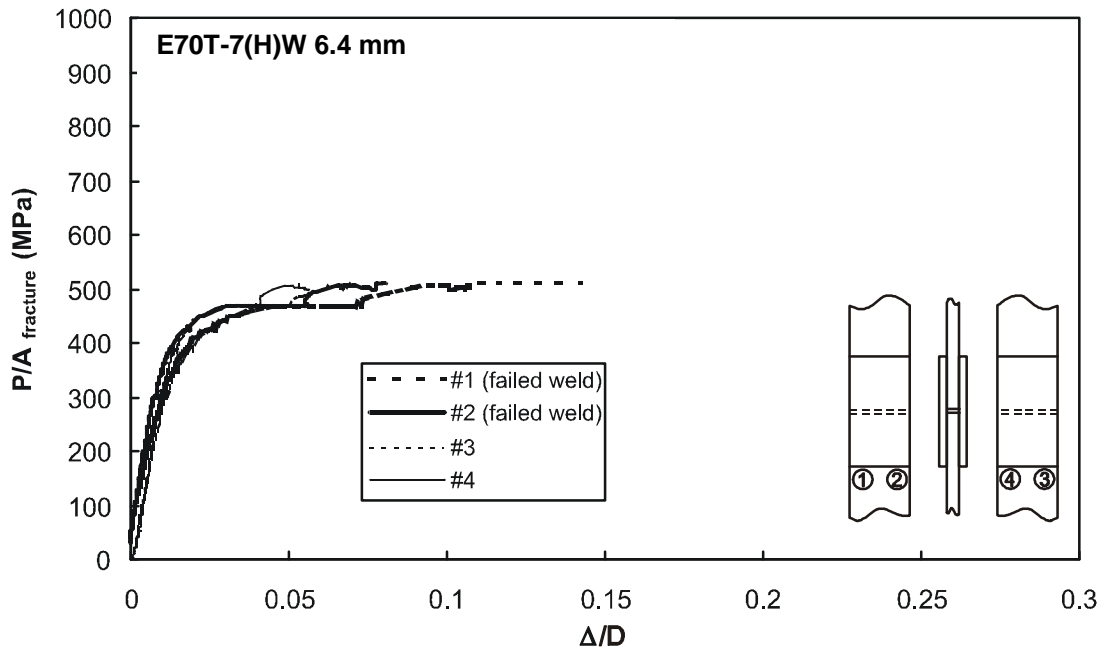

Figure F33 – Specimen T11-3 with 6.4 mm weld from E70T-7 electrode

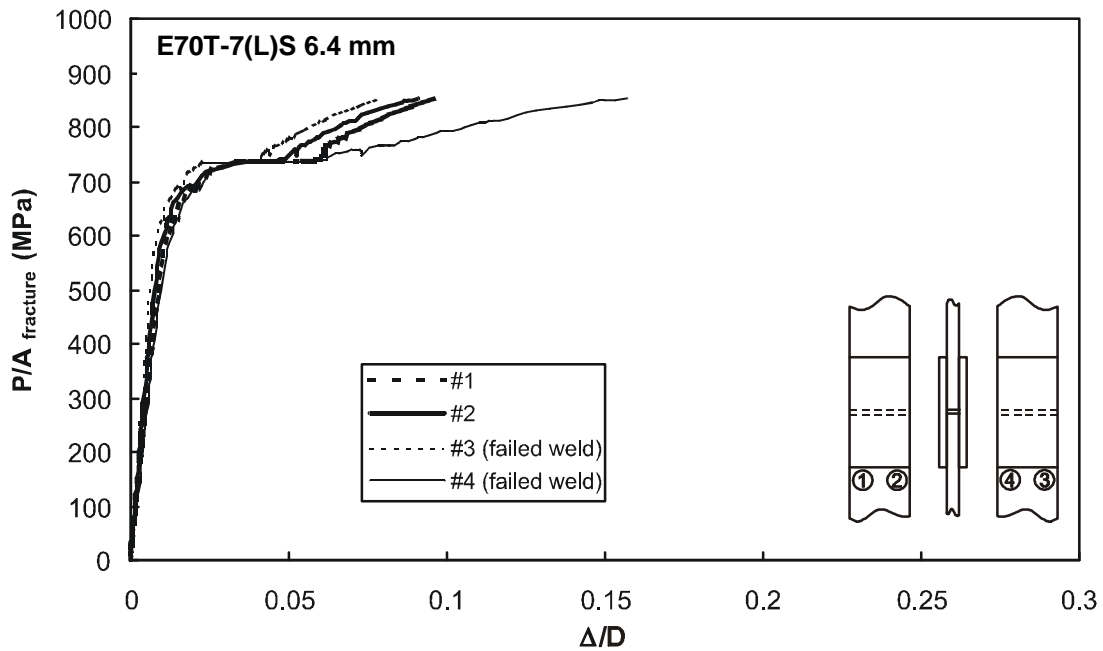

Figure F34 – Specimen T12-1 with 6.4 mm weld from E70T-7 electrode

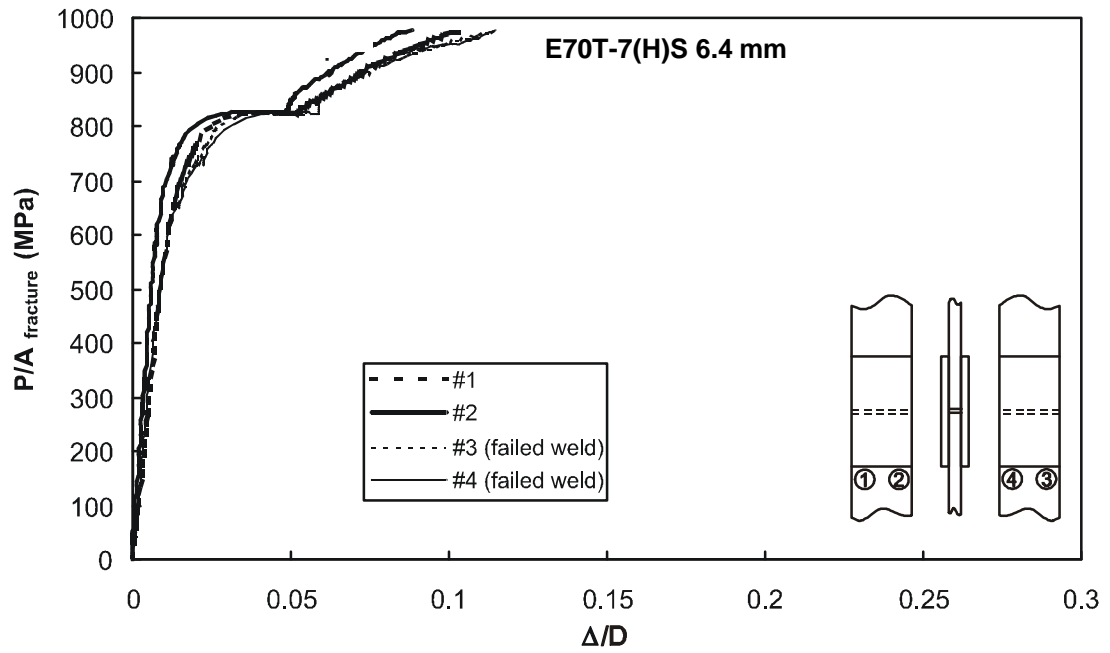

Figure F35 – Specimen T12-2 with 6.4 mm weld from E70T-7 electrode

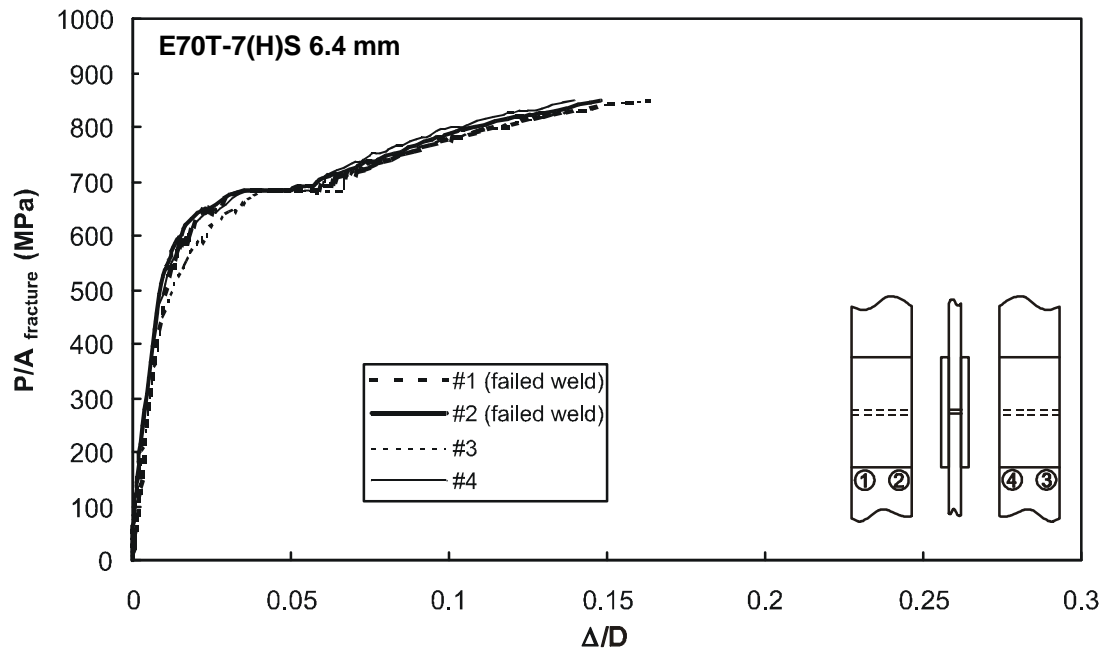

Figure F36 – Specimen T12-3 with 6.4 mm weld from E70T-7 electrode

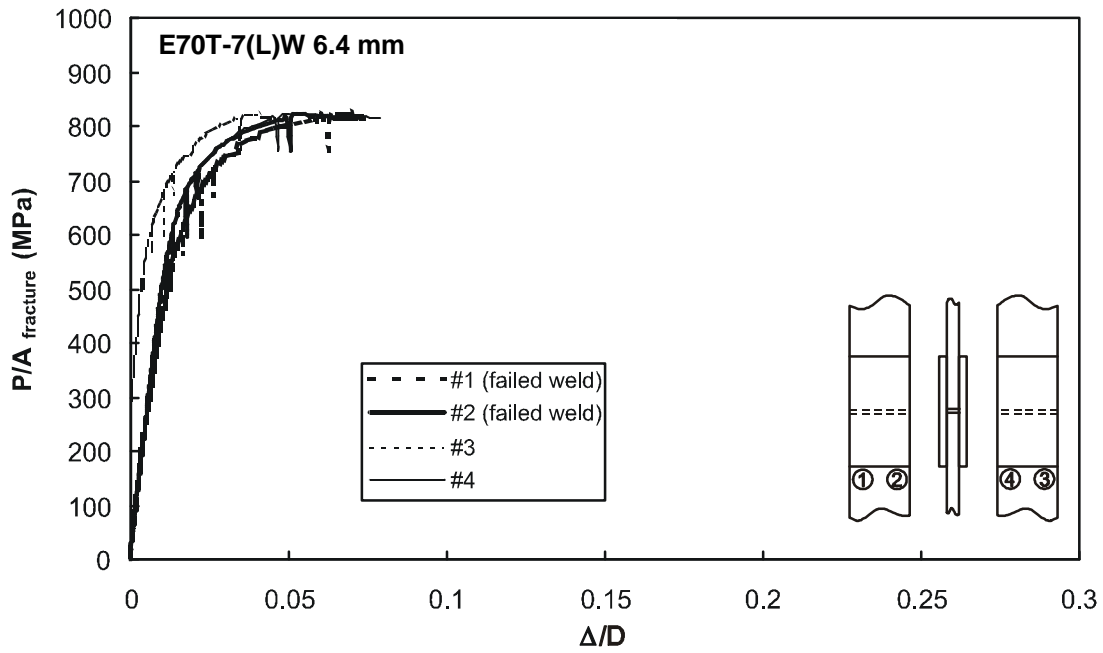

Figure F37 – Specimen 13-1 with 6.4 mm weld from E70T-7 electrode

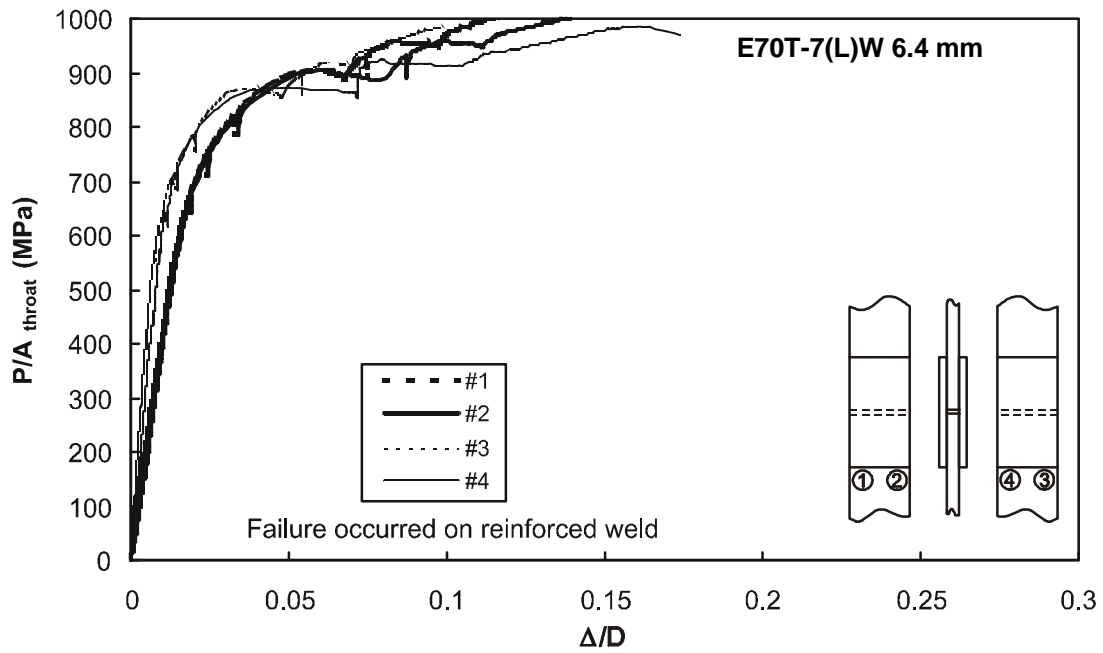

Figure F38 – Specimen 13-2 with 6.4 mm weld from E70T-7 electrode

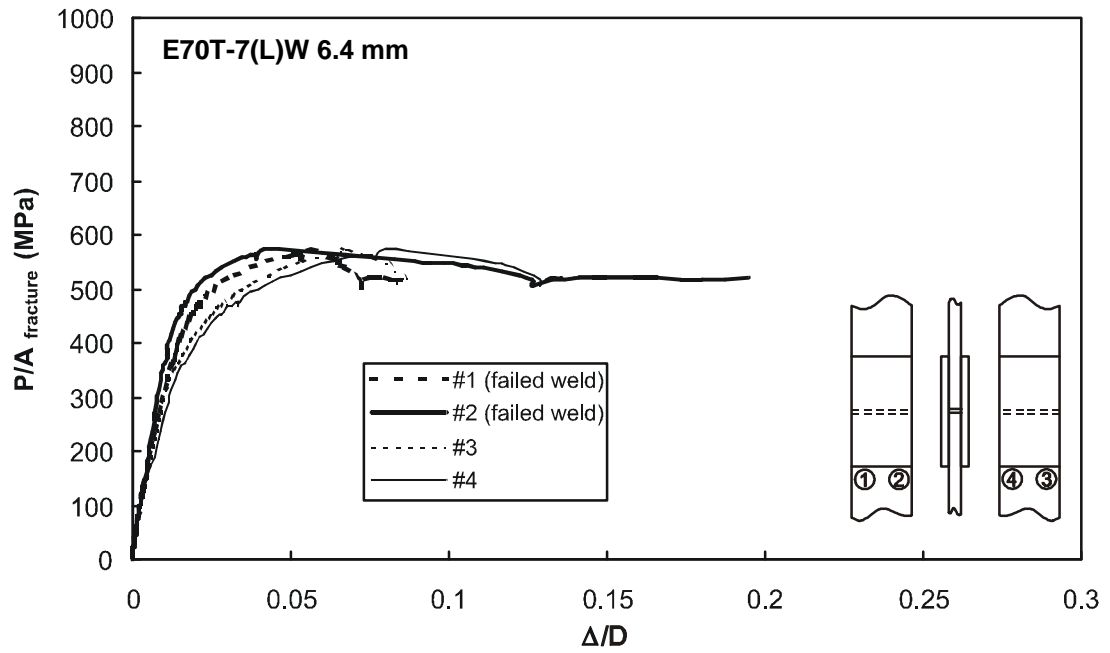

Figure F39 – Specimen T13-3 with 6.4 mm weld from E70T-7 electrode

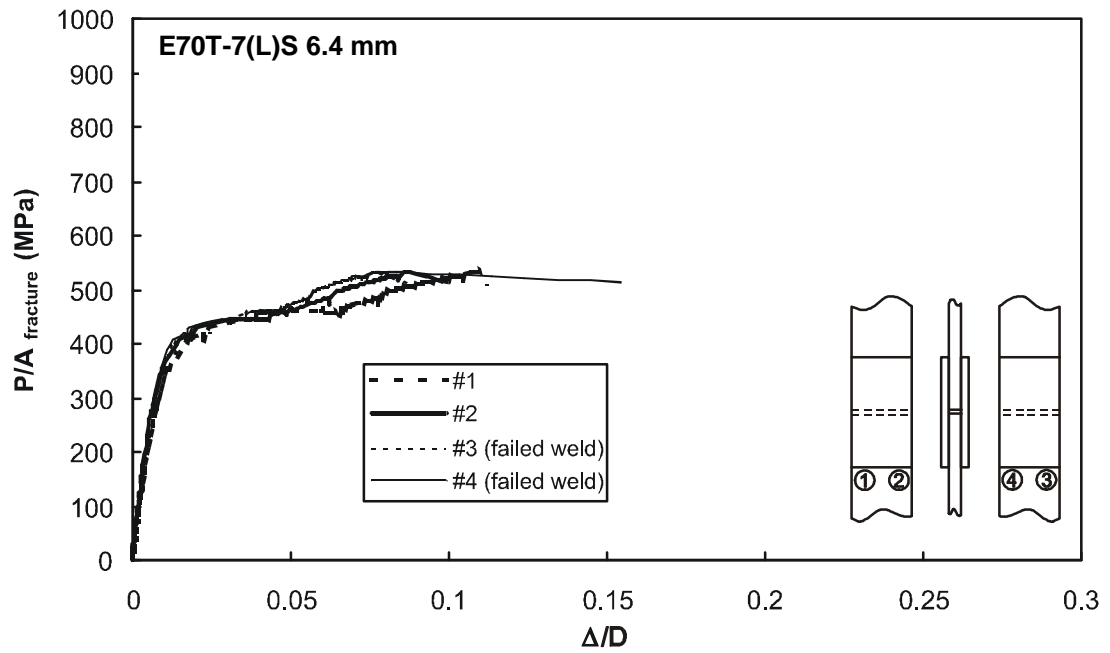

Figure F40 – Specimen T14-1 with 6.4 mm weld from E70T-7 electrode

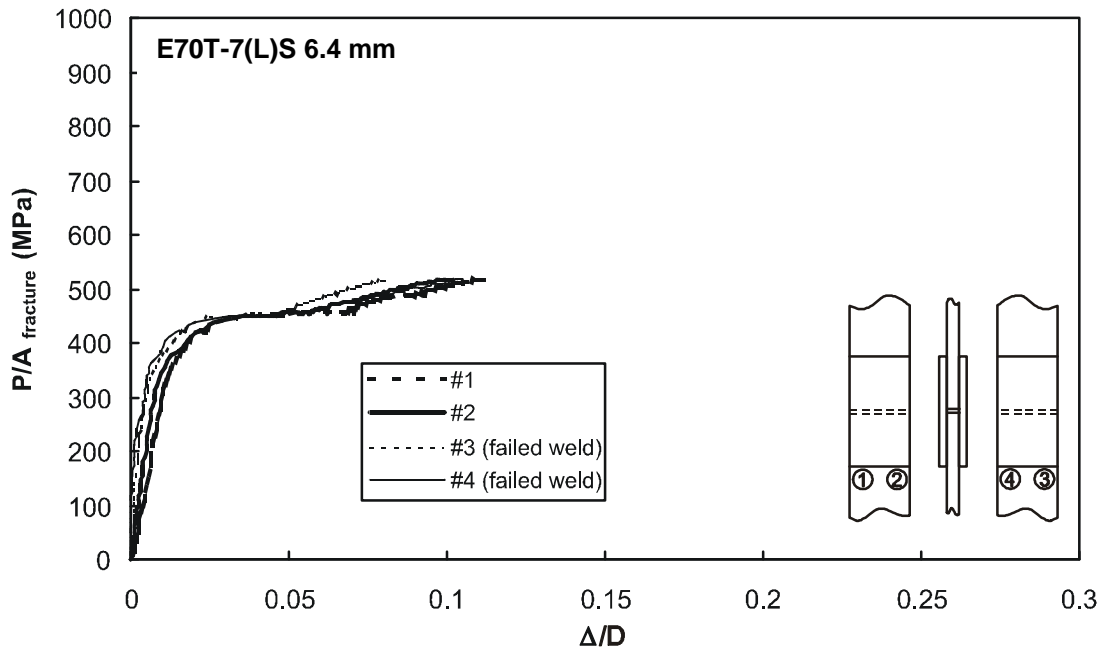

Figure F41 – Specimen T14-2 with 6.4 mm weld from E70T-7 electrode

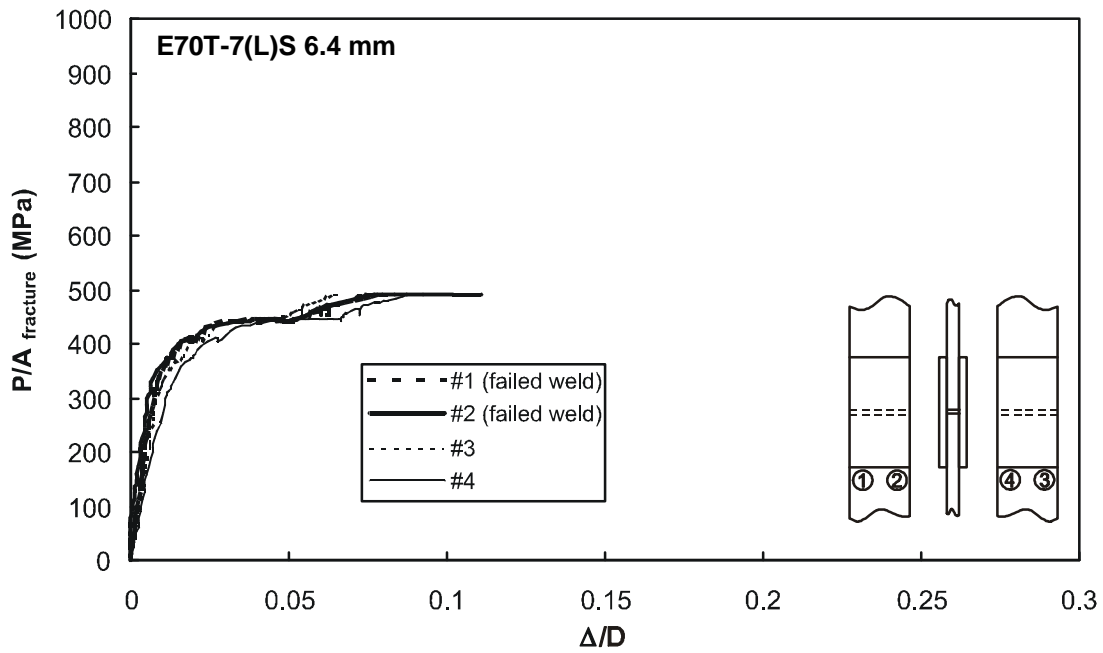

Figure F42 – Specimen T14-3 with 6.4 mm weld from E70T-7 electrode

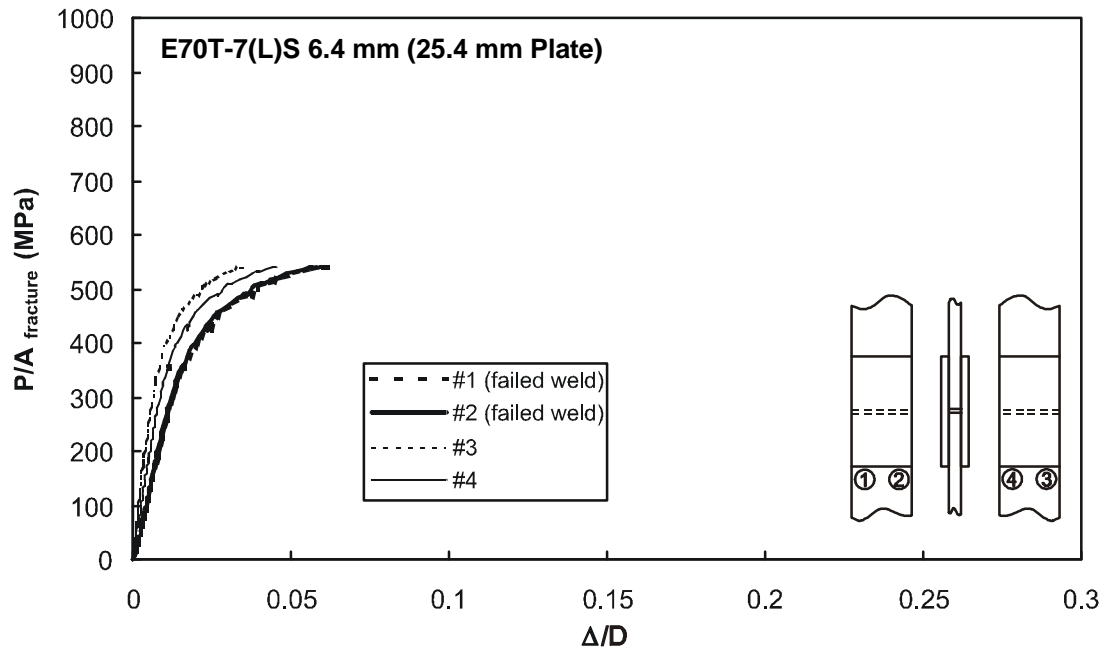

Figure F43 – Specimen T15-1 with 6.4 mm weld from E70T-7 electrode

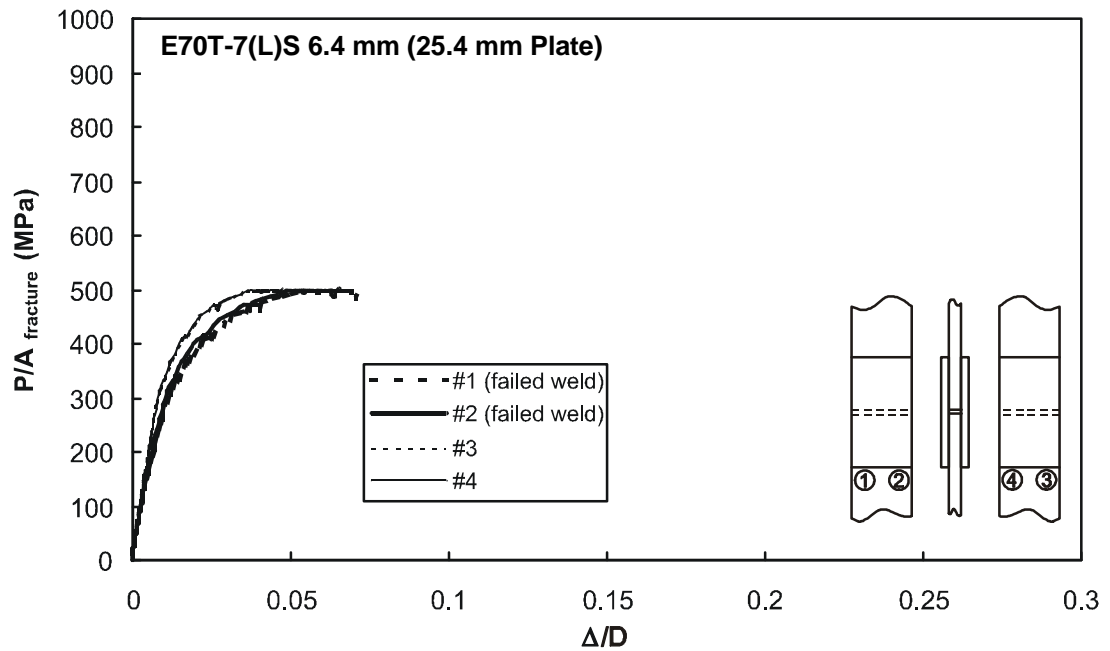

Figure F44 – Specimen T15-2 with 6.4 mm weld from E70T-7 electrode

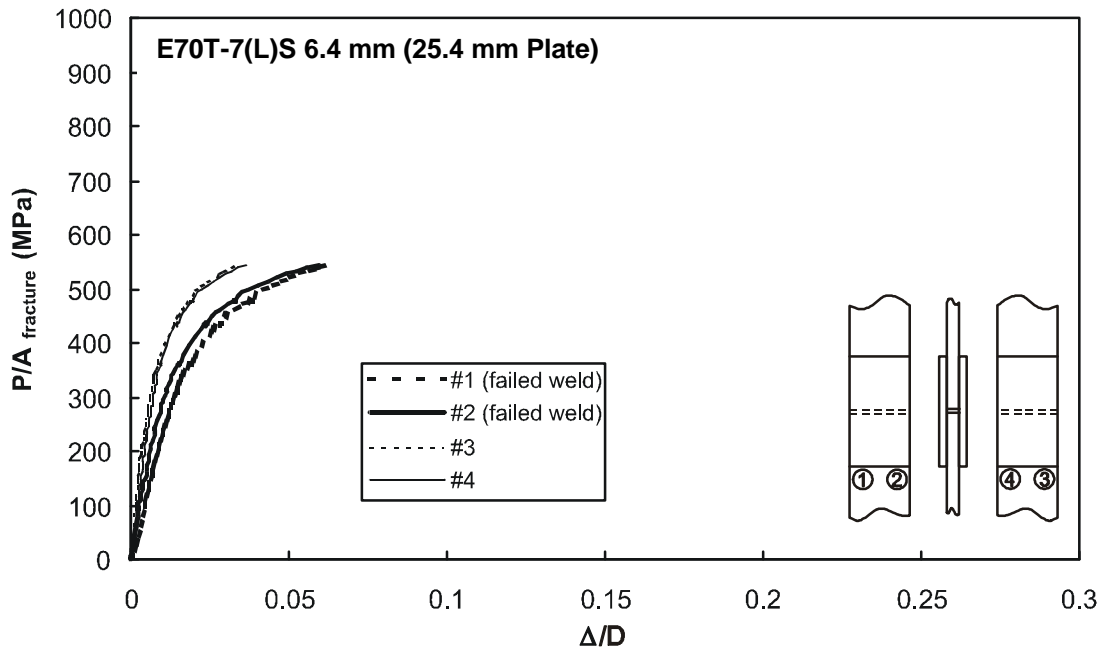

Figure F45 – Specimen T15-3 with 6.4 mm weld from E70T-7 electrode

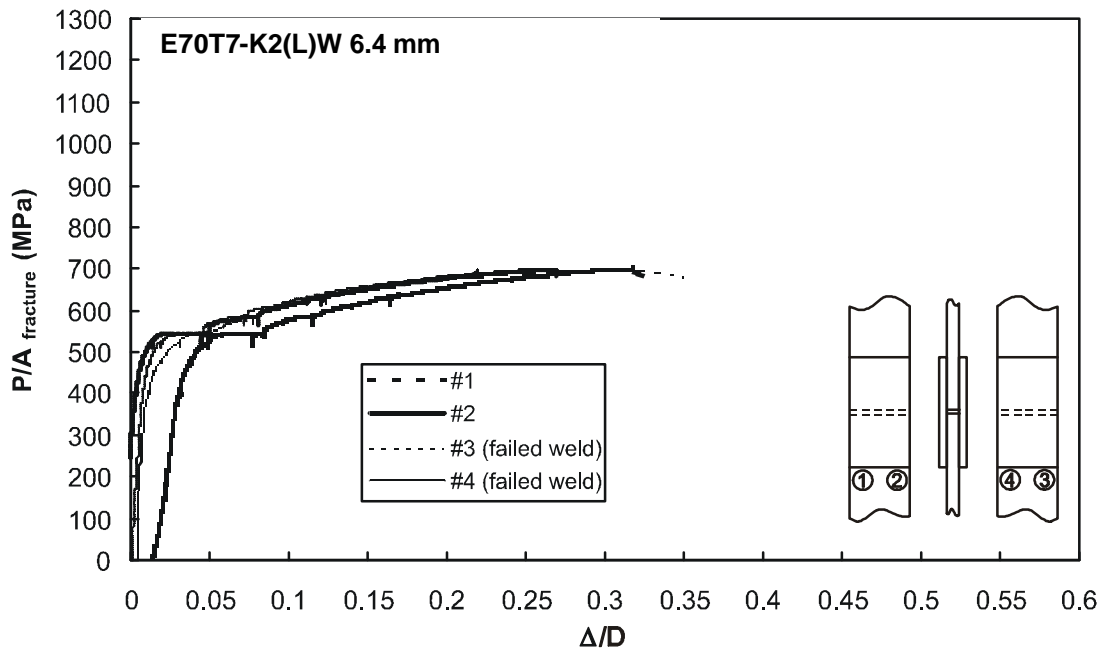

Figure F46 – Specimen T16-1 with 6.4 mm weld from E70T7-K2 electrode

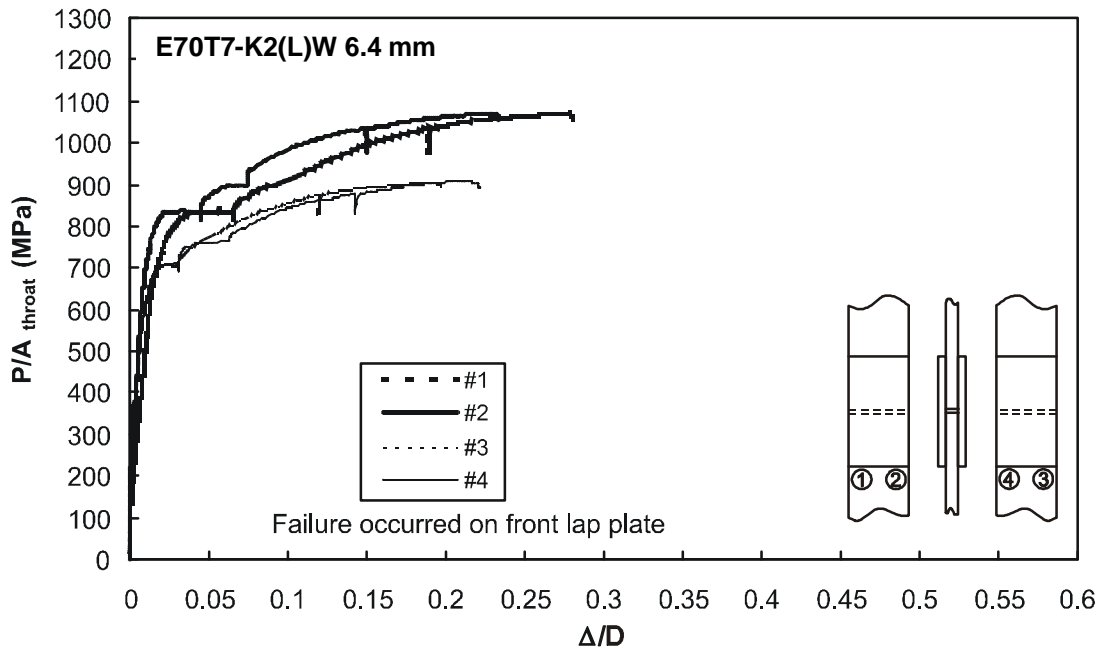

Figure F47 – Specimen T16-2 with 6.4 mm weld from E70T7-K2 electrode

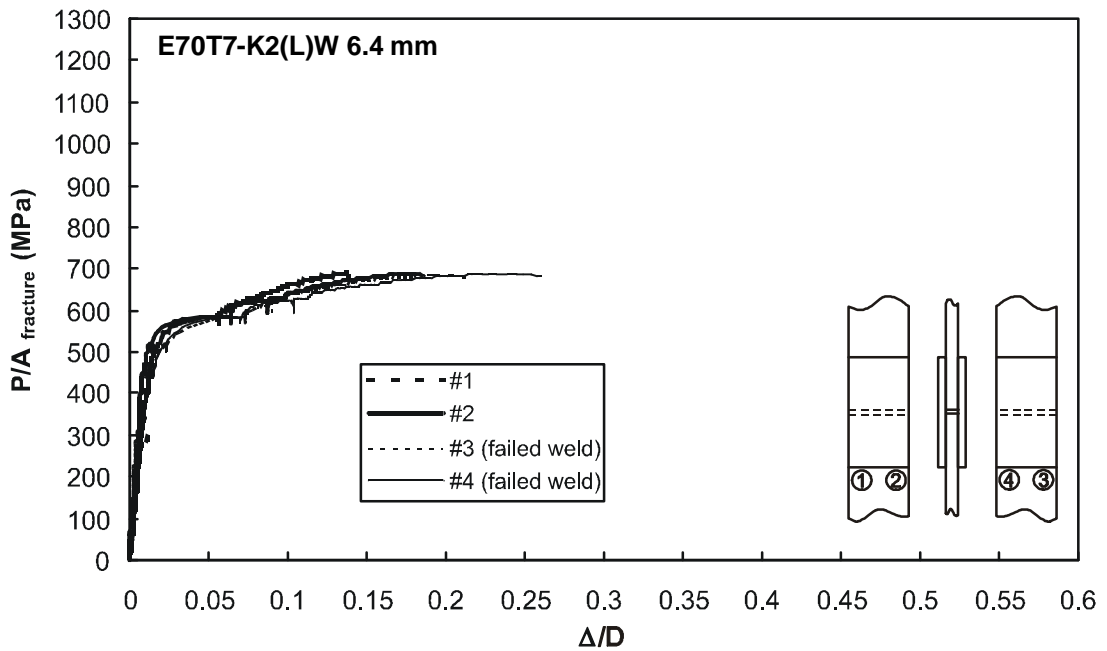

Figure F48 – Specimen T16-3 with 6.4 mm weld from E70T7-K2 electrode

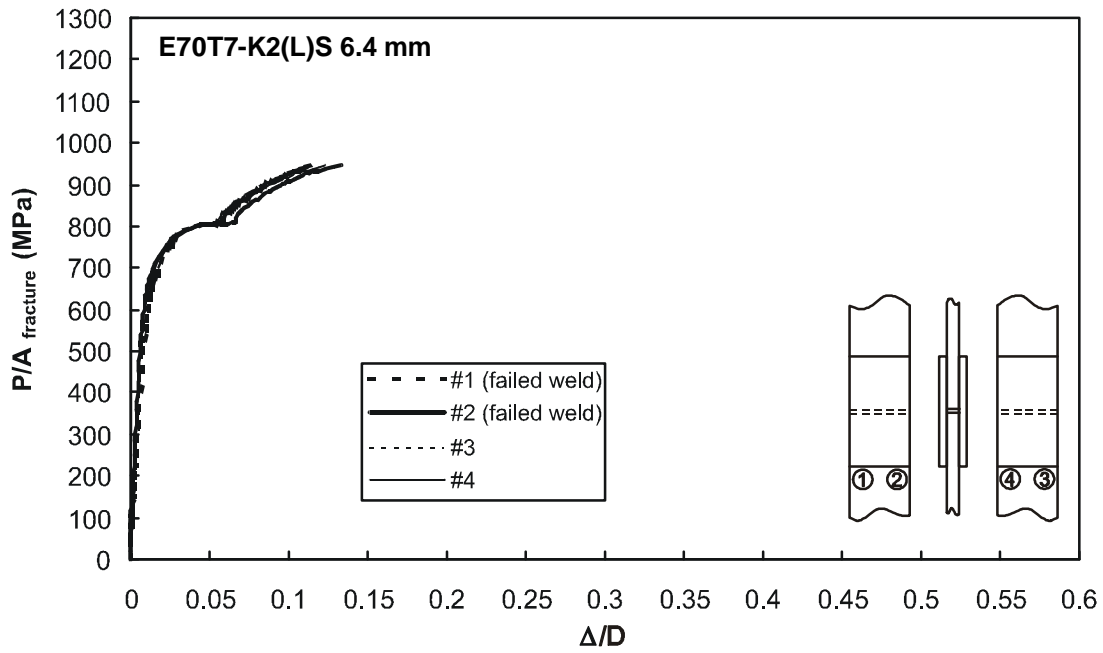

Figure F49 – Specimen T17-1 with 6.4 mm weld from E70T7-K2 electrode

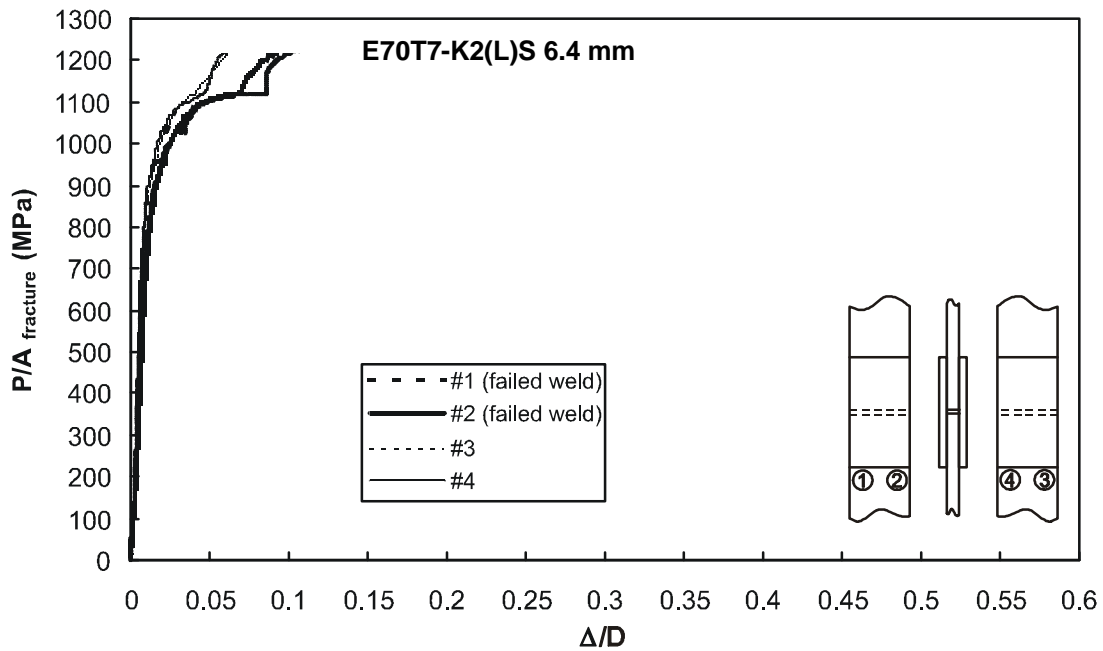

Figure F50 – Specimen T17-2 with 6.4 mm weld from E70T7-K2 electrode

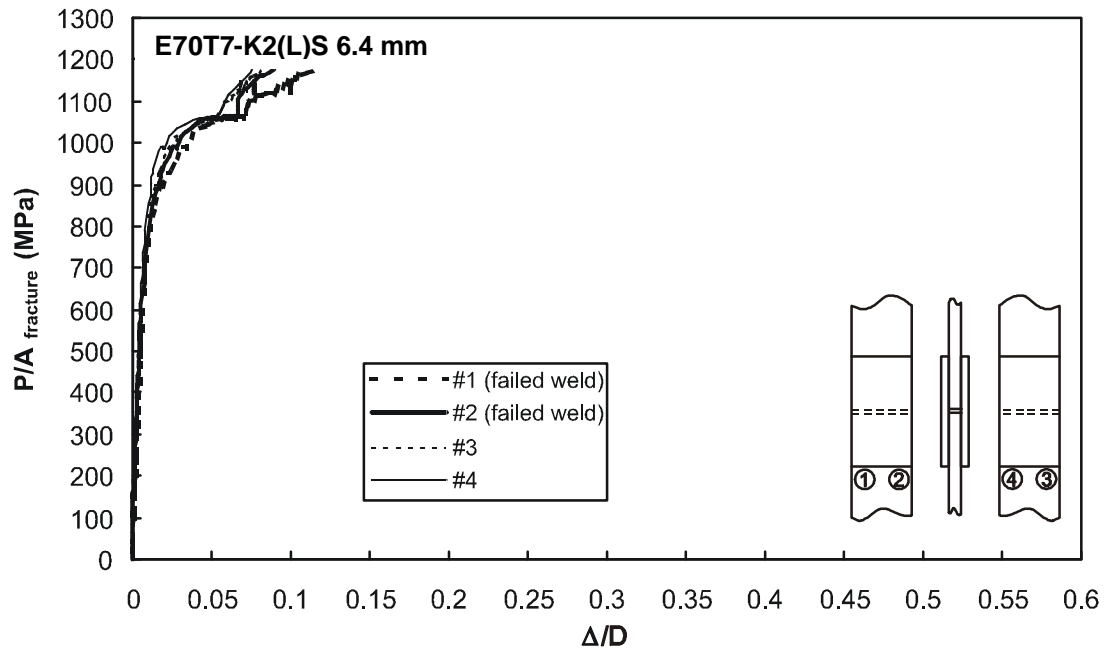

Figure F51 – Specimen T17-3 with 6.4 mm weld from E70T7-K2 electrode

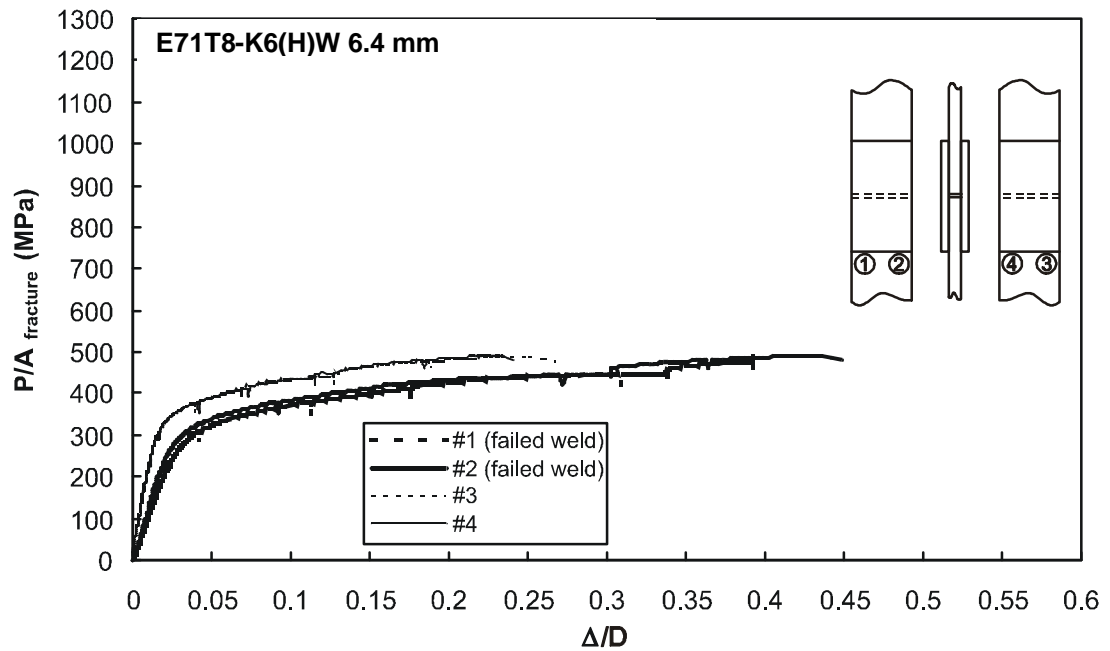

Figure F52 – Specimen T18-1 with 6.4 mm weld from E71T8-K6 electrode

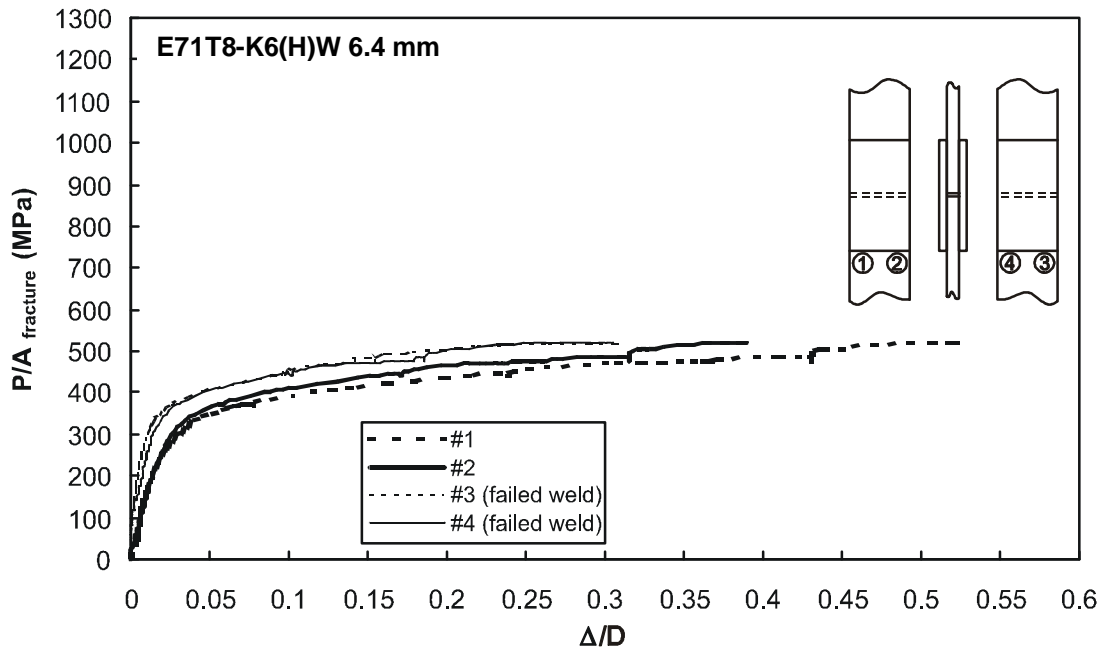

Figure F53 – Specimen T18-2 with 6.4 mm weld from E71T8-K6 electrode

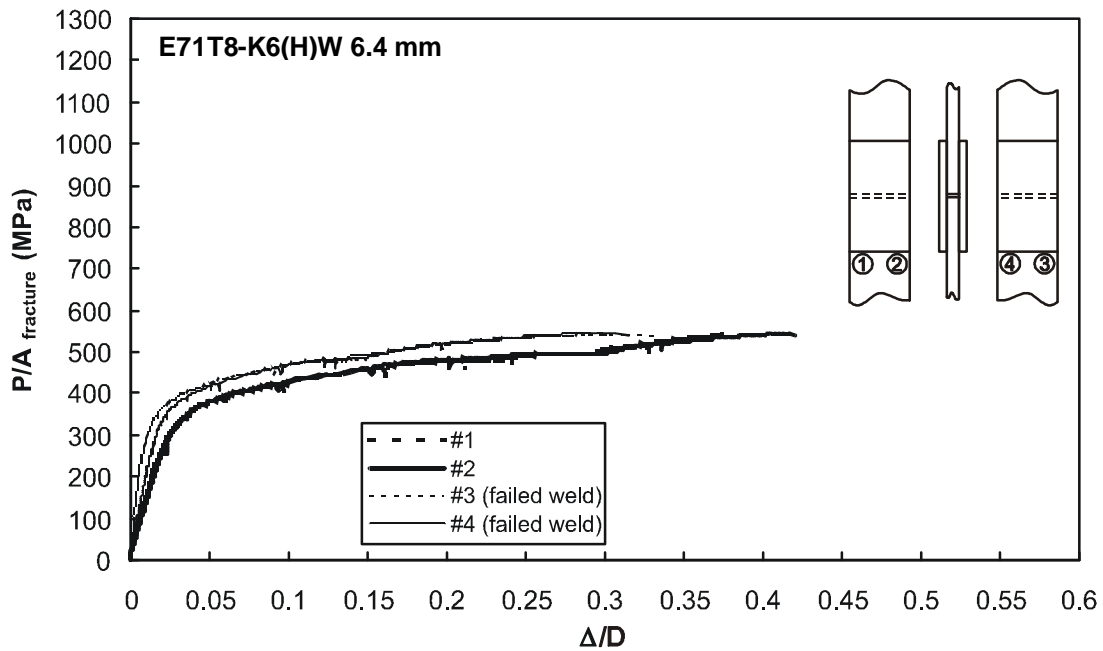

Figure F54 – Specimen T18-3 with 6.4 mm weld from E71T8-K6 electrode

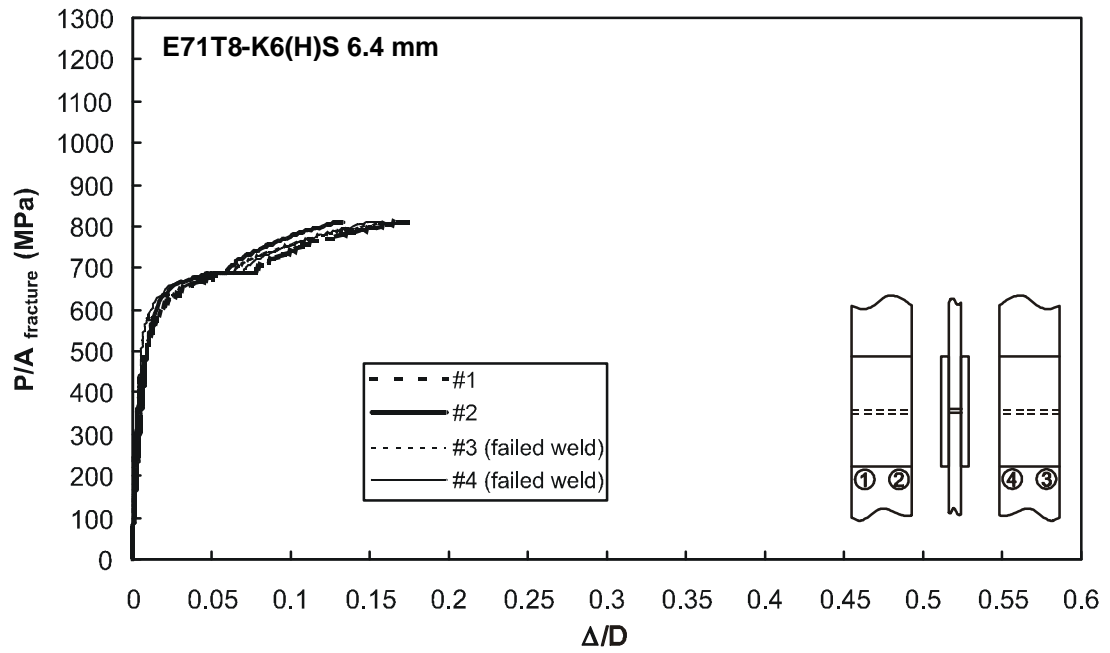

Figure F55 – Specimen T19-1 with 6.4 mm weld from E71T8-K6 electrode

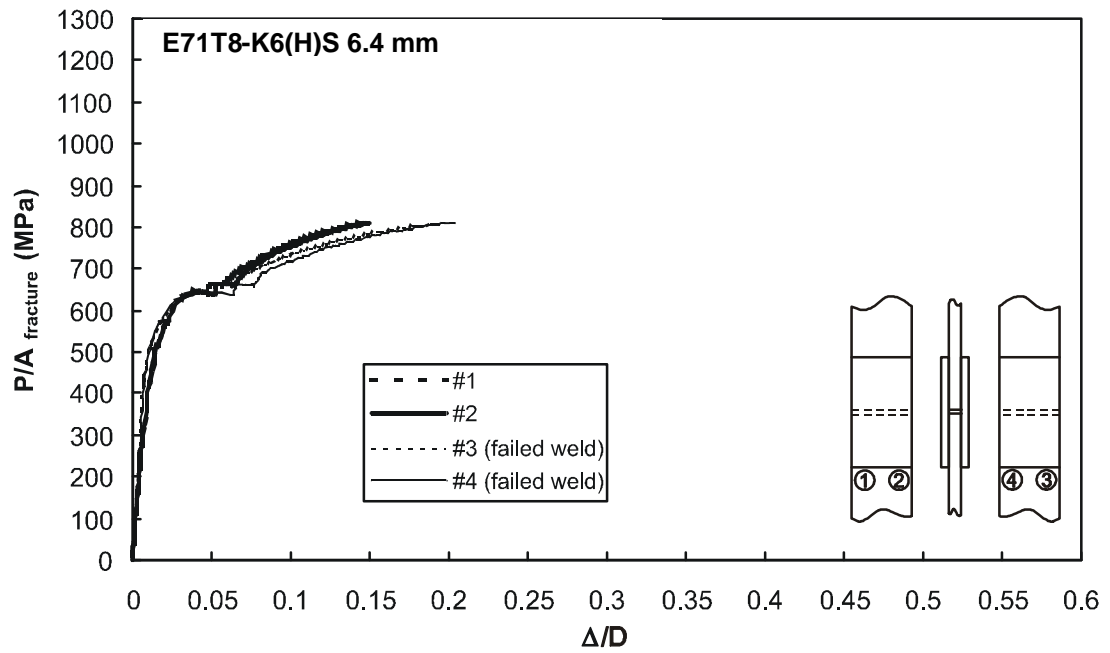

Figure F56 – Specimen T19-2 with 6.4 mm weld from E71T8-K6 electrode

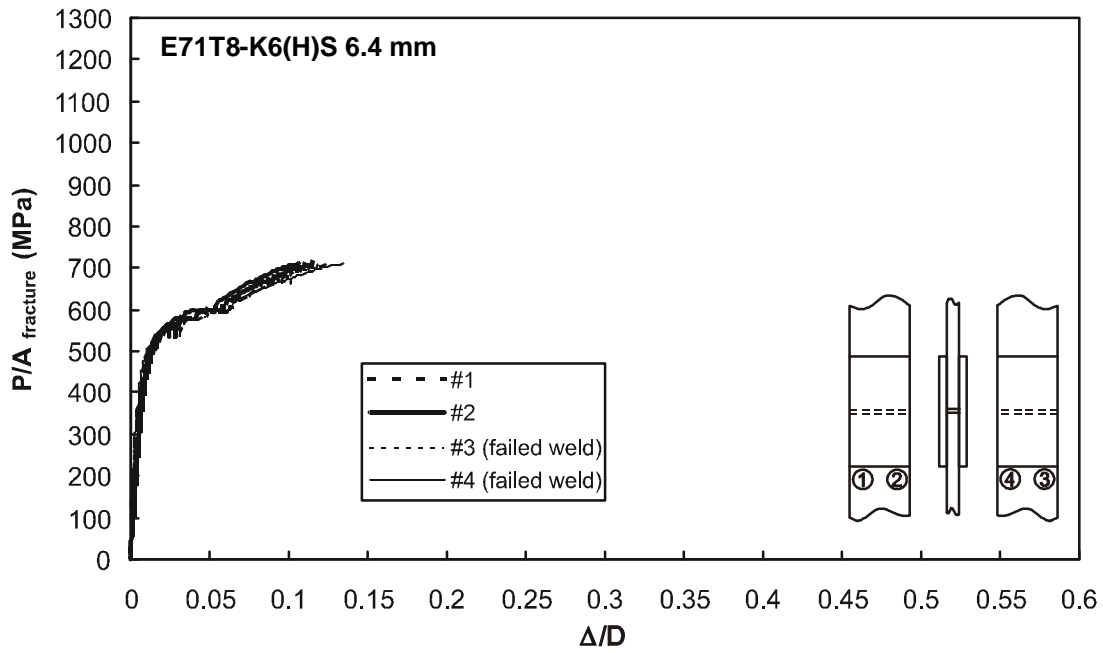

Figure F57 – Specimen T19-3 with 6.4 mm weld from E71T8-K6 electrode

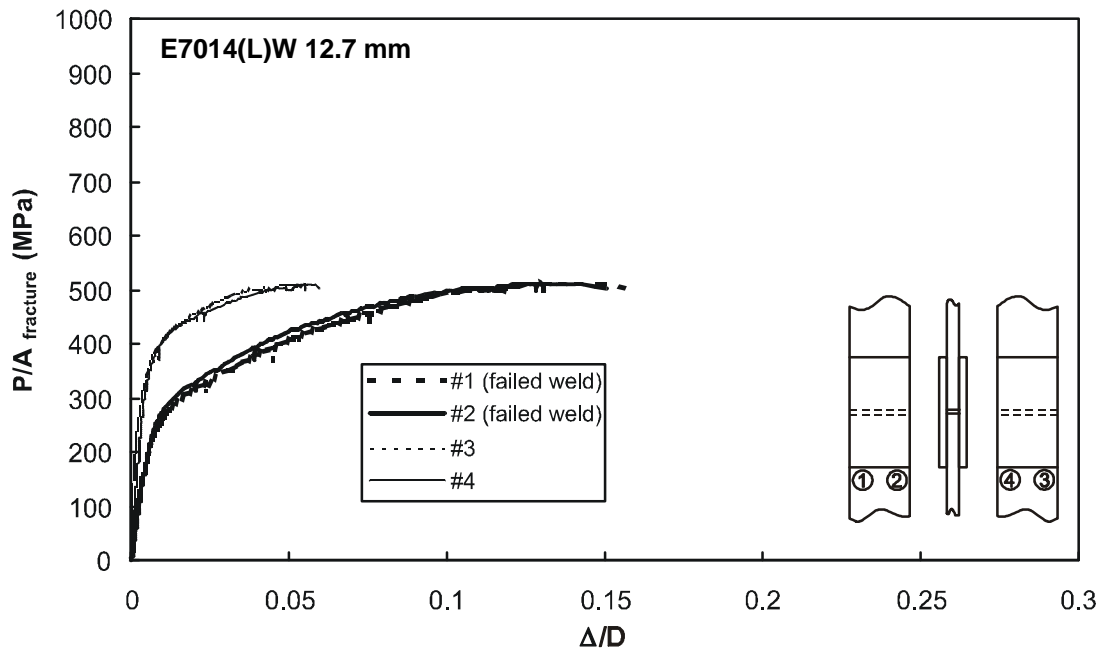

Figure F58 – Specimen T20-1 with 12.7 mm weld from E7014 electrode

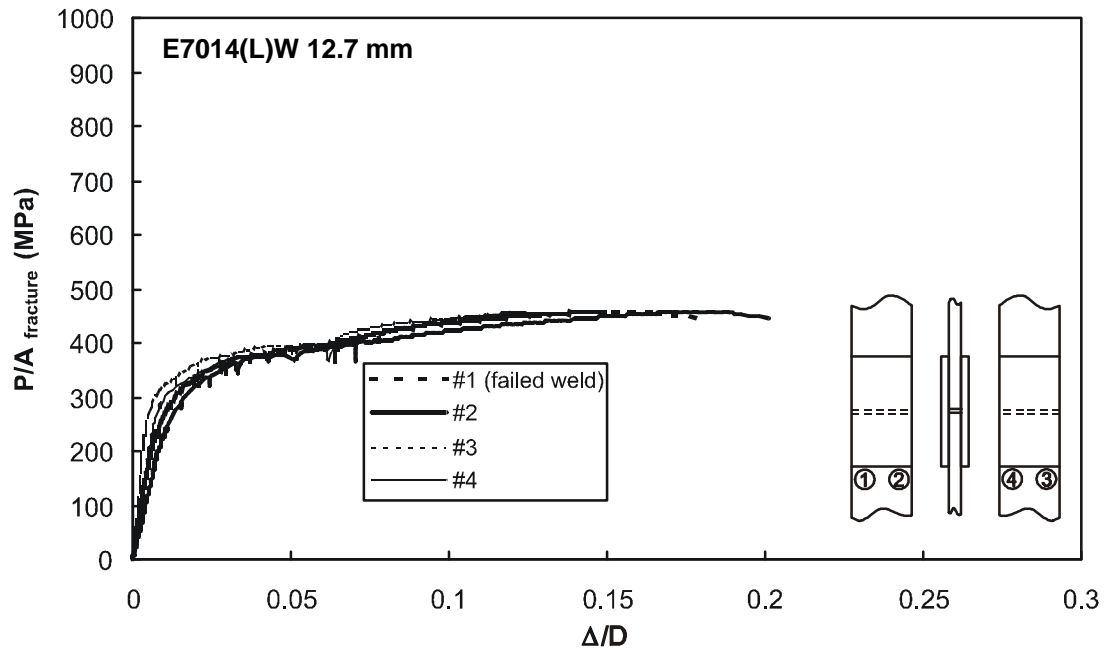

Figure F59 – Specimen T20-2 with 12.7 mm weld from E7014 electrode

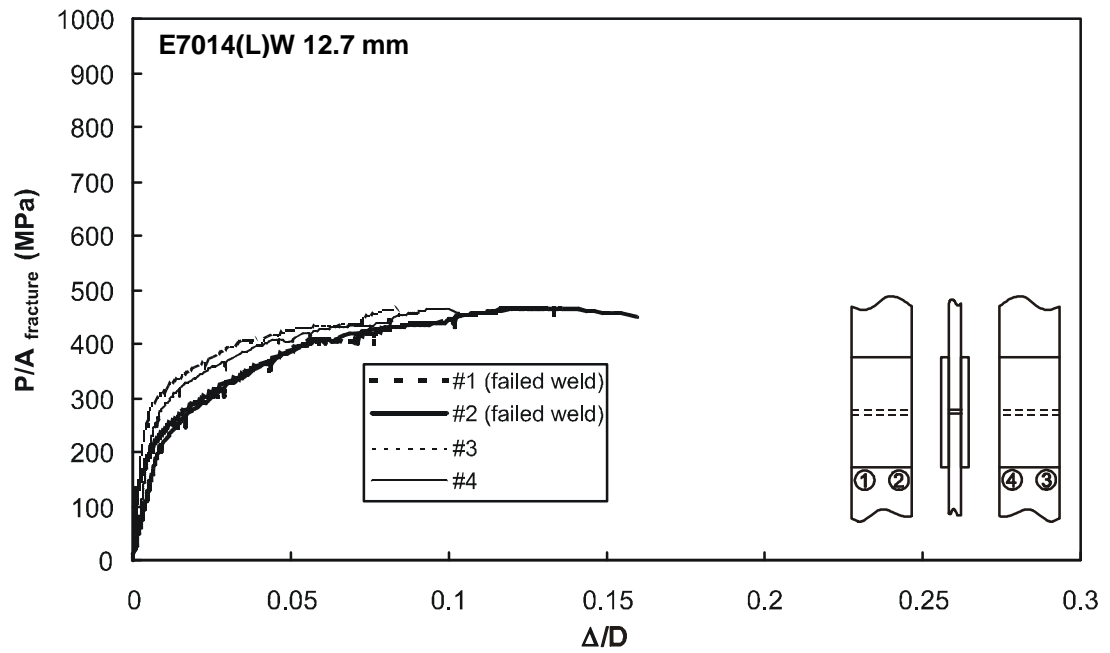

Figure F60 – Specimen T20-3 with 12.7 mm weld from E7014 electrode

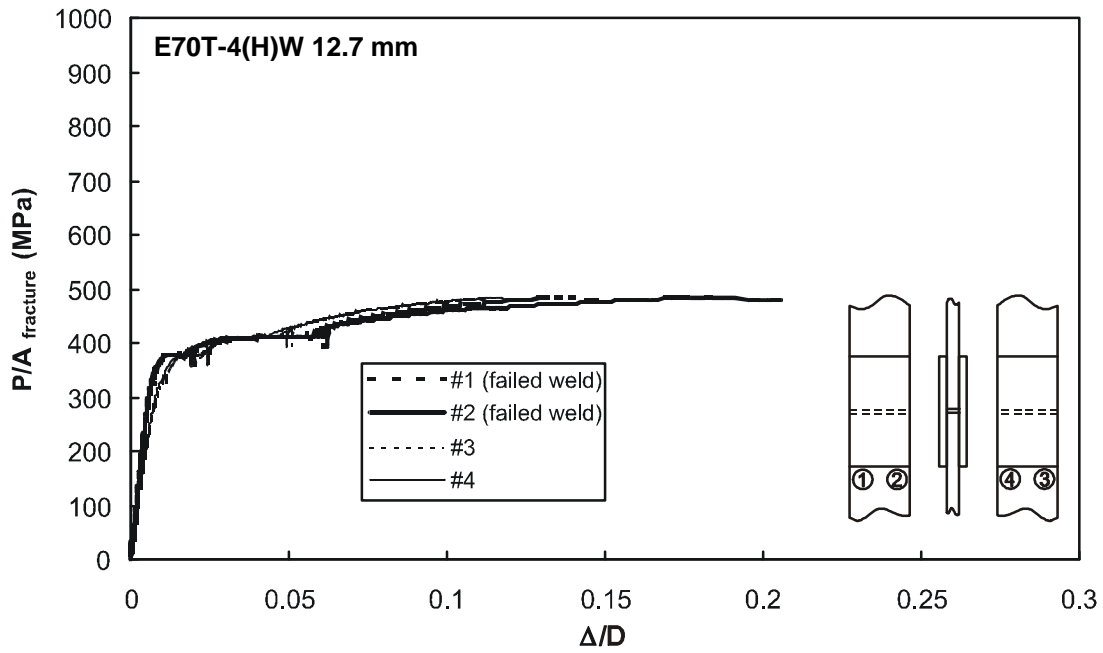

Figure F61 – Specimen T21-1 with 12.7 mm weld from E70T-4 electrode

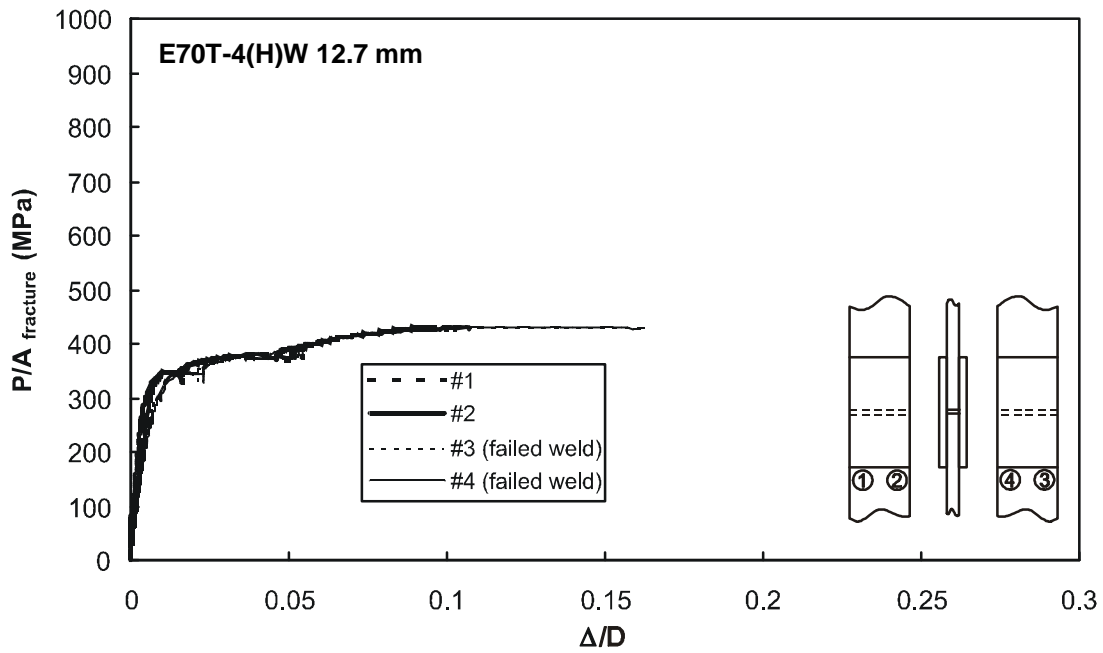

Figure F62 – Specimen T21-2 with 12.7 mm weld from E70T-4 electrode

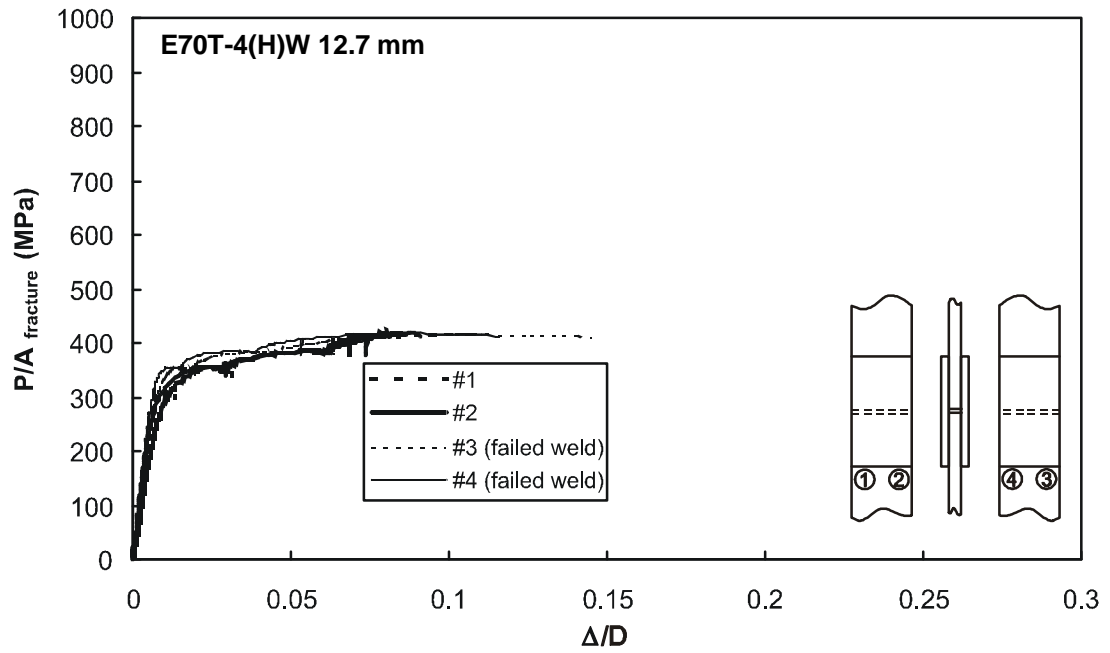

Figure F63 – Specimen T21-3 with 12.7 mm weld from E70T-4 electrode

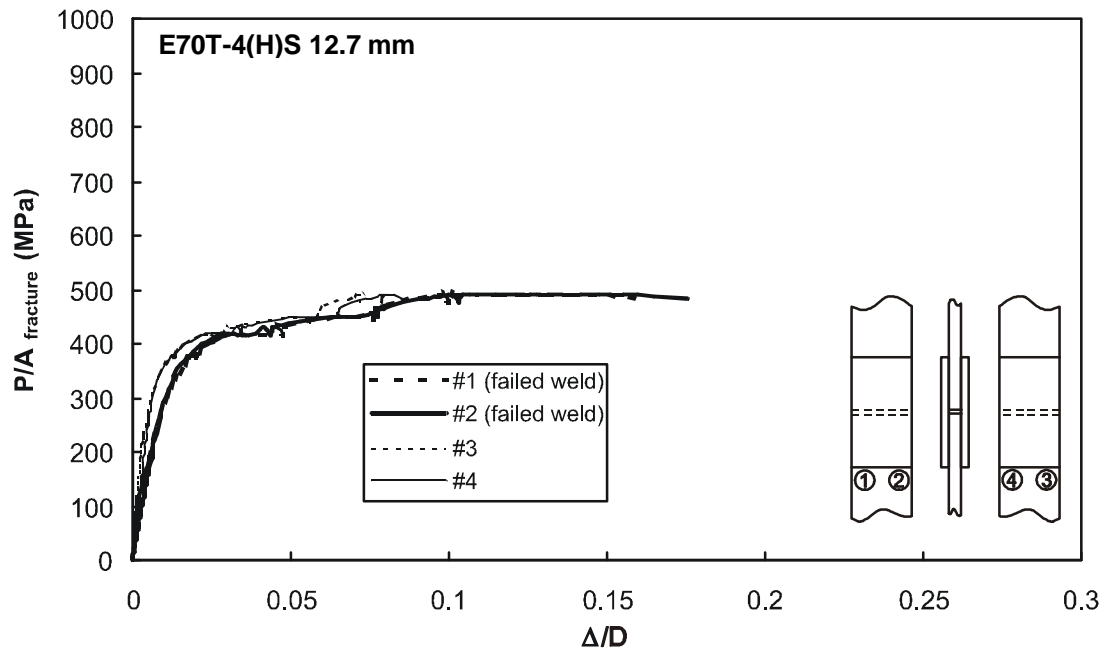

Figure F64 – Specimen T22-1 with 12.7 mm weld from E70T-4 electrode

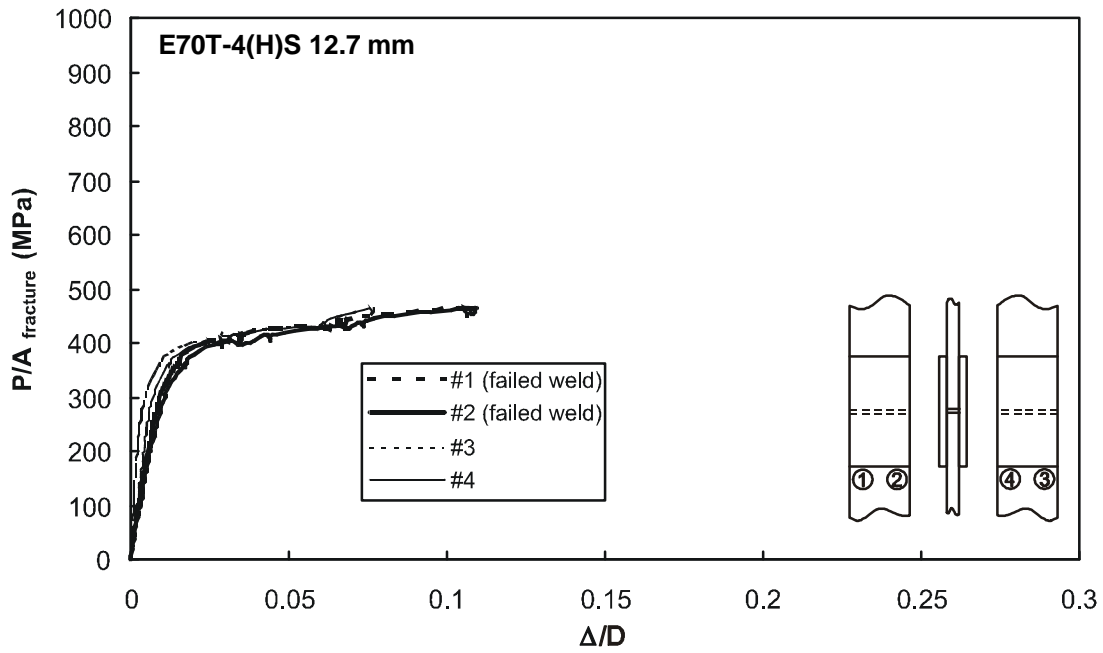

Figure F65 – Specimen T22-2 with 12.7 mm weld from E70T-4 electrode

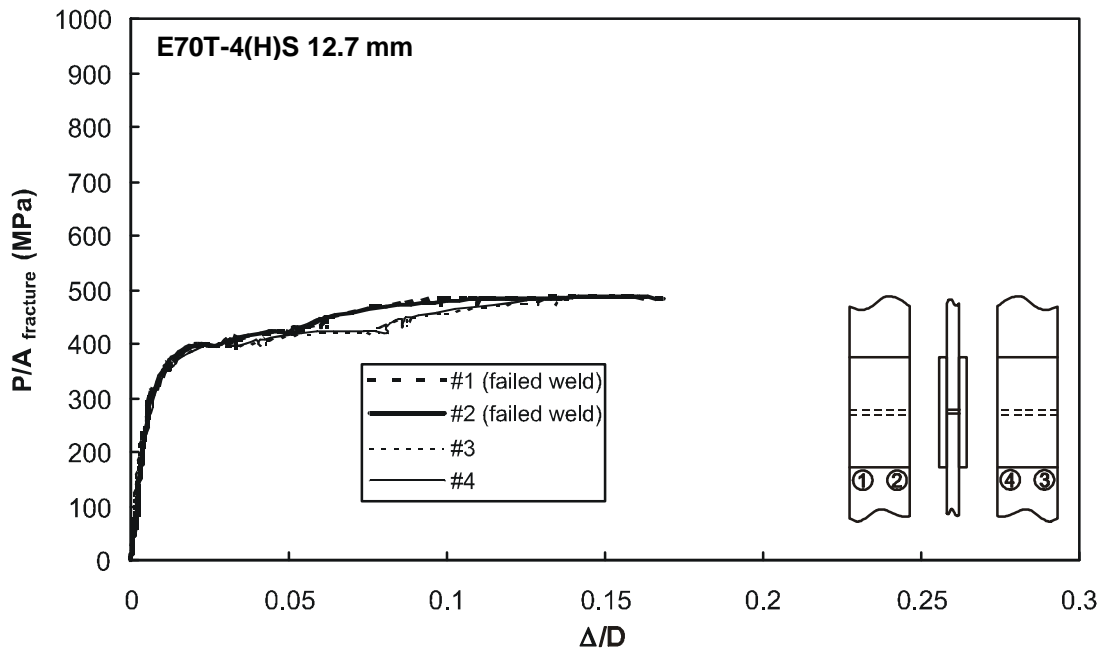

Figure F66 – Specimen T22-3 with 12.7 mm weld from E70T-4 electrode

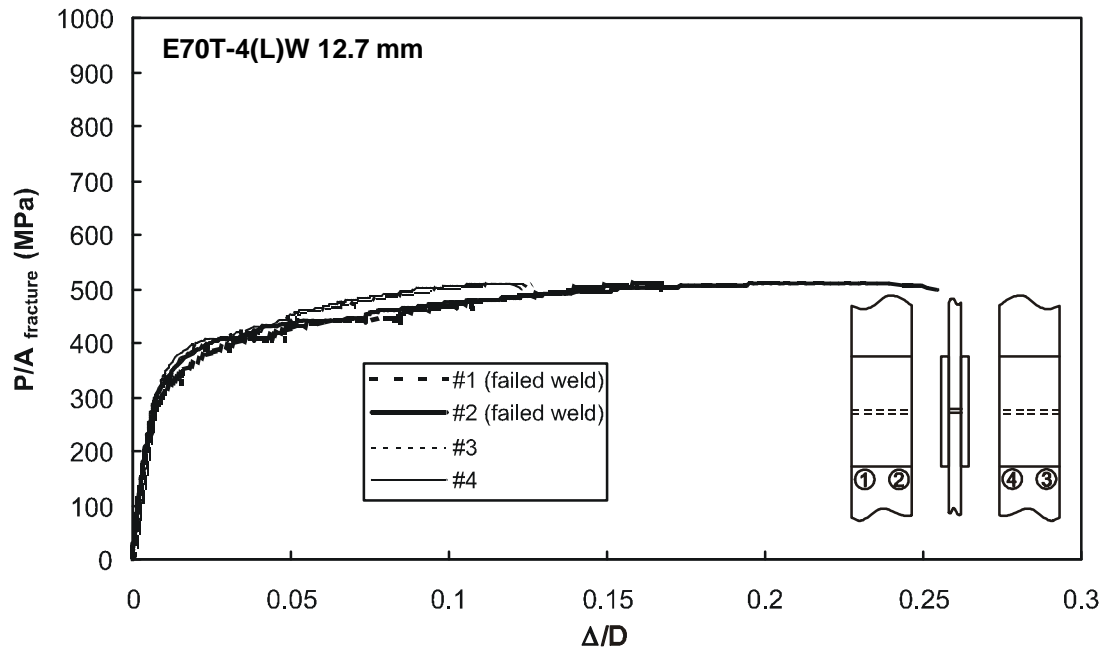

Figure F67 – Specimen T23-1 with 12.7 mm weld from E70T-4 electrode

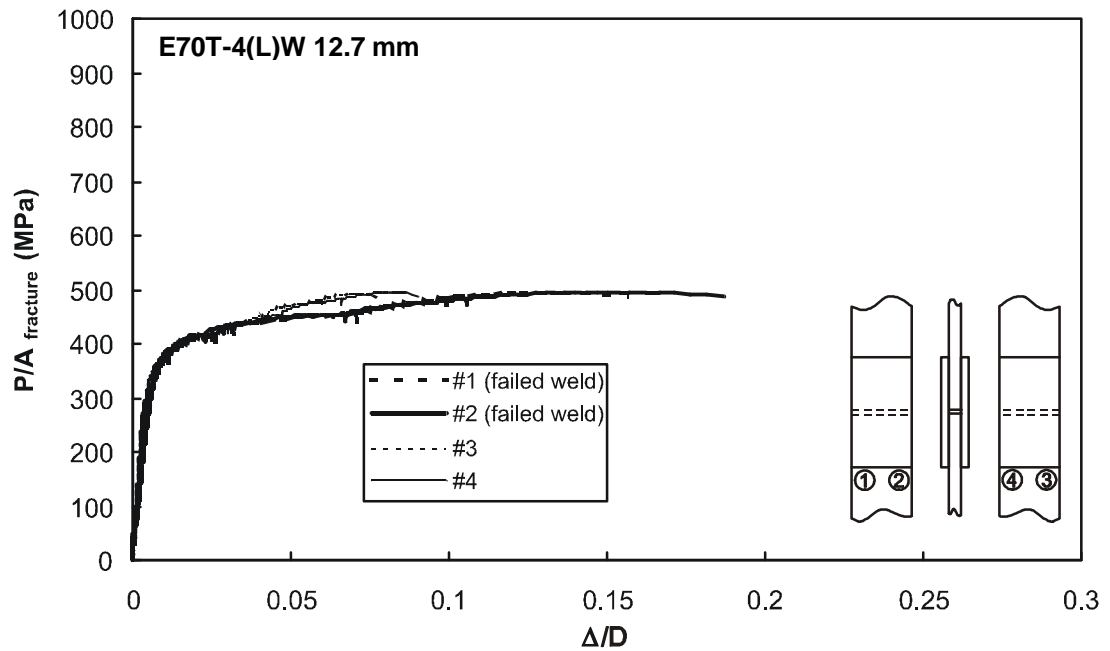

Figure F68 – Specimen T23-2 with 12.7 mm weld from E70T-4 electrode

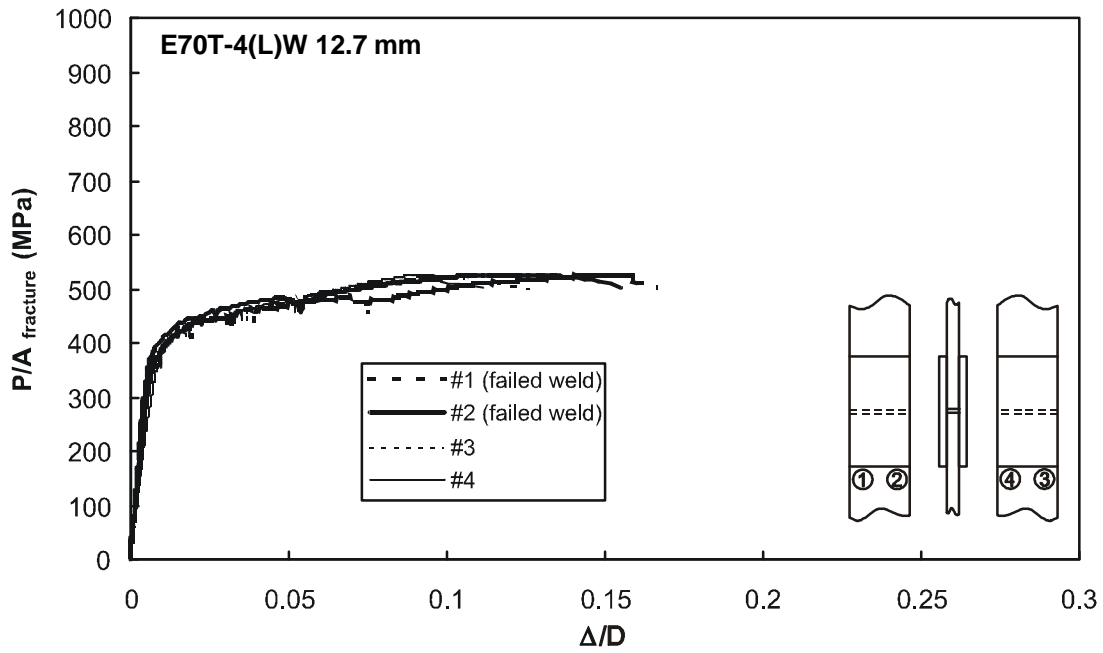

Figure F69 – Specimen T23-3 with 12.7 mm weld from E70T-4 electrode

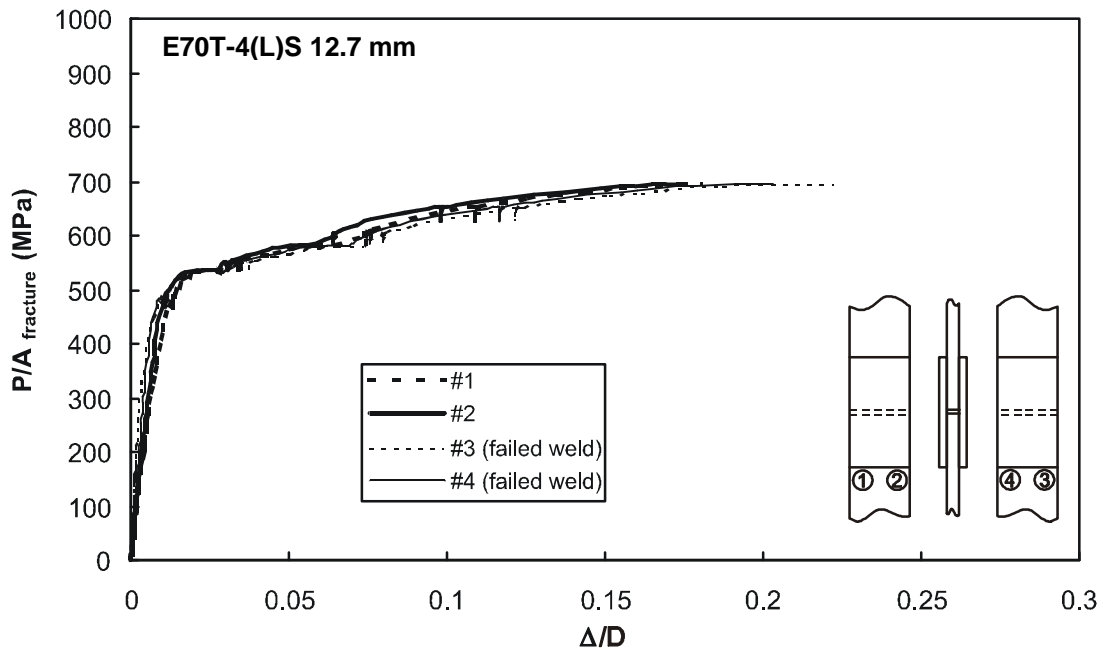

Figure F70 – Specimen T24-1 with 12.7 mm weld from E70T-4 electrode

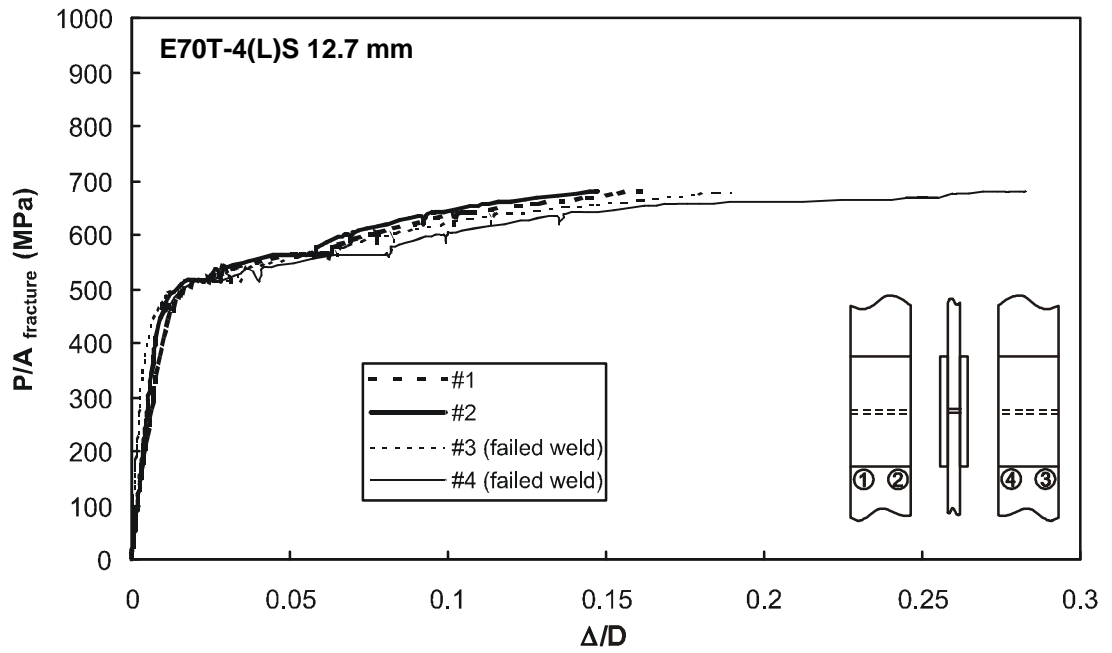

Figure F71 – Specimen T24-2 with 12.7 mm weld from E70T-4 electrode

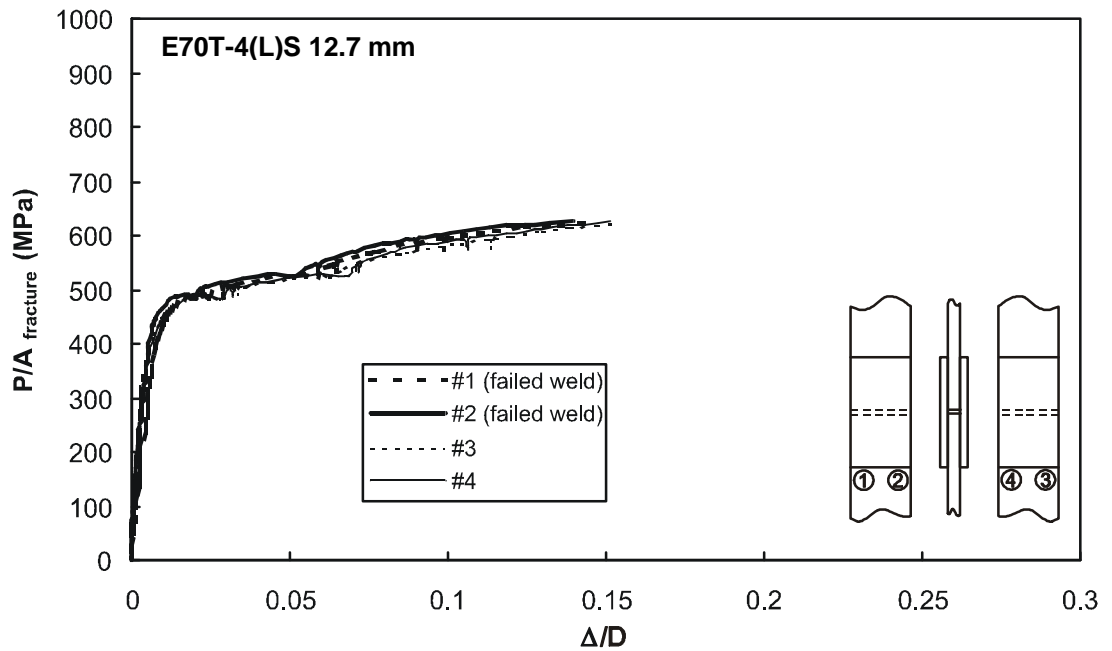

Figure F72 – Specimen T24-3 with 12.7 mm weld from E70T-4 electrode

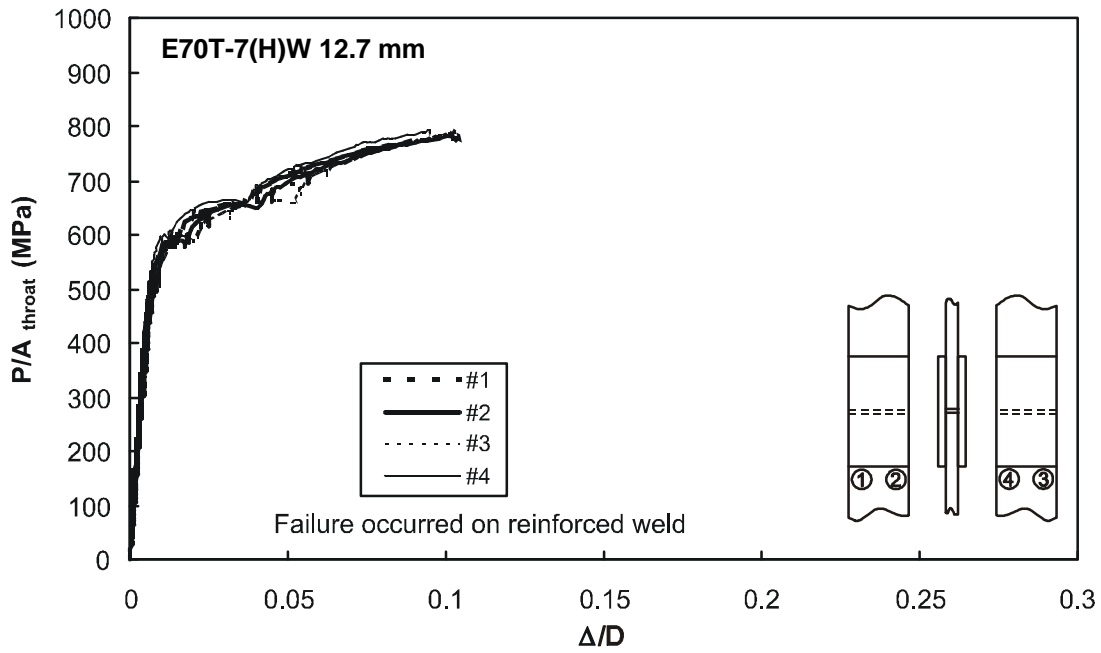

Figure F73 – Specimen T25-1 with 12.7 mm weld from E70T-7 electrode

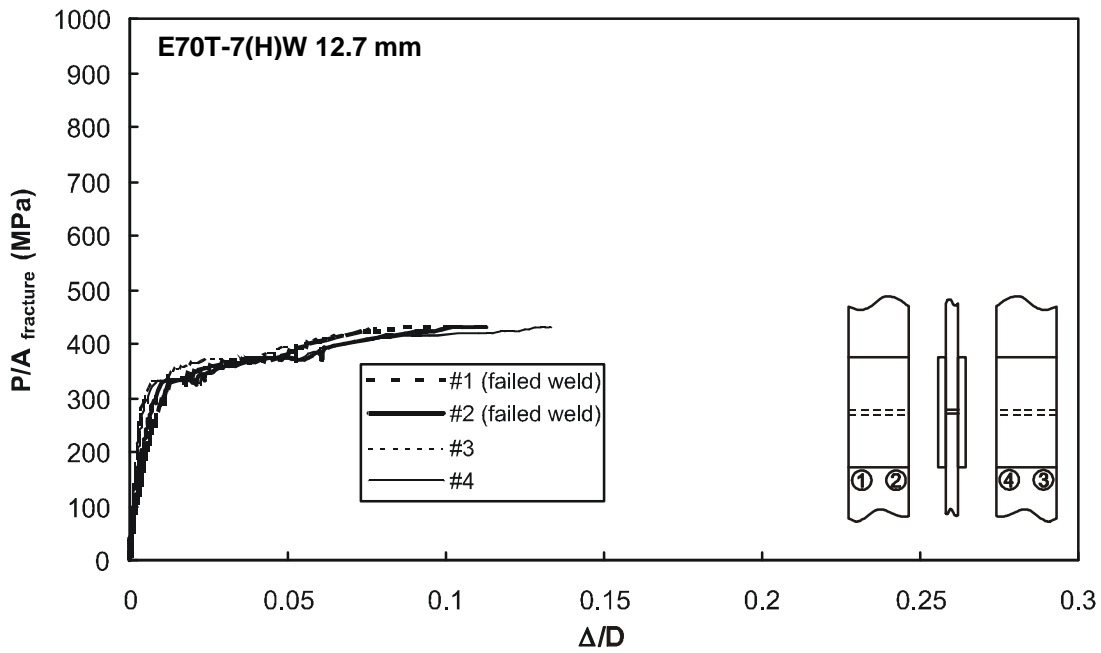

Figure F74 – Specimen T25-2 with 12.7 mm weld from E70T-7 electrode

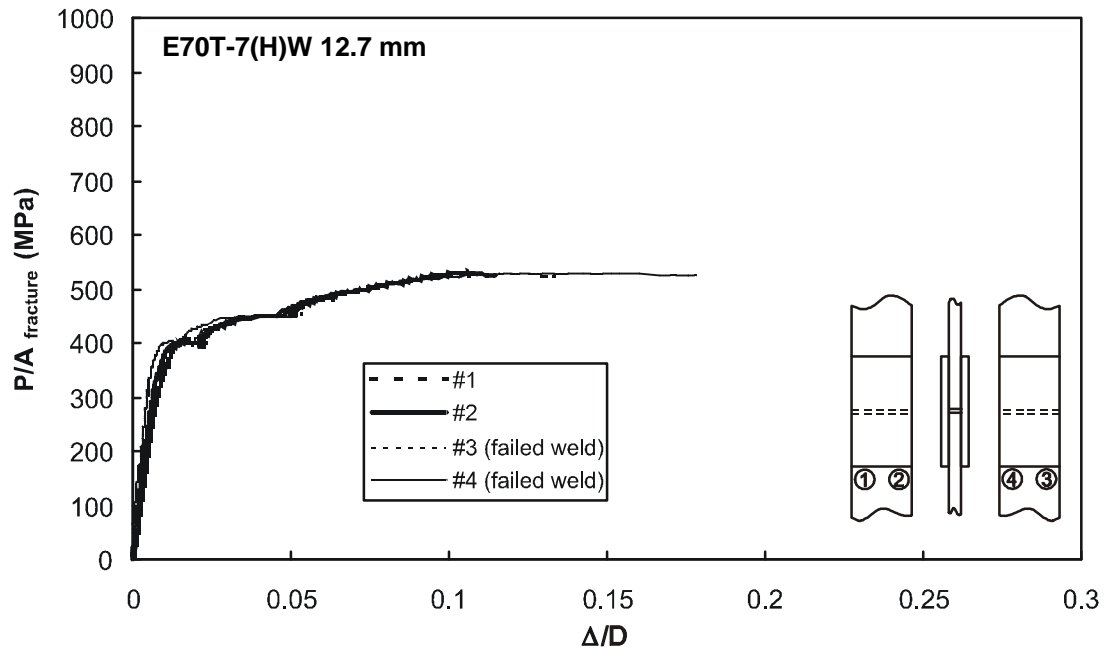

Figure F75 – Specimen T25-3 with 12.7 mm weld from E70T-7 electrode

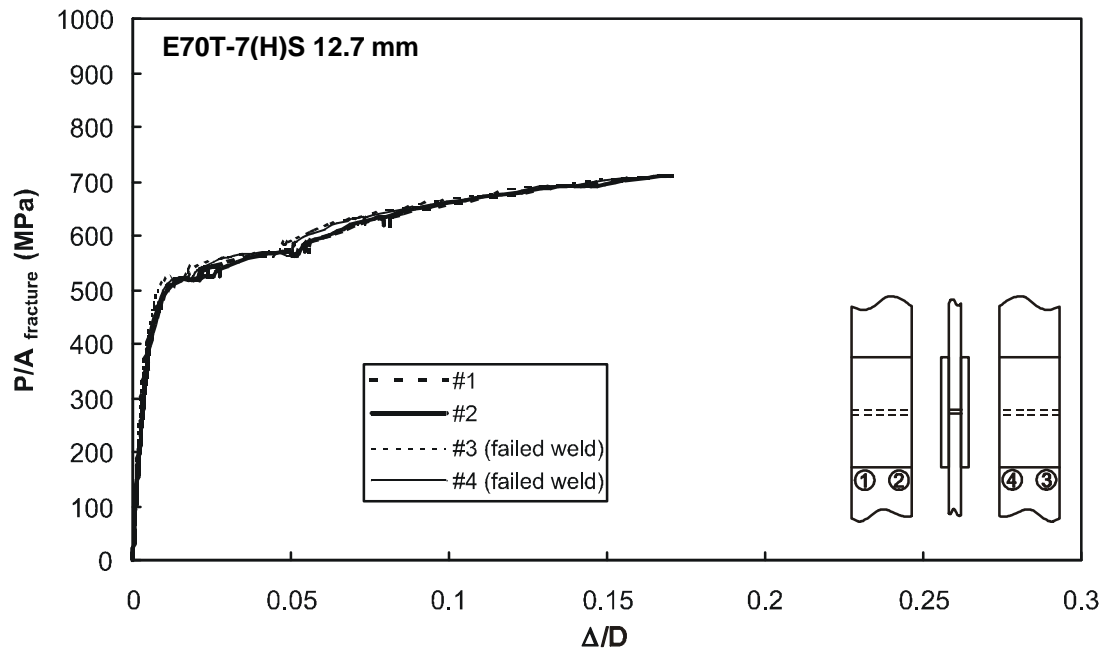

Figure F76 – Specimen T26-1 with 12.7 mm weld from E70T-7 electrode

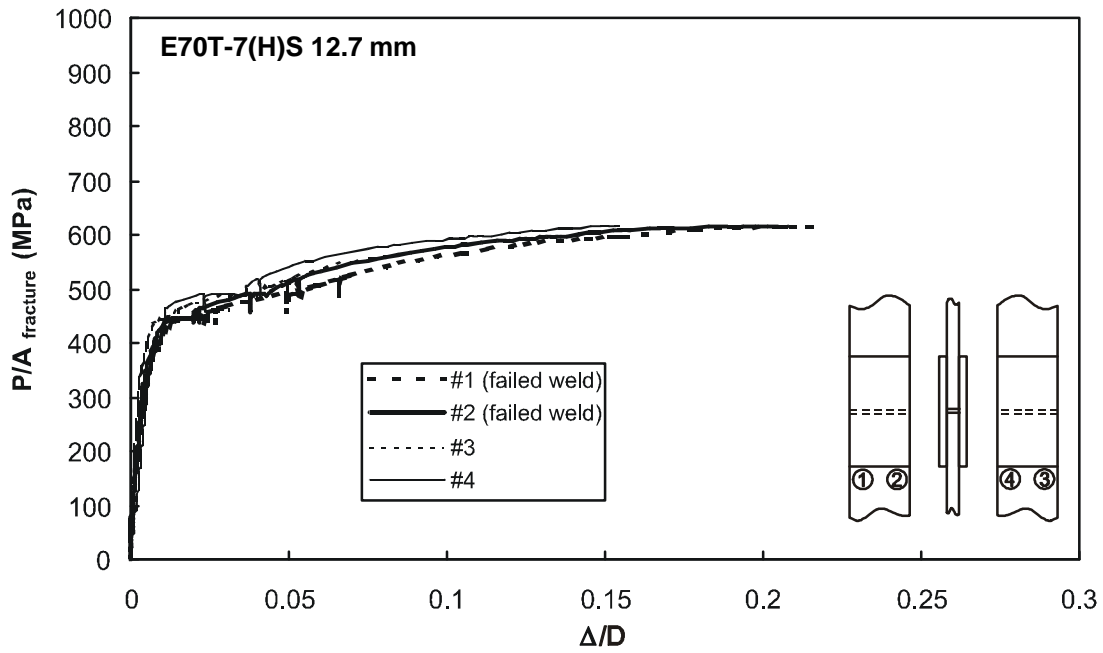

Figure F77 – Specimen T26-2 with 12.7 mm weld from E70T-7 electrode

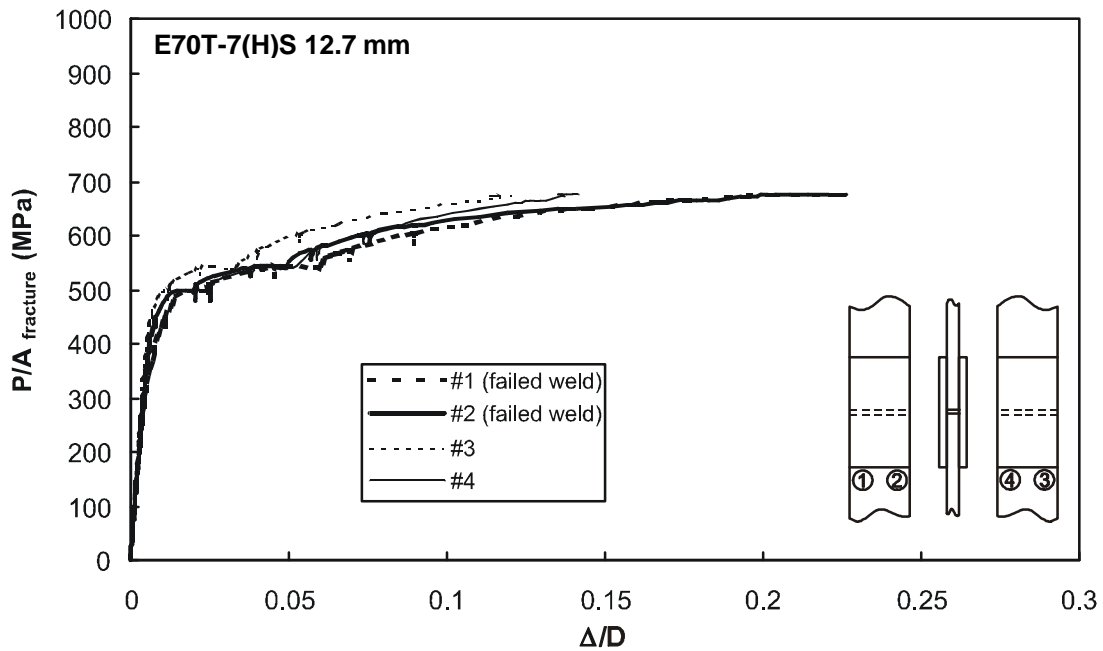

Figure F78 – Specimen T26-3 with 12.7 mm weld from E70T-7 electrode

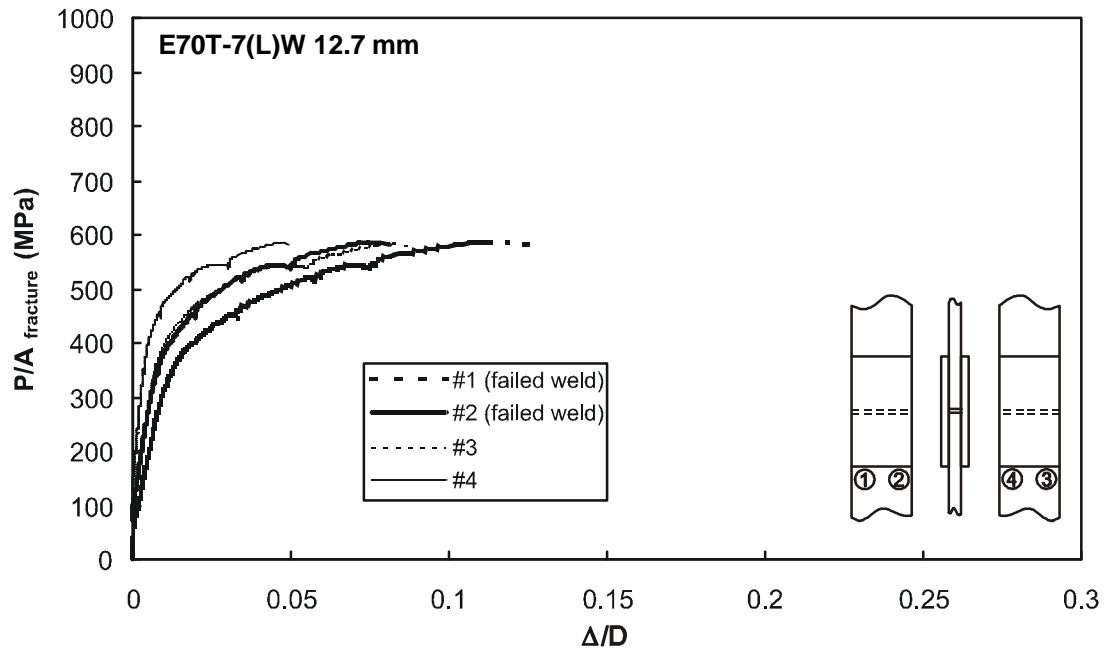

Figure F79 – Specimen T27-1 with 12.7 mm weld from E70T-7 electrode

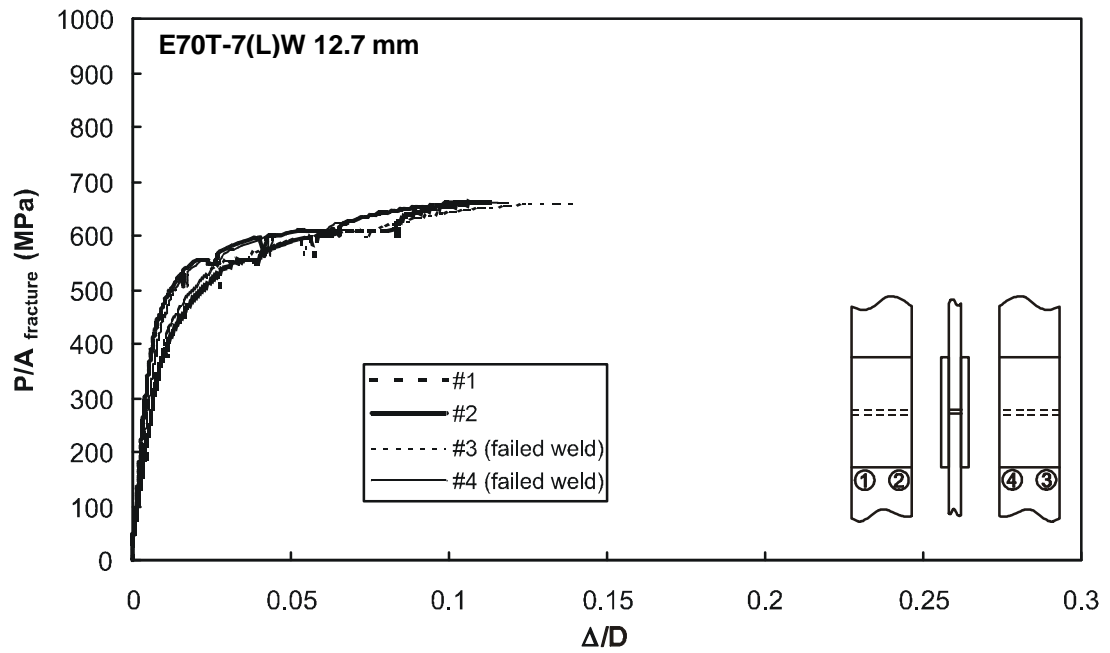

Figure F80 – Specimen T27-2 with 12.7 mm weld from E70T-7 electrode

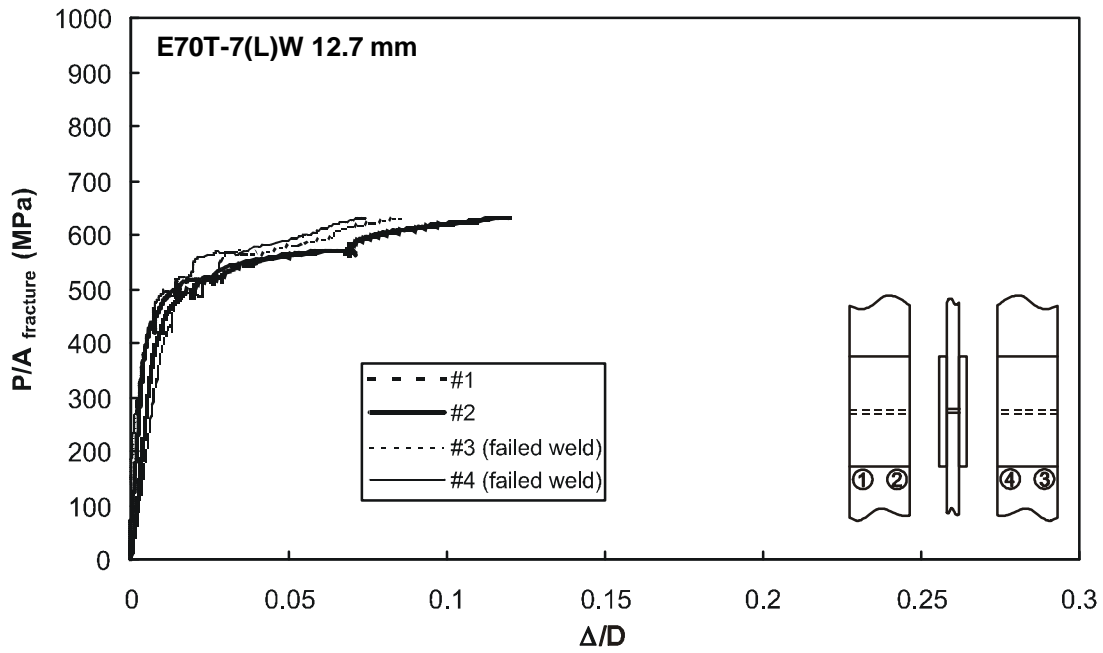

Figure F81 – Specimen T27-3 with 12.7 mm weld from E70T-7 electrode

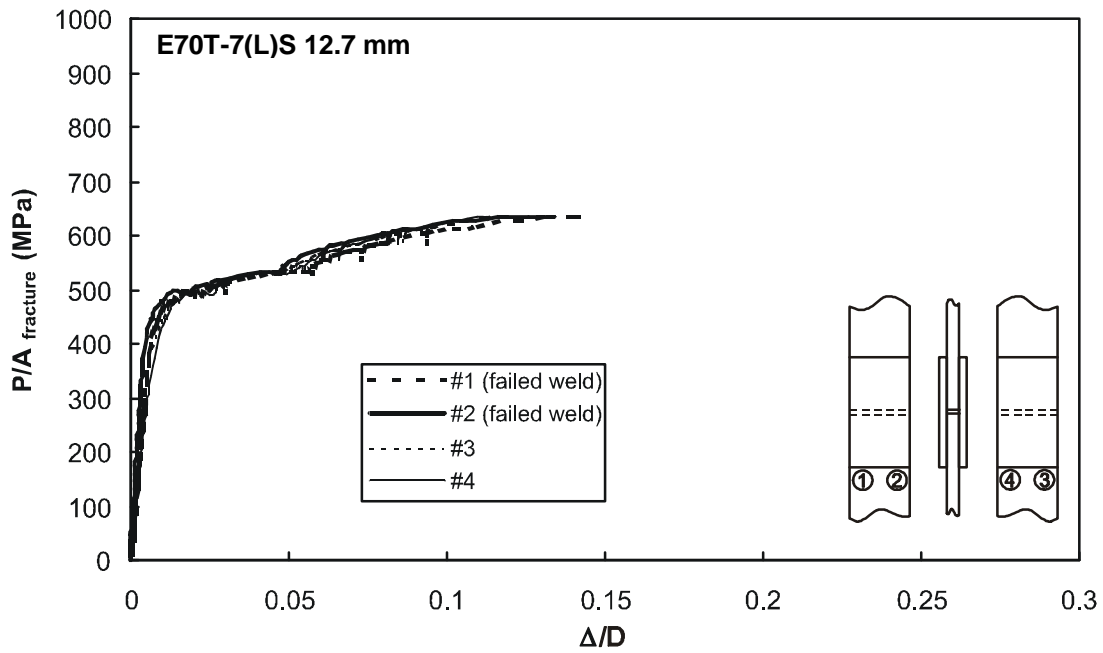

Figure F82 – Specimen T28-1 with 12.7 mm weld from E70T-7 electrode

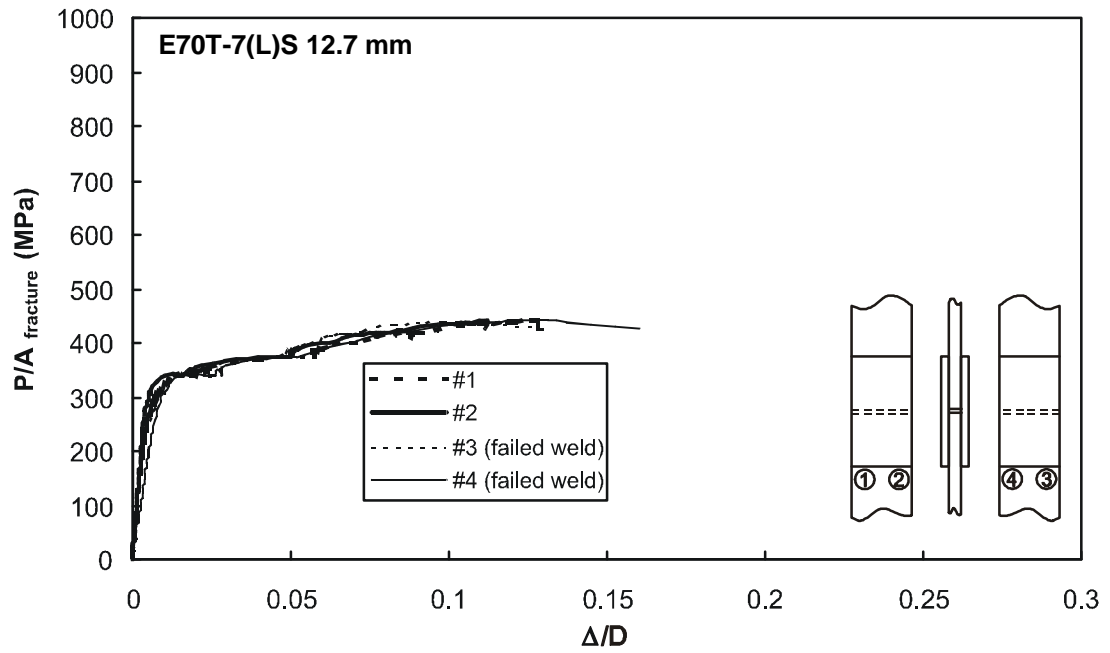

Figure F83 – Specimen T28-2 with 12.7 mm weld from E70T-7 electrode

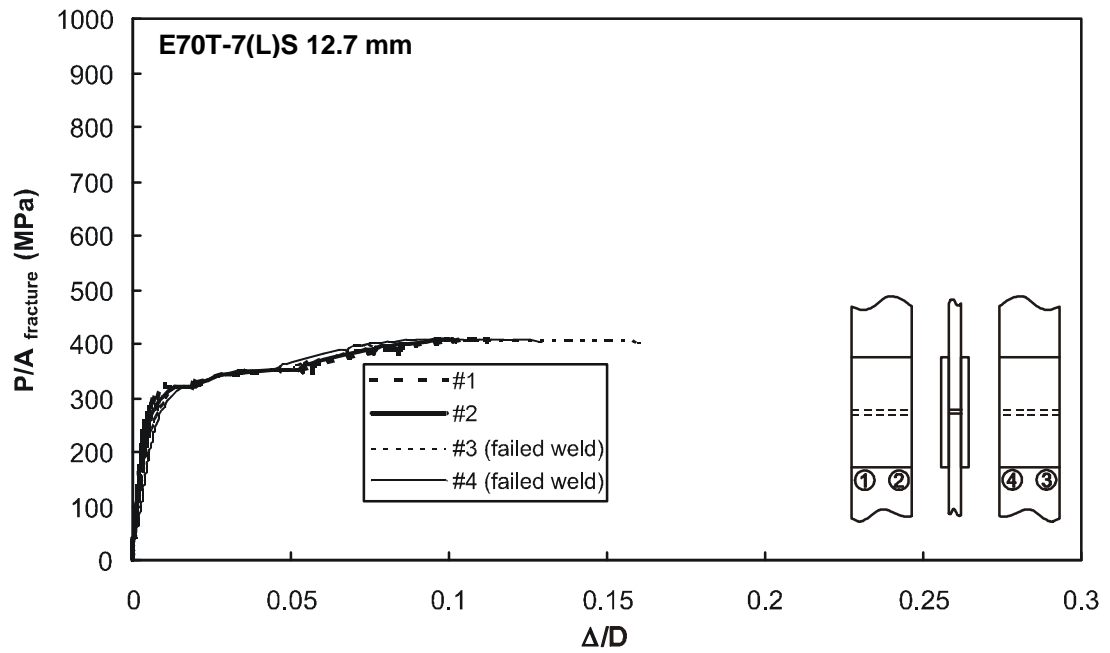

Figure F84 – Specimen T28-3 with 12.7 mm weld from E70T-7 electrode

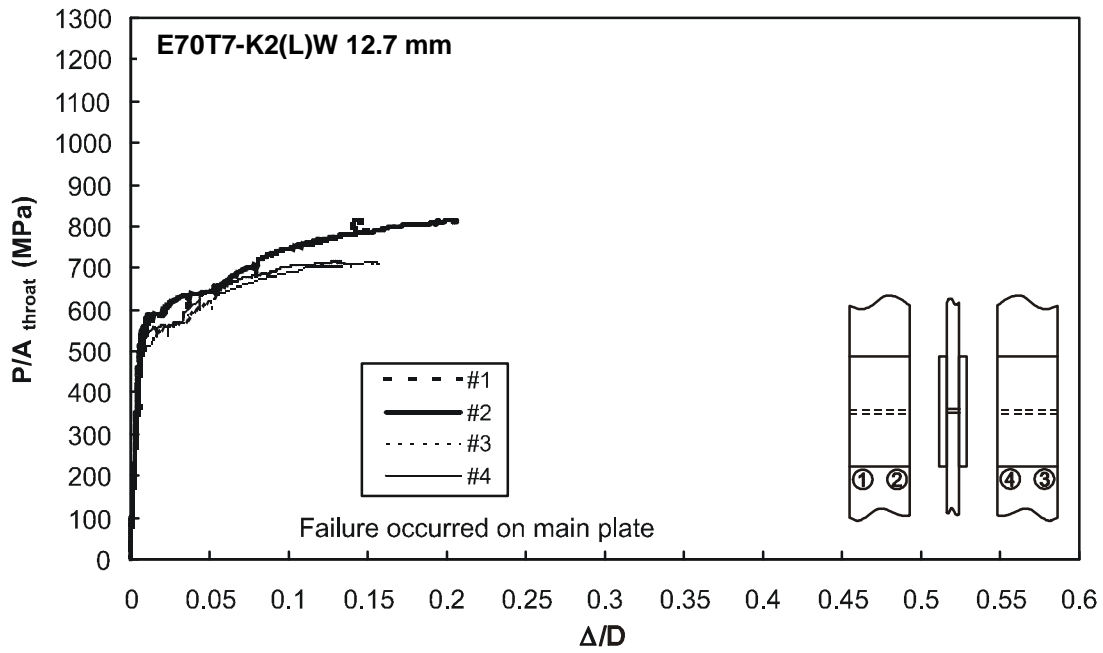

Figure F85 – Specimen T29-1 with 12.7 mm weld from E70T7-K2 electrode

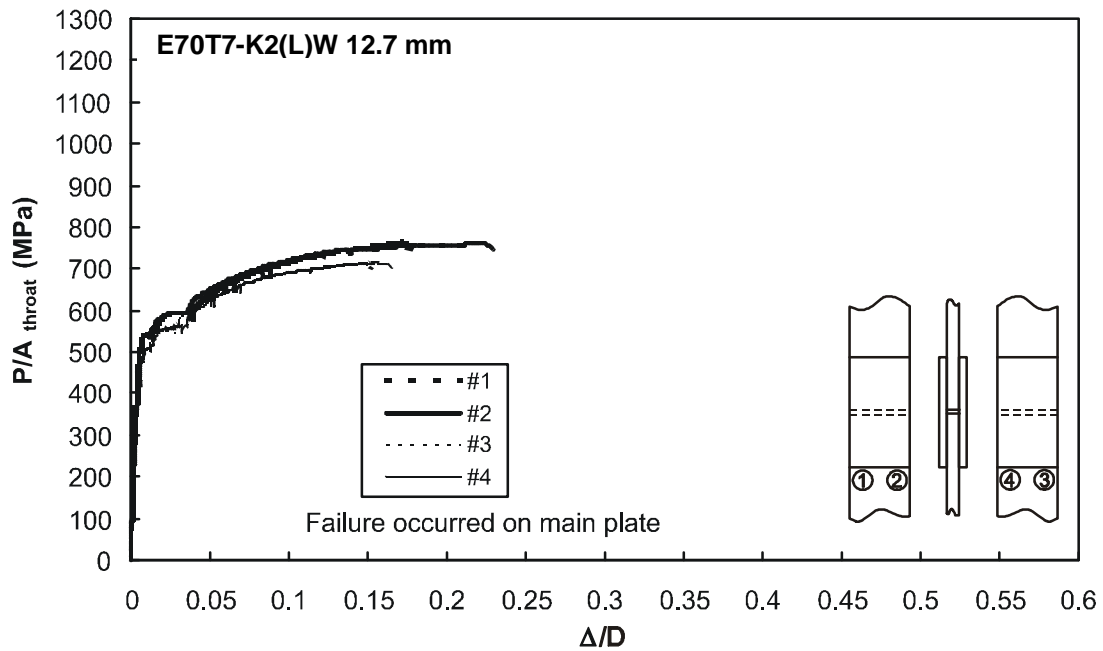

Figure F86 – Specimen T29-2 with 12.7 mm weld from E70T7-K2 electrode

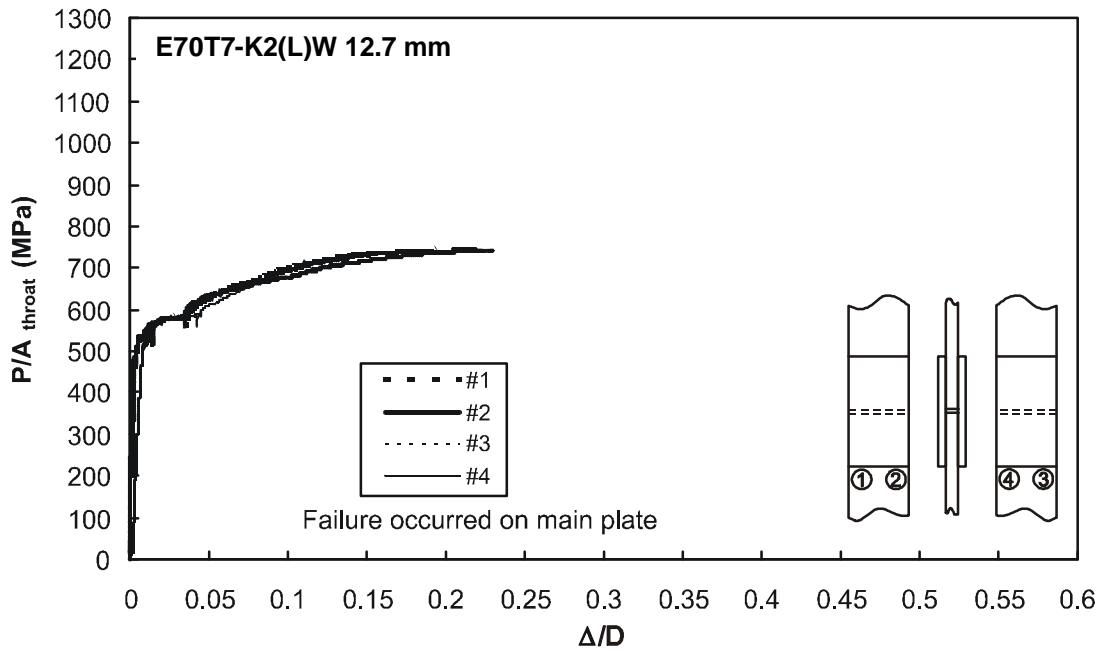

Figure F87 – Specimen T29-3 with 12.7 mm weld from E70T7-K2 electrode

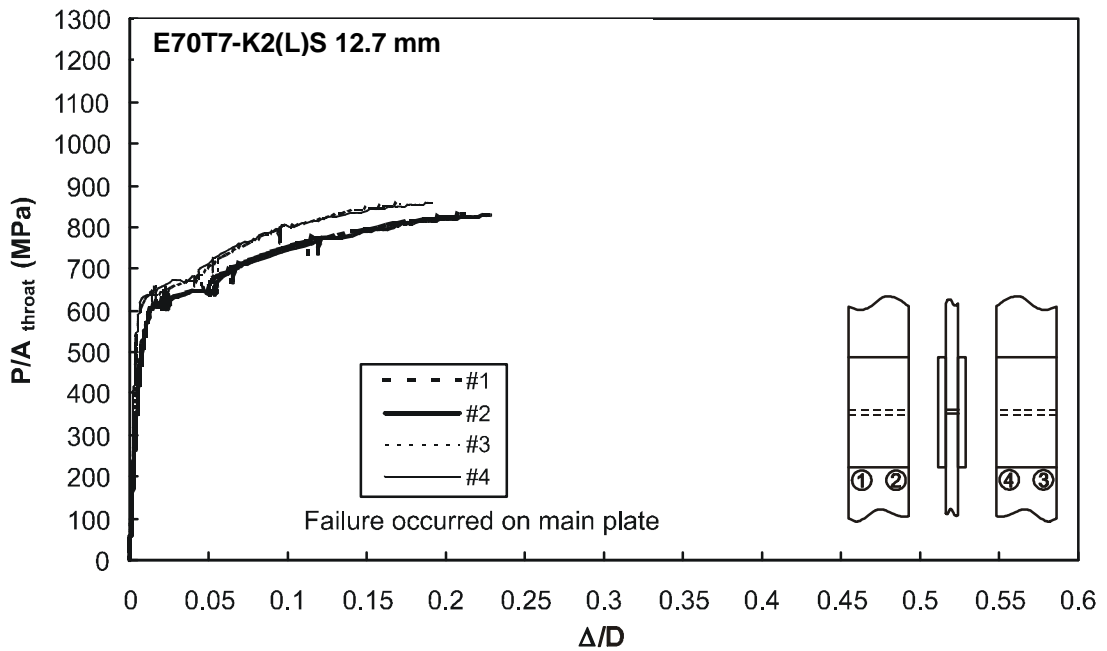

Figure F88 – Specimen T30-1 with 12.7 mm weld from E70T7-K2 electrode

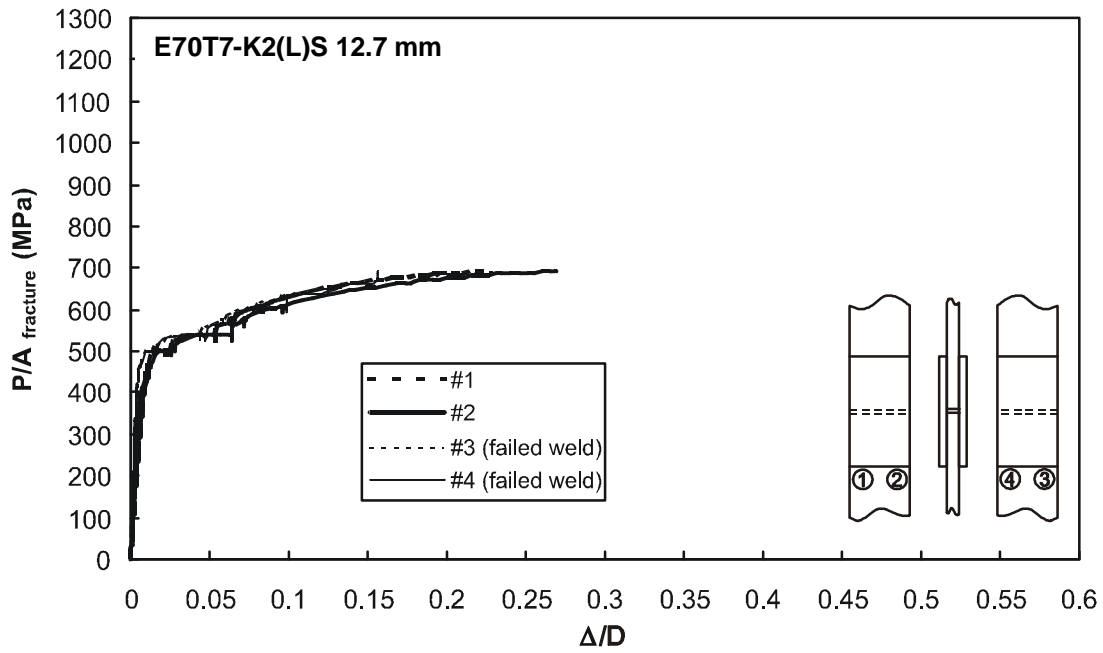

Figure F89 – Specimen T30-2 with 12.7 mm weld from E70T7-K2 electrode

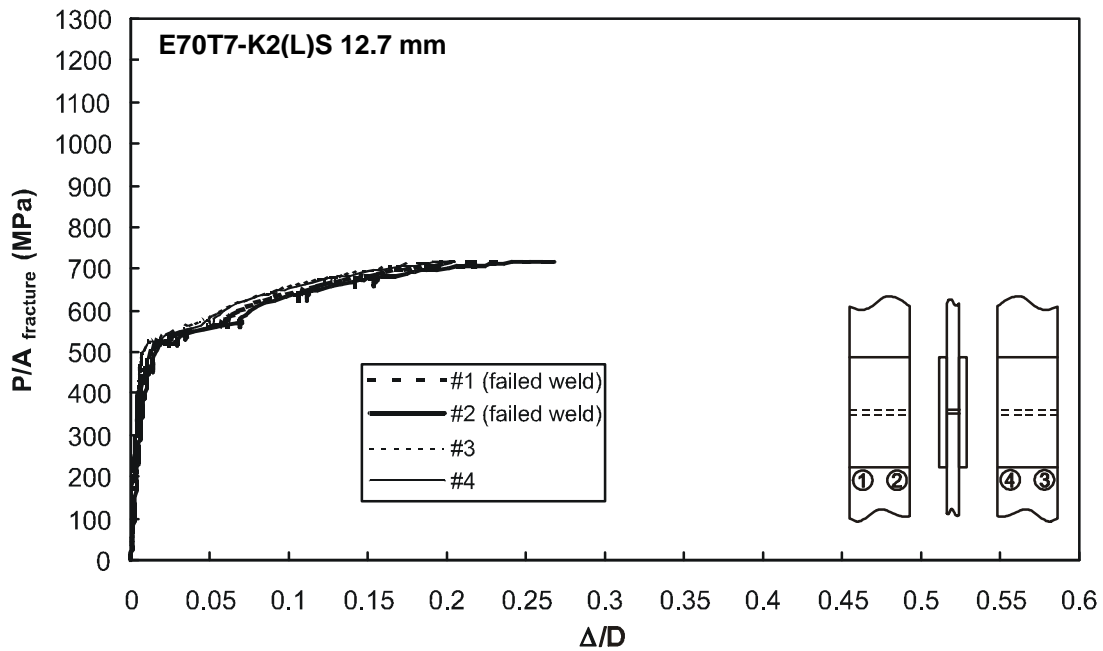

Figure F90 – Specimen T30-3 with 12.7 mm weld from E70T7-K2 electrode

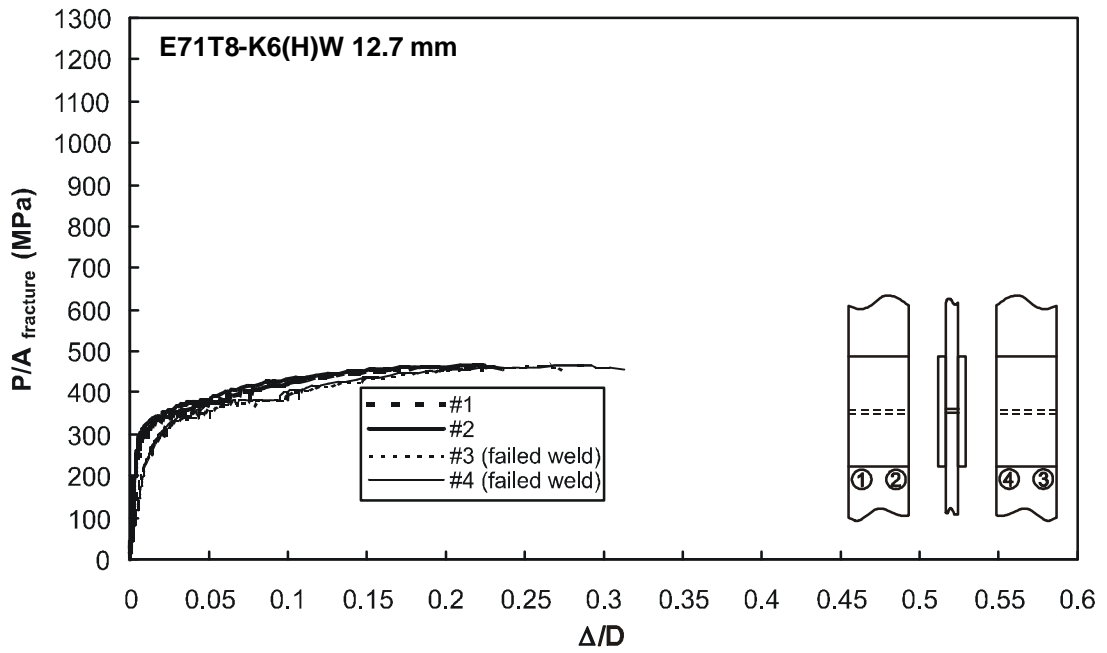

Figure F91 – Specimen T31-1 with 12.7 mm weld from E71T8-K6 electrode

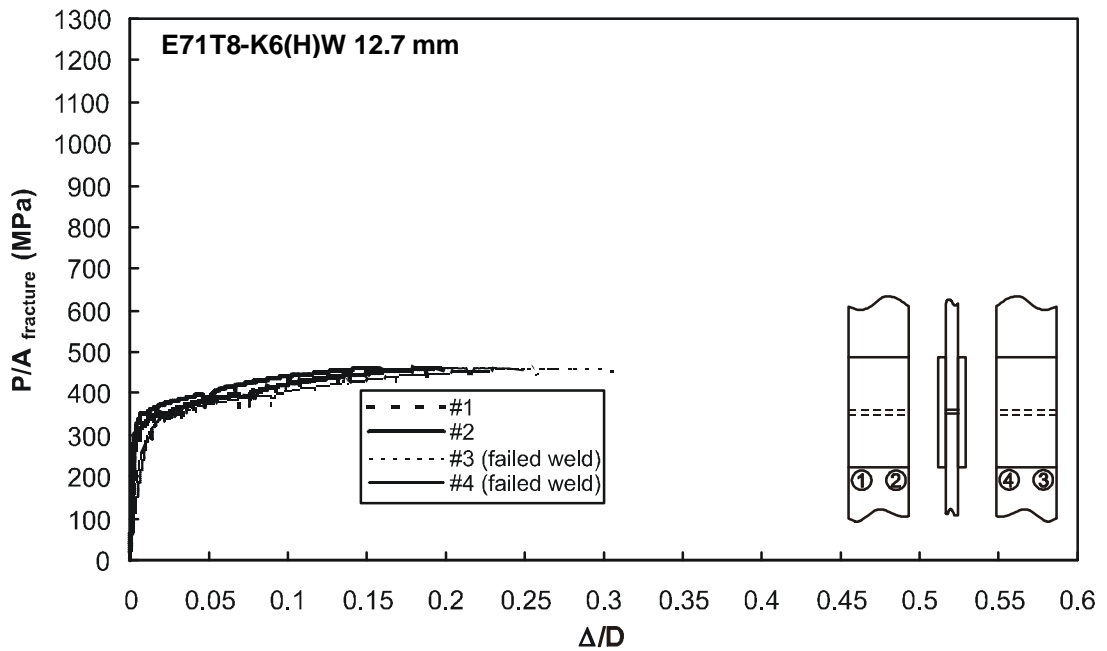

Figure F92 – Specimen T31-2 with 12.7 mm weld from E71T8-K6 electrode

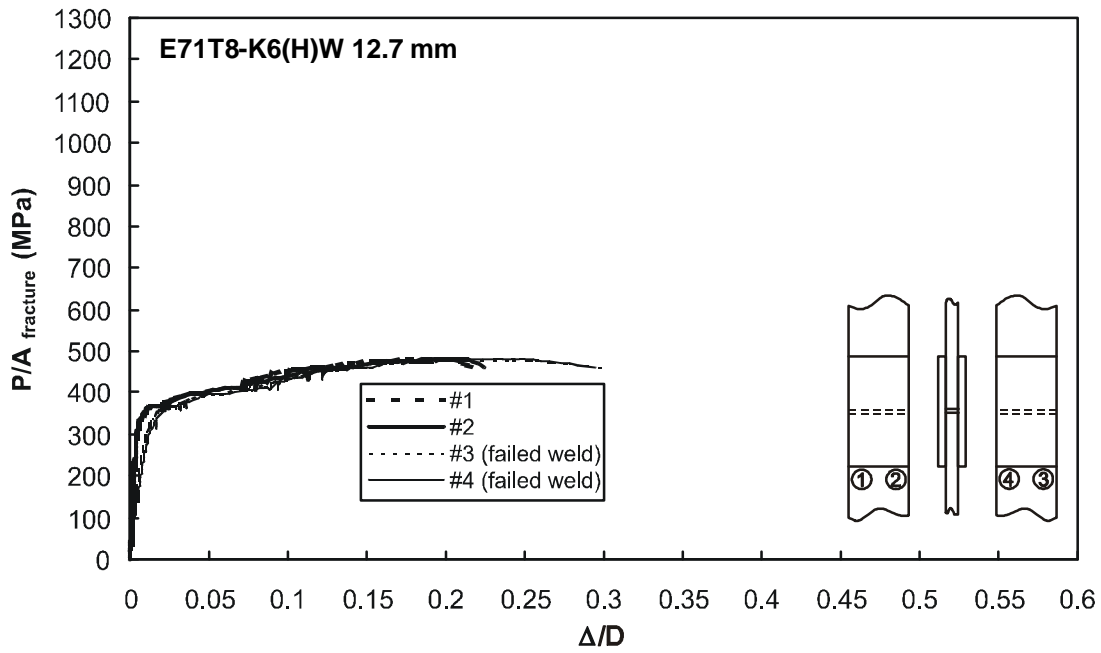

Figure F93 – Specimen T31-3 with 12.7 mm weld from E71T8-K6 electrode

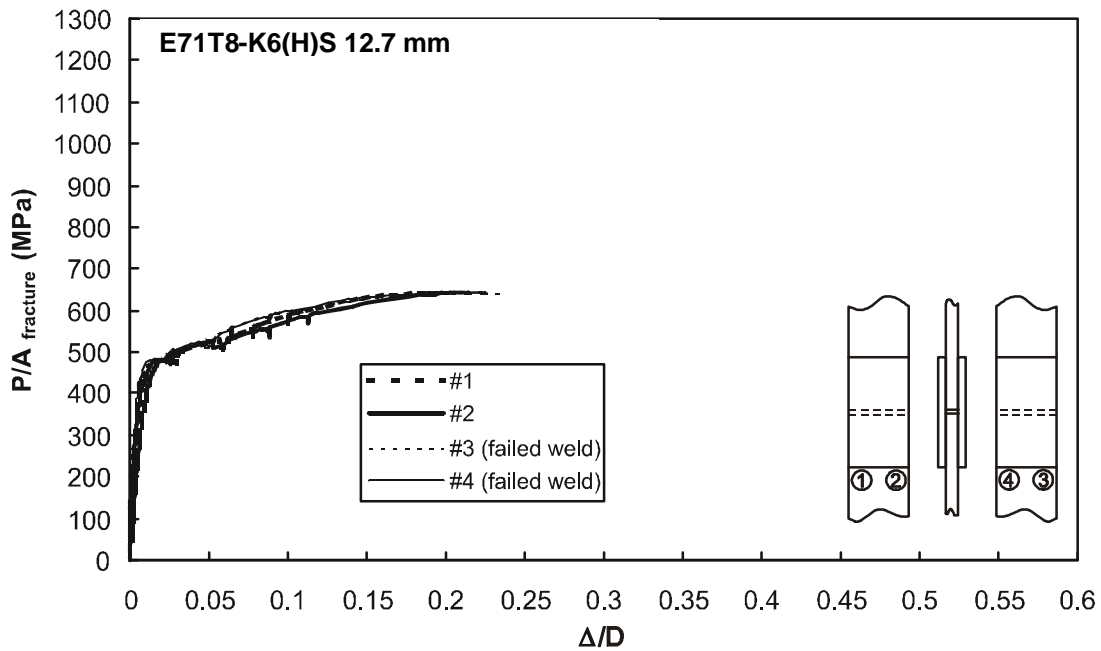

Figure F94 – Specimen T32-1 with 12.7 mm weld from E71T8-K6 electrode

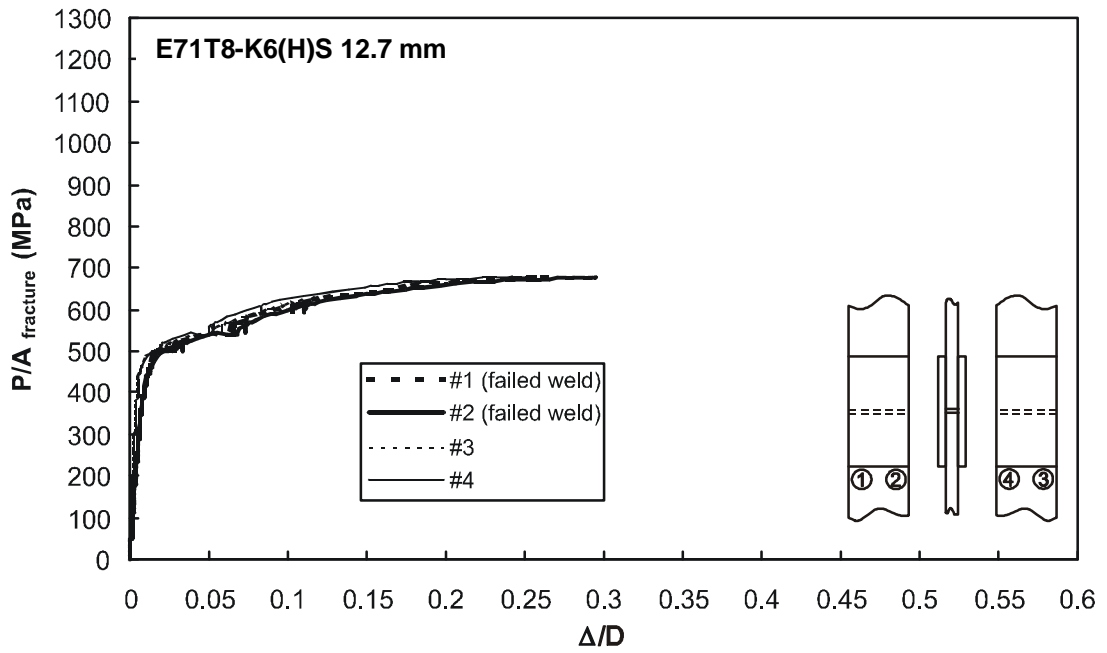

Figure F95 – Specimen T32-2 with 12.7 mm weld from E71T8-K6 electrode

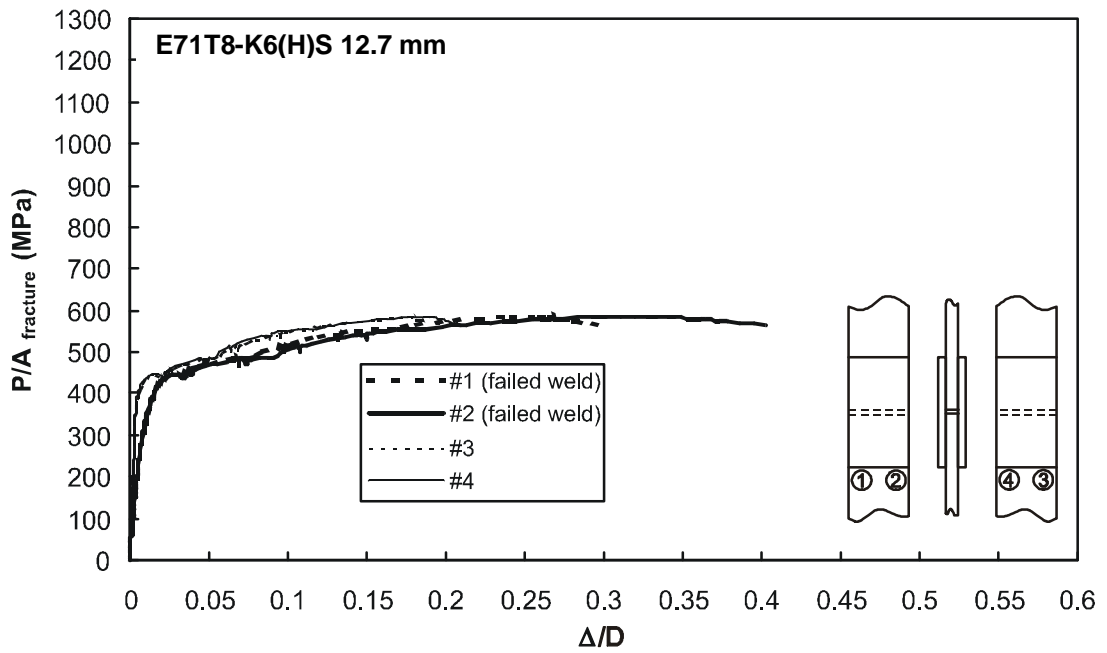

Figure F96 – Specimen T32-3 with 12.7 mm weld from E71T8-K6 electrode

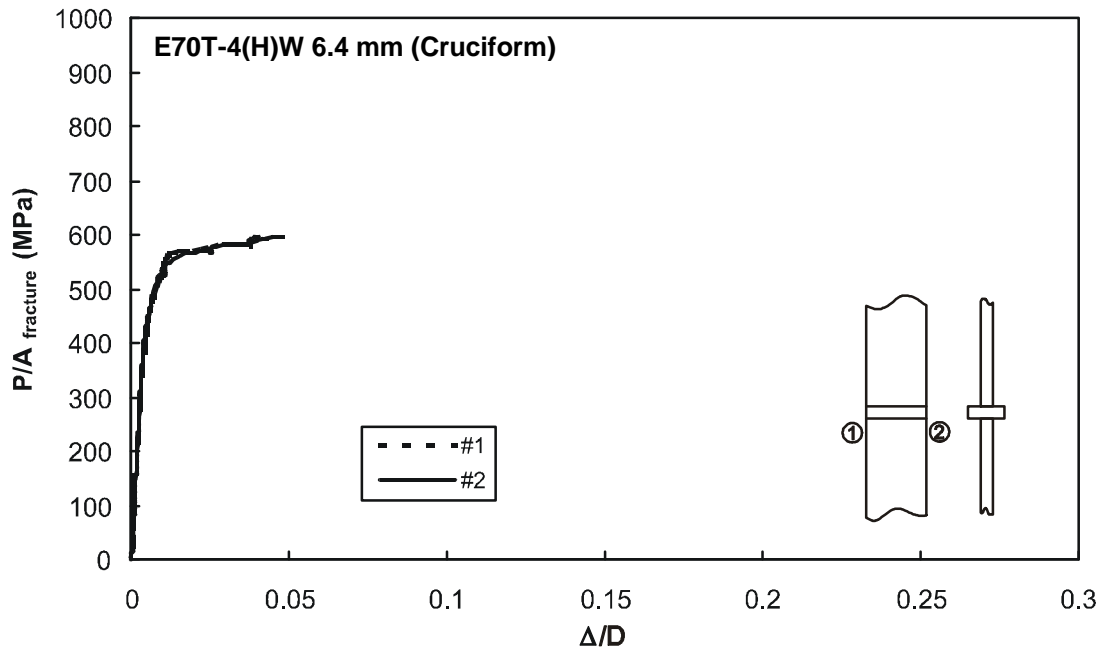

Figure F97 – Specimen C1-1 with 6.4 mm weld from E70T-4 electrode

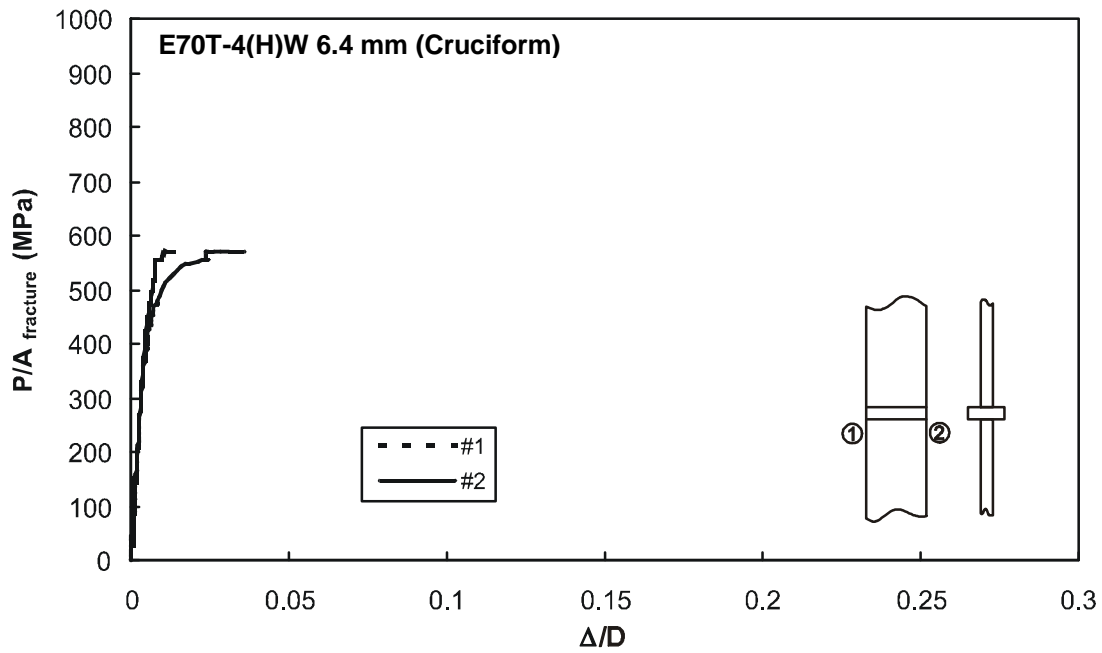

Figure F98 – Specimen C1-2 with 6.4 mm weld from E70T-4 electrode

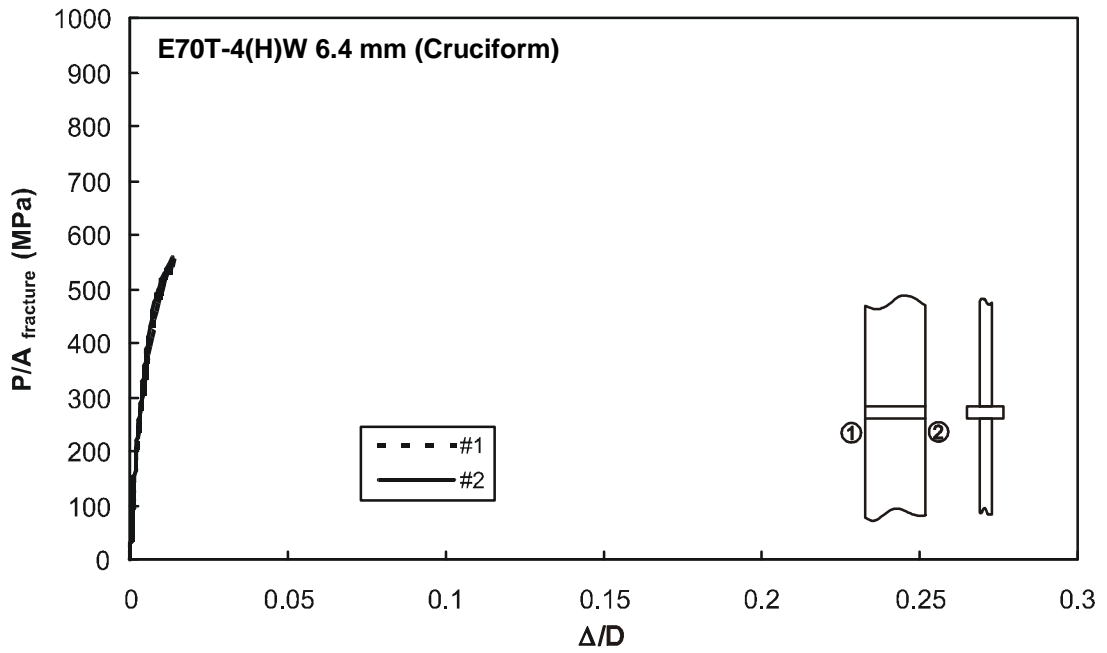

Figure F99 – Specimen C1-3 with 6.4 mm weld from E70T-4 electrode

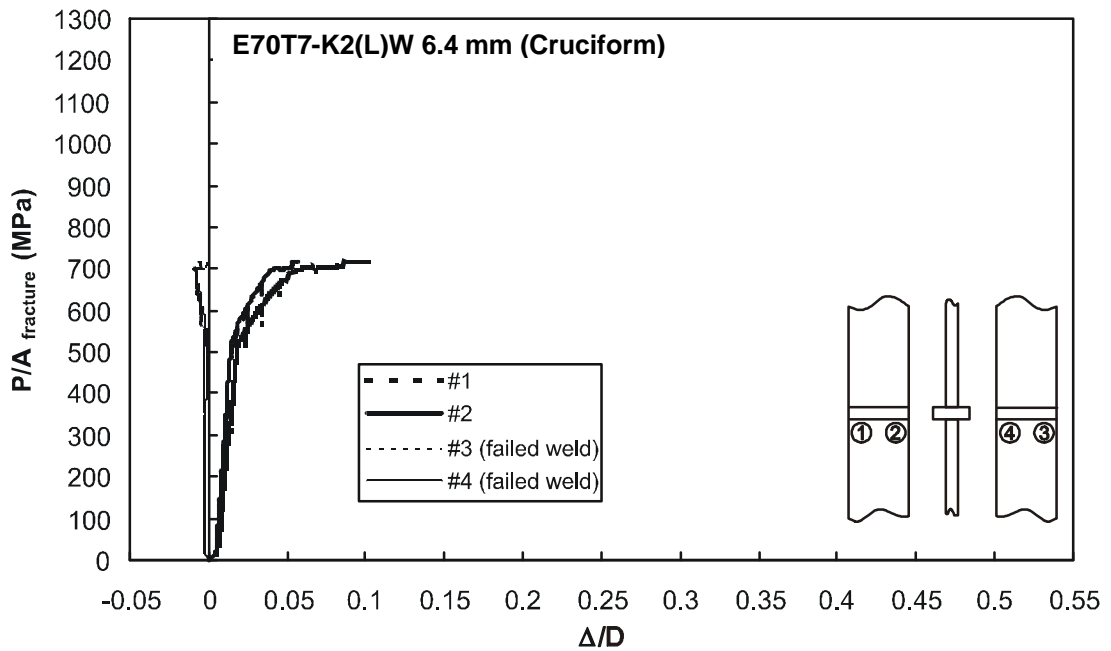

Figure F100 – Specimen C2-1 with 6.4 mm weld from E70T7-K2 electrode

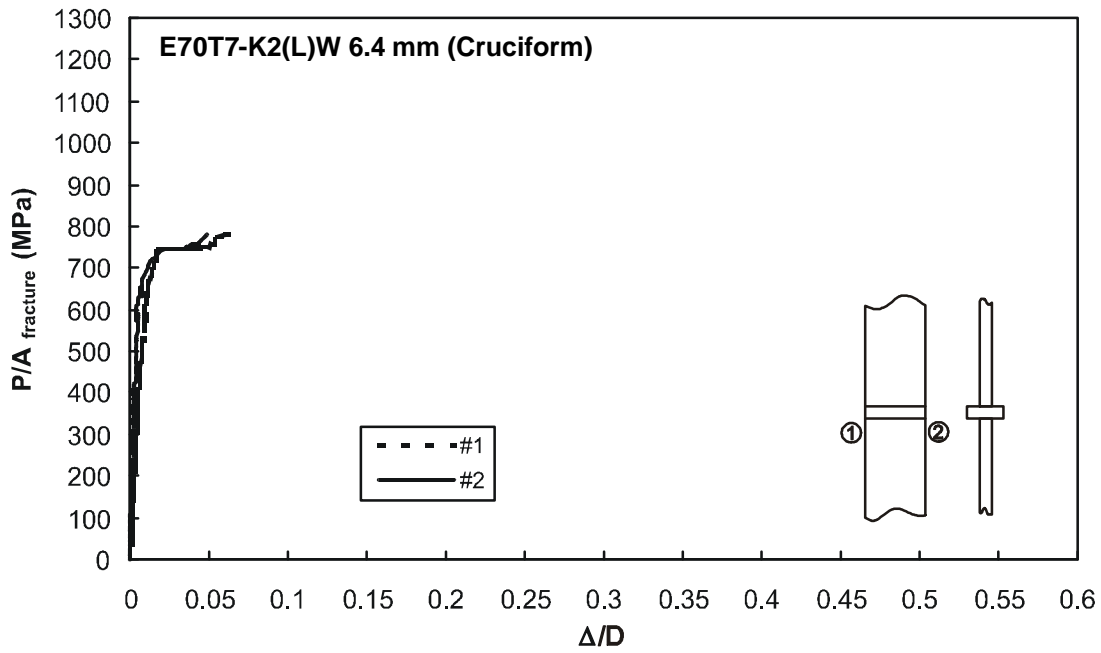

Figure F101 – Specimen C2-2 with 6.4 mm weld from E70T7-K2 electrode

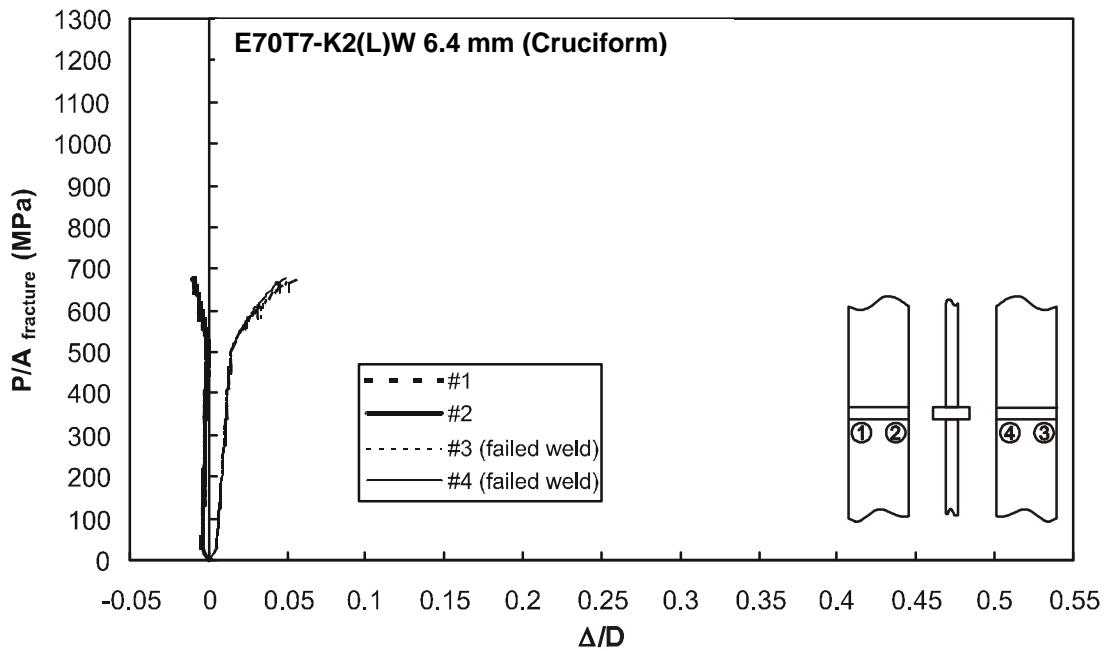

Figure F102 – Specimen C2-3 with 6.4 mm weld from E70T7-K2 electrode

Appendix G
Weld Hardness Test Results

Table G1 – All-Weld Specimen Rockwell B Scale Hardness Test Results

Filler Metal Classification	Electrode Manufacturer	Steel Fabricator	Rockwell B Scale Hardness												Standard Deviation	Coefficient of Variation	Tensile Strength from Weld Metal Tension Coupon (MPa)			
			1	2	3	4	5	6	7	8	9	10	11	12				Mean		
E7014	L	W	62	62	54	63	63	63	63	63	58	58	59	62	63	63	60	2.19	0.04	520
E70T-4	H	W	57	59	58	56	57	60	55	50	55	50	55	56	—	—	56	2.84	0.05	513
	H	S	66	65	60	63	66	65	65	65	65	65	65	65	65	64	64	0.38	0.01	631
E70T-7	L	W	62	62	61	63	63	63	63	57	61	61	60	61	60	61	59	1.60	0.03	562
	H	W	60	65	62	60	64	63	60	65	63	60	65	63	62	63	60	1.91	0.03	605
E70T7-K2	L	S	60	64	58	63	65	63	61	64	62	64	64	61	62	61	1.59	0.03	652	
E71T8-K6	L	W	65	66	63	67	68	65	65	67	65	65	67	65	67	63	65	1.41	0.02	592
	H	W	56	56	58	60	61	57	55	52	56	54	56	54	56	54	56	1.51	0.03	490
E71T8-K6	H	S	62	61	57	57	60	58	53	57	58	63	65	61	61	59	4.44	0.08	493	

Table G2 – All-Weld Specimen Rockwell C Scale Hardness Test Results

Filler Metal Classification	Electrode Manufacturer	Steel Fabricator	Rockwell C Scale Hardness												Standard Deviation	Coefficient of Variation	Tensile Strength from Weld Metal Tension Coupon (MPa)		
			1	2	3	4	5	6	7	8	9	10	11	12				Mean	
E7014	L	W	5	4	1	3	2	4	3	3	4	3	3	3	3	3	1.47	0.46	520
E70T-4	H	W	3	4	4	4	2	—	4	4	2	—	3	3	3	3	0.89	0.26	513
	H	S	15	13	10	16	16	17	16	16	16	17	15	15	15	15	2.59	0.18	631
E70T-7	L	W	7	10	8	10	8	10	8	10	8	10	9	9	9	9	1.33	0.15	562
	H	W	10	9	15	12	9	8	12	12	9	8	11	11	11	11	2.59	0.25	605
E70T7-K2	L	S	13	14	15	14	13	13	14	14	13	13	14	14	14	14	0.82	0.06	652
	L	W	13	13	13	11	11	11	11	11	11	11	13	12	12	12	1.03	0.08	592
E71T8-K6	L	W	9	10	9	11	6	12	10	11	6	12	10	10	10	10	2.07	0.22	584
	H	W	2	6	4	4	3	2	4	4	3	2	4	4	4	4	1.52	0.43	490
E71T8-K6	H	S	3	4	3	2	1	—	3	2	1	—	3	3	3	3	1.14	0.44	493

Table G3 – Lapped Splice Specimen Rockwell B Scale Hardness Test Results

Specimen Designation	Size (mm)	Identifier	Rockwell B Scale Hardness												Standard Deviation	Coefficient of Variation	Ultimate P/A _{throat} (MPa)	Ultimate P/A _{fracture} (MPa)		
			1	2	3	4	5	6	7	8	9	10	11	12					Mean	
T2-1	6.4	E7014(L)W	53	67	63	65	60	67	—	—	—	—	—	—	—	62	5.23	0.08	735	720
T16-1		E70T7-K2(L)W	67	70	69	69	74	74	—	—	—	—	—	—	—	70	2.89	0.04	936	699
T18-1		E71T8-K6(H)W	69	63	70	67	68	69	—	—	—	—	—	—	—	68	2.68	0.04	1110	490
T19-1		E71T8-K6(H)S	63	63	68	71	70	71	—	—	—	—	—	—	—	68	3.82	0.06	1003	810
T19-2		E71T8-K6(H)S	68	70	72	62	64	68	65	71	72	—	—	—	—	68	3.73	0.06	901	810
T20-2		E7014(L)W	65	65	64	63	65	63	64	61	66	62	65	—	—	64	1.48	0.02	681	456
T21-2	12.7	E70T-4(H)W	67	65	63	63	64	65	66	67	66	67	67	65	65	1.51	0.02	712	431	
T22-1		E70T-4(H)S	67	70	70	70	69	67	66	72	71	72	71	69	69	1.91	0.03	848	491	
T23-2		E70T-4(L)W	64	65	66	65	66	68	66	65	64	67	64	62	65	1.66	0.03	679	495	
T24-2		E70T-4(L)S	68	68	67	67	70	71	70	69	68	67	—	—	68	1.46	0.02	810	679	
T26-2		E70T-7(H)S	66	70	69	70	67	70	63	68	68	68	70	—	68	2.14	0.03	821	868	
T28-2		E70T-7(L)S	68	69	69	68	69	70	72	71	69	70	69	71	69	1.24	0.02	810	441	
T31-2	E71T8-K6(H)W	62	64	64	65	64	65	66	61	67	58	66	67	64	2.68	0.04	822	460		
T32-1		E71T8-K6(H)S	64	65	63	62	65	66	63	66	69	68	61	68	65	2.41	0.04	779	644	

Note: Hardness results obtained after tension testing.

Table G4 – Lapped Splice Specimen Rockwell C Scale Hardness Test Results

Specimen Designation	Size (mm)	Identifier	Measurement End	Rockwell C Scale Hardness								Standard Deviation	Coefficient of Variation	Ultimate P/A _{throat} (MPa)	Ultimate P/A _{fracture} (MPa)	
				1	2	3	4	5	6	Mean						
T2-1		E7014(L)W	Front End 1	5	16	15	—	—	—	—	—	13	4.17	735	720	
			Front End 2	12	16	13	—	—	—	—	—	—	—	—	—	
			Back End 1	13	14	18	14	—	—	—	—	—	14	1.70	678	—
			Back End 2	13	14	14	—	—	—	—	—	—	—	—	—	—
T5-3	6.4	E70T-4(H)W	Front End 1*	36	38	40	35	39	38	38	38	38	1.67	970	—	
			Front End 2*	37	40	37	40	38	—	—	—	—	—	—	—	
			Back End 1*	38	41	42	40	42	40	38	37	38	3.46	993	439	
			Back End 2*	31	36	36	33	38	37	—	—	—	—	—	—	—
			Front End 1	36	39	39	37	—	—	—	—	—	—	—	—	—
			Front End 2	35	37	38	38	—	—	—	—	—	—	—	—	—
			Back End 1	36	37	38	37	39	38	38	37	38	1.01	993	439	
			Back End 2	37	39	37	38	—	—	—	—	—	—	—	—	—
T7-1		E70T-4(H)S	Front End 1*	37	35	29	34	—	—	—	—	35	3.23	1209	—	
			Front End 2*	32	37	39	35	40	35	39	36	39	3.96	1112	788	
			Back End 1*	33	38	42	34	40	40	45	40	40	—	—	—	
			Back End 2*	37	43	45	40	45	40	—	—	—	—	—	—	
			Front End 1	37	36	34	36	—	—	—	—	—	36	1.25	1209	—
			Front End 2	37	36	35	38	—	—	—	—	—	—	—	—	—
			Back End 1	36	35	32	39	36	36	39	36	36	3.81	1112	788	
			Back End 2	43	41	40	43	—	—	—	—	—	—	—	—	—

* Hardness test results obtained before tension testing.

Table G4 – Lapped Splice Specimen Rockwell C Scale Hardness Test Results (Cont.)

Specimen Designation	Size (mm)	Identifier	Measurement End	Rockwell C Scale Hardness							Standard Deviation	Coefficient of Variation	Ultimate P/A _{throat} (MPa)	Ultimate P/A _{fracture} (MPa)
				1	2	3	4	5	6	Mean				
T8-2		E70T-4(L)W	Front End 1*	19	21	22	21	22	19	19	3.54	0.19	956	—
			Front End 2*	12	19	20	12	20	—	19				
			Back End 1*	27	29	29	25	28	28	26				
			Back End 2*	24	26	24	23	27	23	26				
			Front End 1	32	34	33	35	34	—	33				
			Front End 2	29	33	34	32	34	33	33				
T9-1	6.4	E70T-4(L)S	Back End 1	24	20	18	24	17	23	19	4.07	0.22	930	588
			Back End 2	10	17	19	16	19	—	19				
			Front End 1*	13	20	20	19	—	—	20				
			Front End 2*	18	22	23	20	21	—	20				
			Back End 1*	6	23	21	27	23	—	20				
			Back End 2*	14	20	23	20	23	21	20				
T11-1		E70T-7(H)W	Front End 1	23	25	25	25	—	—	24	1.85	0.08	1135	—
			Front End 2	22	22	27	26	—	—	24				
			Back End 1	24	27	28	25	25	23	26				
			Back End 2	26	26	26	29	30	27	26				
			Front End 1	25	26	32	30	30	30	27				
			Front End 2	24	25	27	25	26	25	27				
T11-1		E70T-7(H)W	Back End 1	25	30	31	29	32	32	29	2.50	0.09	898	—
			Back End 2	25	26	27	28	29	30	29				

* Hardness test results obtained before tension testing.

Table G4 – Lapped Splice Specimen Rockwell C Scale Hardness Test Results (Cont.)

Specimen Designation	Size (mm)	Identifier	Measurement End	Rockwell C Scale Hardness								Standard Deviation	Coefficient of Variation	Ultimate P/A _{throat} (MPa)	Ultimate P/A _{fracture} (MPa)
				1	2	3	4	5	6	Mean					
T12-2		E70T-7(H)S	Front End 1*	16	28	30	26	31	31	28	28	4.61	0.17	1066	—
			Front End 2*	24	31	31	26	33	27	30	30	3.15	0.10	1188	976
			Back End 1*	31	30	32	29	34	34	31	32	1.50	0.05	1066	—
			Back End 2*	23	29	30	26	32	31	32	31	2.99	0.09	1188	976
			Front End 1	31	30	29	31	33	34	33	33	3.45	0.12	1000	—
			Front End 2	32	31	33	34	33	—	—	—	4.85	0.22	957	572
T13-3	6.4	E70T-7(L)W	Back End 1	28	31	32	30	—	—	—	32	2.99	0.09	1188	976
			Back End 2	36	35	35	—	—	—	—	28	3.45	0.12	957	572
			Front End 1*	22	26	30	24	28	26	28	26	2.99	0.09	1188	976
			Front End 2*	27	31	31	30	34	31	30	31	3.45	0.12	957	572
			Back End 1*	22	25	27	24	28	24	28	24	4.85	0.22	1000	—
			Back End 2*	12	21	23	14	22	18	22	18	2.99	0.09	1188	976
T14-1		E70T-7(L)S	Front End 1	32	32	32	30	—	—	—	30	2.13	0.07	957	572
			Front End 2	28	27	28	28	—	—	—	25	2.77	0.11	1000	—
			Back End 1	23	28	26	28	28	—	—	25	2.39	0.10	970	—
			Back End 2	21	23	24	22	—	—	—	25	2.35	0.09	936	533
			Front End 1*	20	26	27	25	27	24	27	24	2.39	0.10	970	—
			Front End 2*	22	26	27	23	28	26	28	26	2.35	0.09	936	533
T14-1		E70T-7(L)S	Back End 1*	20	23	25	26	27	25	27	25	2.35	0.09	936	533
			Back End 2*	22	25	27	24	27	28	27	28	2.32	0.08	970	—
			Front End 1	23	26	27	27	28	26	28	26	2.04	0.07	936	533
			Front End 2	26	28	30	31	27	31	27	31	2.04	0.07	936	533
			Back End 1	26	29	32	28	31	30	31	30	2.04	0.07	936	533
			Back End 2	25	29	28	30	31	29	31	29	2.04	0.07	936	533

* Hardness test results obtained before tension testing.

Table G4 – Lapped Splice Specimen Rockwell C Scale Hardness Test Results (Cont.)

Specimen Designation	Size (mm)	Identifier	Measurement End	Rockwell C Scale Hardness								Standard Deviation	Coefficient of Variation	Ultimate P/A _{throat} (MPa)	Ultimate P/A _{fracture} (MPa)
				1	2	3	4	5	6	Mean					
T16-1		E70T7-K2(L)W	Front End 1	23	25	22	27	—	—	—	24	1.71	0.07	1034	—
			Front End 2	22	24	24	26	26	25						
			Back End 1	19	19	21	21	18	20						
			Back End 2	16	18	21	22	20	—						
T17-1	6.4	E70T7-K2(L)S	Front End 1*	22	28	29	28	30	30	29	29	3.11	0.11	1158	947
			Front End 2*	26	33	31	33	30	32						
			Back End 1*	24	27	25	27	26	27						
			Back End 2*	27	28	25	28	26	—						
			Front End 1	30	30	28	22	—	—						
			Front End 2	25	25	24	—	—	—						
			Back End 1	22	27	27	—	—	—						
			Back End 2	27	25	27	29	—	—						
T18-1		E71T8-K6(H)W	Front End 1	19	23	23	—	—	—	—	23	2.99	0.13	1110	490
			Front End 2	18	24	25	26	—	—						
			Back End 1	19	21	21	—	—	—						
			Back End 2	16	17	18	—	—	—						

* Hardness test results obtained before tension testing.

Table G4 – Lapped Splice Specimen Rockwell C Scale Hardness Test Results (Cont.)

Specimen Designation	Size (mm)	Identifier	Measurement End	Rockwell C Scale Hardness								Standard Deviation	Coefficient of Variation	Ultimate P/A _{throat} (Mpa)	Ultimate P/A _{fracture} (Mpa)	
				1	2	3	4	5	6	Mean						
T19-1	6.4	E71T8-K6(H)S	Front End 1*	16	19	19	17	19	17	18	17	2.14	0.13	975	—	
			Front End 2*	12	16	18	14	17	16	17	16	16	2.88	0.20	1003	810
			Back End 1*	8	15	15	15	18	12	14	14	14	2.33	0.12	975	—
			Back End 2*	13	16	13	18	16	—	—	—	—	1.92	0.11	1003	810
			Front End 1	20	22	24	—	—	—	—	—	—	1.21	0.07	901	810
			Front End 2	16	19	18	21	21	21	18	20	20	1.68	0.09	1070	—
T19-2	6.4	E71T8-K6(H)S	Front End 1*	18	18	16	19	17	19	17	18	1.21	0.07	901	810	
			Front End 2*	16	18	19	18	19	16	18	16	2.15	0.11	901	810	
			Back End 1*	16	20	19	19	21	18	18	18	2.55	0.13	1070	—	
			Back End 2*	15	18	19	18	20	18	18	18	2.38	0.16	681	456	
			Front End 1	17	19	18	18	19	—	—	—	2.64	0.17	633	—	
			Front End 2	21	22	23	22	—	—	—	—	2.26	0.13	704	—	
T20-2	12.7	E7014(L)W	Back End 1	19	21	19	18	16	16	21	20	1.98	0.14	712	431	
			Back End 2	17	20	21	18	23	25	15	15	1.98	0.14	712	431	
			Front End 1	15	12	14	16	18	20	15	15	1.98	0.14	712	431	
			Front End 2	13	13	14	14	17	17	16	16	1.98	0.14	712	431	
T21-2	12.7	E70T-4(H)W	Back End 1	13	15	13	19	18	19	19	16	2.26	0.13	704	—	
			Back End 2	11	14	14	16	17	18	17	17	2.26	0.13	704	—	
			Front End 1	15	19	20	15	20	19	17	17	1.98	0.14	712	431	
			Front End 2	13	19	16	16	18	17	14	14	1.98	0.14	712	431	

* Hardness test results obtained before tension testing.

Table G4 – Lapped Splice Specimen Rockwell C Scale Hardness Test Results (Cont.)

Specimen Designation	Size (mm)	Identifier	Measurement End	Rockwell C Scale Hardness							Standard Deviation	Coefficient of Variation	Ultimate P/A _{throat} (MPa)	Ultimate P/A _{fracture} (MPa)
				1	2	3	4	5	6	Mean				
T22-1		E70T-4(H)S	Front End 1	16	21	22	20	23	23	22	2.19	0.10	848	491
			Front End 2	20	22	23	23	24	23	22				
T23-2		E70T-4(L)W	Back End 1	16	19	22	19	21	19	20	1.95	0.10	739	—
			Back End 2	18	21	22	20	23	20	20				
T24-2		E70T-4(L)W	Front End 1	14	16	17	17	20	18	16	1.96	0.12	679	495
			Front End 2	13	15	14	17	17	17	17				
T25-1	12.7	E70T-4(L)S	Back End 1	14	18	18	16	19	19	17	1.98	0.11	648	—
			Back End 2	14	18	18	16	19	20	20				
T26-2		E70T-7(H)S	Front End 1	17	20	20	19	20	20	19	1.42	0.08	830	—
			Front End 2	18	19	20	16	19	17	19				
T27-3		E70T-7(L)W	Back End 1	24	26	23	27	20	20	21	3.53	0.17	810	679
			Back End 2	16	18	21	16	20	20	20				
T25-1		E70T-7(H)W	Front End 1	17	21	22	23	25	25	22	2.34	0.11	Reinforced Weld Failed	
			Front End 2	20	21	22	23	23	19	19				
T26-2		E70T-7(H)S	Back End 1	20	23	22	24	24	26	23	2.22	0.10	821	868
			Back End 2	20	21	21	22	23	27	27				
T27-3		E70T-7(L)W	Front End 1	15	19	21	18	22	21	19	2.15	0.11	821	868
			Front End 2	17	21	20	19	22	18	18				
T26-2		E70T-7(H)S	Back End 1	17	21	23	19	24	23	22	2.44	0.11	836	—
			Back End 2	20	22	24	20	24	25	25				
T27-3		E70T-7(L)W	Front End 1	15	16	19	17	18	17	17	1.34	0.08	725	—
			Front End 2	15	17	17	18	18	15	15				
T26-2		E70T-7(H)S	Back End 1	14	17	18	19	20	19	18	2.12	0.12	748	630
			Back End 2	15	17	20	18	21	20	20				

Table G4 – Lapped Splice Specimen Rockwell C Scale Hardness Test Results (Cont.)

Specimen Designation	Size (mm)	Identifier	Measurement End	Rockwell C Scale Hardness							Standard Deviation	Coefficient of Variation	Ultimate P/A _{throat} (MPa)	Ultimate P/A _{fracture} (MPa)			
				1	2	3	4	5	6	Mean							
T28-2		E70T-7(L)S	Front End 1	12	19	23	19	23	19	23	19	20	2.94	0.15	788	—	
			Front End 2	20	22	21	20	22	21	20	22	21	20	2.94	0.15		788
			Back End 1	17	22	23	24	25	25	22	25	25	22	2.49	0.11		810
			Back End 2	19	20	21	21	23	24	21	23	24	22	2.49	0.11		810
T29-1		E70T7-K2(L)W	Front End 1	15	18	21	19	22	19	22	22	20	2.42	0.12	Main Plate Failed		
			Front End 2	17	18	20	19	23	22	19	23	22	20	2.42			0.12
			Back End 1	19	22	23	22	24	24	22	24	23	21	2.41			0.11
			Back End 2	16	20	22	22	23	23	22	23	23	21	2.41			0.11
T30-1	12.7	E70T7-K2(L)S	Front End 1	14	18	20	21	22	21	22	22	22	3.42	0.16	Main Plate Failed		
			Front End 2	20	23	26	25	26	22	25	26	22	22	3.42			0.16
			Back End 1	20	21	21	23	23	23	23	23	23	22	1.62			0.07
			Back End 2	19	21	23	22	25	22	22	25	22	22	1.62			0.07
T31-2		E71T8-K6(H)W	Front End 1	20	23	22	18	20	18	20	20	20	2.59	0.13	805	—	
			Front End 2	21	20	19	24	16	16	24	16	16	20	2.59	0.13		805
			Back End 1	8	13	16	12	16	17	12	16	17	15	2.94	0.20		822
			Back End 2	12	14	15	15	17	19	15	17	19	15	2.94	0.20		822
T32-1		E71T8-K6(H)S	Front End 1	14	18	19	20	19	20	19	19	18	1.78	0.10	829	—	
			Front End 2	19	20	19	17	19	16	19	19	16	18	1.78	0.10		829
			Back End 1	13	17	17	21	3	17	21	3	17	15	4.57	0.31		779
			Back End 2	11	15	16	19	14	15	19	14	15	15	4.57	0.31		779

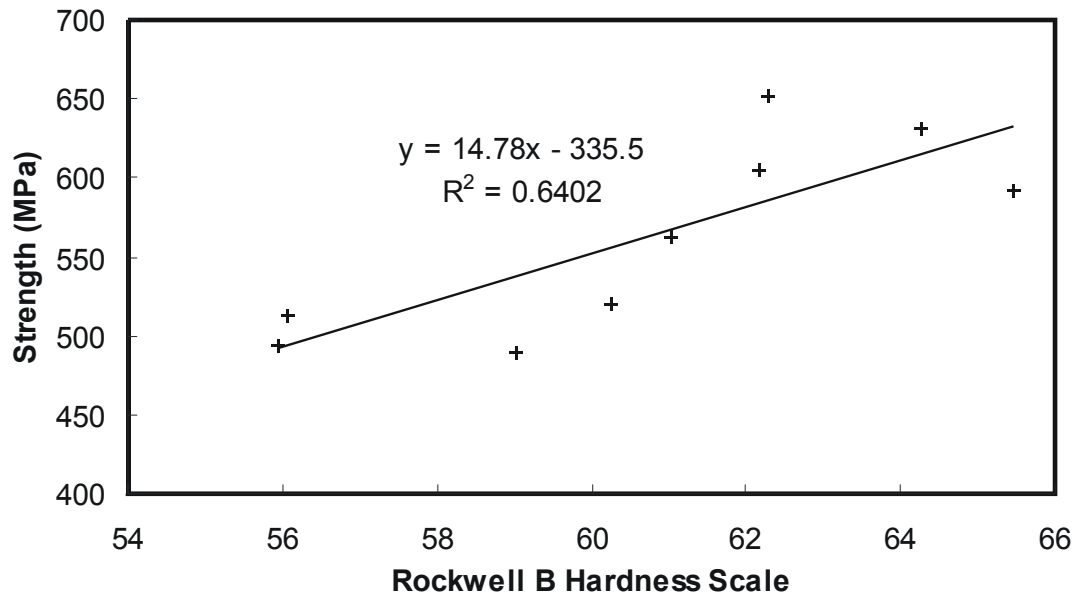

Figure G1 – All-Weld Specimen Hardness (Rockwell B Scale) vs. Weld Metal Tensile Strength

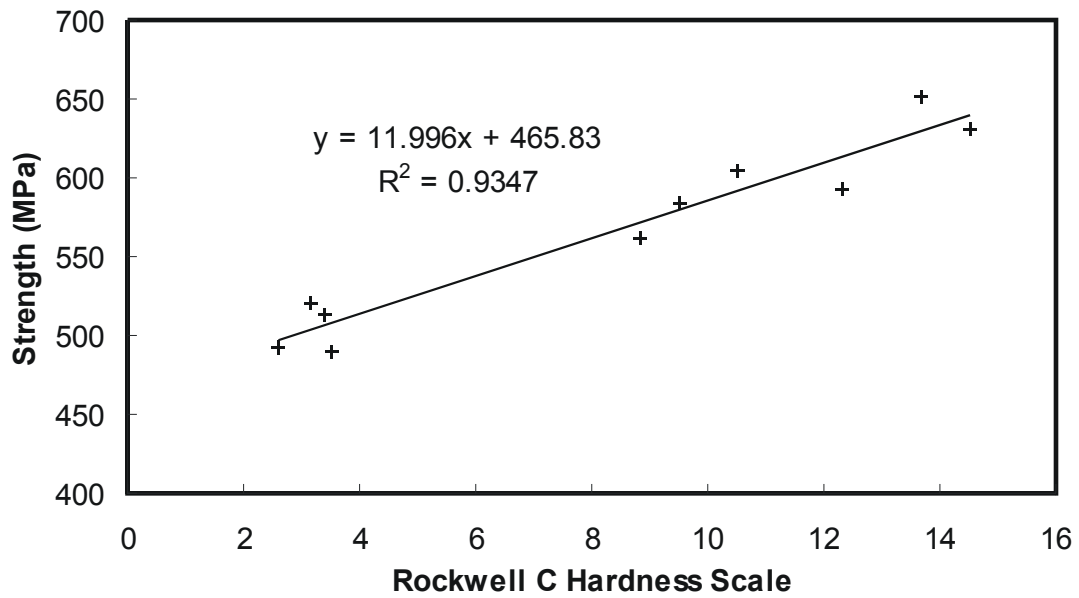

Figure G2 – All-Weld Specimen Hardness (Rockwell C Scale) vs. Weld Metal Tensile Strength

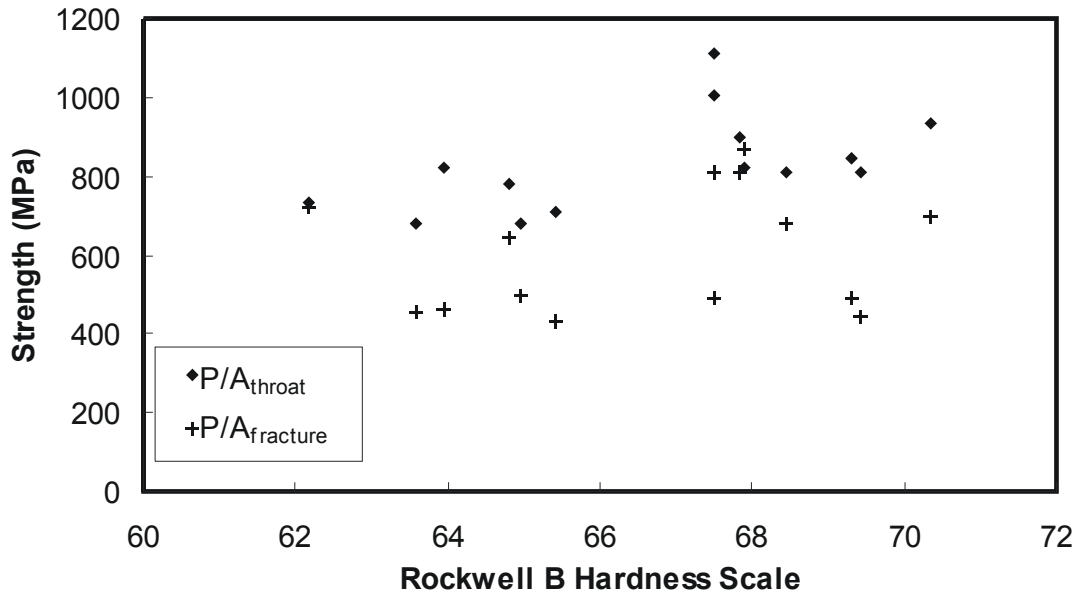

Figure G3 – Fillet Weld Hardness (Rockwell B Scale) After Fracture vs. Weld Strength

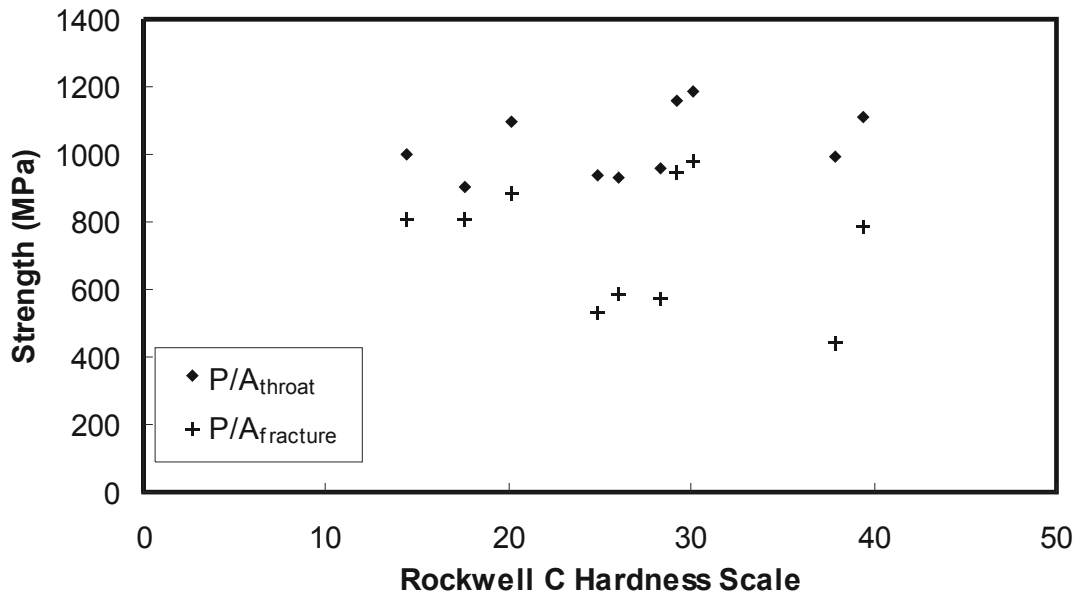

Figure G4 – Fillet Weld Hardness (Rockwell C Scale) Before Fracture vs. Weld Strength

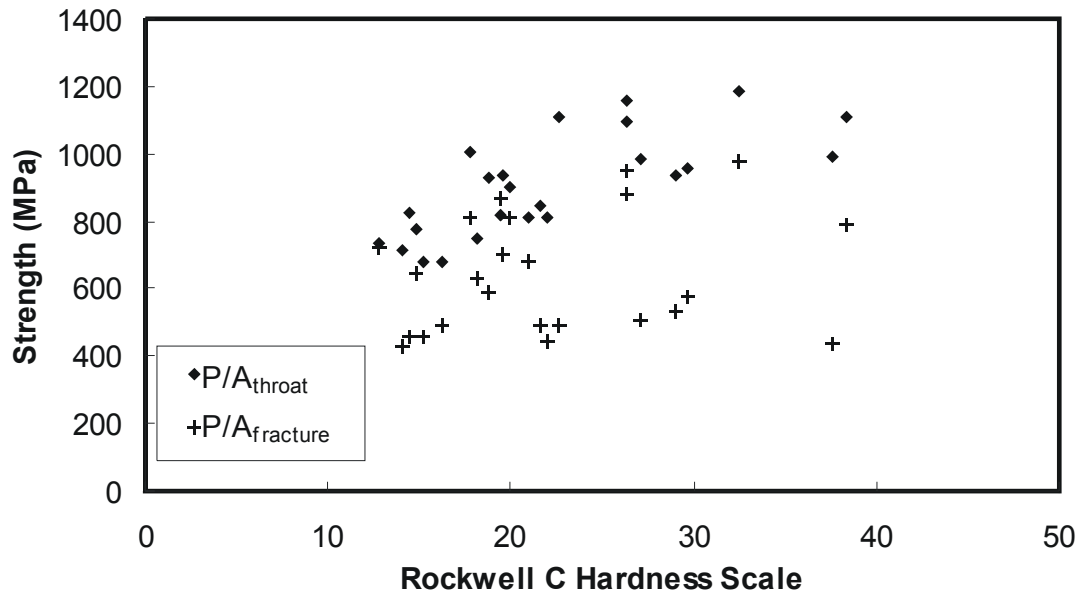

Figure G5 – Fillet Weld Hardness (Rockwell C Scale) After Fracture vs. Weld Strength

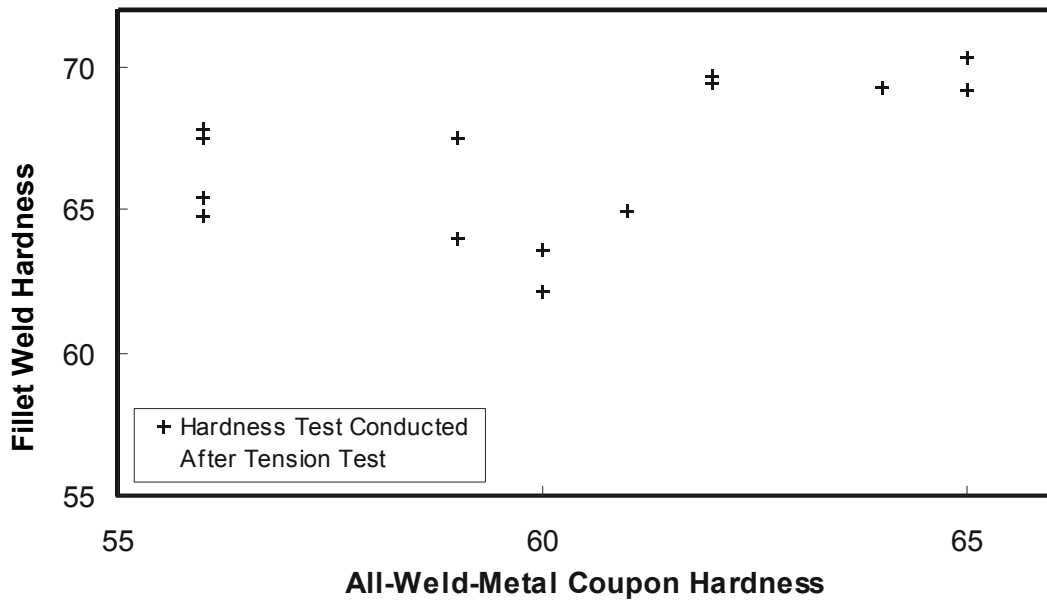

Figure G6 – Fillet Weld Hardness vs. All-Weld-Metal Coupon Hardness (both Rockwell B Scale)

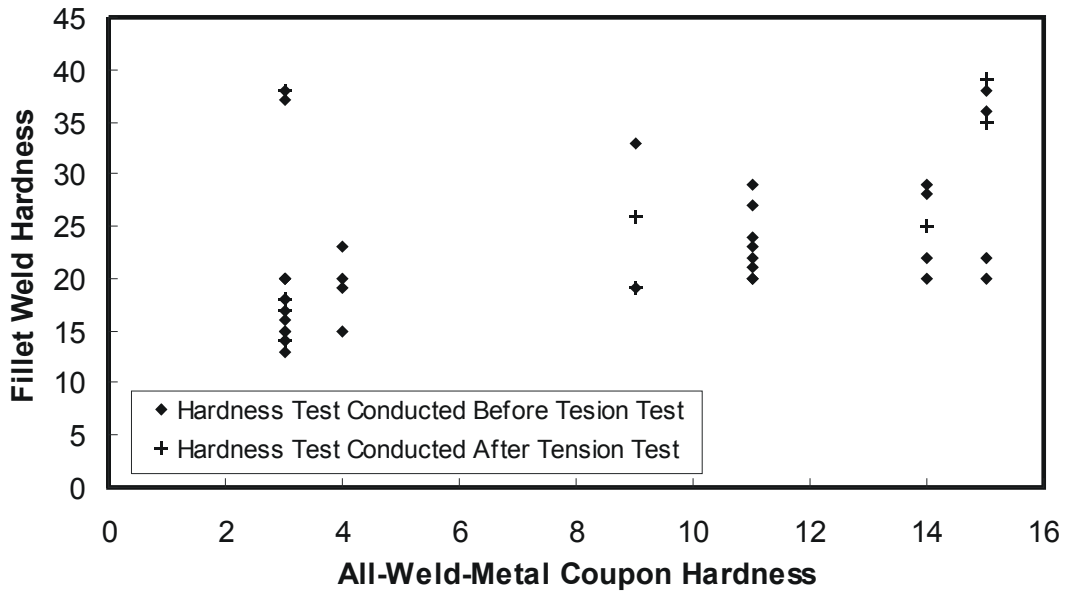

Figure G7 – Fillet Weld Hardness vs. All-Weld-Metal Coupon Hardness (both Rockwell C Scale)

Appendix H

Examination of Fracture Surfaces

Appendix H – Examination of Fracture Surfaces

The fracture surface of representative test specimens was examined under a scanning electron microscope to determine the mode of fracture of welds that failed on the shear plane (angle of failure surface of 0°), on the tension plane (angle of failure surface of 90°), and intermediate fracture surface angles.

Figures H1 and H2 show a typical shear fracture surface in the weld metal from specimen T2-3 (E7014(L)W 6.4 mm) where the fracture angle was 9° . The fracture surface shows elongated microvoids, indicative of ductile shear failure.

Specimen T13-1 (E70T-7(L)W 6.4 mm) failed on a plane at 90° to the load axis. The fracture surface, shown in Figure H3, showed some areas of microvoid coalescence and some areas of cleavage fracture. Figures H4 and H5 show the fracture surface at increased magnification. The equiaxed (rounded) shape of the microvoids indicates failure in tension.

Test specimen T6-2 (E70T-4(H)W 6.4 mm) showed some porosity (see Figure H6). The average angle of the fracture surface for this specimen was 77° . The fracture surface showed some signs of cleavage fracture, as shown in Figure H7, and some microvoid coalescence, as shown in Figure H8. Since the microvoids are equiaxed, the fracture was therefore a tension fracture. Another specimen that failed at a similar angle showed extensive microvoid coalescence on the fracture surface. This was the case for specimen T12-1 (E70T-7(H)S 6.4 mm) shown in Figures H9 and H10, for which the fracture surface was at an angle of 76° .

Specimen T22-2 (E70T-4(H)S 12.7 mm) failed in shear (angle of failure surface of 0°). As expected for this mode of failure, the fracture surface showed elongated microvoids (refer to Figures H11 and H12).

Several test specimens failed on a fracture surface close to 20° . The fracture surface for these specimens was typically ductile, as shown in Figures H13 and H14 for specimen T32-2 (E71T8-K6(H)S 12.7 mm). Similar features were also observed in specimen T28-1 (E70T-7(L)S 12.7 mm), as shown in Figures H15 and H16. Specimen T30-3, which also failed in the weld at a fracture surface angle of 21° , showed both microvoids and cleavage on the fracture surface (refer to Figures H17 to H19).

Specimen T17-2 (E70T7-K2(L)S 6.4 mm) failed at the front weld at 90° because of a significantly shorter tension leg than the shear leg (the length of the tension leg was only about 40% of the shear leg). Failure took place in the base metal. Microvoid coalescence characterized the fracture surface as shown in Figures H20 and H21.

Fracture of all specimens tested at low temperature took place on a plane at 90° from the axis of the load. The fracture surface, shown in Figures H22 and H23 for specimen T7-2 (E70T-4(H)S 6.4 mm) show a mixture of cleavage and microvoid coalescence.

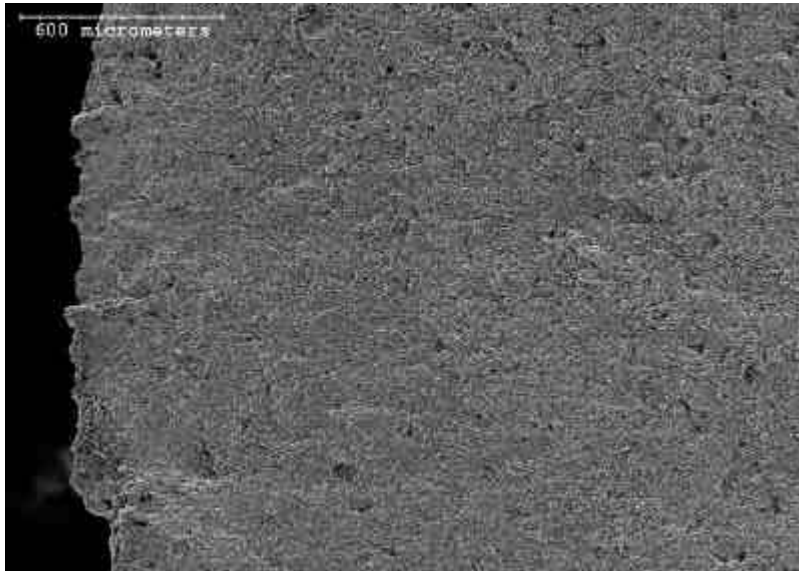

Figure H1 – Fracture Surface of Test Specimen T2-3

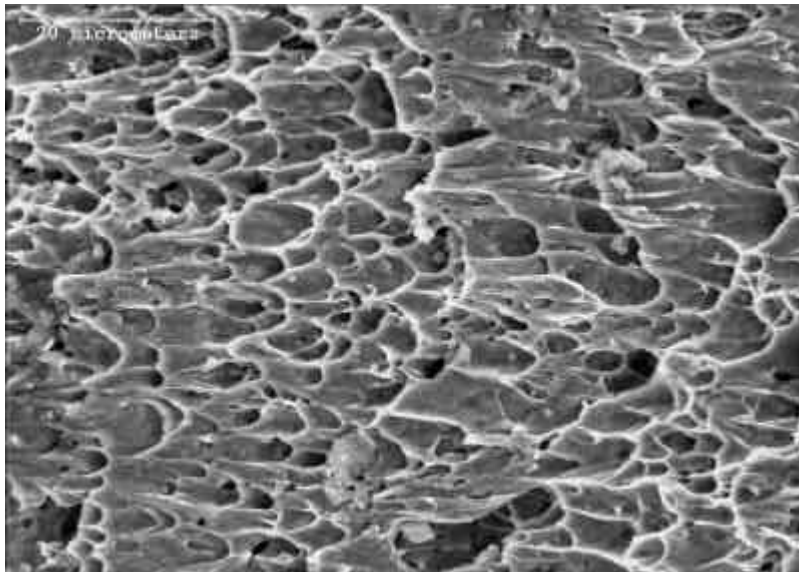

Figure H2 – Microvoid Coalescence on Fracture Surface of Test Specimen T2-3

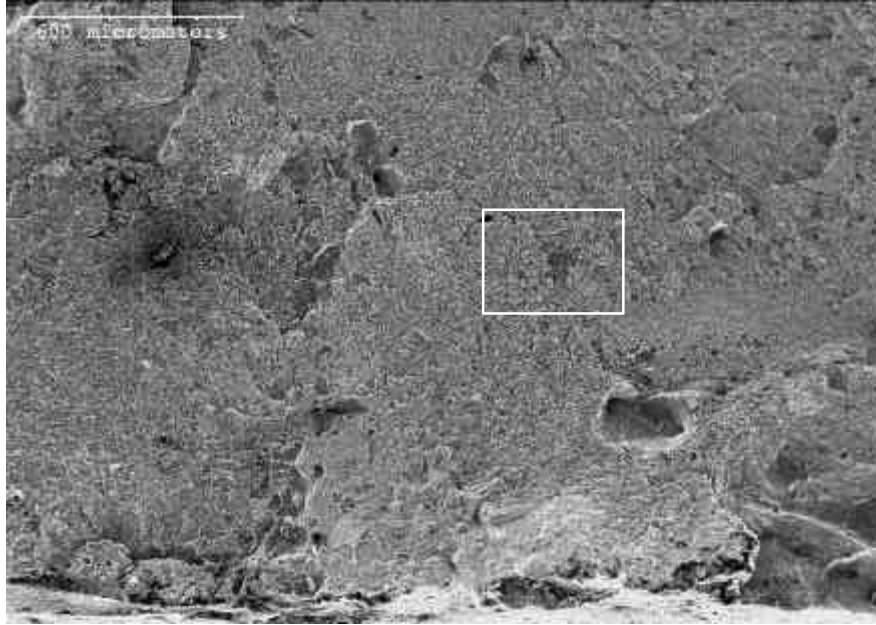

Figure H3 – Fracture Surface of Test Specimen T13-1

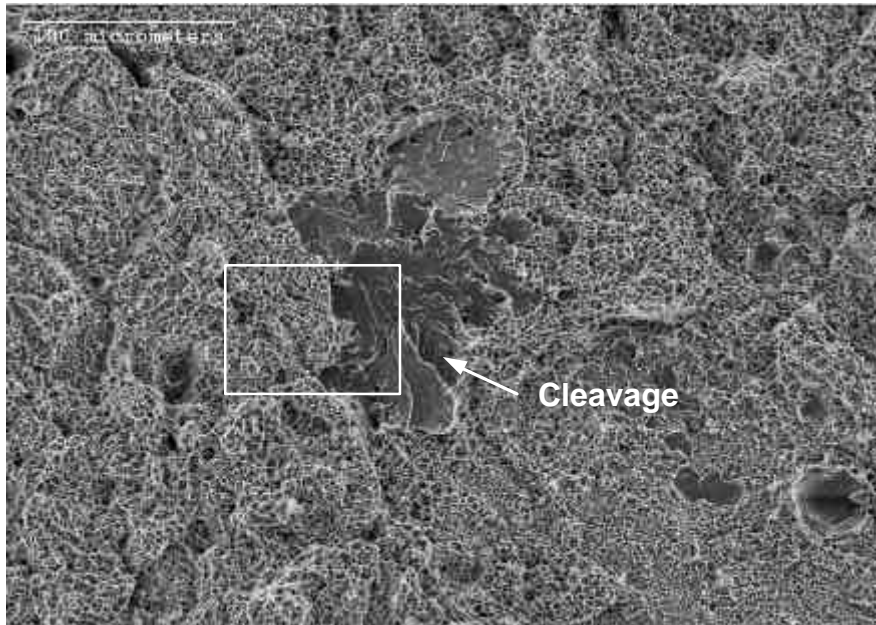

Figure H4 – Cleavage and Microvoid Coalescence on Fracture Surface of Test Specimen T13-1

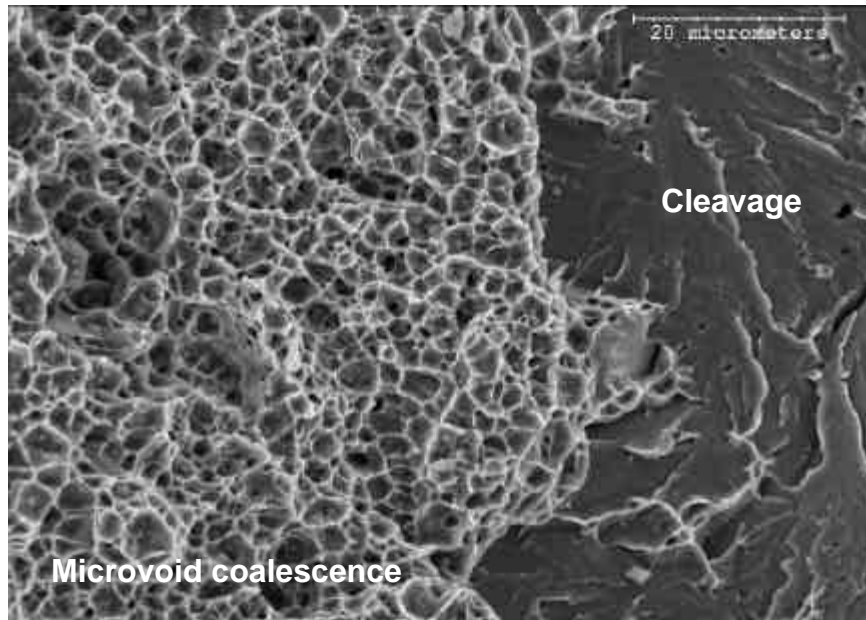

Figure H5 – Cleavage and Microvoid Coalescence on Fracture Surface of Test Specimen T13-1

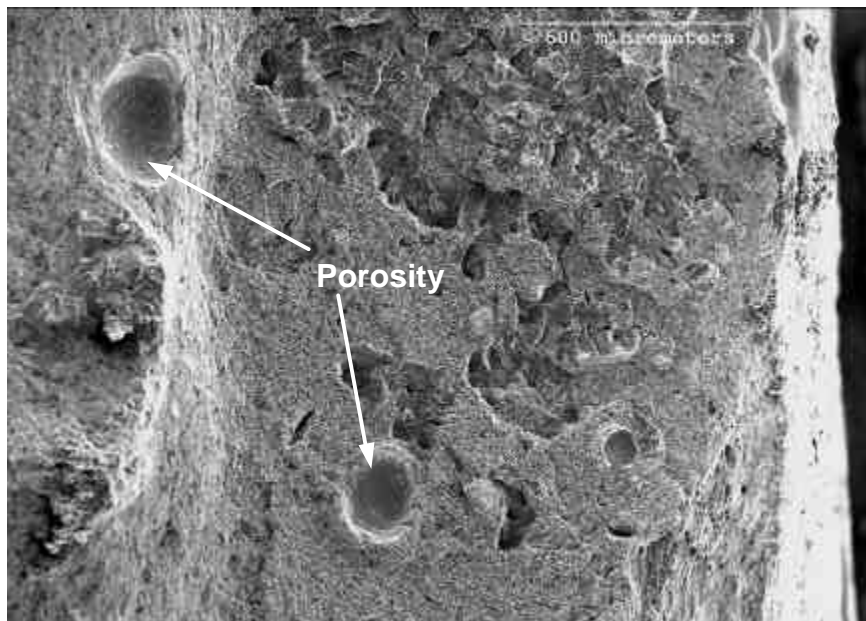

Figure H6 – Fracture Surface of Test Specimen T6-2

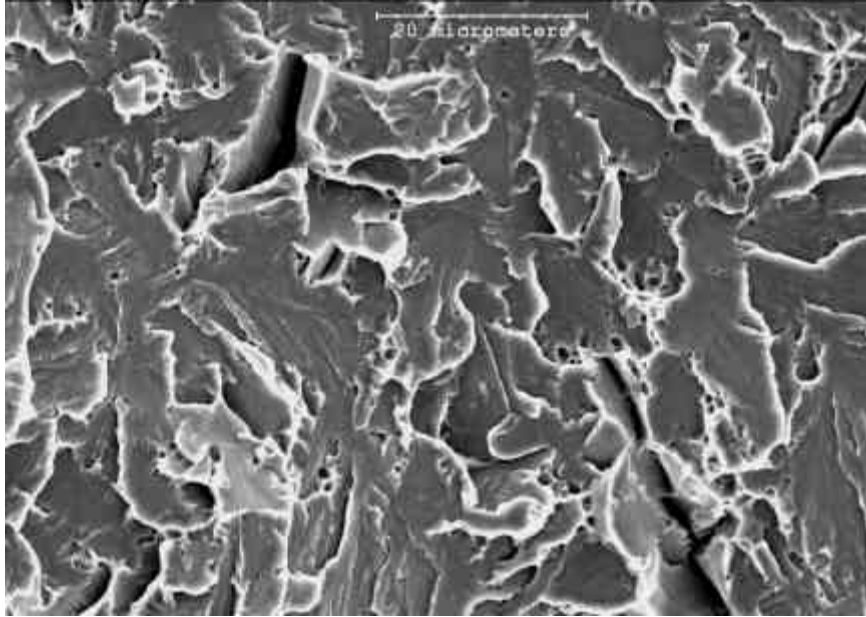

Figure H7 – Cleavage Fracture on Test Specimen T6-2

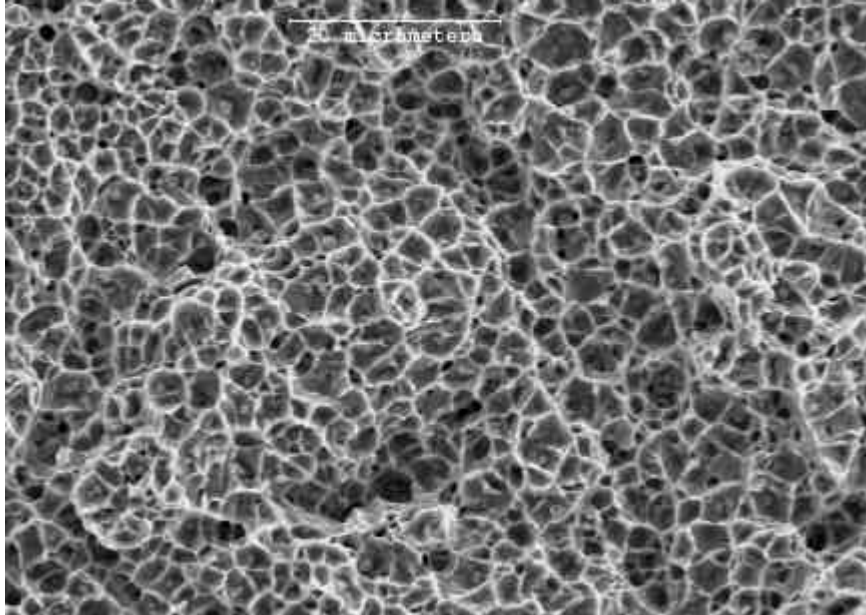

Figure H8 – Microvoid Coalescence on Fracture Surface of Test Specimen T6-2

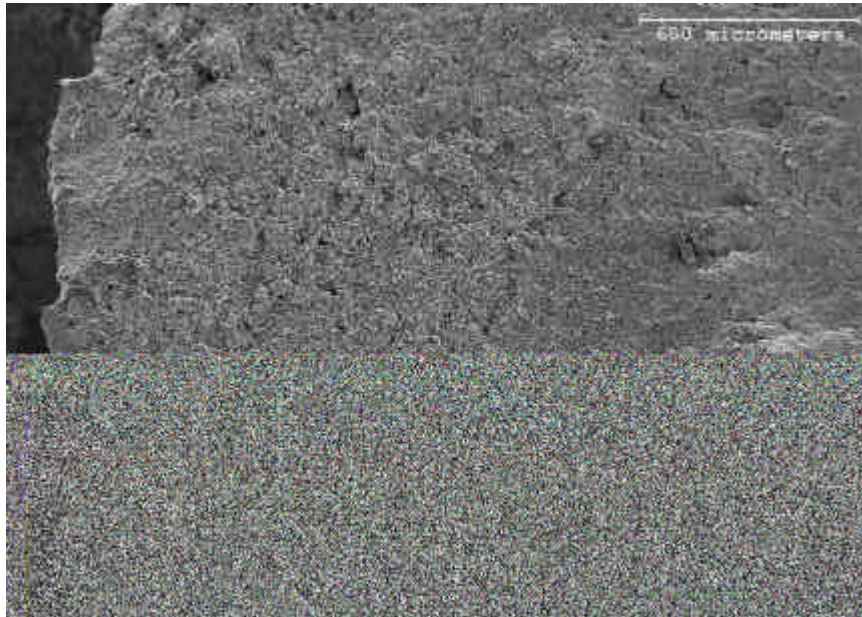

Figure H9 – Fracture Surface of Test Specimen T12-1

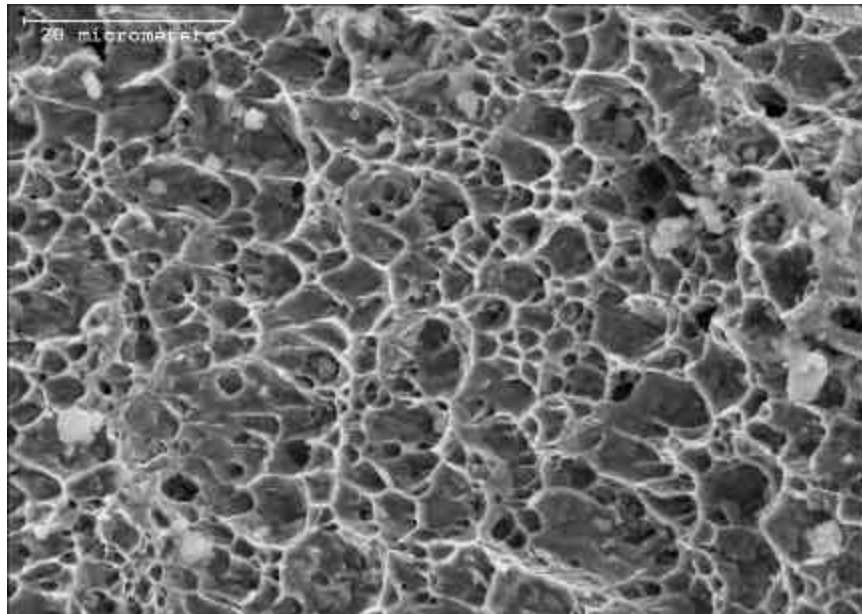

Figure H10 – Microvoids on Fracture Surface of Test Specimen T12-1

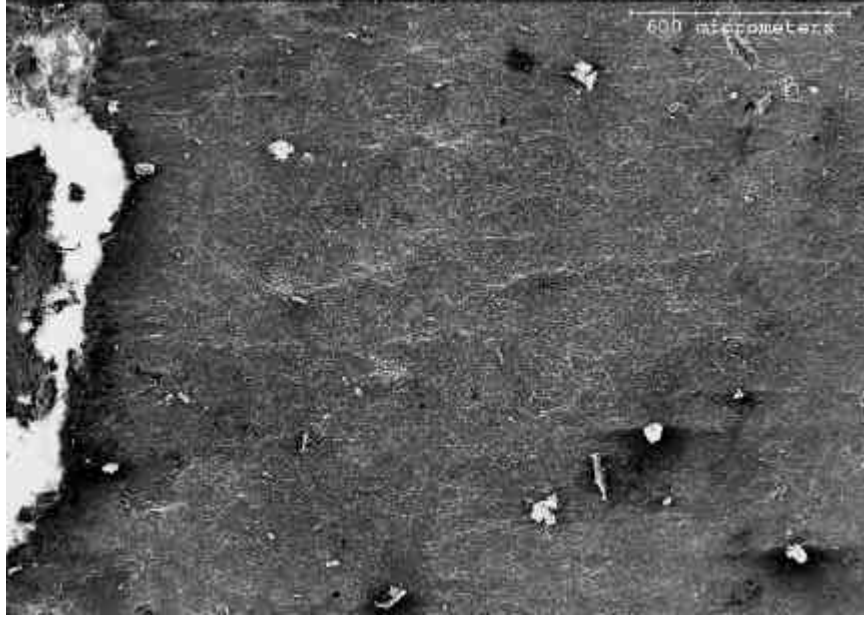

Figure H11 –Fracture Surface of Test Specimen T22-2

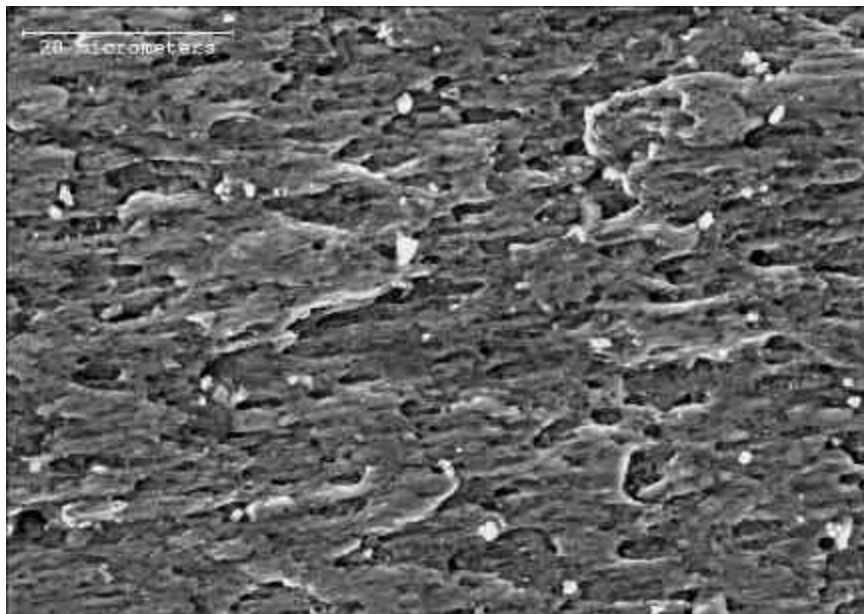

Figure H12 – Microvoid Coalescence on Fracture Surface of Test Specimen T22-2

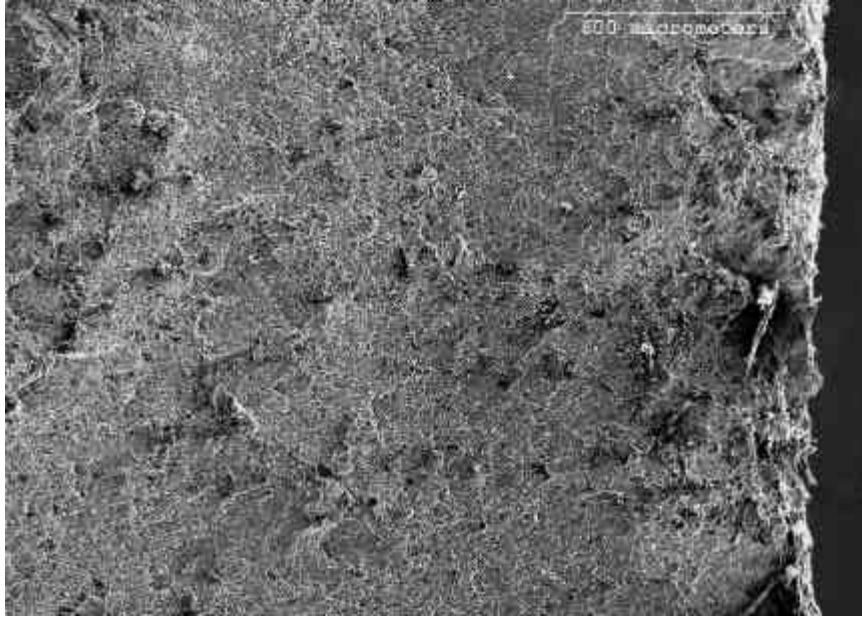

Figure H13 – Fracture Surface of Test Specimen T32-2

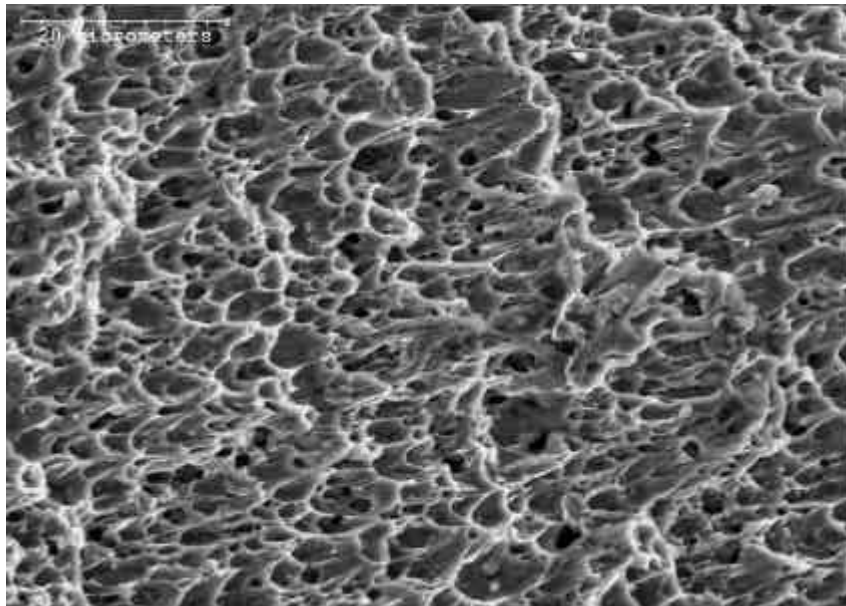

Figure H14 – Elongated Microvoids on Fracture Surface of Test Specimen T32-2

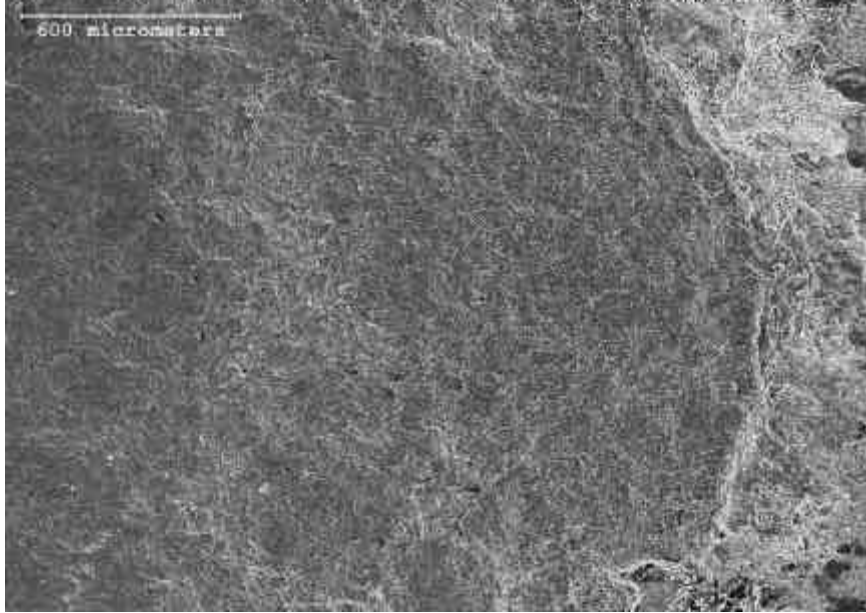

Figure H15 – Fracture Surface of Test Specimen T28-1

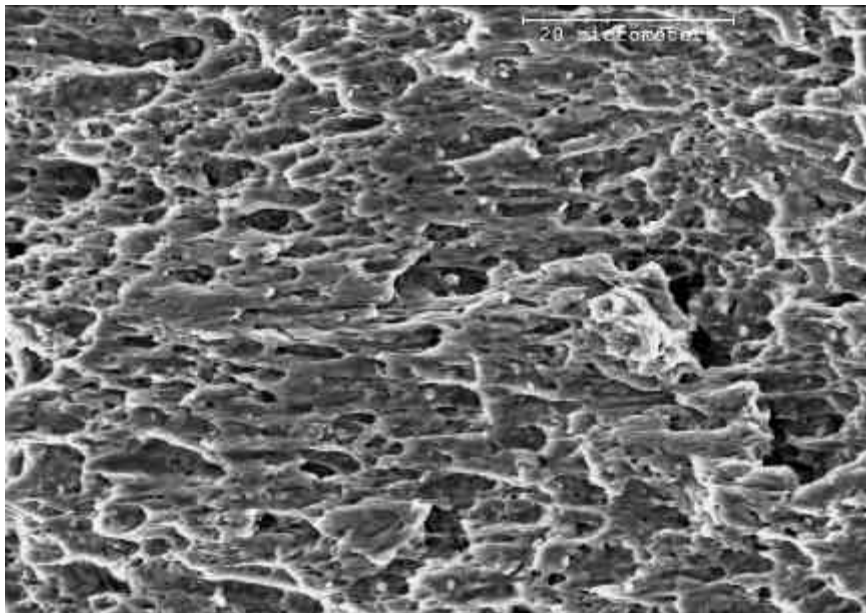

Figure H16 – Elongated Microvoids on Fracture Surface of Test Specimen T28-1

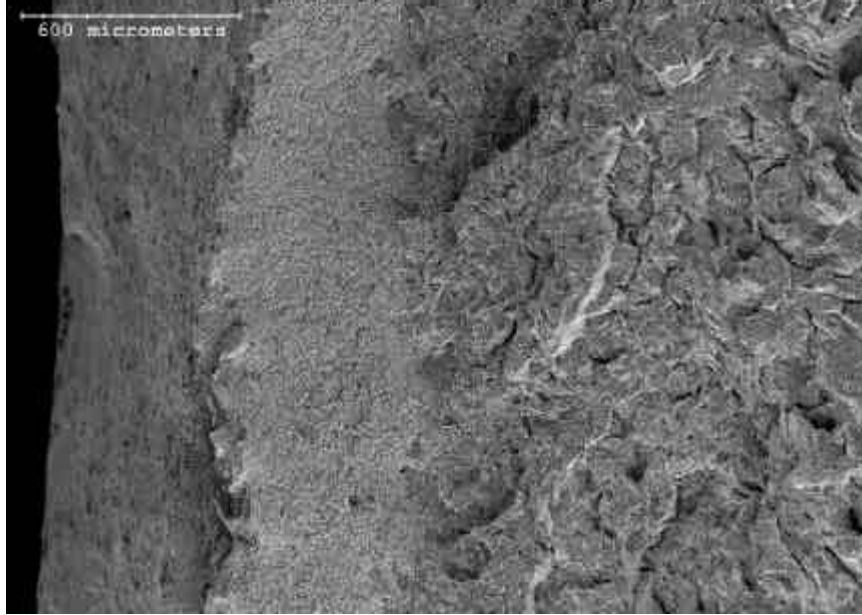

Figure H17 – Fracture Surface of Test Specimen T30-3

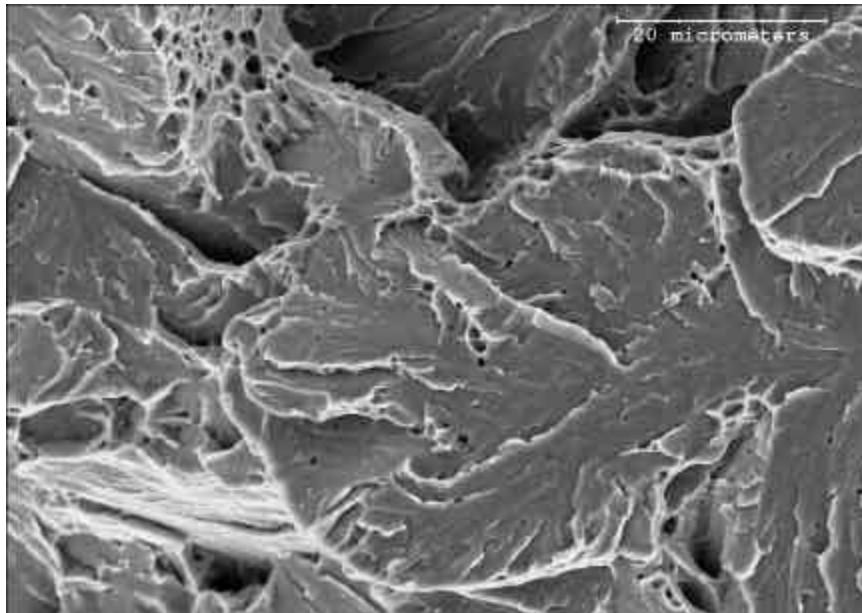

Figure H18 – Cleavage on Fracture Surface of Test Specimen T30-3

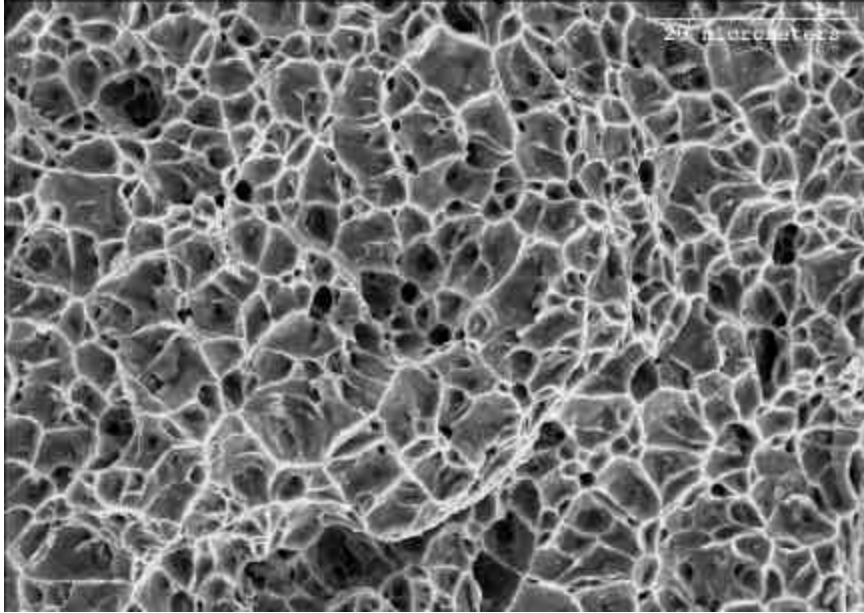

Figure H19 – Microvoids on Fracture Surface of Test Specimen T30-3

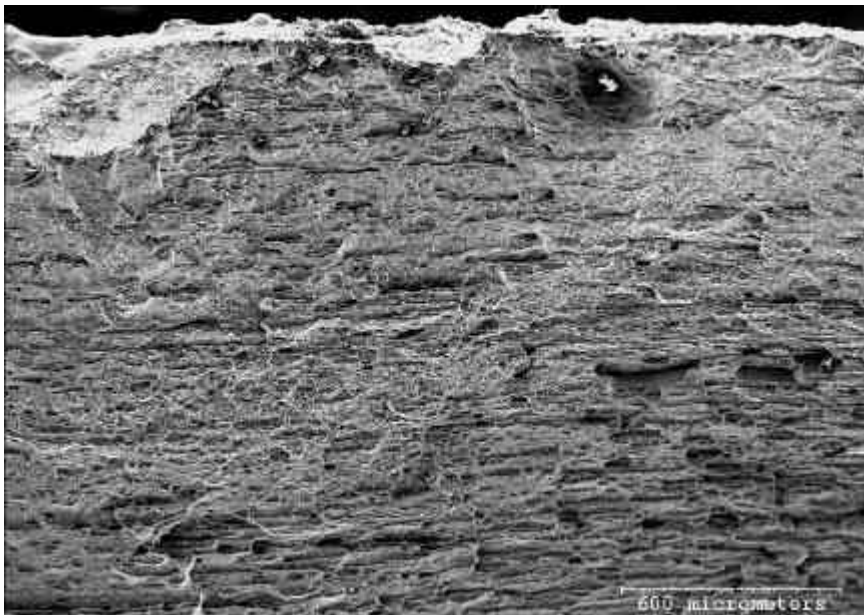

Figure H20 – Fracture Surface of Test Specimen T17-2

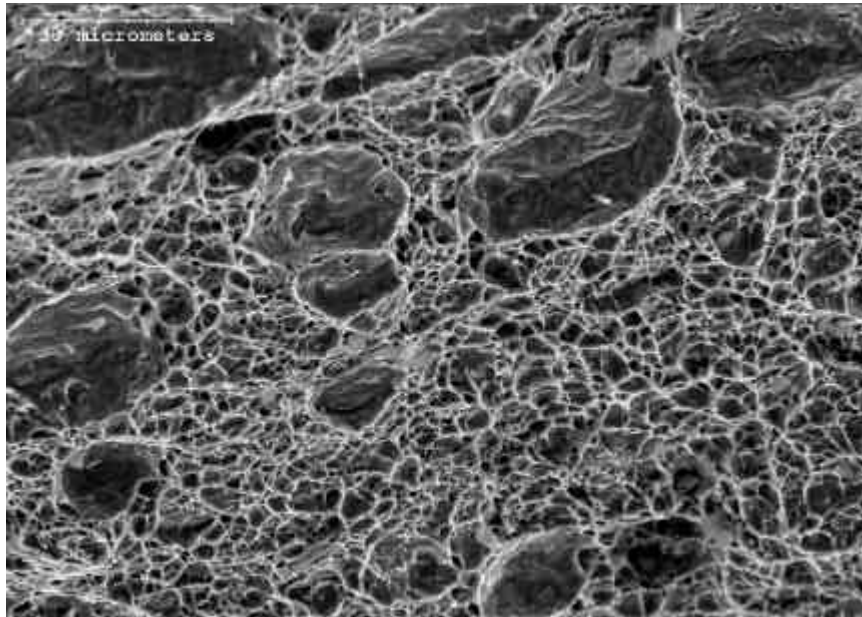

Figure H21 – Microvoids on Fracture Surface of Test Specimen T17-2

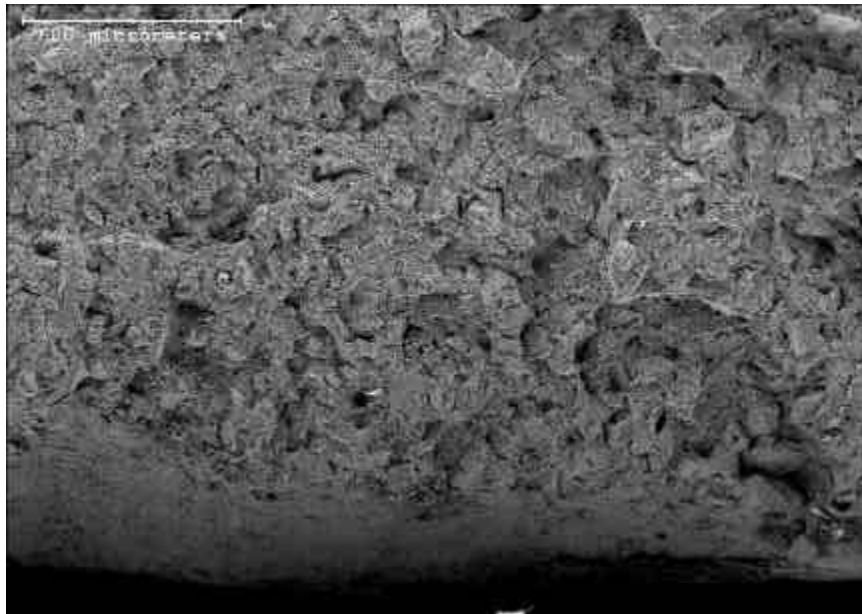

Figure H22 – Fracture Surface of Test Specimen T7-2 (Low temperature test)

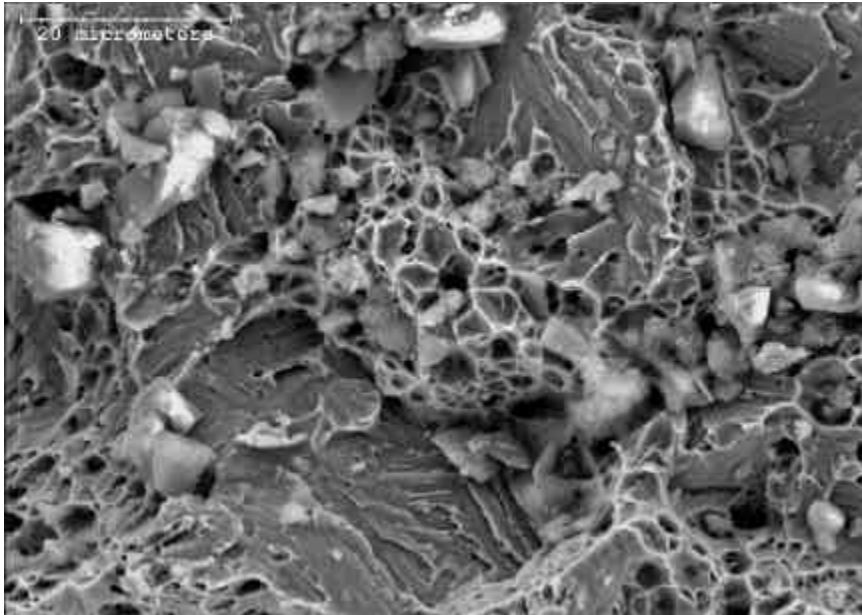

Figure H23 – Microvoid Coalescence and Cleavage on Fracture Surface of Test Specimen T7-2