



NOTICE

The quality of this microfilm is heavily dependent upon the quality of the original thesis submitted for microfilming. Every effort has been made to ensure that the highest quality of reproduction is possible.

Pages are missing from this microfilm which were not printed in the original.

Some pages may have been lost if print appeared on the original pages were typed with a poor typewriter ribbon or if the original text is a poor type set.

Previously microfimed material has been updated with the latest copy available.

Reproduction in whole or in part in any form is prohibited by the Canadian Copyright Act, R.S.C. 1970, c. 30. Please read the author's statement which accompanies this thesis.

THIS DISSERTATION
HAS BEEN MICROFILMED
EXACTLY AS RECEIVED

AVIS

La qualité de ce film est très dépendante de la qualité de l'original. Nous avons fait tous les efforts possibles pour assurer la meilleure qualité de reproduction.

Il y a des pages manquantes sur ce film qui n'ont pas été imprimées dans l'original.

Certaines pages peuvent avoir été perdues si le texte original a été typé avec une mauvaise qualité de papier ou si le texte original est une mauvaise composition.

Les documents précédemment microfilmés ont été actualisés avec la dernière copie disponible.

La reproduction en tout ou en partie de ce microfilm est interdite par la Loi canadienne sur le droit d'auteur, S.F. 1970, c. 30. Veuillez prendre connaissance des formulaires d'autorisation qui accompagnent cette thèse.

LA THÈSE A ÉTÉ
MICROFILMÉE TELLE QUE
NOUS L'AVONS REÇUE

EQUIPMENT FOR AN MATHS AND PHYSICS DEPARTMENT

by

ALEJANDRO MORALES E.

A THESIS

SUBMITTED TO THE FACULTY OF GRADUATE STUDIES AND RESEARCH
IN PARTIAL FULFILLMENT OF THE REQUIREMENTS FOR THE DEGREE
DOCTOR OF PHILOSOPHY

DEPARTMENT OF ELECTRICAL ENGINEERING

EDMONTON, ALBERTA

MAY 1977

THE UNIVERSITY OF ALBERTA
FACULTY OF GRADUATE STUDIES AND RESEARCH

The undersigned certify that they have read, and recommend to the Faculty of Graduate Studies and Research, for acceptance, a thesis entitled Experimental Study on Microwave Oven Design submitted by Alejandro McKay B. in partial fulfilment of the requirements for the degree of Doctor of Philosophy in Electrical Engineering.

W. Angus
.....
Supervisor

W. C. ...
.....
Supervisor

H. ...
.....

... Frank
.....

C. R. ...
.....

.....
External Examiner

Date *May 31st* 1977

ABSTRACT

Poor heating uniformity and a high sensitivity of conversion efficiency to loading conditions are the main problems in the performance of microwave ovens. With conventional design techniques only a partial solution to these problems is achieved using a mode-stirrer. However, it is shown that this device reduces conversion efficiencies due to increased reflections to the magnetron.

Frequency is shown to be the most important parameter in controlling the performance of resonant microwave heating systems. A new technique which makes use of a frequency agile source is developed. By controlling the frequency of this source in an experimental cavity a large improvement in conversion efficiency, as compared to a commercially available domestic microwave oven, is demonstrated. Frequency sweeping of the source is shown to be effective in reducing the sensitivity of efficiency to loading conditions, as well as improving heating uniformity.

With a frequency agile source and a special electronic controller it is shown that temperature patterns in a load can be tailored to a considerable degree. A simple mathematical model is developed, which predicts with good

accuracy the temperature pattern in low profile loads when exposed to electromagnetic energy in a resonant cavity.

Multiple transistorized microwave power sources and a single transistorized source using power dividing-combining techniques, are described as possible approaches to the design of an all solid-state microwave oven. The former is not at present feasible due to energy cross-coupling between sources and neither is cost competitive.

Transistorized microwave sources are found to be advantageous for low power applications. A 20 watt, 915 MHz source is designed, built and used in the fast curing of epoxy glue.

ACKNOWLEDGMENT

I wish to thank Dr. W.R. Tinga and Dr. W.A.G. Voss for their encouragement and assistance during the course of this project. I am also very grateful to Mr. A. Huizinga for his competent technical support. The assistance of Dr. C. Walker and Mr. J. Howell with some of the computer programs is also appreciated.

I am thankful to Alberta Government Telephones for the scholarship awarded to me in the last ten months of this project, to Canada as a whole, for having given me the opportunity to study here, and to my university, the Universidad Catolica de Chile, for its constant support. The support of the National Research Council of Canada through grants A2272 and A7626 is gratefully acknowledged.

I especially wish to thank God and my parents for having given me the necessary means to achieve my academic goals. Finally, I wish to express my deepest gratitude to my wife, Laila, without whose constant encouragement, patience and help, my studies in Canada would not have been possible.

TABLE OF CONTENTS

CHAPTER		PAGE
1	MICROWAVE HEATING: THE PROBLEMS IN PERSPECTIVE	1
	1.1 Introduction	1
	1.2 The Performance of Microwave Ovens	2
	1.2.1 Heating Uniformity and Temperature Pattern Control	3
	1.2.2 Conversion Efficiency and Its Variation with Loading Conditions	4
	1.3 New Design Approaches	6
	1.3.1 Frequency Agile Microwave Power Source	7
	1.3.2 Solid State Microwave Power Sources	8
	1.4 Overview of Thesis Content	10
2	PRINCIPLES OF OPERATION AND DESIGN OF MICROWAVE OVENS	12
	2.1 Electromagnetic Fields in a Microwave Cavity	12
	2.2 Power Absorbed by a Lossy Dielectric in a Microwave Cavity	16
	2.3 Circuit Efficiency in a Loaded Cavity.	19
	2.4 Microwave Power Sources.	23
	2.5 Coupling Structures.	24
	2.6 Turntables and Mode Stirrers	26
3	MEASUREMENT AND PREDICTION OF TEMPERATURE PATTERNS.	29
	3.1 Measurement of Temperature Patterns.	29
	3.2 Prediction of Temperature Patterns	31
	3.2.1 Introduction.	31
	3.2.2 Experimental Procedures	32
	3.2.3 Theoretical Analysis.	35
	3.2.4 Computations and Results.	39
	3.2.5 Discussion.	40
	3.3 Temperature Pattern Tailoring.	49

4	MICROWAVE TO HEAT CONVERSION EFFICIENCY.	51
	4.1 Overall Efficiency of Microwave Ovens	51
	4.2 Circuit Efficiency of Microwave Ovens	53
	4.2.1 General Experimental Procedures.	54
	4.2.2 Circuit Efficiency of Experimental Cavity Using a Conventional Magnetron	55
	4.2.3 Circuit Efficiency of a Domestic Microwave Oven.	57
	4.2.4 Mode Stirrer Effect in Experimental Cavity Using a Conventional Magnetron	61
	4.3 Importance of Source Bandwidth on Circuit Efficiency.	67
	4.3.1 Circuit Efficiency as a Function of Bandwidth Swept by the Source.	68
	4.4 Conclusions	71
5	CAVITY EXCITATION WITH A FREQUENCY AGILE SOURCE.	73
	5.1 The Voltage Tunable Magnetron (VTM)	74
	5.2 Maximization of Circuit Efficiency.	77
	5.2.1 Conventional Automatic Tuning Systems.	77
	5.2.2 Frequency Agile Source and Electronic Tuner.	79
	5.2.3 Circuit Efficiency of Experimental Cavity Using the VTM and Electronic Tuner	82
	5.3 Heating Uniformity Test	85
	5.4 Temperature Pattern Tailoring	89
6	CONCLUSIONS.	94
	REFERENCES	97

APPENDIX

I	SOLID STATE MICROWAVE POWER GENERATORS	106
---	--	-----

	1.- Transistorized Microwave Generators.	106
	2.- Multiple Sources in Microwave Heating Systems.	109
	3.- Power Dividing-Combining Technique and Low Power Applications	112
	4.- Design of a Transistorized ISM Microwave Power Source	117
II	THEORY OF OPERATION OF ELECTRONIC TUNER	127
III	THEORY OF OPERATION OF THE DISCRETE FREQUENCY MODULATOR	134
IV	COMPUTER PROGRAM TO OPTIMIZE CAVITY DIMENSIONS.	136

LIST OF FIGURES

FIGURE		PAGE
2.1	Typical return loss response of a lossy cavity	14
2.2	An equivalent circuit of a lossy cavity in the vicinity of resonance for mode j	20
2.3	Schematic representation of two typical coupling structures used in microwave ovens	26
3.1	Reference system for a cavity	33
3.2	The four load positions studied	33
3.3	Mode 211. Temperature patterns for positions 1 and 2	41
3.4	Mode 211. Temperature pattern for position 3	42
3.5	Mode 211. Temperature pattern for position 4	43
3.6	Mode 112. Temperature pattern for position 1	44
3.7	Mode 112. Temperature pattern for position 2	45
3.8	Mode 112. Temperature pattern for position 3	46
3.9	Mode 112. Temperature pattern for position 4	47
4.1	Load positions at each of the three levels chosen in the experimental cavity	56
4.2	Relative circuit efficiencies for experimental cavity and conventional magnetron	58
4.3	Load positions at each of the three levels chosen in the domestic oven	59
4.4	Relative circuit efficiencies for the domestic oven	60
4.5	Frequency spectrum of conventional magnetron exciting the experimental cavity	63
4.6	Relative circuit efficiencies for experimental cavity and conventional magnetron, without isolator	64
4.7	Relative circuit efficiencies for experimental cavity and conventional magnetron, with isolator	66
4.8	Relative circuit efficiencies for the experimental cavity, for different source bandwidths swept at constant input power	70

5.1	Cross section of a voltage tunable magnetron	74
5.2	Simplified schematic of the VTM-electronic tuner system	81
5.3	Relative circuit efficiencies for experimental cavity using the VTM and electronic tuner as source	83
5.4	Comparison of circuit efficiencies obtained: in the experimental cavity with the VTM-electronic tuner system and in the domestic oven	86
5.5	Percentage improvement in circuit efficiency using the VTM, electronic tuner and probe coupler, with respect to the domestic oven	87
5.6	Superposition of three temperature patterns using the VTM and the discrete frequency modulator	91
A1.1	Epoxy patch cured with a 16 W transistorized microwave generator and a coaxial applicator	116
A1.2	Three schemes that can meet the power source specifications	118
A1.3	Amplifier schematic circuit	122
A1.4	Oscillator schematic circuit	125
A2.1	Peak Detector schematic circuit	128
A2.2	Output voltage from a positive peak detector	129
A2.3	Memory and D/A schematic circuit	132
A3.1	Discrete Frequency Modulator schematic circuit	135

LIST OF SYMBOLS

a, b, d	cavity dimensions along x, y and z
A, B, D	cavity dimensions along x, y and z in appendix IV
c	velocity of light in free space
C	capacitance
C_p	specific heat at constant pressure
\hat{E}	electric field vector
f	frequency
f_c	cutoff frequency
F	frequency in appendix IV
F	load filling factor
h	spacing between stripline and ground plane
\hat{H}	magnetic field vector
l, m, n	number of half sine variations along x, y and z
L, M, N	number of half sine variations along x, y and z in appendix IV
L	inductance
MPAL	maximum power available to the load
MTBF	mean time between failures
n_o, n_i	ideal transformer turns ratio
P	power
Q	quality factor
R	resistance
t	time
T	temperature
V	volume (or voltage where so defined)
W	stripline width
Z	impedance
β	phase constant
ϵ_o	permittivity of free space
ϵ_r'	real part of relative dielectric constant

ϵ_r''	imaginary part of relative dielectric constant
λ	wavelength
μ_0	permeability of free space
η	efficiency
η_0	characteristic impedance of free space
ρ	density
ω	angular frequency

MICROWAVE HEATING: THE PROBLEM, IN PERSPECTIVE

1.1 Introduction

Dielectric heating at frequencies below 100 MHz was a well known technique in the decade of the thirties (1). Since the power converted to heat in a lossy dielectric is proportional to the frequency and to the square of the electric field within the dielectric, for a given frequency, heating rates are limited by the voltage breakdown of the dielectric. High heating rates can be achieved by increasing the frequency, however, at the time, this was not possible due to the lack of high power high frequency (>1 GHz) sources. Dielectric heating at microwave frequencies became feasible after the invention of the pulsed magnetron during World War II and the subsequent development of high power CW magnetrons.

In 1946 the first microwave oven for cooking purposes was made by Raytheon Manufacturing Co. (2) and an improved model having a larger oven was operating in a number of restaurants by 1947 (3). The considerable savings in cooking time and the fast heating of precooked meals, which are possible in a microwave oven, were the most attractive

features, which began a slow development of a commercial market for these modern appliances. Their large size and high cost were the main disadvantages which precluded them from being sold as home appliances. By 1956, however, microwave ovens had been reduced in size and price to the point that 2,500 units were sold for home use that year (4). Better door seals, smaller overall size, longer magnetron life and lower prices, together with widespread awareness of the advantages of this appliance in a society with changing lifestyles (5), are the main causes for the recent phenomenal growth of the domestic microwave oven market. In 1974 approximately 700,000 domestic microwave ovens were sold in the United States (6,7) with projections for annual sales of 2,050,000 units in 1980 (7). In other studies it is estimated that by 1985 one out of every two families in the U.S. will own a microwave oven (8). The growth of the commercial microwave oven market has not been as great but it is also increasing (9). Microwave oven sales are also on the rise in Europe and Japan (10,11).

1.2 The Performance of Microwave Ovens

The increasing demand for microwave ovens is a clear indication that their performance is considered quite acceptable by the public; however, there are two areas where

there is still considerable room for improvement.

1.2.1 Heating Uniformity and Temperature Pattern Control

Since the early days of microwave heating technology, obtaining uniform heating of a dielectric exposed to microwave energy in a metallic enclosure has been a major concern of engineers and scientists (12,13,14,15). Heating uniformity in the load, (i.e. the object being heated) depends on the dielectric properties and their variations within the load, its shape and size, the limited penetration depth of the fields and the electric field pattern in the presence of the load. The fact that loads processed in a microwave oven vary over a wide range of dielectric properties, shapes and sizes, and that the choice of operating frequency is practically limited to two of the ISM bands (915±25 MHz and 2,450±50 MHz), has led the microwave oven designer to improve heating uniformity by manipulating the electric field patterns in the oven cavity. A large number of approaches have been suggested, many of which can be found in the literature (16,17), but the most successful and used in almost all commercial and domestic microwave ovens today, is the mode-stirrer. This device, for one, has allowed the microwave oven to become an acceptable appliance but heating uniformity is still a basic problem (18,19) and

research in this area continues (20,21,22).

Mode-stirrers operate on the principle of randomizing the field patterns in the cavity as much as possible to avoid the generation of hot and cold spots in the load where the electric field intensities are high and low respectively. This random action, together with the lack of control over parameters such as the frequency of the microwave power source, precludes, with present design techniques, the possibility of tailoring temperature patterns. However, this would be a very desirable feature, especially, in microwave ovens for commercial and institutional use where, for example, different heating is to be provided to particular items in a tray with a complete meal. Lacking a technique for tailoring temperature patterns, efforts are being made to develop sophisticated food packaging and handling techniques (23,24).

1.2.2 Conversion Efficiency and Its Variation with Loading Conditions

The amount of published work on the efficiency of microwave ovens, and ways of improving it, is surprisingly small when compared to the published work on the heating uniformity problem. This can be explained, perhaps, by

considering that the main attraction of microwave ovens has been their time saving capability; however, the rising cost of energy and the increasing use of this appliance makes the study of microwave oven efficiency a very relevant issue. One major manufacturer has recently committed itself to improve the overall efficiency of its microwave ovens by 20% by 1980 (8).

For commercially available microwave ovens, the overall efficiency, i.e. from power line to load, lies between 44% and 50% for a 1 liter water load according to one study (25) and between 38% and 46% according to another (19). The overall efficiency is, essentially, the product of three factors: power supply efficiency, magnetron efficiency and conversion or circuit efficiency. Typical power supply and magnetron efficiencies can be considered to be 95% and 65% respectively (26), so for an oven with, say, 45% overall efficiency the circuit efficiency would be 73%. Losses in converting the power available from the magnetron to heat, are due, in part, to losses in the cavity walls and feeding structure but arise mainly from a poor impedance match between the magnetron and the loaded cavity. This mismatch condition and, hence, the circuit efficiency, are worse for small loads and vary considerably with the position of the load within the cavity. With present microwave oven design techniques it does not appear possible to solve this

problem.

A maximum theoretical overall efficiency figure can be estimated by considering that: a) it is not likely that a power supply efficiency much higher than 95% can be achieved, b) since magnetrons have been operated with efficiencies of up to 86% (27), it is conceivable that mass produced magnetrons with an 80% efficiency can be made and c) since circuit efficiencies of 97% were measured in a perfectly matched cavity during the course of this work, 95% can be considered a reasonable maximum figure for mass produced microwave ovens. Thus, an estimated maximum theoretical overall efficiency of 72% results. This figure is of the order of 50% higher than what has been achieved so far and, therefore, it is evident that trying to improve the efficiency of microwave ovens is a worthwhile effort.¹

3.5 New Design Approaches

the course of the development of microwave ovens the microwave source used has always been the conventional CW magnetron. This tube is not only a narrowband device,

¹Energy conservation legislation in the U.S.A. is being enacted which would require appliance manufacturers to state the efficiencies of their appliances.

typically ± 9 MHz at 2,450 MHz (28,29), but its frequency cannot be controlled independently of other tube or external circuit parameters. These characteristics seriously limit the possibilities of improving the performance of microwave ovens.

Two approaches to: improve heating uniformity, tailor temperature patterns and improve circuit efficiency, are investigated in this thesis.

1.3.1 Frequency Agile Microwave Power Source

The possibility of obtaining good heating uniformity increases with the number of different modes (field patterns) which can be excited in the loaded cavity. To take advantage of the modes which can be sustained by a multimode cavity in the allowable 100 MHz bandwidth at 2,450 MHz, for instance, the microwave power source must be capable of operating in that bandwidth. Thus, a source with a sufficiently large ($\approx 5\%$) bandwidth is clearly desirable. Moreover, if the frequency of the source can be set in a simple manner, frequency sweeping or excitation of the cavity in selected modes, are ways by which improved heating uniformity and temperature pattern tailoring become possible. A voltage tunable magnetron (VTM) has been used

in this investigation. Its frequency is a linear function of the anode voltage and the output power is essentially constant in a 16% bandwidth at 2,450 MHz.

In a multimode cavity, the frequency (or frequencies) at which maximum circuit efficiency is achieved, vary quite drastically with loading conditions. Consequently, if the microwave power source operates within a narrow bandwidth, the circuit efficiency will vary with loading in the same way. Maximum circuit efficiency and minimum circuit efficiency sensitivity to loading can be achieved if the frequency of the source can be set to the optimum value for each loading condition. The VTM and an electronic tuner specifically developed for the purpose have been used to investigate this technique.

1.3.2. Solid State Microwave Power Sources

Solid-state devices have many attractive features for microwave heating applications. Due to their low output power, however, some power combining technique is required if they are to be used in microwave ovens. The two techniques analyzed in this thesis are: a) to use multiple low power sources exciting the cavity at different frequencies and b) to combine a number of solid-state

9

devices to obtain a high power amplifier or oscillator.

The multiple source approach can yield good heating uniformity because each source can be made to excite a different mode, but tailoring temperature patterns is difficult to achieve, since the smaller the number of modes required to obtain a given pattern the lower the power available in the cavity. The performance of such a technique, as far as circuit efficiency is concerned, is difficult to establish since it depends on the number of sources used. In any case, the feasibility of the multiple source approach is subject to the solution of the problem of energy cross-coupling between sources.

The solid-state amplifier or oscillator approach can be used to improve heating uniformity, to tailor temperature patterns and to improve circuit efficiency, using the same techniques outlined for the frequency agile source. However solid-state sources do not represent as good an option as VTM's, at least for now.

It is evident that for the successful use of any of the new techniques outlined in this chapter, as large a bandwidth as possible should be available. In view of very important decisions on frequency allocations which are to be made in the near future (30), it is timely that the

potential of these new techniques, as means for improving the performance of microwave ovens, be assessed.

1.4 Overview of Thesis Content

First, the principles of operation of microwave ovens and conventional techniques for their design are reviewed. In view of the possibility of being able to tailor temperature patterns, using the frequency agile source approach, a simple mathematical model is developed to predict the temperature pattern in a low profile load when the cavity is excited in a known mode. Theoretical and experimental results for two modes are compared. In chapter 4, circuit efficiency measurements are made in an experimental cavity and in a commercially available domestic microwave oven, for a wide variety of loading conditions. Also, experiments are performed to gain insight on the operation of mode-stirrers and to study the effect, on the circuit efficiency, of continuously frequency sweeping the microwave energy source. The technique of using a frequency agile source and the special electronic tuner is developed in chapter 5. Circuit efficiency measurements are performed using this technique and the results compared with those obtained in chapter 4. An experiment is performed to explore the feasibility of tailoring temperature patterns using a

frequency agile source and a test, designed for measuring heating uniformity, is applied to the experimental cavity when the source is frequency swept. The state-of-the-art of microwave power transistors is reviewed in appendix I and possible schemes for the design of an all solid-state microwave oven are analyzed. The appendixes contain detailed information on the design and construction of: a 20 watt transistorized microwave source, the electronic tuner and a three frequency modulator. Also, a computer program to optimize the dimensions of a rectangular cavity is included. The program finds the dimensions, around given target values, which maximize the number of modes that the cavity can sustain within a given bandwidth.

The factors affecting the operation of a microwave oven are many. They are interrelated and dependent on loading conditions, conditions which are beyond the control of the designer. It is not believed that a theoretical analysis of the practical oven-load configuration, which has been described by a well known investigator as of "overwhelming complexity" (18), is the most suitable approach to finding ways for improving the performance of microwave ovens. Some theoretical work has been published (31) but it is not known to have been fruitful in a practical sense. For the most part, an experimental approach has been taken in this thesis.

CHAPTER 2

PRINCIPLES OF OPERATION AND DESIGN OF MICROWAVE OVENS

It is necessary to review briefly the basic principles of operation of microwave ovens in order to understand the true nature of the problems mentioned in the previous chapter. Moreover, it will be useful to critically review the conventional design techniques of microwave ovens so that their advantages and disadvantages can be appreciated.

2.1 Electromagnetic Fields in a Microwave Cavity

For electromagnetic energy to be stored in a resonant cavity, the fields must satisfy the boundary conditions imposed by the cavity. For an empty and made of perfectly conducting walls these conditions are that tangential electric fields, or normal magnetic fields, must vanish at the walls. These conditions, in practice, are essentially satisfied by metals such as copper, aluminum, stainless steel, painted steel, etc.

The field configurations, or modes, that satisfy the boundary conditions are divided into TE and TM types, depending on whether they have a magnetic or electric field component in the arbitrarily chosen direction of propagation

of the wave. The field pattern of each mode is that of a three dimensional standing-wave with maxima and minima occurring regularly throughout the cavity.

For a rectangular cavity the resonant frequencies of TE and TM modes are given by:

$$f = \frac{c}{2} \sqrt{\left(\frac{l}{a}\right)^2 + \left(\frac{m}{b}\right)^2 + \left(\frac{n}{d}\right)^2} \quad (2.1)$$

where: f = frequency

c = velocity of light in free space

l, m, n = number of half sine variations along x, y and z

a, b, d = cavity dimensions along x, y and z

Within a prescribed bandwidth not all the combinations of l, m and n , which are a solution for (2.1), constitute a mode. Equation (2.1) does not take into account boundary conditions which impose the following restrictions when z is taken as the direction of propagation :

a.- No mode can exist if any two of the integers l, m and n are zero.

b.- If n is zero the mode can only be a TM mode.

c.- If l or m are zero the mode can only be a TE mode.

Sets of l, m and n in which all three integers are different from zero represent TE and TM modes. These have the same

resonant frequency but different field configurations and are called degenerate modes (32).

The cavity Q for a mode with resonant frequency f_0 is defined as:

$$Q = \frac{2\pi f_0 U}{P_L} \quad (22)$$

where: U = time-average energy stored in the cavity

P_L = average power loss

For a cavity which is lossless or has very low losses, the Q for any mode is so high that modes appear discretely distributed through the frequency spectrum. If a lossy dielectric load is placed in such a cavity, the Q of those modes for which power is dissipated in the load are reduced. This broadens their resonance curve, in general, to the point of overlapping one another as shown by a typical return loss response in Figure 2.1.

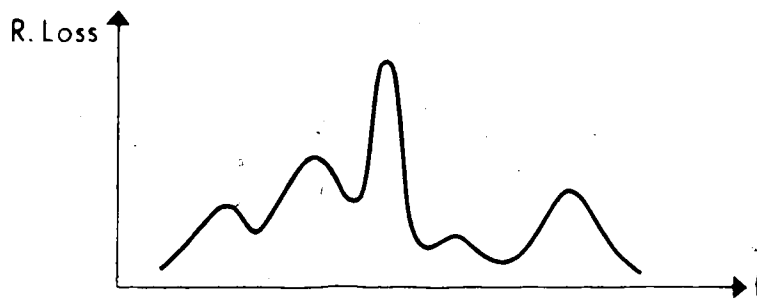

FIGURE 2.1 Typical return loss response of a lossy cavity.

Also, the resonant frequency of each mode is shifted because the dielectric load alters the balance between the energy stored in the electric and magnetic fields. Yet another effect that can occur in a loaded cavity is the splitting of degenerate modes (23). Since these modes have the same resonant frequency but different field patterns in the absence of perturbations, the load can cause these modes to split, shifting their resonant frequency by different amounts.

The extent to which these effects occur depends on the loading conditions, i.e., load size, shape, dielectric properties and position in the cavity. Loading conditions in a microwave oven vary over a wide range. Therefore, to obtain a return loss response free of regions where little or no power would be coupled to the load, a high density of modes is required within the frequency range of the microwave source. This is indeed the main consideration in calculating the dimensions of the cavity. However, for small loads, the Q of each mode is usually high enough that the return loss response exhibits sharp peaks which may be widely separated from each other by regions of very low return loss.

2.3 Power Absorbed by a Lossy Dielectric in a Microwave Cavity

The power absorbed by an element of volume ΔV of a lossy dielectric exposed to electromagnetic fields is given by:

$$\Delta P = K f \epsilon_0'' |\hat{E}|^2 \Delta V \quad (23)$$

where P = power

$$K = 2\pi f \epsilon_0$$

ϵ_0 = permittivity of free space

ϵ_0'' = imaginary part of relative dielectric constant

\hat{E} = electric field vector

In this equation it is assumed that ϵ_0'' and $|\hat{E}|$ are constant within ΔV .

The temperature rise corresponding to an absorbed power ΔP during t seconds is given by:

$$\Delta T = \frac{\Delta P t}{C_p \rho \Delta V} \quad (24)$$

where: T = temperature

C_p = specific heat at constant pressure

ρ = density

This equation assumes that c_p and ρ are constant within ΔV and with respect to temperature. Substituting:

$$\Delta T = \frac{k f \epsilon''}{c_p \rho} t |\hat{E}|^2 \quad (2.5)$$

Ideally, ΔT should be constant for all points in the load unless some special cooking effect, like browning, is desired. Differential temperature rise in a typical load processed in a microwave oven can be due to :

- 1.- Variations of c_p , ρ and ϵ'' throughout the load and variations of these parameters due to their temperature dependence.
- 2.- Variation of $|\hat{E}|^2$ throughout the load.

Because many of the above parameters are not easily controllable, the problem of achieving good heating uniformity is an extremely difficult one. The characteristics or properties of the load are beyond the control of the microwave oven designer and, therefore, he can only attempt to improve heating uniformity by controlling the pattern of $|\hat{E}|^2$ in the load.

An electromagnetic wave transmitted into a lossy

dielectric decays exponentially as it penetrates and, for a simple case like a plane wave propagating into a half space of lossy dielectric material, the attenuation constant and parameters such as penetration depth or half power depth can be calculated. The case of a load in a microwave oven, however, is that of a finite volume of lossy dielectric subjected to multidirectional plane waves and calculating the resultant field pattern is an extremely difficult task (31).

If an empty cavity is excited in a known mode the electric field pattern is reasonably well defined, but in the presence of the load, it can be severely distorted. In addition, the direction of the electric field vector at any point on the surface of the load, determines its value just inside the load. If the air surrounding the load is medium 1 and the load medium 2, at the boundary, $\hat{E}_2 = \hat{E}_1$ if the field is parallel to the load and $\hat{E}_2 = \hat{E}_1 / \epsilon_r$ if the field is normal to the load. For other angles, $\hat{E}_1 / \epsilon_r < \hat{E}_2 < \hat{E}_1$. Thus, the shape of the load is an important factor affecting the internal field pattern and, hence, the temperature distribution. Some loads, depending on their dielectric properties and, particularly, on their shape, can even act

¹This is the usual situation, however, materials with magnetic loss can also be used.

as dielectric resonators in which case the fields within the load can be higher than outside (15,34).

About all that is done to improve heating uniformity with present techniques is to randomize the field patterns, or to move the load, to avoid hot and cold spots where the electric field is high and low respectively. Although thermal conductivity is an important factor in achieving uniform heating, its effect may not be significant if a load has poor thermal conductivity and/or if exposure times are short.

2.3 Circuit Efficiency in a Loaded Cavity

If the losses in the cavity walls and coupling structure are negligible, the problem of achieving high circuit efficiency reduces to that of achieving an impedance match between the microwave source, usually a magnetron, and the loaded cavity.

Figure 2.2 shows an equivalent circuit of a cavity loaded with a lossy dielectric load in the vicinity of resonance for one mode, say i .

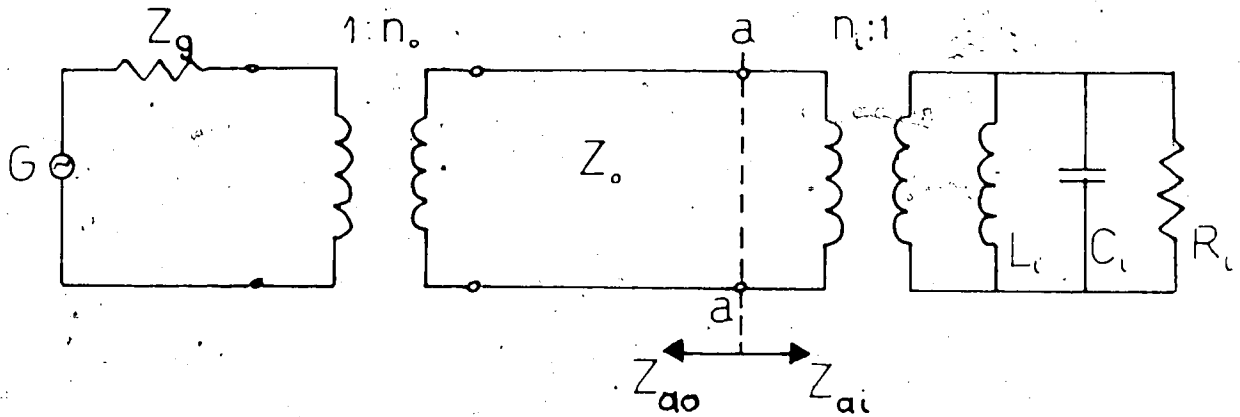

FIGURE 2.2 An equivalent circuit of a lossy cavity in the vicinity of resonance for mode i .

In Figure 2.2, Z_g is the output impedance of the magnetron, Z_0 the characteristic impedance of a lossless transmission line between the magnetron and the cavity, L_i and C_i are the equivalent inductance and capacitance of the cavity for mode i . Assuming negligible wall losses in the cavity, R_i accounts for the losses in the load. n_0 is the turns ratio of an ideal transformer representing the coupling between the magnetron and its external output structure. n_i is designed to satisfy the equation:

$$Z_0 = n_0^2 Z_g \quad (2.6)$$

n_i is the turns ratio of an ideal transformer representing the coupling structure between the transmission line and the loaded cavity for mode i .

In the vicinity of resonance for mode i :

$$Z_{ai} = n_i^2 \left[\frac{1}{R_i} + j \left(\omega C_i - \frac{1}{\omega L_i} \right) \right]^{-1} \quad (2.7)$$

For a given Z_0 the condition for maximum power transfer from the magnetron to the load is:

$$Z_{ai}^* = Z_{a0} \quad (2.8)$$

where: Z^* means conjugate of Z .

Z_{a0} is the impedance at plane a-a looking towards the magnetron.

Since Z_0 is usually resistive, Z_{a0} is also resistive and (2.8) is satisfied at resonance. In a lightly loaded multimode cavity and within a given bandwidth, the different modes are, in general, separated far enough from each other so that resonance is a condition for a local maximum of power transfer. A global maximum occurs for that mode which best approaches the condition,

$$Z_{a0} = n_i^2 R_i \quad (2.9)$$

For a more heavily loaded multimode cavity the resonance curves of the modes overlap and the equivalent

circuit of Figure 2.2 has to be modified by connecting in parallel, at the plane of Z_d , one ideal transformer with the corresponding parallel combination of L, C and R for each mode. Again the condition for a local maximum of power transfer is that Z_d be resistive, although in this case, the frequency at which this occurs may not coincide with any of the resonant frequencies of the individual modes. A global maximum of power transfer occurs at that frequency for which the condition given in equation (2.10) is best approached:

$$Y_{d0} = \sum_{i=1}^k \frac{1}{n_i^2 R_i} \quad (2.10)$$

where: k = number of modes considered.

An impedance match and hence highest circuit efficiency is achieved when equation (2.10) is satisfied. With present design techniques, however, this is rarely achieved because: a) for each loading condition the frequency at which (2.10) is satisfied is different, b) the bandwidth over which the magnetron tube can operate is quite narrow and c) the input impedance to the cavity changes cyclically due to the rotation of the mode-stirrer used to improve heating uniformity. In this way, condition (2.10) may be satisfied for some position of the mode-stirrer but not for others.

It seems clear that with present technology it is not feasible to operate a microwave oven at the maximum possible circuit efficiency for any given loading condition.

2.4 Microwave Power Sources

The CW magnetron is almost universally used as the microwave power source in microwave ovens. Its main advantages are:

- a.- High efficiency. In the range of 60% to 70% (26,29).
- b.- Ability to withstand a high load VSWR. Many modern magnetrons for microwave oven use can operate with load VSWR's of 6:1 (35,29) and some are claimed to be practically free of the sink region where moding occurs (35,29,36).
- c.- Ruggedness. Magnetrons have a simple physical structure and are suitable for low cost mass production.
- d.- Simple power supply requirements. The magnetron filament operates with a-c voltage and the anode voltage can be pure a-c, half-wave or full-wave rectified with no filtering or d-c. Most magnetrons for microwave oven use are now designed to operate from either a half or full-wave rectified supply with no filtering, often of the voltage doubler type.

Nevertheless, the CW magnetron also has its disadvantages. Being a self-excited tube, its output power, efficiency and frequency depend on the load impedance. The variation of frequency with load impedance is usually referred to as frequency pulling. The dependence of these parameters on the load impedance is described by the generator or Rieke diagram of the particular magnetron (37). Moreover, and as mentioned earlier, the magnetron is a narrowband tube which can operate within bandwidths of 15 MHz to 18 MHz, but for a given load, the output power is delivered within a couple of megahertz only. The frequency in this type of magnetron cannot be controlled, independent of other parameters, in a simple way.

In spite of these disadvantages the CW magnetron performs satisfactorily in today's microwave oven. However, if improvement of microwave oven performance is sought in techniques involving control of the microwave source, the conventional CW magnetron cannot be used.

2.5 Coupling Structures

The most common coupling structures used in microwave circuits are coaxial-line probes, magnetic loops and

apertures. In communication systems, for instance, these structures are used to couple one waveguide to another, a waveguide to a resonant cavity, a waveguide to an antenna, etc., but in all cases only one mode of propagation of the wave is used.

Coupling structures are used in microwave ovens to couple the magnetron or some form of transmission line to which the magnetron is connected, to the cavity. For a mode to actually exist in a microwave cavity three conditions must be met: the cavity must be capable of sustaining the particular mode, the source must operate at the mode frequency and the coupling structure must be capable of exciting it. In a microwave oven different modes fall within the bandwidth of the magnetron for different loading conditions, thus, the coupling structure is required to excite a wide variety of field patterns. Furthermore, it should provide a good impedance match to the magnetron under all loading conditions, if consistently high circuit efficiency is to be achieved.

Although for some time it was thought better to couple the magnetron directly to the cavity, often via its own output probe, it has been found that broadband coupling of the magnetron to a waveguide and of the waveguide to the cavity gives better results (38). Many types of coupling

structures have been proposed (16,38). However, only a few are commonly used. Figure 2.3 shows two typical ones.

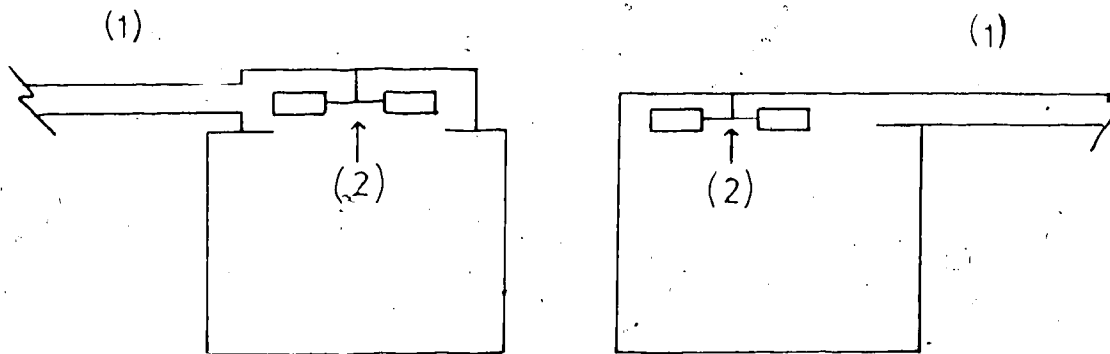

(1) Waveguide to magnetron.

(2) Mode-stirrer.

FIGURE 2.3 Schematic representation of two typical coupling structures used in microwave ovens.

A coupling structure which has been shown to be superior, at least to probes and loops, in coupling to a large number of modes is the slow-wave coupler developed by Johnston (39), but further work is required to compare its performance with that of coupling structures of the aperture type.

2.6 Turntables and Mode Stirrers

Turntables and mode-stirrers are two devices used to improve heating uniformity in microwave ovens. The turntable

rotates the load to average out the heating effect of a particular electric field pattern but, although it appears to be reasonably successful in improving heating uniformity (19), it is not in widespread use.

The mode-stirrer is by far the most commonly used device for improving heating uniformity. A large variety of designs have been suggested (16,17) but the type usually found in microwave ovens takes the form of a metal fan which revolves at a low speed (≈ 1 Hz). Propulsion is achieved either with an electric motor or by directing an air current to the mode-stirrer, which is normally placed in front of the coupling aperture.

As opposed to the turntable action, a mode-stirrer alters the field patterns to average their heating effects in the load. The action of the mode-stirrer can be interpreted in the following ways, which need not be mutually exclusive:

a.- As the mode-stirrer rotates, the resonant frequency of a number of modes are shifted cyclically, and the modes are excited when their resonant frequency coincides with that of the magnetron.

b.- The frequency pulling effect caused by the varying load impedance seen by the magnetron, broadens the bandwidth over which the power is delivered, thus, a

larger number of modes are excited.

c.- If the flow of microwave energy into the cavity is assumed to be similar to the propagation of a light beam, the mode-stirrer can be considered a moving mirror which reflects the energy in all directions. In this interpretation, improved heating uniformity is achieved by "illuminating" the load with microwave energy from as many different directions as possible.

That mode-stirrers partially improve heating uniformity in a microwave oven has been shown (40,41) and is a widely accepted fact, but because the action of mode-stirrers is so complex, their design remains more an art than a science. The results of some experiments aimed at a better understanding of this device are reported in chapter 6.

It is believed that the lack of control of the operation of microwave ovens seriously limits further improvement of their performance. Consequently, the potential of controlling the frequency of the microwave source is an approach which is investigated in this thesis.

CHAPTER 3

MEASUREMENT AND PREDICTION OF TEMPERATURE PATTERNS

The theoretical prediction of temperature patterns in a low profile load is investigated in this chapter. The objective is to establish whether or not a simple mathematical model is sufficiently accurate to predict temperature patterns, when the cavity is excited in a known mode. The technique could provide a design aid for advanced microwave ovens.

3.1 Measurement of Temperature Patterns

To evaluate the performance of microwave ovens, insofar as their ability to heat a load uniformly is concerned, several techniques have been proposed (41,42,44,45). However, no consensus has yet been reached as to which gives a better prediction of performance, and is practical to use in terms of reproducibility. The techniques which have been developed include: heating of actual foods, simulated foods, sheet loads with temperature sensitive indicators and separate water samples.

When heating foods, usually a sensory evaluation is done by a group of persons. With simulated foods,

temperature profiles are measured and recorded. Although these techniques approach the real situation in a loaded oven better than sheet loads or separate water samples, they are not easy to reproduce. Because of the large variety of foods that can be processed in a microwave oven, the conclusions drawn from a specific test do not necessarily apply to all foods.

The other techniques, which are sheet loads with temperature sensitive indicators or separate water samples, are used to "map" the energy distribution in the oven cavity. As temperature indicators in sheet loads, egg white has been used (43,44). The egg white coagulates when heated, thus giving an indication of the regions where the electric field intensity is highest. Liquid crystals have also been used for obtaining electric field patterns (46). They have the advantage of giving an indication over a range of temperatures, changing from black to brown, green and blue for, typically, a 4 to 6°C temperature rise.

When using water samples to map the energy distribution of a cavity, two approaches have been used. In the first, samples of the same size are placed in a number of positions and their temperature measured after equal exposure times. In the second, an array of small samples is exposed and the temperature of each of the samples measured (31).

The implicit assumption, in both techniques, is that the energy distribution in the loaded cavity is not significantly different from that in the empty or lightly loaded cavity. To support this assumption, there is evidence of reasonably good correlation between energy distribution maps obtained with these methods and temperature profiles in some foods (42).

3.2 Prediction of Temperature Patterns

3.2.1 Introduction

Little is known of the relationship between energy patterns in an empty or lightly loaded cavity, and the corresponding temperature patterns in actual loads. The conventional approach taken to obtain uniform heating is to randomize the fields in the cavity as much as possible. The mode-stirrer is used for this purpose and new designs are constantly being patented (16,17); however, success has been limited. Furthermore, with this approach it is not possible to obtain predetermined temperature patterns, which may not be necessarily uniform. Non uniform heating in domestic microwave ovens can be, in many cases, dealt with by occasionally changing the position of the food during the cooking process. The problem is more serious when heating

prepackaged foods and in ovens for institutional use.

Some authors, Pritchard (47), Staats (48) and Saad (49) have proposed the excitation of a few modes to obtain good heating uniformity, as opposed to exciting a large number of modes and using mode-stirrers. These modes are selected from those which can be excited in a given cavity within the allowed operating bandwidth. Pritchard's approach was partially incorrect, as has been shown by Mackay (50). Staats and Saad do not explain why the modes they select should give better uniformity; no experimental data is given by the authors.

It is important to establish that the correlation sought here between theoretical results and experimental data is of a qualitative nature only. The interest is in correlating patterns rather than actual temperatures.

3.2.2 Experimental Procedures

A simple load was investigated. It consisted of a square of approximately 30 by 30 cm of a lossy sheet of dielectric material¹ ($\epsilon_r = 16 - j16$), to which a square sheet (of the same dimensions) of liquid crystals was glued. The

¹Carbon filled fiber commonly used in waveguide attenuators.

liquid crystals used change from black (30°C) through brown, to green and blue at (36°C). Total thickness was 1.3 mm.

The reference system for a cavity, used in this thesis, is shown in Figure 3.1.

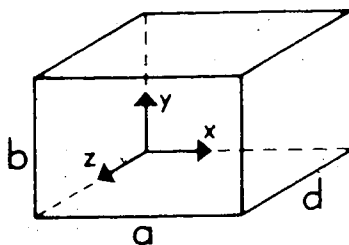

FIGURE 3.1 Reference system for a cavity.

The dimensions of the cavity used in these experiments were: $a=52$ cm, $b=23$ cm and $d=50$ cm. The cavity was made of 1 cm thick aluminum plate. Four positions of the load were chosen so that they would overlap each other, as shown in a top view of the cavity in Figure 3.2.

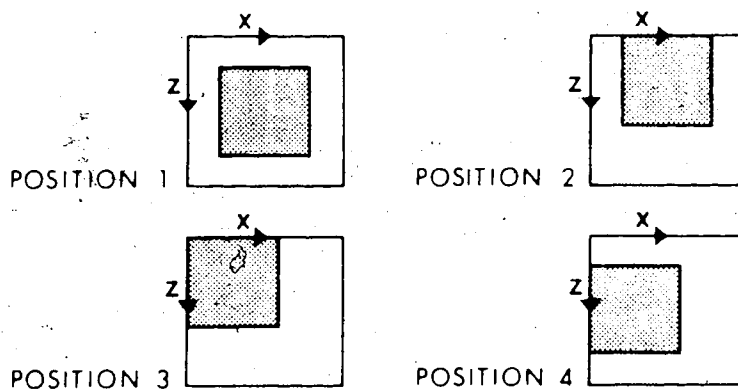

FIGURE 3.2 The four load positions studied.

In all four positions the height of the load, from the bottom of the cavity, was 5 cm.

The two modes selected for the investigation were the 211 and the 112. The variation in resonant frequency of each mode, with the position of the load, was negligible, thus, their resonant frequencies were taken to be 932 MHz and 917 MHz respectively, as calculated for an unloaded cavity. These modes were chosen because they are well separated from each other in the frequency spectrum and, because they can be TE, TM or both.

The coupling structure was a simple probe penetrating at the top of the cavity and parallel to the Y axis. Its length and location were chosen to obtain good coupling for all load positions. For the 211 mode the probe was located at $X=10.5$ cm and $Z=25$ cm. For the 112 mode the coordinates were $X=26$ cm and $Z=9$ cm. The minimum return loss achieved was 13 dB (95% of the power is absorbed by the load).

The power source was a laboratory microwave generator with frequency variable from 500 MHz to 1000 MHz and power variable from 0 to 50 W.

The procedure to obtain the temperature patterns was the following: the output power of the generator was set at

30 W. The load was placed in one of the four positions and exposed for times ranging from 20 to 30 s. At the end of the exposure the load was quickly placed on a jig and a picture taken with a Polaroid camera. This procedure was the same for all positions and for both modes. The energy deposited in the load could not be the same in all cases, because, depending on the size of the area where the power was dissipated, the temperature could fall outside the temperature range of the liquid crystals. Thus, the exposure time was somewhat different for each pattern in order to make the experimental and theoretical results comparable.

3.2.3 Theoretical Analysis

The temperature rise at any point in a lossy dielectric exposed to electromagnetic radiation is given by equation (2.5):

$$\Delta T = \frac{K f \epsilon_n''}{C_p t} t |\hat{E}|^2 \quad (25)$$

From this equation it is seen that for a homogeneous load which has an ϵ_n'' reasonably independent of temperature and for a given mode (constant frequency), ΔT at every point in the load is proportional to t and to $|\hat{E}|^2$ at that

point. This, of course, assumes that the thermal conductivity of the load is zero. This was not the case for the load used in the experiments, but since it was quite low and since the experiments involved short times, as a first approximation ΔT can be considered to be proportional to t and $|\hat{E}|^2$ only.

If the field patterns in the empty cavity are not significantly altered by the load, the temperature patterns obtained experimentally should closely resemble the patterns of $|\hat{E}|^2$, when \hat{E} is calculated from the equations for the empty cavity. Since the modes chosen could be TE or TM, the possibility of both being excited simultaneously had to be considered.

The model used to calculate \hat{E} is the following: assume a rectangular waveguide of dimensions a and b along the X and Y axis respectively, in which a TE mode is propagating. The field component of this mode in the direction of propagation, Z , is given by (32),

$$H_z = A \cos \frac{l\pi x}{a} \cos \frac{m\pi y}{b} e^{-j\beta z} \quad (3.1)$$

where: β = phase constant

If a short is placed in the waveguide, standing waves are set up. If another short is placed at a distance d from the

first one, where H_z is zero, it can be shown that H_z inside the cavity thus formed, is given by:

$$H_z = -2jA \cos \frac{l\pi x}{a} \cos \frac{m\pi y}{b} \sin \frac{n\pi z}{d} \quad (3.2)$$

From this equation all other field components for the TE mode can be calculated.

For a TM mode the field component in the direction of propagation is given by,

$$E_z = B \sin \frac{l\pi x}{a} \sin \frac{m\pi y}{b} e^{-j\beta z} \quad (3.3)$$

According to the same model, E_z inside the cavity is given by,

$$E_z = 2B \sin \frac{l\pi x}{a} \sin \frac{m\pi y}{b} \cos \frac{n\pi z}{d} \quad (3.4)$$

where d is the distance between the short and a plane where $\partial E_z / \partial z = 0$. From this equation all other field components for the TM mode can be calculated.

The boundary conditions between two dielectrics require that the tangential electric field and the normal electric flux density be continuous at the boundary. If dielectric 1

is air and dielectric 2 has a relative permittivity ϵ_r' , the normal electric field at the boundary inside dielectric 2 is given by,

$$\hat{E}_2 = \frac{\hat{E}_1}{\epsilon_r'} \quad (3.5)$$

Since the load used in this investigation is a thin sheet in the XZ plane and ϵ_r' is $\gg 1$, according to (3.5), the contribution of E_y to heat the load is negligible. Thus, the only field components that significantly contribute to heat the load are: E_x for the TE mode, which will be called E_{x1} and, E_z and E_x for the TM mode. The latter will be called E_{x2} . The expressions for these fields are (32):

$$E_{x1} = \frac{2\omega\mu_0 A}{k_c^2} \left(\frac{m\pi}{b}\right) \cos \frac{l\pi x}{a} \sin \frac{m\pi y}{b} \sin \frac{n\pi z}{d} \quad (3.6)$$

$$E_z = 2B \sin \frac{l\pi x}{a} \sin \frac{m\pi y}{b} \cos \frac{n\pi z}{d} \quad (3.7)$$

$$E_{x2} = -\frac{2B}{k_c^2} \left(\frac{n\pi}{d}\right) \left(\frac{l\pi}{a}\right) \cos \frac{l\pi x}{a} \sin \frac{m\pi y}{b} \sin \frac{n\pi z}{d} \quad (3.8)$$

where: $k_c^2 = 2\pi f_c / c$

3.2.4 Computations and Results

A computer program was written to calculate the square of the total electric field at 441 points in the load, in each position. The following five cases were analyzed: the mode excited was a TE, a TM, TE and TM in time phase, TE and TM 90° out of time phase and, TE and TM 180° out of time phase. The square of the total electric field for these cases are:

$$|\hat{E}_T|^2 = |E_{x1}|^2 \quad (3.9)$$

$$|\hat{E}_T|^2 = |E_{x2}|^2 + |E_z|^2 \quad (3.10)$$

$$|\hat{E}_T|^2 = |E_{x1} + E_{x2}|^2 + |E_z|^2 \quad (3.11)$$

$$|\hat{E}_T|^2 = |E_{x1}|^2 + |E_{x2}|^2 + |E_z|^2 \quad (3.12)$$

$$|\hat{E}_T|^2 = |E_{x1} - E_{x2}|^2 + |E_z|^2 \quad (3.13)$$

The computer output was a square array of 441 values corresponding to the 441 points in the load. The printout was then photographically reduced to the same size of the Polaroid pictures for direct comparison. In all cases the values of $|\hat{E}_T|^2$ were normalized to a maximum value of 10 before printing. Contours were drawn enclosing values of $|\hat{E}_T|^2 \geq 7.0$, $7.0 > |\hat{E}_T|^2 \geq 5.0$, and $5.0 > |\hat{E}_T|^2 \geq 3.0$. This division was selected to match one of the pictures and then applied

for all the other patterns.

When analyzing those cases where the TE and TM modes were excited, several combinations of constants A and B were tried. The best results were obtained for $B/A \approx 380$. The results are shown in Figures 3.3 through 3.5 for the 211 mode and Figures 3.6 through 3.9 for the 112 mode. Temperature ranges are shown with different densities of cross-hatching; the higher the density the higher the temperature. All other theoretical results bore no resemblance to the experimental results. A few exceptions are explained in the discussion.

3.2.5 Discussion

The model assumes that the fields in the empty cavity are not perturbed by the load; however, even in the empty cavity, the fields cannot be expected to be identical to the theoretical ones, since the theory assumes perfectly conducting walls, exact dimensions and no input or output port. The model neglects the thermal conductivity of the load and the unavoidable nonuniformity of the thermal resistance between the load itself and the liquid crystals sheet. Other sources of inaccuracies are the limited temperature range of the liquid crystals and the low resolution obtained with 441 points in a 30 cm square area.

POSITION 1

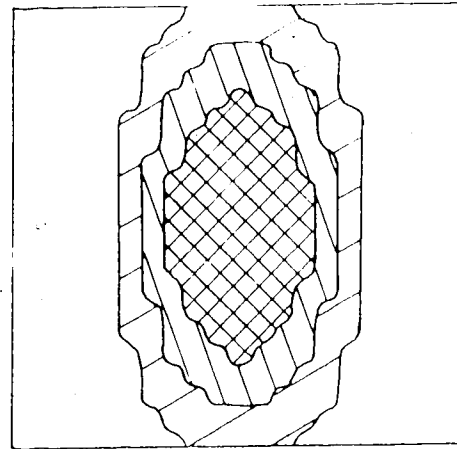
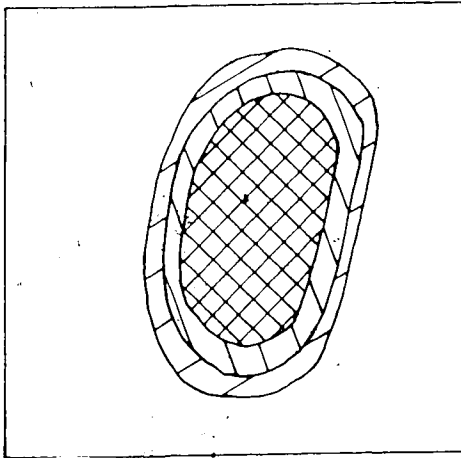

$$|E_T|^2 = |E_{x1}|^2$$

POSITION 2

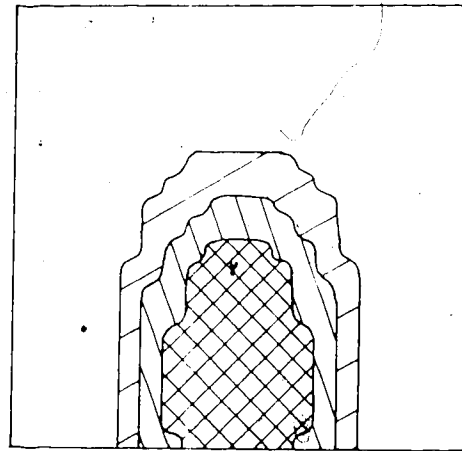
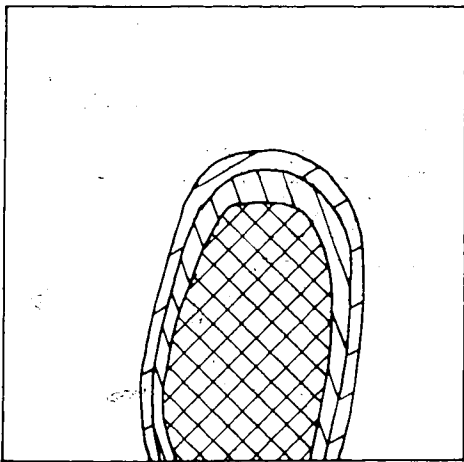

$$|E_T|^2 = |E_{x1}|^2$$

FIGURE 3.3 Mode 211. Temperature patterns for positions 1 and 2. Experimental patterns are at left.

POSITION 3

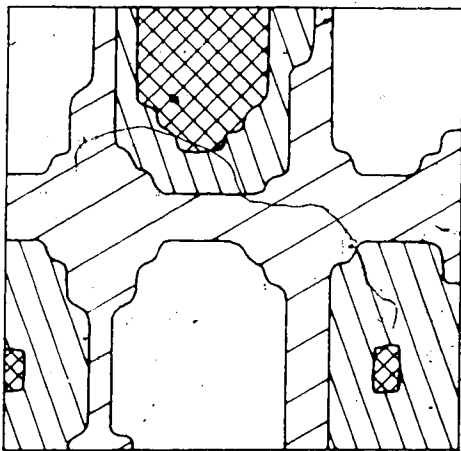
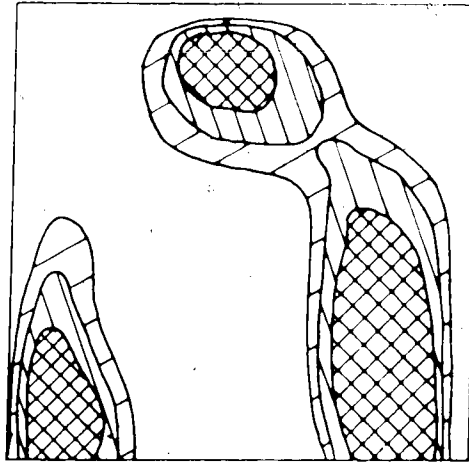

$$|E_T|^2 = |E_{x1}|^2 + |E_{x2}|^2 + |E_z|^2$$

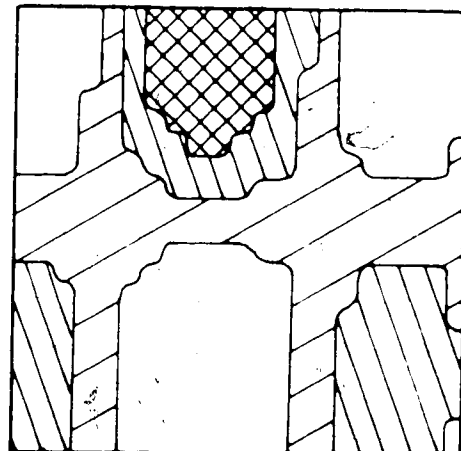

$$|E_T|^2 = |E_{x1} - E_{x2}|^2 + |E_z|^2$$

FIGURE 3.4 Mode 211. Temperature pattern for position 3. Experimental pattern is at the top.

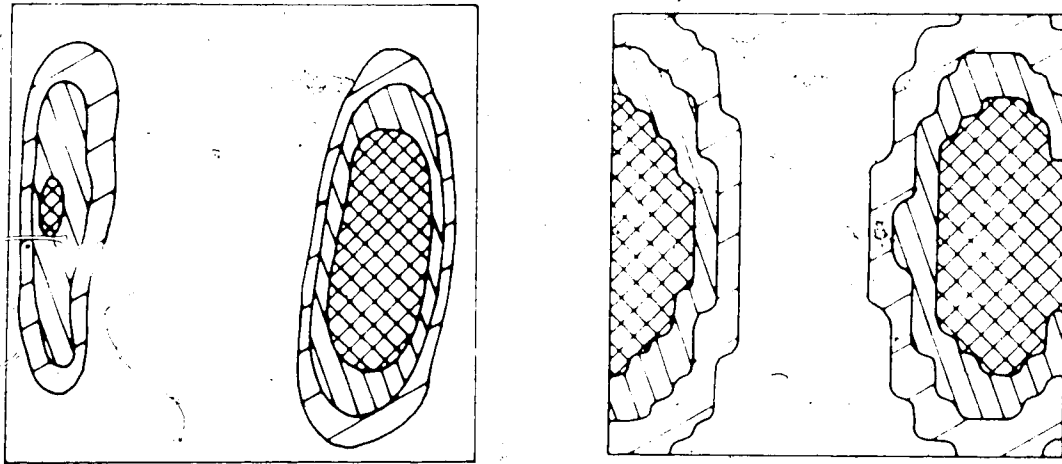

$$|E_T|^2 = |E_{x1}|^2$$

FIGURE 3.5 Mode 211. Temperature pattern for position 4. Experimental pattern is at the left.

POSITION 1

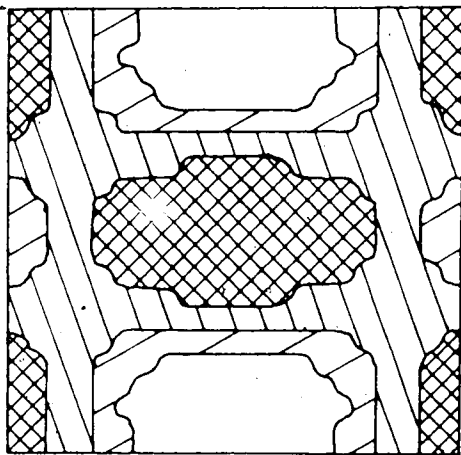
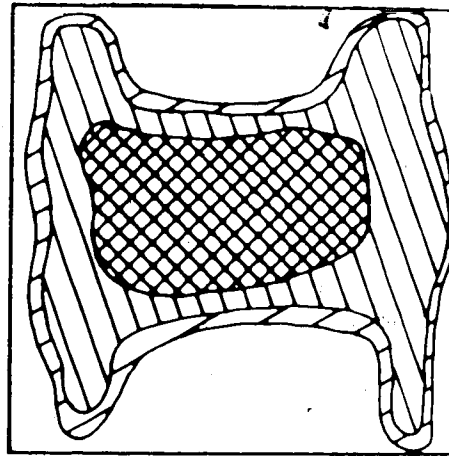

$$|E_T|^2 = |E_{x1}|^2 + |E_{x2}|^2 + |E_z|^2$$

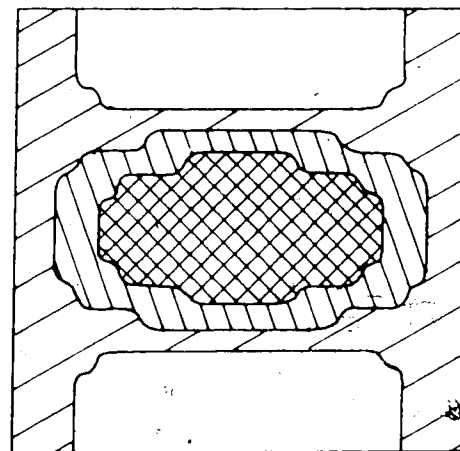

$$|E_T|^2 = |E_{x1} + E_{x2}|^2 + |E_z|^2$$

FIGURE 3.6 Mode 112. Temperature pattern for position 1. Experimental pattern is at the top.

POSITION 2

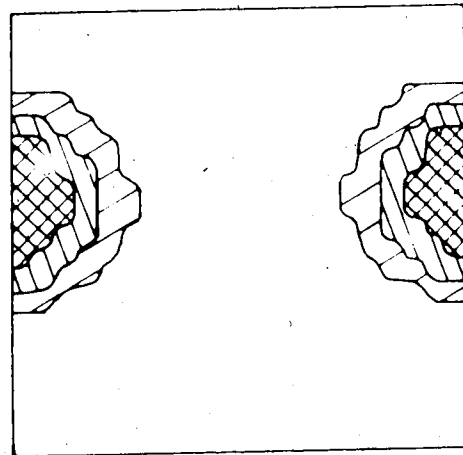
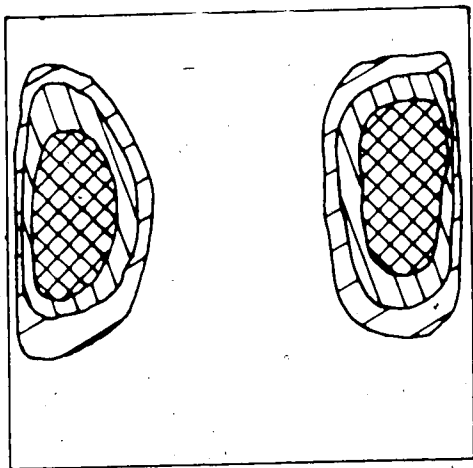

$$|E_T|^2 = |E_{x1}|^2$$

FIGURE 3.7 Mode 112. Temperature pattern for position 2. Experimental pattern is at the left.

POSITION 3

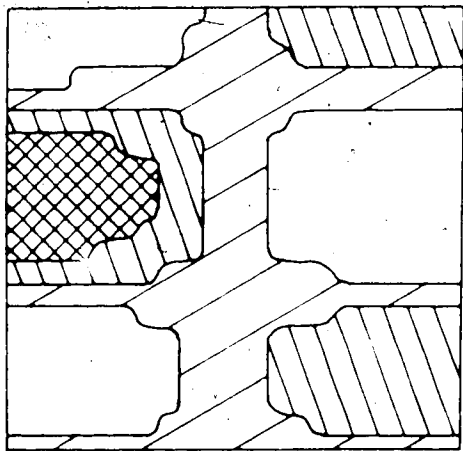
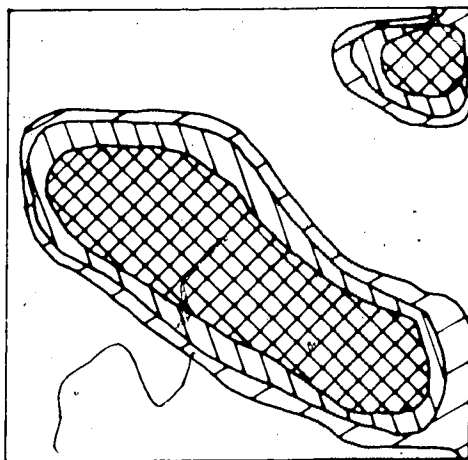

$$|E_T|^2 = |E_{x1}|^2 + |E_{x2}|^2 + |E_z|^2$$

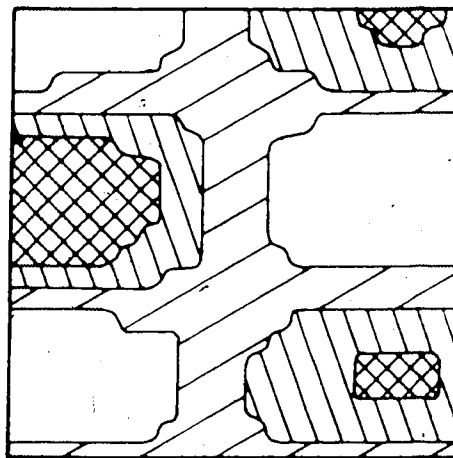

$$|E_T|^2 = |E_{x1} - E_{x2}|^2 + |E_z|^2$$

FIGURE 3.8 Mode 112. Temperature pattern for position 3. Experimental pattern is at the top.

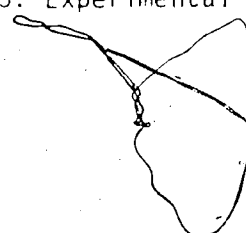

POSITION 4

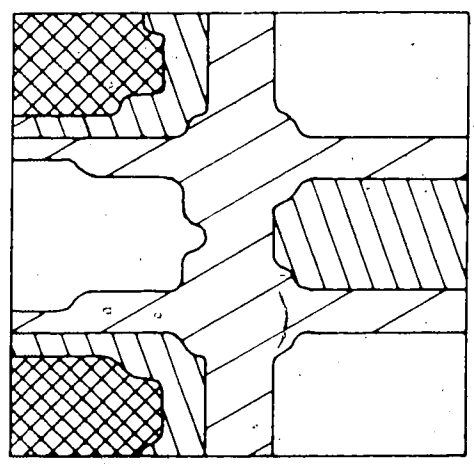
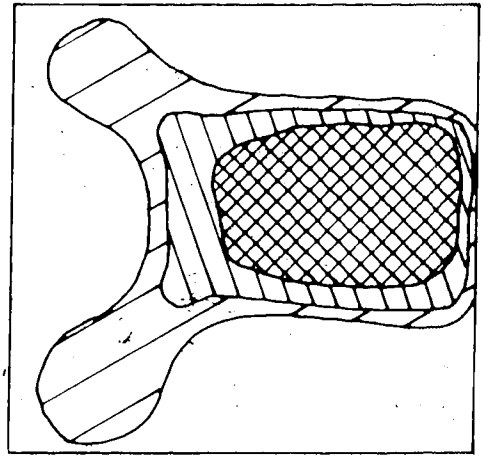

$$|E_T|^2 = |E_{x1}|^2 + |E_{x2}|^2 + |E_z|^2$$

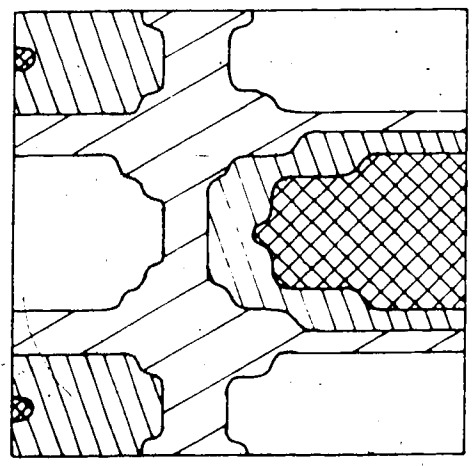

$$|E_T|^2 = |E_{x1} + E_{x2}|^2 + |E_z|^2$$

FIGURE 3.9 Mode 112. Temperature pattern for position 4. Experimental pattern is at the top.

Considering the simplicity of the model and the sources of error described above, the correlation between measured and calculated patterns is, in most cases, quite remarkable.

The pattern in position 3 for the 211 mode and those in positions 1, 3 and 4 for the 112 mode, could only be correlated to those where the TE and TM modes were considered to be excited simultaneously. However, none of the three phase relationships analyzed (only the best two are shown in the figures) gives as good a correlation as that obtained for the other positions. One possibility is that the actual phase difference between the modes is different from those analyzed. Another is that this phase difference may vary with time. It would be difficult to determine how it varies with time, since the way in which the TM mode is excited together with the TE mode for some loading conditions, is very difficult to establish.

The results of this investigation show that if a mode can only be a TE or TM, the calculated temperature patterns would predict with reasonable accuracy, and no ambiguity, actual temperature patterns in a low profile load. For microwave heating systems in the lumber, textile and paper industries, for instance, cavities could be designed with an a priori knowledge of the modes that are required.

For loads like food, theoretical calculations of temperature distributions have been done by Ohlsson (20,22) assuming a plane wave incident on slabs of food approximated as infinite plates. The model developed in this chapter, if used in conjunction with a suitable model of heat transfer, should give accurate temperature distributions in finite loads in a microwave oven.

3.3 Temperature Pattern Tailoring

Using the same load and cavity as those used in the work of the previous section, a few experiments were performed to study the superposition of temperature patterns. Two microwave sources were used to excite two different modes. A Polaroid picture was taken of the temperature pattern for each mode excited separately. Both modes were then excited simultaneously and a picture taken. The latter was an almost perfect superposition of the previous two. This, however, is to be expected since both sources operate independent of each other and at different frequencies. The same result would be expected if only one source were used, but its frequency changed to excite both modes sequentially. Results of pattern superposition using this technique will be shown in chapter 5.

These results suggest the possibility of tailoring temperature patterns by exciting suitable modes at suitable power levels. The technique developed in section 3.2 can be a valuable aid in determining these modes and power levels.

CHAPTER 4

MICROWAVE TO HEAT CONVERSION EFFICIENCY

Microwave ovens save energy due to their high conversion efficiency, however, there is still considerable room for improvement. The main purpose of this chapter is to determine conversion efficiencies in an experimental cavity and in a typical commercially available domestic oven, for comparison with conversion efficiencies which can be achieved using a new technique developed in chapter 5.

4.1 Overall Efficiency of Microwave Ovens

The overall efficiency of a microwave oven can be divided into the following partial efficiencies:

- a.- Power supply efficiency.
- b.- Magnetron efficiency.
- c.- Microwave to heat conversion efficiency or circuit efficiency. This is an absolute value which is calculated as the ratio of power absorbed by the load to power delivered by the magnetron.

The overall efficiency of a microwave oven is calculated by measuring the power drawn by the system from the AC power line and the corresponding power absorbed by a large load,

usually, 1 to 2 l of water (21,26)¹. Typical overall efficiencies for domestic microwave ovens are in the 40% to 50% range (25,19). If a microwave oven has an overall efficiency of 45%, for instance, taking typical efficiencies for the power supply and magnetron of 95% and 65% (26), respectively, a circuit efficiency of 73% results.

From figures it is clear that substantial improvement in overall efficiency can only be achieved by improving the magnetron and the circuit efficiencies. The efficiency of CW magnetrons in the 0.7 kW to 2 kW range was, on the average, 60% in 1967 (52). Today, some production magnetrons show efficiencies of approximately 65% (35) and up to 69% has been reported (53). Further improvement will require a substantial research and development effort and, another 5% to 10% increase in magnetron efficiency cannot be expected for several years. Thus, in the short term, the overall efficiency of a microwave oven can only be improved by improving the circuit efficiency and, as shown in chapter 1, a circuit efficiency figure of 95% is a realistic goal.

The use of large water loads is the most common

¹For some standard tests (e.g. loads for leakage measurements) 275±25 ml of water are stipulated. The same volume of corn oil has also been suggested as a "standard load".

procedure to calculate the Maximum Power Available to the Load (MPAL) and the overall efficiency. The assumption is that for an average size microwave oven, 1 to 2 l of water is a large enough load to absorb all the microwave power that is available in the cavity. An overall efficiency figure based on such a load, however, is somewhat misleading since it says very little about the efficiency that can be expected for smaller, more realistic loads (a bowl of soup, for instance, is about 250 ml). At the same time it does not take into account the variations of efficiency with varying positions of the load inside the cavity. Finally, due to the different size of oven cavities, it is more suitable to use a filling factor F (ratio of load to cavity volume, 33) rather than load volumes when determining the MPAL or efficiencies.

4.2 Circuit Efficiency of Microwave Ovens

The experiments reported here were aimed at investigating the following in a microwave oven:

- a.- Variation of circuit efficiency with load volume.
- b.- Efficiency dispersion. In the context of this thesis, this expression defines the variation of circuit efficiency for a load, as a function of its position in the cavity.
- c.- Effect of the mode-stirrer on circuit efficiency

and efficiency dispersion.

d.- Effect of source bandwidth on efficiency and efficiency dispersion.

The experiments were performed in an experimental cavity and in a typical commercially available domestic oven.

4.2.1 General Experimental Procedures

Experimental procedures which are common to all experiments performed are described here. Particular aspects will be described later for each experiment. The following 5 filling factors were studied: 0.05%, 0.1%, 0.5%, 1.0% and 1.5%. Six positions were determined in a pseudo-random way, in the sense that three levels above the bottom of the cavity were chosen; 0 cm, 2.5 cm and 7.5 cm, and 2 positions were randomly selected at each level. At each position, the power absorbed by each of the 5 loads was measured. The load was water in styrofoam cups provided with a styrofoam lid to minimize heat losses. The dimensions of the cups used for the different filling factors are given in Figure 4.2 and are in centimeters. Preliminary tests² were performed to observe how the absorbed power varied when a measurement was

²For each filling factor and each position, the preliminary tests were repeated ten times. The results indicated considerable care was required for heating small loads. For high filling factors fewer tests were necessary for each load position.

repeated. Since larger variations were observed for the smaller loads, the values that appear on the graphs are the average of three measurements for the 0.05% and 0.1% filling factor loads, two for the 0.5% and 1.0% loads and one for the 1.5% loads. Exposure times were selected to yield a temperature rise between 10 °C and 20 °C, and all temperatures were measured with a thermocouple. The power absorbed by the load was computed from equation (2.4), with $C = 4.186$ [Joules/°C g], $\rho = 1$ [g/cm³], time in seconds and temperature in °C, thus, obtaining the absorbed power in watts. It is important to clarify, at this point, that the efficiencies that appear in the following graphs are not absolute circuit efficiencies. Unless otherwise specified, they are normalized to the largest power absorbed by a load in each experiment. All experiments were done within the 2,450 MHz ISM band.

4.2.2 Circuit Efficiency of Experimental Cavity Using a Conventional Magnetron

The experimental cavity is the same as the one used in the work of chapter 3 of this thesis. The coupling structure was an S-band waveguide connected to one of the side walls, at a location that was chosen for convenience. The waveguide could be rotated in 30° steps and, for this experiment, it was set at an angle of 60° between its broad side and the

horizontal. This angle was chosen because it yielded the largest number of modes excited in a 100 MHz bandwidth. Seven were strongly coupled (return loss greater than 10 dB). The microwave generator was an XL-81³ American Microwave Inc. CW magnetron, rated at 1 kW output power and operated from a full-wave voltage doubler power supply. The output power could be varied from about 50 W to 1 kW by means of a variable transformer.

The six positions of the load described in section 4.2.1 are, for the experimental cavity, those shown in Figure 4.1.

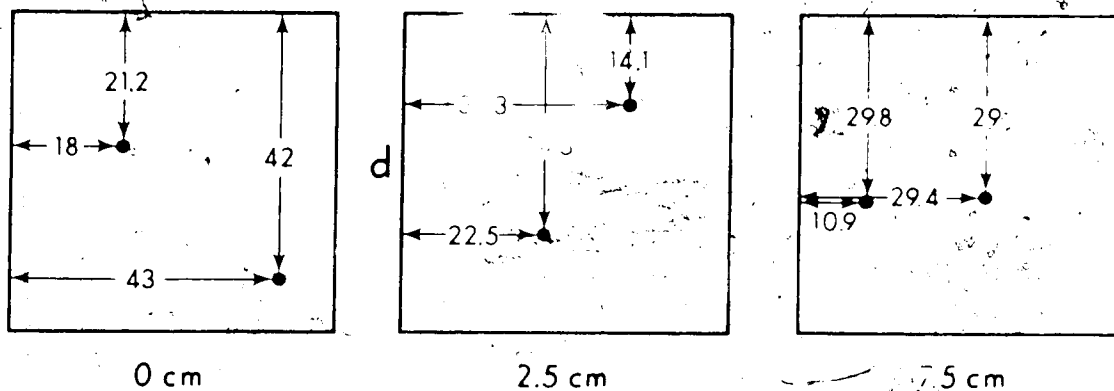

FIGURE 4.1 Load positions at each of the three levels chosen in the experimental cavity. $a = 52$ cm and $d = 50$ cm.

A total of 66 measurements (11 for each position) were made and the highest absorbed power obtained, after

³pulling figure: 16 MHz @ 1.5:1 VSWR.

57

averaging the repeated measurements, was used as the normalizing factor. In this way, a relative circuit efficiency was calculated.

Results

The results are shown in Figure .2. Highest, lowest and average relative circuit efficiencies for the different loads are shown. The actual volumes corresponding to the different filling factors for the experimental cavity are given on the horizontal axis. An extra measurement was taken for a 2.5% load, in order to verify that relative circuit efficiency (at least in this case) was not always an increasing function of volume.

The main feature of these results is the large efficiency dispersion for all filling factor loads.

4.2.3 Circuit Efficiency of a Domestic Microwave Oven

The microwave oven selected for this experiment can be considered typical of ovens in its class. Overall efficiency was found to be 44%. This figure compares very well with the average overall efficiency of 43% measured by Consumers' Research Magazine (19) for 10 domestic microwave ovens. Other typical characteristics are: the oven volume is 28.4

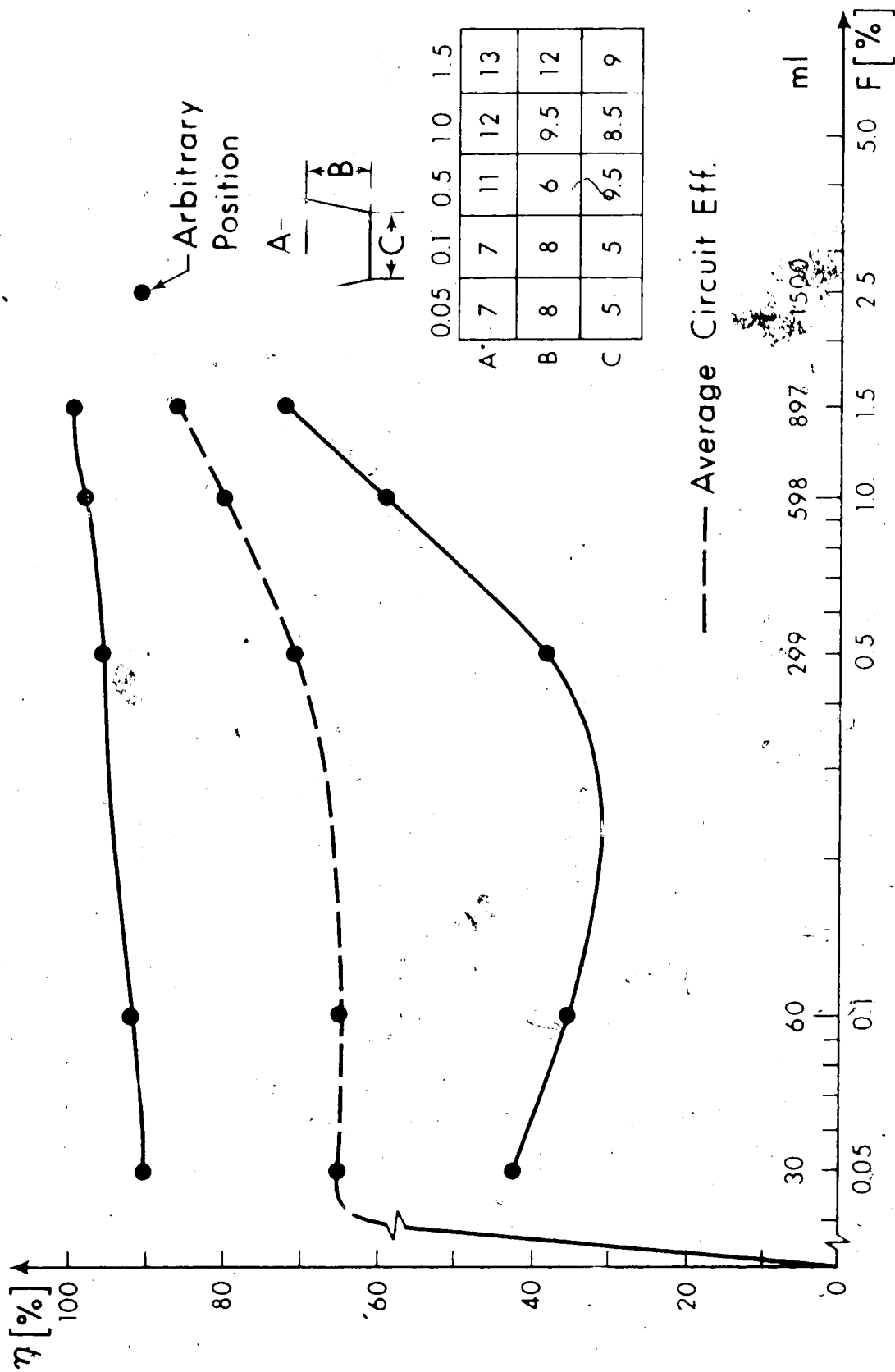

FIGURE 4.2 Relative circuit efficiencies for experimental cavity and conventional magnetron.

dm^3 (1 cu.ft.), a base load is provided by a lossy glass tray and a mode-stirrer is included.

The measurements performed in this oven were essentially the same as those of the previous section. The six load positions studied were, again, 2 at each of the 0 cm, 2.5 cm and 7.5 cm levels and are shown in Figure 4.3.

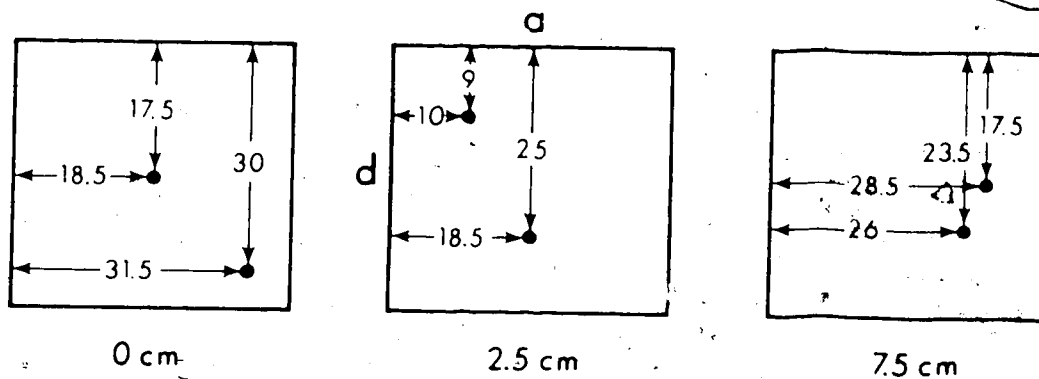

FIGURE 4.3 Load positions at each of the three levels chosen in the domestic microwave oven. $a = 37$ cm and $d = 35$ cm.

Results

Relative circuit efficiencies are shown in Figure 4.4. Before normalizing to the highest absorbed power measured, three extra measurements were performed at 2.5%, 5% and 6.4% filling factors. The power absorbed by the 5% load was used as the normalizing factor, since there was a negligible change in the power absorbed by larger loads.

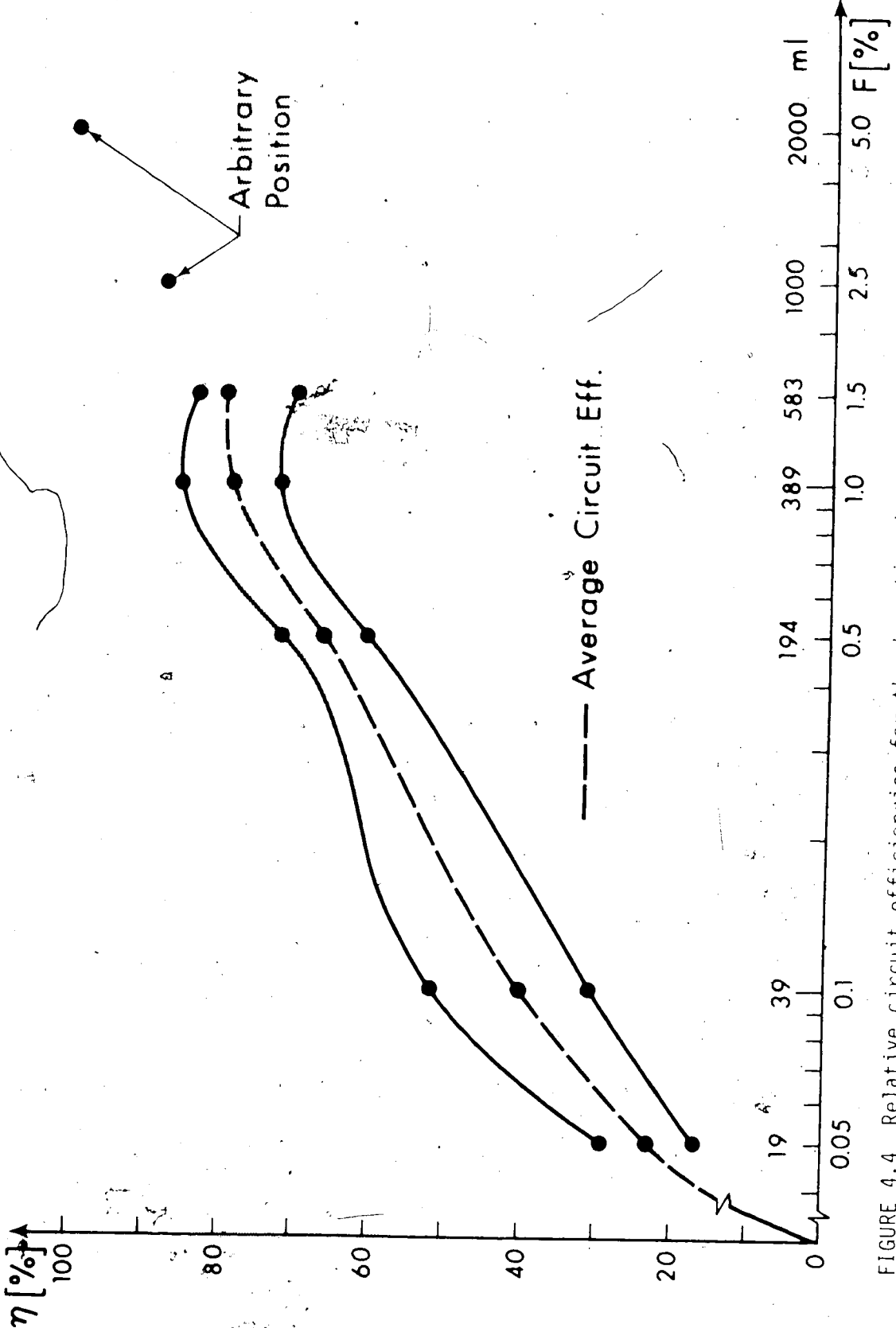

FIGURE 4.4 Relative circuit efficiencies for the domestic microwave oven.

The main features of these results are: a small efficiency dispersion and a rather steep decline in efficiency with decreasing filling factors. This steep decline in efficiency is most likely due to the base load provided by the glass tray.

4.2.4 Mode Stirrer Effect in Experimental Cavity Using a Conventional Magnetron

Circuit efficiency measurements were performed to determine the effect of a mode-stirrer on circuit efficiency and efficiency dispersion when the source is a conventional magnetron, and to establish whether these effects are due to perturbation of the fields in the cavity introduced by the mode-stirrer or to frequency pulling of the magnetron. The two phenomena were separated by using an isolator between the magnetron and the cavity.

Case 1. Effect of Mode Stirrer Without Isolator

The measurements performed are, essentially, the same as the previous ones in that load filling factors, load positions and method of calculating circuit efficiencies are the same.

The mode-stirrer was a 5 blade aluminum fan, 25 cm in diameter. It was located to yield maximum pulling of the magnetron frequency and was rotated with a jet of compressed air. Figure 4.5 shows the frequency spectrum of the magnetron measured in the input waveguide. Figure 4.5a is for the case of no isolator and no mode-stirrer, Figure 4.5b is for the case of no isolator with mode-stirrer, Figure 4.5c is for the case with isolator and no mode-stirrer and Figure 4.5d is for the case with isolator with mode-stirrer.

What is important to observe in these figures, is the considerable enhancement of the 3 dB bandwidth achieved with the mode-stirrer when there is no isolation of the magnetron. With an isolator there is a negligible effect of the mode-stirrer on the magnetron, and the 3 dB bandwidth is essentially the same as that when no mode-stirrer is used.

Results

The results for Case 1 are shown in Figure 4.6. The main features of these results are: the higher average circuit efficiency obtained without the mode-stirrer and the smaller efficiency dispersion obtained with the mode-stirrer. Of interest, also, is the fact that the rates of decline in efficiency for decreasing filling factors are very similar.

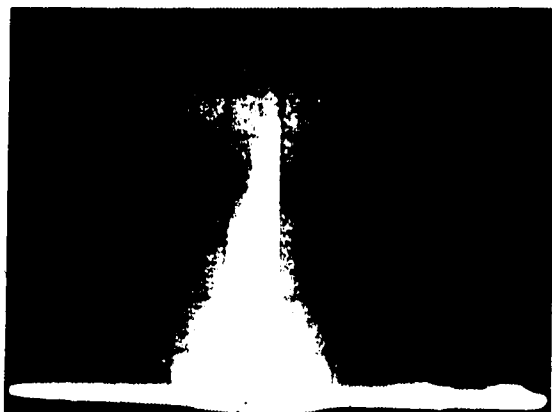

(a) Without isolator and without mode-stirrer.

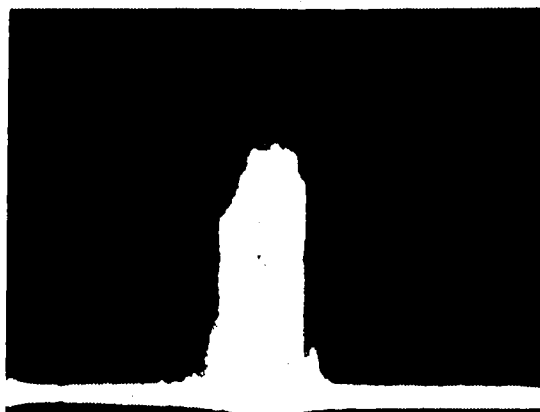

(b) Without isolator and with mode-stirrer.

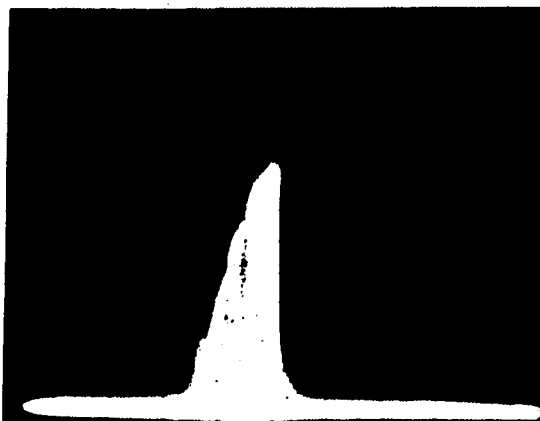

(c) With isolator and without mode-stirrer.

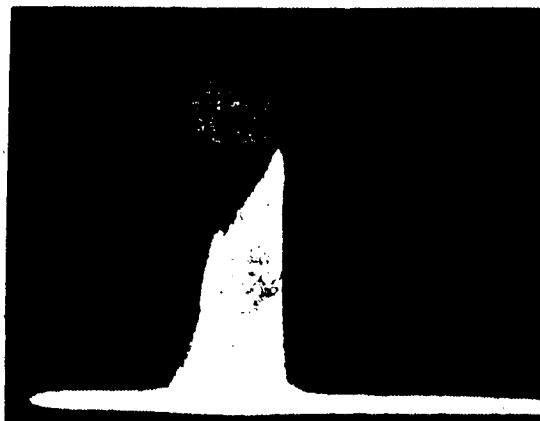

(d) With isolator and with mode-stirrer.

FIGURE 4.5 Frequency spectrum of conventional magnetron exciting the experimental cavity. Vertical scale: 10 dB/div, Horizontal scale: 10 MHz/div.

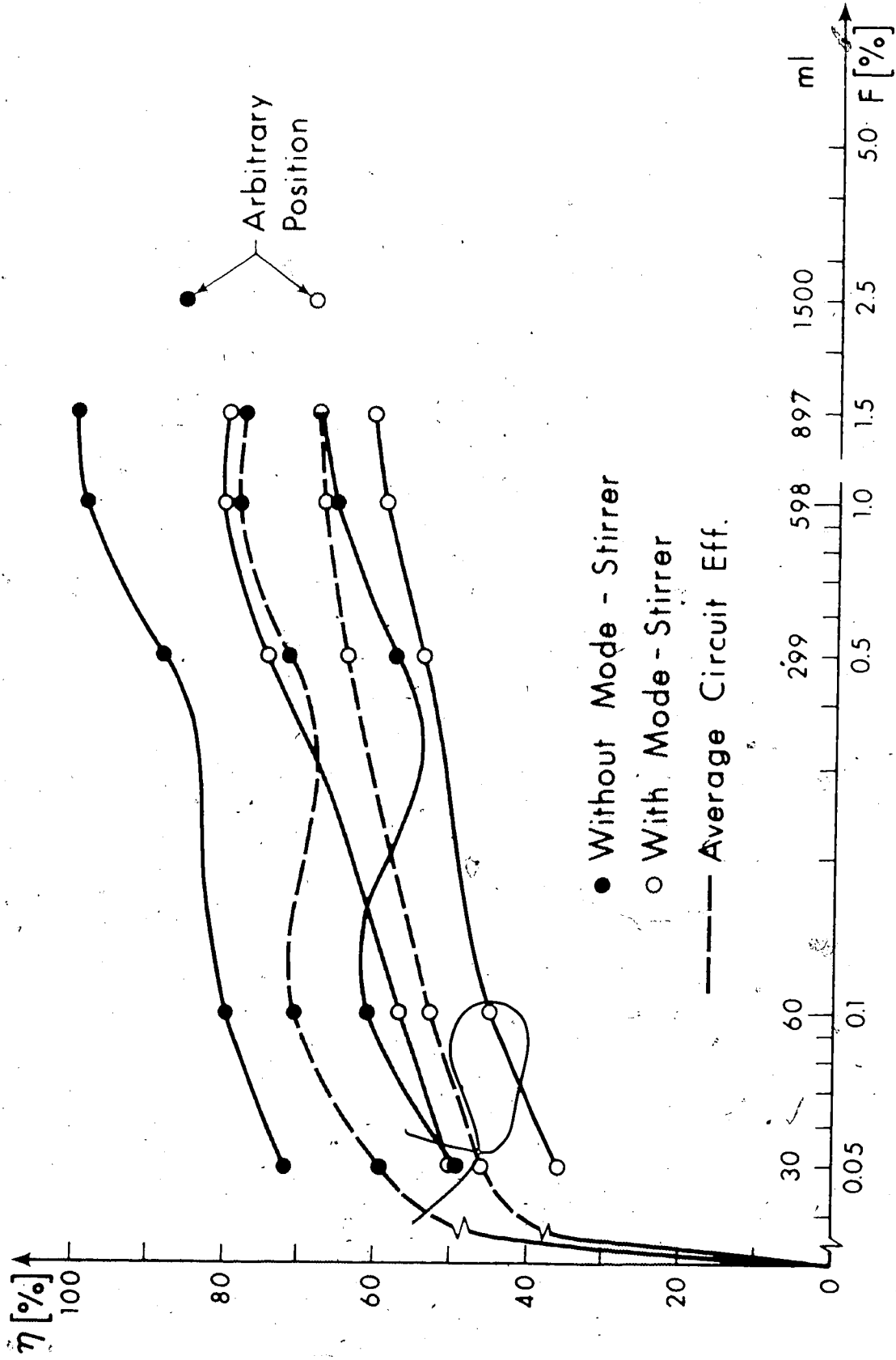

FIGURE 4.6 Relative circuit efficiencies for experimental cavity and conventional magnetron, without isolator.

Case 2. Effect of Mode Stirrer With Isolator

The measurements performed in this case are identical to those of case 1 except that an isolator was used between the magnetron and the cavity.

Results

The results for this case are shown in Figure 4.7. The main features of these results are: the large efficiency dispersion obtained without the mode-stirrer, the small efficiency dispersion obtained with the mode-stirrer, and the similar rates of decline in efficiency for decreasing filling factors. Comparing these results with those of Figure 4.6, it is clear that the small efficiency dispersion obtained in both cases with the mode-stirrer, is due to perturbation of the cavity fields rather than to frequency pulling.

4.3 Importance of Source Bandwidth on Circuit Efficiency

What is the minimum bandwidth required to satisfactorily operate a microwave oven? This is a very important question which has as yet not been answered or adequately investigated. This question acquires special

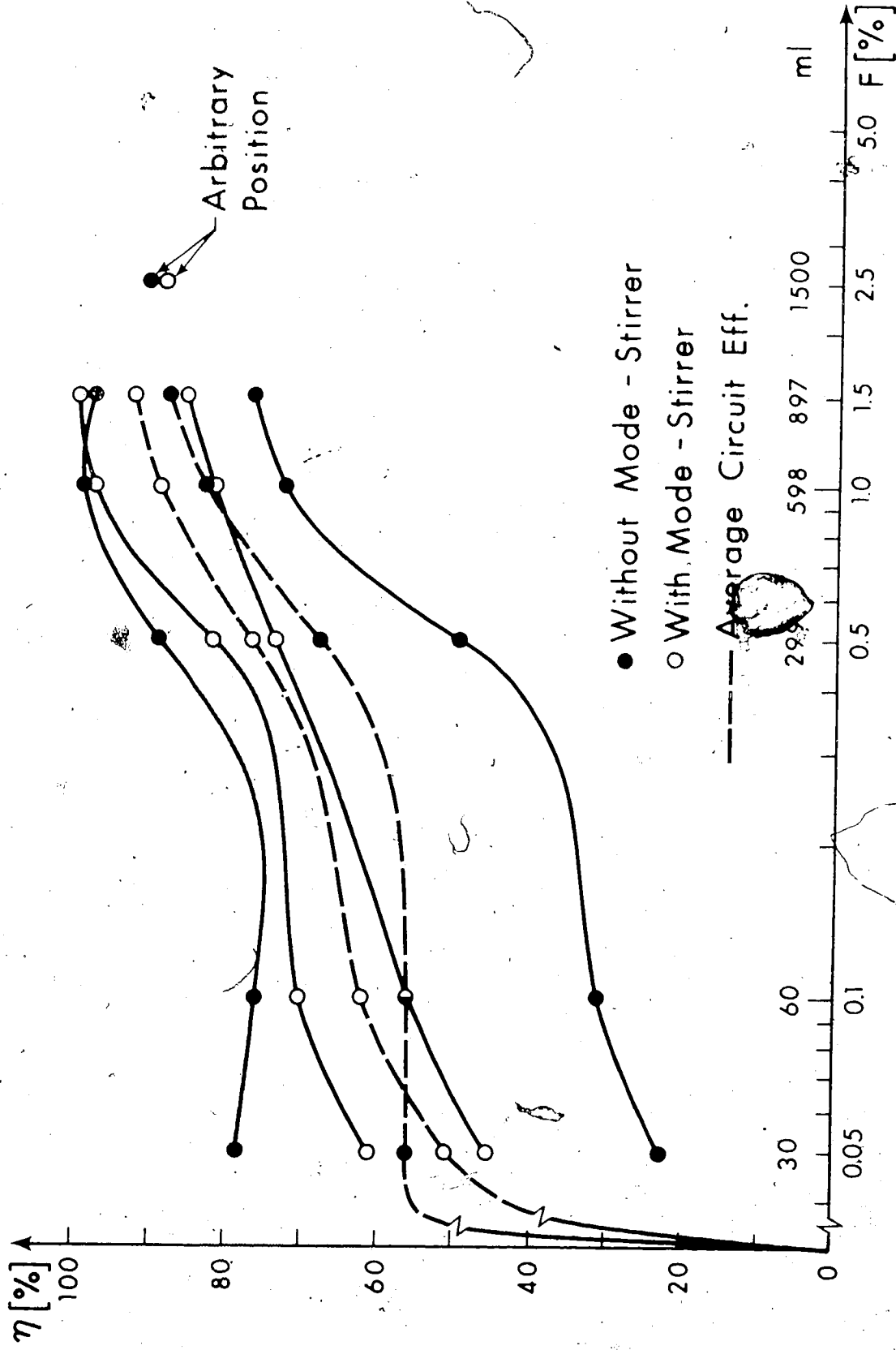

FIGURE 4.7 Relative circuit efficiencies for experimental cav and conventional magnetron, with isolator.

relevance in view of long lasting decisions on frequency allocations which are to be made in the near future (30). Proposals are already being made in which, at the ISM band of 2,450 MHz for instance, the 100 MHz bandwidth now available should be maintained (54). However, more data to add substance to these proposals are considered necessary.

Apart from bandwidth requirements due to tolerances on the center frequency of the magnetrons, it is desirable to establish whether larger operating bandwidths are necessary or desirable to improve the performance of microwave ovens, as measured by parameters such as circuit efficiency, efficiency dispersion and heating uniformity.

In the 2,450 MHz ISM band, over a bandwidth of 100 MHz, for instance, a typical return loss response of a microwave oven shows a number of maxima and minima. The shape of this response changes quite dramatically with the size and position of the load. Therefore, it is evident that if the cavity is excited by a narrowband (< 5 MHz) microwave generator, the return loss and hence the circuit efficiency can vary over a wide range and there is no way of controlling it. This is particularly true for small loads, due to the higher Q of the cavity. (see chapter 2, section 2.1).

4.3.1 Circuit Efficiency as a Function of Bandwidth Swept by the Source

The experiment reported in this section was aimed at determining the effect on circuit efficiency and efficiency dispersion, of frequency sweeping the source over different bandwidths, centered at 2,450 MHz, at constant input power. The filling factors, positions and containers for the water loads, were identical to all previous experiments with the experimental cavity. The coupling structure was the same waveguide (at 60) as used in the experiment discussed in 4.2.2. A low power (≈ 100 mW) sweep frequency oscillator was used, therefore, efficiencies were calculated from data on input and reflected power.

When sweeping over a bandwidth the circuit efficiency must be calculated as an average. If the input power is constant, at any frequency,

$$\eta(f) = 1 - \frac{P_r(f)}{P_i} \quad (4.1)$$

where, P_r = reflected power

P_i = input power

The average efficiency in a given bandwidth is given by:

$$\bar{\eta} = 1 - \frac{1}{(f_2 - f_1) P_i} \int_{f_1}^{f_2} P_r(f) df \quad (4.2)$$

Data on input and reflected power were obtained with a frequency domain reflectometer, and the integration in (4.2) was done electronically.

Results

Eleven source bandwidths were studied and the results are shown in Figure 4.8 where, for each filling factor, highest, lowest and average efficiencies are shown. As discussed earlier, for a lightly loaded multimode cavity, the return loss response, measured over a large bandwidth, exhibits sharp peaks and regions where little or no power is absorbed by the load. In these results it is seen that for 0.05% and 0.1% filling factors, the average efficiencies for the 5 MHz bandwidth are quite high. The graph merely indicates that at $2,450 \pm 2.5$ MHz there is a high return loss. At a different frequency the return loss could have been very low and, hence, a poor circuit efficiency would have resulted.

The main features of these results are: the negligible change in efficiency dispersion with increasing bandwidth for low filling factors (0.05 % and 0.1 %) and the considerable reduction in efficiency dispersions for medium

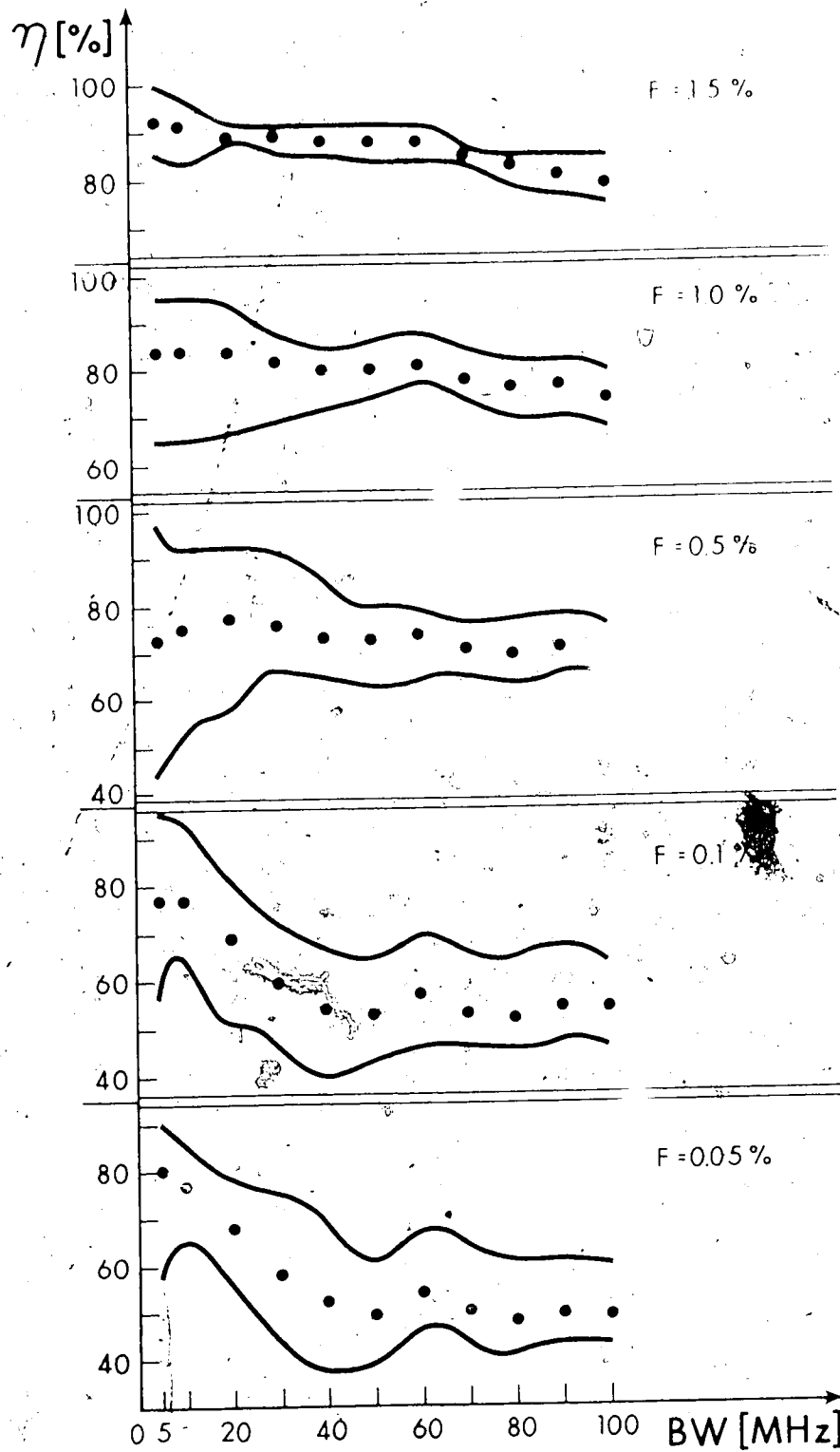

FIGURE 4.8 Relative circuit efficiencies for the experimental cavity, for different source bandwidths swept at constant input power.

to high filling factor loads for bandwidths of 40 MHz or more. Worth noting is the fact that the average efficiencies for low filling factors stabilize at a bandwidth of approximately 40 MHz.

It is reasonable to expect that this bandwidth is dependent on the number of modes that the cavity can sustain. In a 40 MHz bandwidth the cavity used in the experiments could sustain 8 modes. To achieve the same results in a smaller cavity, larger bandwidths would most probably be required. Further research on this point is considered necessary.

4.4 Conclusions

The following conclusions are derived from the results of the previous sections:

- 1.- A mode-stirrer significantly reduces the efficiency dispersion, i.e. it improves the ability of the system to cope with varying positions of a load. At least in systems which are not provided with an isolator, the price paid for this lower dispersion is a somewhat lower average efficiency due to increased reflections to the magnetron.
- 2.- The reduction in efficiency dispersion achieved

When a mode-stirrer is used, is mainly due to field perturbations, rather than to changes in the magnetron frequency due to pulling.

3.- In a system provided with a mode-stirrer, better results, i.e., smaller efficiency dispersions and higher average efficiencies are achieved with an isolator than without it.

4.- The presence of a base load reduces the efficiency quite rapidly for decreasing loads.

5.- A constant power microwave generator swept over bandwidths of 40 MHz or more, is effective in reducing the efficiency dispersion for medium to large loads, without significantly affecting the average efficiency.

Conclusion 4 is not only intuitively logical, but it is derived from a comparison of the slope of the average efficiency for the domestic oven, which included a base load, and the slope of the average efficiency of all the other experiments which were performed in the laboratory cavity, without a base load.

Conclusions 2 and 5 may appear to be somewhat contradictory, however, it must be recalled that, as shown in Figure 4.5b, frequency pulling of the magnetron in the experiment described in section 4.2.4 Case 1, was achieved over a bandwidth of 10 MHz only.

CHAPTER 5

CAVITY EXCITATION WITH A FREQUENCY AGILE SOURCE

Frequency is the most important parameter in controlling the performance of resonant microwave heating systems. In chapter 3 it was shown that different temperature patterns can be obtained by exciting the cavity in different modes and, in chapter 4, that efficiency dispersion is effectively reduced when the cavity is excited with constant power and the frequency is swept over a bandwidth of 40 MHz or more. These findings suggest a study on the potential of exciting a cavity with a frequency agile source. The use of such a source is investigated in this chapter.

A voltage tunable magnetron was used as the microwave source in the experiments performed but, as will be seen, the conclusions obtained are not restricted to the use of this particular tube. It will be shown that this approach leads to a great improvement in circuit efficiencies and to the possibility of tailoring temperature patterns.

5.1 The Voltage Tunable Magnetron (VTM)

The voltage tunable magnetron is one of the family of crossed-field microwave tubes. Frequency is made proportional to the anode voltage by heavily loading the resonant circuit with the output coupling (typical Q values are of the order of 10) and by controlling the injection of electrons so that the space charge is limited at some level below that which would be provided by a thermionic cathode.

The VTM makes use of a reentrant RF structure and the electron injection system is made up of a cold cathode, an emitter and a control electrode, as shown in Figure 5.1.

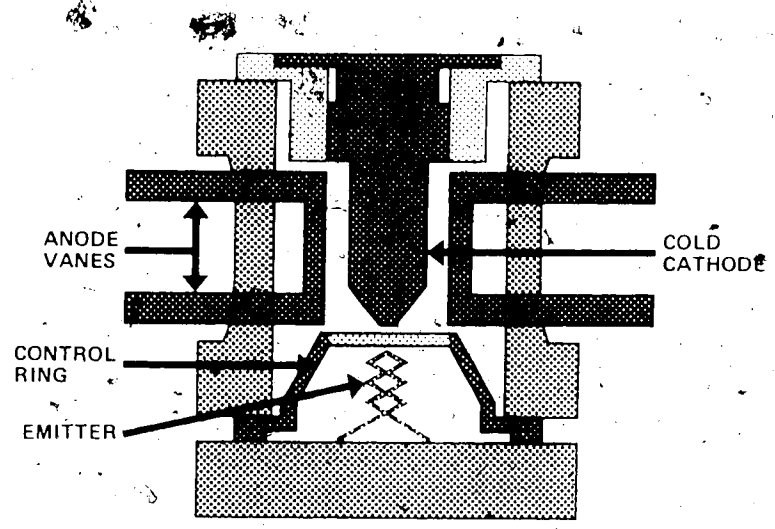

FIGURE 5.1 Cross section of a voltage tunable magnetron.

With the emitter located away from the interaction area, back-bombardment is essentially eliminated and the influence

of the anode voltage on the emitter is minimized. Usually, the control electrode voltage is a fixed fraction of the anode voltage, typically 30%, and is derived from the anode voltage through a resistive voltage divider. VTM's can also be designed to be amplitude modulated by varying the control electrode voltage. Because of the tight coupling required between the resonant circuit and the load, VTM's are normally supplied with an integral isolator. The isolator can work continuously with VSWR's of up to 2:1 and for 10 to 20 s with total reflection (a short or open circuit). Further information on the operation of VTM's can be found in the literature (55,56,57,58). The main characteristics of VTM's are:

- 1.- Near voltage-frequency relationship.
- 2.- Flat power-frequency response.
- 3.- Capability of high rates of modulation.
- 4.- High efficiency.
- 5.- Versatility.
- 6.- Small size, rugged structure and light weight.

For VTM's in the 0.25 W to 500 W power range, efficiencies vary between 50% and 70%, tuning ranges from 66% for the low power units to about 13% for a 500 W unit at 3 GHz and power variation, within the tuning range, is typically less than 1 dB. However, VTM's with higher output power and efficiency can be made at the expense of tuning range (58).

The following are the specifications of the VTM used in the experiments to be described:

Specifications of VTM Model: S2.25-265/150 MICTRON INC.

Output Power	150 watt
Efficiency	62%
Linear Sweep Range	2.25 - 2.65 GHz
Power Variation	±0.2 dB
Frequency Sensitivity	0.76 MHz/volt
Anode Voltage at Midband	3,825 Volts
Anode Current at Midband	0.063 Amps.
Control Electrode Voltage	1,200 Volts*
Control Electrode Current	0.001 Amps.
Filament Voltage	3 Volts
Filament Current	5 Amps.
Max. Sweeping Rate	50 MHz

*Obtained From Anode Voltage With A Resistive Voltage Divider.

The power supply used with this VTM is a commercial unit¹ that features independent adjustment of filament, anode and control electrode voltages, as well as a modulation input with variable gain. The full 400 MHz tuning range can be covered with a 10 V change in the modulation voltage. The VTM was supplied with an integral isolator.

Presently, VTM's are expensive and life expectancy is of the order of 500 h (56). Also, ripple in the anode

¹MICTRON INC., Model No. 100B4200.

voltage must be kept to a minimum if frequency modulation is to be avoided, and this puts stringent requirements on the power supply. However, a larger market for these tubes, which up to now have been mainly used in electronic countermeasures, would certainly stimulate further research to, lower costs, lengthen tube life and simplify power supply designs, as has already occurred with conventional magnetrons.

5.2 Maximization of Circuit Efficiency

The rather large variation in circuit efficiency for different loads in microwave ovens is due to the lack of control over the circuit and microwave source parameters. Thus, a compromise is made and today's microwave ovens are optimized for operation with a "typical" load.

5.2.1 Conventional Automatic Tuning Systems

One way of maximizing the circuit efficiency for any load is to provide the system with a conventional automatic tuning device. By this it is understood any scheme in which the load is matched to the source. The philosophy behind this approach is to adjust the circuit parameters so that

minimum reflected power is achieved at the operating frequency of the microwave source. Such an approach works well in principle and in practice (59,60), and it may well be justified in high power (>10 kW) industrial systems. For domestic microwave ovens or other small systems with similar characteristics, however, it has several disadvantages.

First, conventional automatic tuning devices operate satisfactorily only within narrow frequency bandwidths ($<2\%$). This precludes the possibility of exciting a wide variety of modes to improve heating uniformity. According to present technology a mode-stirrer would be required to achieve acceptable heating uniformity, but the rapid changes in the magnitude and phase of the reflection coefficient introduced by this device, would defeat the purpose of the automatic tuning control. Secondly, this type of tuning system requires fairly complicated electromechanical hardware. Best results are obtained with a triple stub tuner (60), which requires 6 detector diodes, 3 movable stubs with the corresponding electric motors and feedback devices and, a not too complicated electronic circuit. The minimum distance between the microwave generator and the cavity is $20/8\lambda_g$. At 2,450 MHz and in S band (WR284) waveguide, this means 60.4 cm.

It is clear that this type of automatic tuning system is not sufficiently flexible to improve the circuit efficiency of microwave ovens, and that the physical implementation of such a system requires a large amount of space and several mechanical and electromechanical parts. These would require frequent maintenance and would undoubtedly be the source of many problems.

5.2.2 Frequency Agile Source and Electronic Tuner

When the microwave source with which a cavity is excited has a resistive output impedance, two conditions (see Chapter 2) must be met in order to obtain maximum power transfer, the generator frequency must be equal to that of a cavity resonance and the equivalent cavity input resistance must be equal to the driving impedance. In a multimode cavity and within a given bandwidth, the above conditions are usually met, or at least approached, at several frequencies and their number is larger, the larger the bandwidth and the larger the number of modes that the cavity can sustain in that bandwidth.

From the above it follows, that, without changing circuit parameters by electromechanical tuning or by other means, maximum power transfer and, therefore, highest efficiency can be achieved by setting the source to a

frequency which yields minimum reflected power. This approach has been investigated using the system shown schematically in Figure 5.2. A detailed description of the design and circuitry used to implement the electronic tuner is given in appendix II.

Referring to Figure 5.2, a directional coupler samples the reflected power and a crystal diode generates a DC voltage proportional to that power. A directional coupler with a low coupling coefficient is required to ensure operation of the diode in its square law region. In operation, the clock starts the sweeping cycle in which the frequency of the VTM is continuously varied through the operating bandwidth. Everytime the reflected power goes through a minimum which is smaller than any previous one, the corresponding state of the ramp is stored in the memory, erasing what was previously stored. In this way, at the end of the sweeping cycle the memory contains the information necessary to set the voltage ramp and, hence, the frequency of the VTM, to give minimum reflected power. When due to changing properties of the load during the heating process, minimum reflected power is achieved at a different frequency, the VTM is locked to the new frequency in the next sweeping cycle. This frequency is maintained during the hold cycle and then the process is repeated.

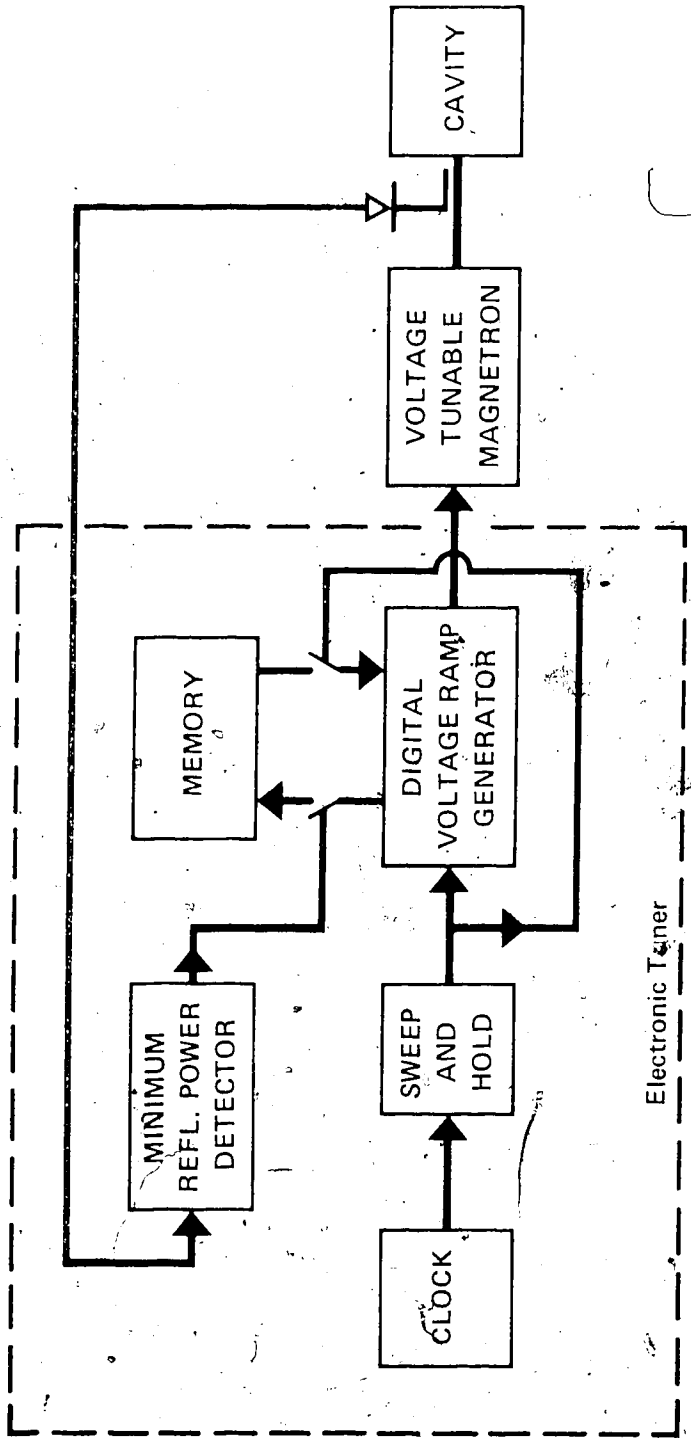

RESONANT SYSTEM WITH VTM AND ELECTRONIC TUNER

FIGURE 5.2 Simplified schematic diagram of the VTM-electronic tuner system.

5.2.3 Circuit Efficiency of Experimental Cavity Using the VTM and Electronic Tuner

Using the system just described and the same experimental cavity used throughout this thesis, two sets of experiments were performed to determine circuit efficiencies. The only difference between the two experiments was the use of different coupling structures. In the first, a probe coupler was used and in the second, a waveguide at an angle of 60° between the broad side and the horizontal. The type of loads, filling factors, positions in the cavity and procedure to calculate efficiencies, were all identical to those used in the experiments involving the experimental cavity reported in chapter 4. The electronic tuner was adjusted for sweeping and hold cycles of 100 ms and 5 s respectively, and the VTM was swept from 2,400 MHz to 2,500 MHz.

Results

Figure 5.3 shows highest, lowest and average values of circuit efficiencies for the coupling structures used. It is seen that, on the whole, efficiency dispersions are similar for both couplers, though smaller for large filling factors when the probe coupler is used. For small filling factors the average efficiencies are higher when the waveguide coupler is used and, in general, the rate of decline of the

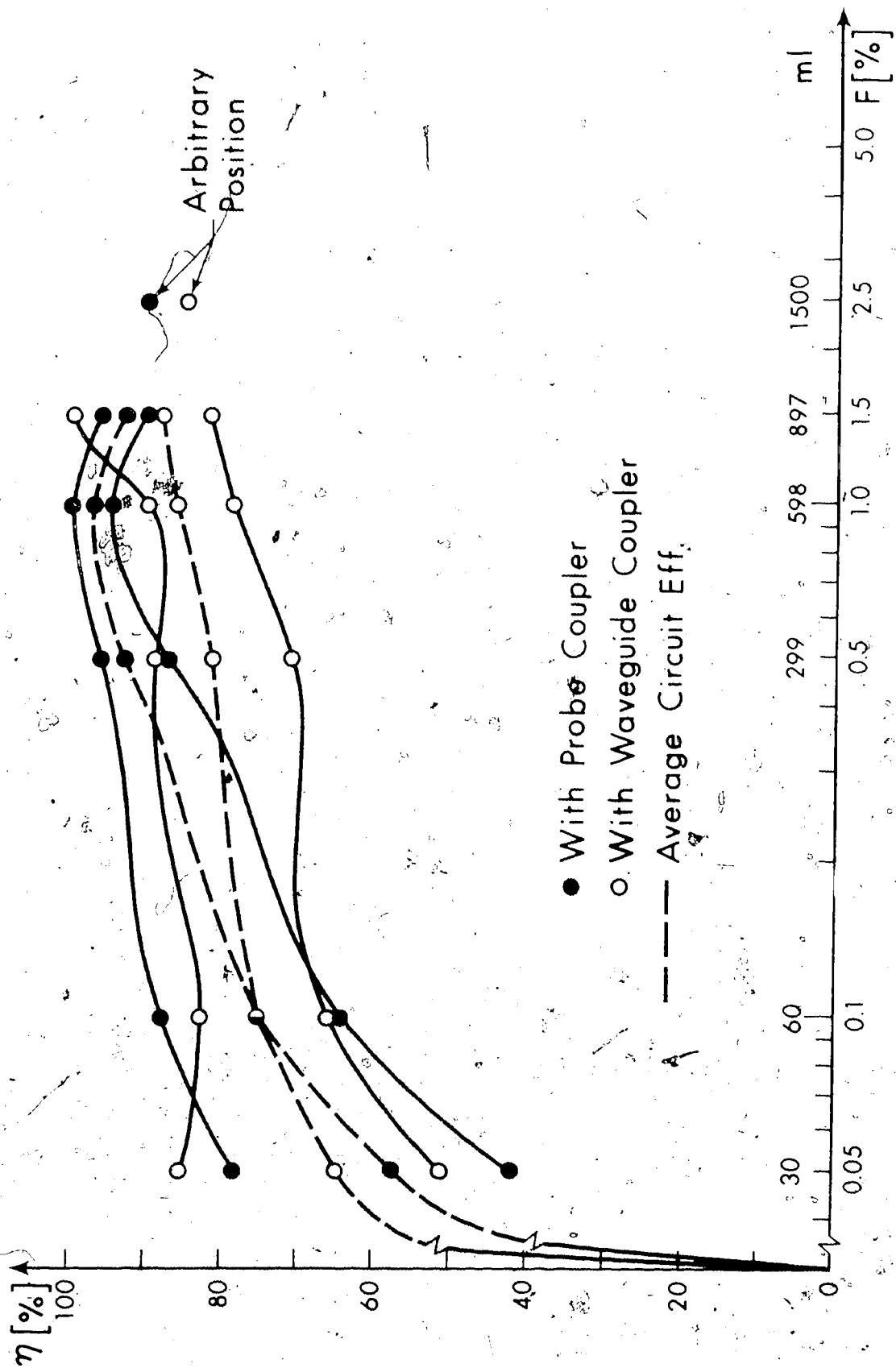

FIGURE 5.3 Relative circuit efficiencies for experimental cavity using the VTM and electronic tuner as source.

average efficiencies for decreasing filling factor loads are lower when the waveguide coupler is used.

These results can be better understood when the following is considered: a) because of circuit delay, the electronic tuner was unable to set the frequency of the VTM exactly, when the peaks of minimum reflected power were very sharp, b) these peaks were indeed very sharp for low filling factor loads and, c) the peaks of minimum reflected power were less sharp when the waveguide coupler was used, due to the stronger coupling (lower Q) provided by this coupler. For this same reason the magnitude of the peaks were somewhat lower for the waveguide coupler and, hence, the lower average efficiencies in most of the range of filling factors considered. Further research is required to find a coupling structure which gives optimum results when used with a frequency agile source and electronic tuner system. Certainly, one requirement is that it should be able to provide good coupling to as many modes as possible.

The results show that with an improved electronic tuner capable of setting the VTM frequency exactly and an optimized coupling structure, it is possible to obtain small efficiency dispersions and circuit efficiencies of the order of 90% and which remains nearly constant throughout the useful range of l/λ sizes.

Comparing these results and those obtained with a conventional magnetron in the same cavity (see Figure 4.2), it is seen that higher average efficiencies and much smaller efficiency dispersions are achieved with the VTM and electronic tuner system.

Efficiency dispersions obtained with the VTM, electronic tuner and probe coupler system are comparable to those obtained with the domestic oven. Efficiencies obtained with both systems are shown in Figure 5.4 and it is seen that the VTM system exhibits much higher efficiencies, especially towards the low filling factor end. Figure 5.5 shows the improvement in average efficiencies in percent. A minimum improvement of 20% is achieved for large filling factor loads and a maximum of 150% for small filling factor loads. This significant improvement in efficiency by use of the VTM certainly warrants the serious consideration of microwave oven manufacturers in setting future design trends for microwave ovens.

5.3 Heating Uniformity Test

The GSW Research Centre has developed a "Microwave Oven Heating Uniformity Test" (45), in which a statistical

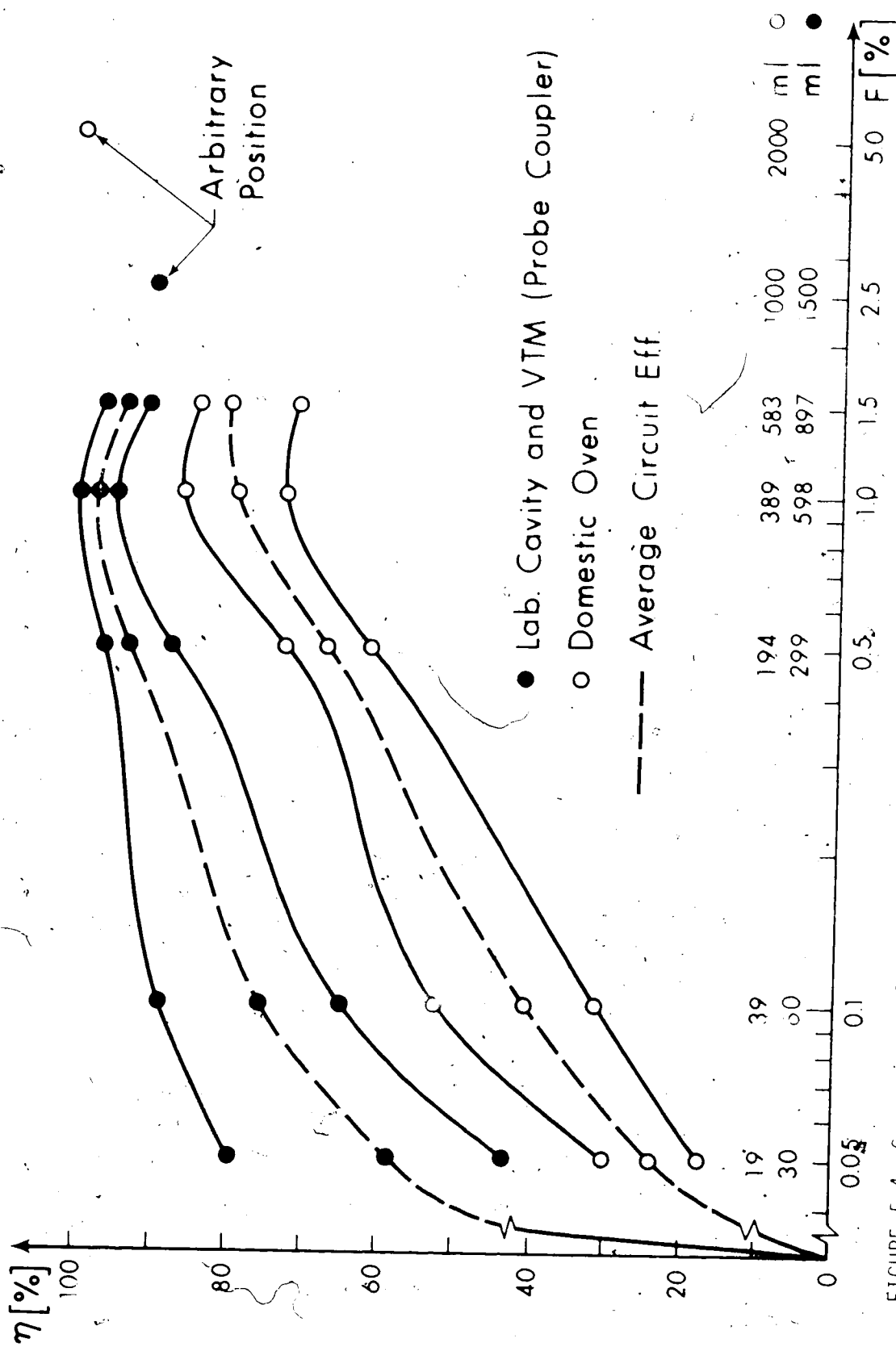

FIGURE 5.4 Comparison of circuit efficiency is obtained in the experimental cavity with the VTM electronic tuner system and in the domestic oven.

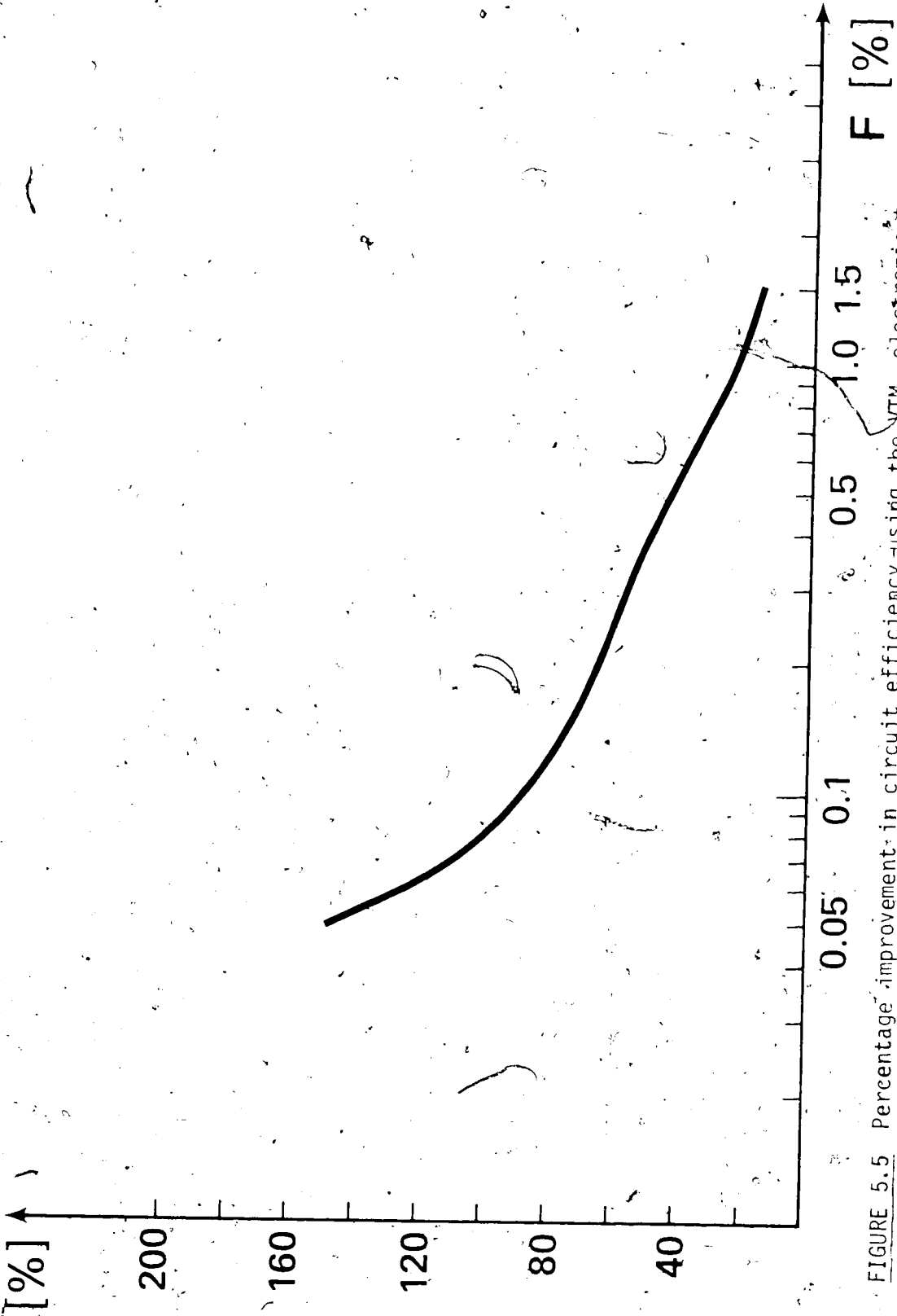

FIGURE 5.5 Percentage improvement in circuit efficiency using the VTM, electronic tuner and probe coupler, with respect to the domestic oven.

analysis is made of the temperature rise of a number of small water samples randomly placed in the oven being tested. The result of the test is a Distribution Ratio (D.R.) figure which has an optimum value of 1 if the temperature rise in all the samples is the same. The test was applied by the GSW Research Centre to 10 different domestic ovens. Three were selected and each was given to the same housewife to be used for one month. At the end of the three months she was asked to grade the ovens in order of cooking uniformity. Her judgement was in agreement with the results of the GSW test for the three ovens.

The GSW test was applied to the laboratory cavity with the VTM as the source. The VTM was continuously swept at constant power from 2,400 MHz to 2,500 MHz. The test was also applied to two domestic microwave ovens.

Results

The results are the following:

Laboratory Cavity and VTM	D.R. = 2.41
Domestic Oven #1	D.R. = 9.55
Domestic Oven #2	D.R. = 4.66

These results show a distinct improvement in heating uniformity when frequency sweeping the source.

5.4 Temperature Pattern Tailoring

Superposition of temperature patterns by exciting a cavity with separate microwave sources has been demonstrated experimentally (see chapter 3). However, the same effect can be achieved with a single microwave source whose frequency is sequentially changed to those values which generate the patterns that are to be superimposed.

An experiment aimed at demonstrating this principle was performed. The frequency of the VTM was sequentially changed to three different values by means of a modulator which is described in appendix III. In essence, this modulator is a circuit which sequentially generates a voltage with three independently adjustable levels. The duration of each voltage level is the same, i.e., one third of the sequence time.

For the purpose of showing the operation of such a system, three frequencies were found which yielded temperature patterns whose hot spots did not, in general, coincide. The load was the same 30 cm square lossy sheet covered with liquid crystals used in chapter 3.

Results

Figure 5.6 shows the temperature patterns obtained in this case, at 2,410 MHz, 2,480 MHz and 2,490 MHz, and the pattern corresponding to their superposition. The result, as can be seen, is an almost perfect superposition of the three patterns. This technique allows, if necessary, for giving different weighting factors to the patterns that are to be superimposed. This does not require changing power levels, but merely the duration of the different voltage levels of the modulator. Extension of the modulator circuitry to generate any number of voltage levels is straightforward.

5.5 Discussion

Three ways of using a frequency agile source have been investigated in this chapter, and have been shown to be powerful techniques for; obtaining high circuit efficiency, with small efficiency dispersions, improving heating uniformity and tailoring temperature patterns.

Maximizing efficiency does not guarantee good heating uniformity and, conversely, a technique that allows control of temperature patterns does not guarantee high efficiency. In resonant microwave heating systems, highest possible efficiency and highly uniform temperature patterns are goals

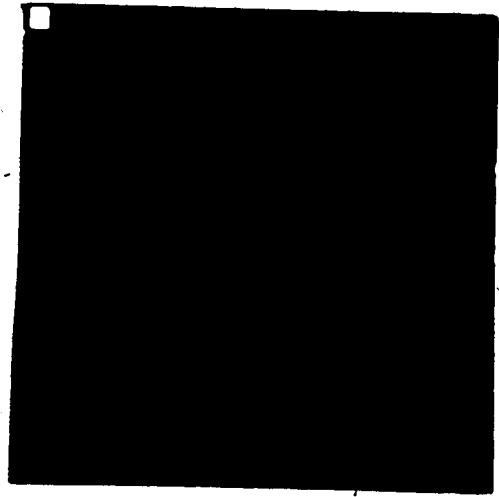

2,410 MHz

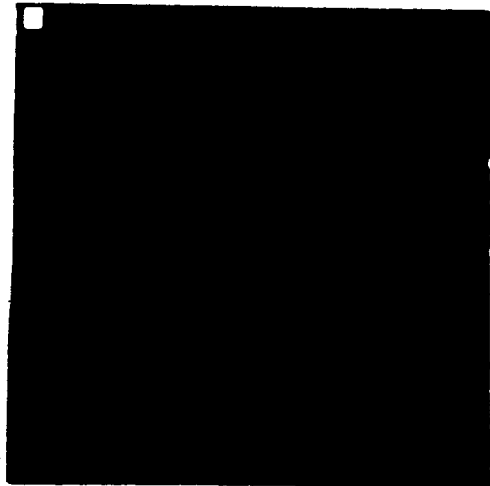

2,480 MHz

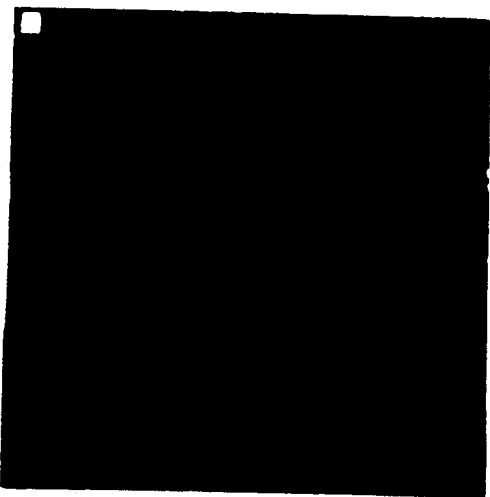

2,490 MHz

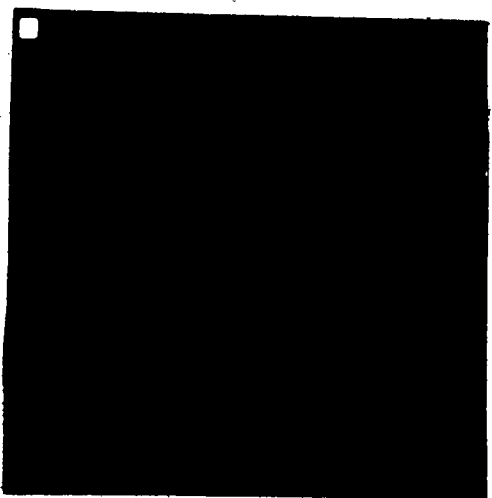

Superposition

FIGURE 5.6 Superposition of three temperature patterns using the VTM and the discrete frequency modulator.

that are difficult to achieve simultaneously (61). A compromise is possible, however, by operating a frequency agile source in a fourth way. During the sweeping cycle of the electronic tuner, all the frequencies for which the reflected power is below a prescribed value would be stored. In the "hold" cycle, the frequency of the source would be sequentially set to those values for a period of time. The different temperature patterns would improve heating uniformity with a guaranteed minimum efficiency.

Operating a frequency agile source in any of the four ways discussed and, perhaps, in more sophisticated ways, can easily be accomplished using today's microprocessor technology. In any case, the success of any of the techniques described requires:

a.- As large an operating bandwidth as possible. At 2,450 MHz no less than 80 MHz to 100 MHz should be available.

b.- A cavity that can sustain a large number of modes in the operating bandwidth. A computer program to optimize the dimensions of a cavity, in this respect, was written and is given in appendix IV.

c.- A coupling structure capable of exciting as many modes as possible. A slow wave coupler may be the most adequate (39).

Base loads, which are often used in microwave ovens to protect the magnetron, are not necessary with a frequency agile source and electronic tuner system. This is one reason why higher efficiencies are possible with such a system, especially for low filling factor loads. If desired, however, it is easy to shut-off the source if the reflected power to the tube is too high.

Other frequency agile sources which could be used in microwave heating are: modified conventional magnetrons (62) and solid-state microwave generators. In appendix I multiple solid-state sources and a single solid-state source, using power dividing-combining techniques, are discussed as alternative approaches for the excitation of a cavity with a frequency-agile source.

CHAPTER 6

CONCLUSIONS

Reduction of efficiency sensitivity to loading conditions and improvement of heating uniformity in microwave ovens, are presently achieved using a mode-stirrer. It has been shown in this work that these effects are due to perturbations of the fields in the cavity, rather than to frequency variations of the magnetron due to pulling. In systems not provided with an isolator, however, a reduction in efficiency results from the reflections introduced by the mode-stirrer.

Frequency has been found to be the most important parameter in controlling the performance of resonant microwave heating systems. A new technique which makes use of a frequency agile microwave source has been developed, together with an electronic circuit which allows operation of a resonant microwave heating system at the maximum possible efficiency under given loading conditions. With this technique a large improvement in circuit efficiency over a domestic microwave oven using conventional techniques has been demonstrated, especially for low filling factor loads. Frequency sweeping of the source over ranges of the order of 40 MHz, in the 2,450 MHz ISM band, is another

effective way of reducing efficiency sensitivity to load positioning. However, bandwidths of the order of 80 MHz to 100 MHz are likely to be required in cavities of smaller size than the one tested. Frequency sweeping of the source has also been shown to be effective in improving pattern uniformity.

A new technique has been developed whereby the temperature pattern in a load can be tailored to a considerable degree. The technique makes use of a frequency agile source and suitable frequency modulating circuitry. The successful operation of the techniques involving a frequency agile source, requires as large a source bandwidth as possible and the excitation of as large a number of modes in that bandwidth as possible.

The theoretical prediction of temperature patterns in low profile loads exposed to electromagnetic energy in a resonant cavity has been demonstrated. Correlation between theoretical and experimental patterns is very good, considering the simplicity of the mathematical model used.

A single transistorized microwave generator, using power dividing-combining techniques, has been shown to be the most suitable approach for the design of an all solid-state frequency agile source.

For microwave heating applications, requirements for a 100 W source of power, compact size, and low voltage are sought in an attractive solution due to their low operating voltage and small size. A 100 W source at 10 GHz consisting of a transistor and a ~~stripline~~ ^{coaxial} applicator have been designed. Using this combination, a 25 mm in diameter and 3 mm in depth patch of industrial grade epoxy glue was cured in 45 s. Room temperature curing time for this epoxy is 2 to 3 h.

LIST OF REFERENCES

- (1) Puschner, H., Heating With Microwaves, Philips Technical Library, Eindhoven, 1966, p. 1.
- (2) Anon., "Radarange for Cooking", Electronics, vol. 19, p. 178, November 1946.
- (3) Anon., "Electronic Cooking Goes Commercial", Electronics, vol. 20, p. 140, June 1947.
- (4) Anon., "Microwave Cooking Warms Up", Electronics, vol. 30, p. 1, September 1957.
- (5) Koop, J.A., "Changing Perceptions of Food in Modern Life", Trans. of the International Microwave Power Institute, vol. 5, pp. 5-19, Edmonton, Canada, 1975.
- (6) Mennie, D., "Microwave Ovens: What's cooking?", IEEE Spectrum, March 1975, pp. 34-39.
- (7) McConnell, D.R., "Introduction and Forecast of Future Growth", Trans. of the International Microwave Power Institute, vol. 4, pp. 3-4, Edmonton, Canada, 1975.
- (8) Anon., "News Items of Interest", Microwave Energy Applications Newsletter, vol. IX, pp. 11-16, Sept.-Oct. 1976.
- (9) "Microwaves: An Industry with Interesting Potential", International Microwave Power Institute Newsletter, vol. 2, no. 4, pp. 15-16, November 1974.
- (10) Giles, P.G., "Microwave Food Applications in the United

- Kingdom: Domestic and Commercial Microwave Ovens", J. Microwave Power, vol. 8, pp. 129-132, 1973.
- (11) Kase, Y., "Microwave Ovens in Japan", International Microwave Power Institute Newsletter, vol. 3, pp. 2-4, June 1975.
- (12) Marcus, J. and Kinn, T.P., "Heating With Microwaves", Electronics, vol. 20, pp. 82-85, March 1947.
- (13) Morse, P.W. and Revercomb, H.E., "UHF Heating of Frozen Foods", Electronics, vol. 20, pp. 85-89, October 1947.
- (14) Nelson, F.B., "Industrial Magnetrons for Dielectric Heating", Electronics, vol. 25, pp. 104-109, August 1952.
- (15) Crapuchettes, P.W., "Microwaves on the Production Line", Electronics, vol. 39, pp. 123-130, March 1966.
- (16) Gerling, J.E., "Microwave Heating Patents", Trans. of the International Microwave Power Institute, vol. 1, pp. 159-170, Edmonton, Canada, 1973.
- (17) Goldblith, S.A. and Decareau, P.V., An Annotated Bibliography on Microwaves, The MIT Press, Cambridge, Mass., 1973.
- (18) Osepchuk, J.M., "Microwave Engineering Problems in the Microwave Oven", Digest of the 1976 IEEE MTT-S International Microwave Symposium, pp. 334-335.
- (19) Consumers' Research Magazine, "Microwave Ovens", November 1976, pp. 7-13.
- (20) Ohlsson, T. and Bengtsson, N., "Microwave Heating

- Profiles in Foods", Microwave Energy Applications Newsletter, vol. IV, Nov.-Dec. 1971, pp. 3-8.
- (21) Takeda, S., Hashimura, T. and Asanuma, K., "Toshiba Electronic Ovens and Their Safety", Toshiba Review, No. 80, April 1973.
- (22) Ohlsson, T., "Temperature Distribution in Microwave Oven Heating: Experiments and Computer Simulations", Symposium Paper Summary, J. Microwave Power, vol. 11, pp. 178-179, 1976.
- (23) Decareau, R.V., "Commercial Microwave Food Service Applications", Trans. of the International Microwave Power Institute, vol. 5, pp. 78-88, Edmonton, Canada, 1975.
- (24) Levinson, M.L., "Methods of Microwave Heating in Metal Containers", U.S. Patent 3,985,991, 1976.
- (25) McConnell, D.R., "Energy Consumption: A Comparison Between the Microwave Oven and the Conventional Electric Range", J. Microwave Power, vol. 9, pp. 341-347, 1974.
- (26) Oserchuk, J.M., "Basic Principles of Microwave Ovens", Trans. of the International Microwave Power Institute, vol. 4, pp. 5-54, Edmonton, Canada, 1975.
- (27) Kumpfer, B.D., "Microwave Power Generation", Trans. of the International Microwave Power Institute, vol. 1, pp. 65-73, Edmonton, Canada, 1973.
- (28) Suzuki, T., Iwasaki, K., Goto, T. and Koinuma, T.,

- "Magnetrons for Microwave Heating", Toshiba Review, No. 23, pp. 22-28, 1965.
- (29) Fukatsu, A., Takahashi, H., Kato, M. and Koinuma, T., "Advanced Magnetrons for Electronic Ovens", Toshiba Review, No.66, pp. 26-33, 1972.
- (30) Osepchuk, J.M., "A Call to Action on Frequency Allocation Matters", Microwave Energy Applications Newsletter, vol. IX, Nov.-Dec. 1976, p. 14.
- (31) Watanabe, M., Suzuki, M. and Sugimoto, K., "Theoretical and Experimental Study on Uneven Heating in Microwave Ovens", Presented at the International Microwave Power Institute Symposium, Monterey, 1971.
- (32) Ramo, S., Whinnery, J.R. and Van Duzer, T., Fields and Waves in Communications Electronics. New York: Wiley, 1965, p. 546-547.
- (33) James, C.R., Voss, W.A.G. and Tinga, W.R., "Some Factors Affecting Energy Conversion in Multimode Cavities", J. Microwave Power, vol. 1, pp. 97-107, 1966.
- (34) Copson, D.A. and Decareau, R.V., "Ovens", in Microwave Power Engineering, (ed. Okress, E.C.) vol. II, pp. 10-11, Academic Press, New York, 1968.
- (35) Hitachi Co., Chicago, Data Sheets on Magnetrons: Models 2M170 and 2M121, 1976.
- (36) Kadono, K., "An Advanced Magnetron For Consumer Microwave Ovens", Proceedings of the 1973 Microwave

- Power Symposium, Loughborough, Session 5B1, IMPI, Edmonton, Canada.
- (37) In reference (1), p.41.
- (38) Hull, M.D. and Thompson, L.J., Designing Microwave Catering Equipment, Philips Application Book, Eindhoven, 1971, pp.38-39.
- (39) Johnston, D.A., "Travelling Wave and Resonant Microwave Heating Applicator Design", Ph.D. Thesis, University of Alberta, August 1972.
- (40) Hauck, H.S., "Design Considerations for Microwave Oven Cavities", IEEE Trans. on Industry and General Applications, vol. IGA-6, pp. 74-80, Jan./Feb. 1970.
- (41) Schmidt, W., "Microwave Generators Coupled to a Loaded Cavity", Electronic Applications, vol. 19, pp. 147-164, 1958-1959.
- (42) Berntsen, W.T. and David, B.D., "Determining the Electric Field Distribution in a 1250 Watt Microwave Oven and its Effect on Portioned Food During Heating", Microwave Energy Applications Newsletter, vol. 8, July-August 1975, pp. 3-10.
- (43) Wilhelm, M.S. and Satterlee, L.D., "A 3-Dimensional Method for Mapping Microwave Ovens", Microwave Energy Applications Newsletter, vol.4, September-October 1971.
- (44) Van Zante, H.J., The Microwave Oven, Houghton Mifflin Co., Boston, 1973, pp. 55-57.
- (45) GSW Research Centre, Toronto, "Microwave Oven Heating

- Uniformity Test", Private Communication to Dr. W.R. Tinga, 1976.
- (46) Fanslow, G.E., "Field Patterns in Slotted Waveguides", Proceedings of the 1974 Microwave Power Symposium, Milwaukee, Wis.
- (47) Pritchard, W.L., "Microwave Ovens", U.S. Patent 2,763,757 1956.
- (48) Staats, J.E. and Fitzmayer, L.H., "Microwave Oven Having TM and TE Modes", U.S. Patent 3,843,862 1974.
- (49) Saad, T.S., "Beam Stirrer", U.S. Patent 3,939,320 1976.
- (50) Mackay, A., "On the Fourier Addition of Modes", J. Microwave Power, vol.10, pp. 209-210, July 1975.
- (51) In reference (32), pp. 400-410.
- (52) Puschner, H., "Microwave Heating Technique in Europe", J. of Microwave Power, vol.2, pp. 31-44, 1967.
- (53) Ogura, K., Takahashi, H. and Tashiro, N., "A New Approach for a Magnetron for Household Microwave Ovens", Presented at the International Microwave Power Institute Symposium, Leuven, 1976.
- (54) "Proposed IMPI Position Paper on Frequency Allocation Matter", Microwave Energy Applications Newsletter, vol. IX, November-December 1976, p.15.
- (55) Weinstein, M., "Voltage-Tunable Magnetron State of the Art", Microwave Journal, vol. 5, pp. 162-166, October 1962.
- (56) Curtis, T.P. and Vaughan, J.R.M., "The High Power

- Voltage-Tunable Magnetron (VTM)", Microwave Journal, vol. 12, pp. 61-64, April 1969.
- (57) VTM Microwaves Inc., Boulder, Colorado, Voltage Tunable Magnetron Handbook, 1976.
- (58) Wilbur, D.A. and Peters, P.H., "The Voltage Tunable Magnetron", in Crossed-Field Microwave Devices, (ed. Okress, E.C.), vol. II, pp. 35-81, Academic Press, New York, N.Y., 1961.
- (59) VanKoughnett, A.L. and Wyslouzil, W., "An Automatic Tuner for Resonant Microwave Heating Systems", J. Microwave Power, vol. 6, pp. 25-30, April 1971.
- (60) Wyslouzil, W. and VanKoughnett, A.L., "Automated Matching of Resonant Microwave Heating Systems", J. Microwave Power, vol. 8, pp. 89-100, March 1973.
- (61) Valles, B., "A 2,450 MHz Low Cost Magnetron for Consumer Use", J. Microwave Power, vol. 6, pp. 313-320, 1971.
- (62) International Newsletter, in Electronics, vol. 49, p. 56, April 1976.
- (63) Casterline, E.T. and Benjamin, J.A., "Trends in Microwave Power Transistors", Solid State Technology, vol. 18, pp. 51-56, April 1975.
- (64) A.W., "Opening Up the Commercial Market", Microwave Journal, vol. 15, p. 49, June 1972.
- (65) B., "Semiconductors Prove Fruitful for Microwave Power Devices", Electronics, vol. 49, pp. 83-

90, February 1976.

- (66) Davis, R., "Microwave Power on the Rise", *Microwaves*, vol.13, p.9, April 1974.
- (67) Copson, D., *Microwave Heating and Freeze Drying*, AVI Publishing Co., Westport Ct., 1962.
- (68) Gerling, J.E., "Microwave Processing Equipment-A Modular Approach", *Food Technology*, vol.22, pp. 106-109, January 1968.
- (69) In reference (1), pp. 185-187.
- (70) Kamide, H.P., "Electronic Heating Methods and Apparatus", U.S. Patent 2,895,828 July 1959.
- (71) Kegereis, J.E., Perry, J.T. and Fenyon, F.M., "Apparatus and Method for Heating Simultaneously with Microwaves of Two Widely Different Frequencies" U.S. Patent 3,806,689 April 1974.
- (72) McAvoy, B.R., "Solid State Microwave Oven", U.S. Patent 3,557,333 January 1971.
- (73) Chang, K.K., "Solid State Microwave Heating Apparatus", U.S. Patent 3,691,338 September 1972.
- (74) Davis, R., "Hybrid Combined Transistor Amplifier Delivers 500 W CW", *Microwaves*, vol.13, p. 9, June 1974.
- (75) Ebersol, E.T., "L-Band Transistor Amplifier Dishes Out 1 KW", *Microwaves*, vol.11, p.9, December 1972.
- (76) Yee, H.Y., Chang, F. and Audeh, N.F., "N-Way TEM-Mode Broad-Band Power Dividers", *IEEE Trans. Microwave*

- Theory and Techniques, vol. MTT-18, pp. 682-688, October 1970.
- (77) Wilkinson, E.J., "An N-Way Hybrid Power Divider", IRE Trans. Microwave Theory and Techniques, vol. MTT-8, pp. 116-118, January 1960.
- (78) Guy, A.W., Lehmann, J.F. and Stonebridge, J.B., "Therapeutic Applications of Electromagnetic Power", Proc. IEEE, vol. 62, p. 55, January 1974.
- (79) Romero-Sierra, C., Halter, S., Tanner, J.A., Boomis, M.W. and Crabtree, D., "Electromagnetic Fields and Skin Wound Repair", J. Microwave Power, vol. 10, pp. 59-70, 1975.
- (80) Microwave Semiconductor Corp., Somerset, N.J., Data Sheets On 1 GHz Power Transistors.
- (81) Hodowanec, G., "High-Power Transistor Microwave Oscillators", RCA Application Note AN-6084.
- (82) Young, G., "Microstrip Design Techniques for UHF Amplifiers", Motorola Application Note AN-548.
- (83) Saad, T.S. (Ed.), Microwave Engineers Handbook, vol. 1, Artech House Inc., Dedham, Mass., 1973.
- (84) Kamnitsis, C., "Broadband Matching of UHF Micro-Strip Amplifiers", Microwaves, vol. 8, pp. 54-56, April 1969.
- (85) Johnson, J. and Moutoux, T., "For a Long-Life Power Transistor, Cool It", Microwaves, vol. 12, pp. 46-54, August 1973.

APPENDIX ISOLID STATE MICROWAVE POWER GENERATORS

Solid-state devices have many attractive features for microwave heating applications. They are small and rugged, have a long life span (MTBF of 100,000 h for some transistors) (63) and, except for Impatt diodes, operate with voltages below 50 V. Equipment using low voltage active devices to generate microwave power are less dangerous to service, require low voltage high current power supplies which are less costly than high voltage low current power supplies (64), and greatly simplify the design of mobile systems.

In this appendix the state-of-the-art of microwave power transistors is reviewed and two techniques for operating a microwave oven with transistorized sources are discussed. Also, a practical application of a 20 W transistorized source used with a fringing-field applicator is given.

1.- Transistorized Microwave Generators

CW power output capability and efficiency are the two most important parameters to be considered, when selecting

the most suitable semiconductor device for microwave heating applications. For frequencies below 5 GHz the bipolar transistor is by far the most powerful and efficient microwave semiconductor (65). From 1964 to 1974 a tenfold increase in transistor performance, in terms of frequency and output power, was achieved (63). The main goals in that period were to develop higher power and higher frequency transistors. From 1974 on, however, the goals have been to improve reliability, efficiency and bandwidth (66). Typical specifications for state-of-the-art transistors are:

	1 GHz	2 GHz
Power Output (W)	40	20
Efficiency (%)	55	45
Gain (dB)	8	7

Minimum bandwidths of 6% to 10%, 28 V collector voltage and MTBF of 10,000 to 100,000 h are typical.

The first microwave power transistors which appeared on the market had such low input and output impedances, that designing and actually making the external matching circuitry was very difficult. They were also very sensitive to a loading mismatch. Today, many transistors are offered with internal matching. This technique uses MOS chip capacitors and discrete bond wire lengths placed inside the

transistor package. In this way, efficiency was improved 5% to 10%, thus reducing junction temperature and improving reliability. Input and output impedances have also been increased, greatly simplifying the design of external matching circuits. Sensitivity to load mismatch has been drastically reduced, to the point that many transistors today are guaranteed to withstand an infinite VSWR for all phases at rated output power.

In spite of these advances, the output power from single transistors is far from that required in most microwave heating applications. Although the theoretical limitations on power output for a microwave transistor are, according to one author (63), approximately 800 W at 1 GHz and 400 W at 3 GHz, it is obvious that these values represent goals difficult to achieve. Taking state-of-the-art transistors or even assuming more realistic future values of 100 W at 1 GHz and 50 W at 3 GHz, it is unavoidable that some power combination techniques have to be used in order to reach the power levels required for microwave ovens. One of these techniques is discussed at length in the next section. In section 3 another technique is discussed, together with the description of a practical example of a low power (< 100 W) application where microwave transistors can find immediate use.

2.- Multiple Sources in Microwave Heating Systems

The idea of using multiple sources of microwave power in microwave heating systems is not new (15). Copson (67) reported their use in freeze drying systems, Gerling (68) reported their use in food processing equipment and Puschner (69) describes how a cavity can be excited with two sources. Kamide (70) and Kegereis et al. (71) were issued patents which describe the use of two sources operating at two widely different frequencies (915 MHz and 2,450 MHz).

The use of multiple sources has been proposed for several reasons: to increase the power level in the system, to improve heating uniformity, to increase operating reliability and, in the case of sources operating at widely different frequencies, to take advantage of the normally different penetration depths.

The main problem of using more than one source is the cross-coupling of energy between them. This problem is not too serious, however, in conveyORIZED systems in which the applicator is a series of cascaded cavities. In systems of this type the microwave power sources are usually mounted side by side above the conveyor belt. Each source can be tuned to couple optimally to the load passing below and to

minimize coupling to the neighboring sources. Since the load is constant, retuning is seldom required. Metal baffle plates are sometimes introduced between adjacent coupling structures, to reduce cross-coupling to acceptable levels.

In microwave ovens, in which the load can vary over a wide range, the cross-coupling problem is particularly serious. For a given loading condition, any one source can receive an appreciable amount of reflected power, in addition to power coupled from the other sources. Copron mentions the problem but doesn't go much further. For two sources, Buschner suggests the use of cross-polarized coupling structures mounted on one cavity wall. In multimode cavities, however, most modes have non-zero integers l , m and n and, therefore, TE and TM modes have two and three components of electric field respectively, which are at right angles to each other. The success of this technique seems doubtful, particularly for more than two sources.

Reducing cross-coupling becomes increasingly difficult as the number of sources is made larger. At the same time, the larger the number of sources the more necessary it is to achieve negligible cross-coupling, because of the increasing ratio of total power in the cavity to power handling capability of each source. Despite these difficulties, it is natural to think of multiple sources when investigating the

use of solid-state generators in microwave heating applications.

McAvoy (72) describes a microwave oven in which the microwave power is generated by a large number of diode (Gunn or avalanche type) oscillators, which are mounted on the walls inside the cavity. No mention is made of the cross-coupling phenomenon or how the diodes can withstand the electric field intensities corresponding to the total power in the cavity. Chang (73) describes a similar system but suggests the use of isolators to protect the oscillators. This is an expensive solution and can seriously reduce the circuit efficiency of the system.

Another way of using multiple solid-state sources is to operate them in a pulsed mode. Suitable circuitry would sequentially switch the sources so that only one would be on at any instant. This, however, is not a practical solution with state-of-the-art microwave power transistors because the ratio of pulsed to CW output power is of the order of 3 for 1% duty cycles.

In view of what has been discussed and the fact that with present solid-state technology, no less than 35 sources would be required for a 600 W microwave oven at 2,450 MHz, the use of multiple solid-state sources does not appear to

be feasible for now.

3.- Power Dividing-Combining Technique and Low Power Applications

3.1^a Power Dividing-Combining Technique

A technique to obtain high levels of microwave power which is proving very fruitful, makes use of power divider and power combiner networks. These networks are essentially the same. A typical configuration starts with an oscillator followed by a driver amplifier. Through a power dividing network, this amplifier drives as many other amplifiers as required (2, 4, 8, etc.), and the output powers of these amplifiers are finally combined in a single output.

Using a similar arrangement, a 500 W CW class C amplifier has been built (74). The amplifier operates in the 960 MHz to 1,212 MHz band, uses 22 transistors, exhibits a midband gain of 20 dB and an overall efficiency of 30%. A 1 kW L-Band pulse power amplifier with a center frequency of 1,250 MHz has also been built (75), with a gain of 7.2 dB and an efficiency of 35% at midband. The reduction in efficiency, from that for single transistors, is mainly due to the losses in the power divider and power combiner.

networks. Recognizing this fact, efforts are being made to develop less lossy and wider bandwidth power dividers (combiners) (76,66) to substitute for the classical Wilkinson (77) power divider used so far.

From a technical point of view this approach is the most feasible for the development of an all solid-state microwave oven. It also allows control of the output power and frequency, simply by controlling these parameters in the low power oscillator. Further control of the operating frequency can be obtained by a voltage controlled oscillator (VCO). Little information is found in the literature that allows an accurate estimate of the cost, for instance, of a 500 W unit. Judging by the cost of individual transistors, however, one can estimate a present cost of a few dollars per watt. From this point of view, it is not likely that solid-state power generators will be able to compete with conventional magnetrons for use in microwave ovens, at least for sometime.

3.2 Low Power Applications

The best known microwave power applications usually involve power levels above 400 W. There are, however, applications where power levels of less than 100 W are

required. These include diathermy (78), skin wound repair (79) and curing of adhesives. In applications such as these, transistorized microwave power generators offer very desirable features, in particular, low voltage operation and small size. Both characteristics make possible the design of handheld generators which are safe to operate.

For the purpose of evaluating the difficulties involved in the design of a small microwave generator, a 20 W unit operating at 915 MHz was built. Details of the design and construction are given in section 4. The design was very successful in that only two transistors were required; one operating as a power oscillator and the other as a class C power amplifier. The transistor used in the amplifier is rated at 20 W output power for a case temperature of 25 °C, therefore, the 18 W obtained are considered a good achievement.

A fringing field coaxial applicator was also designed and built, in order to investigate the use of the transistorized microwave power generator in curing epoxy adhesives. The applicator is, essentially, a coaxial line with a flared outer conductor. The diameter of the inner conductor increases towards the end of the applicator, to maintain a constant characteristic impedance. The shape of the end of the center conductor controls, to some extent,

the field pattern in the load.

Figure A1.1a shows a partial view of the applicator, and the temperature pattern in a thin liquid crystal load in a vertical plane. In b, the temperature pattern of the same load in the horizontal plane is shown. In c, a 2.5 cm in diameter and 4 mm deep patch of industrial grade epoxy adhesive is shown, after it was cured using the transistorized generator and the coaxial applicator. A ferrite isolator was used to protect the generator from severe mismatches, therefore, 16 W were available to the load. With state-of-the-art transistors the isolator may not be required since, as indicated in section 1, many of them can take an infinite VSWR. A two stub tuner was also used to obtain maximum transfer of power to the epoxy. Curing times were as follows:

Room temperature: 2 to 2.5 h.

With 16 W of microwave power and the coaxial applicator: 45 s.

This method of curing is very efficient since the power can be concentrated in the adhesive. It is also a very fast one as the results show. A blob of epoxy on an aluminum sheet was also cured with this method. Curing time was 60 s and adhesion of the epoxy to the aluminum was very good. Chips

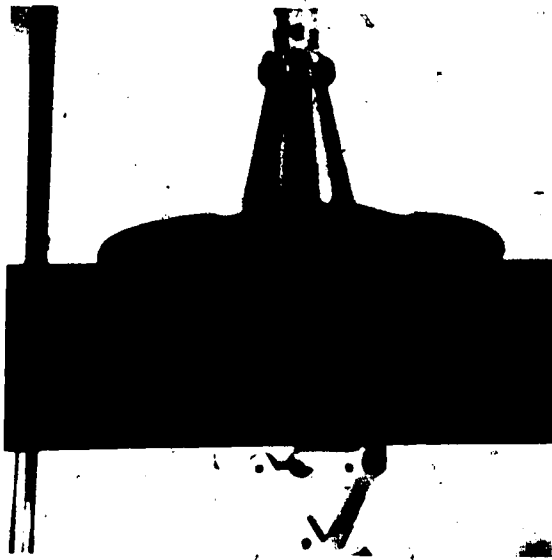

(a)

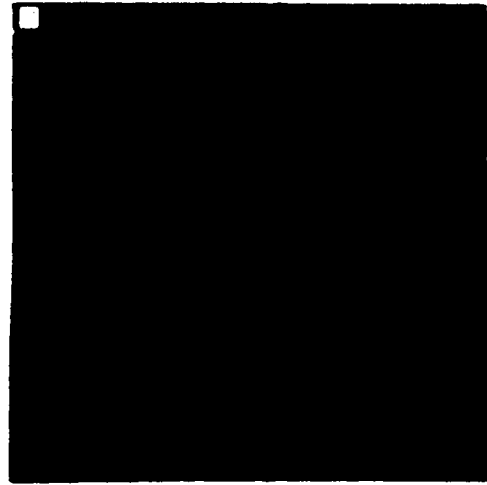

(b)

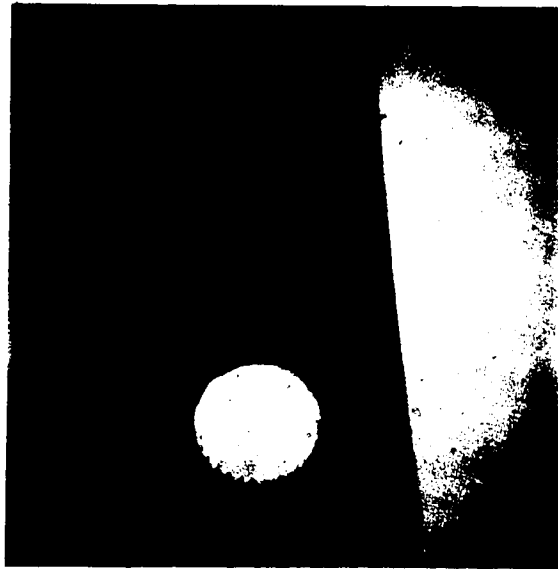

(c)

FIGURE A1.1 Epoxy patch cured with a 16 W transistorized microwave generator and a coaxial applicator.

of epoxy could only be broken out with a chisel and hammer.

Transistorized microwave power generators for use in microwave ovens or other high power applications, are not likely to be cost competitive for many years. For applications requiring less than 100 W and features like small size and safety of operation, transistorized microwave power generators offer the best solution.

4.- Design of a Transistorized ISM Microwave Power Source

The basic specifications were:

$$P \text{ (CW)} = 10 \text{ to } 20 \text{ W}$$

$$f \geq 915 \pm 19 \text{ MHz}$$

In view of the power transistors available at this frequency, there are three arrangements which can meet the specifications. Figure A1.2 shows a block diagram of these three schemes.

In (a), the output power is supplied directly by a single transistor connected as an oscillator. Although its simplicity is an attractive feature, it has two

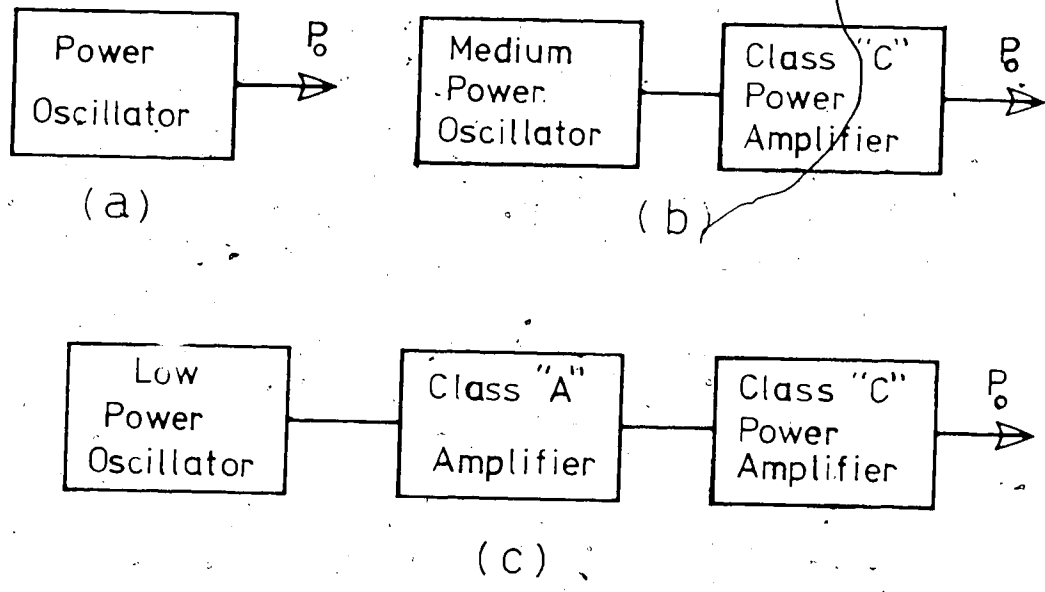

FIGURE A1.2 Three schemes that can meet the power source specifications.

disadvantages which make it undesirable for the intended application. The first is that a transistor operated as an oscillator is 10 to 15 % less efficient than the same transistor operated as a class C amplifier (80). The second is the strong load dependence of the oscillator frequency.

Scheme (b) can be regarded as a compromise between (a) and (c). The overall efficiency can be higher than that for the oscillator alone and the amplifier stage provides adequate isolation between the oscillator and the load. There is, however, one problem with this scheme. Due to the variation of the input impedance with input power in a class C amplifier and, because of the dependence of the oscillator frequency on this impedance, it is normally difficult for the oscillator to start. Nevertheless, this can be overcome by proper selection of the frequency characteristic of the oscillator output impedance and the amplifier input impedance.

Scheme (c) is the most elaborate. It comprises three transistors and the corresponding circuitry. Isolation of the oscillator is excellent and there is no starting problem. However, the overall efficiency is lower than that of the other two because of the inclusion of the class A amplifier stage.

In view of the above discussion scheme (b) was selected.

4.1 Class C Amplifier Design

The transistor selected for this stage was an MSC 4020, whose principal characteristics are (80):

$$V_{CC} = 28 \text{ V}$$

$$P_{\text{max}} (\text{CW}) = 20 \text{ W @ } 1 \text{ GHz, Case Temp., } 25^{\circ}\text{C}$$

$$\text{Power Gain} = 7.8 \text{ dB @ } 1 \text{ GHz, Case Temp., } 25^{\circ}\text{C}$$

$$\text{Coll. Eff.} = 50 \%$$

The design of a class C amplifier basically amounts to the design of an input and an output network. At each end the purpose of the network is to match the impedance of the transistor to that selected for the amplifier, in this case, 50Ω .

The main difficulty in the design of these networks arises from the very low values of the input and output impedance of microwave power transistors. Typical values, for saturated output power, are $(1 + j4)\Omega$ and $(5 + j2)\Omega$ respectively. Fortunately the design is somewhat simplified, in this case, because of the narrow bandwidth requirements.

A common base configuration was chosen because of its inherently higher stability, gain and efficiency at frequencies close to or higher than f_T (81).

Figure A1.3 shows the final circuit of the amplifier. The 0.3Ω resistor reduces the conduction angle to the point where maximum efficiency is obtained and its value was determined experimentally.

The amplifier was built using microstrip techniques because of their superiority over other methods and because they offer good reproducibility (82).

The characteristic impedance of a microstrip line can be calculated from graphs (83) or by the more accurate expression (84),

$$Z_0 = \frac{377 h}{\sqrt{\epsilon_r} W \left[1 + 1.735 \epsilon_r^{-0.0724} \left(\frac{W}{h} \right)^{-0.856} \right]}$$

where, h : spacing between the strip line and the ground plane.

W : width of the strip line.

ϵ_r : relative dielectric constant of the substrate.

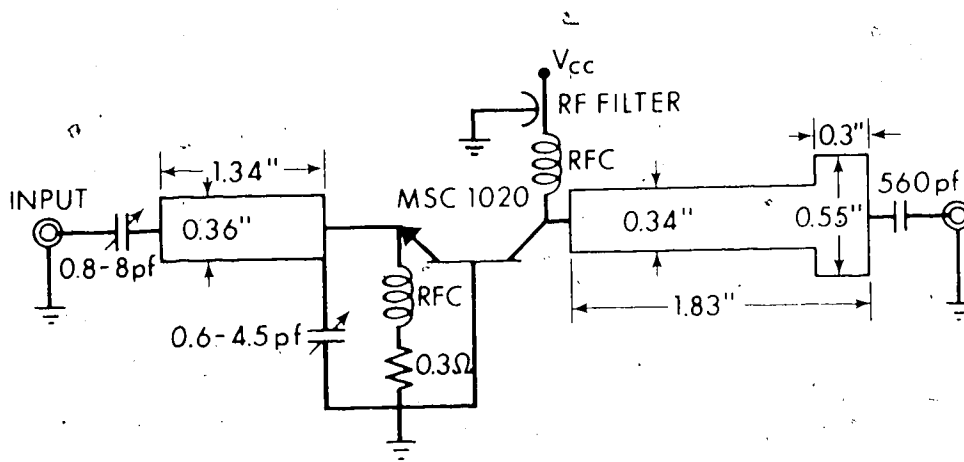

ϵ_r of microstrip substrate = 2.6

FIGURE A1.3 Amplifier schematic circuit.

The wavelength in the microstrip line is given by,

$$\lambda_M = \frac{\lambda_o}{\sqrt{\epsilon_r}}$$

where, λ_o : free space wavelength.

The amplifier was mounted directly on an extruded aluminum heatsink to reduce the operating temperature of the transistor (85) and the measured characteristics of the amplifier were:

$P_{max}(CW) = 18 \text{ W}$

Power gain = 7.2 dB

Efficiency = 47 %

4.2 Medium Power Oscillator Design

With a measured gain of 7.2 dB, 3 W were required to drive the amplifier to full output. The MSC 80069 was selected as a suitable transistor for this purpose. Its principal characteristics are:

$V_{CC} = 28 \text{ V}$

$P(Osc.) (CW) = 3 \text{ to } 4 \text{ W @ } 1 \text{ GHz, Case Temp. } 25^\circ\text{C.}$

Osc. Eff. 45 W

The design of transistorized microwave oscillators consists in the determination of a network that matches the output impedance of the transistor to that chosen for the oscillator (50Ω in this case), a bias network and a feedback network.

The design of the matching network follows the same techniques used in the amplifier, i.e., microstrip transmission line sections and subminiature trimming capacitors.

The biasing network is such that before oscillations start the transistor is biased in class A. As oscillations build up the bias conditions shift to class C to obtain high efficiency in the steady state.

The common base configuration was chosen for the same reasons given before. In this configuration the feedback path is normally provided by the emitter-collector capacitance of the transistor. Figure A1.4 shows the final circuit of the oscillator.

The oscillator was mounted on an extruded aluminum heatsink and the measured characteristics were:

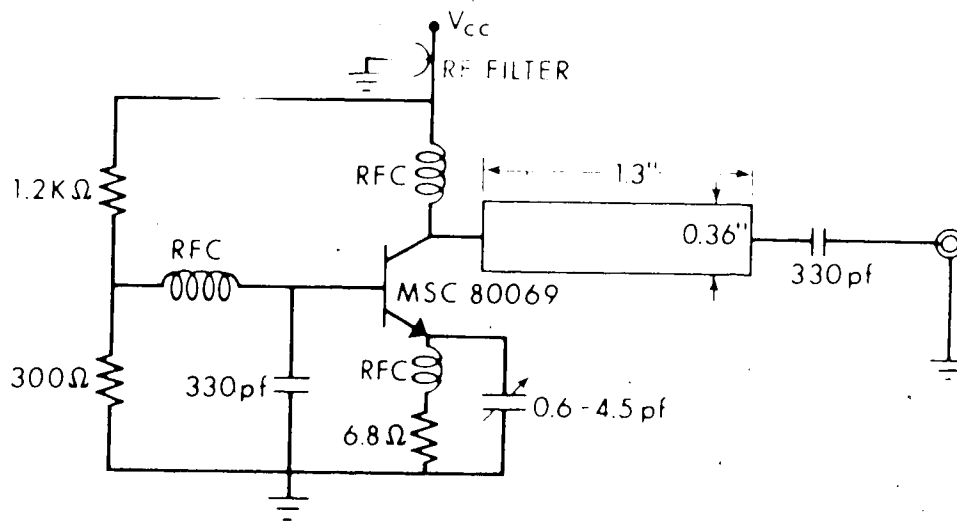

ϵ_r of microstrip substrate = 2.6

FIGURE A1.4 Oscillator schematic circuit.

$$P \text{ (CW)} = 3.2 \text{ W}$$

$$\text{Eff.} = 35 \%$$

$$\text{Freq. Range} \leq 915 \pm 25 \text{ MHz}$$

The circuits shown in Figures A1.3 and A1.4 are the circuits tried at after considerable experimentation to solve the starting problem. The measured characteristics of the complete unit were:

$$P \text{ (CW)} = 18 \text{ W}$$

$$\text{Efficiency} = 40 \%$$

$$\text{Frequency Range} = 915 \pm 22 \text{ MHz}$$

Frequency drift from cold to operating temperature < 3 MHz.

Harmonics are 20 dB or more below fundamental.

APPENDIX II

THEORY OF OPERATION OF ELECTRONIC TUNER

1.- Peak Detector

The upper part of the circuit in Figure A2.1 comprises a noninverting amplifier and a positive peak detector. The amplifier not only amplifies the signal from the detector diode, which in this case is negative, but also adds to it a fixed positive voltage. The detector diode should be operated in its square law region and zero output means zero reflected power, therefore, after the amplifier this condition appears as a positive voltage maximum.

The peak detector is a circuit whose output tracks the input signal until the input reaches a maximum value and then automatically holds that peak value. Therefore, in a given period of time, the last change in the output voltage of the peak detector corresponds to the largest input voltage peak as shown in Figure A2.2.

This voltage from the peak detector is differentiated. Therefore, the output from the differentiator becomes zero everytime the input to the peak detector has a maximum.

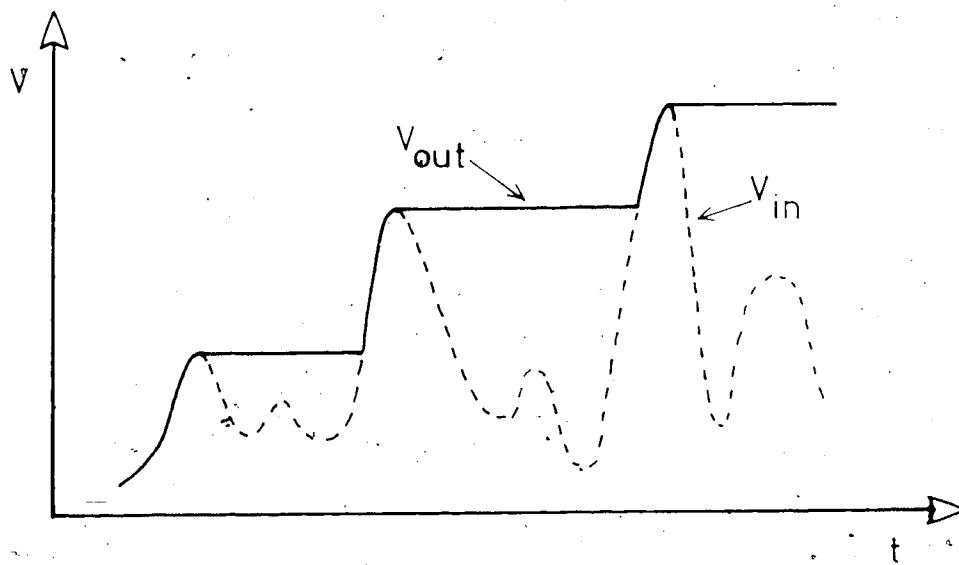

FIGURE A2.2 Output voltage from a positive peak detector.

Pulses are obtained for this condition by a Schmitt-Trigger circuit. A few other stages are used to properly condition these pulses to conform to the requirements of the Memory and D/A circuitry.

Resetting the peak detector at the beginning of the sweeping mode requires the following steps: opening of the input to the peak detector, discharging the holding capacitor (.1uf) and eliminating a pulse that accompanies the resetting process. Once the reset pulse from the Memory and D/A has been received, the resetting process is controlled by the 4047 Monostables and the 4071 Gate.

The first two steps mentioned above are executed by properly biasing the 2N5460 FET and the 2N3904 transistor respectively. The elimination of the initial pulse is achieved by temporarily inhibiting the output to the Memory and D/A.

In short, the circuit in Figure A2.1 generates negative pulses, during the sweeping mode, everytime the output of the detector diode goes through a maximum (minimum reflected power). The last pulse generated corresponds to the largest maximum.

2.- Memory and D/A

Referring to Figure A2.3, the clock is a free running multivibrator. The 4020 Counter and the 4072 Dual OR Gate determine the length of the sweep mode and the hold mode, in this case, 100 ms and 5 s respectively.

The 4000 Dual NOR Gate controls the storing of the state of the D/A in the memory everytime a pulse is received from the Peak Detector during the sweep mode and, the reading from the memory at the beginning of the hold mode. The 4029 is a Presettable UP/DOWN Counter provided with jam inputs. The two upper ones and the two lower ones are connected to obtain two 8 bit counters respectively.

The upper counter counts pulses from the clock and its binary output is fed to the 4016 Analog Gate. The output of these gates are added with the appropriate weighting factor in a 741 Operational Amplifier. The output to the modulation input of the VTM power supply is a discontinuous voltage ramp of 10 V maximum and steps of 39 mV. When the modulation gain in the VTM power supply is adjusted so that a change from 0 to 10 V causes the VTM to change 100 MHz, each frequency step amounts to 390 kHz.

The output from the upper counter is also connected to

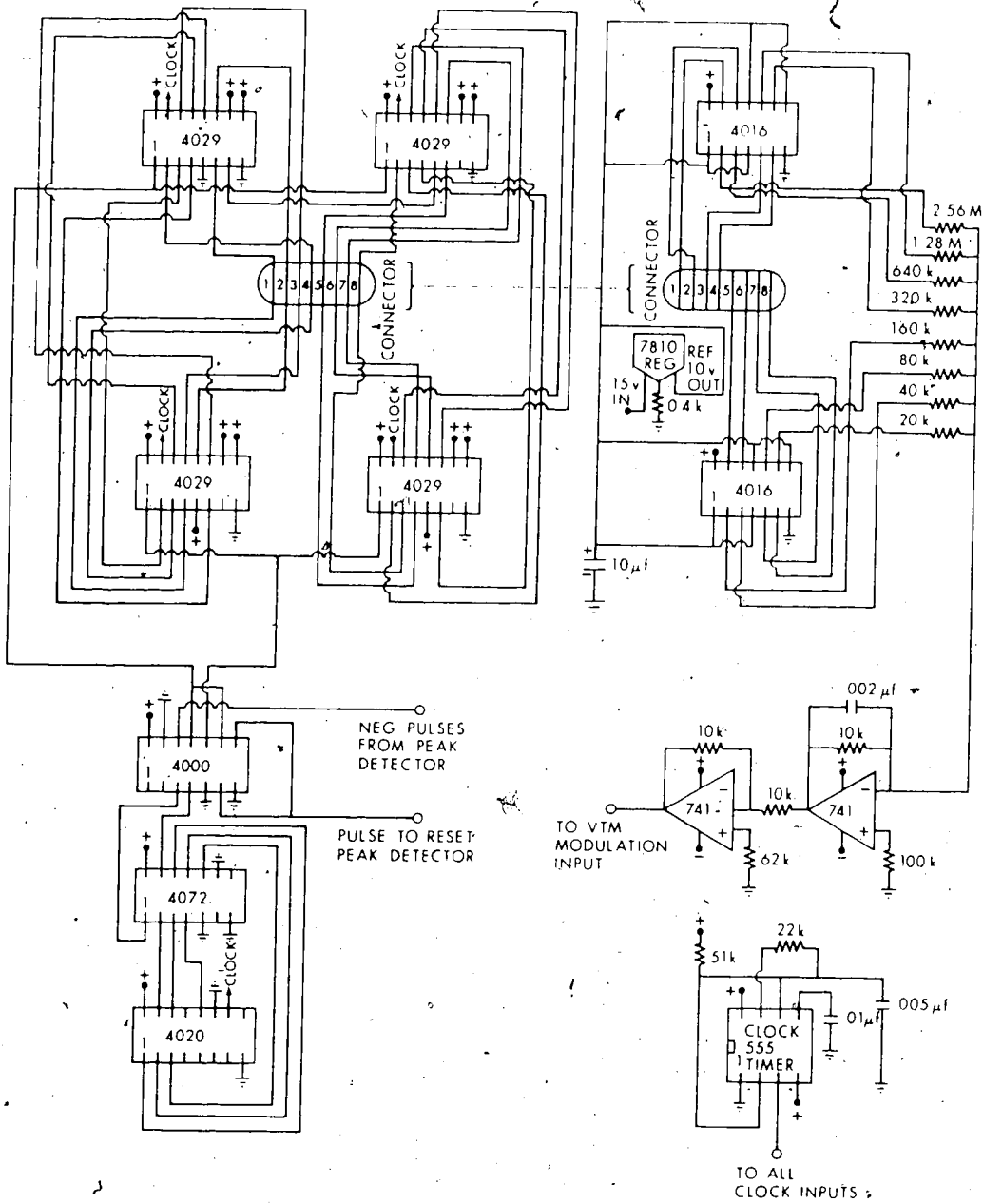

FIGURE A2.3 Memory and D/A schematic circuit.

the jam input of the lower counter which acts as a memory. The output from the memory is connected to the jam input of the upper counter.

During the sweep mode the upper counter counts pulses from the clock and with the rest of the D/A circuitry generates the modulating ramp. Everytime there is a pulse from the Peak Detector the binary output of this counter (state of the ramp) is jammed into the memory. At the end of the sweep mode the last binary number stored (corresponding to the frequency of minimum reflected power) is jammed into the upper counter, thereby setting the ramp to the voltage level that determines the frequency of minimum reflected power.

During the hold mode the upper counter is prevented from counting pulses from the clock. At the end of this mode the entire process is repeated.

APPENDIX IIITHEORY OF OPERATION OF THE DISCRETE FREQUENCY MODULATOR

Referring to Figure A3.1, two of the NOR gates in the 4001 Quad NOR Gate are connected together to form a free running multivibrator .

The two flip-flops in the 4027 Dual J-K Flip-Flop are clocked by the multivibrator and are connected in such a way as to generate pulses of a length equal to the period of the multivibrator signal. These pulses appear sequentially at points A, B and C and are added in a 741 Operational Amplifier with amplitudes set independently by the corresponding potentiometers.

The last operational amplifier is used as an inverter to obtain pulses of positive polarity. The maximum amplitude of these pulses was set at 10 V.

The circuit can easily be expanded to generate any number of sequential pulses all with independently adjustable amplitudes.



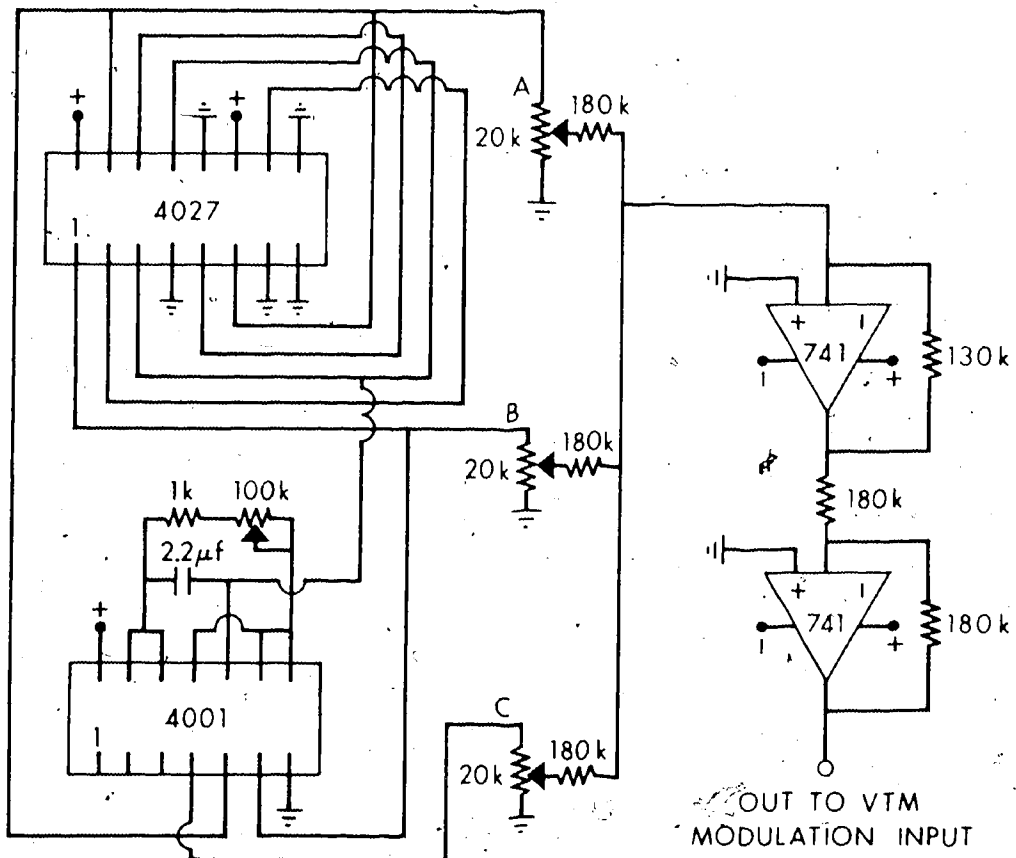

FIGURE A3.1 Discrete Frequency Modulator schematic circuit.

APPENDIX IVCOMPUTER PROGRAM TO OPTIMIZE CAVITY DIMENSIONS

Given target dimensions A, B, D for a cavity, this program will vary two dimensions (P and D) over a given range and in steps of a specified size.

For each set of dimensions, the modes with resonant frequency within the specified bandwidth around the central frequency are calculated and stored. For cubical cavities each set of L, M and N which is a solution, is taken as one mode and the sixfold degeneracy due to symmetry is not considered.

The program then orders the sets of dimensions from the one that yielded the highest number of modes to the one with the lowest number of modes. The form and number of the solutions are printed as specified.

The input data given by the user is the following:

- 1.- Central frequency, F: Up to 9999.9 MHz.
- 2.- Bandwidth above and below F, DF: Up to 99.9 MHz.
- 3.- Target dimensions, A, B, D: Up to 99.9 cm.
- 4.- Dimension range above and below B and D, DB and DD:

Up to 99.9 cm.

5.- Step size, STEP: Up to 99.9 cm.

6.- A number somewhat larger than the largest expected L, M or N, J: Up to 99.

7.- Number of solutions wanted, NMAX: Up to 99.

8.- Form of output, FORM: FORM=0, only the dimensions and number of modes are printed. FORM=1, the dimensions, number of modes and the modes (sets of L, M and N, and the corresponding resonant frequencies) are printed.

The data should be entered in the following format:

xxxx.xbxx.xbxx.xbxx.xbxx.xbxx.xbxx.xbxx.xbxxxbxxbx where b means a blank.

The compiler used in this program is the FORTRAN IV, version G. After the program listing an example is given with the two forms of output.

```

C   PROGRAM TO OPTIMIZE THE DIMENSIONS OF CAVITY
C   THE MAXIMUM NUMBER OF MODES
REAL BN(100),DN(100)
INTEGER*2 NMD(100),FORM,P,T,BIG
READ 200,F,DF,A,B,D,DB,DD,STEP,J,NMAY,FORM
C   CALCULATE NO. OF DIMENSION INCREMENTS
NB=2*(DB/STEP)+1.5
ND=2*(DD/STEP)+1.5
C   ESTABLISH LOWER LIMIT OF DIMENSIONS
BL=B-DB
DL=D-DD
I=0
C   INCREMENT DIMENSIONS B AND D. A,RS(2),DS(2) ARE THE
C   FIRST SET OF DIMENSIONS
DO 151 KB=1,NB
B=(KB-1)*STEP+BL
DO 151 KD=1,ND
D=(KD-1)*STEP+DL
I=I+1
BN(I)=B
DN(I)=D
MD=0
DO 150 LC=1,J
DO 150 MC=1,J
DO 150 NC=1,J
L=LC-1
M=MC-1
N=NC-1
C   CHECK IF CAVITY IS CUBICAL
IF (A-B) 90,60,90
60  IF (B-D) 90,70,90
C   REMOVE REPEATED SETS FOR CUBICAL CAVITY
70  IF (N-M) 150,80,80
80  IF (M-L) 150,90,90
C   ELIMINATE POSSIBILITY OF DOUBLE ZEROS
90  IF (L) 91,91,92
91  IF (M*N) 150,150,100
92  IF (M+N) 150,150,100
C   FIND A SOLUTION
100  FREQ=15000*SQRT((L/A)**2+(M/BN(I))**2+(N/DN(I))**2)
IF (ABS(F-FREQ-DF) 110,110,150
110  MD=MD+1
150  CONTINUE
NMD(I) = MD
151  CONTINUE
C   ARRANGE NOS. OF MODES IN ASCENDING ORDER
NMD(I)=MD
K=I
160  BIG=0
DO 170 MD=1,K
IF (BIG-NMD(MD)) 165,165,170

```



```

165  BIG=NMD(MD)
      T=MD
170  CONTINUE
      P=NMD(K)
      Q=BN(K)
      R=DN(K)
      NMD(K)=NMD(T)
      BN(K)=BN(T)
      DN(K)=DN(T)
      NMD(T)=P
      BN(T)=Q
      DN(T)=R
      K=K-1
      IF (K-2) 180, 160, 160
180  CONTINUE
C    CALCULATE AND PRINT MODES IN DESCENDING ORDER
      PRINT 300
      IF (FORM.EQ.1) PRINT 301
      MAX=MIN0(NMAX,I-1)
      DO 192 P=1,MAX
      K=I-P+1
      PRINT 302,A,BN(K),DN(K),NMD(K)
      IF (FORM) 192,192,171
171  DO 190 LC=1,J
      DO 190 MC=1,J
      DO 190 NC=1,J
      L=LC-1
      M=MC-1
      N=NC-1
      IF (A-B) 184,181,184
181  IF (B-D) 184,182,184
182  IF (N-M) 190,183,183
183  IF (N-L) 190,184,184
184  IF (L) 185,185,186
185  IF (M*N) 190,190,187
186  IF (M+N) 190,190,187
187  FREQ=15000*SQRT((L/A)**2+(M/BN(K))**2+(N/DN(K))**2)
      IF (ABS(F-FREQ-DF) 191,191,190
191  PRINT 303,L,M,N,FREQ
190  CONTINUE
192  CONTINUE
200  FORMAT (F6.1,7(1X,F4.1),2(1X,I2),1X,I1)
300  FORMAT ('1',3X,'DIMENSIONS (CM)          NO. CF MODES')
301  FORMAT ('+',40X,'MODE          FREQ. (MHZ)')
302  FORMAT ('-',3(F6.2,2X),5X,I2)
303  FORMAT ('+',37X,'( ',I2,', ',I2,', ',I2,', ', ',5X,F6.1/' ')
      STOP
      END

```



DATA

2450.0 15.0 40.0 49.0 39.0 0.2 0.2 0.1 8 1 0

DIMENSIONS (CM) NO. OF MODES

40.00 49.00 38.90 14
40.00 48.90 39.10 13

DATA

2450.0 15.0 40.0 49.0 39.0 0.2 0.2 0.1 8 1 1

DIMENSIONS (CM) NO. OF MODES MODF FREQ. (MHZ)

DIMENSIONS (CM)	NO. OF MODES	MODF	FREQ. (MHZ)
40.00 49.00 38.90	14	(0, 5, 5)	2461.7
		(0, 7, 3)	2435.2
		(1, 7, 3)	2463.9
		(2, 1, 6)	2451.3
		(3, 5, 4)	2446.9
		(3, 6, 3)	2444.9
		(3, 7, 1)	2450.7
		(4, 0, 5)	2442.8
		(4, 1, 5)	2461.9
		(4, 5, 3)	2435.4
		(5, 1, 4)	2447.1
		(5, 5, 1)	2450.9
		(6, 2, 2)	2456.0
		(6, 3, 1)	2460.6